

UC Berkeley

Earlier Faculty Research

Title

Buying Time at the Curb

Permalink

<https://escholarship.org/uc/item/2wz7401k>

Author

Shoup, Donald C

Publication Date

2003-03-01

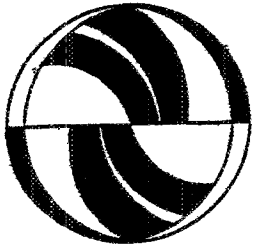

Buying Time at the Curb

Donald C. Shoup

UCTC
No 615

**The University of California
Transportation Center**
University of California
Berkeley, CA 94720

**The University of California
Transportation Center**

The University of California Transportation Center (UCTC) is one of ten regional units mandated by Congress and established in Fall 1988 to support research, education, and training in surface transportation. The UC Center serves federal Region IX and is supported by matching grants from the U.S. Department of Transportation, the California Department of Transportation (Caltrans), and the University.

Based on the Berkeley Campus, UCTC draws upon existing capabilities and resources of the Institutes of Transportation Studies at Berkeley, Davis, Irvine, and Los Angeles, the Institute of Urban and Regional Development at Berkeley, and several academic departments at the Berkeley, Davis, Irvine, and Los Angeles campuses. Faculty and students on other University of California campuses may participate in

Center activities. Researchers at other universities within the region also have opportunities to collaborate with UC faculty on selected studies.

UCTC's educational and research programs are focused on strategic planning for improving metropolitan accessibility, with emphasis on the special conditions in Region IX. Particular attention is directed to strategies for using transportation as an instrument of economic development, while also accommodating to the region's persistent expansion and while maintaining and enhancing the quality of life there.

The Center distributes reports on its research in working papers, monographs, and in reprints of published articles. It also publishes *Access*, a magazine presenting summaries of selected studies. For a list of publications in print, write to the address below.

DISCLAIMER

The contents of this report reflect the views of the authors, who are responsible for the facts and the accuracy of the information presented herein. This document is disseminated under the sponsorship of the Department of Transportation, University Transportation Centers Program, in the interest of information exchange. The U.S. Government assumes no liability for the contents or use thereof.



University of California
Transportation Center

108 Naval Architecture Building
Berkeley, California 94720
Tel. 510/643-7378
FAX. 510/643-5456

The contents of this report reflect the views of the author who is responsible for the facts and accuracy of the data presented herein. The contents do not necessarily reflect the official views or policies of the State of California or the U.S. Department of Transportation. This report does not constitute a standard, specification, or regulation.

BUYING TIME AT THE CURB

Donald C. Shoup
Chair, Department of Urban Planning
Director, Institute of Transportation Studies
University of California, Los Angeles
Los Angeles, CA 90095-1656
shoup@ucla.edu

January 12, 2002

forthcoming in

*The Half-Life of Policy Rationales:
How New Technology Affects Old Policy Issues*
Edited by Fred E. Foldvary and Daniel B. Klein
New York: NYU Press

BUYING TIME AT THE CURB

Donald C. Shoup

ANOTHER PLANNING DISASTER	2
CURB PARKING AS A COMMONS PROBLEM	2
THE IMMACULATE CONCEPTION OF PARKING DEMAND	3
PLANNING WITHOUT PRICES	3
LET PRICES DO THE PLANNING	5
THE FIRST PARKING METER	5
THE TECHNOLOGY OF CHARGING FOR CURB PARKING	6
Multispace Meters	8
Personal In-Vehicle Meters	10
Cashless Payment Systems	12
HONK IF YOU HATE PAID PARKING	12
PARKING BENEFIT DISTRICTS	13
BUSINESS PARKING BENEFIT DISTRICTS	14
A PRECEDENT: BUSINESS IMPROVEMENT DISTRICTS	15
CREATING A MARKET FOR PARKING IN RESIDENTIAL NEIGHBORHOODS	17
RESIDENTIAL PARKING BENEFIT DISTRICTS	18
DO IT IN MY FRONT YARD	20
CONCLUSION: WE SHALL OVERCOME	21
ENDNOTES	23
REFERENCES	26

BUYING TIME AT THE CURB

*I'll tell you how to solve Los Angeles' traffic problem
Just take all the cars off the road that aren't paid for*
WILL ROGERS

American children first learn about free parking when they play *Monopoly*. Players move around the board and buy houses, build hotels, or go to jail after throwing the dice—but occasionally they land on “Free Parking.” When children grow up and get real cars, their odds of landing on free parking increase dramatically because drivers park free for 99 percent of all automobile trips in the United States.¹

Although drivers park free for 99 percent of all their trips, you probably feel that you pay for parking on more than 1 percent of *your* automobile trips, and perhaps you do. Many of us undoubtedly pay for parking more frequently than others do. Americans make 230 billion vehicle trips a year, so drivers pay for parking 2.3 billion times a year (1 percent of 230 billion), but they also park free 228 billion times a year.²

If drivers don't pay for parking, who does? Initially, developers pay for it when they provide all the parking spaces required by zoning ordinances. The cost of land and capital devoted to required parking raises the cost of all development, and this cost translates into higher prices for everything else, so everyone pays for parking indirectly. Residents pay for parking through higher prices for housing. Consumers pay for parking through higher prices for goods and services. Employers pay for parking through higher office rents. Only in our role as motorists do we *not* pay for parking because motorists park free for most trips. *Everyone but the motorist pays for parking.*

Minimum parking requirements collectivize the cost of parking. Where the cost of parking a car is included in higher prices for other goods and services, people cannot pay less for parking by using less of it. Bundling the cost of parking into higher prices *for* everything else distorts consumer choices toward cars and away *from* everything else.³

I will argue that free parking is the unstudied link between transportation and land use, that urban planners make serious mistakes in dealing with parking, and that these mistakes gravely distort the markets for both transportation and land. I will then describe several new technologies of charging for curb parking spaces. Finally, I will propose a modest change in planning practice that has high benefits and low costs, that is fair, and that the new technology makes feasible.

ANOTHER PLANNING DISASTER

Urban planners typically set off-street parking requirements high enough to satisfy the peak demand for free parking. These parking requirements increase the supply and reduce the price—but not the cost—of parking. Parking requirements bundle the cost of parking spaces into the cost of development, and thereby increase the prices of all the goods and services sold at the sites that offer free parking. Minimum parking requirements subsidize cars, raise housing costs, reduce urban density, and seriously distort transportation and land use.

Off-street parking requirements in zoning ordinances have severed the link between the cost of providing parking and the price that drivers pay for it. The cost of providing parking has ceased to influence most decisions about whether to own or use a car. Motorists own and use cars as if parking costs nothing because they pay nothing, and the added driving increases traffic congestion. When citizens object to congestion, planners restrict new development to reduce traffic. Minimum parking requirements then force development to subsidize cars, and planners must limit the density of development (and of people) to limit the density of cars. Free parking has become the arbiter of urban form, and cars have replaced people and buildings as zoning's real density concern. Form no longer follows function, fashion, or even finance. Instead, form follows parking requirements.

CURB PARKING AS A COMMONS PROBLEM

Cities adopted minimum parking requirements because citizens and politicians understand that they solve a real problem—the commons problem. If curbside parking is free, and if buildings do not provide enough off-street parking to serve their own uses, curbside parking will quickly become congested. In his famous essay "The Tragedy of the Commons," Garrett Hardin used curbside parking to illustrate the commons problem:

During the Christmas shopping season the parking meters downtown were covered with plastic bags that bore tags reading: "Do not open until after Christmas. Free parking courtesy of the mayor and city council." In other words, facing the prospect of an increased demand for already scarce space, the city fathers reinstated the system of the commons.⁴

Voters who see the gift-wrapped parking meters may thank their mayor and city council, but free parking at the time of peak demand makes curbside spaces even harder to find. Drivers who circle the block searching for a free space add to traffic congestion and air pollution, and when they do find

a free space they park longer than if the meters had not been gift wrapped. Drivers get a commons problem for Christmas.

Planners solve the parking commons problem by requiring developers to increase the parking supply by as much as they increase parking demand. A new building may increase the demand for parking, but if the building provides enough parking spaces to meet this increased demand, competition for the existing parking supply does not increase.

A big problem with this solution is the way planners estimate demand. Planners do not estimate the demand for parking as a function of price. Instead, planners make the unstated (perhaps even unconscious) simplifying assumption that all parking is free. That is, planners estimate the demand for *free* parking and then require enough parking spaces to meet this demand. In effect, *urban planners treat free parking as an entitlement, and they consider the resulting demand for free parking to be a "need" that must be met*

THE IMMACULATE CONCEPTION OF PARKING DEMAND

The planning "vision" behind minimum parking requirements is a world with ample free parking. Cities legislate this vision into reality for every new building, no matter how much the required parking spaces cost. Planners set minimum parking requirements to satisfy the peak demand for free parking, and the immense parking supply creates a surplus of parking spaces most of the time. This excess supply drives the market price of parking to zero, and drivers park free for 99 percent of all trips. Free parking inflates parking demand, and this inflated demand is then used to set the minimum parking requirements. Because of this circular reasoning, free parking dictates the design of urban development. Minimum parking requirements that meet the peak demand for free parking are, in reality, free parking requirements.

Urban planners may believe that they are simply requiring enough parking spaces to satisfy demand, but this demand was not immaculately conceived. Others may believe that the demand for cars is simply the result of consumer preferences being expressed in a free market. Instead, planners and the market coupled long ago to conceive today's swollen demand for cars and parking

PLANNING WITHOUT PRICES

Urban planners diagnose the parking problem in a way that makes it extremely expensive to solve. Thinking that there is a parking shortage, planners require developers to supply at least

enough parking spaces to satisfy the peak demand for free parking. In one of the few attempts to explain how planners set parking requirements, Robert Weant and Herbert Levinson say,

Most local governments, through their zoning ordinances, have a parking supply policy that requires land uses to provide sufficient off-street parking space to allow easy, convenient access to activities while maintaining free traffic flow. The objective is to provide enough parking space to accommodate recurrent peak-parking demands. . . . parking demand is defined as the accumulation of vehicles parked at a given time as the result of activity at a given site.⁵

In effect, Weant and Levinson say that planners define the number of cars counted at peak periods as parking demand (with no reference to the price of parking), and then require developers to supply at least this many parking spaces (with no reference to the cost of parking).

Parking must be free at most of the land uses where planners measure the peak-parking demands because parking is free for most automobile trips in the United States.⁶ When they set parking requirements, planners thus do not define demand and supply the way economists define these terms. For example, economists do not define the demand for food as the recurring peak quantity of food consumed at all-you-can-eat-for-free buffets where diners eat until the last bite has zero utility. Economists do not say that this recurring peak quantity of food eaten must be supplied whatever the cost. Yet planners *do* define the demand for parking as the recurring peak number of parking spaces occupied when parking is free. Planners *do* require this number of parking spaces to be supplied whatever the cost. Planning for parking is planning without prices.

Parking is an essential part of the transportation system, and the parking supply produces enormous benefits. Nevertheless, these enormous benefits do not imply that we need more parking, or that parking should be free. Similarly, the food supply produces enormous benefits, but these enormous benefits do not imply that we need more food, or that food should be free. Many of us already eat too much, and free food would encourage us to eat even more. Nevertheless, some cities' zoning ordinances explicitly require *free* parking. For example, the zoning ordinance for Wilshire Boulevard in Los Angeles, which has the best public transit access in the city, requires.

For office and other commercial uses there shall be at least three parking spaces provided for each 1,000 square feet of gross floor area available at no charge to all patrons and employees of those uses.⁷

The only unusual aspect of this ordinance is that it mentions the price of parking. Free parking is the only reference to the price of parking that I have seen in any city's parking requirements

LET PRICES DO THE PLANNING

Most markets benefit so much from using prices to allocate resources that it's hard to imagine they could operate in any other way. Nevertheless, cities have tried to manage the parking market almost entirely without prices, and the result is a disaster. Planning without prices has worked poorly almost everywhere it has been tried, and parking is no exception.

As an alternative to setting time limits on curb parking, cities could charge the market price for curb parking. The market price for curb parking is the price that balances (1) a parking demand that varies and (2) a parking supply that is fixed. If cities charge flexible market prices to balance the varying demand with the fixed supply—prices high enough to keep a few curb parking spaces vacant on every block—drivers will always find a place to park near their destination

With prices to restrain the demand for curb parking, developers and businesses will be able to decide on their own how much off-street parking they want to provide. This arrangement—*charge market prices for curb parking and deregulate off-street parking*—will increase public revenue and reduce private costs. Instead of planning without prices, we can let prices do the planning.

Two major obstacles have prevented cities from charging market prices for curb parking. First, the technology of charging for curb parking was primitive until quite recently. Second, motorists don't want to pay for parking on the street or anywhere else. I will first describe how new technology has removed the first obstacle to charging for curb parking—the practical difficulty. I will then argue that a new distribution of curb parking revenue can remove the second obstacle—the political difficulty that drivers don't want to pay for parking.

THE FIRST PARKING METER

Carl Magee of Oklahoma City filed his patent application for a “coin controlled parking meter” on May 13, 1935, and the world's first parking meter was installed in Oklahoma City on July 16, 1935.⁸ From the user's point of view, most parking meters are still identical to the 1935 model: you put coins in the meter to buy a specific amount of time, and you risk getting a ticket if you don't return before your time runs out.

FIGURE 1

Parking meters ensure turnover of curb parking spaces, and their original purpose was simply to enforce the time limits for curb parking. The time limits on metered parking and the prohibition against feeding a meter to gain extra time show that the primary purpose of most parking meters is still to ensure turnover rather than to charge the market price for parking.⁹

FIGURE 2

Figure 3 shows Magee's drawing of his invention. The proposed parking meter looks more streamlined than today's models, but one could easily think that the sketch represents a present-day parking meter on any city street. Few technologies have advanced so little since 1935.

FIGURE 3

In his 1964 article on transaction costs, Harold Demsetz mentions the transactions costs of charging for parking as a reason to offer it free.

Our first example is zero-priced parking . . . It is true that the setting and collecting of appropriate shares of construction and exchange costs from each parker will reduce the number of parking spaces needed to allow ease and entry of exit. But while we have reduced the resources committed to constructing parking spaces, we have increased resources devoted to market exchange. We may end up by allocating more resources to the provision and control of parking than had we allowed free parking because of the resources needed to conduct transactions.¹⁰

Demsetz later comments, "The preceding discussion has taken as given the state of technical arts." The technology of charging for parking has changed greatly in recent years, and this change has undermined the case for free parking.

THE TECHNOLOGY OF CHARGING FOR CURB PARKING

Minimum parking requirements in zoning ordinances explain *why* the technology of charging for curb parking has stagnated. Because urban planners require enough off-street parking spaces to satisfy the peak demand for free parking at all new land uses, there is no need to charge for curb parking. By eliminating the need to charge for an important public service, urban planners have succeeded where nuclear physicists failed. Advocates once predicted that nuclear power plants were so efficient that they would soon make electricity "too cheap to meter." That prediction failed spectacularly, but parking *is* free for 99 percent of automobile trips. Most parking in America is, literally, too cheap to meter.

FIGURE 1

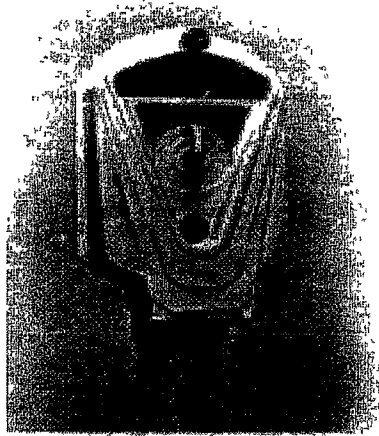

The First Parking Meter

FIGURE 2

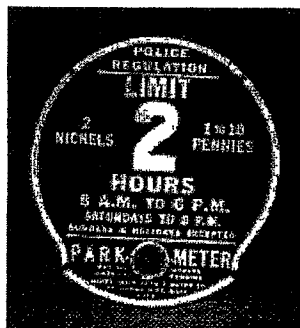

FIGURE 3
 PATENT FOR THE PARKING METER

May 24, 1938.

C. C. MAGEE

2,118,318

COIN CONTROLLED PARKING METER

Filed May 13, 1935

4 Sheets-Sheet 1

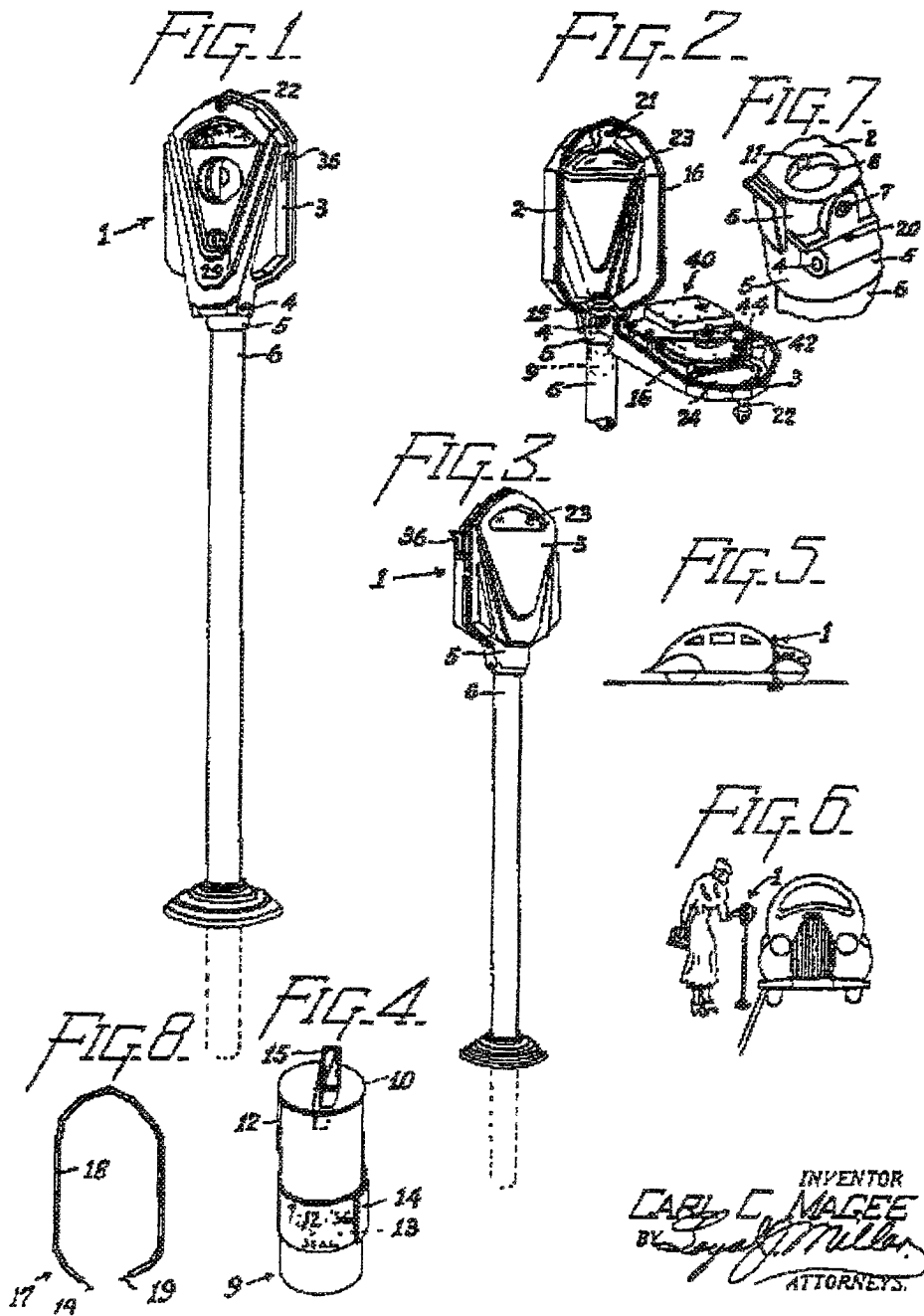

INVENTOR
 CARL C. MAGEE
 By *Raymond J. Miller*
 ATTORNEYS.

The parking meter was invented in the United States, but minimum parking requirements have inhibited subsequent technological change in this country. Cities rapidly added parking requirements to their zoning ordinances in the 1940s and 1950s, and parking meters are now used mainly in areas developed before cities required off-street parking. Most new ways to charge for curb parking have been invented in Europe because the scarcity of parking in many older European cities has created a demand for more sophisticated metering.

One severe defect of the traditional parking meter is that drivers must decide in advance how long they want to park. The drivers' subsequent concern about returning before the meter expires can create "meter anxiety." This handicap has until recently been assumed to be an inherent feature of paying for curb parking, but new technology allows drivers to pay for curb parking without deciding in advance how long they want to park. Buying time at the curb can now be as convenient as buying other goods and services.

Describing how one city—Aspen, Colorado—uses the new parking meter technology shows how any city can use it. Aspen is hardly a typical American city, but until recently it suffered from all the usual parking problems. With 5,000 residents and 25,000 visitors a day during the winter and summer seasons, curb parking is scarce. Until 1995, curb parking was free and restricted only by a 90-minute time limit. Time-limited free parking created predictable problems. As described by Aspen's Assistant City Manager, Randy Ready,

Most of the downtown parking spaces in Aspen were being occupied by locals and commuters working in downtown and moving their cars every ninety minutes to avoid parking tickets in what we affectionately called the "90 Minute Shuffle." Few if any spaces were available for shoppers, restaurant patrons, and guests. The result was a commercial core full of employees' parked cars and streets congested with angry guests' and shoppers' cars endlessly trolling for a parking space.¹¹

Aspen attempted to reduce its parking problem by building a 340-space underground municipal parking garage in 1991 but,

despite its convenient location and \$1.50 a day rate, only during special occasions did it ever fill. On most days the garage remained over half empty, while tremendous congestion and competition raged for free on-street parking a block away.¹²

After several years of preparation, in 1995 Aspen began to charge for curb parking in order to reduce traffic and parking congestion. Parking is now priced highest in the city center—\$1 an

hour in the commercial core and declining with distance from the core. Aspen also established Residential Parking Permit (RPP) districts in neighborhoods surrounding the commercial area, and it allows nonresidents to park in RPP districts for \$5 a day.

Aspen's success with paid parking stems, in part, from two new technologies it uses to charge for curb parking: (1) multispace meters placed on the street, and (2) personal in-vehicle meters issued to individual motorists.

Multispace Meters

Aspen places one "pay and display" multispace parking meter mid-block on each side of the street in the commercial area. After parking, drivers walk to the meter and pay for the length of time they wish to park. The meter delivers a receipt imprinted with the time of issue, fee paid, and date for which parking has been purchased; the driver then displays the ticket inside the car's windshield. One inexpensive and unobtrusive multispace pay-and-display meter usually controls 20 to 30 parking spaces. Aspen is one of only a few cities in the United States to use multispace parking meters, but many European cities use them for both curb and off-street parking

FIGURE 4

Aspen has found several important advantages in using multispace pay-and-display meters:

1. **Ease of payment.** Multispace meters accept coins, bills, tokens, charge cards, or smart cards. Drivers do not need to carry exact change to feed the meters.
2. **Flexible prices.** Multispace meters can charge different prices at different times of the day or different days of the week.
3. **Better revenue control.** Multispace meters provide excellent revenue control, and they reduce the manual labor involved in collecting, transferring, and counting coins.
4. **Better urban design.** One multispace meter replaces 20 to 30 individual post-mounted meters, and the pay-and-display procedure does not require striping the street to mark individual curb spaces. Multispace meters thus reduce street clutter, hardware, and signs.
5. **More parking spaces.** Because individual spaces are not marked on the street, more cars can typically park at the curb than when the permanent placement of individual meters requires every space to be long enough to accommodate full-sized cars.

FIGURE 4

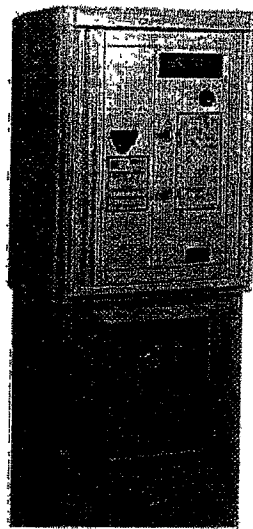

Pay-and-Display
Meter

6. **Economy.** One multispace meter costs less to purchase and maintain than the 20 to 30 individual meters that it replaces.
7. **Better data collection.** Electronic technology provides excellent records of parking occupancy rates on each block.

Aspen carried out an extensive education and public relations program when it introduced the new technology. It gave one free \$20 smart card to every Aspen resident to familiarize them with the new multispace meters, and it voided one parking ticket per license plate for violations of the new paid parking program. Parking control officers carried smart cards to offer an hour of free parking to drivers who were confused by the new meters.¹³ These public education and consumer relation efforts are often overlooked but can pay big dividends in the acceptance of new technology

Another form of multispace parking meter—pay-by-space—also works well for curbside parking. The city paints a number on the sidewalk beside each curbside space, and installs signs directing parkers to the pay-by-space meters. Berkeley, California installs one of these meters for every eight curbside spaces, and they are simple to use. John Van Horn (1999, 42-44) describes their operation

The driver parks his car, notes the space number and goes to the machine. He selects the space number and inserts the appropriate coins. The machine displays the amount of time purchased. Enforcement officers can easily see which spaces are in violation by observing small windows in the back of the machine. When a space is in violation, a red fluorescent dot appears. . . . On the face of the machine, in addition to the space numbers, is an “information” button that when pressed gives the parker additional information about the unit and whatever else the city wishes to place on the display. The city has also placed its toll-free number on the machines, but so far has received no complaint calls.¹⁴

FIGURE 5

Berkeley’s Assistant City Manager says “The feedback has been positive—as positive as you can get for a parking meter.”¹⁵ Beyond the previously mentioned advantages of the pay-and-display meters, these pay-by-space meters offer four additional advantages:

1. **Convenience.** Parkers who have entered the number of their space in the meter do not need to return to their vehicles, and they do not need to display a receipt on the dash.
2. **Grace time.** The meters can offer a “grace” period before displaying a violation.
3. **Networks.** All multispace meters in an area can be networked so that parkers can extend the time on their space by paying at the nearest meter without returning to their vehicles.

FIGURE 5

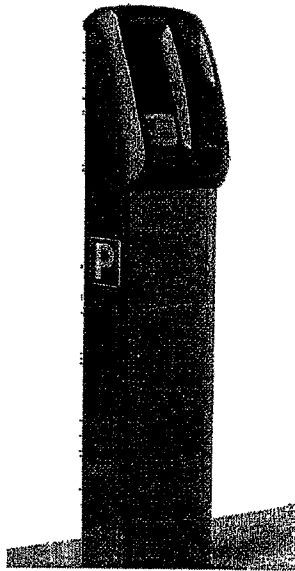

Pay-by-Space Meter

4. **No “meter anxiety.”** Parkers who pay by credit card or debit card can pay for more time than they expect to use, and they can reinsert their cards when they return to obtain a refund for the unused time.

Personal In-Vehicle Meters.

In addition to using multispace meters, Aspen issues personal in-vehicle parking meters. Describing these electronic meters in some detail will show the rapid advances in technology in recent years. Personal in-vehicle parking meters are similar in size and appearance to a small pocket calculator. Motorists use the in-vehicle meters in combination with a stored-value (smart) card to pay for curb parking on any block where there is a charge

FIGURE 6

The city demarcates the zones where curb parking is priced, assigns a number to each zone, and posts the price charged for parking in the zone. After parking, the driver keys in the parking zone’s number, inserts the smart card, switches the meter on, and hangs it inside the car’s windshield with its liquid crystal display (LCD) visible. The timer debits the prepaid account for the parking time elapsed until the driver returns and switches it off.¹⁶ Enforcement personnel can easily see whether a parked car’s meter is running because they can see the zone code flashing in the LCD window. Drivers can see the remaining prepaid value both at the beginning and the end of each use, and are thus constantly made aware of the cost of parking.

Europeans call the in-vehicle meter an “electronic purse” because of its convenience. Paying for parking with an in-vehicle meter is like paying for telephone calls with a debit card. Callers pay for telephone calls according to where they call, when they call, and how long they talk. Similarly, drivers pay for parking according to where they park, when they park, and how long they park.

Arlington, Virginia was the first local government in the United States to introduce the in-vehicle parking meters in 1989. Surveys have shown an overwhelming positive response from motorists who use the new meters.¹⁷ Cities that have adopted the in-vehicle meter system report the following advantages:

1. **No need for cash.** Drivers do not need coins, tokens, or exact change because the in-vehicle meters operate like debit cards.

FIGURE 6



In-Vehicle Parking Meter

2. **Accurate payments for parking.** Drivers pay for the exact parking time they use—no more, no less. Drivers do not pay for "leftover" meter time that they don't use.
3. **No "meter anxiety."** Drivers do not need to decide in advance how long they want to park and they do not need to return to their cars by a specific time, so they do not suffer from meter anxiety.
4. **Receipt for parking fees.** The electronic memory of the in-vehicle meter can provide a receipt for parking fees.
5. **Higher turnover.** In-vehicle meters encourage parking turnover because drivers pay for parking by the minute. Drivers will not use up time at the curb simply because they have paid for it.
6. **Mobility.** The same in-vehicle meter can be used in several cities
7. **Low cost.** The city does not need to buy and install conventional post-mounted meters or to pay for the manual collection, transfer, and counting of coins. The city collects parking revenue in advance, and in-vehicle meters provide excellent revenue control at low cost
8. **Flexible prices.** In-vehicle meters can charge different rates in different areas, at different times of the day, and for different parking durations.
9. **Revenue in advance.** The city collects the parking revenue in advance, and earns interest on the unused balances.
10. **Compatibility with conventional meters.** Drivers can use their in-vehicle meters to pay for parking at conventional post-mounted parking meters or multispace meters. Rather than pay for parking by putting coins in the conventional meter, drivers display their in-vehicle meters. Visitors who do not have in-vehicle meters can pay at the conventional meters.
11. **No theft or vandalism.** To deter theft each in-vehicle meter has a personal identification number (PIN) entered by the user, and the meter is useless without the PIN. In-vehicle meters also eliminate the risk of vandalism commonly directed against post-mounted meters
12. **Better urban design.** In-vehicle meters reduce the need for conventional parking meters on the sidewalk, and do not require painting stripes on the street to mark the curb spaces..
13. **Ease of enforcement.** Enforcement personnel can easily see whether a parked car's meter is running because they can see the zone code flashing in the LCD window

14. Fewer parking violations. If legal parking spaces are available, drivers with in-vehicle meters will usually pay for parking rather than to risk a ticket

These substantial advantages come at a very low cost. Aspen requires a one-time deposit of \$40 per in-vehicle meter. Users can prepay for as much parking time as they want, and they can add value to their meters' remaining balance whenever they like. In-vehicle parking meters are extremely popular with Aspen residents; the city sold 300 meters in the first three days, and has sold more than 5,000 since 1995 (in a city with 5,000 residents).¹⁸

Cashless Payment Systems

Although multi-space and in-vehicle parking meters are unfamiliar to most Americans, they are common in European cities, and the cost of converting European parking meters to the Euro currency is spurring newer forms of cashless payments for parking. For example, some cities in Holland and Sweden have introduced a system that relies on cellular telephones to pay for curb parking. A driver parks, dials the city's number for the parking payment system, and keys in both the license plate number and the number of the district where the car is parked. A transponder in the windshield shows enforcement officers that the car is registered for the payment system, and without stopping to inspect the car the officers can electronically interrogate the car's transponder to check that it is paying for parking. After returning to the car, the driver dials the same number to end the payment, so drivers pay only for the exact time parked, and the city sends bills to motorists periodically. In addition to the added convenience for drivers, the city benefits from reduced vandalism, lower collection costs, and lower maintenance costs.¹⁹

HONK IF YOU HATE PAID PARKING

Prices for parking in Aspen did not come without protest. Opponents organized a "Honk if You Hate Paid Parking" campaign at the end of 1994, just before Aspen's pricing program began.

Precisely at noon on the Friday before the New Year, employees of the downtown shops and restaurants (and more than a few from City Hall) poured out of their workplaces, walked to their cars parked right in front a few steps away, and proceeded to honk their horns for half an hour in protest of the parking regulations that would soon go into effect. . . . The local chapter of the Sierra Club added flavor with several of their members parading in gas masks, including one dressed as a clown riding a unicycle and carrying a sign that read, "Honk if You Love Dirty Air."²⁰

Despite the loud protests, paid parking has worked extremely well. When parking was free, downtown parking space occupancy during peak periods ranged from 95 to 100 percent, and finding a space was usually difficult. Average parking space occupancy declined to about 70 percent after paid parking began, and finding a parking space is usually easy. Most residents now support the paid-parking program.

Much to the horn-honkers chagrin, the paid-parking program was supported by a 3 to 1 margin by voters in the municipal election in May 1995. . . . Most downtown business people now agree that the attractiveness of available convenient parking for their shoppers and patrons has far offset any disadvantages of paid parking. Likewise, the Residential Permit program has helped residents of neighborhoods around the commercial core to find a place to park in the block on which they live instead of several blocks away. The municipal parking structure now fills routinely during the winter and summer months and has begun to generate surplus revenues that can be reinvested in transportation improvements. The paid parking programs are generating about \$600,000 a year in new revenues (out of a \$1.4 million total budget) over and above all parking-related expenses.²¹

Aspen's solution to the parking problem has several important advantages. It makes conveniently located parking spaces available to all who are willing to pay for them. It reduces traffic congestion and pollution emissions from cars searching for curb parking. It improves urban design. And it generates substantial revenue for the city. Aspen's success therefore raises an important question. If charging the market price for parking is so easy, and works so well in Aspen, why don't most cities do it? The answer to this question lies, I believe, with the distribution of parking meter revenue. I will conclude by arguing that a fair distribution of the revenue will lead citizens to insist on charging market prices for curb parking

PARKING BENEFIT DISTRICTS

Money that you feed into a parking meter almost vanishes into thin air. Who *does* receive the money that parking meters swallow, and how is it spent? According to the only survey on the question, 60 percent of all cities deposited their parking meter revenues into their general funds, and 40 percent deposited them into special funds that typically were used to provide public off-street parking.²² Few motorists want to feed either the general fund or special parking funds, and cities have found it politically easier to require off-street parking rather than charge for curb parking.

If the yearning to park free is such a powerful political argument for cities *not* to charge for curbside parking, why did 75 percent of the voters in Aspen support market prices for their curbside parking? One explanation is that 5,000 residents benefit from the payments for parking by 25,000 nonresidents. Aspen has followed Monty Python's advice to tax foreigners living abroad, and I will argue that other cities can do the same. How can a city allocate its parking meter revenues so that residents will want the city to charge market prices for curbside parking?

My proposal is for cities to dedicate each neighborhood's curbside parking revenue to pay for public services in the neighborhood where the revenue is earned. If each neighborhood charges *nonresidents* for parking and spends all of the revenue to improve the neighborhood, market prices for curbside parking can become a popular neighborhood revenue source. The residents' desire to improve their neighborhood with money paid by nonresidents will create the necessary political support for market-priced curbside parking.

To explain the proposal for neighborhood-based curbside parking charges, I will describe two settings in which market prices for curbside parking can be politically popular: (1) commercial districts and (2) residential neighborhoods.

BUSINESS PARKING BENEFIT DISTRICTS

First, consider the case of an older commercial district where off-street parking is scarce and most customers rely on curbside parking. Parking is hard to find because the meter price of curbside parking is below the level that leaves a few spaces vacant. The streets are congested with cars hunting for a parking space about to be vacated, and everyone complains about the parking shortage. Raising the price of curbside parking will create a few vacancies, eliminate the need to hunt for parking, reduce traffic congestion, and produce revenue, but merchants typically fear that higher meter rates will chase customers away.

Suppose in this situation the city creates a "Business Parking Benefit District" where the city dedicates all parking meter revenue to pay for public services in the district—such as cleaning the sidewalks, planting street trees, providing bus shelters, and removing graffiti. Therefore, curbside parking revenue will pay for public amenities that attract customers to the local businesses. Dedicating the revenue to improving the area where it is collected can create a strong local self-interest in using market prices to solve the parking problem.

The goal of pricing curb parking is to yield about an 85 percent occupancy rate so that drivers can quickly find a place to park near their destination.²³ The price should be reduced if there are too many vacancies, and increased if there are so few vacancies that drivers must drive around to find a place to park. The total number of curb spaces will not shrink, and market prices will ensure that drivers can always find a few vacant parking spaces wherever they want to park. Parking may not be free, but it will be easy to find.

The market price for curb parking will not “chase away” potential customers who would park at the curb if the price were lower. *The market price of parking is the price that keeps only a few spaces vacant to allow convenient access*. A below-market price will create a parking shortage that *does* chase potential customers away. The purpose of charging market prices for curb parking is to allocate curb parking spaces efficiently, not to maximize meter revenues.

Market prices will allocate curb parking to drivers who are willing to pay for it without having to hunt for a vacant space. If parking prices are high enough to ensure vacancies, those who arrive in higher-occupancy vehicles will pay less per person because they can split the parking charge. Those who park for only a short time will also pay less because they use less parking time per trip. Therefore, market prices will (1) ensure that everyone can park quickly, (2) favor shoppers who arrive in higher-occupancy vehicles, and (3) encourage parking turnover by favoring shoppers who stay a short time. Market prices for curb parking will thus attract more customers who will spend more in the adjacent shops because more drivers and passengers per hour will use each curb parking space. In contrast, free parking allocates curb spaces to drivers who will spend a long time hunting for a rare vacant space and park longer once they find it.

A PRECEDENT: BUSINESS IMPROVEMENT DISTRICTS

Business Improvement Districts (BIDs) are a precedent for the proposed Business Parking Benefit Districts. BIDs are special taxing jurisdictions formed by merchants and landowners to finance improvements that benefit their area. They are self-governing public/private partnerships, and they have spread rapidly since the first one was formed in Toronto in 1965.²⁴ Many cities encourage the establishment of these BIDs to finance public improvements in older commercial areas. BIDs are thus ready-made recipients for curb parking revenue, and their governing boards are legitimate bodies that can decide how to spend parking meter revenues earned in their districts.

Suppose that a city offers to dedicate to a BID the parking meter revenue earned within the BID. This arrangement amounts to a matching grant to finance the BID. The parking revenue will either reduce the taxes that businesses must pay to the BID or increase what the BID can spend. This matching-grant arrangement will encourage local businesses to form BIDs. If the total revenue from market-priced curb parking in a business district is high enough to finance a BID's total expenditures, the merchants and landowners will receive a free BID. The purpose of BIDs is to finance public improvements in older commercial areas, so using parking meter revenue to encourage the formation of BIDS will stimulate commercial revitalization.

Dedicating curb parking revenue to fund BIDs will encourage businesslike management of curb parking. There can be no quicker way to educate businesses about the best policy toward curb parking in their neighborhood than to give them control over parking revenue and pricing decisions. Each BID can examine how other BIDs deal with curb parking, and they can weigh the benefits and costs of alternative policies—such as free parking versus market-priced parking. BIDs will have every incentive to choose the best policy toward curb parking for their area because they will be the first to suffer from their own bad decisions. For example, BIDs can see that they will increase their revenues by installing more parking meters, extending meter hours, or increasing meter rates. They can also see that market-level prices will encourage parking turnover, so that more curb spaces will be available to short-term parkers.

If curb parking revenue finances a BID, merchants will also see that drivers who park at meters without paying are reducing the revenue available to fund public improvements in the immediate area. Parking without paying may therefore come to be seen like shoplifting from the BID, and merchants should therefore be eager to support meter enforcement. The city will receive the citation revenue, which often exceeds the revenue from parking meters themselves, so even the city's general fund can gain from dedicating parking meter revenue to BIDs.

If cities use market prices to manage curb parking efficiently in business districts, they will no longer need to require off-street parking in these districts. Businesses can voluntarily provide or validate off-street parking for their own customers and employees, but urban planners will not need to *require* off-street parking to prevent on-street parking congestion.

CREATING A MARKET FOR PARKING IN RESIDENTIAL NEIGHBORHOODS

Dedicating curb parking revenue to BIDs will encourage merchants and property owners to form BIDs, and it will encourage them to support charging market prices for scarce curb spaces. These market prices for curb parking will also allow cities to reduce or eliminate off-street parking requirements. But charging for curb parking and eliminating minimum parking requirements in commercial districts can cause parking spillover into nearby residential neighborhoods. Many neighborhoods already suffer spillover from adjacent commercial areas, and eliminating parking requirements might make this situation even worse. How can cities avoid this problem?

Many cities solve the problem of parking spillover into residential neighborhoods by creating Residential Parking Permit (RPP) districts that reserve on-street parking spaces for residents and their guests. For example, high-rise office buildings and hotels are often near single-family residential neighborhoods, but RPP districts have eliminated parking spillover into these neighborhoods by reserving curb parking for residents. RPP districts have spread rapidly throughout the United States since 1977 when the U.S. Supreme Court upheld the constitutionality of the statute in Arlington, Virginia that set up the first RPP district in the United States.²⁵

Despite their advantages, RPP districts create a high vacancy rate for curb parking in residential neighborhoods while nearby commercial developers must build expensive parking structures for commuters and customers. The many underused curb parking spaces in RPP districts are an overreaction to the problem of overused free curb parking.

As an alternative to both overused and underused curb parking, creating a market in curb parking offers important benefits to residents *and* nonresidents. The goal of creating this market is not merely to reduce the political opposition to pricing curb parking, but also to generate strong political support for it.

To set the scene for this market, suppose you own a home near a busy commercial district that generates spillover parking into your neighborhood. Strangers park in front of your house all day, every day. You can't find a place to park your own car on the street, and neither can your guests. Suppose also that the city will install a parking meter at the curb in front of your house, and *you* get to keep all the revenue. As a resident you can park free at your own meter, but you can also make your curb parking space available to the public rather than occupy it yourself. Finally, suppose

that a meter rate of \$1 an hour on your block will produce a 15-percent vacancy rate, so that anyone willing to pay that price can always find parking. At this price and vacancy rate, your parking meter will yield \$7,446 a year if you make your curb space available to the public²⁶ Or you can park free in front of your house.

Curb parking can also yield substantial revenue even where the demand is modest. At a price of 50¢ an hour for 8 hours each weekday—and no charge at night or on weekends—each curb space will yield \$884 a year.²⁷ In comparison, the median property tax for owner-occupied housing in the United States is \$1,020 a year.²⁸ Because many neighborhoods have two curb parking spaces in front of each house, curb parking revenue can *easily* exceed the current property tax revenue in neighborhoods subject to spillover parking.

Although these private parking meters would lead many residents to demand market prices for curb parking, cities cannot give private property owners the revenue from parking on public streets. Is there another solution that can create political support for market prices without simply giving the revenue to property owners? I believe that there is, and it requires only a minor modification to existing Residential Parking Permit districts

RESIDENTIAL PARKING BENEFIT DISTRICTS

My proposal is to create residential Parking Benefit Districts. The new Parking *Benefit* Districts resemble conventional Parking *Permit* Districts in that residents can park free on the streets in front of their homes. The Benefit districts *differ* from conventional Permit districts in two ways

1. *Nonresidents* can park on the streets in a Parking Benefit District if they pay the fair market price.
2. The city earmarks the resulting curb parking revenue to finance additional public services in the neighborhood where the revenue is collected.

The price for *nonresident* parking in a Parking Benefit District is set high enough to ensure that vacancies are always available for residents (who park free) and nonresidents (who pay to park). The new revenue can finance additional public services, beyond the conventional public services provided everywhere in the city.²⁹ For example, the curb parking revenue can be used to clean the streets, repair the sidewalks, plant trees, remove graffiti, preserve historic buildings, or put utility wires underground in the neighborhoods where the revenue is collected. The residents who receive these additional public services will *want* nonresidents to pay the fair market price for parking in

their neighborhood. Nonresidents will also benefit from benefit districts that allow parking at a fair market price rather than simply prohibit parking at any price.

A few cities already allow nonresidents to pay to park in permit districts. As mentioned earlier, Aspen charges nonresidents \$5 a day to park in its permit districts. West Hollywood, California sells a limited number of permits allowing daytime parking by employees of nearby commercial areas, and the permit fees paid by these commuters are used to lower the permit fees charged to residents. Because many residential permit holders drive to work during the daytime and park on their own streets only in the evening, commuters who work in the area and residents who live in the area time-share their curb parking spaces.

The simplest way to convert an existing *permit* district into a new *benefit* district is to sell “daytime” permits that allow nonresidents to park in the district while many of the residents have taken their cars to work. The residents of an existing permit district might be happy to have a few employees of nearby business pay the market price to park in the neighborhood if the revenue is dedicated to improving the neighborhood. Residents who benefit from parking charges paid by strangers will begin to see curb parking through the eyes of a parking lot owner. Seen from the residents’ side of the transaction, a parking benefit district will collect and spend curb parking revenue to make the neighborhood a place worth living in and visiting, rather than merely a place where anyone can park free.

The *economic* argument to charge market prices for curb parking is *efficiency*—the benefits far outweigh the costs. Drivers will not need to hunt for curb parking, and cities will not need to require off-street parking. The *political* argument to create parking benefit districts is *distribution*—the benefits for the neighborhood can lead residents to support market prices for curb parking. Curb parking revenue needs the appropriate claimant—its own neighborhood—before residents will advocate market prices for parking.

Parking benefit districts will grant to neighborhoods a valuable, income-earning property—curb parking spaces. Charging for curb parking can be politically acceptable because residents want to improve neighborhoods at the expense of nonresidents. The reciprocal nature of the payments—you pay to park in my neighborhood, but I pay to park in yours—is fair. In addition, motorists will compensate neighborhoods that suffer from spillover parking, and this also is fair.

DO IT IN MY FRONT YARD

If curb parking is free, most nearby residents will say “Not in My Back Yard” to developers who want to provide fewer parking spaces than required by the zoning code. For example, where the minimum parking requirement for an office building is four spaces per 1,000 square feet, residents will obviously oppose the nearby development of a new office building with only one parking space per 1,000 square feet. Spillover parking from the new building would congest their streets and leave them no curb spaces to park their own cars.

A parking benefit district will create a symbiotic relationship between commercial development and its nearby residential neighborhood because any commuters who park in the neighborhood will pay for the privilege. Charging market prices for curb parking can solve the spillover problem because prices can be set to yield any curb vacancy rate the neighborhood wants. Commercial development that has few off-street parking spaces will increase the demand for what the nearby neighborhoods sell to nonresidents—curb parking. Residents who collectively profit from curb parking might welcome a new office building with few off-street parking spaces because it will increase their parking revenue without increasing the number of cars parked at the curb.

The higher price for parking at an office building with fewer parking spaces will divert some commuters to carpools, mass transit, cycling, or walking to work. An office building with fewer off-street parking spaces will thus attract fewer vehicle trips, another benefit for the nearby neighborhoods. This combination of benefits—fewer vehicle trips but more revenue for neighborhood public services—may lead residents to say “Do It in My Front Yard” when a proposed development will increase the demand for curb parking.

Emancipated from minimum parking requirements, land and capital will shift from parking to uses that employ more workers and generate more tax revenue. The option to make improvements without providing off-street parking will encourage adaptive reuse of older buildings, and infill development on sites where providing parking is difficult. It will also encourage land uses that rely on pedestrian and transit access, and that offer shopping opportunities for nearby neighborhoods.

In general, older and denser central cities built before the automobile will gain much more from RPB districts than will newer suburbs built to accommodate the automobile. Neighborhoods that now suffer the most from spillover parking will immediately earn the most RPB revenue.

Spillover parkers who now congest these neighborhoods will become paying guests, their numbers kept manageable by charging prices high enough to keep demand below capacity (just as commercial parking operators charge prices high enough to maintain vacancies). These neighborhoods might prosper like silent screen star Gloria Swanson in *Sunset Boulevard*, who explained to young William Holden the source of her income:

I've got oil in Bakersfield, pumping, pumping, pumping. What's it for but to buy us anything we want?

Each outsider's car will become a new resource "pumping, pumping, pumping" revenue to buy anything the neighborhood wants. If the price of curb parking is set high enough so that everyone can easily find a vacant space, curb parking revenue in neighborhoods subject to significant parking spillover can easily exceed the current property tax revenue.³⁰ After a few neighborhoods profit from charging outsiders for parking, many other neighborhoods will surely follow.

CONCLUSION: WE SHALL OVERCOME

Parking requirements in zoning ordinances bundle the cost of parking into the prices for all goods and services. Parking requirements thus "collectivize" the cost of parking, and we cannot reduce what we pay for parking by using less of it. In contrast, market prices for parking "individualize" the cost of parking, and they give us an incentive to economize in our decisions about whether to own or drive a car.

Off-street parking requirements emerge from a political, not an analytical, process, and better analysis alone will not affect this process. But the technology of charging for curb parking has radically improved in recent years. The political calculus that produces free curb parking and off-street parking requirements can change to keep pace. Voters will want to charge market prices for curb parking if the city dedicates the resulting revenue to the right recipient—the neighborhood where the revenue is collected.

The constraints on charging for curb parking are now political rather than technological. Aaron Wildavsky described this situation perfectly: "Constraints are not mere obstacles, but are opportunities asking (daring, pleading) to be shown how they can be overcome."³¹ Technology no longer constrains curb parking to be free, and public concern has shifted to problems that off-street

parking requirements make worse, such as traffic congestion, energy consumption, and air pollution.³² Free curb parking is a constraint asking, daring, pleading to be overcome.

ENDNOTES

- 1 The 1990 Nationwide Personal Transportation Survey (NPTS) asked respondents, "*Did you pay for parking during any part of this trip?*" for all automobile trips made on the previous day. Ninety-nine percent of the responses to this question were "*No.*" Free parking at home does not help to explain the high percentage of trips with free parking because the NPTS asked the "pay for parking" question for all vehicle trips *except* the trips that ended at home. *Monopoly*® is the trademark of Hasbro, Inc. for its real estate trading game. See Stewart (1996) and Collins (1998) for the probability of landing on "Free Parking" in the game of *Monopoly*.
2. The total of 230 billion vehicle trips per year was calculated from the "travel day" file in the 1995 Nationwide Personal Transportation Survey. The 177 million licensed drivers in 1995 made about 1,300 one-way vehicle trips per person per year (230 billion – 177 million), or about 1.8 round-trips per day.
- 3 As soon as motorists park their cars and assume another role—to shop, eat in a restaurant, go to a movie—they begin paying for parking, but this payment is bundled into the prices for merchandise, food, or movies, and it will not affect the decision on how to travel to the store, restaurant, or movie theater.
4. Hardin (1968, 1245) was describing Leominster, Massachusetts, but many other cities offer this seasonal gift to motorists.
5. Weant and Levinson (1990, 35-37). Similarly, the PAS (1971, 3) reports that in surveys to determine parking demand, "Most of the developments studied provided adequate parking spaces to meet the observed peak demand without overflow conditions. This was important because in order to develop standards for parking space requirements, the peak demand had to be identified."
6. The 1990 Nationwide Personal Transportation Survey (NPTS) asked 48,000 respondents, "*Did you pay for parking during any part of this trip?*" for all automobile trips made on the previous day. Ninety-nine percent of the 56,733 responses to this question were "*No.*" The responses outnumbered the respondents because some respondents made more than one automobile trip per day.
- 7 See Los Angeles City (1989, p. 616).
8. Neraci (1985, 77).
9. The Reverend C. H. North was the first motorist cited for overstaying a parking meter's time limit. The Reverend's then-novel excuse that he "had gone to get change" persuaded the judge to dismiss the citation (*Allright Parking News*, Summer 1985, 5).
10. Demsetz (1964, 14). Demsetz referred to parking in shopping centers rather than at the curb. De Alessi (1983, 66) also used parking as an example to explain why transactions costs imply that

the rights to some resources will not be priced. One reason that parking in shopping centers was too cheap to meter, however, is that minimum parking requirements increase the supply and reduce the market price of off-street parking.

11. Ready (1998, 7).

12. Ready (1998, 10).

13. Ready (1998, 11).

14. Van Horn reports an additional advantage of multispace meters: "Berkeley has some areas where the parking rules change space by space. For example, in three of the space controlled by a unit, there is no parking from 7 a.m. to noon. In other spaces controlled by the unit, parking is available from 9 a.m. to 6 p.m. The machine displays which spaces are available during which times, and if a parker selects a space that is illegal during the that time, the unit will so note and not allow the parker to insert a coin."

15. "Parking Meters Going High-Tech in Berkeley," *San Francisco Chronicle*, August 30, 1999

16. If the driver overstays the time limit, the time display becomes negative and the excess time is shown; traffic enforcement officers can then issue a ticket just as they do when a conventional parking meter shows a violation. Alternatively, the city can set in-vehicle meters to charge for parking at an accelerated rate for those who overstay the time limit. The driver inserts the smart card at the beginning of the transaction, and removes it while the meter is left in the car. The next time the driver inserts the smart card in the meter, the time used during the previous parking is deducted from the value left in the smart card. Several websites explain these in-vehicle meters. For example, see <http://www.park-o-pin.de/index_1024.htm>.

17. *Public Technology*, November/December 1990, p. 4.

18. Ready (1998, 9). In 1996 Aspen received the International Parking Institute's Award of Excellence for its transportation and parking plan.

19. "Groningen First City Introducing High Tech Parking," *Parking Expert*, September 2001. Available online at <http://docs.vercomnet.com/mobility/parking_vc/mobile_parking.htm>. See also "Groningen Goes Cashless," *ITS International*, September/October 2001, pp. 51-52. Available online at <<http://www.itsinternational.com/mag/index.htm>>. See also "Dutch City Introducing Mobile Internet Cashless Parking," *Parking Today*, Vol. 6, No. 8, pp. 24-26.

20. Ready (1998, 7)

21. Ready (1998, 8 and 12).

22. Robertson (1972).

23. Shoup (1999).
24. Houstoun (1997) explains the details of planning, organizing, and managing Business Improvement Districts.
25. “*County Board of Arlington County, Virginia, et al. v Rudolph A Richards, et al.*” October 11, 1977.
26. $\$7,446 = \$1 \times 24 \times 365 \times 0.85$. If the demand for parking in front of your house is inelastic, a higher price will produce both a higher vacancy rate and even more revenue. For example, if a price of \$2 an hour produced a 50-percent vacancy rate, your personal parking meter would yield \$8,760 a year ($\$2 \times 24 \times 365 \times 0.50$). After some experimentation, you could find the price of parking that yields a combination of vacancy rate and total revenue that suits you best, just as the owners of off-street parking lots do.
27. This includes the effect of a 15-percent vacancy rate: $\$884 = 8 \times \$0.50 \times 5 \times 52 \times 0.85$.
28. American Housing Survey for the United States in 1995, Table 3-13, “Selected Housing Costs—Owner Occupied Units.”
29. That is, the city agrees to a “maintenance of effort” for general public services provided in the new district. The parking revenues will provide *additional* public services in the district
30. Shoup (1995, 23)
31. Wildavsky (1979, 59)
32. Columbus, Ohio introduced the country’s first minimum parking requirement in 1923, and Oklahoma City introduced the country’s first parking meters 12 years later, in 1935 (Witthford and Kanaan 1972).

REFERENCES

- De Alessi, Louis. 1983. "Property Rights, Transaction Costs, and X-Efficiency. An Essay in Economic Theory," *American Economic Review*, March 1983, Vol. 73, No. 1, 64-81.
- Demsetz, Harold. 1964. "The Exchange and Enforcement of Property Rights," *Journal of Law and Economics*, October 1964, Volume 7, 11-26.
- Hardin, Garrett. 1968. "The Tragedy of the Commons," *Science* 162, pp. 1243-48.
- Houstoun, Lawrence. 1997. *BIDs: Business Improvement Districts* Washington, D.C.: Urban Land Institute in cooperation with the International Downtown Association.
- Los Angeles City 1989. *Planning and Zoning Code, 1989 Edition* Los Angeles: Bni Books.
- Neraci, Jack. 1985. "The First Parking Meter," *Motor Trend*, November 1985, 77
- Pickrell, Don and Paul Schimek. 1999. "Growth in Motor Vehicle Ownership and Use Evidence from the Nationwide Personal Transportation Survey," *Journal of Transportation and Statistics*, Volume 2, Number 1, May 1999, 1-17.
- Ready, Randy 1998 "Public Involvement, Understanding, and Support: Lessons Learned from the City of Aspen Transportation and Parking Plan," *Journal of Parking*, Vol. 1, No. 2, 7-12.
- Robertson, William. 1972. *National Parking Facility Study* Washington, D C.: National League of Cities.
- Shoup, Donald 1995 "An Opportunity to Reduce Minimum Parking Requirements," *Journal of the American Planning Association*, Vol. 61, No. 1, 14-28.
- Shoup, Donald 1999. "The Trouble with Minimum Parking Requirements," *Transportation Research A*, Volume 33, 549-574.
- Van Horn, John. 1999. "Berkeley Makes the Move to Multi-Space Parking Meters," *Parking Today*, Vol. 4, No. 8, September 1999, 42-44
- Weant, Robert and Herbert. Levinson. 1990. *Parking* Westport, CT: Eno Foundation for Transportation.
- Wildavsky, Aaron. 1979. *Speaking Truth to Power*. Boston, MA: Little, Brown and Company.
- Witheyford, David K. and George E. Kanaan 1972. *Zoning, Parking, and Traffic*. Westport, CT. Eno Foundation for Transportation.