

Lawrence Berkeley National Laboratory

Lawrence Berkeley National Laboratory

Title

RESEARCH ON HIGH BEAM-CURRENT ACCELERATORS

Permalink

<https://escholarship.org/uc/item/2xk9k8wf>

Author

Keefe, Denis

Publication Date

1981-04-01



Lawrence Berkeley Laboratory

UNIVERSITY OF CALIFORNIA

Accelerator & Fusion Research Division

To be published in Particle Accelerators

RESEARCH ON HIGH BEAM-CURRENT ACCELERATORS

Denis Keefe

April 1981

TWO-WEEK LOAN COPY

*This is a Library Circulating Copy
which may be borrowed for two weeks.
For a personal retention copy, call
Tech. Info. Division, Ext. 6782*

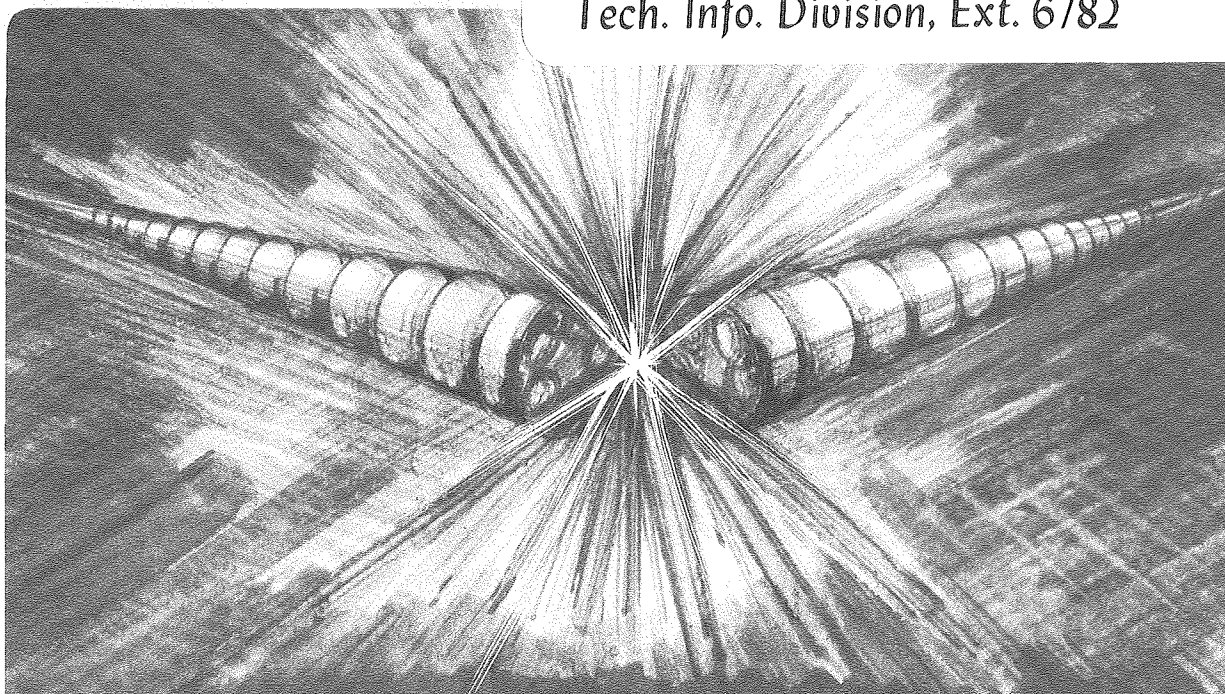

LBL-12210
c. 2

DISCLAIMER

This document was prepared as an account of work sponsored by the United States Government. While this document is believed to contain correct information, neither the United States Government nor any agency thereof, nor the Regents of the University of California, nor any of their employees, makes any warranty, express or implied, or assumes any legal responsibility for the accuracy, completeness, or usefulness of any information, apparatus, product, or process disclosed, or represents that its use would not infringe privately owned rights. Reference herein to any specific commercial product, process, or service by its trade name, trademark, manufacturer, or otherwise, does not necessarily constitute or imply its endorsement, recommendation, or favoring by the United States Government or any agency thereof, or the Regents of the University of California. The views and opinions of authors expressed herein do not necessarily state or reflect those of the United States Government or any agency thereof or the Regents of the University of California.

RESEARCH ON HIGH BEAM-CURRENT ACCELERATORS*

Denis Keefe

Lawrence Berkeley Laboratory
University of California
Berkeley, California 94720
and
Physical Dynamics, Inc.
P.O. Box 1883
La Jolla, CA 92038

April 1981

*This work was supported by the Director, Office of Energy Research, Office of High Energy and Nuclear Physics, High Energy Physics Division of the U. S. Department of Energy under Contract No. W-7405-ENG-48, and in part by Physical Dynamics, Inc.

RESEARCH ON HIGH BEAM-CURRENT ACCELERATORS*

Denis Keefe

Lawrence Berkeley Laboratory
University of California
Berkeley, CA 94720 USA
and
Physical Dynamics, Inc.
P.O. Box 1883
La Jolla, CA 92038

I. INTRODUCTION

Apart from traditional accelerator research in support of present and proposed accelerators for High Energy and Nuclear Physics,¹ there is a considerable body of active research in the U.S. on accelerating devices and concepts of a novel nature. This paper is intended as a current review of the latter category; it is somewhat selective, however, in that a description of intense heavy ion accelerators for application to inertial fusion has been omitted on the grounds that extensive reviews on that topic already exist.² Programmatically, these activities span a broad range of risk/benefit ratios ranging from extension of existing parameters for accelerators with well-established principles of operation to the exploration of speculative concepts that may in the future provide new tools for accelerator physicists to deploy in constructing novel types of accelerators or in expanding the capability of more traditional machines. Likewise, there is a broad spectrum of funding

*"This work was supported in part by the Director, Office of Energy Research, Office of High-Energy and Nuclear Physics, High-Energy Physics Division of the U.S. Department of Energy under Contract No.-7405-ENG-48, and in part by Physical Dynamics, Inc."

levels ranging from a wide variety of exploratory programs (at >100 k\$/year level) through a small number of selected well-supported programs (>1 M\$/year level), to a single significantly large construction program (ATA at approximately ~ 10 M\$/year). In general, all these programs are concerned with producing very high beam current in a pulsed mode and with the potential for later being scaled to large beam energy (joules, not MeV).

It is important to note that attention in all these programs has been focused on producing beams with kinetic energies less than 1 GeV, and it will be seen that a rich variety of novel ideas and tools has been developed. Hitherto, there has been almost no stimulus to address, in a similar way, the applications of some of these concepts to ultra-relativistic particle beams (100 GeV and more) for high-energy physics applications. Given such a stimulus, it could well be that the ingenuity that has been brought to bear on solving the medium-energy high-current electron and proton beam problems could, in the future, lead to novel advances in the art of High Energy Physics particle beams.

Broadly speaking, the programs to be discussed fall into two categories:

1. Non-Collective Systems: These include rf linacs (for ions) and a variety of induction linacs (for electrons); here one relies on externally produced ("conventional") electric and magnetic fields for focusing and acceleration.
2. Collective Devices and Concepts: This category can be sub-divided into cases where the collective electric field is primarily being used:
 - (a) radially, (E_r), to provide transverse focusing of intense ion beams (protons or electrons); or

(b) axially, (E_z), to provide very strong accelerating fields for ions (protons); in all such cases the radial component of the electric field, E_r , also acts to constrain the beam laterally.

It is convenient to distinguish between these broad categories in the following way. If one ignores the charge on the particles in the accelerator beam itself then at the location of the beam we have for Category 1:

$$\text{Div } \underline{E} = 0, \text{ and } \text{Curl } \underline{B} = 0 \quad (1)$$

and for Category 2:

$$\text{Div } \underline{E} = \rho, \text{ and, sometimes, } \text{Curl } \underline{B} = \underline{j} \neq 0. \quad (2)$$

In the one case the fields are produced by external conductors and have constraints set by the mechanical and surface properties of solid materials; in the other case, charged particles (electrons and/or ions) are present in free space at and near the beam location to provide fields that are not subject to the conventional boundary conditions either mechanical or electrical. It is this latter feature that has led to the very wide variety of collective-effect devices that has been suggested. The other side of the coin is that often the electron beam used to manipulate the intense ion beams is of even higher intensity and must itself be amenable to outside control and regulation.

II. CATEGORY 1: NON-COLLECTIVE SYSTEMS

Devices that fall under this heading include a high-current rf linac, and a variety of induction linacs.

II.1. Ion Acceleration

High-brightness rf linac at Los Alamos Scientific Laboratory: The aim of this program is to produce a cw beam of 100 mA of H^- ions of very small emittance ($\pi\epsilon N = 2\pi \times 10^{-7}$ meter-radians) from an rf linear accelerator. The goal of the present test-stand experiment is to accelerate the beam to 4.5 MeV and show that optical quality of the beam meets this goal. A high-quality 100 mA beam, i.e., of satisfactory emittance, of H^- ions has been successfully generated from a pulsed (~1 msec) Dimov-Dudnikov source.³ A rotating version of this source that will allow for heat dissipation and permit d.c. operation is being developed.

The initial plans call for the acceleration of the beam through a 200 kV electrostatic column and an examination of the beam emittance at the exit to see if it is still satisfactory. The beam would then be bunched and injected into an rf linac operating at 400 MHz. In the first sections of the linac, the emittance is expected to grow because of coupling of the transverse and longitudinal motion in the presence of collective self-fields of the intense beam. Extensive numerical simulation calculations of the emittance dilution have been made and are continuing. An elegant laser diagnostic to study this coupling experimentally will sample different points within each rf bunch; the focused laser light will convert a tiny volume of the negative ions to neutral atoms which can stream out of the machine, where their angular divergence and energy spread will be measured⁴ (see Fig. 1). The transverse and longitudinal emittance changes can thus be mapped out cell by cell along the length of

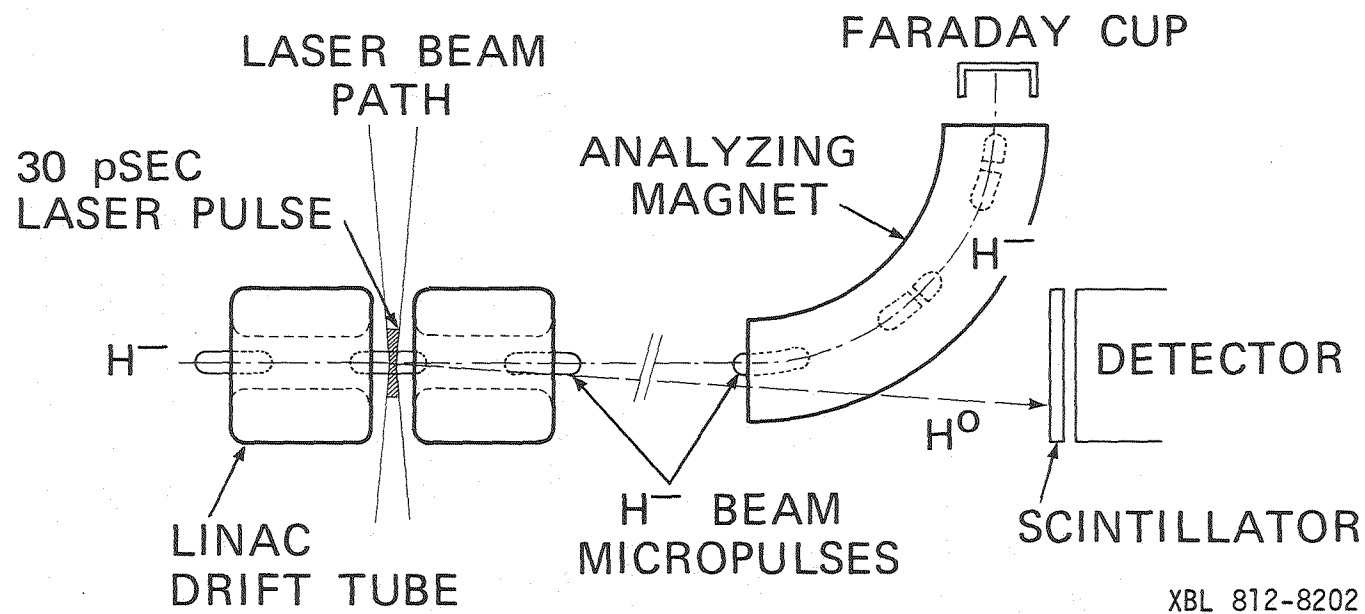

XBL 812-8202

Fig. 1

the first linac section. Emittance dilution in the front end of rf linacs has been known to exist for many years; this experiment should lead to an excellent understanding of the physical processes at work.

The results from another Los Alamos program to examine the radio-frequency quadrupole (RFQ) focusing and accelerating structure--recently proposed by Teplyakov and Kapchinsky⁵--has now caused a change in direction of the H⁻ linac program. Recent measurements with the RFQ structure have had highly promising results: emittance dilution is not severe, the capture efficiency is high and the optimum injection energy can be much lower than 200 keV. The consequent simplifications resulting from the use of the RFQ structure--at least for the first few MeV--make it an attractive alternative to the proposed test stand described above.

This program provides a good example of research in one area having spin-off into another--in this case High-Energy Physics. It was during the course of this research that the samarium-cobalt permanent magnet quadrupole, which can provide ultra-high gradients for focusing very narrow beams, was invented.⁶ It is now perceived that such quadrupoles can provide a crucial capability for handling the microscopic e⁺ and e⁻ beams at the intersection region in the single-pass electron-positron collider proposed at the Stanford Linear Accelerator Center.⁷

II.2. Electron Induction Linacs

An induction linac is made up of a succession of small pulse each timed to give an energy increment to the particles at the moment of passage of the beam.⁸ Pulse-power devices have the special advantage that the peak power capacity can exceed the average power rating by a factor of 10⁴

to 10^6 . (By contrast the size and cost of a pulsed radio-frequency system designed for a certain peak power turns out to be roughly the same as one that could deliver about one-tenth as much power on a cw basis.) Since, therefore, it is reasonable to supply power to each module at the gigawatt level and above,--usually at a voltage level in the 100 kV range--the induction linac is ideally suited (and efficient) for accelerating very large beam currents (100-100,000 Amps.). Most often, a Marx generator is used to charge a pulse-forming network or transmission line, the geometry of the line being so arranged that voltage of only one polarity (accelerating) is seen by the beam. For short beam pulses a vacuum or dielectric line can be used provided the double-transit time is adequately long; for long pulses a high impedance termination (ferromagnetic toroid) is used to exclude the unwanted polarity from the beam for as long as it takes the magnetic material to saturate. (See Fig. 2).

Advanced Technology Accelerator (ATA). At present under construction at Lawrence Livermore Laboratory this 50 MeV ferrite-loaded linac is intended to deliver 10,000 Amps of electrons in 50 nsec pulses.^{9,10} The average repetition rate is 5 Hz with a burst-mode capability of 1 kHz for 10 pulses. Water-filled Blumleins are used for the pulse-forming lines. The 2.5 MeV gun of the 5-MeV injector (ETA) has been completed and has so far delivered 80% of the design current at the desired repetition rate.¹¹ About 8kA of beam has been accelerated through further induction module stages to an energy of 4.5 MeV. The development of reliable high-voltage (250 kV) spark-gap switches to operate at 1,000 times per second was a significant technological advance.

Long Pulse Induction Linac. For pulse durations much longer than 100 nsec large volumes of ferromagnetic material are needed and ferrite

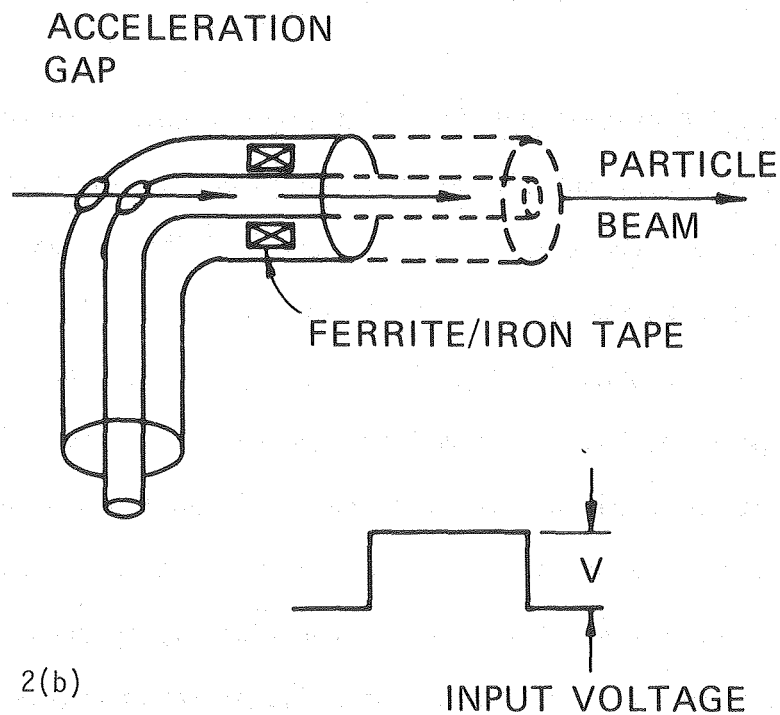
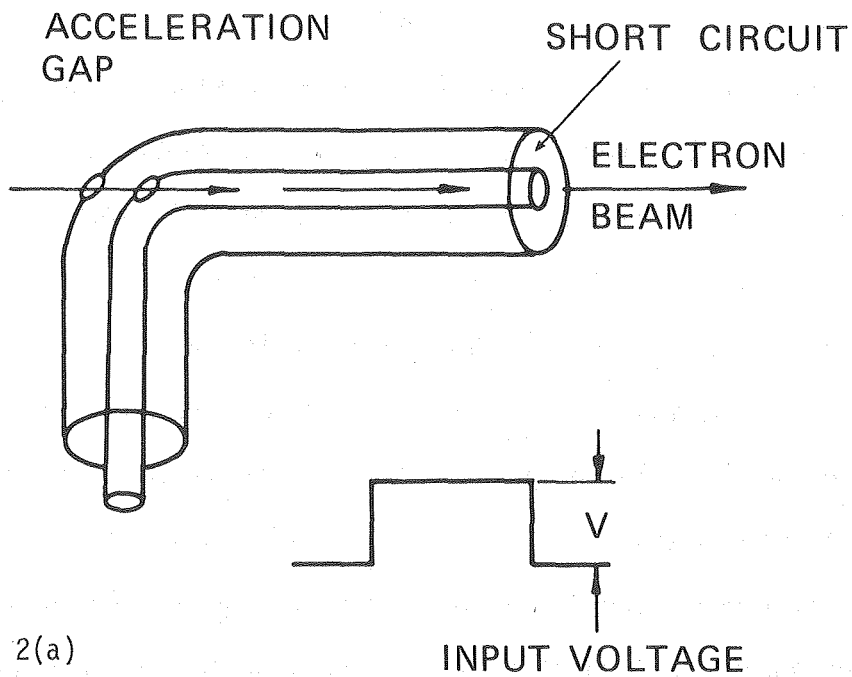

XBL 812-8201

Fig. 2

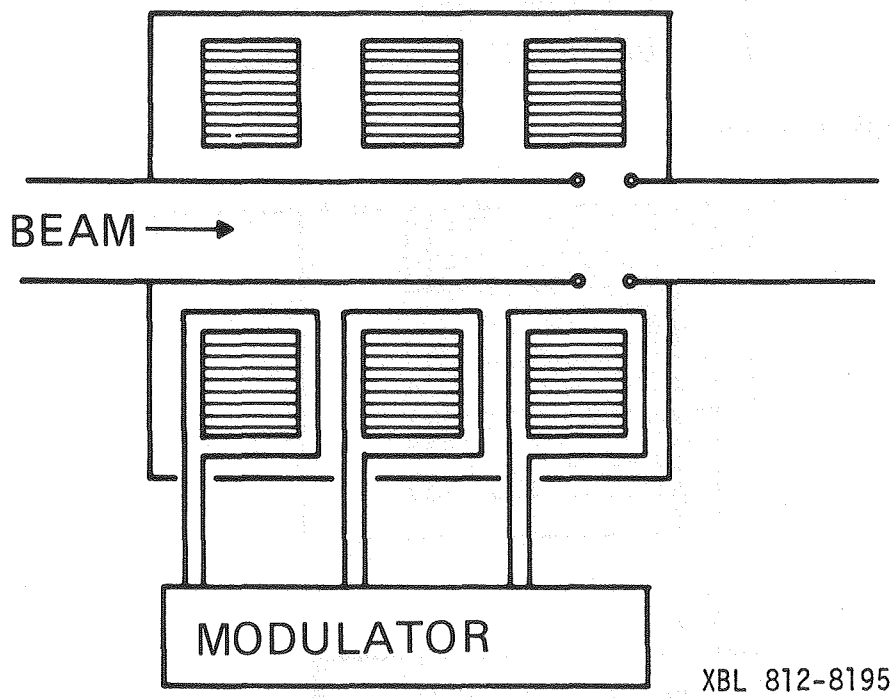

XBL 812-8195

Fig. 2(c)

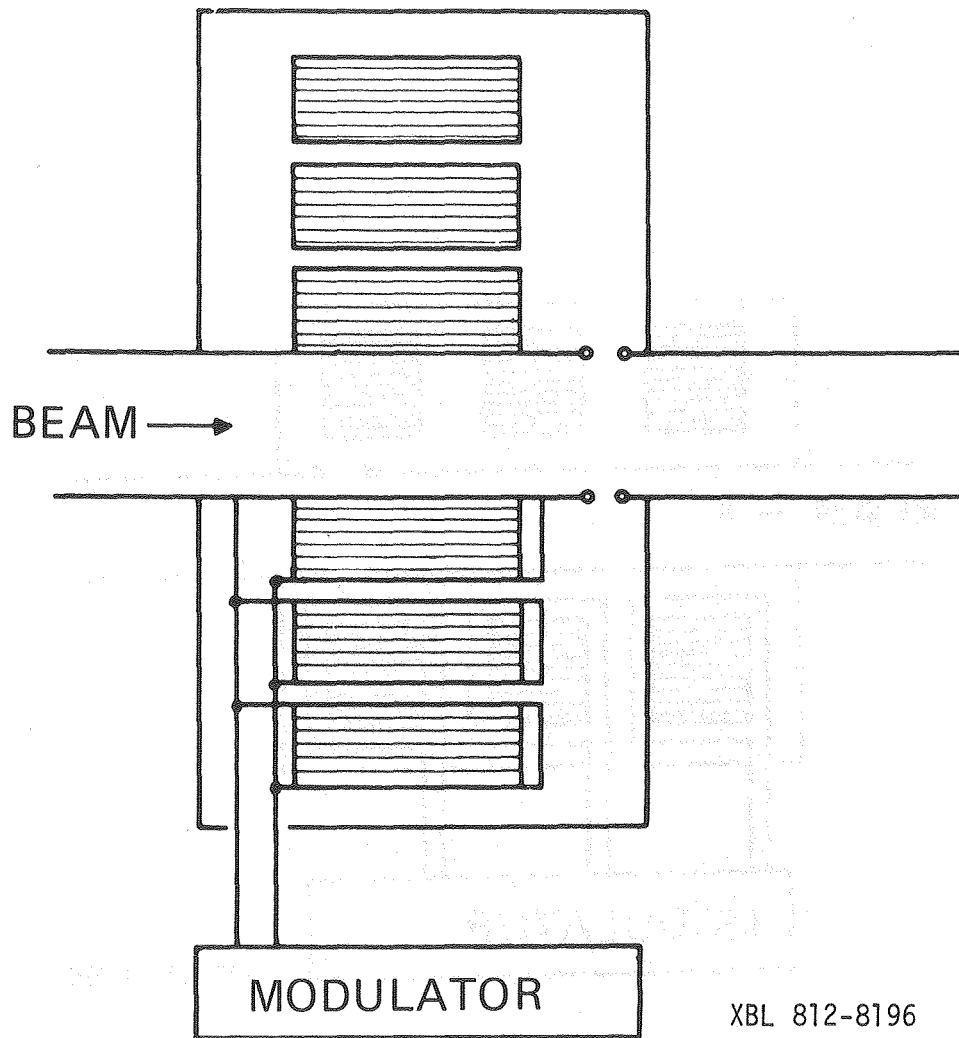

XBL 812-8196

Fig. 2(d)

becomes unduly expensive. The National Bureau of Standards has had a program (which will soon be discontinued) to address the problem of using thin (1-mil) inexpensive iron sheet, insulated layer to layer, as a core material suitable for a pulse duration of $2 \mu\text{sec}$.¹² In addition, this design included the novel feature of stacking several (n) nested ferromagnetic toroids of successively larger radii. These can all be driven in parallel from a single pulse line (of voltage V) so that an accelerating voltage nV can be developed across a single gap. Such an arrangement leads to a reduction in the overall length of the accelerator at the expense of a more bulky transverse dimension. [See Fig. 2(d)].

The NBS machine was operated at 0.8 MeV and 1000 Amps electron beam current. Experiments with this beam gave a striking demonstration that a gas-focused beam can propagate for long distances in low pressure gas (1 to 30 Torr) and can even be bent through 360° with dipole magnets only (no additional focusing lenses are needed) for recirculation through the accelerating cavity.

Radial Line Accelerator (RADLAC) For short pulses ($\sim 20 \text{ nsec}$) the pulse-forming line can be a radial transmission line closed at the outer radius and, if one wishes to minimize the transverse size, it can be filled with dielectric. Such a device was first assembled in the USSR by Pavlovskij.¹³ The RADLAC consists of 4 such radial lines each supplying 2 MV across a 2-in. gap.¹⁴ With the use of a 2-MV pulse-power relativistic electron-beam (REB) diode as an injector, the final performance is intended to be acceleration to 10 MeV of a 50-kA annular electron beam with a pulse length of 15 nsec.

If one analyzes a transmission line initially charged to voltage V, which is suddenly shorted by a fast switch at one end, one finds the following

voltage behavior at the open-circuit end. The voltage remains at the value V for a single transit-time τ after switch closure; the propagating wave, $-V$ in amplitude, initiated by the short then arrives and reflects at the open-circuit end, with the voltage doubling to $-2V$. The resultant voltage amplitude is $(V-2V) = -V$ which persists for a double-transit time 2τ , by which time the pulse has returned from the shorted end, and is now inverted to $+V$. Thus it can be seen that, in the absence of losses, the output voltage will be a train of square pulses each 2τ long and alternating in amplitude from $+V$ to $-V$. The only exceptional pulse is the first one, which is only τ in length. For acceleration one can choose to use either the first pulse or, if the longer pulse length is desired, one of the later pulses.

Figure 3 shows how the radial lines are arranged in the RADLAC. Each consists of a flat inner conductor flanked on either side by slightly conical outer conductors to form a tapered line of constant impedance (~ 10 ohms). It is a "folded" geometry with both the switch and gap located at the inner radius. The oil-filled cavities are 3 m in diameter and of fairly simple sheet-metal construction. A circular hole in the center is surrounded by a graded insulator (which provides the oil-vacuum envelope) and allows for passage of the beam. Arranged symmetrically around the cylindrical insulator are eight self-closing oil switches that fire in synchronism as the potential on the inner conductor is brought up rapidly. During the passage of the beam, no field is present on the (shorted) switch side of the line, while the other side acts as an accelerating gap. Solenoid lenses provide magnetic focusing. The injector and the four cavities are now operating to produce a 25-kA beam at 9 MeV, with current losses of only 10 percent. The average accelerating gradient is 3MV/m.

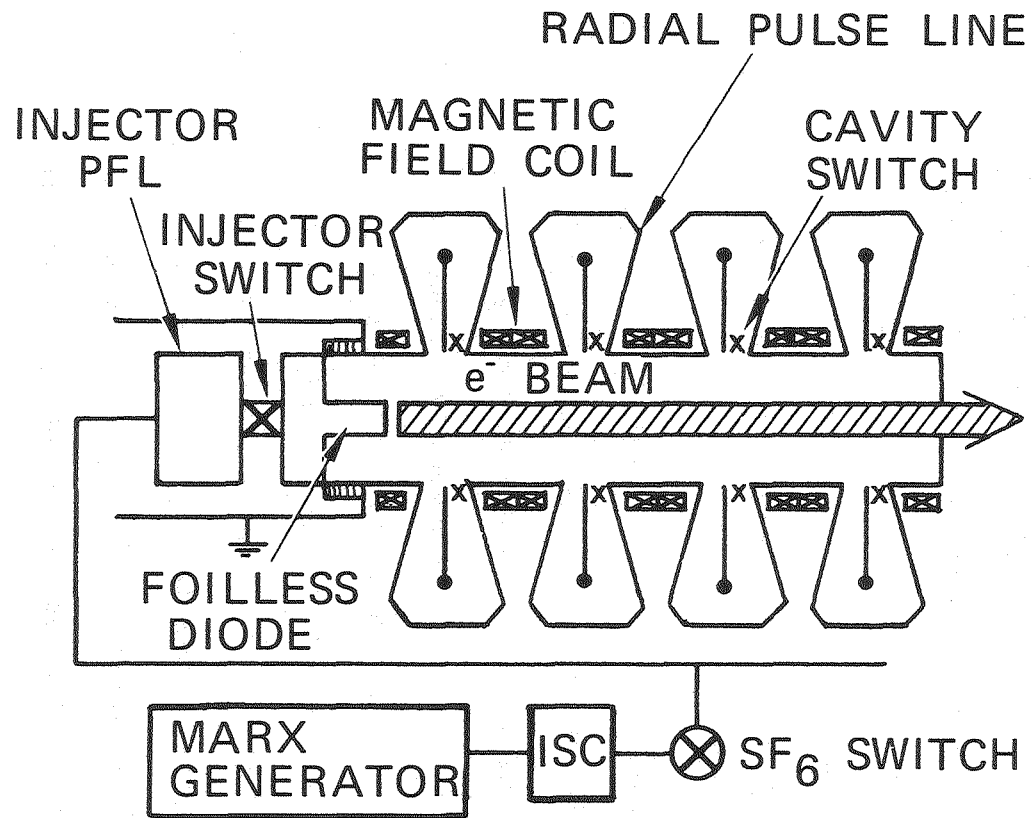

XBL 812-8199

Fig. 3

Auto-Accelerator: This program is an ingenious effort to exploit the high-current electron-beam technology that has been developed in the sub-10 MeV region to produce electron-beams at very much higher energies, perhaps in the range 100 - 1000 MeV.¹⁵ In contrast to the RADLAC geometry, the cavities have their long dimension (~ 1 m) in the axial, not the radial, direction (Fig. 4). Each cavity acts as a transmission line with a double transit time, $2\tau = 6$ nsec. The mode of operation is highly novel; an intense electron beam passing through the pipe is arranged to charge the cavities with magnetic energy on a slow time scale and this energy is later extracted quickly, in a double-transit time, to accelerate a 6-nsec pulse of electrons near the tail of the beam pulse.

The relativistic electron "charging" beam rises linearly from zero to $I = 30$ kA in a time of 800 nsec. The beam current $i(t)$ acts as a current source for the transmission line and instantaneously contributes a voltage, $Z_0 i(t)$, at the gap. If one follows how each such signal increment reflects back and forth along the line with inversion at the shorted end, a doubling at its first return to the open-circuit end and, in the absence of losses, repeated reflections of alternating sign thereafter, one can synthesize the voltage waveform developed across the gap. This turns out to be a linear rise to a value $Z_0 i(2\tau)$, followed by a linear fall to zero at $t = 4\tau$ and a repetition of this triangular form as long as the current rise continues. Thus, the average value of the gap voltage is $1/2 Z_0 i(2\tau)$. Bearing in mind that $Z_0 = (L/C)^{1/2}$ and $c = 1/(LC)^{1/2}$, we find that this voltage is equal to $(Lc\tau) di/dt$, where $Lc\tau$ is the lumped-element (long time-scale) inductance of the coaxial cavity. The sign of this voltage is such as to provide a slight deceleration of the electron beam.

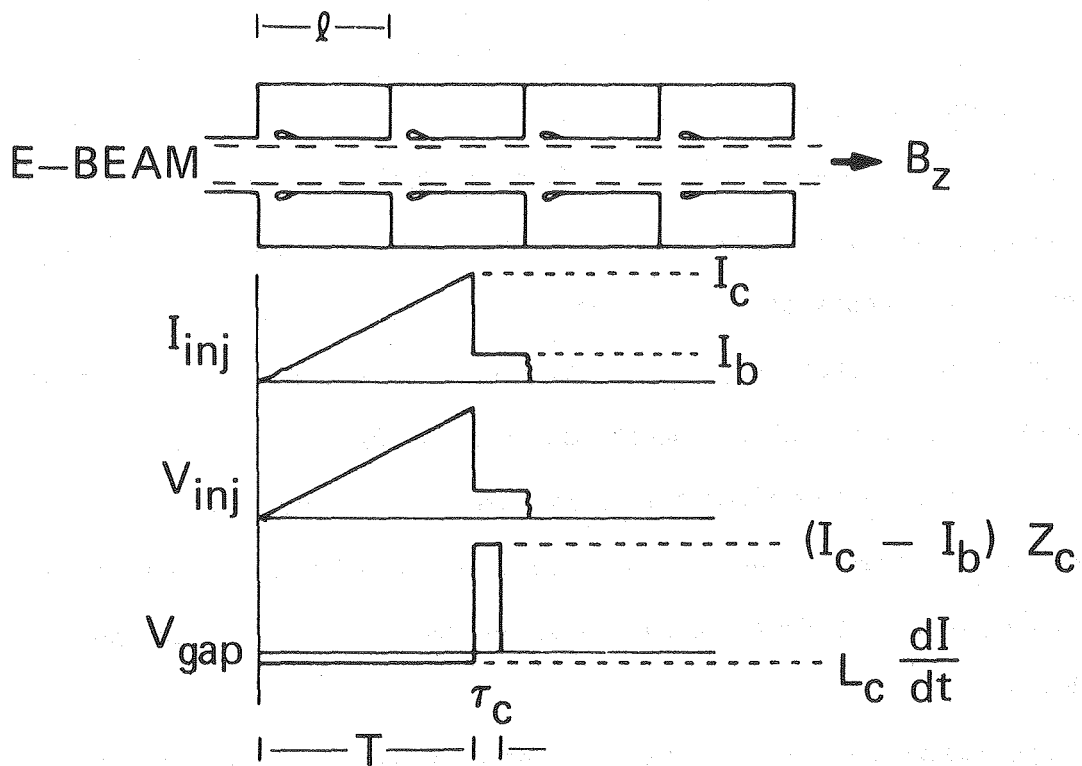

$T = \text{CURRENT RISE TIME} = 800 \text{ ns}$

$$\tau_c = \frac{2l}{c} = 6 \text{ ns}$$

$Z_c = \text{CAVITY IMPEDANCE} = 70 \Omega$

$L_c = \text{CAVITY INDUCTANCE} = 0.23 \mu\text{H}$

XBL 812-8203

Fig. 4

If the current rise is halted at $i(t) = I$ and the electron-beam current returned to zero, the destructive reflections that keep the gap voltage at this low value are suddenly removed and it can quickly be verified that a large accelerating voltage, $Z_0 I$, appears on the gap for a time 2τ . In the NRL auto-accelerator the electron-beam current is switched not to zero but to $I/5$, so that the accelerating voltage per gap is $0.8 Z_0 I$. (See Fig. 4).

What is distinctive about this device is that it circumvents two of the major problems of pulse-power accelerators--the switches and the insulators. Since the magnetic energy release from a cavity begins just when the downward step in beam-current occurs at the gap location, the accelerator is automatically self-synchronized from gap to gap; jitter is eliminated because switches are not needed. Insulators at the acceleration gaps are also not required; for short pulses, very high voltages (~ 3 MV) can be achieved across just a few centimeters in vacuum. Finally, the accelerator can be designed to have relatively high efficiency from the wall plug to the beam, perhaps in the region of 30%.

In the experiments now in progress, the injector is an E-beam generator, with a transmission line for pulse forming, which produces a 30 kA, 1.5 MeV, hollow beam from a foiless diode. This beam is transported in a uniform-field solenoid magnet (15 kG) through a sequence of coaxial cavities. Six cavities are planned for the proof-of-principle experiment; as of 1980 two had been installed and successfully tested. Electrons were accelerated from 0.3 MV to 3 MV with 4 kA beam current. Some "cross-talk" was encountered between the two cavities, but it was eliminated by reducing the Q-factor of the cavities.

It is tempting to call this device a collective accelerator in which electrons are used to accelerate other electrons, but it does not comply with the

spirit of the definitions in the Introduction in that the electromagnetic field occurs as an intermediary between the action of one set of electrons and the reaction of the other set. (Note, for comparison, that in a conventional rf accelerator electron-beam tubes create rf fields that are coupled via wires or waveguides to cavities and thence to the beam).

III. CATEGORY 2: COLLECTIVE DEVICES AND CONCEPTS

III.1 Collective Effects for Transverse Focusing:

Some examples of proven utility: The transport of an ion beam from the ion-source to the Cockcroft-Walton column in a standard accelerator preinjector poses serious problems for very high intensities and for heavier ions; these arise from limitations on the strength of magnetic lenses. Several examples are now known (e.g. 60 mA Xe source at LBL,¹⁶ 150 mA Deuteron RTNS at LLL¹⁷) where a suitably "gassy" condition of the transport line can be arranged so that ionization is caused by the head of the beam, the cold ions drift to the walls of the beam-pipe, and the electrons remain held in the space charge potential of the following parts of the beam. One can speak of "neutralization" of the self-field of the ion beam but in the spirit of the earlier definition in Eq. (2), the trapped electrons form a collective distributed focusing lens. Instabilities can occur if there is noise in the plasma source with a period close to the ionization time or the cold-ion drift time. Nonetheless, totally stable operation is easily achieved in which the electrons are relied upon to do as much as 97% of the focusing. For short pulses of heavy ions, electron focusing has also been achieved at LBL by arranging for the injection of electrons from a grid; time dependent effects are still unexplored.

The inverse situation has also been observed for electron beams when some gas is present; here the cold ions remain for focusing and the cold electrons are expelled. Stable operation under these conditions has, for example, occurred in experiments on the propagation of intense electron beams at Livermore¹⁸ and at NBS.¹² A more complicated collective mechanism enters into the stable propagation in the ballistic mode of high-current ion beams. Here the beam must be both charge-neutralized and current-neutralized. Thus not alone does the equation, $\text{Div } \underline{E} \neq 0$, hold but also $\text{Curl } \underline{B} \neq 0$ if we treat that part due to the plasma current and ignore the beam. Again, instabilities (e.g., kink modes) can occur, but there is a window of stability.

When an ion or electron lens created by neutralization is used as a major contributor to the focusing, it is usual that the beam charge density and cold ion/electron density are close to being equal. An example, however, of a very useful collective lens in which the electron density greatly exceeds the beam ion density is due to Gabor.¹⁹ The electrons are trapped in a cylinder with an axial magnetic field and with electrostatic reflectors at the ends. In the steady state, the surface of a magnetic flux-tube concentric with the axis is an electrical equipotential, and an important feature is the possibility of controlling the value of these potentials (and hence the aberrations) by properly biasing boundary rings through which the flux-surfaces pass.²⁰ Electrons can either be injected from a filament or else created by ionization of some injected gas. In experiments at Brookhaven the lens behavior was found to be remarkably linear.²¹

Magnetically-Insulated Electron-Focussed Ion Linac (PULSELAC): Results to date from this program are very promising. The basic acceleration scheme is a conventional one using pulsed drift tubes to accelerate a long slug of

ions.^{22,23} Ions are accelerated into a drift tube and when the head of the beam reaches the downstream end the voltage is removed from the drift tube and the succeeding one switched on. Instead of using conventional focusing, Humphries et al. have arranged to inject electrons into the drift tubes to provide transverse focusing of the ion beam; a convenient arrangement is an array of field emission points. The key feature of the scheme, however, is to prevent the electrons from crossing the accelerating gap between successive drift tubes so that they do not constitute an inordinate current drain on the power supply. This is accomplished by magnetic insulation whereby a magnetic field is applied in such a direction that the electrons perform magnetron orbits (with an $\vec{E} \times \vec{B}$ drift) but can never cross the gap and so drain the voltage generator. Obviously, fresh electrons must be injected into successive drift tubes.

Creating such a situation requires the drift tube to consist of two concentric tubes with an annular ion-beam contained between them (Fig. 5). Conductors wound around the outer radius at the tips of the outer tube, and around the inner radius of the inner tube can provide a magnetic field to meet the requirement of magnetic insulation. A useful feature of this arrangement is that the $\vec{E} \times \vec{B}$ drift can carry the electrons around the axis again and again; thus charge-accumulation, which can be troublesome in other geometries, is avoided.

A set of plasma guns arranged in an annulus supplies about 3,000 to 4,000 Amps of carbon ions for injection; a 5-gap pulsed drift-tube system now in operation produces at its exit an impressive 3,000 Amps of carbon ions at an energy of 600 keV, with good emittance. These results seem to indicate that the mobile electron species can adjust its distribution in a benign way to

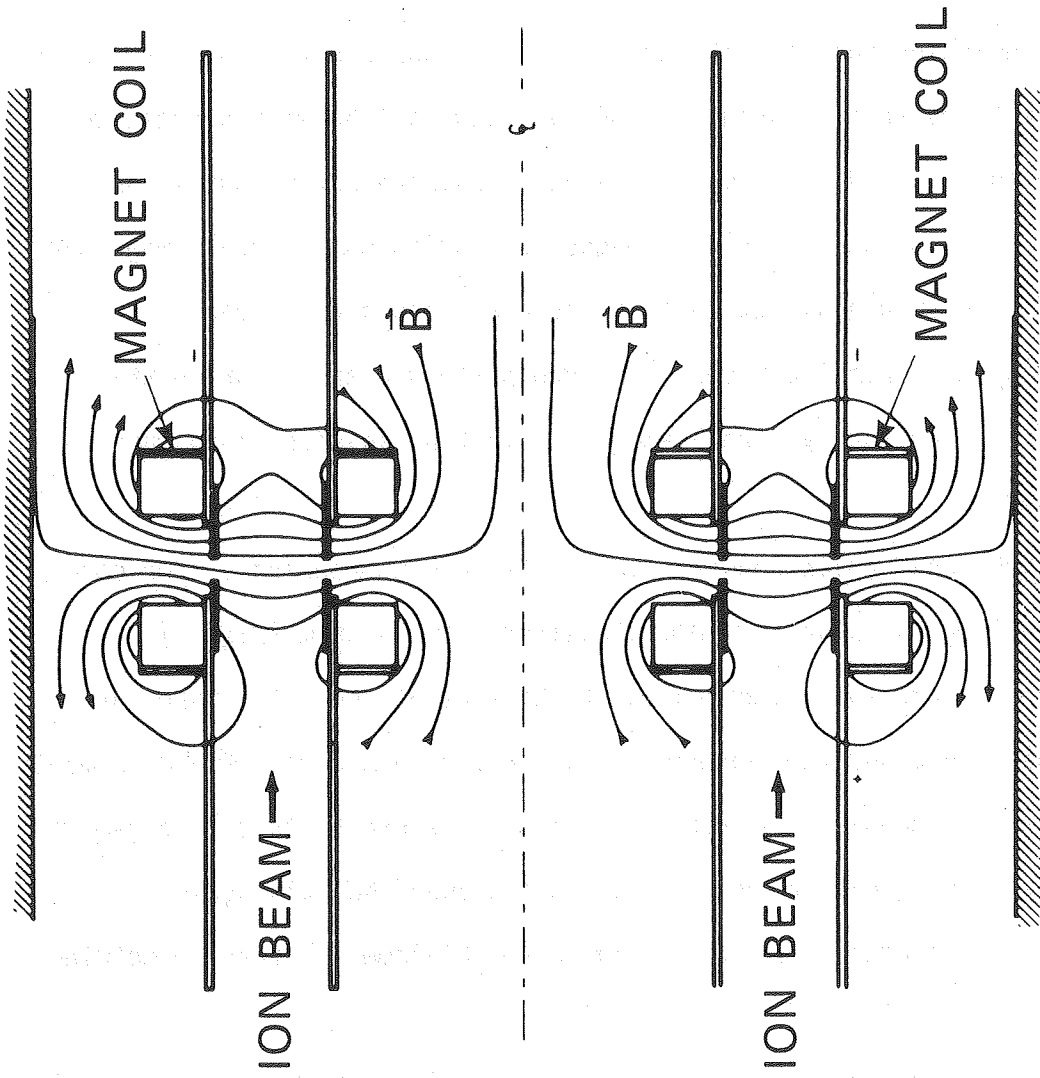

XBL 812-8198

Fig. 5(a)

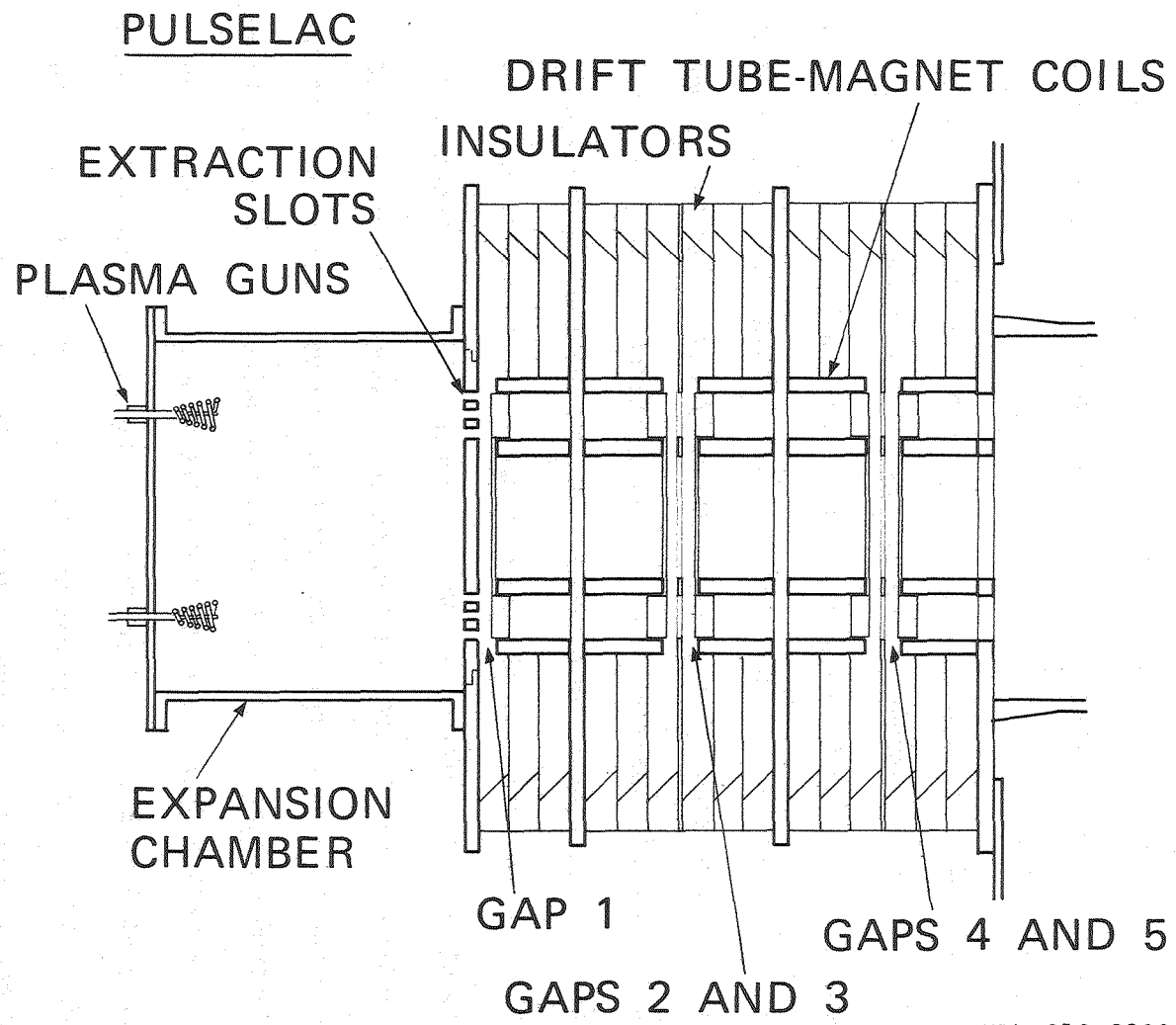

XBL 812-8200

Fig. 5 (b)

provide focusing that is both strong and, as far as one can judge, reasonably linear.

Toroidal Electron Focused Ion Accelerator. This concept proposed by Irani and Rostoker,²⁴ is closely related to an early proposal (1956) by Budker²⁵ to use an intense beam of electrons to provide a strong guide field for protons in a circular accelerator. Several novel features are included, however, that make the idea seem attractive. The basic idea is to create a bumpy toroidal magnetic field, i.e., a string of mirrors that closes on itself, and to inject an intense cloud of electrons with predominantly transverse velocities (i.e., no toroidal component). The electrons form a deep potential well into which ions are injected; the ions are then accelerated by pulsing a transformer exactly as in a betatron. A design has been proposed by Maxwell Labs that would operate with transverse collective focusing fields of 10 MV/cm and would accelerate an extremely intense proton beam to 2.6 GeV.²⁶

The key to the operation is the local trapping of the electrons in the multiplicity of mirrors. When the induced electric field is created, essentially no electrons are accelerated because the loss-cone is unpopulated. This has been verified in a small experiment at Irvine. Suppression of the toroidal electron current is essential to avoid taking all the energy from the generator. The design draws heavily on results from an early collective device (HIPAC) at Avco Everett in which the technique for injection of electrons with high transverse energy was developed.²⁷ In addition, work on HIPAC succeeded in mapping out the regions of potential instabilities (diocotron, magnetron, ion-resonance) and, as a result of that work, the proposed design pays careful attention to avoiding these hazards.

A table-top experiment is underway to demonstrate proton acceleration to a few MeV. The electron guiding field will be about 1 cm in minor and 1 m in major diameter. So far, collective focusing fields of 500 kV/cm have been achieved. Also of interest in this program is a proposal to use a plasma gun as a collective effect extraction system.

Rostoker has also proposed that a pulsed toroidal field might be used at injection into a betatron to achieve extremely high-current electron beams.²⁸

III.2. Collective Effects for Longitudinal Acceleration

Electron Cluster Containing Ions (ERA): This concept aims to accelerate an intense cluster of electrons that contains, captured in its electrostatic well, a relatively small number of ions. The lighter electrons respond rapidly to an external accelerating electric field and the protons - going along for the ride, as it were - thus gain energy at a rate that is enhanced by the very large factor of the proton-to-electron mass ratio (1836 times). Since it is essential to maintain the stability of the electron cluster, Veksler proposed the creation of a relativistic electron ring which, indeed, can be stabilized.²⁹ Relativistic effects for this configuration reduced the energy enhancement factor to about 40; even so, this would still be an exciting gain if achieved.³⁰

The development of an ERA has been actively pursued at Dubna for more than a decade.³¹ Elsewhere, an extensive series of measurements has been carried out at LBL, MPIPP (Garching) and Maryland, and a variety of instability limits (resistive-wall, negative mass, ion-resonance) identified.³² The potential peak accelerating rate was determined to be no more than 80 MeV/m. This work

is no longer pursued in the U.S. or Germany, although a large group is continuing with their program at Dubna. The Russian group has regularly accelerated protons to a few MeV and Xenon ions to over 300 MeV.

Moving Potential Well: There is a long list of experiments in this category that have successfully produced large intensities of accelerated protons and other ions.³³ The highest fluxes of protons usually are concentrated at a kinetic energy of about three times the electron beam energy, although a few mechanisms have been found to give much higher energies (> 60 MeV). These experiments all employ E-beam technology in which a generator – typically a Marx generator charging a coaxial or Blumlein line – is connected to a pulsed E-beam diode. Fairly common parameters for the electron beams are

Energy: 1 – 10 MeV

Current: 10 – 100 kA

Pulse length: a few x 100 nsec.

The electron beam passes through the anode foil and enters a drift pipe which is usually (but not always) surrounded by a solenoid to provide a transverse focusing field.

Most of these experiments rely on creating a virtual cathode within the drift pipe and arranging for it or the head of the beam to move relatively slowly down the pipe. Background ions from the walls or a gas are accelerated by this moving potential well typically to speeds of $\beta \approx 0.1$. Some experiments rely on controlling a potential well by external means.

A virtual cathode will form in a metal pipe just downstream of the anode foil if the injected beam current exceeds the so-called "limiting current"

I_L given by

$$I_L = \left(\frac{mc^3}{e}\right) \frac{(\gamma^{2/3} - 1)^{3/2}}{(1+2 \ln a/b)(1-f_e)} \quad (3)$$

(this expression requires some modification if a dielectric wall is also present), where

$$mc^3/e = 17,000 \text{ Amps}$$

γ = total energy/rest energy

a = pipe radius

b = beam radius

f_e = fractional neutralization

= ion density/electron density.

Another critical current of interest is the Alfven-Lawson limit

$$I_Z = \frac{mc^3}{e} \beta \gamma, \quad (4)$$

which is usually significantly larger than I_L .

The trick that is used is to arrange the initial parameters on the right-hand side of Eq. (2) such that the limiting current is below the injected E-beam current to guarantee formation of a virtual cathode by the entering portion of the beam. Next one arranges to vary one or more of the parameters in Eq. (3) to bring I_L up to the beam current and so attain propagation; if this can take place slowly enough, at first, background ions are trapped and accelerated. For example:

- . γ can be varied with time by having a ramp on the diode voltage
- . (a/b) can be varied along the pipe by changing the pipe radius, or by changing the beam size (tapered magnetic field).
- . the fractional neutralization f_e will vary in time because ions are continually being created from the background gas or from beam bombardment of the walls. It will also vary with distance as the beam propagates and can additionally be controlled by a density gradient in the gas, or by injection of outside ions. Thus it is clearly possible to create a deep potential well (>1 MV), have it start slowly, and have some measure of control over how its speed changes in passing down the pipe.

The general features of this acceleration mechanism--first discovered by Graybill and Uglum³⁴ in 1968--were elucidated in experiments at Physics International,³⁵ Air Force Weapons Laboratory,³⁶ Sandia³⁷ and Irvine.³⁸ More recent work with gas gradients has been done at Irvine.³⁹ Experiments with dielectric-walled drift pipes in which electrons escaping laterally from the virtual anode cause ions to be knocked out from the dielectric as it progresses down the pipe have been done by Greenwald and Little⁴⁰ and by Pasour et al.⁴¹ Generally, these experiments led to intense fluxes of protons with an energy about three times that of the electrons, although somewhat higher energies were achieved at Physics International and AFWL with beams approaching the Alfvén limit.^{42,43}

Much higher energy protons have been produced in a system developed by Luce.⁴⁴ Here the anode is an insulator having an on-axis hole (Fig. 6). Although the mechanism is not well understood, it appears that a virtual

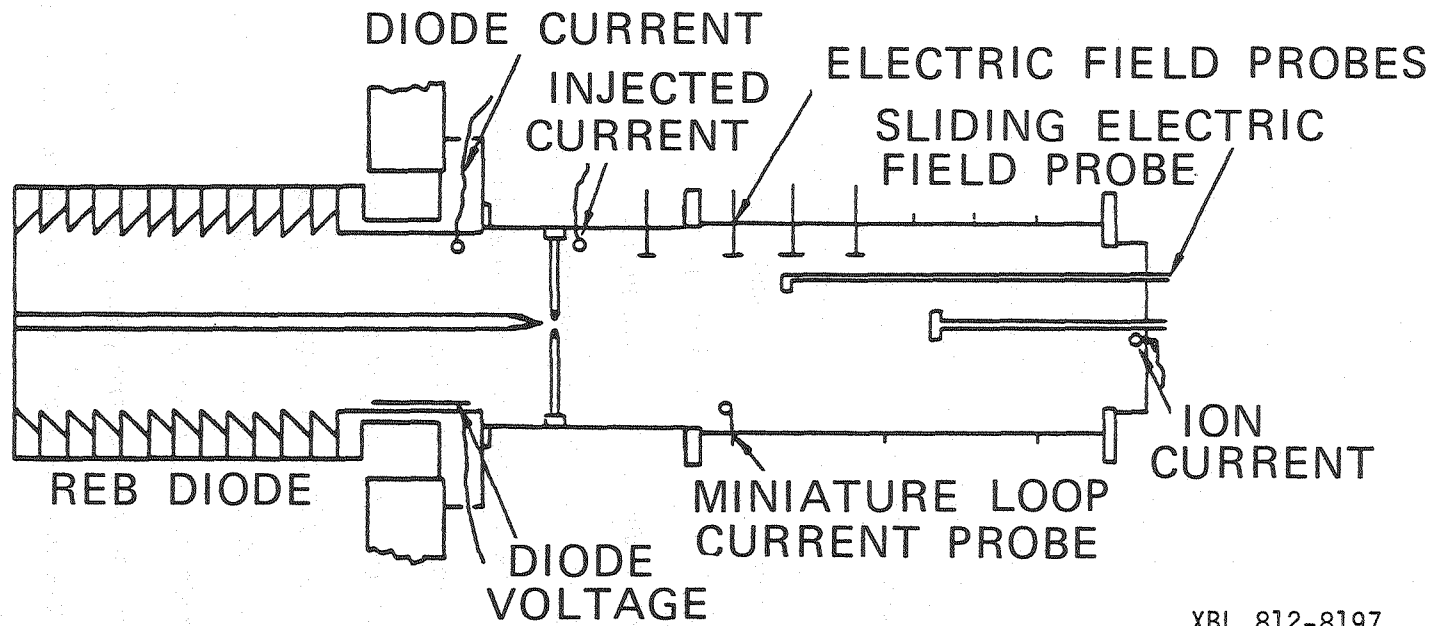

XBL 812-8197

Fig. 6

cathode is formed downstream of the anode, and electron bombardment causes flash-over of the insulator, thus liberating ions that are accelerated to the virtual cathode and may pass through it to form a virtual anode. This in turn attracts the electrons and a bootstrap action persists for some distance. Proton energies up to 60 MeV have been observed. Energetic proton beams from vacuum diodes have been widely observed, e.g., at Maryland,⁴⁵ Cornell,⁴⁶ AFWL,⁴⁷ and Boeing.⁴⁸ At the last institution, Adamski has proposed a scheme in which the Luce diode can be extended to at first two and, later, several stages to obtain still higher energies.

Three schemes are under study in which a potential well is propagated at a programmed and increasing velocity by means of externally controlled elements. Rostoker⁴⁹ proposes to inject ions from a pulsed wall plasma to speed up the virtual cathode in a time-programmed manner. With the present equipment he hopes to achieve 10 MeV protons and feels it can be extended to 100 MeV. In the Ionization Front Accelerator (IFA), under study by Olson,⁵⁰ the electron beam is injected above the limiting current into a tube containing a low-pressure working gas, which has been chosen to be cesium vapor (Fig. 7). The pressure is low enough that for the duration of the beam pulse there is not enough ionization to allow the beam current to become less than the limiting current and so to propagate quickly. Arranged along the side of the tube are a series of light pipes through which carefully timed pulses of laser light can enter to ionize the cesium. Enough ions are produced upstream of the virtual cathode at the head of the beam to neutralize the beam space charge in that region and reduce the potential to zero. Downstream of the beam head there is little beam present and the potential is also essentially zero there. Thus the potential well in the beam head provides an

accelerating bucket that in fact has quite a sharp gradient at the upstream side. By gradually advancing the region of ion creation by successive laser light pulses, the well can be nudged forward at a predetermined rate to accelerate ions. In an initial set of experiments, the controlled beam front motion has been demonstrated. By introducing some hydrogen gas and setting the sweep-rate of the beam front, Olson has observed proton acceleration; the data suggest that controlled accelerating fields of 50 MV/m have been achieved.

Because it is unusual in having several features externally controllable, the Collective Particle Accelerator (CPA), now under test by Friedman at NRL, is an especially interesting concept.⁵¹ In this, a hollow electron beam is injected below the limiting current, passed through a chopper to create a sequence of rings of charge which then enter a guide field made up of discrete short solenoids. As the train of rings passes down the rippled guide-field, their radii throb alternately inward and outward. This produces an axial electric accelerating field which can be decomposed into two waves, a slow forward wave ($v < c$) and a backward wave that can be either slow or fast, depending on the choice of parameters. The phase velocity of the accelerating wave can be controlled by varying either the inter-ring spacing or the inter-magnet spacing and its amplitude can be varied by changing either the beam current or the magnetic field strength. Note that the mechanism proceeds by the action of discrete rings of charge, each of which retains its identity, and thus is quite different from the wave accelerators discussed below. It is clear that the electron rings act also to produce radial focusing of the ions. For experimental convenience, the present tests at NRL are aimed at using the backward wave to demonstrate ion acceleration. In practice, the forward wave would seem to be easier to control.

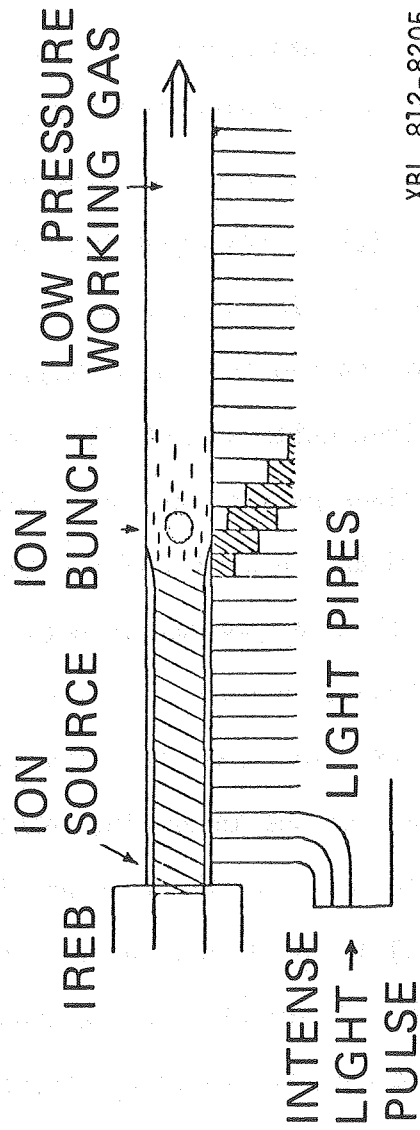

XBL 812-8205

Fig. 7

Experiments have proceeded to the point of generating a train of discrete rings and propagating them along the bumpy solenoid guide field for a distance of several meters.

III.3 Acceleration by Waves on Intense Relativistic Electron Beams

Another technique for the controlled collective acceleration of protons uses a negative-energy wave train grown on an electron beam propagating in a vacuum and confined by an axial magnetic field. There are two experiments in progress for a few years to study the potential for application of variable phase-velocity wave trains to collective acceleration. Both have recently succeeded in demonstrating the excitation and growth of the wanted waves and the suppression of other unwanted modes, but have not yet reached the point of injecting and accelerating ions. Although each of these experiments utilizes waves of very different character - one a cyclotron wave, the other a space-charge wave - both have the feature of exploiting a negative energy mode. Thus, the greater the number of ions accelerated the larger the amplitude of the accelerating field grows (until nonlinear saturation occurs). Large-amplitude wave excitation creates a longitudinal modulation of the space-charge potential and, hence, a sequence of accelerating buckets that propagate along the beam with the phase velocity of the wave. Acceleration of the ions is achieved by arranging for the phase velocity to increase from some initially low value at injection.

Auto Resonant Accelerator: This system utilizes a cyclotron wave (so-called lower-hybrid Doppler-shifted cyclotron mode) which has the attractive feature that the phase velocity can be made very small; thus ions can be picked up from rest by simply injecting a puff of gas at the appropriate place.⁵² The phase velocity of this wave is given by:

$$v_{pj} = v_e \left(1 + \frac{eB}{mc\omega_0\gamma} \right)^{-1} \quad (5)$$

where the electron velocity v_e is close to the speed of light, $eB/mc\gamma = \Omega$ is the cyclotron frequency, and ω_0 is the angular frequency chosen for exciting the wave. By choosing a high field (high Ω) and relatively low frequency ω_0 the phase velocity can be made initially small ($\ll c$) for ion pickup.

Thereafter the magnetic field can be diminished in a tapered way, the phase velocity increased and the ions accelerated.

A proof-of-principle experiment is underway at Austin following extensive theoretical analysis (Fig. 8). The procedure is to pass the beam (2.5 MV, 20 kA) through a double-helical resonant excitation section driven at $\omega_0/2\pi = 250$ MHz to excite the wave. Next comes a dissipative helical growth section which loads the wave and thereby causes it to increase in amplitude. This has now been accomplished (and incipient non-axisymmetric modes suppressed) and potential wells of about 200 kV demonstrated, in modest magnetic fields (~ 2 kG).⁵³ Because the phase velocity is not small, the next step will be to pass the beam into a tapered solenoid (from 2 kG up to 20 kG) to slow down the wave to the point where ion pickup is possible. Finally the flared-field accelerating section will be added.

Space-charge Wave Accelerator: The second wave system being studied for acceleration employs a negative-energy slow space-charge wave grown on the beam during its propagation through a slow-wave excitation structure. The behavior of slow space-charge waves has been long studied in the case of vacuum tubes but there are some differences for relativistic high-current beams. The expression for the phase-velocity bears a formal resemblance to Eq.(5), viz.

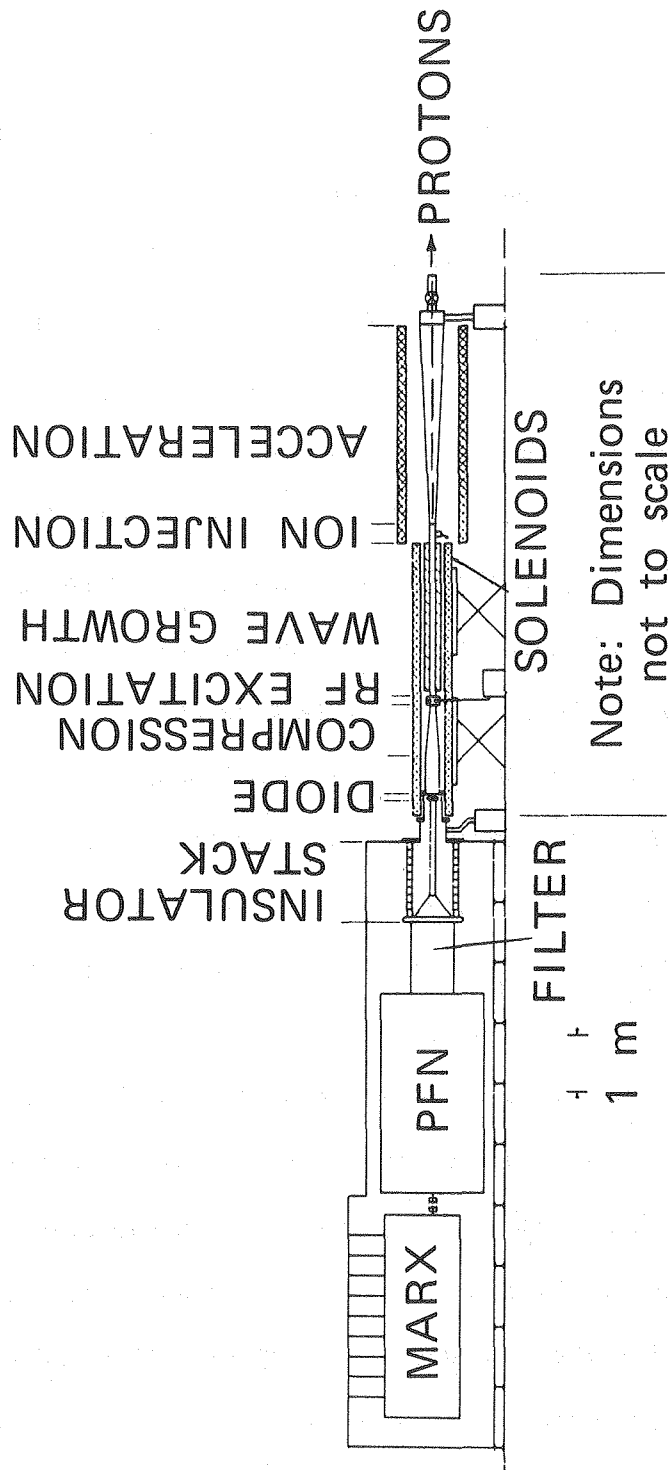

Fig. 8

$$v_{ph} = v_e \left(1 + F + \frac{\omega_p}{\omega_0} \right)^{-1} \quad (6)$$

where ω_0 is the impressed frequency; ω_p is the beam plasma frequency (relativistic) and F is a plasma frequency reduction factor that depends on the ratio of the beam diameter to pipe diameter.

It was pointed out by Sprangle et al. at NRL⁵⁴ that an accelerator could be built by injecting a beam of constant diameter into a pipe whose walls converged in tapered fashion towards the beam (Convergent Guide Accelerator, or CGA). Under such a circumstance $F\omega_p$ can be made to decrease with distance in a programmed way and, accordingly, the phase velocity v_{ph} increased gradually as needed. Sprangle et al. gave arguments showing that such an accelerator could give 0.5 Amps of protons at 300 MeV in a length of 15 m.

Upon analysis, however, it turns out that one cannot practically realize low values for v_{ph} , in contrast with the cyclotron wave case. As v_{ph} tends to zero, the beam current I approaches the limiting current I_L of Eq. (3). For this reason, values of v_{ph} below 0.2 c seem impracticable; such an accelerator will thus require an ion injector.

Experiments by Nation at Cornell in the last two years with a 250 kV beam have shown successful growth of a slow wave in an iris-loaded structure at $\omega_0/2\pi = 1.1$ GHz.⁵⁵ The growth was rapid (5 db/iris) and accelerating fields of 6 MV/m were generated. In order to study low phase velocities, he used a flared beam pipe to slow down the wave (the opposite of the CGA) and found that below $v_{ph} = 0.2$ c , operation was so close to the limiting current that the system was grossly erratic. At this time he is ready to inject protons at ~ 20 MeV into the wave from an induction linac in order to study trapping and acceleration.⁵⁶

IV. SUMMARY AND CONCLUSIONS

Although there is obviously much more work to be done in the areas of accelerator research and development discussed above, there has nonetheless been very significant progress in the last few years in understanding and developing high-current accelerators and collective effect devices. Among the more important advances one can list the following:

- . A new level of sophistication has been introduced into the diagnosis of emittance behavior in conventional proton rf linacs;
- . The frontiers of beam current and energy are being advanced for the electron induction linac. For years the induction linac has been a high repetition-rate pulse power device in the 1 kA, 5 MeV range. Now the beam current is an order of magnitude greater and soon the energy will be increased by a like factor;
- . In the electron beam current range of 100 kA, the energy frontier is also being advanced by exploration of multiply staged pulse-power accelerating modules such as in the RADLAC and the autoaccelerator.
- . Although still far from complete, understanding of neutralization techniques for providing strong transverse focusing for intense beams has advanced considerably (e.g., in the Pulselac and Toroidal Ion Accelerator experiments). Such techniques will undoubtedly provide a valuable future tool in accelerator technology.
- . A new generation of experiments has begun in collective acceleration of ions. The generation of high fluxes of low energy ions by electron beams in gas cells and related devices is rather well understood and is of limited application. The accent now is on devices that can be scaled

to higher ion energy. These include multiply-staged devices such as cascaded Luce diodes, wave accelerators (e.g., ARA, NRL, and Cornell) and externally controlled moving potential wells (e.g., IFA, and CPA).

The broad goals of most of the accelerator research and development addressed in this report have been two fold: the advancement of high-current relativistic electron-beam technology and the acceleration of ions from low energy. The latter is an especially difficult problem because of the need to control collective fields that move very slowly initially and can be later speeded up in a programmed fashion. This is a complicated research field still in an emergent stage; which effects and devices will pay off in the future, what their unique advantages may be, or what things are still undiscovered, are all unanswered questions.

V. ACKNOWLEDGMENTS

My thanks are due to Dr. George Gillespie for his helpful comments and advice.

VI. REFERENCES

General:

- A. C. L. Olson and U. Schumacher, Collective Ion Acceleration (Springer Verlag, Berlin, 1979) by
- B. Collective Methods of Acceleration (Harwood, New York, 1979) edited by N. Rostoker and M. Reiser.
- C. J. Nation, Particle Accelerators, 10, 1 (1979).

Specific:

1. See, for instance, "Report of the Subpanel on Accelerator Research and Development of the High Energy Physics Advisory Panel", M. Tigner, R. Diebold, K. Johnsen, D. Keefe, A. McInturff, F. Mills, W. Panofsky, C. Pellegrini, J. Sandweiss, R. Schwitters, L. Teng, A. Tollestrup, and W. Willis. DOE/ER-006, (June 1980).
2. See, for instance, the Proceedings of the Heavy Ion Fusion Workshops:
Lawrence Berkeley Laboratory Report: LBL-5543 (1976)
Brookhaven National Laboratory Report: BNL-50769 (1978)
Argonne National Laboratory Report: ANL-79-41 (1979)
Lawrence Berkeley Laboratory Report: LBL-10301 (1980)

3. P. W. Allison, Proceedings of the Symposium on the Production and Neutralization of Negative Hydrogen Ions and Beams, Brookhaven National Laboratory, Sept. 26-30, 1977, BNL-50727, 119 (1978).
4. J. P. Aldridge and T. D. Hayward, Proc. 8th IEEE Symp. on Eng. Problems in Fusion Research, (San Francisco), 1, 479 (1979).
5. I. M. Kapchinskij and V. A. Teplyakov, Prib. Tekh. Eksp., 2, 19 (1970).
6. K. Halbach, IEEE Trans. Nucl. Sci., NS-26, 3882 (1979).
7. SLAC Linear Collider Conceptual Design Report, SLAC-Report-229, 35 (June 1980).
8. See, for instance, J. Leiss, IEEE Trans. Nucl. Sci., NS-26, 3870 (1979).
9. R. Briggs, Proc. 1981 Particle Accel. Conf., to be published in IEEE Trans. Nuc. Sci., NS-28 (June 1981).
10. T. Fessenden, W. Atchison, D. Birx, R. Hester, K. Struve, and D. Rogers, ibid.
11. R. E. Hester, D. G. Bupp, J. C. Clark, A. W. Chesterman, E. G. Cook, W. L. Dexter, T. J. Fessenden, L. L. Reginato, T. T. Yokota, and A. Faltens, IEEE Trans. Nucl. Sci., NS-26, 4180 (1979).
12. J. Leiss, N. Norris and M. Wilson, Particle Accelerators 10, 223 (1980).
13. A. I. Pavlovskij, Sov. Phys. Dokl., 20, 441 (1975).
14. R. B. Miller, K. R. Prestwich, J. W. Poukey, B. G. Epstein, J. R. Freeman, A. W. Sharpe, W. R. Tucker and S. L. Slope, Jour. App. Phys. (to be published March, 1981).

15. T. R. Lockner and M. Friedman, IEEE Trans. Nucl. Sci. NS-26, 4237 (1979).
16. W. Chupp, D. Clark, R. Richter, J. Staples, and E. Zajec, IEEE Trans. Nucl. Sci. NS-26, 3036 (1979).
17. J. E. Osher and J. C. Davis, Proc. 1976 Proton Linear Accelerator Conf., Chalk River, AECL-5677, 316 (1976).
18. R. J. Briggs, J. C. Clark, T. J. Fessenden, R. E. Hester and E. J. Lauer, Proc. 2nd Int. Top. Conf. on High-Power Electron and Ion Beam Res. and Techn. (LPS Cornell Univ.) I, 319 (1977).
19. D. Gabor, Nature 160, 89 (1947).
20. R. Booth and H. W. Lefevre, Nucl. Instrum. Methods 151, 143 (1978).
21. R. M. Mobley, G. Gammel, and A. W. Maschke, IEEE Trans. Nucl. Sci. NS-26, 3112 (1979).
22. A. Faltens and D. Keefe, Particle Accelerators 8, 245 (1978).
23. S. Humphries, J. R. Freeman, J. Greenly, G. W. Kuswa, C. W. Mendel, J. W. Poukey and D. W. Woodall, IEEE Trans. Nucl. Sci. NS-26, 4220 (1979).
24. A. Irani and N. Rostoker, Particle Accelerators 8, 107 (1978).
25. G.I. Budker, Proc. CERN Symp. High-Energy Accel., Geneva (CERN, Geneva, 1956), I, p.68.
26. A. A. Mondelli and N. Rostoker, Reference B (above), p. 611 (1979).
27. J. D. Daugherty, J. E. Eninger, G. S. Janes and R. H. Levy, Proc. 1st Int. Conf. Ion Sources (Saclay), 643 (1969).
28. N. Rostoker, Particle Accelerators 5, 93 (1973).
29. V. I. Veksler, Proc. CERN Symp. on High-Energy Accelerators Geneva, I, 80 (1956).

30. See, for instance, D. Keefe, Particle Accelerators 1, 1 (1970)
31. V. I. Veksler et al., Proc. Vth Int. Conf. on High-Energy Accelerators, (Cambridge Electron Accelerator Report No. CEAL-2000), 289 (1967).
32. See U. Schumacher, in Reference A, for numerous references.
33. See C. Olson, in Reference A, for extensive references.
34. S. E. Graybill and J. R. Uglum, J. Appl. Phys. 41, 236 (1970).
35. J. Rander, B. Ecker, G. Yonas and D. J. Drickey, Phys. Rev. Lett. 24, 283 (1970).
36. R. B. Miller and D. C. Straw, J. Appl. Phys. 47, 1897, (1976) also ibid., p. 4681.
37. G. W. Kuswa, L. P. Bradley, and G. Yonas, IEEE Trans. Nucl. Sci. NS-20, 305 (1973).
38. C. W. Roberson, S. Eckhouse, A. Fisher, S. Robertson and N. Rostoker, Phys. Rev. Lett. 36, 1457 (1976).
39. F. Mako, A. Fisher, N. Rostoker, D. Tzach, and C. W. Roberson, IEEE Trans. Nucl. Sci. NS-26, 4199 (1979).
40. A. Greenwald and R. Little, Proc. 2nd Int. Top. Conf. High Power Electron and Ion Beam Research and Technology (LPS, Cornell Univ. 1978) p. 553.
41. J. A. Pasour, R. K. Parker, W. O. Doggett, D. Pershing, and R. L. Gullickson, ibid., 623.
42. B. Ecker and S. Putnam, IEEE Trans. Nucl. Sci. NS-24, 1665 (1977).
43. R. B. Miller and D. C. Straw, Proc. Int. Top. Conf. on Electron Beam Res. and Techn. (Albuquerque 1975), Sandia Lab. Report No. SAND 76-5122, 368 (1976).

44. J. S. Luce, H. L. Sahlin and T. R. Crites, IEEE Trans. Nucl. Sci. NS-20, 336 (1973).
45. W. W. Destler and H. Kim, Proc. 2nd Int. Top. Conf. on High-Power Electron and Ion Beam Res. and Techn. (Cornell 1977) Cornell Univ. L.P.S., 521 (1977).
46. R. J. Adler, G. Gammel, J. A. Nation, J. D. Ivers, G. Providakes, V. Serlin, IEEE Trans. Nuc. Sci. NS-26, 4223 (1979).
47. R. F. Hoberling, in Reference B, 463 (1978).
48. J. L. Adamski, P. S. P. Wei, J. R. Beymer, R. L. Guay, and R. L. Copeland, ibid., 497 (1977).
49. N. Rostoker, (private communication, 1980).
50. C. L. Olson, IEEE Trans. Nucl. Sci. NS-26, 4231 (1979).
51. M. Friedman, IEEE Trans. Nucl. Sci., NS-26, 4186 (1979).
52. M. L. Sloan and W. B. Drummond, Phys. Rev. Letters 31, 1234-1237 (1973).
53. H. A. Davis, E. Cornet, W. W. Rienstra, and T. P. Starke, Bull. Am. Phys. Soc. 25, 839 (1980).
54. P. Sprangle, A. T. Drobot and W. M. Manheimer, Phys. Rev. Lett. 36, 1180 (1976).
55. R. Adler, G. Gammel, J. A. Nation, G. Providakes and R. Williams, Rev. B, 249 (1978).
56. J. A. Nation, D. Aster and J. Ivers, Bull. Am. Phys. Soc. 25, 945 (1980).

FIGURES CAPTIONS

Figure 1: Schematic diagram of experimental apparatus for measurement of phase space volume.

Figure 2: Evolution of the induction linac geometry. In (a) it can be seen that a shorted transmission line with a hollow center conductor can accelerate particles across the gap shown; the voltage disappears, however, when the inverted reflection returns from the shorted end to the gap. For pulses much longer than a few nanoseconds this would provide a very low accelerating gradient. In (b) ferromagnetic material increases the electrical line length and thus allows long pulse length without sacrificing gradient. Several cores driven in parallel can provide increased gap voltage; they may be stacked axially (c) or radially (d). The latter was the choice for the NBS 2 μ sec induction linac.

Figure 3: The RADLAC comprises four folded radial pulse lines that are filled with oil. The taper is chosen to provide constant characteristic impedance in the radial direction. The 2 MeV injector is an E-beam generator and diode.

Figure 4: The NRL autoaccelerator concept. From top to bottom the figures show: Cavity structure; injected current $i(t)$; voltage developed across each gap showing the time averaged retarding voltage $L_c di/dt$ during the current rise, and the accelerating voltage during the current drop.

Figure 5(a): The arrangement of the four field coils to produce the desired magnetic field in an accelerating gap of the Pulselac. Note that the ions form a hollow cylindrical beam situated in the space between the two coaxial conductors that make up a drift tube.

Figure 5(b): A schematic of the Pulselac that shows the three pulsed drift tubes and the annular carbon ion source.

Figure 6: Schematic of a Luce diode in a form used at Boeing. The pointed cathode is pulsed to high voltage by a pulse power E-beam generator. Monitoring and diagnostic probes are labeled.

Figure 7: Schematic of the Ionization Front Accelerator (IFA). The beam behind the beam front has been charge-neutralized by earlier laser-ionization of the working gas; ahead of the front no significant amount of beam is present. Thus the beam-front forms a deep potential bucket that can be edged forward at a controlled rate by laser-ionization at its rear end.

Figure 8: Schematic of the auto-resonant accelerator (ARA). In recent experiments, the resistive liner wave growth section has been placed upstream of the beam compression section rather than downstream.