

# Lawrence Berkeley National Laboratory

## LBL Publications

### **Title**

Physics With and Physics of Colliding Electron Beams

### **Permalink**

<https://escholarship.org/uc/item/304035g7>

### **Authors**

Pellegrini, Claudio

Sessler, Andrew M

### **Publication Date**

1969-11-01

PHYSICS WITH AND PHYSICS OF COLLIDING ELECTRON BEAMS

Claudio Pellegrini and Andrew M. Sessler

November 18, 1969

AEC Contract No. W-7405-eng-48

JUL 20 1987

DOCUMENTS SECTION

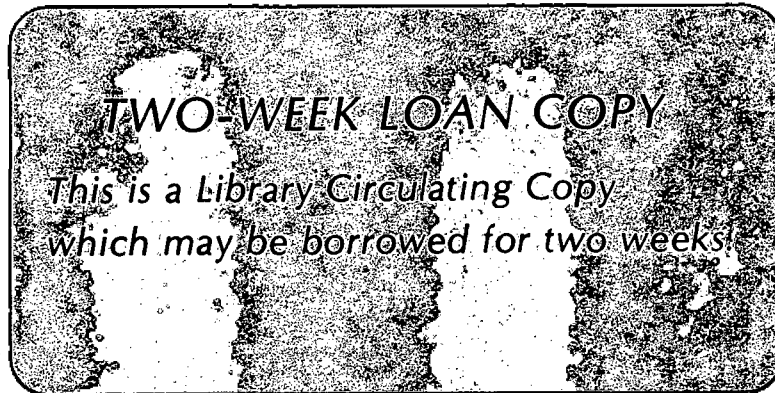

## **DISCLAIMER**

This document was prepared as an account of work sponsored by the United States Government. While this document is believed to contain correct information, neither the United States Government nor any agency thereof, nor the Regents of the University of California, nor any of their employees, makes any warranty, express or implied, or assumes any legal responsibility for the accuracy, completeness, or usefulness of any information, apparatus, product, or process disclosed, or represents that its use would not infringe privately owned rights. Reference herein to any specific commercial product, process, or service by its trade name, trademark, manufacturer, or otherwise, does not necessarily constitute or imply its endorsement, recommendation, or favoring by the United States Government or any agency thereof, or the Regents of the University of California. The views and opinions of authors expressed herein do not necessarily state or reflect those of the United States Government or any agency thereof or the Regents of the University of California.

## PHYSICS WITH AND PHYSICS OF COLLIDING ELECTRON BEAMS

Claudio Pellegrini and Andrew M. Sessler

Lawrence Radiation Laboratory  
University of California  
Berkeley, California

November 18, 1969

When particle physics is a closed subject which has been condensed into a text book, the material will surely be organized by concepts and not according to what fact was learned on what accelerator. But short of that day facilities must be designed, planned, and developed, and experiments must be executed on one of a number of available accelerators; and a very necessary point of view is to ask what physics can be done with one facility, in contrast to another. It is in this spirit that, in this note, we look at electron colliding beam devices.

In the first section we discuss the physics that can be done with colliding electron beams. After some general remarks we review the experiments already performed, and then turn to experiments planned for the future.

The physics that can be done with any accelerator is a strong function of the physics of the accelerator. Every reader of this Journal knows what determines the energy of an accelerator, but the physics that determines the beam intensity, quality, and pulse length is perhaps not so well known. (In fact, we plan to devote a future Comment to the physics that limits the performance of conventional accelerators.) In the second section of this note, we discuss the physics of colliding electron ring devices. Even more so than in conventional accelerators, the performance of colliding-beam devices is dominated by the physics of the machine, and hence our lengthy second section. But we trust it will be interesting, for the physics is subtle and there is beauty in it.

## 1. The Physics With

The main point is the energy available in the center-of-mass system. If the energy of each colliding beam is  $E = \gamma m_e c^2$ , the center-of-mass energy is  $2E$ ; in contrast, to attain the same center-of-mass energy with an electron hitting a stationary electron would require an accelerator energy  $E_{\text{equiv}} = 2\gamma^2 m_e c^2$ . We are talking about colliding beams in the GeV range, the factor of  $2\gamma$  is of the order of 4000, and  $E_{\text{equiv}}$  corresponds to an accelerator beyond rational contemplation.

A second point is the simplicity of the initial state. This is especially important in electron-positron collisions, where (with annihilation of the initial particles predominantly through one photon) the final states will have zero charge and strangeness, spin one, and negative parity. In particular, meson pairs can be produced in an environment undisturbed by strong interactions.

A third point is that the momentum transferred from the initial to the final state is time-like, whereas for most other experiments it is space-like, which means that colliding beams allow the study of a large range of phenomena otherwise unavailable.

And a last general point: Clearly the reaction rate must be considered; all the advantages come to naught if the experiments take forever. Equivalently, it is only the recently acquired ability to produce intense circulating beams that has made colliding beam devices firstly possible, and secondly capable of being employed to study small-cross-section reactions. A convenient measure of the reaction rate capability of an installation is the luminosity,  $L$ , which is defined as the ratio of the reaction rate to the reaction cross section--and consequently is cross-section-independent.

### 1.1. Experiments Performed

Colliding-beam devices have been employed to test quantum electrodynamics (QED); in fact the very first storage ring experiment was a study of  $e^-e^-$  collisions by the Stanford-Princeton group. (See Ref. 1 for a survey of colliding-beam experiments, and references to the original literature.) This experiment tests space-like photon propagators and the electron vertex function. It may be analyzed by writing the photon propagator,  $G_K$ , with a Feynman regulator:

$$G_K(q^2) = \frac{1}{[1 - q^2/K^2]},$$

where  $q^2$  is the momentum transfer. A value of  $K^{-2} = 0$  corresponds to a point-like electron and no cutoff on the photon propagator. Experiment with two beams--each of 550 MeV--yields  $K^{-2} = -(0.06 \pm 0.06) (\text{GeV}/c)^2$ , which is consistent with  $K^{-2} = 0$  and hence no breakdown of QED to this level of precision.

Surely the most exciting work with colliding beams--to date--has been the study of the  $\rho^0$ ,

$$e^+ + e^- \rightarrow \rho^0 \rightarrow \pi^+ + \pi^-,$$

first by the Novosibirsk group (on VEP-2) and subsequently by the Orsay group (on ACO), and the analogous study, by both groups, of the  $\phi^0$ .

The  $\rho$  experiments yield the  $\rho$  mass and width, and the branching ratio  $(\rho^0 \rightarrow e^+ + e^-)/(\rho^0 \rightarrow \pi^+ + \pi^-)$ . What was particularly interesting was the width  $\Gamma_\rho = 105 \pm 20$  MeV (Novosibirsk), and  $\Gamma_\rho = 112 \pm 12$  MeV (Orsay) which was quite different from the previously obtained values from reactions with strongly interacting particles present.

The  $\phi$  experiments, which are presently still in progress, yield the  $\phi$  mass and width, and the branching ratio  $(\phi \rightarrow e^+ + e^-)/(\phi \rightarrow K^+ + K^-)$ . The Orsay and Novosibirsk groups have also studied the branching ratios for  $(\phi \rightarrow K^+ + K^-)/(\phi \rightarrow K_1 + K_2)/(\phi \rightarrow \pi^+ + \pi^- + \pi^0)$ .

### 1.2. Experiments Planned

We can categorize colliding beam experiments into three groups: (1) QED, and final states without strong interactions, (2) meson production, and (3) baryon-antibaryon production. Different orders of magnitude of luminosity are required for each category. Frascati<sup>2</sup> (Adone with its energy of 1.5 GeV and  $L \approx 3. \times 10^{29} \text{ cm}^{-2} \text{ sec}^{-1}$ ), which has just started operation,<sup>3</sup> Novosibirsk<sup>4</sup> (VEP-3, with its energy of 3.0 GeV and  $L \approx 2. \times 10^{30} \text{ cm}^{-2} \text{ sec}^{-1}$ ), which will be ready in about one year, and Cambridge<sup>5</sup> (The By-Pass, with energy of 3.5 GeV and  $L \approx 2. \times 10^{31} \text{ cm}^{-2} \text{ sec}^{-1}$ ), which will be ready for experiments in perhaps a year, will all be able to investigate experiments in categories (1) and (2). Strong interaction physics must await the high-luminosity machine of DESY<sup>6</sup> (energy 3 GeV, peak luminosity--at 1 GeV--of  $5 \times 10^{32} \text{ cm}^{-2} \text{ sec}^{-1}$ ), or the (presently unauthorized) proposals of SLAC<sup>7</sup> (SPEAR) and Orsay<sup>8</sup> (Coppélia).

Typical QED experiments are  $e^+e^-$  elastic scattering (which tests QED for time-like and space-like virtual photons),  $e^-e^-$  and  $e^+e^+$  elastic scattering (which test QED for space-like virtual photons, but are possible only with DESY and SPEAR), and  $e^+ + e^- \rightarrow 2\gamma$  processes (which test QED for space-like virtual electrons).

Final states without strong interactions include the reaction  $e^+ + e^- \rightarrow \mu^+ + \mu^-$ , which studies time-like momentum transfer to the muon, in contrast--for example--with the  $g-2$  experiment, which primarily

studies space-like momentum transfers. Also, of course, are included searches for charged particles such as the weak-interaction vector-boson or possible heavy electrons more massive than the muon

Meson production experiments can be extended to study smaller branching ratios than are presently possible, such as  $\rho \rightarrow \pi^0 + \gamma$ ,  $\rho \rightarrow \eta + \gamma$ ; higher energy resonances; and also the nonresonant production of  $\pi$ 's.

Considerable interest is attached to the production of hadron pairs, for this allows a detailed study of the electromagnetic structure of a great range of stable and unstable particles. For example,  $e^+ + e^- \rightarrow p + \bar{p}$  studies the proton form factors for time-like momentum transfer (in contrast with space-like information from  $e^-$ -p scattering). No other way is available to study the electromagnetic structure of unstable hyperons. Studies of final states containing only a baryon-antibaryon pair will be most informative as it is such a simple configuration. For this reason alone, the construction of high-luminosity  $e^+e^-$  rings would appear to be justified.

Typical reaction rates, for a high-luminosity ring, are given in Tables 1 and 2. A dipole form factor model was employed to evaluate the cross sections.



Table 1. Reaction rates (in counts per second) for  $e^+e^-$  collisions at 1 GeV per beam, assuming a luminosity of  $10^{33} \text{ cm}^{-2} \text{ sec}^{-1}$ , and observation at all azimuthal directions having scattering angle between  $45^\circ$  and  $135^\circ$ . (Table taken from Ref. 8.)

<u>Final state</u>	<u>Counting rate</u>
$e^+ + e^-$	243
$\gamma + \gamma$	35
$\mu^+ + \mu^-$	14
$\pi^+ + \pi^-$	0.017
$\rho^+ + \rho^-$	0.75
$\rho + \pi$	0.35
$\pi^0 + \gamma$	0.003

Table 2. Reaction rates (in counts per hour) for hadron production under the same conditions as in Table 1, except for the indicated reaction energies. (Table taken from Ref. 8.)

<u>Final state</u>	<u>Counting rate</u>
$p + \bar{p}$ (1 GeV)	290
$\Lambda + \bar{\Lambda}$ (1.4 GeV)	1.3
$\Sigma^+ + \bar{\Sigma}^+$ (1.4 GeV)	9.7
$\Sigma^0 + \bar{\Sigma}^0$ (1.4 GeV)	4.3

## 2. The Physics Of

The experiments which can be done using a storage ring are determined by the beam energy and the luminosity. In terms of storage ring parameters,  $L$  is given by

$$L = fh \frac{N^+ N^-}{S},$$

where  $N^-$  and  $N^+$  are the number of particles in an electron or positron bunch,  $S$  is the effective transverse area of the beam and depends upon the crossing geometry (see Sec. 2.5),  $f$  is the revolution frequency, and  $h$  the number of bunches per beam. The possibility of reaching the high values of luminosity discussed in Section 1 has been the result of a long struggle to understand the phenomena that occur when high-intensity electron and positron beams are stored and made to collide.<sup>9</sup> A brief description of these phenomena and of the limitations they impose on storage ring capabilities is given in this section of this note.

### 2.1. Synchrotron Radiation, Radio-Frequency Fields, and Particle Motion

The emission of synchrotron radiation, by relativistic electrons going around a circular trajectory, plays an important role in storage rings.

One effect is to impose a practical limit on the maximum energy that can be reached. In fact, the average energy radiated per turn by an electron of energy  $E$  is

$$W = \frac{4}{3} \pi \frac{r_e}{\rho} \frac{E^4}{(m_e c^2)^3},$$

where  $r_e$  is the classical electron radius and  $\rho$  the radius of curvature of the trajectory. The energy lost by the particles must be supplied to the beams by a radio-frequency power system. The energy available must also exceed the energy lost, because of fluctuations in the power lost by synchrotron radiation. If this requirement is not met, the beam mean life can become exceedingly short.

Because of the  $E^4$ -dependence of  $W$ , the requirement on the radio-frequency power system becomes very difficult and costly to meet at high energy. In a storage ring of energy 3 GeV and radius of curvature of 20 m (corresponding to a guide magnetic field of 5 kG), one has  $W \approx 0.4$  MeV/turn. If the total circulating current is of the order of 2 to 20 A, as expected in the new storage ring devices, the power required for the radio-frequency system is in the range [0.8 to 8] MW.

Synchrotron radiation also has the effect of dividing the beam into bunches, since only particles crossing the radio-frequency cavities in a definite phase interval can receive the required amount of energy for survival. The radio frequency produces longitudinal oscillations of the particles. There exists a preferred particle, called the synchronous particle, which in going around the ring receives from the radio-frequency cavities the exact amount of energy lost by radiation and consequently has a revolution frequency which is an exact multiple of the cavity frequency. Particles which, at any given instant, have a slightly different frequency oscillate longitudinally around the synchronous particle.

In addition to the longitudinal oscillations, a particle also executes transverse oscillations around the single closed curve which is the equilibrium orbit of a synchronous particle.

Both the transverse and longitudinal oscillations are affected by synchrotron radiation. The radiation is equivalent to a dissipative force, and hence can either damp or antidamp the oscillations; which of the two possibilities occurs depend on the focusing properties of the storage ring. It is simple, with a proper design, to avoid the unstable situation.

Synchrotron radiation, being a quantum phenomenon, exhibits fluctuations, which also influence the oscillations. Under the combined action of damping and fluctuations, the oscillations have a nonzero rms amplitude. Also, other random effects, such as scattering on the residual gas, have an effect on the rms oscillation amplitude. However, synchrotron radiation is usually the dominant factor in determining the geometrical characteristic of the beams, which is an important factor in determining the luminosity.

## 2.2. Injected Current Limit

The luminosity obtainable with a storage ring depends strongly on the current which can be stored in the machine. In the process of injecting large currents (of the order of one or more amperes) the synchrotron radiation is of help because it allows the constraints of Liouville's theorem to be circumvented. Hence the limit on the number of stored particles,  $N$  (neglecting collective phenomena, which will be discussed below, and are often of dominant importance), is given by

- (i) injector current and beam lifetime (it should be noted that the beam lifetime during injection is usually different, and shorter than that after injection, because of the beam perturbation introduced by the injection mechanism.);

- (ii) radio-frequency power available.

### 2.3. Lifetime

The beam lifetime is determined by

- (i) interaction with the residual gas in the vacuum tank of the ring;
- (ii) Coulomb scattering between particles of the same beam (Touschek effect);
- (iii) interaction with the other beam;
- (iv) synchrotron radiation.

These effects all either change a particle's energy or transfer a part of the large longitudinal momentum of the particle into transverse momentum. The maximum transverse momentum of a stable particle is limited by the finite size of the vacuum chamber. Also, too large a change in longitudinal momentum brings a particle out of phase with the radio-frequency system, so that the particle is lost.

Of the effects listed, the most important is usually the interaction with the residual gas (elastic scattering on nuclei and bremsstrahlung). To obtain a reasonable lifetime, of the order of a few hours, the pressure in the vacuum tank must be lower than  $10^{-9}$  torr. An even lower pressure is also desirable near the crossing points of the beams in order to reduce the background in the experiments.

Pressures of the order of  $10^{-10}$  torr, or lower, can be obtained in storage rings for a small stored current and low beam energy. When the current or the energy is increased, the large amount of synchrotron radiation produced makes it difficult to maintain a good vacuum. This is because synchrotron light, striking the vacuum tank wall, produces

photoelectrons which in turn produce a degassing of the vacuum tank surface. Special designs of the vacuum tank are necessary in high-luminosity storage rings to limit this effect and to obtain the desired vacuum.

The synchrotron radiation introduces a--usually negligible--limit on the lifetime through the already mentioned fluctuations in the power radiated per turn.

The Coulomb scattering between particles in a beam causes losses because the scattering can transfer a part of the large longitudinal momentum of one particle to another particle in the same bunch. This effect is strongly dependent on the particle energy and is usually important only for low-energy beams (below 1 GeV).

Interaction with the other beam limits beam life essentially via the processes of electron-positron bremsstrahlung and scattering at low momentum transfer. However, this effect is usually less important than the interaction with the residual gas. It causes particle loss proportional to the luminosity, and because the cross sections for zero momentum transfer are well known, these processes can be employed to measure the luminosity.

#### 2.4. Coherent Instabilities

Coherent instabilities had been--prior to their elucidation--one of the main limitations in the operation of storage rings, since they limited the current which could be stably stored, and hence the luminosity.

Coherent instabilities arise because of the electromagnetic interaction between a beam circulating in a storage ring and its surroundings. This interaction can produce a transfer of a part of the large longitudinal beam momentum to any of the beam oscillation modes, and

hence leads to an increase in oscillation amplitudes and beam loss.

An example is the resistive wall instability. Assume that a bunch of particles oscillates around the equilibrium orbit in the vicinity of a resistive metallic wall, as illustrated in Fig. 1. We also assume the bunch to be much shorter than the oscillation wavelength, as is usually true in storage rings. The bunch produces in the wall a current which decays slowly with respect to the revolution period. Hence the current generated at one passage produces on the bunch, when it comes by again after one revolution, an attractive force.

It is clear that if the phase shift of the oscillation after one revolution is less than  $\pi$  this force tends to decrease the oscillation amplitude, and to give damping, while when the phase shift is larger than  $\pi$  it produces antidamping. Usually instead of the phase shift of oscillations in one revolution, one uses the wave number  $\nu$ , defined as the number of oscillation wavelengths in one revolution. So, in the above example, the motion is stable if  $n < \nu < n + \frac{1}{2}$ , and unstable if  $n + \frac{1}{2} < \nu < n + 1$ , where  $n$  is any integer.

Results of the same type apply if instead of a resistive wall the bunch of particles is interacting with any other structure, such as radio-frequency cavities, or electrodes, provided that the signal induced by the beam decays in a time long compared with the revolution period. Of course the stability and instability regions ( $n < \nu < n + \frac{1}{2}$ ,  $n + \frac{1}{2} < \nu < n+1$ ) can be reversed if the force produced by the structure is repulsive instead of attractive.

However, it is generally true that this kind of effect is strongly dependent on  $\nu$ , and that, when there is only a single bunch in the beam,

the instability can be removed by properly choosing the  $\nu$  value. This kind of analysis can be applied to both transverse (as illustrated in Fig. 1) and longitudinal coherent oscillations, and in fact both kinds of instabilities have been observed.

When there is more than one bunch in the beam, each bunch interacts with itself and with all other bunches. In this situation it is no longer possible to stabilize the beam by proper choice of the  $\nu$  value. In fact the beam can now be treated as an ensemble of coupled oscillators (each oscillator is equivalent to one bunch), being subject to nonconservative forces. It is clear that a part of the normal modes of this set of oscillators will always be unstable.

If the bunches have different oscillation frequencies, and if the differences between the squares of the oscillation frequencies are much larger than the linear coefficient of the force causing the instability (which is also the force coupling the bunches), then the coupling between bunches is of second order and can be neglected. In this case one can choose the single-bunch  $\nu$  value so as to stabilize all bunch modes. This method has in fact been employed in Adone to stabilize the longitudinal (phase) oscillations, which were unstable because of the interaction of the beam with the radio-frequency cavities; but it is usually difficult to apply to transverse oscillations.<sup>9</sup>

Transverse instabilities can also occur when the signal induced by the beam decays in a time shorter than the revolution period. Consider a beam with a single bunch and assume for simplicity that the bunch is made up of only two particles, A and B. These particles are oscillating longitudinally so that during half of the oscillation period A is the



"head" of bunch and B the "tail," and during the other half period the situation is reversed. If the head, A, starts to oscillate, the signal induced on the external structure interacting with the beam will cause oscillations of the tail, B. After half a longitudinal oscillation period, B is the head and will drive A. The process is clearly regenerative and can produce instabilities. The analysis of this case is more complicated than the analysis of the resistive-wall type of instabilities, since the effect is now dependent on the bunch structure. This leads to qualitative differences between the resistive wall type of effect (RWTE) and the head-tail effect (HTE), as, for instance: RWTE is strongly dependent on  $v$  and HTE is not; the rise time of the instability is dependent on the total beam current and is independent of bunch length for RWTE whereas it depends on the single bunch current and bunch length for HTE.

How does one handle instabilities? Of course one can design the ring so as to reduce to a minimum the presence of structures that can produce instabilities, but in practice this does not suffice. Also, one can choose  $v$  values properly, as described above, but there are instabilities for which this doesn't suffice. There are, however, other possibilities.

One stabilizing mechanism is provided by synchrotron radiation damping, which, however, is usually far too weak to allow for the storage of satisfactorily large currents.

Another possibility is to use a stabilization mechanism which is built into the beam itself. The focusing force for the transverse (or longitudinal) oscillations is linear only to a first approximation. The

nonlinearities in this force (primarily the cubic terms) give rise to a dependence of the oscillation frequency on the square of the oscillation amplitude, and hence to a spread of oscillation frequency in the beam. As a consequence, if we excite a coherent oscillation of the beam this will last, in the absence of coherent external forces, only for a time of the order  $1/\Delta f$ , where  $\Delta f$  is the frequency spread in the beam. If this decoherence time,  $\Delta f^{-1}$ , is shorter than the rise time of a coherent instability, the beam will be stable. Thus the frequency spread in the beam introduces an effective damping of coherent motion: Landau damping.

It is possible, within certain limits, to control and to increase the amount of Landau damping for a storage ring and thus stabilize the majority of beam modes. For the remaining modes, one can use the fact that the coherent instabilities, just because they are coherent, can induce signals on an electrode. These signals, properly amplified and phase shifted, can be fed back onto the beam so as to reduce the oscillation amplitude. This system has been successfully used in storage rings to control a few strongly unstable modes.

Everything that has been said in this section applies to the case in which only one beam is stored in the ring. The situation with respect to coherent-instability limitations is not qualitatively changed when two beams are present in the same storage ring, apart from the greater complication of the problem.

## 2.5. Incoherent Two-Beam Limit

Colliding two intense beams produces a new problem, namely, an incoherent beam-beam interaction, which, in practice, imposes the severest restriction upon storage ring design.

Each particle of a beam, for instance a positron, when crossing a bunch of the other beam is subject to a force due to the average electric and magnetic fields produced by the electrons. (We do not consider the "good" case in which an electron and positron come so near that a reaction occurs.) The electric and magnetic forces due to the electrons are both attractive and deflect the positron trajectory by an angle

$$\theta \approx \frac{2e \mathcal{E} l}{m_0 \gamma c^2},$$

where  $e$  is the positron charge,  $l$  the bunch length, and  $\mathcal{E}$  the electric field of the electron bunch. Assuming that the beams are cylindrical with radius  $a$ , and that the number of particles in the electron bunch is  $N$ , and that the positron crosses the electron bunch at a distance  $r$  from the axis, one can write  $\theta$  as

$$\theta \approx \frac{4\pi e N r}{\gamma a^2}.$$

In order to assure that the crossing occurs stably, and to avoid diffusion of one beam around the other, one must require

$$\theta < \frac{a}{\lambda},$$

$\lambda$  being the oscillation wavelength divided by  $2\pi$ , a quantity which in accelerator language is called  $\beta$  (and has an average value of the order of the ring radius divided by  $v$ ). Thus one obtains

$$\frac{4\pi e N \beta}{\gamma S} \lesssim 1,$$

where  $S$  is the beam transverse area.

The force acting between beams is, in reality, highly nonlinear. Consequently experiments and digital computation are required to better determine the limit in the above inequality; one finds that the right-hand side is reduced to  $\approx 1/3$ . The important thing is that the beam crossing strongly limits the number of particles per beam. This limit is called the "incoherent beam-beam interaction limit." If this limit is exceeded, the luminosity decreases and the beams become unstable.

However, since the luminosity depends on  $N$  but not on  $\beta$ , one can gain in luminosity by increasing  $N$  and decreasing  $\beta$  for fixed  $S$ . Reduction of  $\beta$ , at the crossing point, by factors up to one hundred times its average value, are considered for the CEA, DESY, and SPEAR storage rings. This, of course, somewhat complicates the design of the ring itself.

Another possibility for increasing the luminosity is to increase both  $N$  and  $S$  while keeping their ratio constant. Since the luminosity is proportional to  $N^2/S$  this procedure will also allow a gain. The most effective and practical way to increase  $S$  is to split the beam trajectories and to have crossing points where the trajectories cross with an angle  $2\delta$  (Fig. 2). In this case the effective transverse area is given by

$$S = a l \delta ,$$

where we assume  $l \delta \gg a$ .

The splitting of the trajectories can occur either in the vertical plane, as in Adone, CEA, DESY, and Coppélia design, or in the horizontal plane, as in the SPEAR design. In the Adone and CEA storage

rings the separation between the beam and the crossing angle  $\delta$  are not too large, so that the electron and positron beams are stored in one ring. In the DESY design,  $\delta$  is quite large, and the machine is built as two vertically superimposed rings with the beams switched from one ring to the other by means of electric fields. In the SPEAR design the even larger crossing angle is in the horizontal plane, with the crossing accomplished by magnetic fields. A possible advantage of the two-ring designs is that the interaction between the beams is reduced to only the crossing points. It also makes possible the storing of two electron or two positron beams.

A completely different approach (Coppélia) has been taken by the Orsay group for reducing the effect of the incoherent beam-beam interaction. Their suggestion is to store four beams, one electron and one positron beam in one ring, and another electron and positron beam in another ring. Assume one bunch per beam, as shown in Fig. 3; and assume, also, all the bunches, 1 to 4, to be equally populated. If we now consider a particle of the bunch 1, we can see that the forces on it due to bunches 2 and 3 cancel and only the force due to bunch 4 remains; however, for this force the elastic and magnetic contributions are of opposite sign, so that the total force is now reduced by a factor  $\gamma^{-2}$ . Of course, in practice, there will be slight inequalities between the bunches so that the effective force reduction will be somewhat less than  $1/\gamma^2$ .

### 3. The Past and The Future

The development of useful colliding-beam devices has been unbelievably difficult. We haven't emphasized it in the discussions of Section 2, but almost all the various phenomena we described were discovered--rather than predicted--in the course of trying to bring the first generation of storage rings into operation, and each had its associated delay and requisite ring modification. It would be unduly distressing to document the detail of the arduous effort required to isolate, understand, and control these diverse effects.

We hope it is history, but it is only candid to report that the latest beam instability (on Adone) was identified and circumvented only within this last year. And then, when finally Adone was ready for physics experiments, a social instability delayed use of the machine for five months! But we believe the physics that has been and can be done with storage rings should more than justify the effort that has been required to develop them.

If we gauge the future by extrapolation from the past, then we would expect that our understanding of the physics of storage rings is not complete, and new phenomena will be discovered as we press into new regimes. But we would also expect that the new difficulties will be overcome.

We look forward to a golden decade of colliding-beam research (including in our expectations the CERN p-p 25-GeV storage ring, and the Novosibirsk  $p\bar{p}$  25-GeV ring), but note with chagrin that although American physicists have contributed so much to the physics of colliding beams, they seem destined, because of economic instability, to reap so little from the physics with colliding beams.

Claudio Pellegrini  
Andrew M. Sessler

REFERENCES

1. S. C. C. Ting, in Proceedings of the Fourteenth International Conference on High-Energy Physics, Vienna, September 1968 (CERN Scientific Information Service, Geneva 23, Switzerland, 1968), p. 43.
2. F. Amman et al., in Proceedings of the Fifth International Conference on High Energy Accelerators, Frascati, September 1965 (Comitato Nazionale per l'Energia Nucleare, Roma, 1969), p.703.
3. F. Amman et al., Lettere al Nuovo Cimento 1, 729 (1969).
4. G. I. Budker, I. Ya. Protopopov, and A. N. Skrinsky, in Proceedings of the Sixth International Conference on High Energy Accelerators, Cambridge, 1967 (Cambridge Electron Accelerator Report CEAL-2000, Cambridge, 1968), p.102.
5. A. Hofmann et al., ibid, p.112.
6. Vorschlag zum Bau eines 3-GeV Elektron-Positron-Doppelspeicherringes für das Deutsche Elektronen-Synchotron (DESY, Hamburg, September 1967).
7. SPEAR Design Report (Stanford Linear Accelerator Center, Stanford, August 1969).
8. Projet D'Anneaux de Collisions Electron-Positron D'Energie Maximale 3 GeV à Charge D'Espace Compensée (Laboratoire de L'Accelérateur Linéaire, Orsay, September 1969).
9. A general review of storage ring instability problems, and further references, can be found in F. Amman, in Proceedings of the 1969 Particle Accelerator Conference, Washington, D. C. (IEEE Transactions on Nuclear Science NS-16, #3, June 1969, Part I), p.1073; and in Proceedings of the International Symposium on Electron and Positron Storage Rings, Saclay, September, 1966 (Presses Universitaires de France, 1967).

FIGURE CAPTIONS

- Fig. 1. A bunch of electrons oscillating in a transverse mode about the equilibrium orbit with  $\nu \approx 1 \frac{2}{3}$ .
- Fig. 2. Geometry of a beam crossing region.
- Fig. 3. The two-ring - four-beam Coppelia. Crossing occurs only at A and B, if there is only one bunch per beam.



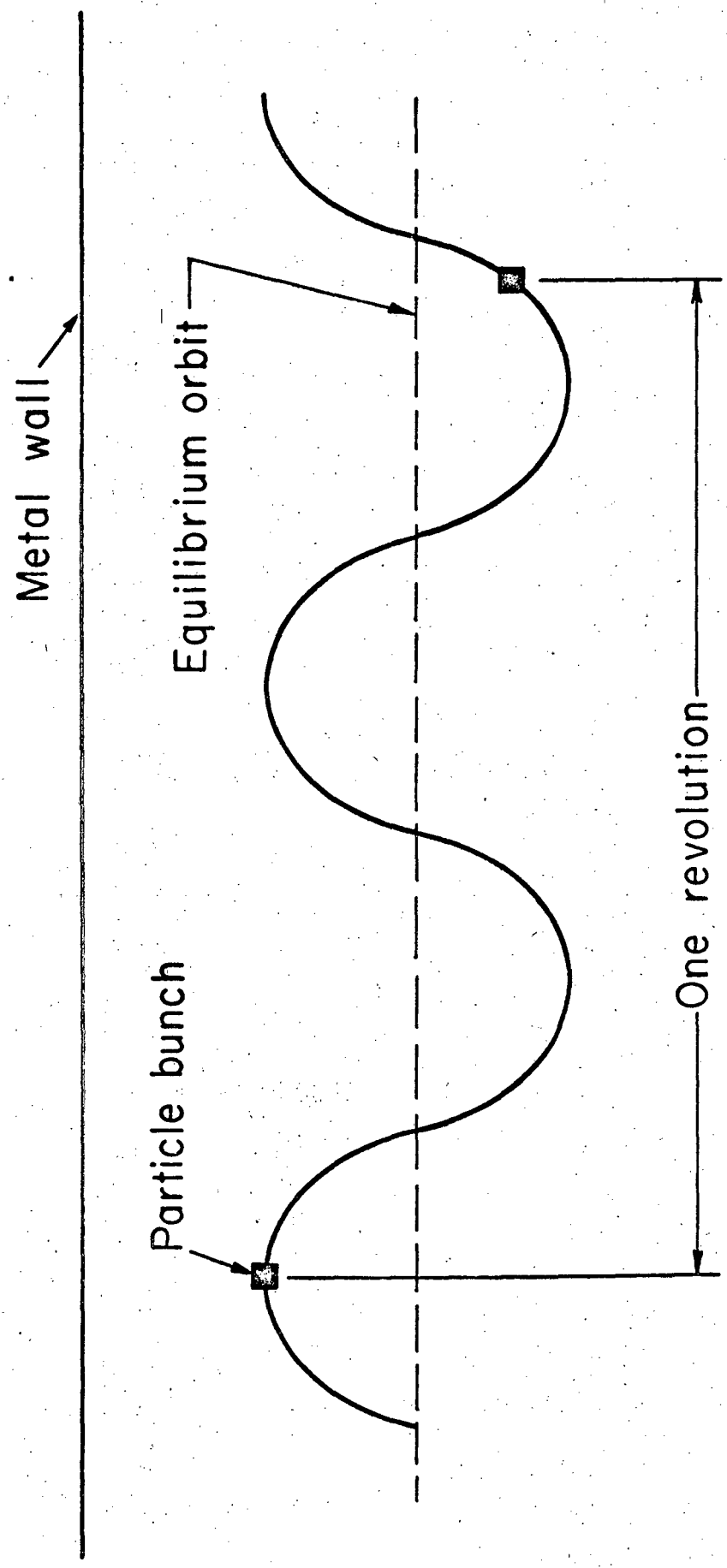

XBL 6911-6299

Fig. 1

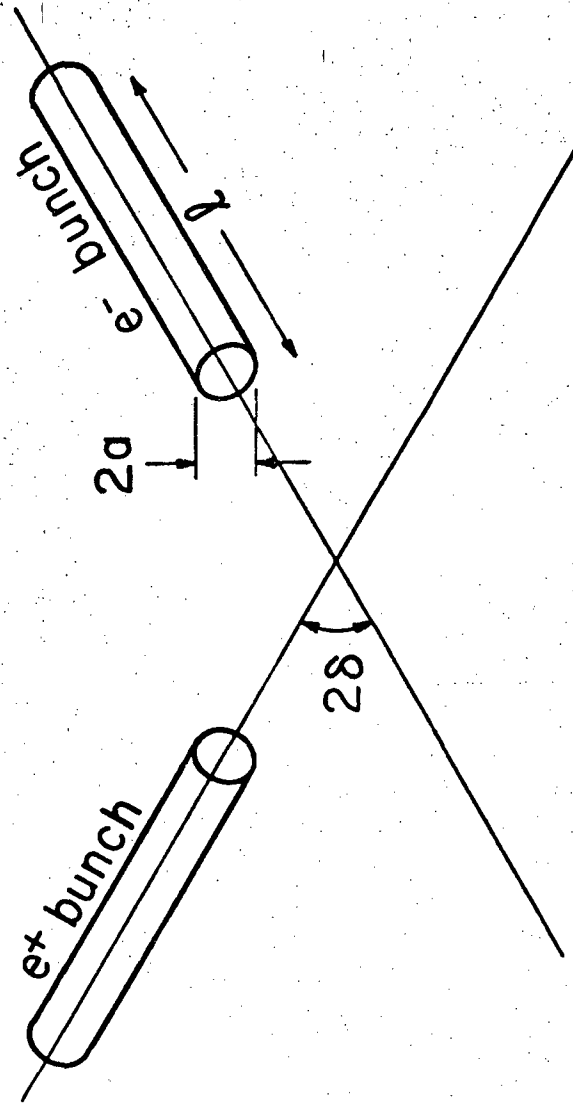

XBL6911-6300

Fig. 2

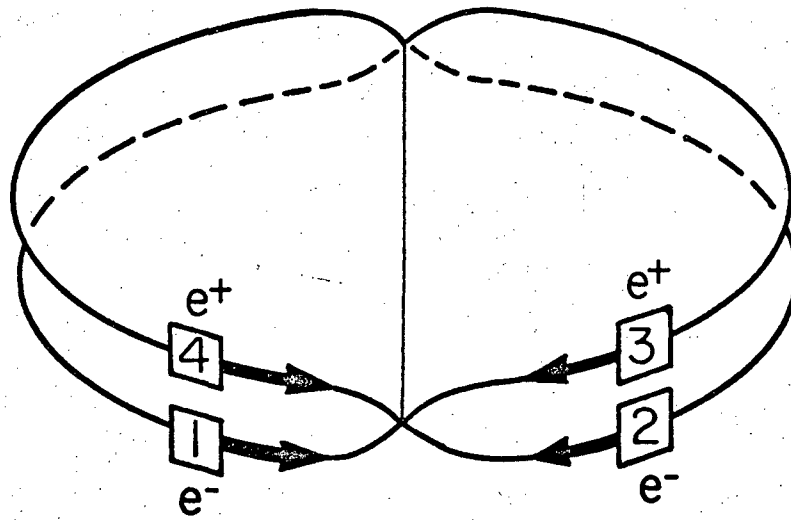

XBL6911-6301

Fig. 3

LEGAL NOTICE

*This report was prepared as an account of Government sponsored work. Neither the United States, nor the Commission, nor any person acting on behalf of the Commission:*

- A. Makes any warranty or representation, expressed or implied, with respect to the accuracy, completeness, or usefulness of the information contained in this report, or that the use of any information, apparatus, method, or process disclosed in this report may not infringe privately owned rights; or*
- B. Assumes any liabilities with respect to the use of, or for damages resulting from the use of any information, apparatus, method, or process disclosed in this report.*

*As used in the above, "person acting on behalf of the Commission" includes any employee or contractor of the Commission, or employee of such contractor, to the extent that such employee or contractor of the Commission, or employee of such contractor prepares, disseminates, or provides access to, any information pursuant to his employment or contract with the Commission, or his employment with such contractor.*

TECHNICAL INFORMATION DIVISION  
LAWRENCE RADIATION LABORATORY  
UNIVERSITY OF CALIFORNIA  
BERKELEY, CALIFORNIA 94720