

# Lawrence Berkeley National Laboratory

## LBL Publications

### **Title**

Joint Russian-American Hydrogeology Seminar

### **Permalink**

<https://escholarship.org/uc/item/33v2k4g7>

### **Author**

Lawrence Berkeley National Laboratory

### **Publication Date**

1997-07-01

# Proceedings of Joint Russian-American Hydrogeology Seminar

July 8-9, 1997

E.O. Lawrence Berkeley National Laboratory  
Russian-American Center for Contaminant Transport Studies

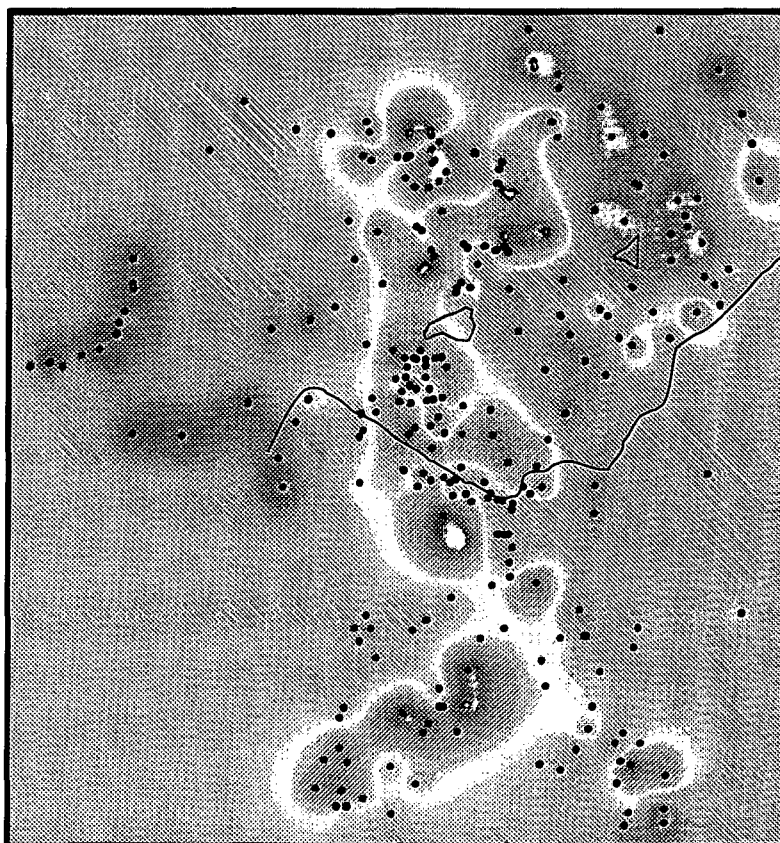

Edited by **C.F. TSANG, V. MIRONENKO and S. POZDNIAKOV**

This work was jointly supported by the U.S. Department of Energy, Office of Energy Research, Office of Basic Science, Geoscience and Engineering Division, under contract No. DE-AC03-76SF00098, and the U.S. Nuclear Regulatory Commission, Office of Nuclear Regulatory Research, under DOE-Work Order 60-97-389, JOB CODE W6891.

Lawrence Berkeley National Laboratory  
7th Street Warehouse

LOAN COPY  
Circulates  
For 4 weeks

PUB-804  
Copy 2

## **DISCLAIMER**

This document was prepared as an account of work sponsored by the United States Government. While this document is believed to contain correct information, neither the United States Government nor any agency thereof, nor the Regents of the University of California, nor any of their employees, makes any warranty, express or implied, or assumes any legal responsibility for the accuracy, completeness, or usefulness of any information, apparatus, product, or process disclosed, or represents that its use would not infringe privately owned rights. Reference herein to any specific commercial product, process, or service by its trade name, trademark, manufacturer, or otherwise, does not necessarily constitute or imply its endorsement, recommendation, or favoring by the United States Government or any agency thereof, or the Regents of the University of California. The views and opinions of authors expressed herein do not necessarily state or reflect those of the United States Government or any agency thereof or the Regents of the University of California.

**Proceedings of**  
**Joint Russian-American Hydrogeology Seminar**

A Compilation of Talk Summaries and Viewgraphs

*July 8-9, 1997*

E.O. Lawrence Berkeley National Laboratory  
Russian-American Center for Contaminant Transport Studies

Edited by

***C.F. Tsang***

*E.O. Lawrence Berkeley National Laboratory  
Berkeley, CA*

***V. Mironenko***

*Russian Academy of Sciences, Institute of Environmental Geology, St.  
Petersburg Division, St. Petersburg, Russia*

***S. Pozdniakov***

*Moscow State University, Moscow, Russia*

This work was jointly supported by the U.S. Department of Energy, Office of Energy Research, Office of Basic Energy Science, Geoscience and Engineering Division, under contract No. DE-AC03-76SF00098, and the U.S. Nuclear Regulatory Commission, Office of Nuclear Regulatory Research, under DOE-Work Order 60-97-389, JOB CODE W6891.

## TABLE OF CONTENTS

Introduction <i>Tsang C.F.</i> <i>E.O. Lawrence Berkeley National Laboratory</i> .....	1
Environmental problems at the Mayak site <i>Drozhko Eu. G. and Glagolenko Y.U.</i> .....	4
Mayak site characterization: interpretation of field tests for evaluation of hydraulic properties of fractured rocks <i>Drozhko E.G., Ivanov E.A., Samsonova L.M., and Vasil'kova N.I.</i> .....	15
Geotechnical monitoring of underground water deep injection wells and basins of liquid radioactive waste sites of Siberian Chemical Combine <i>Zubkov A. A.</i> .....	34
Study of radionuclides transport in deep-well injection of liquid radioactive wastes in Russia <i>Rybalchenko A. I.</i> .....	46
Preliminary assessment of radionuclides migration from the HLW repository: PA "Mayak" site, South Urals, Russia <i>Malkovsky V.I and Pek A. A.</i> .....	59
Migration of liquid plume in the sloping aquifer <i>Malkovsky V. I., Pek A.A. and Tsang C.F.</i> .....	70
Efficient strategy of ground water quality control and remediation at old contaminated sites <i>Mironenko V. A.</i> .....	90
Salt-water convection in porous media on different scales <i>Kuvaev A. A.</i> .....	108
Modeling of ground water contamination caused by organic pollutants <i>Pashkovsky I. S.</i> .....	117
Non-equilibrium flows of fluids in natural rocks <i>Barenblatt G. I.</i> .....	124
Isolation of radioactive waste in permafrost rock <i>Grant S. A.</i> .....	162
Hydraulic characterization: A history of ideas <i>Narasimhan T. N.</i> .....	181

Potential remediation measures at Mayak site	
<i>Parker F. L.</i> .....	194
Comments	
<i>Drozhko Eu. G.</i> .....	206
Class I deep well injection - nature's subsurface treatment of injected waste	
<i>Clark E. J.</i> .....	210
Arsenic in ground-water of Minnesota: hydrogeochemical modeling and regional trends	
<i>Kanivetsky R.</i> .....	217
Modeling fate and transport of petroleum constituents in vadose and saturated zones using SESOIL and AT123D	
<i>Prilepin V. M.</i> .....	231
Contaminant hydrogeology of radionuclides at LLNL site 300	
<i>Taffet M. J.</i> .....	247
Hydrophysical logging: a review of applications and case studies	
<i>Pedler W.H.</i> .....	275
Mayak site characterization: spatial hydraulic heterogeneity	
<i>Drozhko, E.G., Samsonova L. M., Vasil'kova N. I., Pozdniakov S. P. and Tsang C.F.</i> .....	303
Neuro-statistical method for contaminant site	
<i>Nikravesh M.</i> .....	312
Geophysical logs and tests required for class I deep disposal wells	
<i>Smith, Robert E.</i> .....	330
Discussion highlights	
<i>Mironenko V.A., and Tsang C.F.</i> .....	333
Seminar Agenda.....	338
List of Participants.....	342

# Introduction

**Chin-Fu Tsang**

E. O. Lawrence Berkeley National Laboratory

July 8 - 9, 1997

**JOINT RUSSIAN-AMERICAN HYDROGEOLOGY SEMINAR**

Russian - American Center for Contaminants Transport Studies  
Ernest Orlando Lawrence Berkeley National Laboratory  
Berkeley, California 94720

Hydrogeology research has been very active in both Russia and the U.S. because of the concerns for migration of radioactive and chemical contaminants in soils and geologic formations, as well as for water problems related to mining and other industrial operations. Russian hydrogeologists have developed various analysis and field testing techniques, sometimes in parallel with U.S. counterparts. They also have substantial case histories (e.g., Chelyabinsk, Tomsk, and others), which are of significant interest to hydrogeologists in general.

These Proceedings come out of a Seminar held to bring together a small group (about 15) of active Russian researchers in geologic flow and transport associated with the disposal of radioactive and chemical wastes either on the soils or through deep injection wells, with a corresponding group (about 25) of American hydrogeologists. The meeting was intentionally kept small to enable informal, detailed and in-depth discussions on hydrogeological issues of common interest. Out of this interaction, we hope that, firstly, we will have learned from each other and secondly, that research collaborations will be established where there is the opportunity.

The LBNL Russian-American Center for Contaminant Transport Studies was set up in 1993 for the purpose of promoting in-depth scientific interaction and research collaborations between Russian and American scientists. It is under the auspices of the Center that this Seminar was organized and conducted. We were happy that we were able to attract a number of the most active and authoritative hydrogeologists from Russia to attend. These included Drs. Eugene Drozhko and Yuri Glagolenko of Mayak P.A., and Nelly Vasil'kova of PSA Hydrospeztzgeologiya, who have been investigating the hydrogeology of the most radioactively contaminated site in the world, the Chelyabinsk-Mayak site. Dr. Andre Rybalchenko, who has been studying deep injection disposal of liquid radioactive wastes for many years, came with Dr. A. Zubkov, who is involved in geotechnical monitoring of deep injection wells in Tomsk. From Russian Academy of Sciences were Drs. G.I. Barenblatt, Valery Mironenko, Alex Pek and Victor Malkovsky, representing many years of experience in the dynamics of fracture hydrology and hydrogeology of mines. Dr. Barenblatt was recently made a foreign member of the U.S. National Academy of Sciences. Drs. Sergey Pozdniakov and Andre Kuvaev came from Moscow State University and Dr. Igor Pashkovsky from Geolink Company. We were also pleased to receive Dr. Yuri Tatarchuk, the Director of PSA Hydrospeztzgeologiya, who provided insights from his many years of experience of doing geology in Russia.

This group of Russian hydrogeologists was joined by U.S. scientists in the Seminar for two days of discussions that were informal, open and intense. This proceedings presents the summaries and viewgraphs from the presentations. What cannot be conveyed here is the warm and cooperative atmosphere of these interactions, both inside and outside the formal sessions, which may well lead to future collaborations. One example of a possible



future joint effort is the proposal of establishing an international council of deep injection disposal of liquid wastes, which will be pursued in the coming days by several participants of this Seminar.

For the organization of this Seminar, we would like to express our appreciation for the consistent and continuing support of Berkeley Lab Director Charles Shank, Deputy Director Pier Oddone and Dr. Sally Benson, who is the Director of the Earth Sciences Division of the Berkeley Lab. We are also most grateful for the advice and guidance over the years from the Scientific Advisory Committee of the Center, Dr. N.N. Egorov of Russian Federation Ministry of Atomic Energy, MINATOM, Academician N.P. Laverov of Russian Academy of Science, and Professor G.T. Seaborg of Berkeley Laboratory. The interest and encouragement, as related to deep injection disposal, from Bruce Kobelski and Robert E. Smith of The Environmental Protection Agency, Office of Drinking Water and Ground Water, are very much appreciated. We are thankful for the funding support jointly from the U.S. Department of Energy, Office of Energy Research, Office of Basic Energy Science, Geoscience and Engineering Division and from the U.S. Nuclear Regulatory Commission, Office of Nuclear Regulatory Research. Bechtel Environmental Company of San Francisco also provided a gift to support some of the activities of the Seminar, which is gratefully acknowledged.

# **Environmental problems at the Mayak Site**

**Drozhko Eu. G. and Glagolenko Y. U.**  
Production Association MAYAK

July 8 - 9, 1997

## **JOINT RUSSIAN-AMERICAN HYDROGEOLOGY SEMINAR**

Russian - American Center for Contaminants Transport Studies  
Ernest Orlando Lawrence Berkeley National Laboratory  
Berkeley, California 94720

Lake Karachai (reservoir 9) is situated in the territory of "Mayak" PA. Since October 1951, the lake was used as the depository for technological radioactive waste, permitting the stopping of discharge of waste into the river Techa. By the autumn of 1962, the water level of the reservoir was increasing, and the water area had enlarged to 510,000 m<sup>2</sup> as the result of the discharge. The period of 1962-1966 was the low water period. Water level decreased, and about 23 000 m<sup>2</sup> of the banks and 20 000-30 000 m<sup>2</sup> of the reservoir were exposed. About 600 Ci was transferred from the exposed banks of the reservoir because of wind re-suspension of the bottom sediments. The major part of transferred radionuclides precipitated close to Lake Karachai, but also at sites northeastward and eastward from the enterprise. After this accident, special work was conducted to eliminate the recurrence of such accidents. During 1967-1971, the bare parts of the banks and shallow places were covered. Then the edge of the reservoir was graded and reinforced with stone. As the result of this work, the banks of the lake were raised along the whole perimeter, and its water area decreased to 36 ha. As part of regime observations, water level monitoring was started. When the water level was lower than the allowable mark, clean water was added to the reservoir. Because of filtration of the industrial solutions through the bottom of the reservoir, and their further migration to the discharge zones, contamination of the ground water around the reservoir occurs.

Presently, Lake Karachai contains about 120 million Ci of beta-active nuclides. During the time period this reservoir was used as the depository, about 3.5 million m<sup>3</sup> of industrial solutions were discharged to ground waters. The contaminant ground water plume, with an area of 10 km<sup>2</sup>, was formed under the lake. The velocity of the spatial distribution of contaminated ground water in some directions is 80-100 m/year. By the 1990s, the contaminant plume neared the Mishelyak River. Because Lake Karachai is the source of the radioactive contamination, it was decided to eliminate its water area. In 1978-1986, a special technology was created to cover the reservoir with rock and hollow concrete blocks, which allowed us to immobilize bottom sediments. From 1985 to the

present, work on covering the lake continues. As a result, the water area of Lake Karachai was about 150 000 m<sup>2</sup> by the end of 1995. Eighty percent of the radionuclides which were accumulated during the period the lake was used were localized within the covered area. The entire work should be completed, with the total elimination of the water area and its technical recultivation, in the course of the "green loan".

Experiments on estimating the impact of Lake Karachai on the environment have been held since the beginning of its use as a depository. Special observation posts to monitor surface contamination were installed, and the network of hydrogeological monitoring wells was equipped to trace the spread of contamination in the underground hydrosphere. Besides, detailed observations of the geological, structural, and tectonic zoning of the area were conducted, and hydrological conditions, migration parameters, etc. were verified.

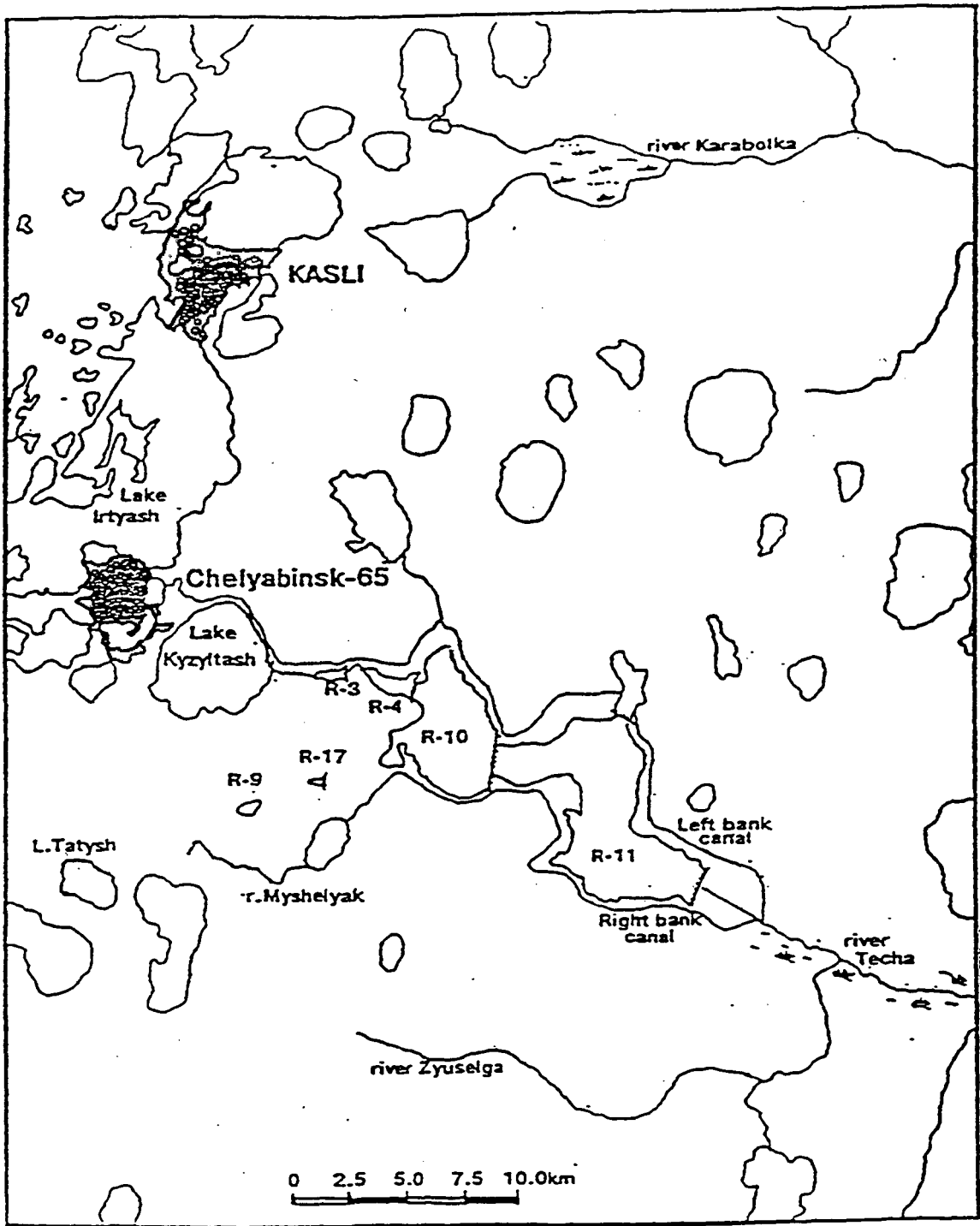



Рис.4. Схематический вертикальный разрез водоема-9.

Отражено распределение техногенных донных отложений, принятое при моделировании:

- справа - берег, созданный отсыпкой - закрытием бывшей акватории водоема; донные отложения возле него характеризуются повышенной мощностью вследствие вытеснения (стрелками указано направление отсыпки);
- слева - естественный берег с укрепленным камнем откосом, у которого донные отложения выклиниваются до нуля (или же берег, где из-за незначительного количества техногенных донных отложений не происходит увеличения их мощности перед фронтом отсыпки).

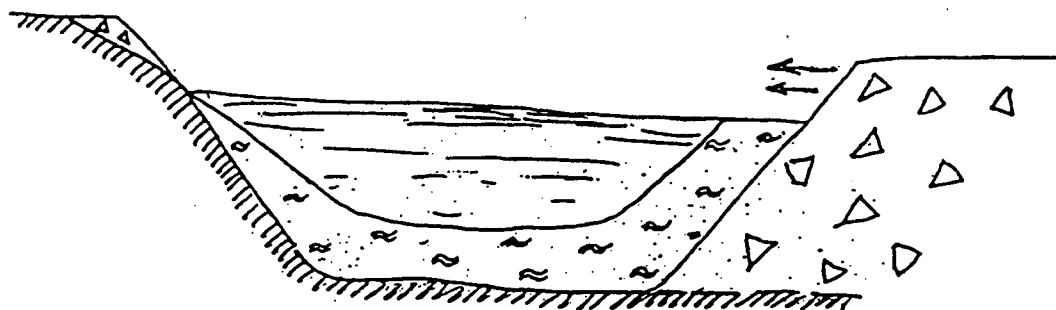
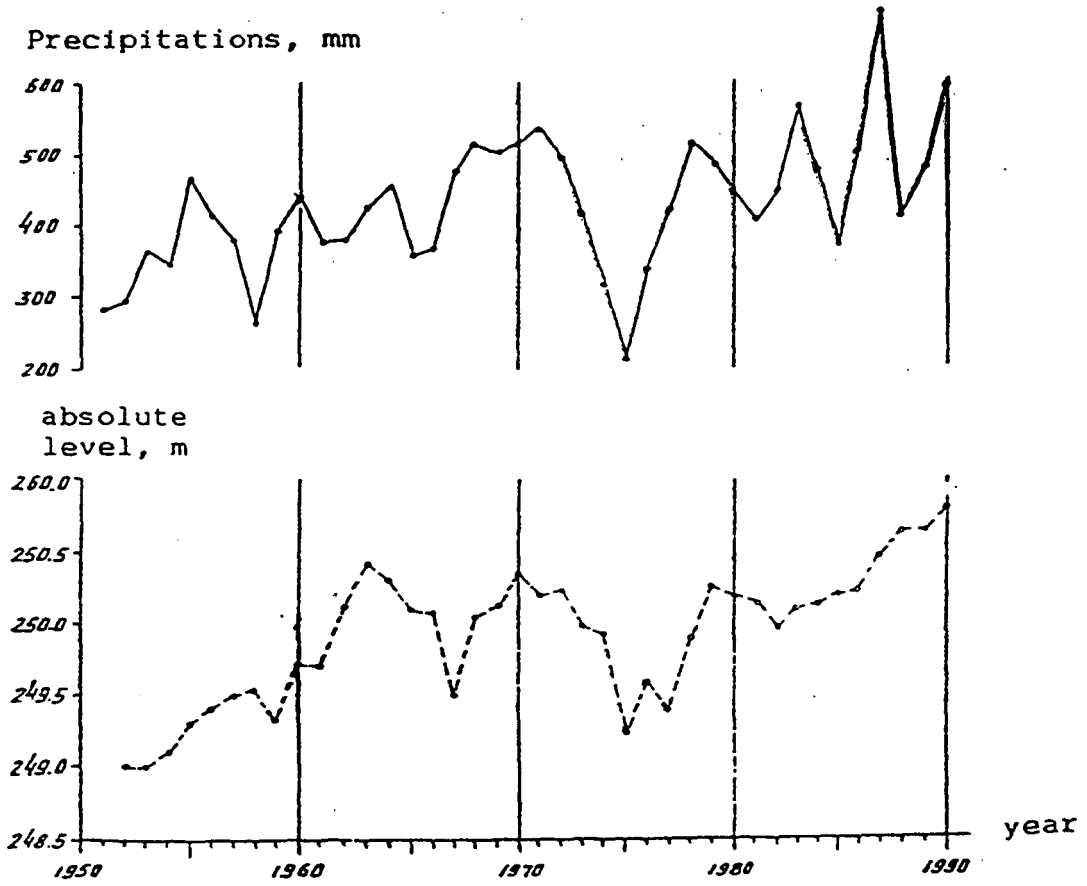

Fig. 2.6. Atmospheric annual precipitations (according to Chelyabinsk-65 meteorostation) and water level in l. Karachay. Dumping is subtracted



Рис.4. Схема расположения пунктов контроля водных объектов

○ - пункты контроля



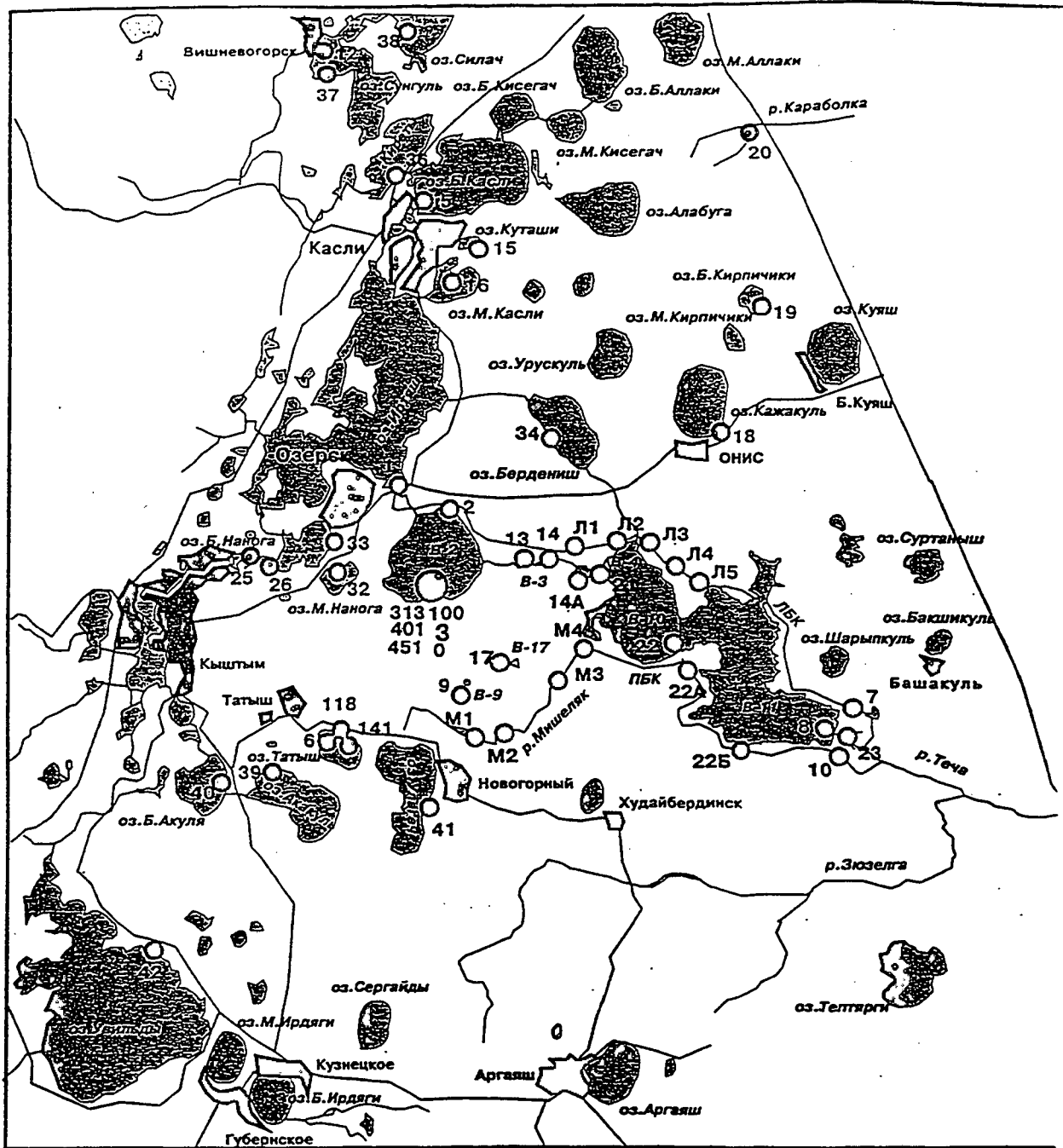

рис. 13 Разгрузка потока подземных вод в реку Мишельки (на участке реки моделируемой области).

1-водозабор п.Новогорный работает. 2-водозабор п.Новогорный отключен в 1996 г.

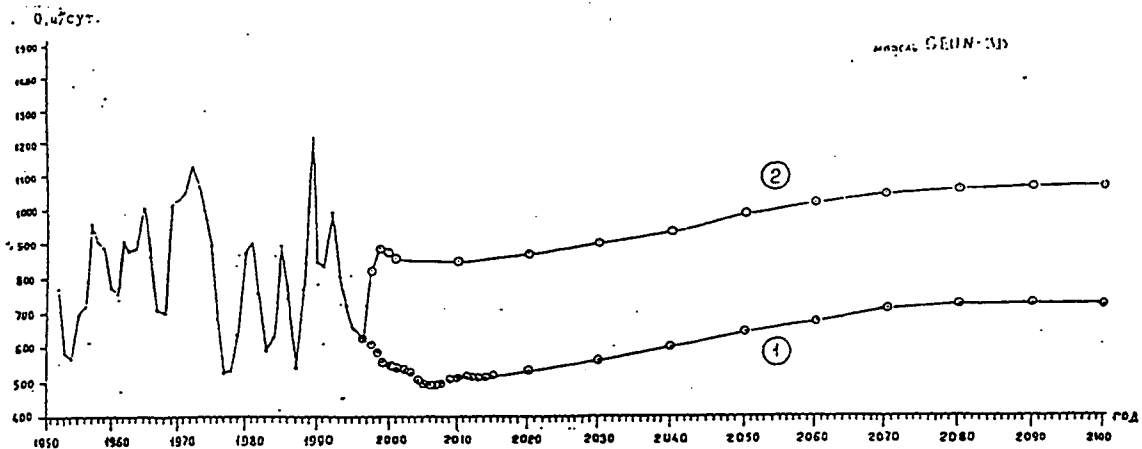

рис. 14. Разгрузка нитрат-иона в реку (QS).

1-водозабор работает. 2-водозабор отключен.

существенное загрязнение гидросети. Объектами потенциального ущерба будут места возможного выхода загрязненных подземных вод на поверхность земли и действующие водозаборные сооружения для эксплуатации подземных вод, расположенные на путях распространения загрязнения.

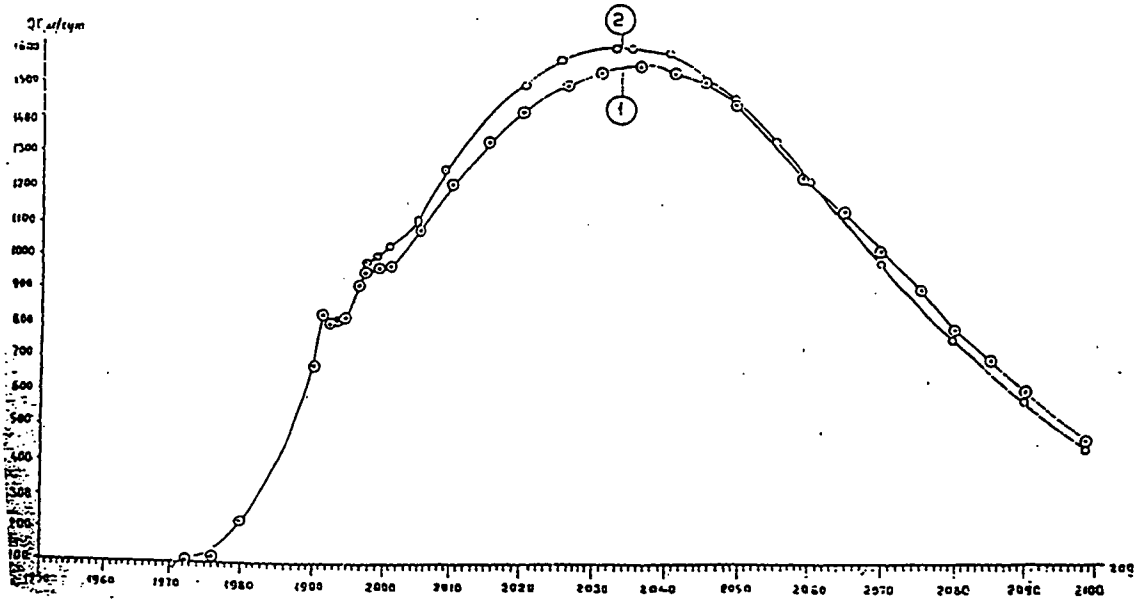

Рис.6. Распространение загрязнения от водоема Карачай в горизонте подземных вод по состоянию на март 1994 г.



Contours of nitrates in ground waters, 1990

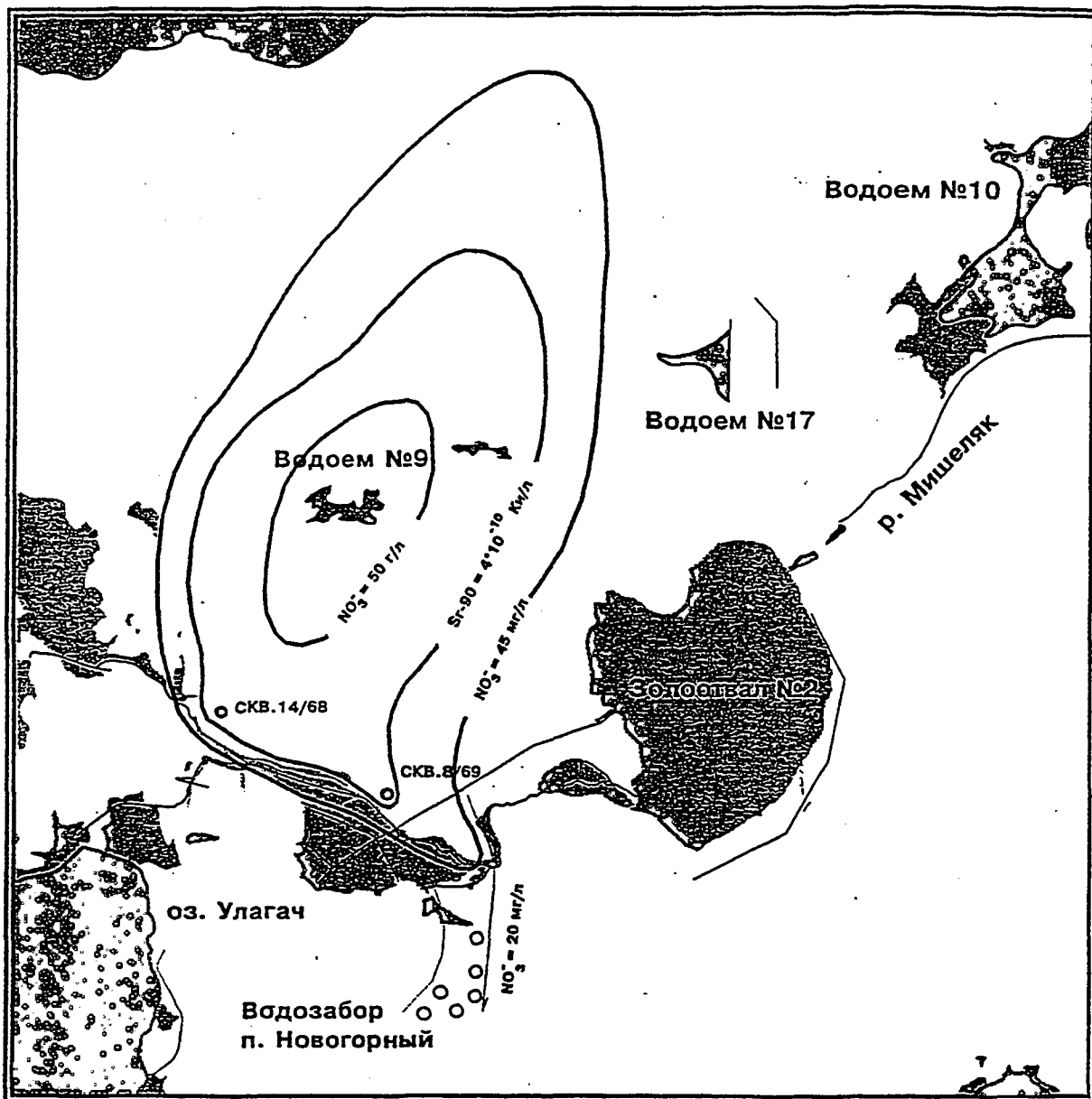
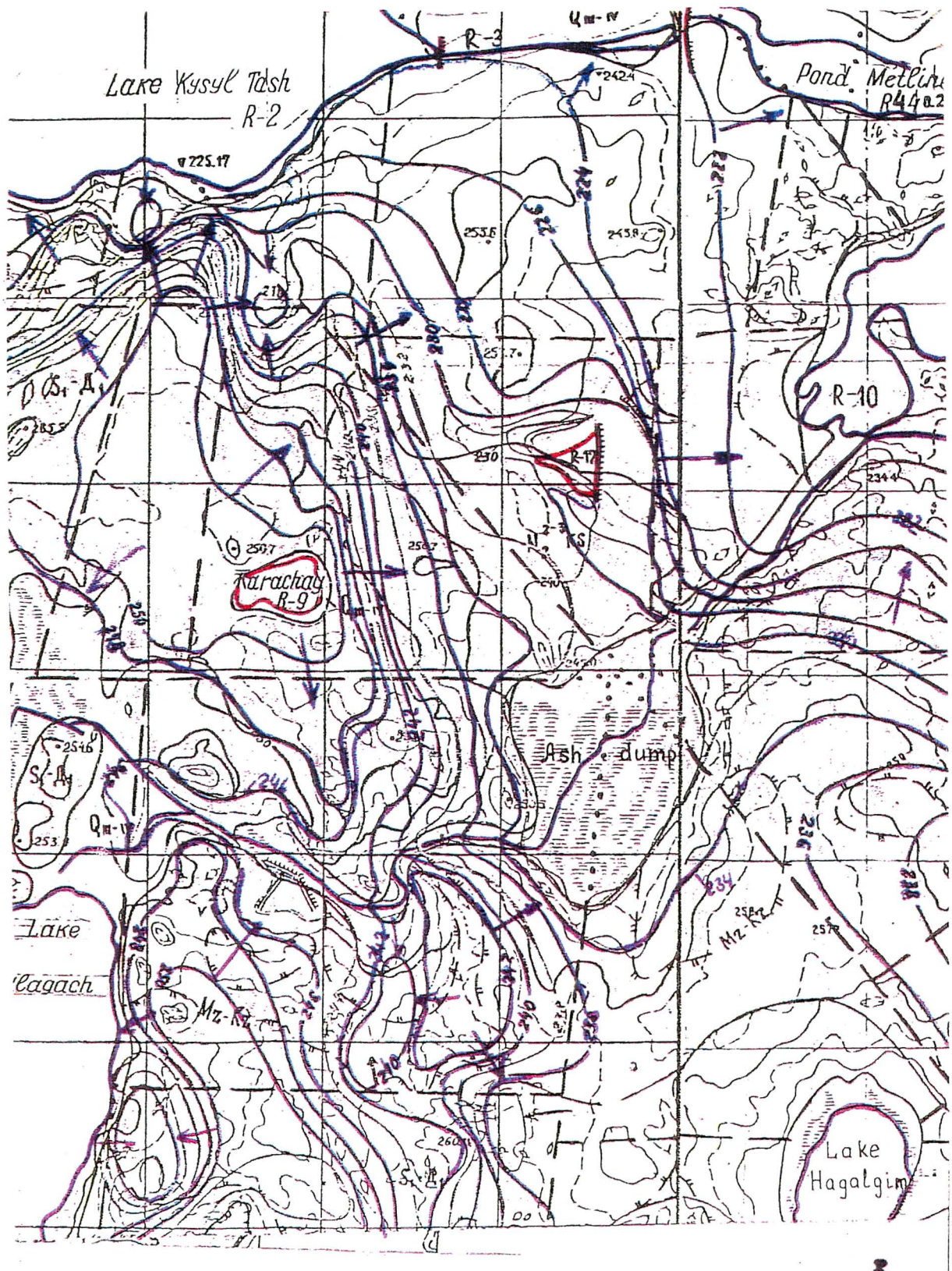
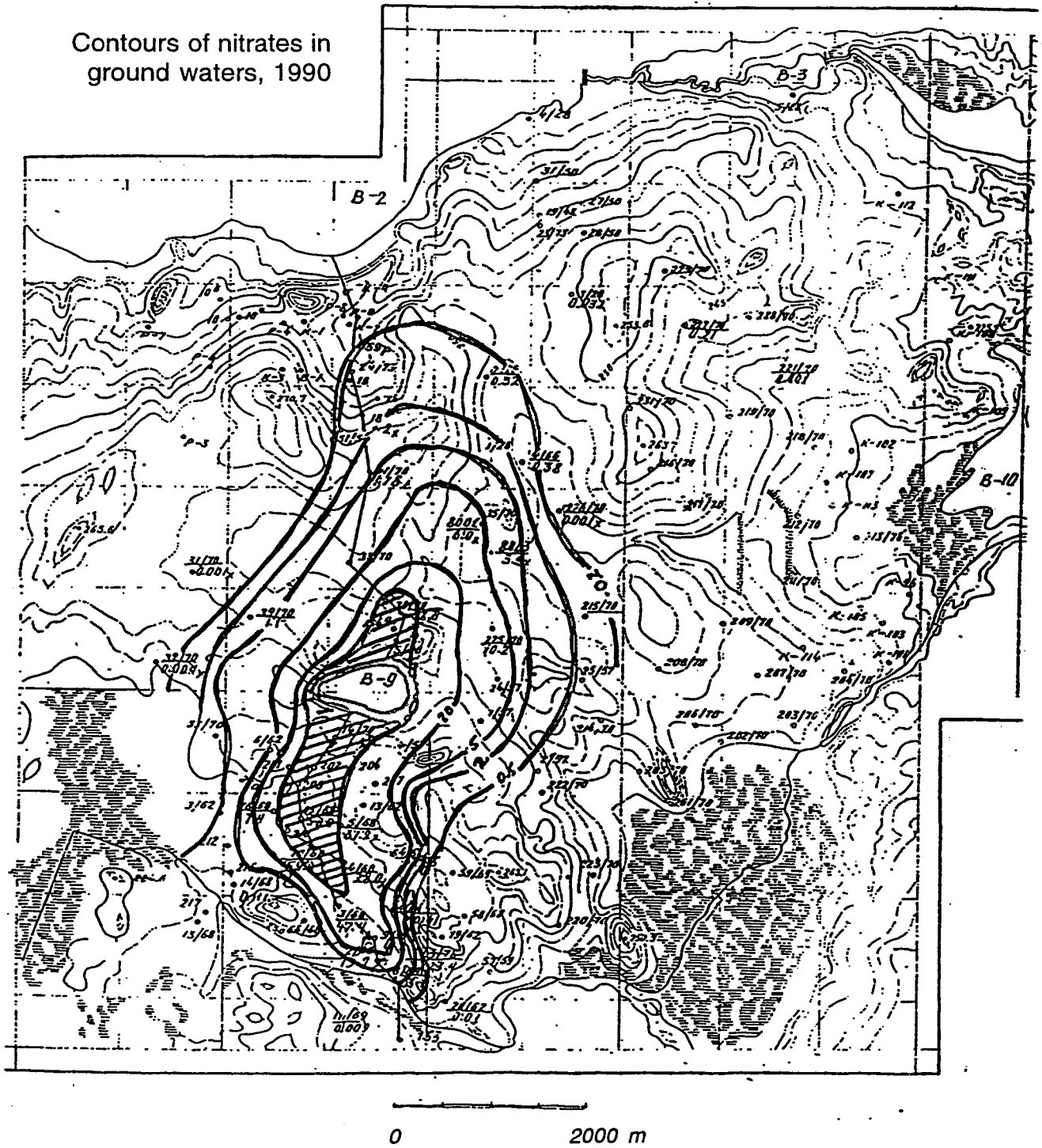

**Mayak Site Characterization:  
Interpretation of Field Tests for Evaluation  
of Hydraulic Properties of Fractured Rocks**

**Drozhko Eu. G. , I. A. Ivanov, A. Aleksakhin**  
Production Association MAYAK  
**Samsonova L. M. and Vasil'kova N. I.**  
P.S.A. Hydrospetzgeologia

July 8 - 9, 1997

**JOINT RUSSIAN-AMERICAN HYDROGEOLOGY SEMINAR**

Russian - American Center for Contaminants Transport Studies  
Ernest Orlando Lawrence Berkeley National Laboratory  
Berkeley, California 94720

Lake Karachay is the main source of ground water contamination for the investigated area. During the time this reservoir was used for liquid waste storage, about 3.5 million m<sup>3</sup> of industrial solutions were discharged to ground waters. Industrial solutions of high density pass from the reservoir into the ground water, forming the plume of chemical and radioactive contamination with an area of 10 km<sup>2</sup>. Ground water density within the plume is 1.02 - 1.04 g/cm<sup>3</sup>. Monitoring of the contaminant migration is being conducted through a system of observation wells. The calculated velocity of contaminant plume spreading exceeds 70 m/year. This situation demonstrated the necessity of a scientifically well-grounded prediction of contaminant transport in ground water. There were three matters of concern that required prediction: contaminant plume spreading both in plan and with the depth; assessment of the values of possible contaminant discharge into the Mishelyak river; and estimation of the efficiency of proposed countermeasures aimed to prevent the contaminant plume from discharging into the river.

The contaminant migration is governed by several natural and artificial factors. In this special case, numerical modeling is considered to be the best instrument for forecast calculations. The development of a numerical model of the contaminant transport from Lake Karacha in ground water in the Mayak site was initiated in 1990. Models have been developed within the framework of joint activities of PSA Hydrospeztzgeologiya (Moscow, Russia), Institute of Physics and Power Engineering, IPPE, (Obninsk, Russia), and Production Association (PA) Mayak (Ozersk, Russia). The work has been implemented simultaneously in two directions: one is the development of software for modeling; the second is the definition of the conceptual scheme of the modeled domain and provision of the model input data. This work was accomplished, taking into account the following :

- i. the high density of the contaminating solution,
- ii. the fractured rock mass is strongly heterogeneous and anisotropic,
- iii. the high velocity of contaminant migration,

- iv. the relatively high level of ground water in the area containing contamination, and the hydraulic connection between ground and surface water.

The modeled domain consists of highly fractured rocks. Two types of fracturing were defined. One of them, so-called 'regional' fracturing, includes weathering fractures and lithogenetic fractures. The linear fractured zones are of tectonic origin. The predominant North-South direction of these zones is the common orientation of the Ural's tectonic structures. Fractures of different types superimpose, and as a result, the rock mass has a definite block structure. The range of fracturing may vary within wide limits, both in plan-view and in depth. Ground waters are contained by the fractured rocks, weathered zones of these rocks, and by alluvial deposits. All water-bearing horizons are interrelated and form a unified aquifer with a common water table and common ground-water flow. The thickness of this unified aquifer is determined by the thickness of the zone of regional fracturing, and varies from 50 - 80 to 130 - 190 m. Watered zones of fractures sometimes occur at depths 500 m and more, but they cannot be considered as part of the unified aquifer.

Over 30 years, about 300 wells were drilled within the territory with the aim to monitor contaminant transport. Well investigations include stratigraphic and structural interpretation, revealing fractured zones, hydraulic properties determination, telephotometry, resistivity logging, and other types of geophysical logs. All hydraulic tests conducted can be divided into the following types:

- 1) single well pumping tests;
- 2) injections into screened intervals of the well, or packer tests;
- 3) cluster pumping tests.

The reliability of the information obtained by different types of tests varies. The data of cluster pumping tests are considered to be the most reliable. The distinctive feature of water-bearing rocks are the nonuniform values of transmissivity and appreciable anisotropy. For example, a cluster pumping test is described. The productive well 225/70

(Fig. 2) penetrated the fractured porphyrite in the depth interval 12-51 meters. The duration of this pumping test was 8 days. The anisotropy of transmissivity is illustrated by Fig. 5, where the depression cone shown by isolines of drawdown has an elliptical form. The graphs of drawdown in observation wells show the distinct quasi steady-state filtration regime (Figs. 3,4). The average values of transmissivity  $T$  and hydraulic diffusivity  $a$  were calculated.  $T$  is equal to 200 m<sup>2</sup>/day. The parameter  $T$  calculated for the direction of line I is 1.4 times smaller than  $T$  defined for perpendicular line II. The results obtained by the field tests show that transmissivity ranges from 0.7 to 800 m<sup>2</sup>/day. Such a wide range of parameter values points out that the water-bearing rock is very heterogeneous. Thus, it is incorrect to extrapolate values of the rock's hydraulic properties obtained at a discrete point to the entire rock massif. Accordingly, the modeled domain was divided to rather small zones in which the hydraulic properties were taken to be homogeneous. This scheme was verified by a calibration procedure of the 2-D model. The hydraulic head measured in monitoring wells was used as the calibration target, together with the calculated annual rate of discharge from Karachai Lake to the ground water. The 3-dimensional problem required additional information about the vertical structure of the modeled domain. Here, each sector marked as conventionally homogeneous was represented as a layered mass in cross section, and the layers were defined by their conductivity and fractured porosity. To obtain these values the following information was used :

- the results of the intervals injection which had been carried out in 1968 -1970;
- the curves of rock fracturing obtained by well core investigation;
- the results of statistical processing of the hydrogeological parameters from data of single well tests;
- the results of characterizing the fracturing by the telephotometry method;
- the results obtained by cluster pumping tests from wells penetrating different depth intervals.



The obvious information about hydraulic conductivity distribution in depth was obtained by interval injections. The calculated parameters were correlated with the number of fractures per 1 m of the core in the injected wells. For this purpose, the graphs for fracturing and hydraulic conductivity with depth were grouped for the wells situated to the north (Fig. 6) and to the south from B-9 (Fig. 7) The dependence between the parameters and their decrease in depth was adjusted by comparison of the curves for 25 wells, with the exception of the cases when separate large fractures at depth provide significantly increasing inflow.

However, such exceptions are not representative for the modeled domain. Therefore it is assumed that highly fractured rocks (more than 10 fractures per meter) with maximal hydraulic conductivity values, are distributed up to depths 30- 50 m from the surface. Below in cross section, rocks grade into mid- and slightly fractured, and pass into a uniform mass of a relative aquitard. Predominant hydraulic conductivity values in the interval from 30-40 m to 70-80 m vary from 0.01 to 0.5 m/day. The depth of the rocks with hydraulic conductivity values less than 1.0-2.0 m/day and with fracturing less than 10% of common fracturing in the section, was accepted as the top boundary of the relative aquitard. Besides the fractured media conductivity, the 3-D model formulation required assessment of the rock capacity characteristics, such as fractured porosity or/and specific yield. For example, Table 1 shows the values of fractured porosity obtained by the nitrate balance method. The method is based on analysis of the spatial distribution of nitrate-ion plumes from Lake Karachai and Reservoir-17 in rock masses under these lakes. The changes of the fracture porosity values with depth were assumed to be proportional to the amount of fractures observed by core investigations. Figs. 10 and 11 illustrate the information obtained by the nitrate balance method. The results of calculation of rock capacity characteristics, using different methods, are presented in Table 2. Obviously, the fracture porosity corresponds to the specific yield, so one can

use any of the parameters in the hydrodynamic model or the model of the neutral component (nitrate) transport. Also, the most reliable information on parameter distribution is provided by telephotometry, which makes it possible to find features of fracturing distribution, as well as to define hydraulic conductivity changes with depth (Fig. 8).

Thus, the 3-D scheme of the modeled domain was determined. According to the scheme, each zone of the 2-D model was presented as a multi-layered prism in vertical cut. This scheme was also justified by model simulation of nitrate-ion migration in ground water. The comparison of the configuration of the contaminant plume shown in isolines of nitrate concentration obtained by 3-D modeling and from the monitoring data show good concordance. It permits us to consider the scheme as acceptable for the current stage of 3-D model development.

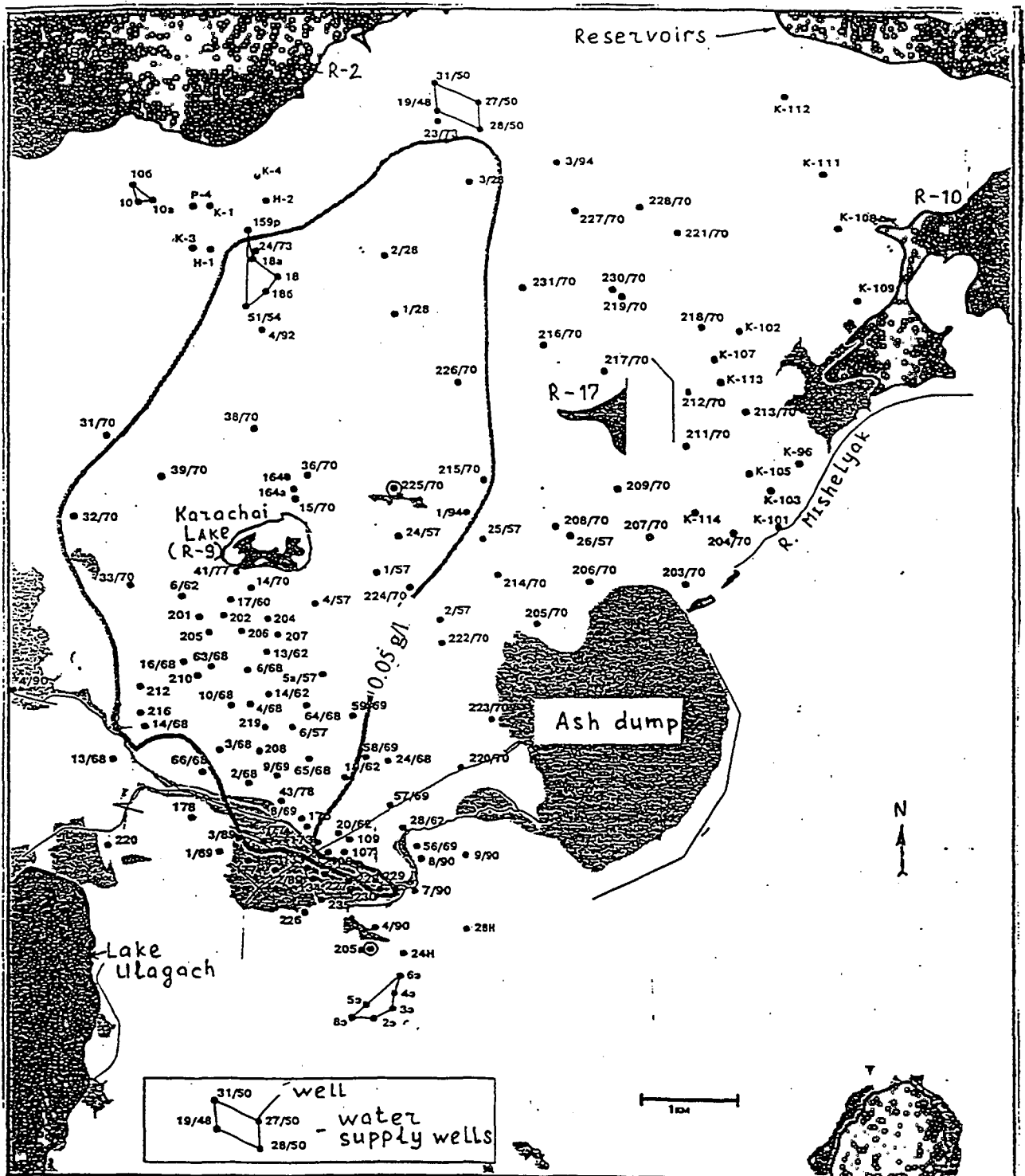

Fig. 1 Configuration of the contaminant plume ( shown by isoline of nitrate-ion concentration equals to 0.05 g/liter). Dots are well location, its number is given nearby.

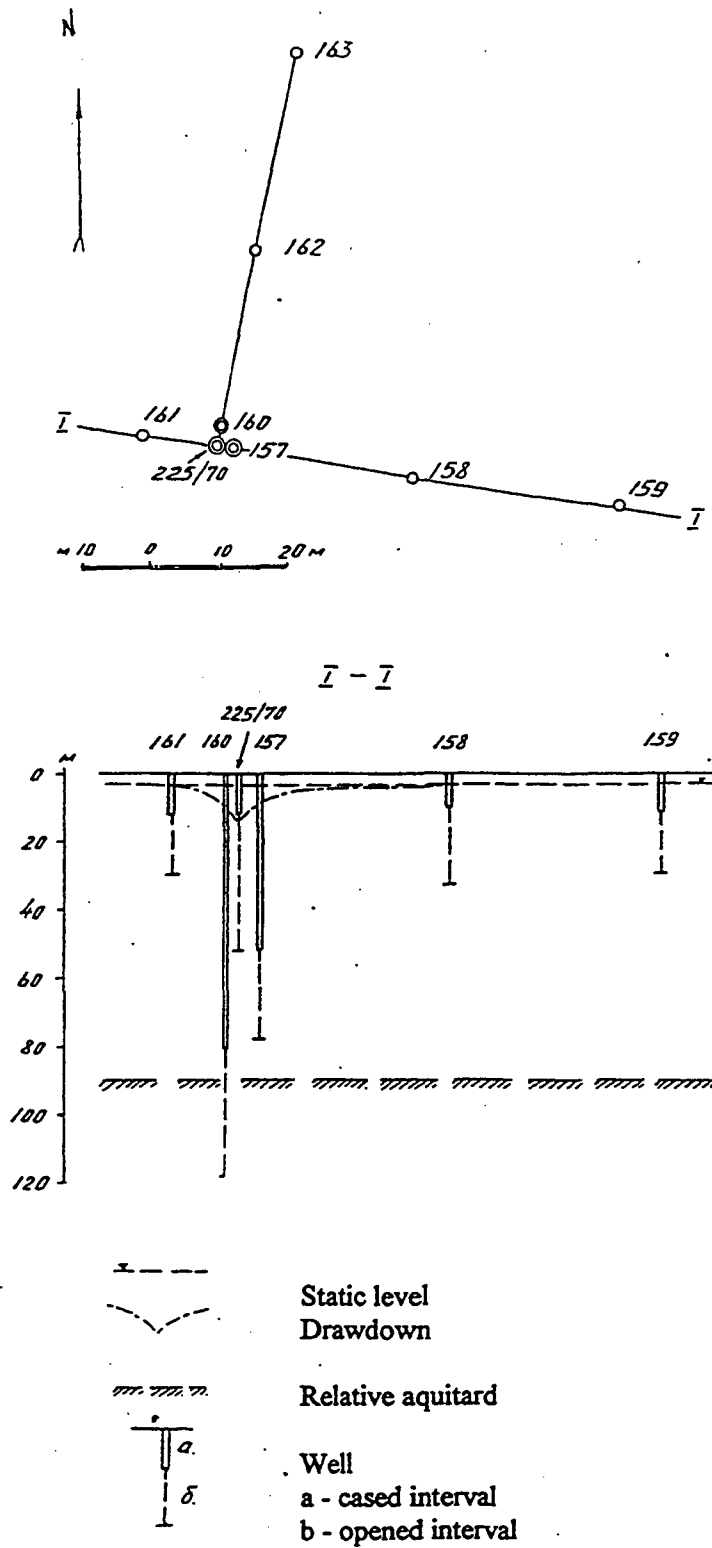

Fig.2. Scheme of cluster pumping test.

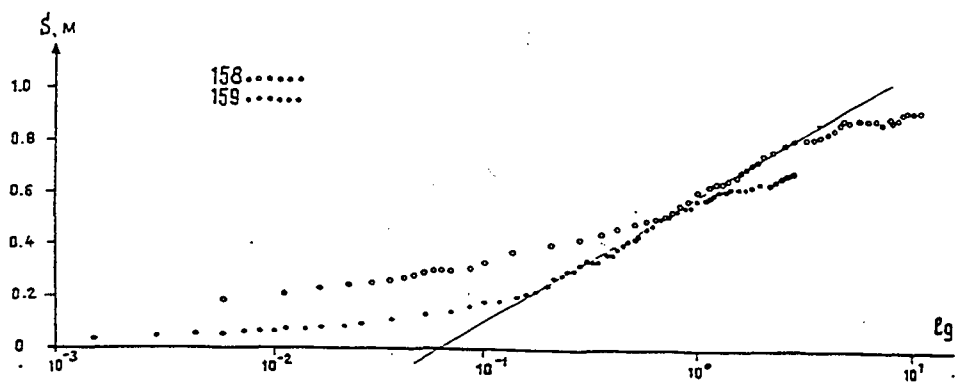
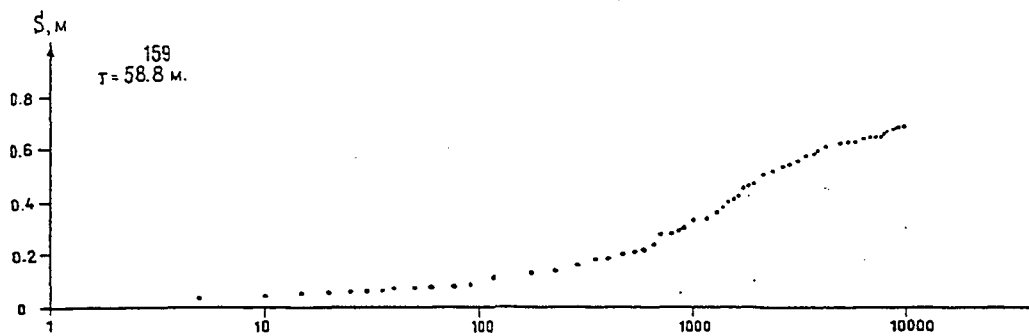
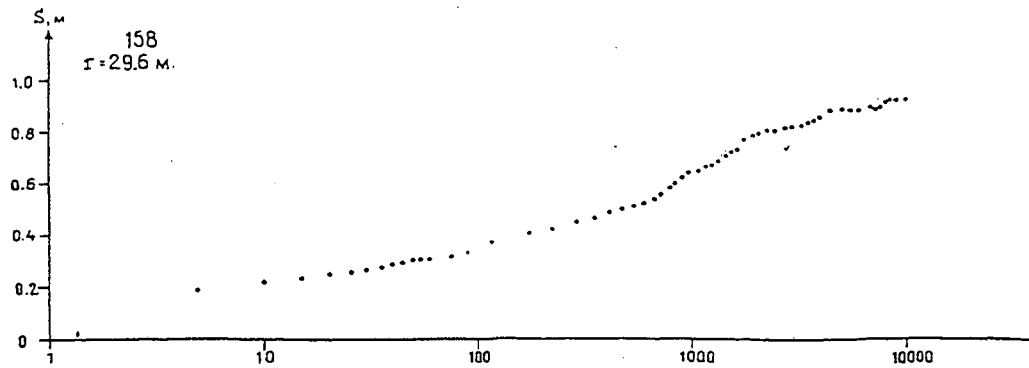

Fig.3. Drawdown in the observation wells (line 1) during pumping-out from well 225/70

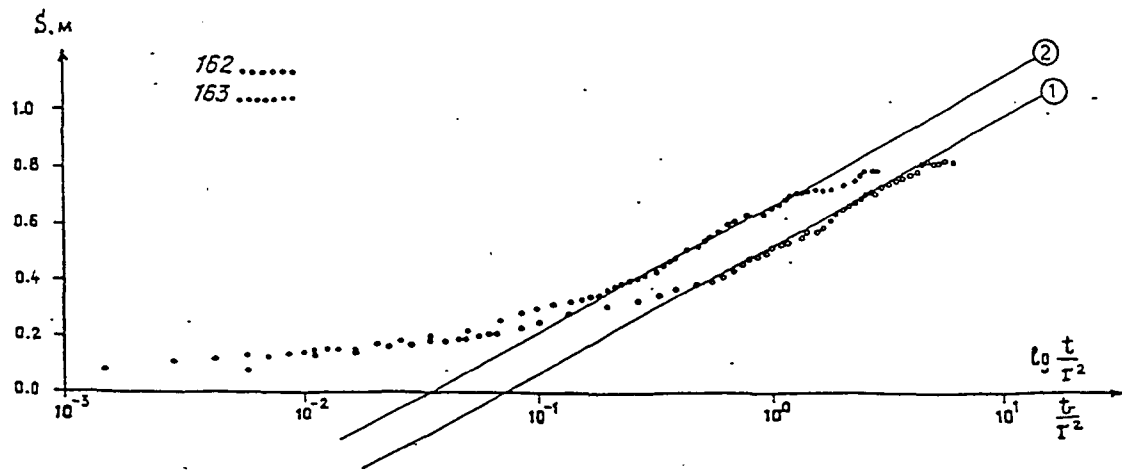
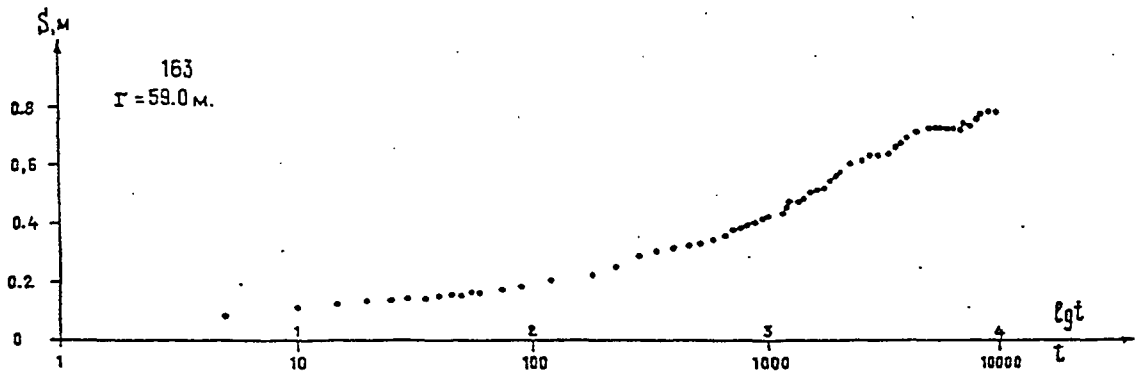
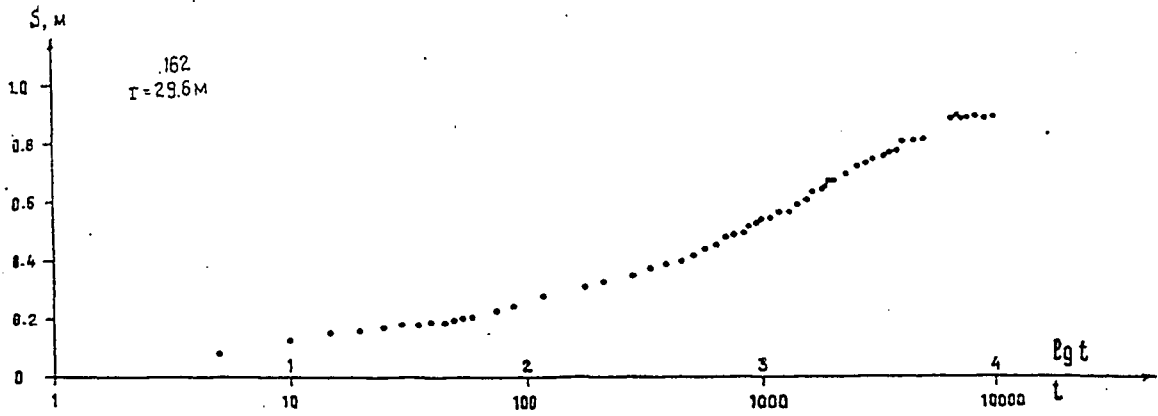

Fig.4. Drawdown in the observation wells (line 2) during pumping-out form well 225/70

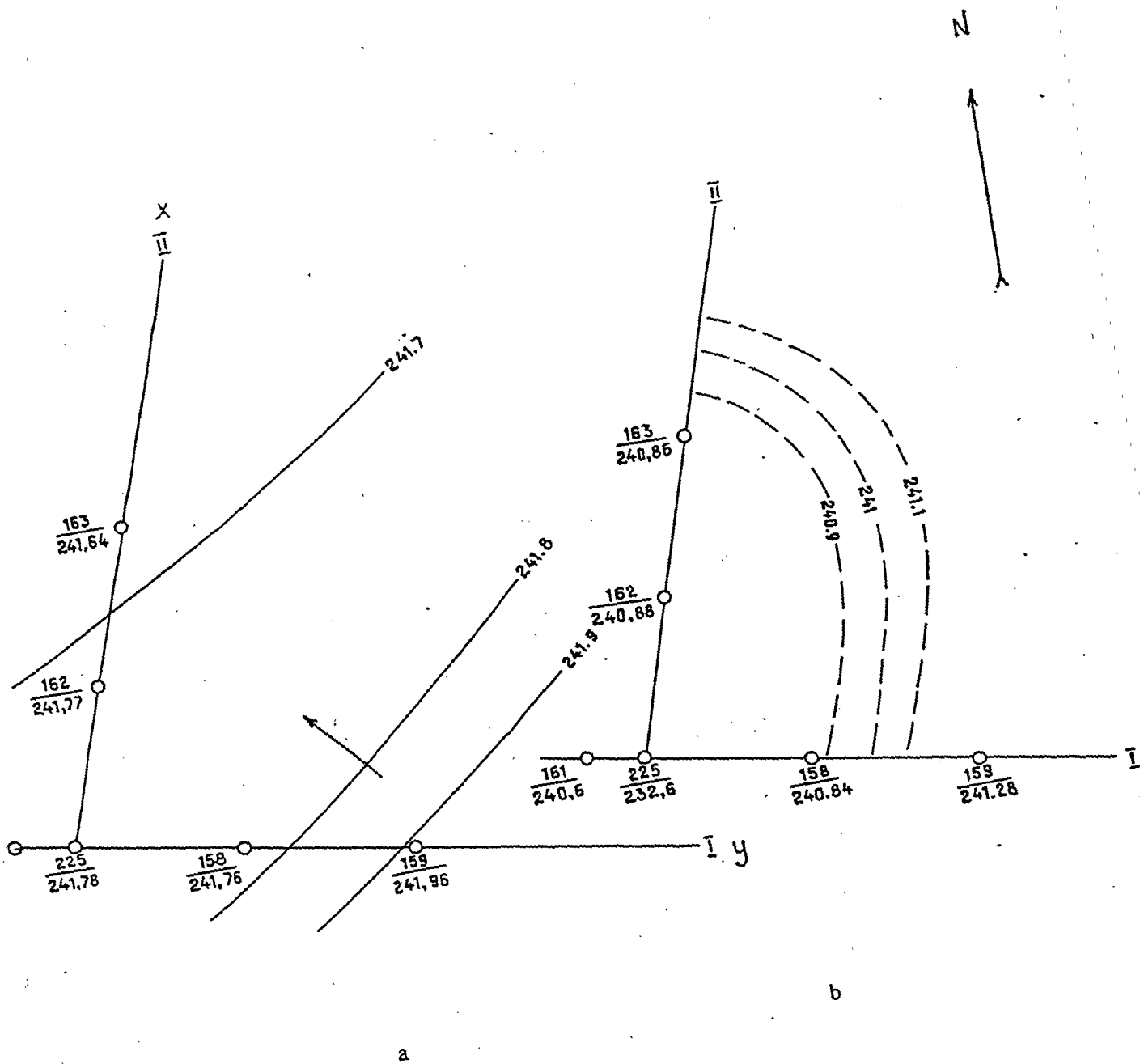

Figure 5. Scheme of water-table contours  
 a) in natural conditions  
 b) depression at the end of pumping test

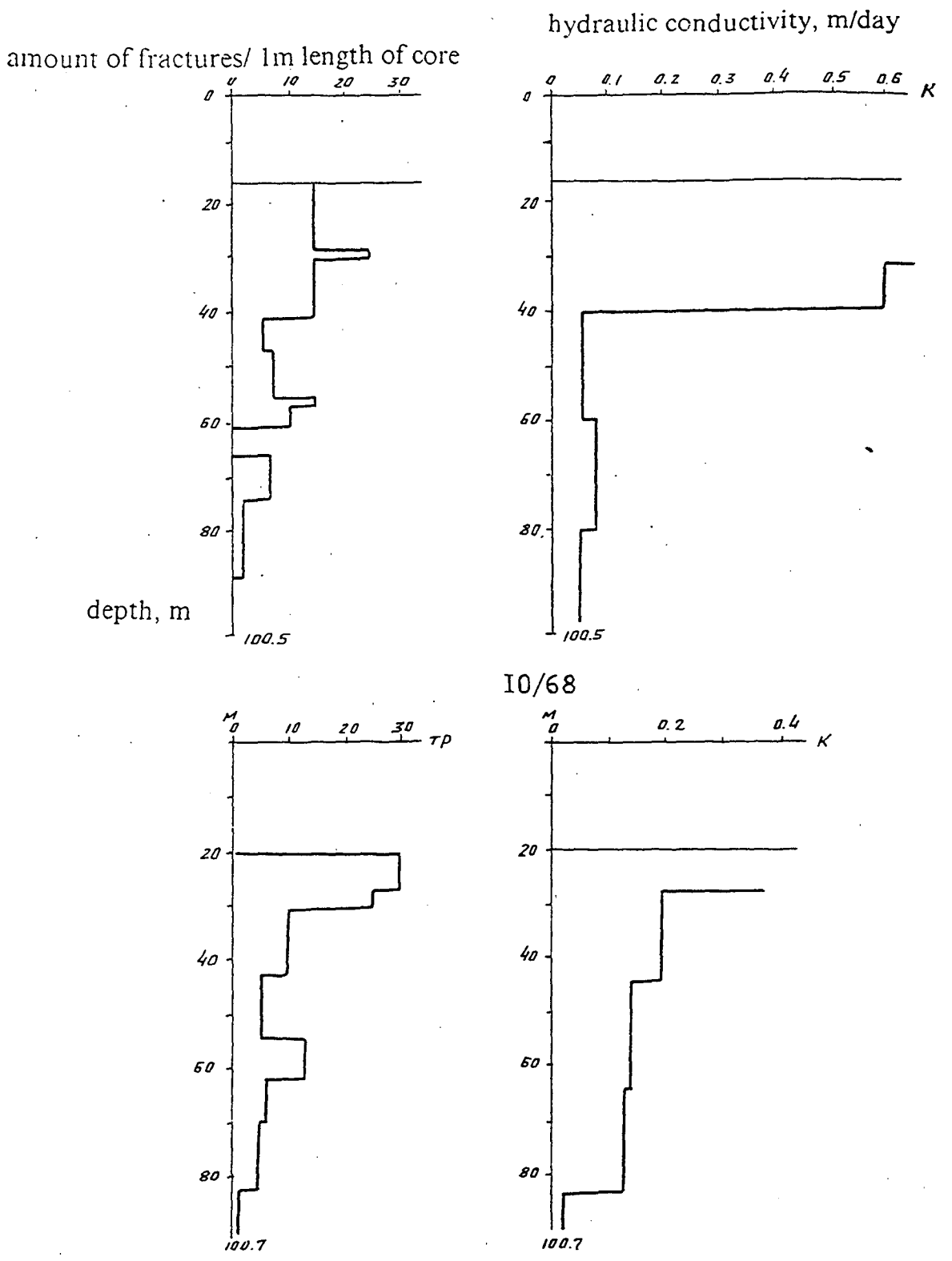

Fig. 6. Changes of fractures amount and hidraulic conductivity with depth (the wells are situated in the southern part of the contaminant plume)



31/70

amount of fractures/ 1m length of core

hydraulic conductivity, m/day

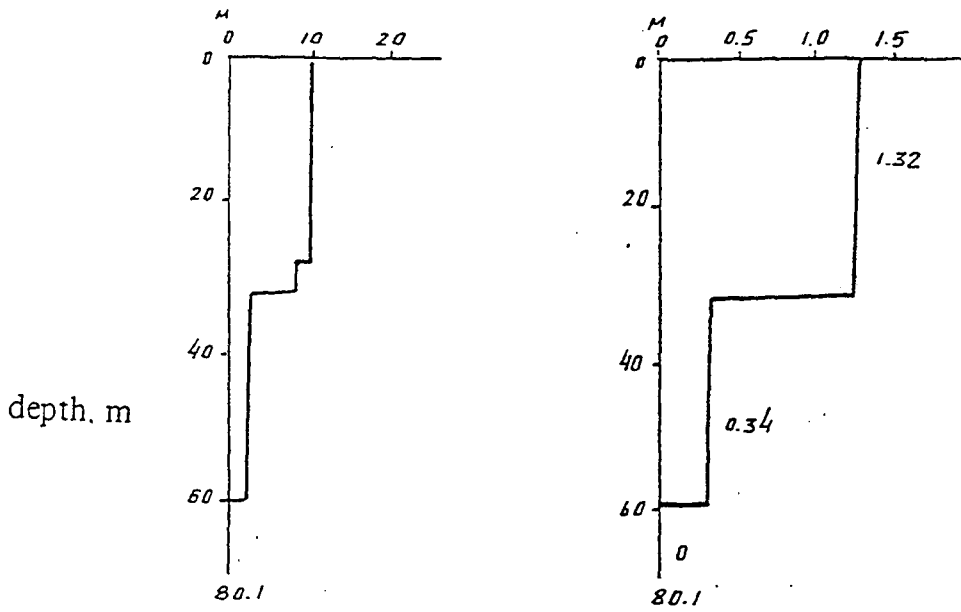

38/70

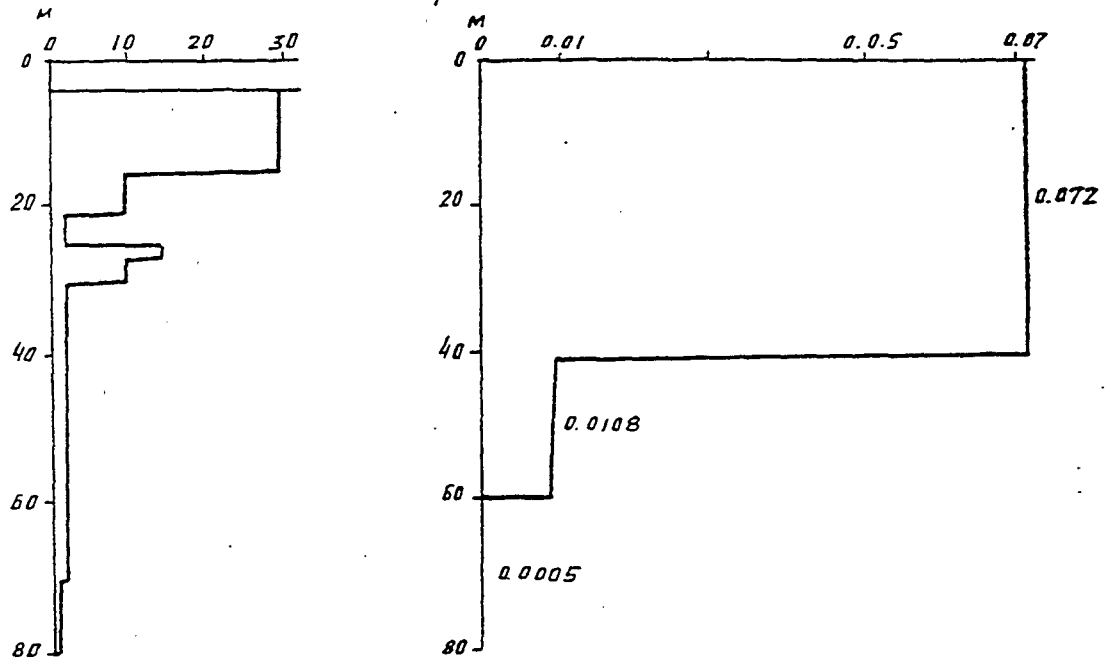

Fig.7. Changes of fractures amount and hidraulic conductivity with depth (the wells are situated in the northern part of the contaminant plume)

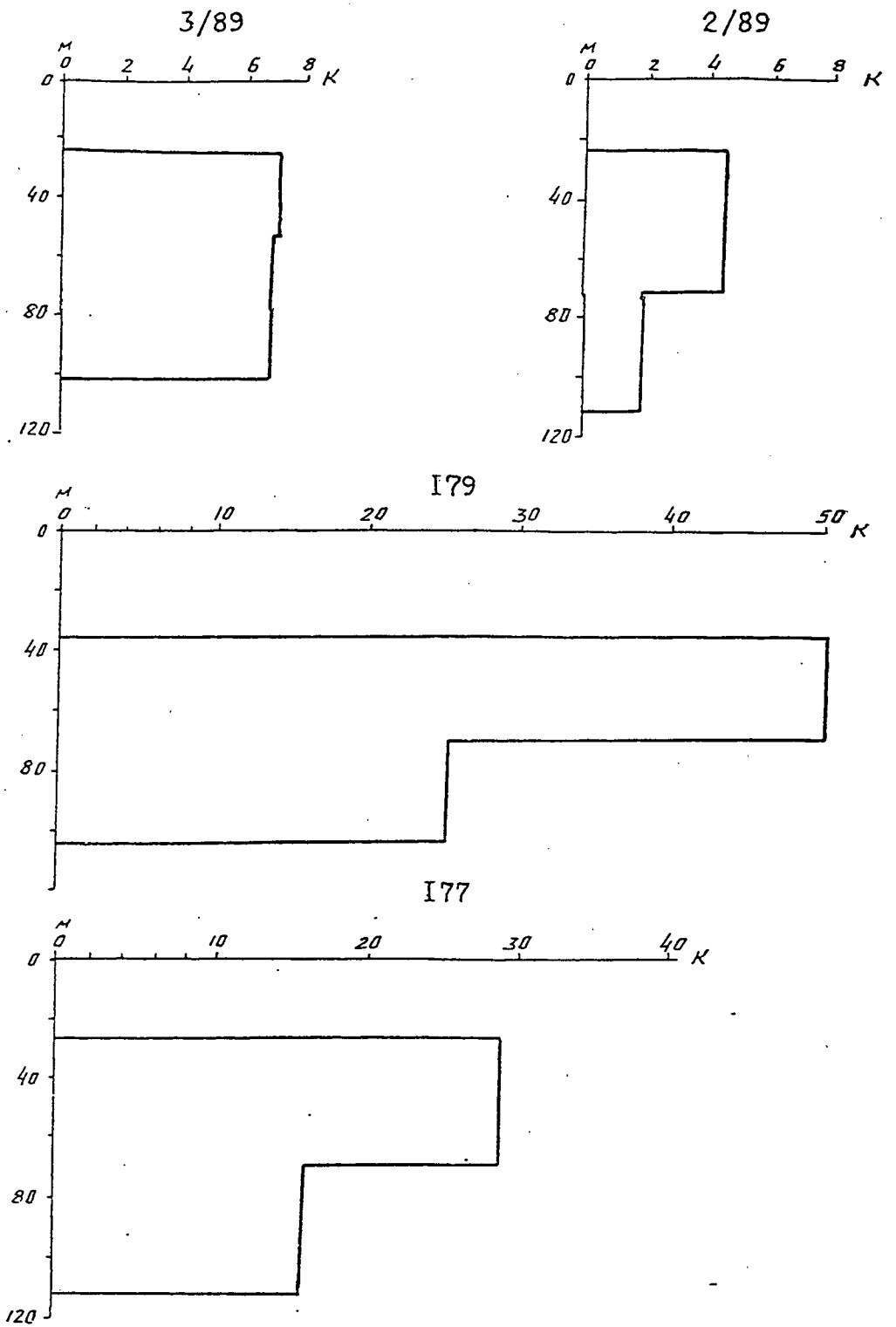

Fig.8. Vertical distribution of hydraulic conductivity values calculated by processing telephotometry data.

amount of fractures/ 1m length of core

porosity, %

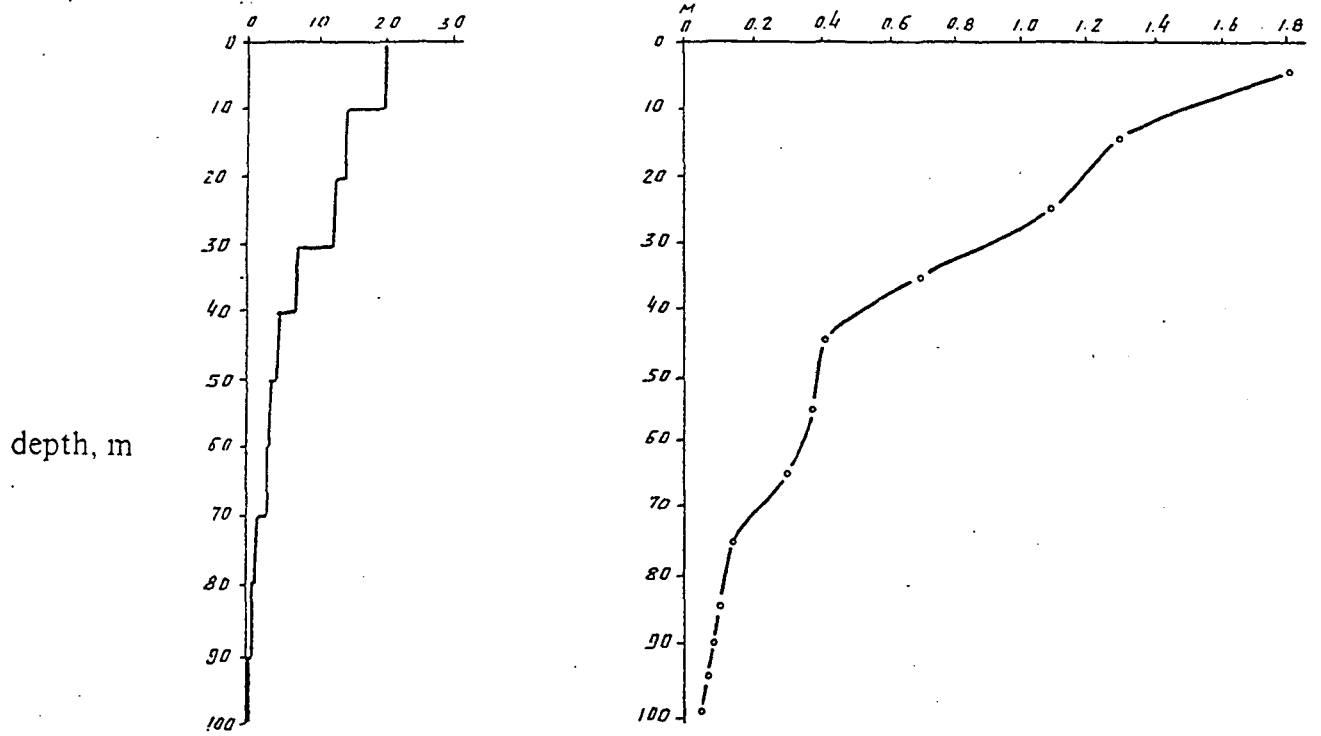
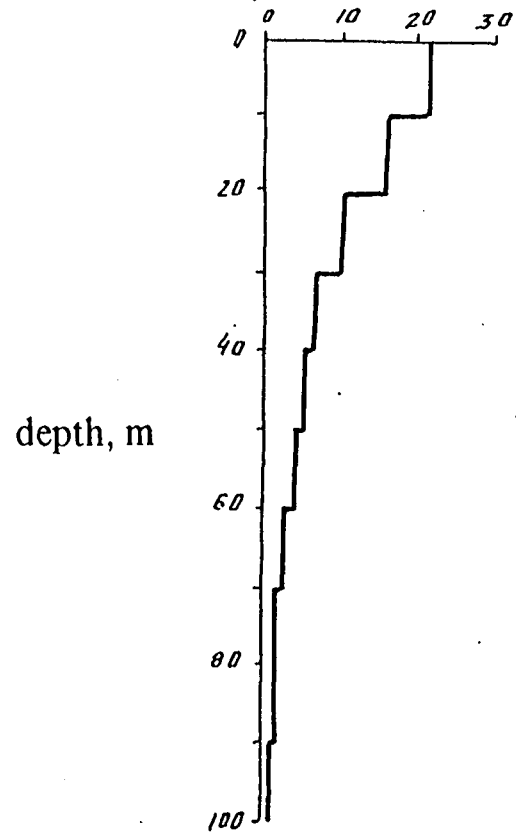

Fig.10. Vertical distribution of the average values of fractures amount and porosity (for 17 wells situated in the southern part of the contaminant plume).

amount of fractures/ 1m length of core



porosity, %

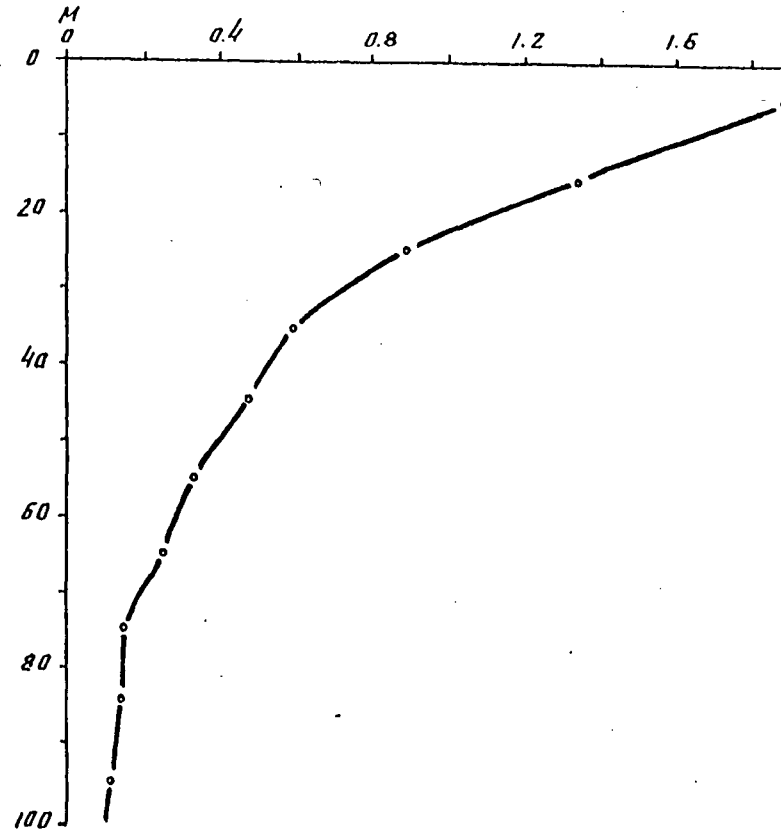

Fig.11. Vertical distribution of the average values of fractures amount and porosity (for 12 wells situated in the northern part of the contaminant plume).

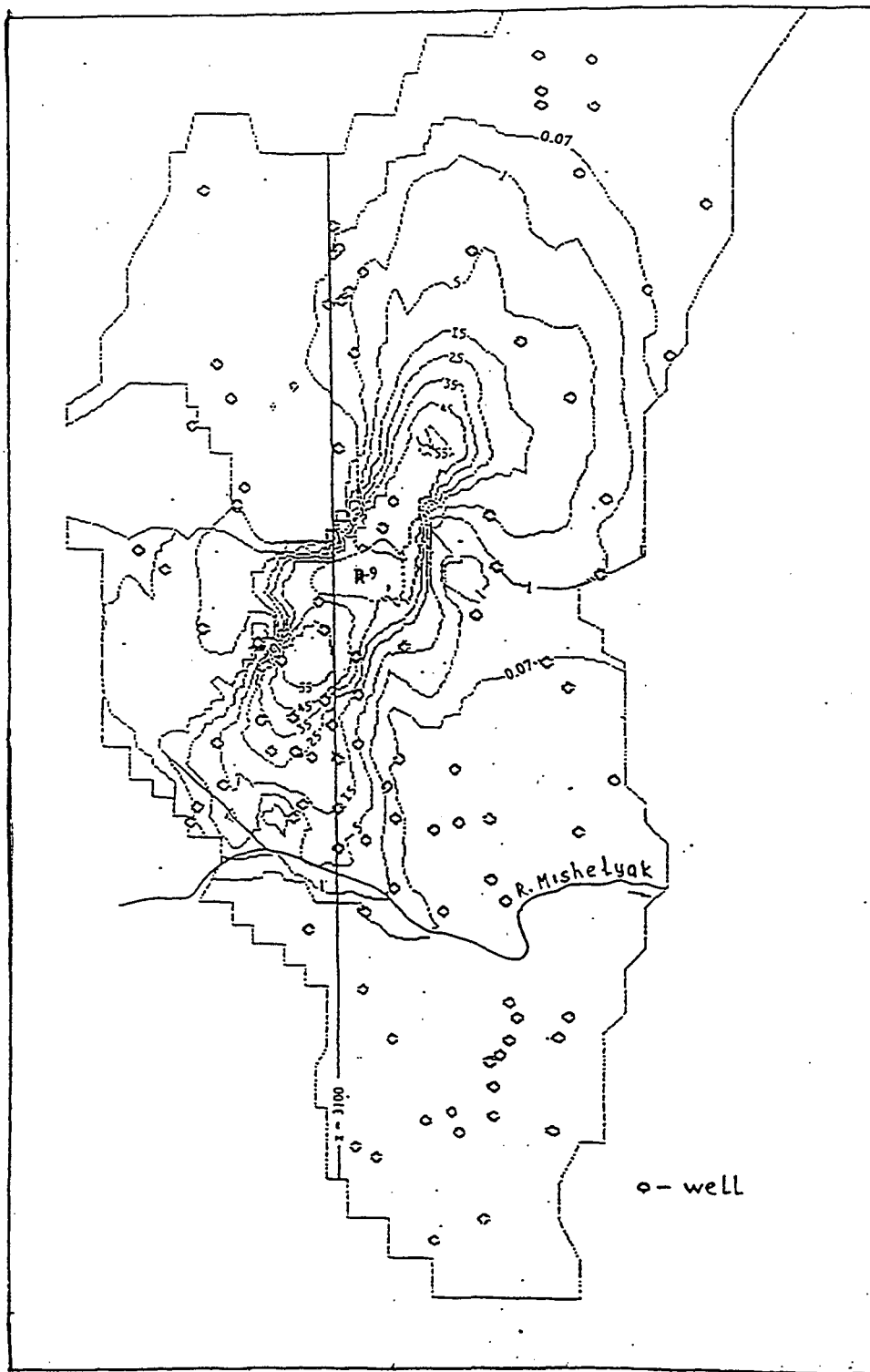

Fig. 12. Areal distribution of nitrate-ion in ground water obtained by 3-D model simulation. Nitrate-ion concentrations is presented in g/liter. Dots are well location.

**Table 1**

**Specific storage values calculated by processing of ground water contamination data (balance method)**

Specific storage value for depth interval (m)															
Area	0 - 10	10 - 20	20 - 30	30 - 40	40 - 50	50 - 60	60 - 70	70 - 80	80 - 90	90 - 100	100 - 110	110 - 120	120 - 140	140 - 170	170 - 180
South of Karachai	0.018	0.013	0.011	0.0069	0.0043	0.0039	0.0034	0.0017	0.0011	0.00069					
North of Karachai	0.019	0.014	0.0095	0.006	0.0047	0.0034	0.0026	0.0017	0.0017	0.0013					
Adjacent to Reservoir-17	0.024	0.022	0.02	0.017	0.015	0.01	0.009	0.008	0.007	0.007	0.0017	0.0026	0.0026	0.0017	0.0002

Table 2

Average depth-weighted values of calculated parameters

Calculation method	Fractured porosity	Specific yield
Balance method (lake Karachai site)	$6.4 \cdot 10^{-3}$	
Balance method (Reservoir 17 site)	$8.5 \cdot 10^{-3}$	
Telephotometry	$9.3 \cdot 10^{-3}$ $3.5 \cdot 10^{-3}$	
Monitoring data processing (lake Karachai site)		$5.5 \cdot 10^{-3}$
Monitoring data processing (south of lake Karachai)		$4.7 \cdot 10^{-3}$
Cluster pumping tests interpretation Production well: 225/70 164 172 7/48		$9.8 \cdot 10^{-3}$ $3.4 \cdot 10^{-3}$ $5.3 \cdot 10^{-3}$ $3.3 \cdot 10^{-3}$
Range of calculated values	$3.5 \cdot 10^{-3} - 9.3 \cdot 10^{-3}$	$3.3 \cdot 10^{-3} - 9.8 \cdot 10^{-3}$

**Geotechnical monitoring of underground water  
deep injection wells and basins of liquid radioactive  
waste sites of Siberian Chemical Combine**

**Zubkov A. A.**

Siberian Group of Chemical Enterprises

July 8 - 9, 1997

**JOINT RUSSIAN-AMERICAN HYDROGEOLOGY SEMINAR**

Russian - American Center for Contaminants Transport Studies  
Ernest Orlando Lawrence Berkeley National Laboratory  
Berkeley, California 94720



The main goals of geotechnical monitoring at injection waste sites of the Siberian Chemical Combine are: monitoring of safety of injection processes and surface reservoirs containing nuclear waste; providing field information for injected plume body mapping; and risk assessment for potential population radioactive exposure due to injection. The network of monitoring wells (Fig. 1, 2) provides the basis for monitoring. This network allows monitoring of ground water in all aquifers, including two injection aquifers (N1 and N2) and the overlying hydrogeological system. The information obtained by using this network and collected in a database includes geochemical sampling of ground water, geophysical well logging, and ground water level measurements. Surface electrical and radar measurements are used for monitoring around the surface reservoirs containing nuclear waste. This type of monitoring has allowed us to find the places of local ground water contamination of the upper aquifer due to leakage, and to estimate the present condition of the bottom clay barriers of the surface reservoirs.

The results of monitoring at the LLW site 18 (Fig. 1) are given in this presentation. Fig 3 shows the geological cross section for the area of the injection site. Fig 4 shows the latest map of the ground water level in injection aquifer N2. Fig 4 also shows the current spatial distribution of the front of injected wastes, the transient zone of contamination due to injection into ground water, the internal contaminated zone, and the zone of natural ground water composition. Analyses of the results of geochemical sampling show the consistent pattern of ground water chemical composition changes. The changes depend on distance from the front of the injected wastes. Increase of organic C is observed in the internal zone. The ground water acidity increases far from the front part of the transient zone, and it decreases close to the front. The chemical composition of the transient zone is characterized by the increase of  $\text{SO}_4$ , Cl, Ca, Mg, and Fe, due to processes of water-rock exchange. This zone also contains some specific components from injected wastes. The inner part of the contamination plume behind the injection front has, essentially, the chemical composition of injected the wastes. Delay of radioactive elements due to the sorption capability of the geologic medium, in comparison with the neutral component, is shown in Fig 5. It was found that, on average, the velocity of radioactive element

spreading in the ground water is 1.5 - 3 orders of magnitude less than the velocity of the neutral component.

The injection polygon at Tomsk-7 showing the two injection regions and a cross-section of the layered injection scheme for low, intermediate and high-level liquid waste.

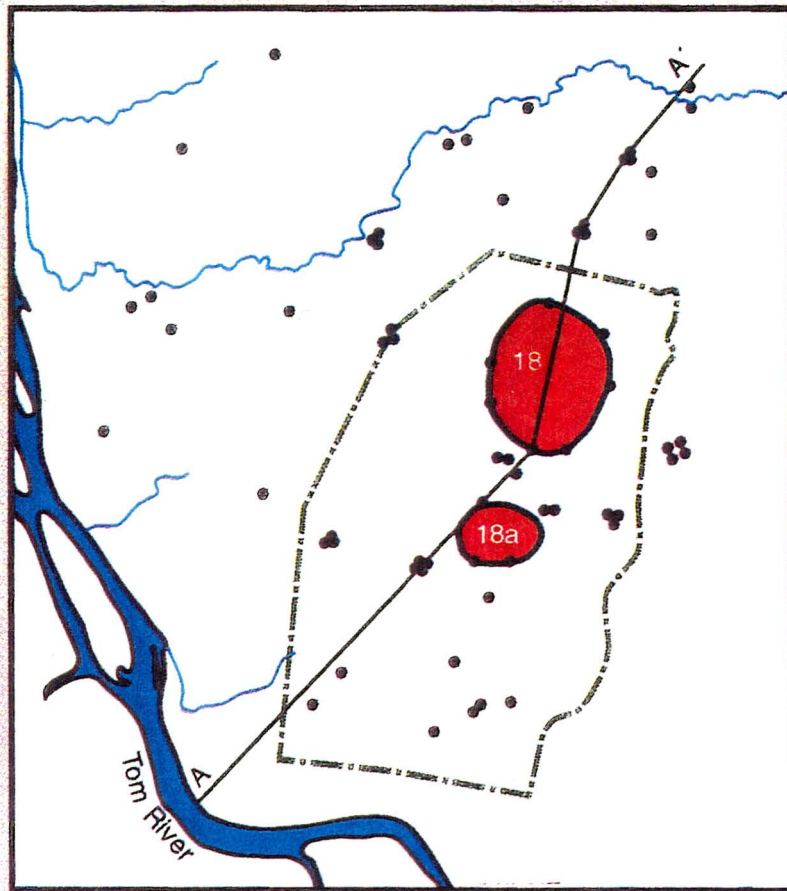

- Region of Injection
- Boundary of Polygon
- Observation Wells
- II Stratigraphic Index

**Cross-Section A-A' – Tomsk Well-Injection**

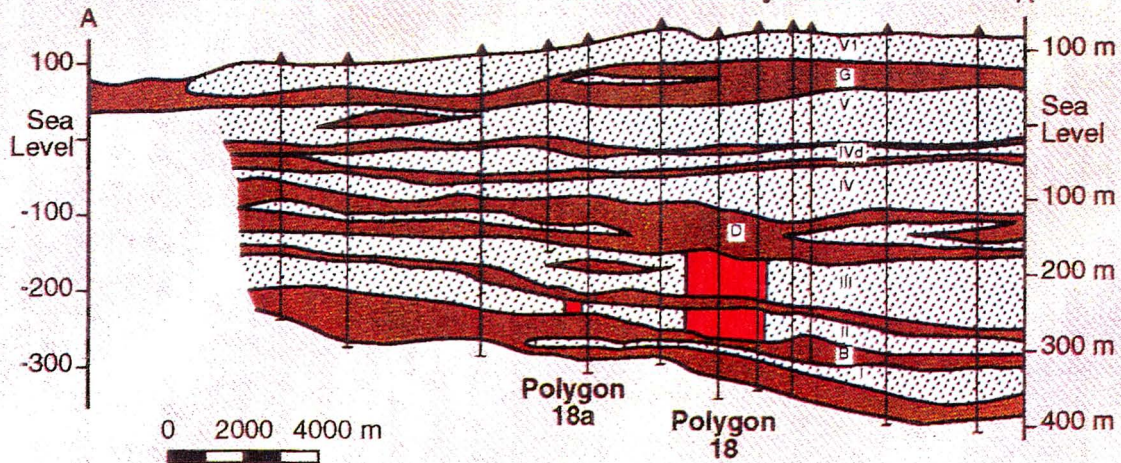

SG95100288.1C



Рис. 6 . Распространение РАО в пластах-коллекторах установок захоронения, Томск



а) низкоактивные отходы; б) среднеактивные отходы  
 1, 2, 3 - соответственно нагнетательная; наблюдательная  
 и ликвидированная скважины; 4 - граница установки;  
 5 - контур отходов

# Геотехнологический разрез по линии А - А

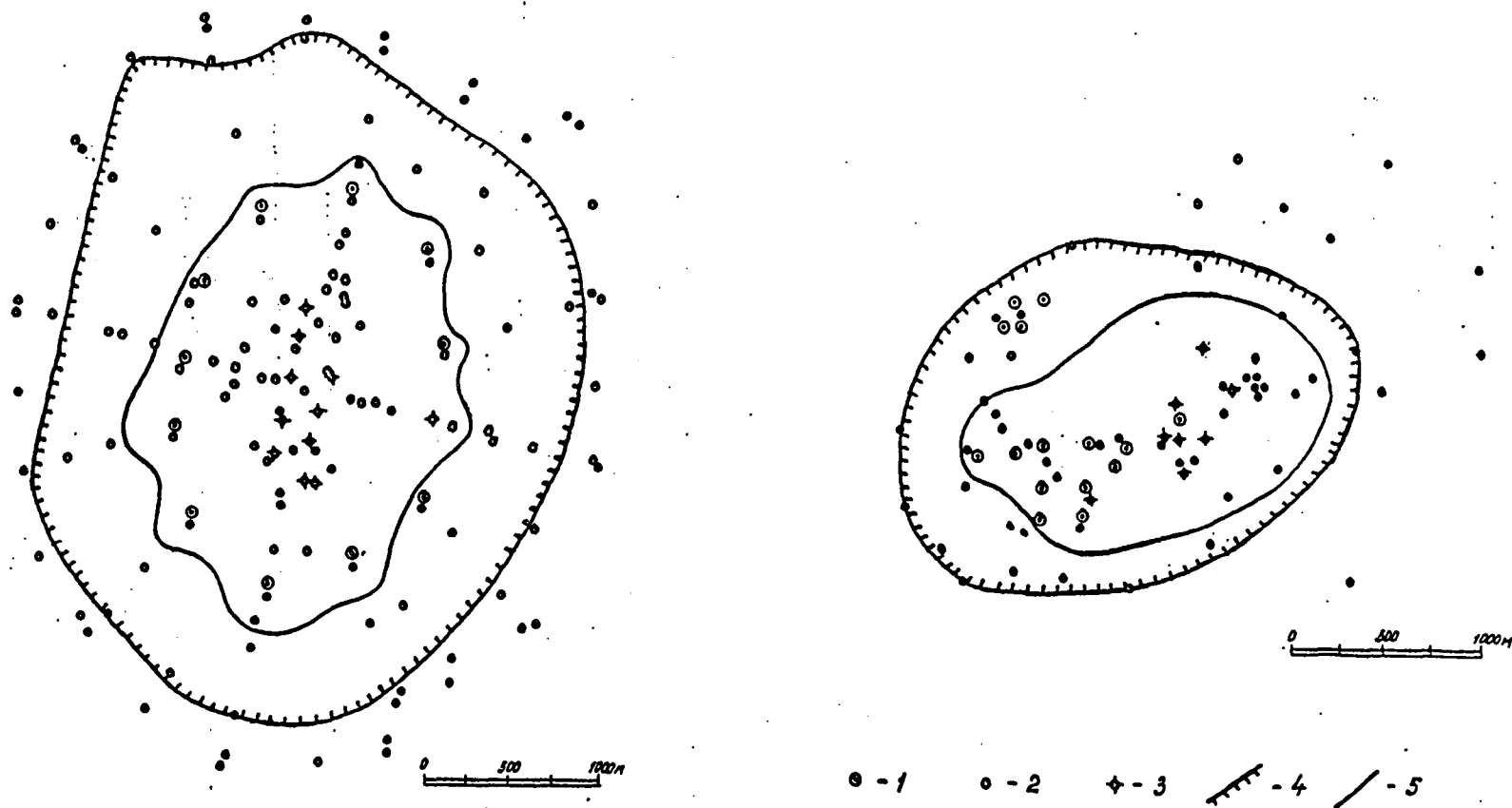
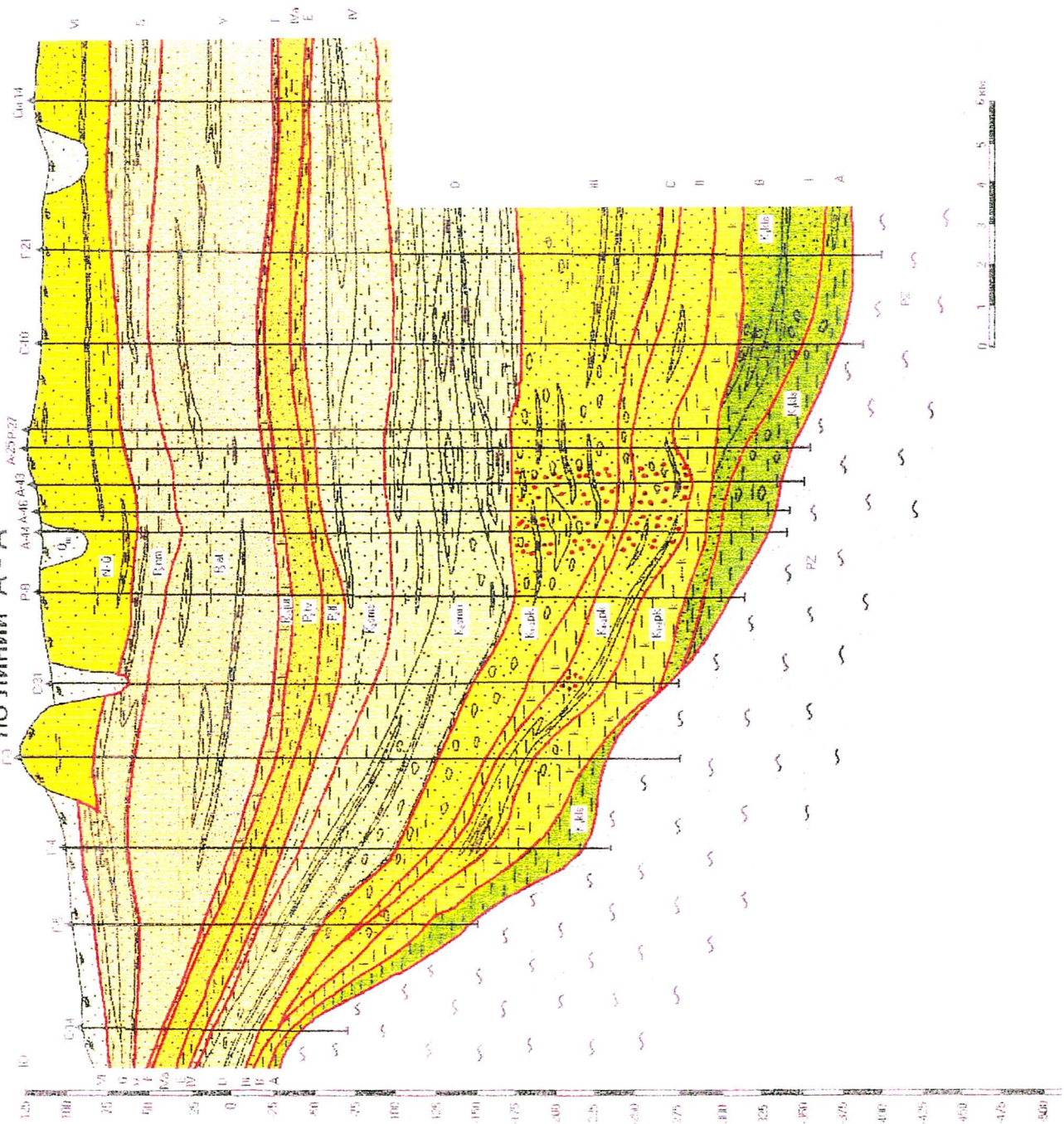
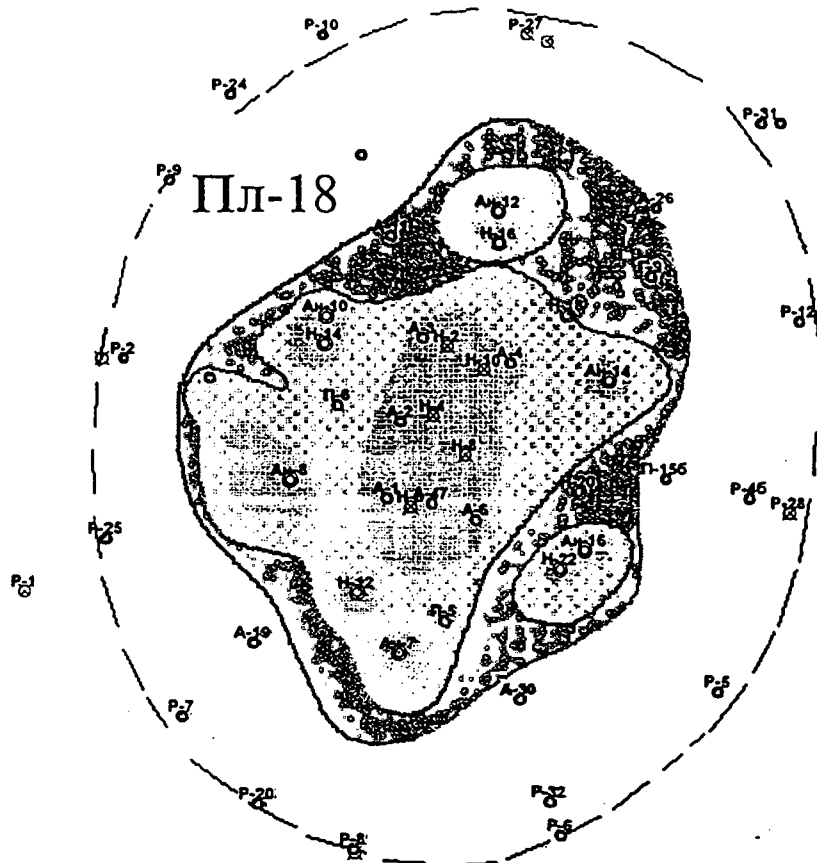



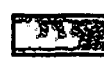



**Условные обозначения:**

-  - Участки измененных по хим. составу вод в результате гидродинамического фактора
-  - Участки слабозагрязненных вод
-  - Участки сильнозагрязненных вод

П-16

**Типы скважин:**

-  - Ликвидированные
-  - Наблюдательные II гор.
-  - Нагнетательные II гор. (действующие)
-  - Нагнетательные II гор. (недействующие)



Рис. 3.17. Распространение участков загрязнения подземных вод II горизонта пл.18.



Рис. 2.7. Схема гидроизопьез II горизонта площадок 18, 18а на 16.07.97г в период максимального развития репрессивного купола на площадке 18.

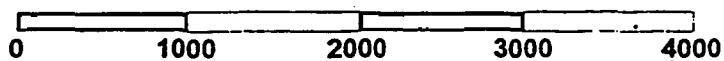

Рис. 3.9. Изменение рН подземных вод по скважинам А-1, 3, 44, 47 при нарастании сульфатно-хлоридных изменений состава в передовых частях поля фильтрага отходов.



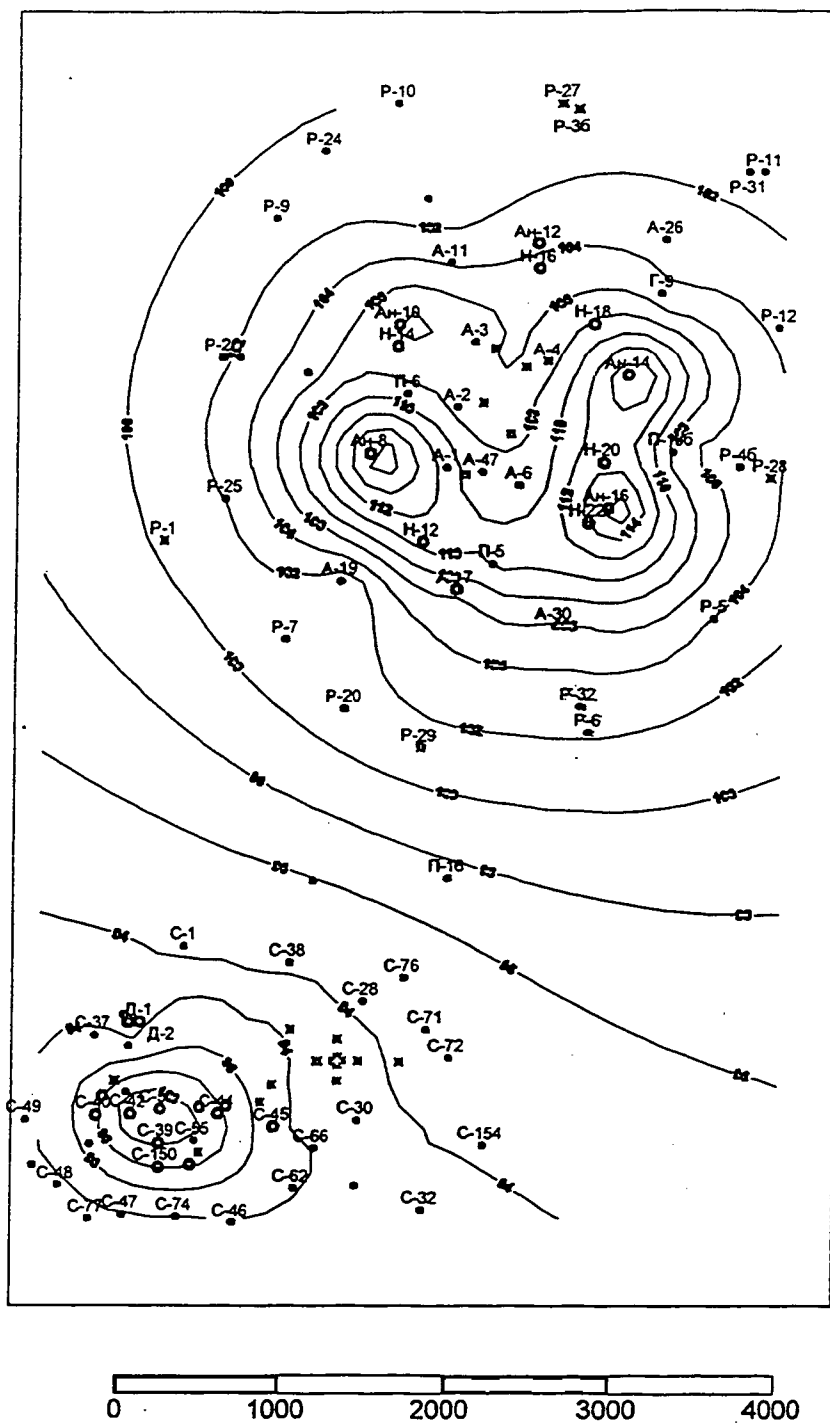

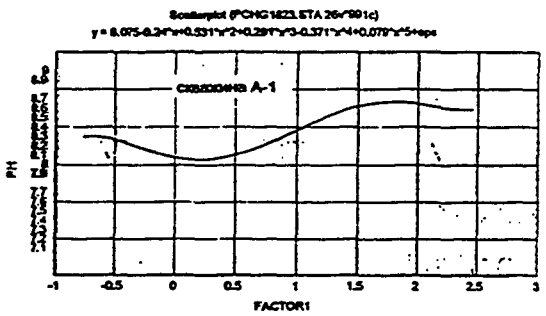
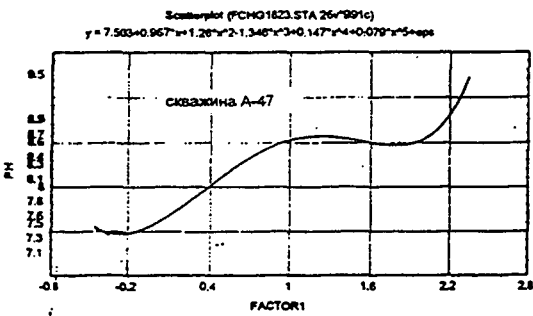
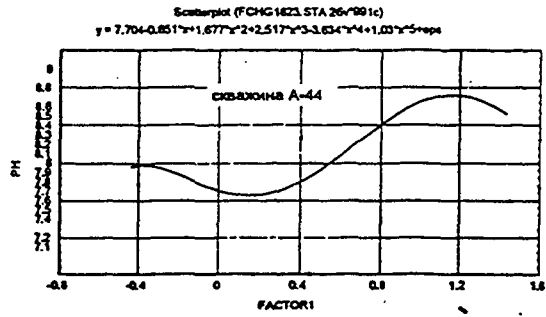
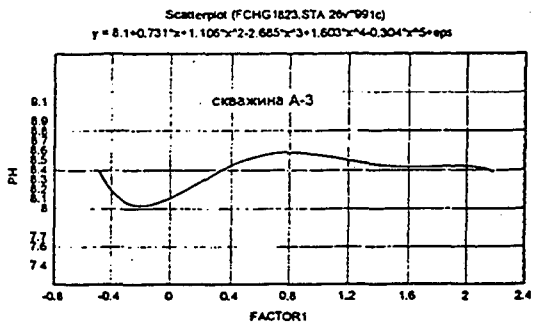
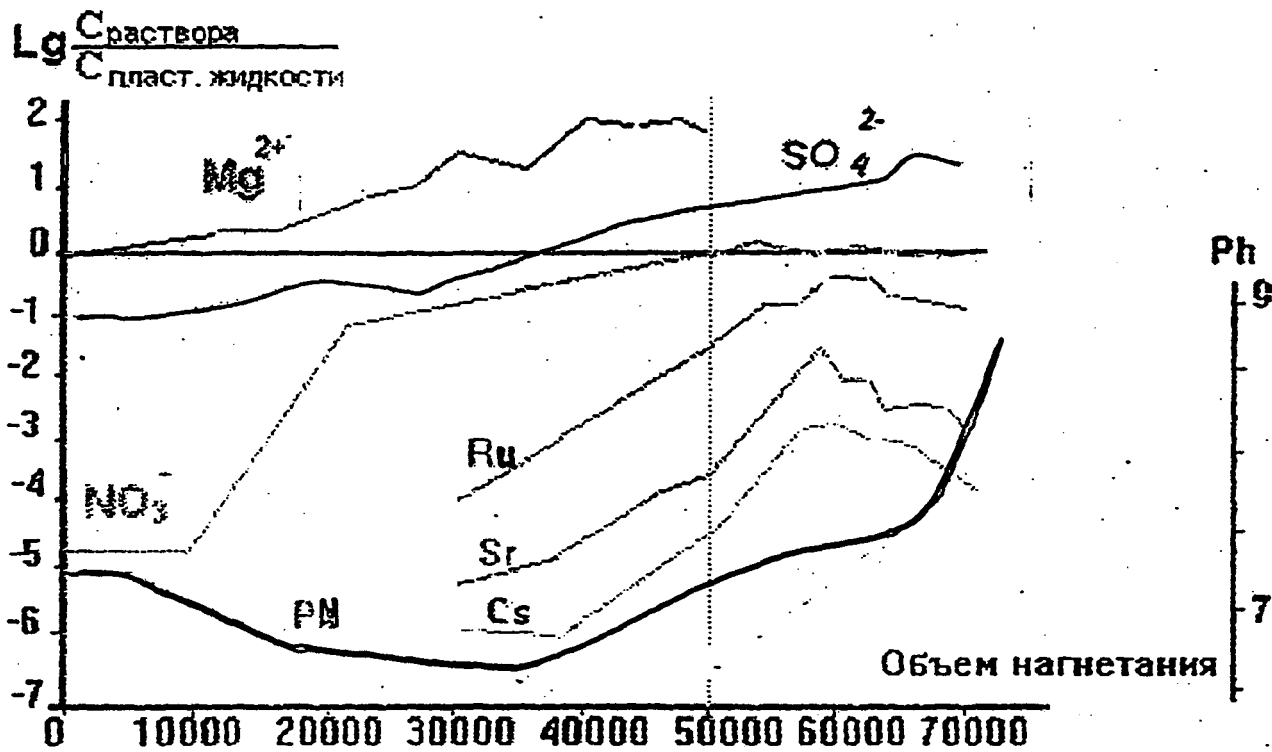

Рис.3.15. План температурного поля III эксплуатационного горизонта площадки 18.



**Study of radionuclides transport in deep-well  
injection of liquid radioactive wastes in Russia**

**Rybalchenko A. I.**  
VNIPIROMTEKHNLOGII, MINATOM of Russian Federation

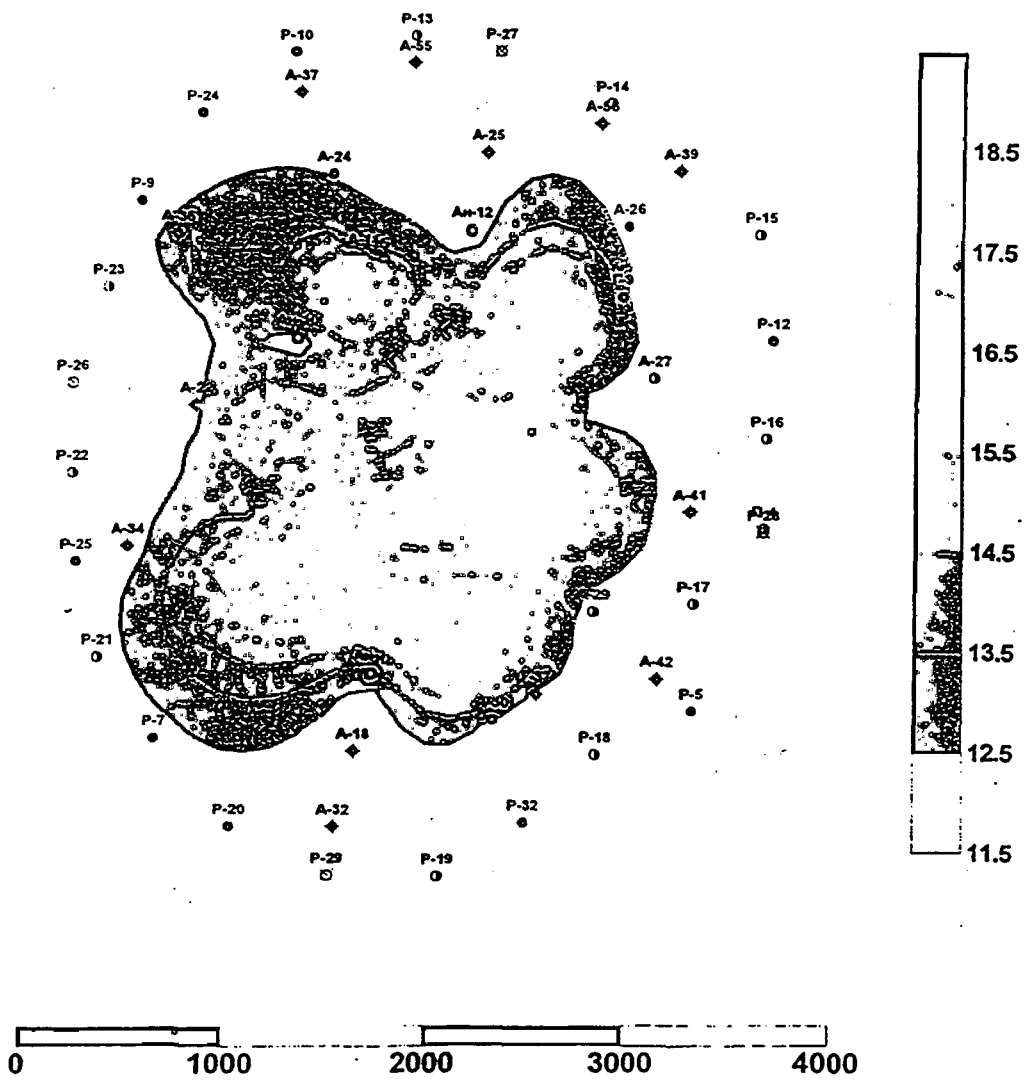
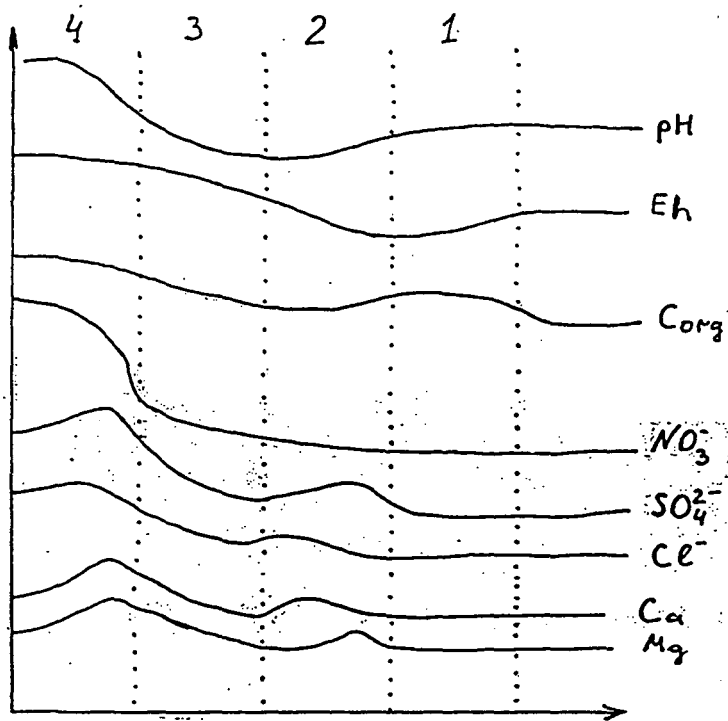
July 8 - 9, 1997

**JOINT RUSSIAN-AMERICAN HYDROGEOLOGY SEMINAR**

Russian - American Center for Contaminants Transport Studies  
Ernest Orlando Lawrence Berkeley National Laboratory  
Berkeley, California 94720

The solution of practical problems in the storage and disposal of radioactive wastes and remediation of environment the regions of surface contamination and ground water pollution, is based on the results of investigation of the geological formation as a medium of radioactive contaminant transport, including radionuclides migration with ground waters in porous rocks. Investigations include preparation of process theoretical models, laboratory study to verify models and parameters, and experiments under natural conditions in the regions of artificially caused and existing ground water pollution. Results of protracted observations and investigations in the regions of deep-well injection of liquid radwaste are of great interest. In Russia, deep-well injection has been conducted since 1963 - in Tomsk (Siberian Chemical Combine), Krasnojarsk (Mining and Chemical Combine), and Dimitrovgrad (Research Institute of Atomic Reactor). The total volume of disposed wastes exceeds 40 million. cubic m., the volume of the geological medium occupied by radioactive wastes is nearly 250 million. cubic m., observations are conducted through several hundred wells, and include determination of ground water levels (piezometric surface), ground water analysis (composition), and geophysical characteristics.

As the information obtained is voluminous it can not be given in this report, so the present paper gives the conclusions and observations considered reliable. Proposals for further investigation of deep-well injection sites of Russia are discussed in connection with their preparation for shut-down and according to the assessment of impact on the environment of disposal sites for long periods of time. The results of the investigations may be of interest for solution of similar problems of predicting the extent of environment contamination and its remediation.

The paper does not give site descriptions as they have been presented earlier [1,2].

The following model of the geological medium at the injection sites is accepted :

The reservoir horizon with porous rocks is isolated from above and from below by strata of relatively impermeable clayey rock. The upper part of geological formation includes a few permeable and confining layers, isolating the reservoir horizon from shallow ground waters and the surface. Within the area of possible influence of injection, the connection of the reservoir horizon with the upper layers is absent, including vertically permeable tectonic zones. The reservoir horizon is non homogeneous with respect to its filtration properties. It consists of zones and layers of different permeability, separated by zones and layers of lesser permeability.

During injection, the wastes move from the borehole through the well screen into the reservoir, where they fill the pore space, displacing formation waters and partly mixing with them. Thus a zone of mixing at the border of wastes-rock-water is formed. As a result, a "pool" of wastes appears in the reservoir.

After injection is stopped, wastes are displaced and migrate under the natural movement of ground waters. The main factors defining the distribution and migration of waste components are:

- (i) natural characteristics of the reservoir horizon and the rocks forming it,
- (ii) conditions of waste injection through the well-screen into the reservoir horizon,
- (iii) hydrogeological conditions of the reservoir and the region of the disposal,
- (iv) geochemical interaction between waste components, rocks, and water.

The dependence of the waste's distribution scale and volumes of injected wastes is obvious, and is not discussed in detail.

The major characteristics of the reservoir horizon defining the scale of waste distribution are the effective thickness - the sum of the most permeable layers of the reservoir horizon and effective porosity - the part of the reservoir horizon's pore space filled with wastes. "Specific capacity" of the reservoir horizon is an integral characteristic; it characterizes the volume of wastes per square meter of horizon area: the product effective thickness ( $m$ ) and porosity ( $n$ ):

$$E = m \times n.$$

The magnitude of Specific Capacity depends on many factors, so it is convenient to use it for comparative assessment. For deep storage of liquid radwaste in Tomsk and Krasnojarsk, the reservoir horizon, which consist of sand and poorly cemented sandstone, the specific capacity is in the range of 3-6 m., and for deep storage in Dimitrovograd with a limestone reservoir horizon dominated fracture porosity, the specific capacity less than 1 m.

According to observations in operation of deep storage in Tomsk and Krasnojarsk (gamma-logging) it was found that the effective thickness of horizons is 2-3 times lower than predicted, using the data of the preliminary study.

Fig.1 gives data of geophysical investigations of one of the deep storage boreholes in Krasnojarsk. The effective thickness is 30 m., according to resistivity logging and sampling (A,B). A similar thickness was found from study of the injection well, which disposes in 50 m.(C-hydrological logging, D-radioactive tracer).

Gamma-logging and temperature-logging data show the real disposition of wastes (E, F, G, H). The effective thickness of horizons is 10m. The effective thickness of the layers and distribution of intervals containing wastes depend on the conditions of waste injection: the state of the screened zone of the well and the pressure of injection. Pore clogging of permeable intervals of the horizons causes redistribution of waste containing intervals. Different permeability of layers of reservoir horizon causes differences in waste advancement. Fig. 2 gives the plot of the growth of the effective thickness of the sandy-clay reservoir horizon in accordance with the volume of injected wastes on observation wells A-4, A-2, A-58 (Krasnojarsk). The variability of the layers' permeability along the horizon is described by the dispersion system on a macroscale. The effect of double porosity appears as the reservoir horizon is filled with wastes: the part of the pore space containing the waste increases over time, causing the growth of specific capacity of the horizon. The porosity of sandy-clay horizons increases two or three times; it is reservoir it is significantly less in the limestone reservoir. The pressure of waste injection influences the intensity of distribution of wastes through the well's receiving intervals. At a specified intensity of injection, the pressure influences waste distribution only to a small degree up

to definite values of the pressure. After these values have been achieved, sharp growth is observed in the waste distribution by some intervals in the formation as a result of hydrofracturing. Use of high injection pressure (higher than hydrofractured pressure) to affect the layer even under condition of short duration, may have unforeseen consequences at Dimitrovgrad; after thrice-repeated hydrofracture a thin bed of cavernous vuggy) rocks began to fill with wastes, leading to rapid distribution of wastes exceeding the predicted distribution.

Low injection pressure does not practically influence vertical filtration nonuniformity. However, when choosing optimal values, it is advisable to conduct flow in the well to obtain an indicator diagram. Vertical migration of waste components through overlying confining beds was not significant, within the limits of accuracy of observations, by radioactive logging, of filtration and diffusion processes in clays. The only reason for waste vertical migration was deterioration of the technical state of the injection wells - isolation of the annulus and leaks in the casings. Dispersion of the injected waste front is shown by formation of a mixed zone within the strata zone, but significant extension of the waste dispersion area has not been observed.

There is dependence of the dispersion coefficient on waste movement velocity, with slowing down as waste moves from the injection well and delay processes develop in the distribution of waste components. In the formation of the transitional zone, density is changing monotonously between wastes and strata waters, reducing the gravitation effect on waste distribution. Bedding of the reservoir horizon is an additional factor reducing the gravitation effect.

Following are results of the observations: gamma logging (Fig.1) shows that gravitation differentiation occurs only within the limits of the layer (for example 390.5 - 394.0 m) and is represented by an increase in indices at the bottom of the layer. As a whole, similar phenomena in the bed not are observed. To investigate the location of retention rock properties, we have used the passage of the waste front through the observation well. Radioactivity logging, which defines the gamma-emitting nuclides content in the rocks,



and temperature data resulting from energy release of radioactive decay, indicate the concentration of nuclides in the rocks. Delay of radioactive nuclide migration by the rocks depends on several factors, which include the salt concentrations of the wastes and strata waters, structure of pore space and rock composition, nuclides content and their form, and the acidity of the waste. Observations of the movement of the waste front through the section of the observation wells allow us to draw some conclusions:

On injection of wastes with low salt content into the sand-clay reservoir horizons containing fresh waters, radioactive nuclides are transferred to the solid phase by sorption on the rocks. The observations at the LLW site of the Siberian Chemical Complex show that the radius of nuclides dispersal from the injection well is 5-10 times lower than the radius of nonradioactive tracers contained in the waste, indicating a nuclides migration delay of factors of tens to hundreds. On injection of the wastes of high salt content, there is less delay of nuclides in the zone where rock is saturated with wastes. This zone has dispersal coefficients of some units. Along with this, the delay increases as the salt content decreases, resulting in diminution of the nuclides dispersion zone.

The least delay is observed in reservoir horizons, containing salt waters, which are characterized by predominance of secondary porosity, as observed in the limestone horizon of the deep repository in Dimitrovgrad. With increasing acidity of wastes, the retention of nuclides decreases. So in injecting wastes with high salt content and pH 1 - 2, the dispersion coefficient of Sr-90 is 0.51. The results of investigation of retention properties of the rocks differ from the laboratory data. Values of dispersion coefficients are found to be less and the nature of interaction non-balanced and much more complicated in comparison with the laboratory data. This can be explained by the presence of nuclides in different forms in wastes, and their effect on the nature of their interaction with rocks. Parameters, including the distribution coefficient, double porosity effect, and the necessary nature of nuclides retention are insufficiently investigated in the laboratory. The delay of nuclides migration is essential in the assessment of the consequences of waste injection.

While discussing the results of nuclides migration in the regions of deep well injection of liquid wastes in Russia, a question is often raised concerning the compliance of these results to earlier predictions. Considering the change of the piezometric surface of ground waters, there is practically full compliance within the limits of prediction accuracy for sandy-clay reservoir horizons in Tomsk and Krasnojarsk, and worse compliance for fractured beds, containing salt waters in Dimitrovgrad. This may be explained by the significant difference between the density of strata water with a salt content up to 250 g/l and the density of wastes.

Migration of nuclides and chemical contaminants in the reservoir-horizon is less than predicted for the sandy-clay reservoir. This may be explained by the increasing role of acting porosity as the reservoir-horizon is filled, and delay of migration resulting from geological interactions. Migration is hard to predict for the fractured reservoirs, so the predictions must to be done with a reliability factor. Therefore, in fractured rock, the localization of injected wastes within the boundaries of the subsurface exclusion zone is less assured.

Vertical filtration and diffusion in overlying confining beds is not revealed by observations within the limits of accuracy of applied methods. Vertical migration can be explained by well transfer of wastes due to deterioration of the cement seal in the well's annulus. Heating up of the geological medium resulting from energy release connected with radioactive decay is observed in injecting HL Wastes. Prediction calculations have been confirmed with great accuracy. The results of solving the inverse problem permit assessment of the concentration of the energy releasing nuclides in rocks from the wastes with high acidity. The value of the distribution coefficient is of 0.5-1.0.

Study of deep repositories for liquid radioactive wastes is to be continued. Drilling control wells in the areas of waste distribution, their investigation and examination of core samples is one of the directions of the work. Investigation of the stability of nuclides retention by rocks is a primary task, as well as nuclides forms and compounds resulting from interaction of wastes during a long period of time. Another important area is vertical migration of waste in clays overlying the reservoir horizon resulting from diffusion and









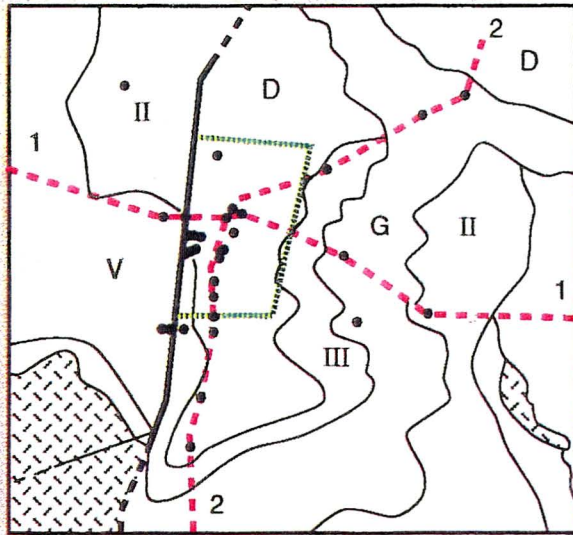

filtration. It is proposed to first drill and investigate wells in the zones of dispersion of LLW, and then MLW and HLW.

**References.**

1. Glubinnoe zahoronenie gidkih radioaktivnih othodov. IZDAT, Moscow. 1994 (in Russian)
2. Rybalchenko, A. I., M. K. Pimenov and V. M. Kurochkin. Scientific and Practical Results of Deep-Injection Disposal of Liquid Radioactive Wastes in Russia. In: *Deep Injection Disposal of Hazardous and Industrial Wastes*. Academic Press, 1996.

**Injection polygon at Krasnoyarsk-26 showing the bounding tectonic fault and a cross-section of the layered injection scheme for low, intermediate and high-level liquid wastes**



-  Permeable Strata
-  "Poorly" Permeable Strata
-  Basement Rocks
-  Alluvial Deposits
-  Radioactive Waste Disposal Zone
-  Tectonic Fault
-  Geological Cross-Section Line and Exploratory Wells (plan)
-  Exploratory Wells
-  "Polygon" Boundary
-  Stratigraphic Index

**Cross Section 1-1**

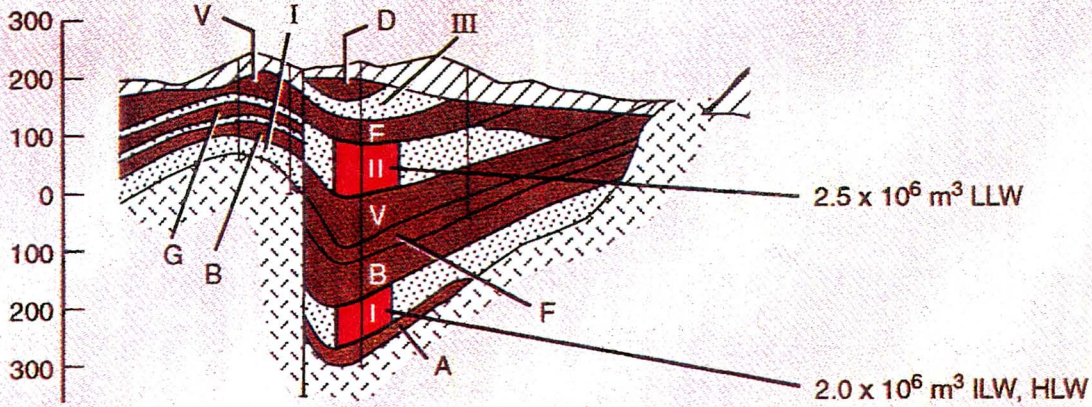

**Cross Section 2-2**

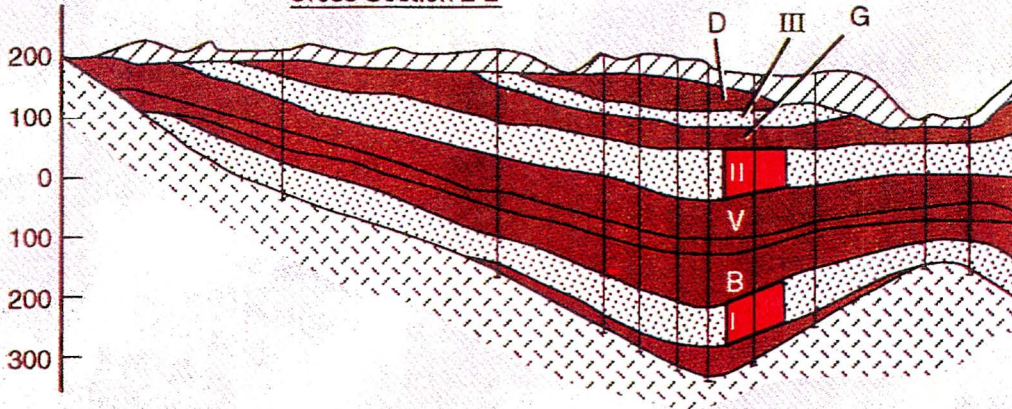

SG95100288.3C

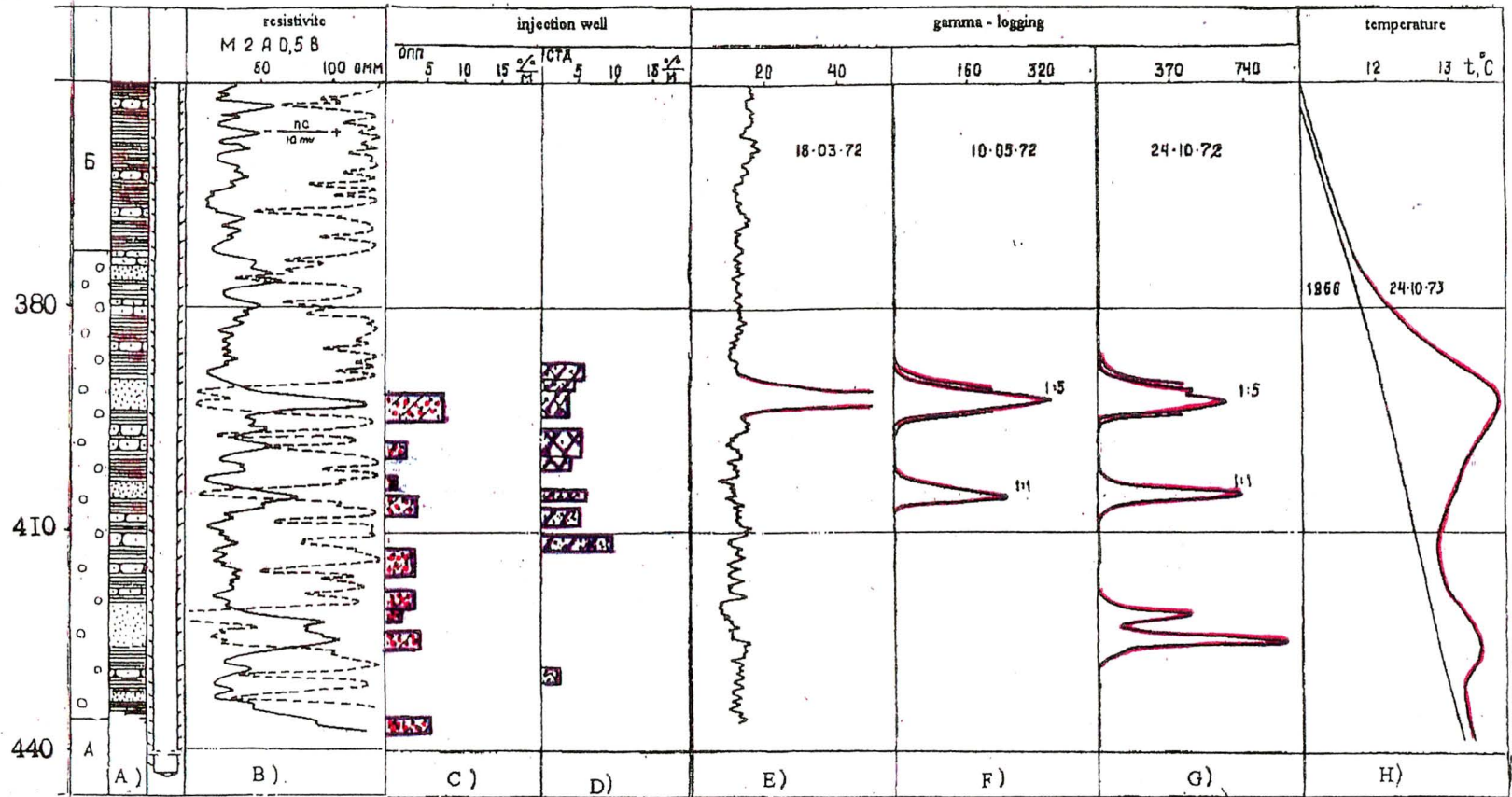

Fig. 1. Geophysical investigation of well A-4.

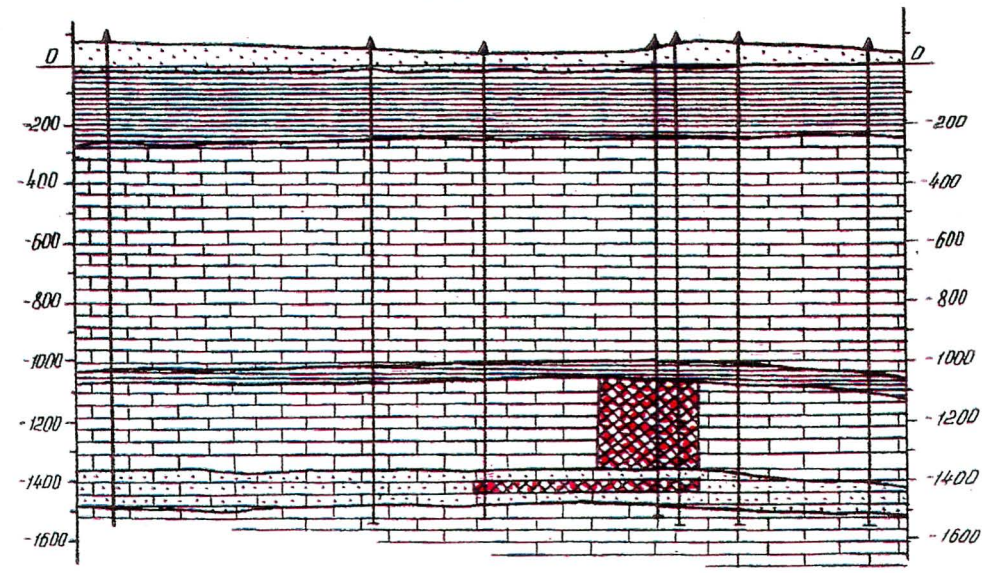
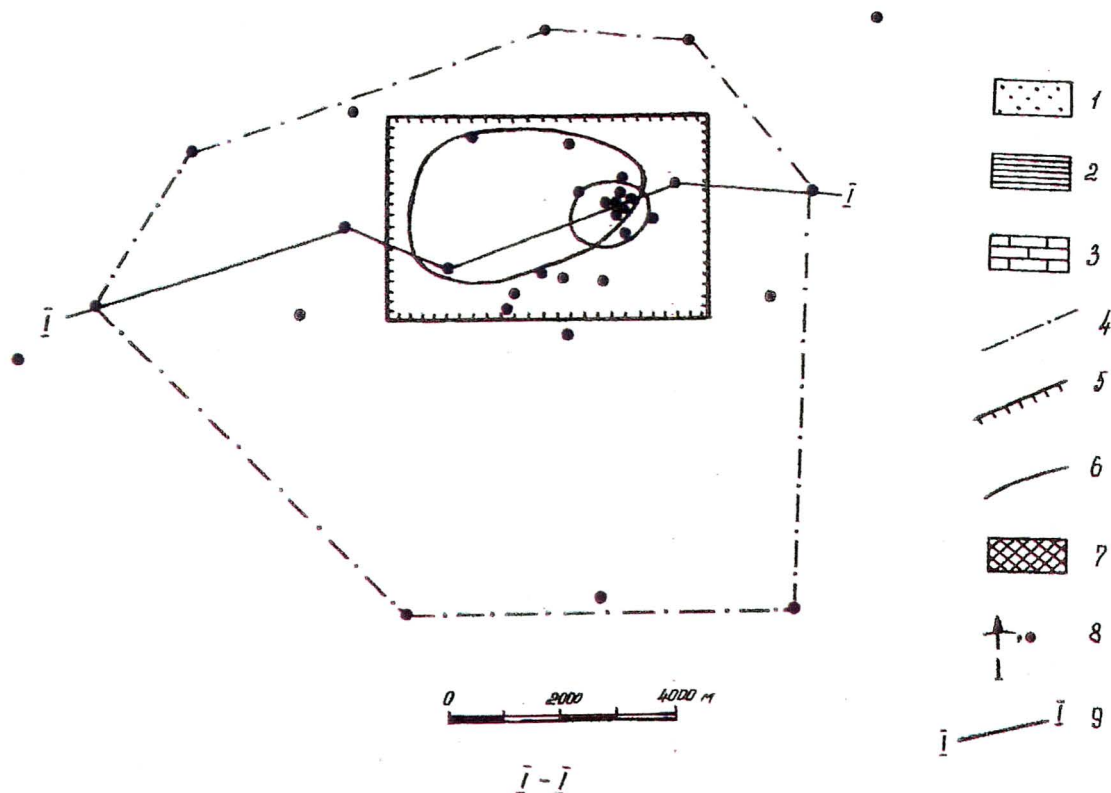

Fig. 3 . Deep-well injection facility, Dymytrovogred  
 1, 3 - permeable rocks; 2 - impermeable rocks, 4 - allotment boundary; 5 - boundary of facility; 6 - outline of waste; 7 - waste in horizon collector; 8 - well; 9 - section line

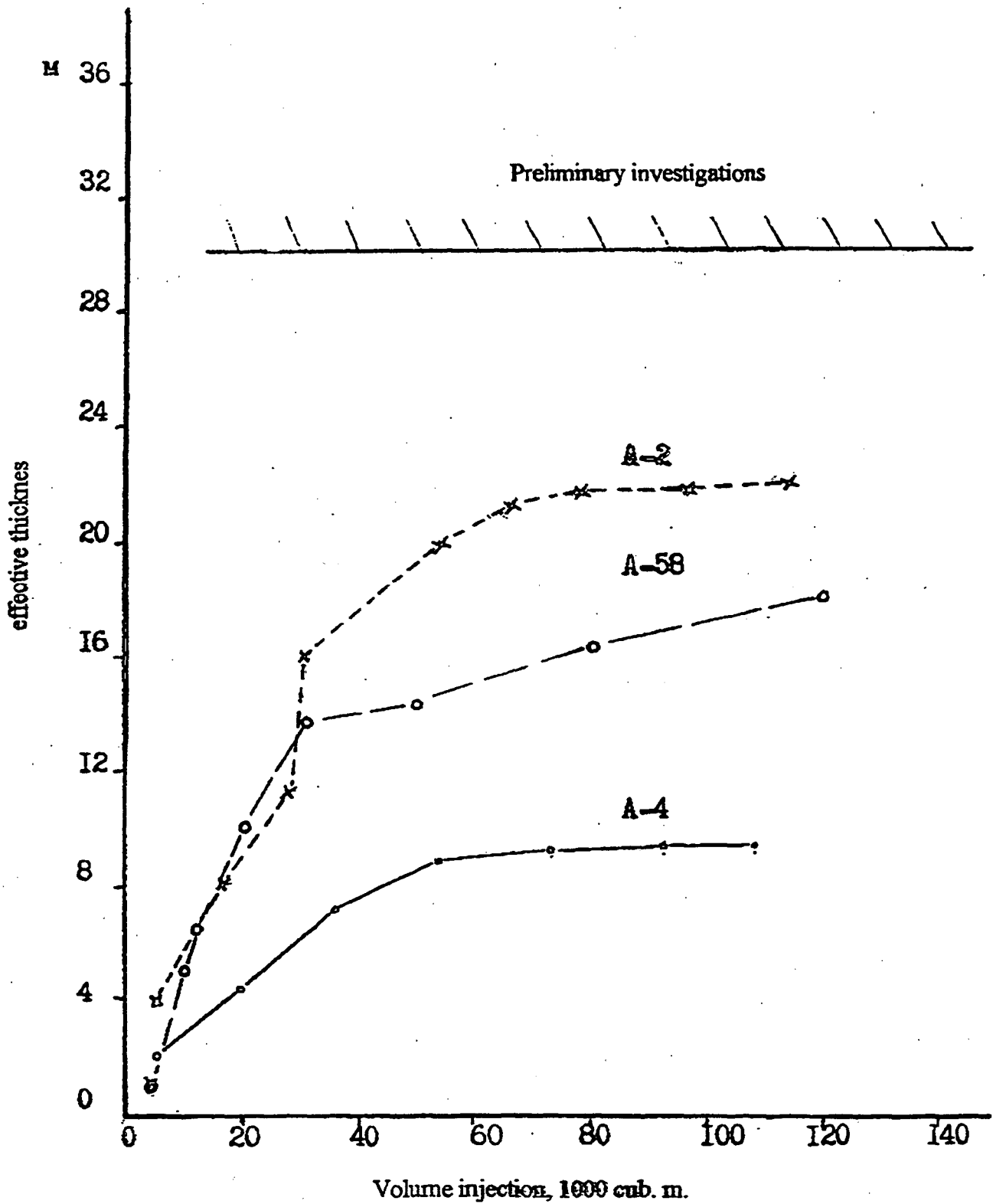

Fig. 2. Dependence of effective thickness of volumes of injection wastes.

Table 1.

DISTRIBUTION OF LIQUID RADIOAKTIVE WASTE  
IN COLLECTOR-HORIZONS /1/

	Situation of facility	Depth of collector-horizon, m	Type of rock of collector	Volume of injection, million cub. m	Area of distribution of radwaste <i>sq. km</i>	
					Prediction	Observation
1	Krasnojarsk	180-280	shaly sand	2.8	3.3	1.7
		355-500		2.2	1.8	1.2
2	Tomsk	270-320	shaly sand	32	8.3	3.5
		349-386		1.9	3.6	1.7
		314-341				
3	Dimitrovgrad	1130-1410	limestone	1.6	3.0	1.5
		1440-1550	sandstone limestone	0.6	1.5	6.0



**Preliminary Assessment of Radionuclide  
Migration from HLW Deep-Borehole Repository:  
PA “Mayak” Site, South Urals, Russia**

**Malkovsky V.I. and Pek A.A.**  
Institute of Geology of Ore Deposits  
Petrography, Mineralogy and Geochemistry  
Russian Academy of Sciences  
Moscow, Russia

July 8 - 9, 1997

**JOINT RUSSIAN-AMERICAN HYDROGEOLOGY SEMINAR**

Russian - American Center for Contaminants Transport Studies  
Ernest Orlando Lawrence Berkeley National Laboratory  
Berkeley, California 94720

---

PRELIMINARY ASSESSMENT OF RADIONUCLIDE MIGRATION FROM HLW  
DEEP-BOREHOLE REPOSITORY: PA "MAYAK" SITE, SOUTH URALS, RUSSIA

V.I.Malkovsky, A.A.Pek

Institute of Geology of Ore Deposits,  
Petrography, Mineralogy and Geochemistry,  
Russian Academy of Sciences,  
Moscow, Russia

---

ABSTRACT

This paper presents preliminary results of numerical modeling of radionuclides transport by groundwater from the high-level nuclear waste (HLW) repository at the PA "Mayak" site, Southern Urals, Russia. Vitrified HLW are supposed to be disposed in the deep-borehole repository. Transport of radionuclides from the repository by regional groundwater flow and by thermal convection flow was simulated. The regional groundwater flow simulation was carried out for the two-dimensional vertical section model. Previously obtained results on transport of radionuclides by thermal convection flow from the single-borehole and two-borehole repository models are briefly summed up. Based on the analysis of the previously obtained results, the problem of reliability of numerical simulation results is considered. It is suggested that in the cases with a wide range of radionuclide concentration variations a modified formulation of mass transfer equation should be used. The results of thermal convection transport of radionuclides from a single-borehole repository obtained with use of a modified formulation of the mass transfer equation are presented.

The overall conclusion on the potential consequences of HLW disposal at the PA "Mayak" site is that the site deserves further investigation with the main objective of assessment of the potential influence on radionuclide escape of the fracture controlled migration.

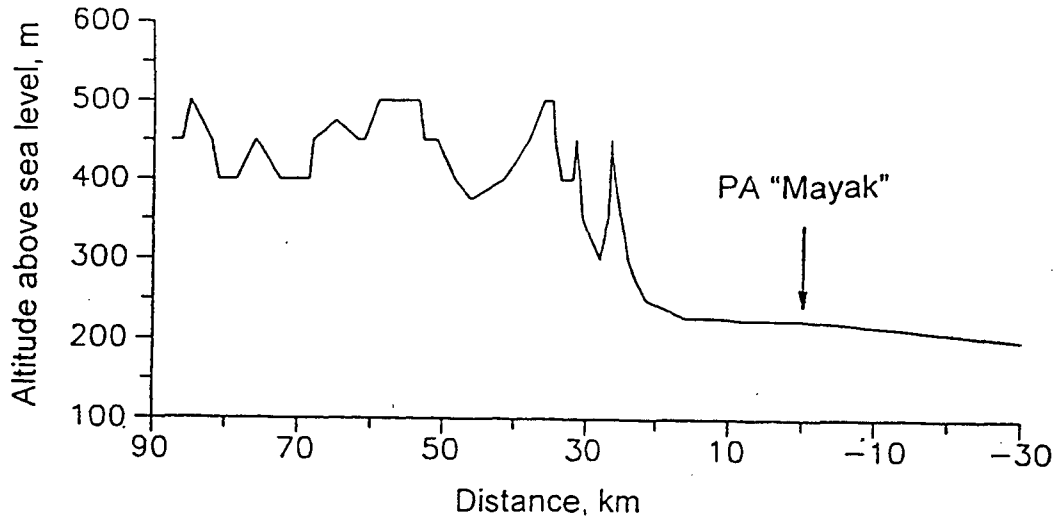

Fig. 1. Topography along the west-east profile extending through the PA "Mayak" territory. Distance is indicated from the PA "Mayak" site (zero point).

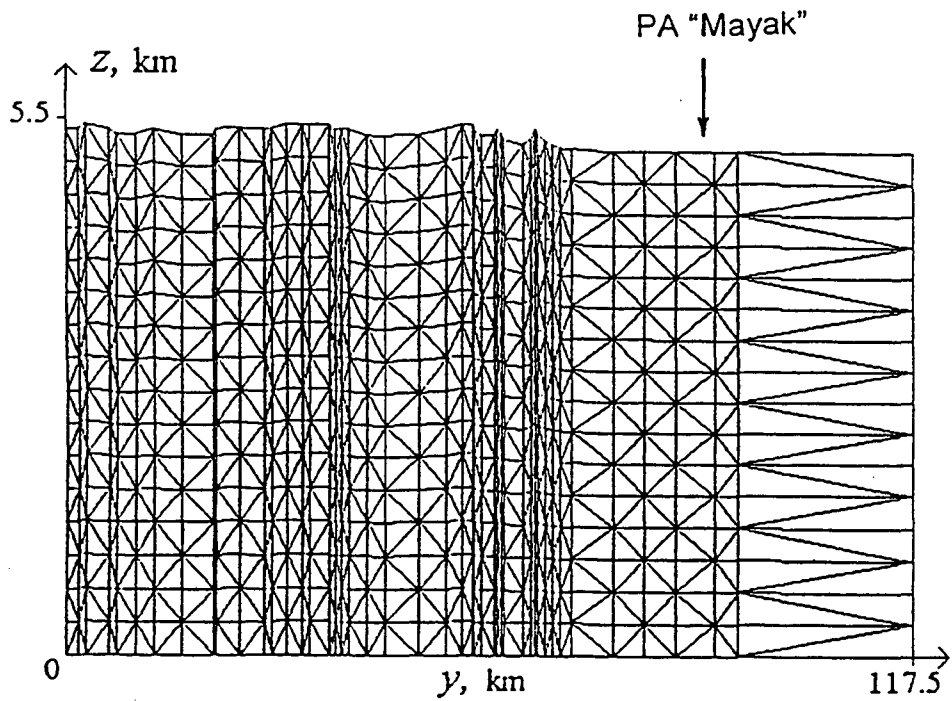

Fig. 2. Finite element mesh.

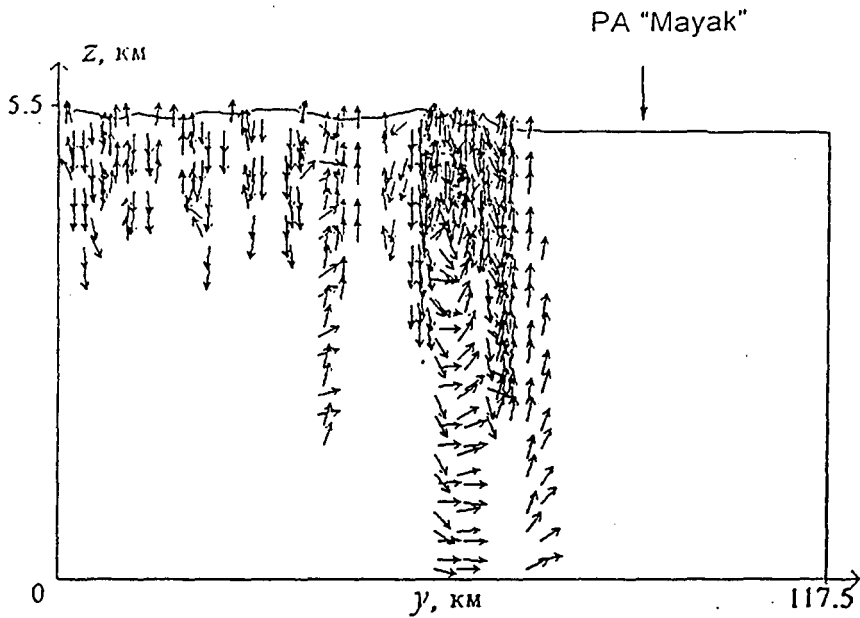

Fig. 3. Regional groundwater flow.

Orientation of flow velocity vectors accounts for difference in scale along z and y axes.

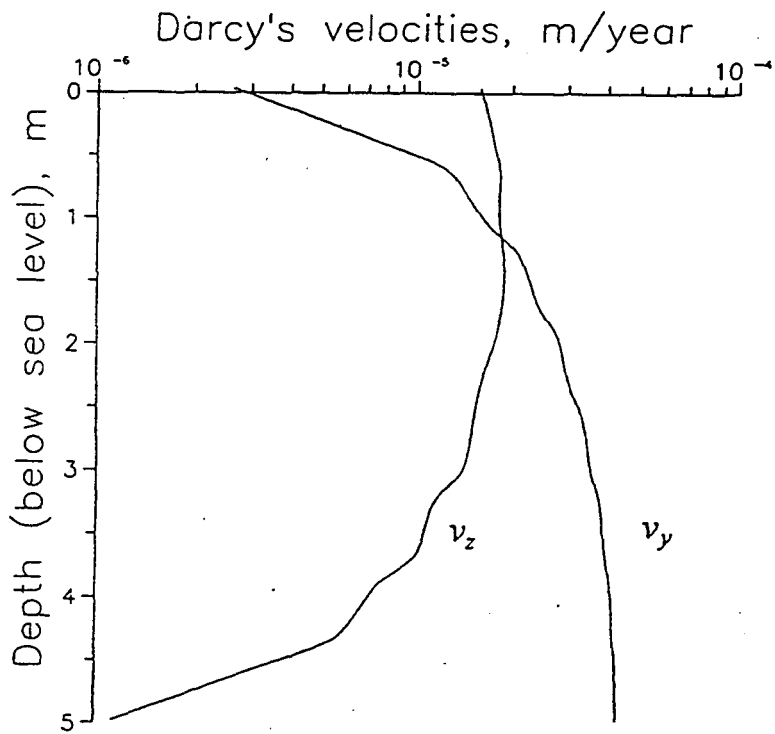

Fig. 4. Vertical  $v_z$  and horizontal  $v_y$  regional flow velocity values versus depth at the PA "Mayak" site.

Permeability  $k = 10^{-15} \text{ m}^2$ .

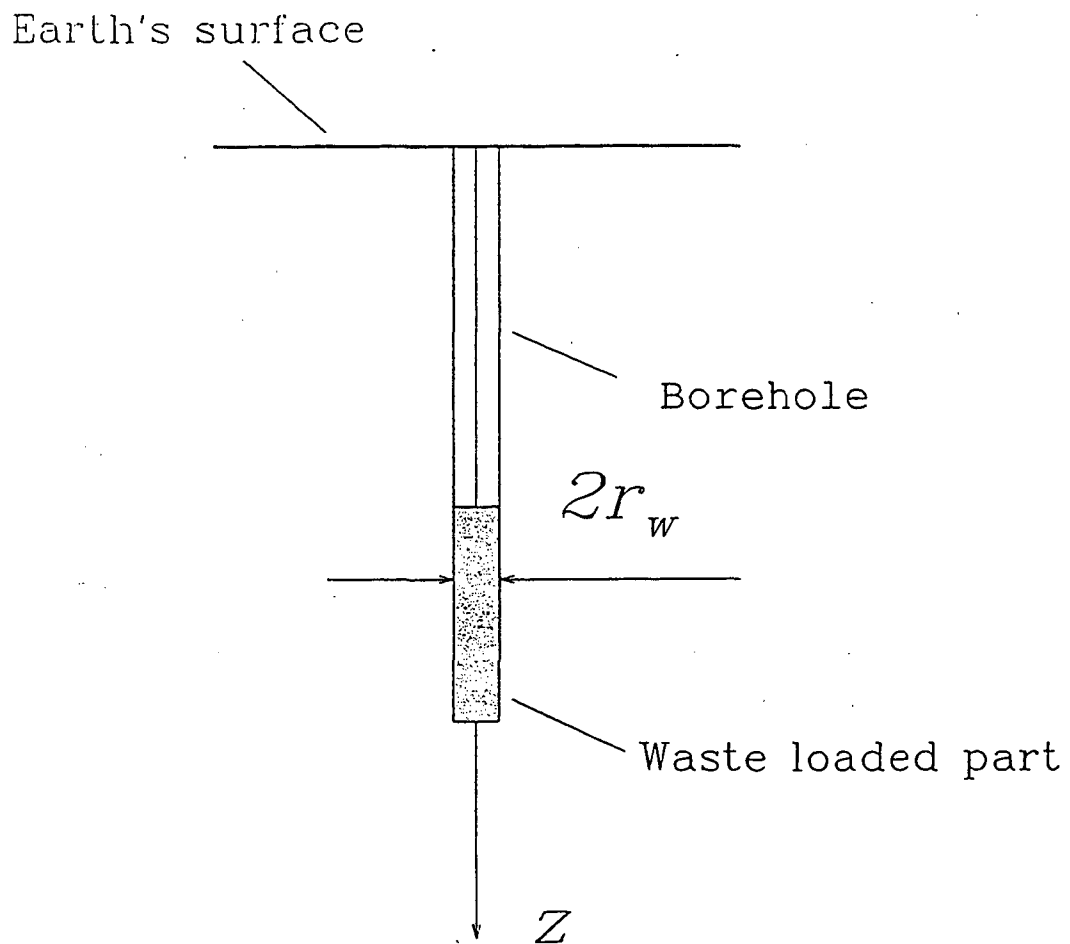
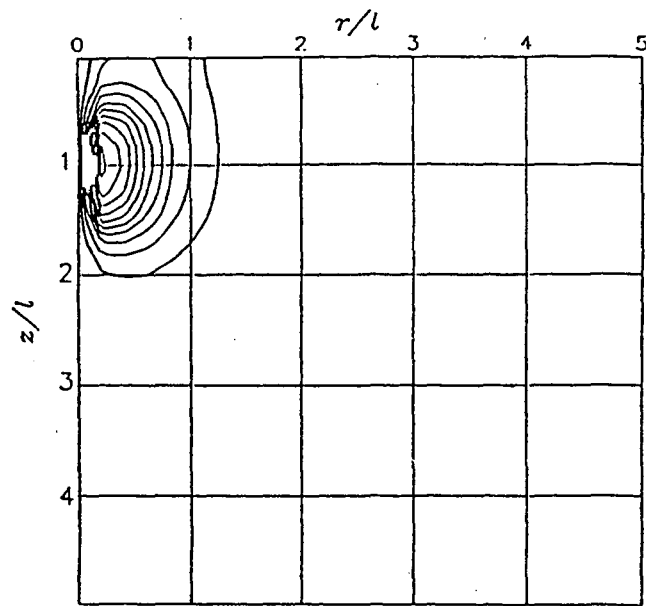
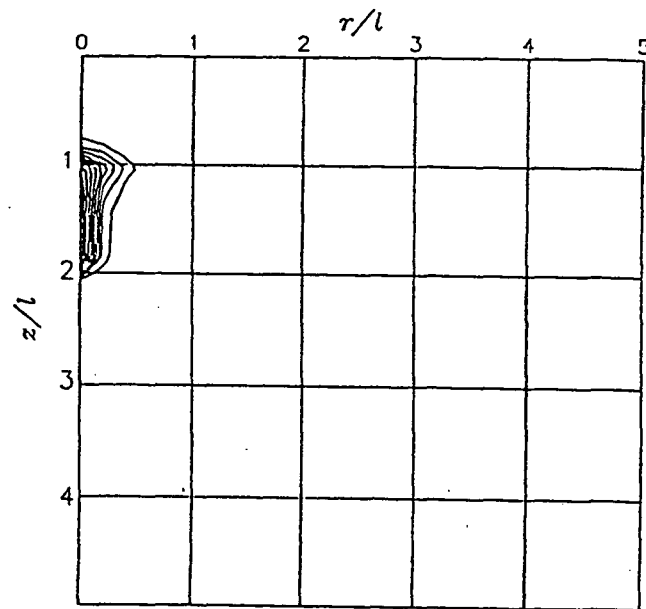

Fig. 5. Single-borehole model



a



b

Fig. 6. Streamlines (a) and concentration field (b).

a - flow function  $\psi$  levels are shown with a step of  $0.1 \cdot \psi_{\max}$ ;  
 $z_1/l = 0.5$ ;  $z_2/l = 1.5$ .

b - concentration levels are shown with a step of  $0.2 \cdot C_{\max}$ ;  
 $z_1/l = 1.0$ ;  $z_2/l = 2.0$ .

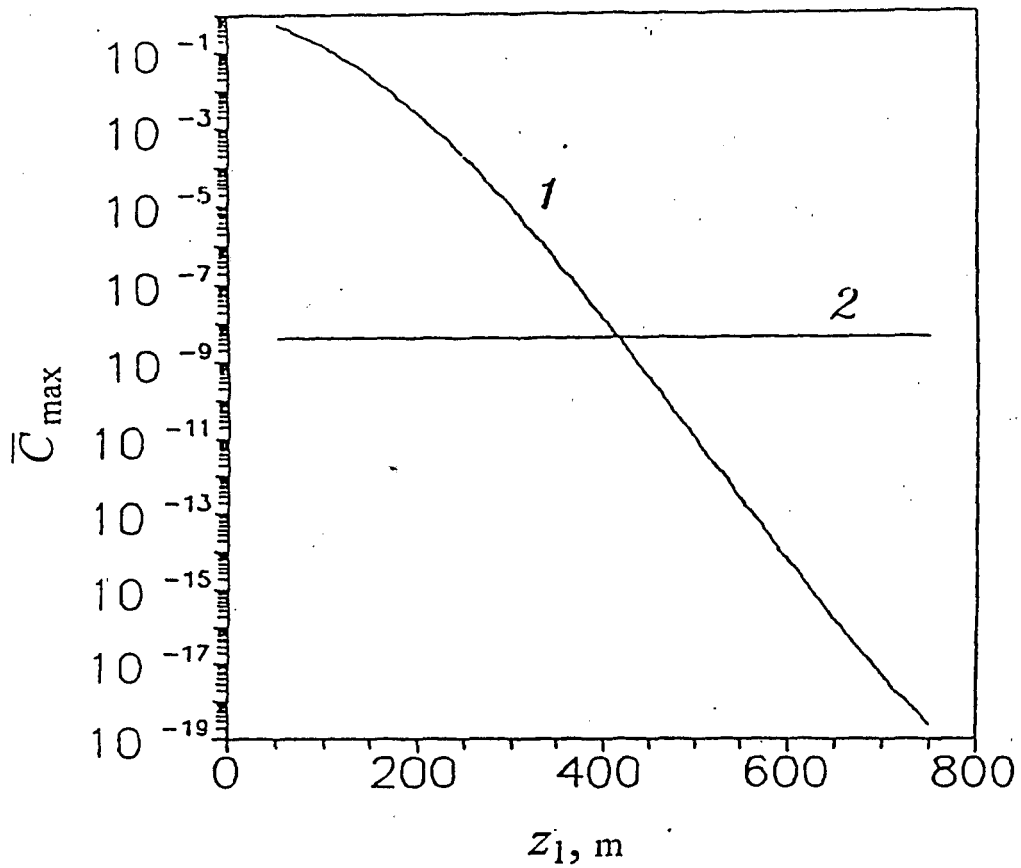
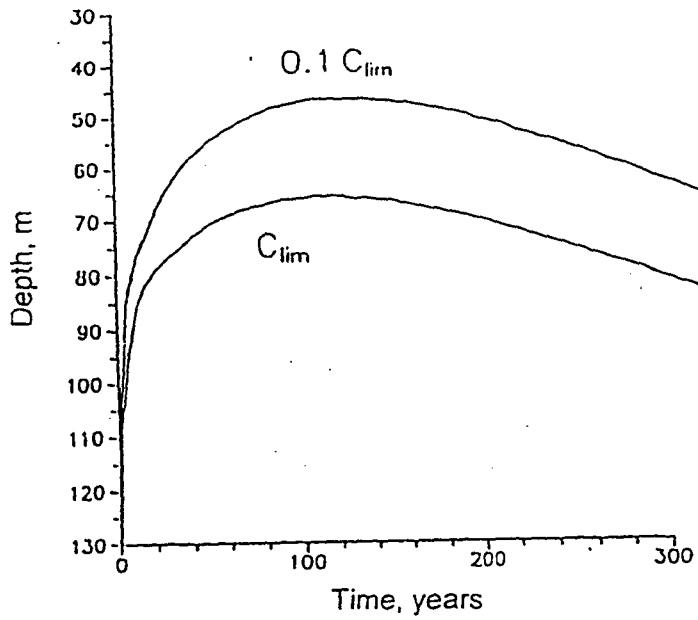
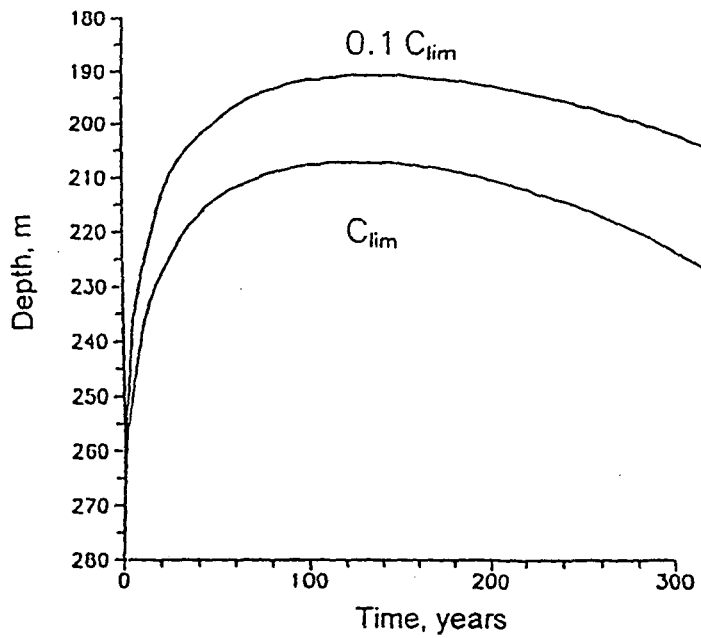

Fig. 7. Dependence of the maximum normalized concentration  $\bar{C}_{\max}$  of  $^{90}\text{Sr}$  in groundwater at the Earth's surface on the depth  $z_1$  of HLW disposal.

1 -  $\bar{C}_{\max}$ ; 2 - normalized Maximum Permissible Concentration.



a



b

Fig. 8. Dynamics of propagation along the repository axis of symmetry of  $^{90}\text{Sr}$  contamination front.

a.  $z_1 = 150$  m,  $z_2 = 750$  m.

b.  $z_1 = 300$  m,  $z_2 = 900$  m.



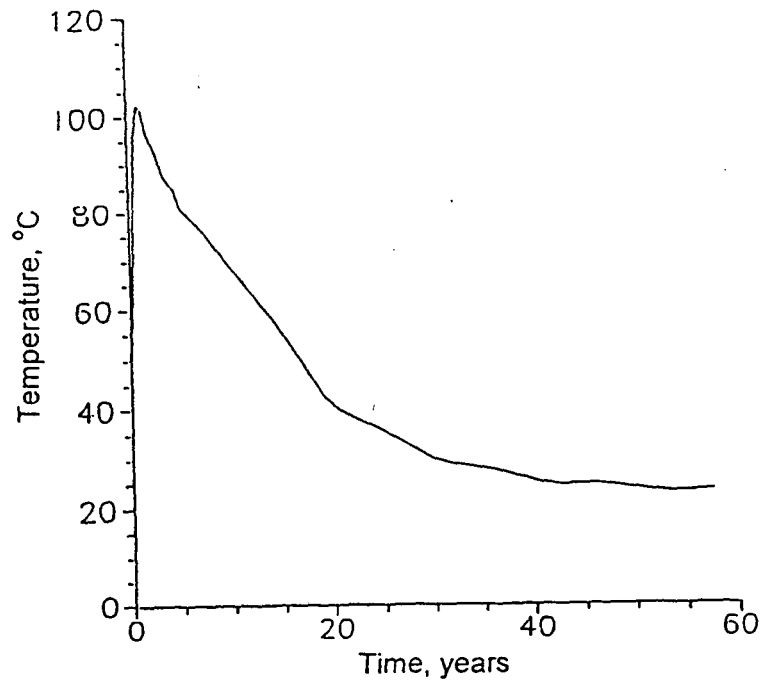

Fig. 9. Dependence on time of the maximum temperature in the repository near field.

$$z_1 = 150 \text{ m}, z_2 = 750 \text{ m}, T_0 = 293 \text{ K}.$$

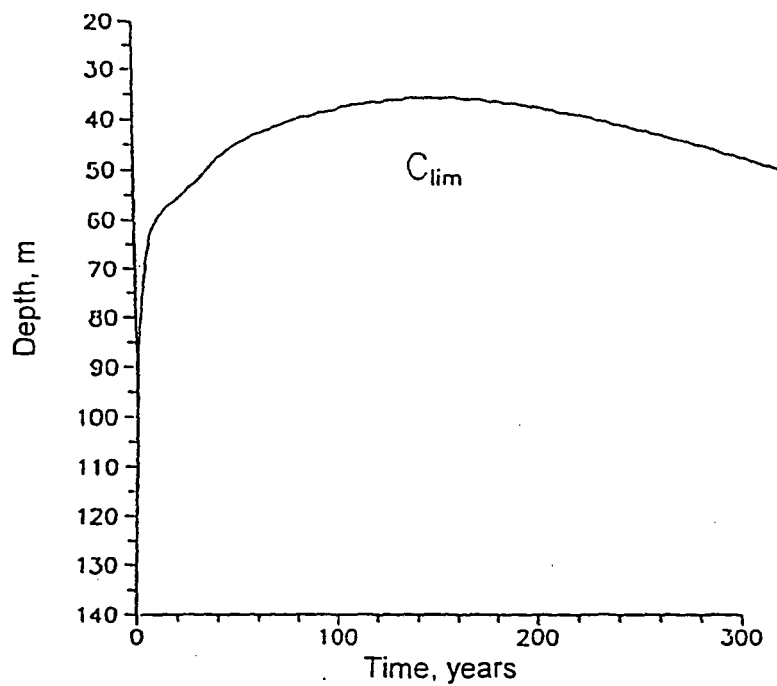

Fig. 10. Dynamics of propagation along the repository axis of symmetry of  $^{90}\text{Sr}$  contamination front with concentration  $C = C_{\text{lim}}$ .

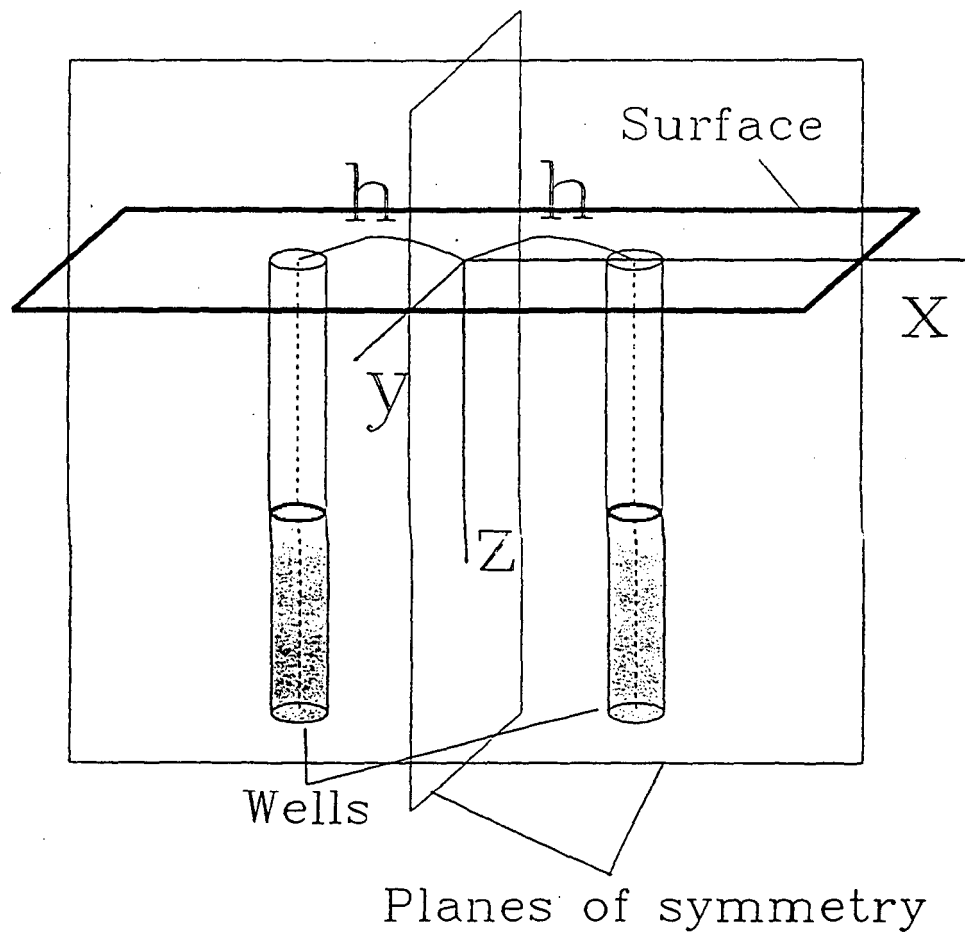

Fig. 11. Scheme of the two-borehole repository.

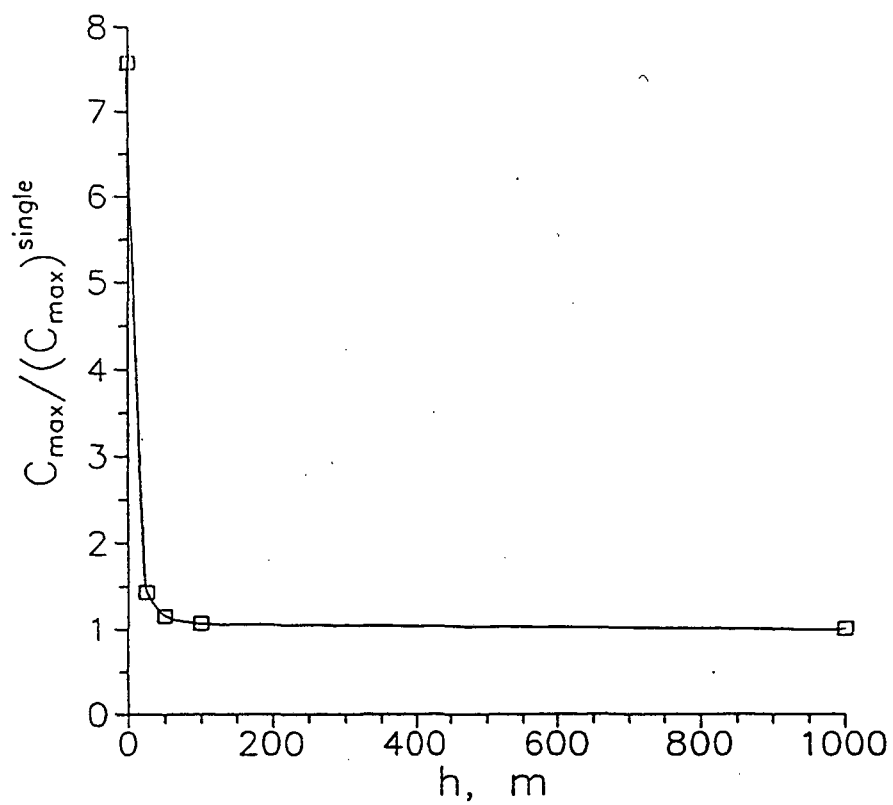

Fig. 12. Dependence of the maximum normalised <sup>90</sup>Sr concentration in the groundwater at the Earth's surface on the distance between the disposal boreholes.

# **Migration of liquid plume in sloping aquifer**

**Malkovsky V. I. and Pek A. A.**  
IGEM, Russian Academy of Sciences

**Chin-Fu Tsang**

E.O. Lawrence Berkeley National Laboratory

July 8 - 9, 1997

## **JOINT RUSSIAN-AMERICAN HYDROGEOLOGY SEMINAR**

Russian - American Center for Contaminants Transport Studies  
Ernest Orlando Lawrence Berkeley National Laboratory  
Berkeley, California 94720

During the first years of development of atomic industry, the risk associated with radioactive wastes was underestimated. In 1949-1951 at the first radiochemical enterprise in Russia, liquid radioactive waste (LRW) were discharged into the river. In 1951 this dumping into the river was stopped. High level radioactive wastes were temporarily stored in specially designed tanks. Low and intermediate level radioactive wastes came to be accumulated open reservoirs. Temporary storage option is inadequate for low and intermediate level wastes because of their huge volume. Partial solution of the problem lays with the development and implementation of underground disposal technique through injection of LRW into deep aquifers confined from top and bottom by low permeable rocks.

Interaction between injected waste, host rocks, and formation water is of considerable importance in process of radionuclides migration. Safety of LRW injection disposal can be enhanced by sorption of radionuclides by mineral matrix of host rocks. High sorption capacity for radionuclides exhibit clay and sandy-clayey deposits what brings forward an extra argument in favor of waste disposal in sedimentary basins. One more factor of safety enhancement is caused by reactions of precipitation and co-precipitation. From consideration of uranium deposits which have much in common with LRW disposal system, and taking into account intensity of these reactions, LRW injection into the aquifer with reducing conditions can be recommended for enhancement of long-term safety of LRW disposal system.

But conceivably long-term safety of LRW disposal system depends even to a greater extent on distribution of ground water flow velocity in the aquifer because this distribution can be the governing factor in convective transport of radionuclides by groundwater. Aquifer destined for waste injection is not strictly horizontal. That is why if salinity of formation water is lower than solute mass concentration of injected waste (represented, as a rule, by aqueous solutions) contamination plume sinks down the dip of the aquifer. If heat generation caused by radioactive decay processes is essential, warming up of injected solutions causes decrease in their density, and, as a result, components of buoyancy force

can vary in magnitude and even reverse direction, and, as a result, contamination plume can move up-dip the aquifer.

Movement of injected solutions is governed by both driving mechanisms: buoyancy forces (caused by difference between densities of formation water and injected waste) and regional flow of ground water in the aquifer. Joint action of these factors can accelerate or, conversely, decelerate movement of contamination plume in the aquifer. From the viewpoint of disposal safety, conditions should be chosen whereby these driving forces suppress each other, and displacement of contamination plume from the injection site is minimal. For study of mixed convection process and its influence on the plume behavior, 2-D areal model was considered in Boussinesq's approximation. It was assumed that flow velocity satisfies Darcy's law, and contamination transport can be described by the equation of transient convective mass transfer. Precipitation reactions and sorption were not taken into account what permits to consider estimations obtained as conservative approach. Analytical solution was obtained which describes plume movement at the initial stage of the process. General case was described by results of computer simulation.

# **Migration of liquid radioactive plume in sloping aquifer**



- 1. STATEMENT OF THE PROBLEM**
  
- 2 ANALYSIS OF PROCESSES GOVERNING  
RADIONUCLIDE MIGRATION IN THE AQUIFER**
  
- 3 MATHEMATICAL MODEL.  
PROBLEM FORMULATION**
  
- 4 DESCUSSION OF RESULTS**
  
- 5 CONCLUSION**

- Underestimation of the risk associated with radioactive waste within the first years of development of atomic industry.
- Since 1951 dumping of liquid radioactive waste into river system was stopped. High level radioactive wastes were temporarily stored in tanks. Low to intermediate level radioactive wastes came to be accumulated in the open reservoirs.
- Refined technology of temporary storage in tanks can solve the problem of HLW storage for the present. However, the temporary storage option was inadequate for localization of the low to intermediate level LRW because of their huge volume
- For the period of more than 30 years,  $50 \cdot 10^6 \text{ m}^3$  of LRW with the total radioactivity of  $\sim 2 \cdot 10^9 \text{ Ci}$  were disposed in Russia [Laverov, et al, 1994; Rybalchenko et al 1994] with use of injection into deep aquifers confined from top and bottom by low permeable rocks



## **Analysis of processes governing radionuclides migration in the aquifer**

- Safety of LRW injection disposal can be enhanced by sorption of radionuclides by mineral matrix of the host rock
- The highest capacity for radionuclide retardation exhibit clay and sandy-clayey deposits what brings forward an extra argument in favour of LRW disposal in sedimentary basins.
- One more factor of safety enhancement is caused by reactions of precipitation and co-precipitation. Intensity of these reactions depends on oxidation-reduction conditions in the LRW injection zone. From consideration of uranium deposits which have much in common with the LRW injection systems, LRW injection into aquifer with reducing conditions can be recommended for enhancement of long-term safety of disposal system.

- But conceivably long-term safety of LRW injection disposal depends even to a greater extent on distribution of velocity of ground water flow in injection zone of the aquifer because this distribution can be the governing factor in convective transport of radionuclides by ground water.
- As a rule, wastes injected into the layer are represented by aqueous solution which density differs noticeably from the density of formation ground water at the expense of dissolved components. Heat generation caused by radioactive decay leads to heating injected solutions and, hence, to a decrease in their density. Waste are injected into the layer which is not faithfully horizontal in the general case what causes nonzero component of buoyance force driving the plume along the aquifer.

Movement of injected solutions in the aquifer is governed by both these factors: buoyancy forces (caused by difference between densities of injected solutions and formation water) and regional flow of ground water in the aquifer. Joint action of these factors can lead to acceleration or, conversely, to deceleration of contaminant migration.

## PROBLEM FORMULATION

Governing equations:

$$u_x = -\frac{k}{\mu} \left\{ \frac{\partial p}{\partial x} + \rho g \sin \alpha [1 - \beta_T (T - T_0) + \beta_C C] \right\}, \quad u_y = -\frac{k}{\mu} \frac{\partial p}{\partial y},$$

$$\frac{\partial u_x}{\partial x} + \frac{\partial u_y}{\partial y} = 0.$$

$$\frac{\partial^2 p}{\partial x^2} + \frac{\partial^2 p}{\partial y^2} = \rho g \sin \alpha \left( \beta_T \frac{\partial T}{\partial x} - \beta_C \frac{\partial C}{\partial x} \right)$$

$$\frac{\partial C}{\partial t} + \frac{1}{\varphi} \left( u_x \frac{\partial C}{\partial x} + u_y \frac{\partial C}{\partial y} \right) = D \left( \frac{\partial^2 C}{\partial x^2} + \frac{\partial^2 C}{\partial y^2} \right),$$

$$\frac{\partial K}{\partial t} + \frac{1}{\varphi} \left( u_x \frac{\partial K}{\partial x} + u_y \frac{\partial K}{\partial y} \right) = D \left( \frac{\partial^2 K}{\partial x^2} + \frac{\partial^2 K}{\partial y^2} \right) - \kappa K$$

$$\frac{\partial T}{\partial t} = a_r \frac{\partial^2 T}{\partial z^2}$$

Boundary conditions:

$$|x|, |y| \rightarrow \infty, \quad p - p_0 + \frac{v_x \mu x}{k} + \frac{v_y \mu y}{k} + \rho g x \sin \alpha, K, C \rightarrow 0$$

$$z = \pm \frac{h}{2}, \quad \lambda_r \frac{\partial T}{\partial z} = \mp \varphi K \rho \frac{h}{2} \omega + \frac{h \lambda_r}{2 a_r} \frac{\partial T}{\partial t};$$

$$|z| \rightarrow \infty, \quad \frac{\partial T}{\partial z} \rightarrow 0.$$

Initial conditions:

$$t = 0, \quad T = T_0, \quad \begin{array}{l} \sqrt{x^2 + y^2} \leq r_{00}, \quad C = C_0, K = \gamma C_0; \\ \sqrt{x^2 + y^2} > r_{00}, \quad C = K = 0. \end{array}$$

## Dimensionless form

Dimensionless variables

$$X = \frac{x}{L}, \quad Y = \frac{y}{L}, \quad Z = \frac{z-h/2}{L}, \quad \tau = \frac{t}{t_m}, \quad \xi = \frac{C}{C_0}, \quad \eta = \frac{K}{\gamma C_0},$$

$$P = \frac{k}{u_m \mu L} \left( p - p_0 + \frac{v_x \mu x}{k} + \frac{v_y \mu y}{k} + \rho g x \sin \alpha \right), \quad \theta = \frac{T - T_0}{T_m}$$

$$u_m = \frac{k}{\mu} \rho g \beta_c C_0 \sin \alpha, \quad L = \frac{D\varphi}{u_m}, \quad t_m = D \left( \frac{\varphi}{u_m} \right)^2,$$

$$l = \sqrt{a_r t_m}, \quad T_m = \frac{\varphi l \gamma C_0 \rho h \omega}{2 \lambda_r}.$$

Governing equations

$$\frac{\partial^2 P}{\partial X^2} + \frac{\partial^2 P}{\partial Y^2} = F \frac{\partial \theta}{\partial X} - \frac{\partial \xi}{\partial X},$$

$$\frac{\partial \xi}{\partial \tau} + U_x \frac{\partial \xi}{\partial X} + U_r \frac{\partial \xi}{\partial Y} = \frac{\partial^2 \xi}{\partial X^2} + \frac{\partial^2 \xi}{\partial Y^2},$$

$$\frac{\partial \eta}{\partial \tau} + U_x \frac{\partial \eta}{\partial X} + U_r \frac{\partial \eta}{\partial Y} = \frac{\partial^2 \eta}{\partial X^2} + \frac{\partial^2 \eta}{\partial Y^2} - Dc\eta,$$

$$\frac{\partial \theta}{\partial \tau} = \frac{\partial^2 \theta}{\partial Z^2}.$$

$$U_x = V_x - \frac{\partial P}{\partial X} - \xi + F\theta, \quad U_r = V_r - \frac{\partial P}{\partial Y},$$

Boundary conditions

$$|X|, |Y| \rightarrow \infty, \quad P, \xi, \eta \rightarrow 0;$$

$$Z = 0, \quad \frac{\partial \theta}{\partial Z} = -\eta + \frac{I}{2} \frac{\partial \theta}{\partial \tau};$$

$$Z \rightarrow \infty, \quad \frac{\partial \theta}{\partial Z} \rightarrow 0.$$

Initial condition

$$\tau = 0, \quad \theta = 0, \quad \begin{cases} \sqrt{X^2 + Y^2} \leq R_m, & \xi = \eta = 1; \\ \sqrt{X^2 + Y^2} > R_m, & \xi = \eta = 0. \end{cases}$$

## Dimensionless governing parameters

$$F = \frac{T_m \beta_T}{C_0 \beta_c},$$

determines a ratio between Archimedean force components caused by nonhomogeneous distributions of temperature and concentration, respectively

$$Dc = \kappa t_m,$$

determines a ratio between time scales for processes of convective mass transfer and radioactive decay

$$V_x = \frac{v_x}{u_m}, \quad V_r = \frac{v_r}{u_m}$$

characterize a ratio between regional flow velocity and velocity of the flow caused by Archimedean forces.

$$R_{in} = \frac{r_{in}}{L},$$

an analog of Peclet number and characterizes a relative contributions of convection and dispersion to the mass transport

$$I = \frac{h}{l}.$$

characterizes the thermal inertia of the aquifer in the process of heat exchange with the confining rock beds

### Plume movement characteristics

$$X^{mass}(\tau) = \frac{\iint X \xi(X, Y, \tau) dX dY}{\iint \xi(X, Y, \tau) dX dY}, \quad Y^{mass}(\tau) = \frac{\iint Y \xi(X, Y, \tau) dX dY}{\iint \xi(X, Y, \tau) dX dY}$$

$$U_x^{mass}(\tau) = \frac{X^{mass}(\tau)}{\tau}, \quad U_r^{mass}(\tau) = \frac{Y^{mass}(\tau)}{\tau}$$

$$R_{mass}(\tau) = \frac{3 \iint \sqrt{[X - X^{mass}(\tau)]^2 + [Y - Y^{mass}(\tau)]^2} \xi(X, Y, \tau) dX dY}{2 \iint \xi(X, Y, \tau) dX dY}$$

# Low level radioactive waste

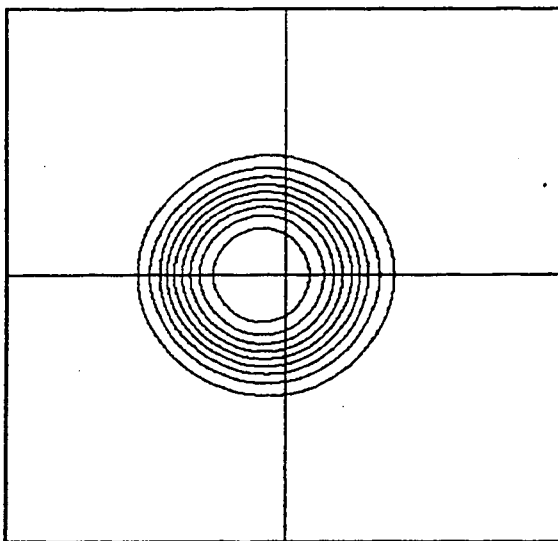

$\tau = 5$

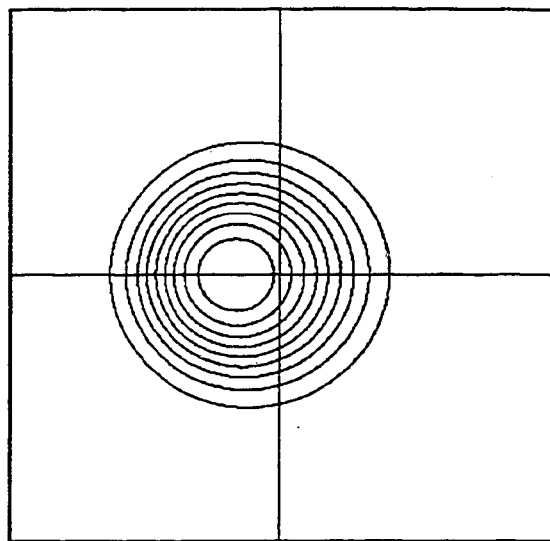

$\tau = 10$

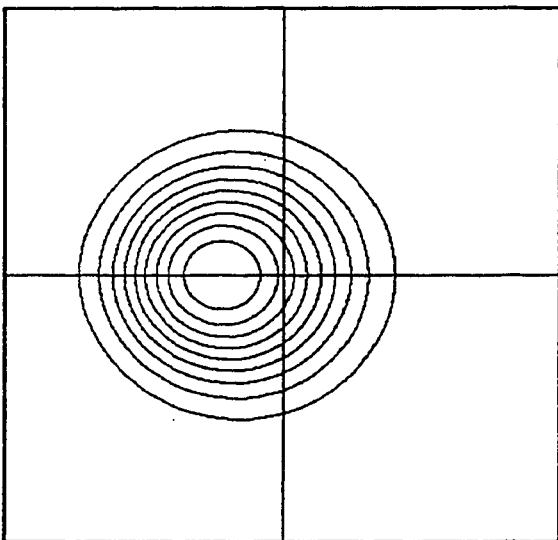

$\tau = 15$

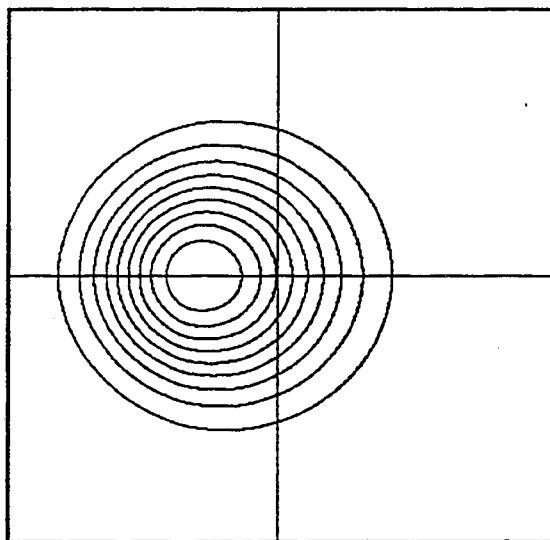

$\tau = 20$

$F=0, R_{in} = 10$

# Low level radioactive waste

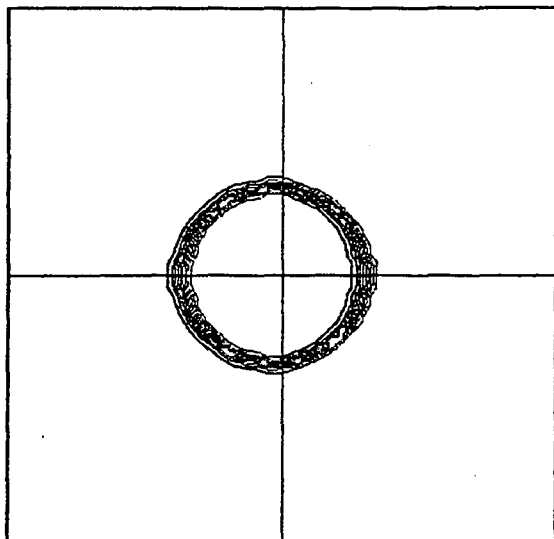

$\tau = 20$

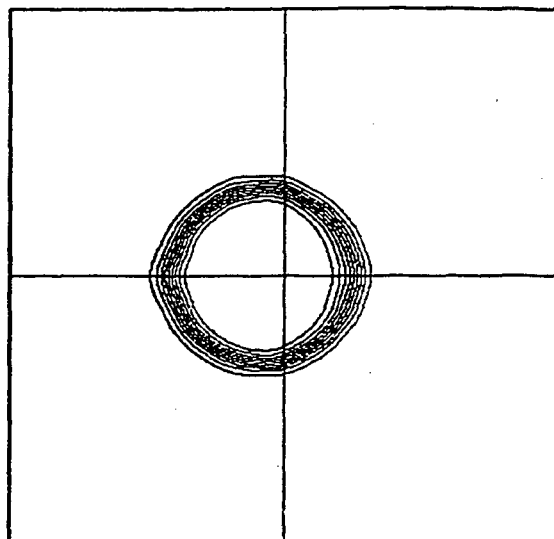

$\tau = 50$

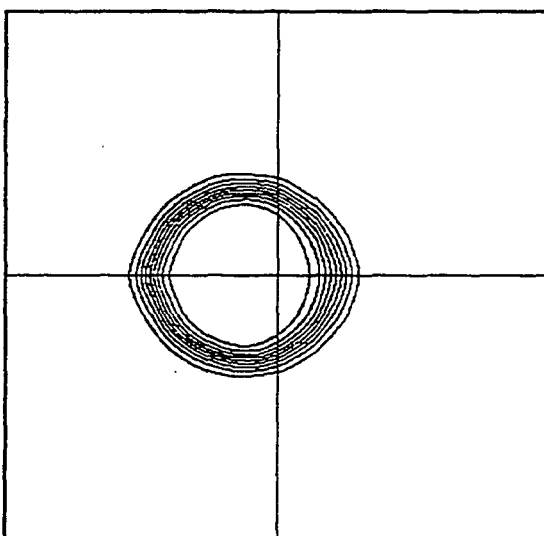

$\tau = 75$

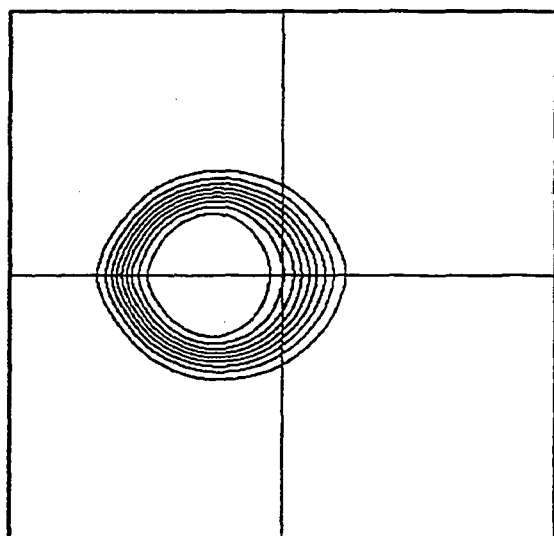

$\tau = 150$

$$F = 0, R_{in} = 100$$

### Analytical solution at small $\tau$

$$\xi = \begin{cases} 1, & R \leq R_{in}; \\ 0, & R > R_{in}, \end{cases} \Rightarrow \quad \frac{\partial \xi}{\partial \vartheta} = 0, \quad \frac{\partial \xi}{\partial R} = -\delta(R - R_{in})$$

$$\frac{1}{R} \frac{\partial}{\partial R} \left( R \frac{\partial P}{\partial R} \right) + \frac{1}{R^2} \frac{\partial^2 P}{\partial \vartheta^2} = \delta(R - R_{in}) \cos \vartheta.$$

If  $P$  is represented as  $P = P_1 \cos \vartheta$  then

$$\frac{1}{R} \frac{d}{dR} \left( R \frac{dP_1}{dR} \right) - \frac{1}{R^2} P_1 = \delta(R - R_{in}).$$

If  $\zeta = \ln(R/R_{in})$ , having regard to

$$\delta(R - R_{in}) = \delta(\zeta - \zeta(R_{in})) \frac{d\zeta}{dR},$$

$$\frac{d^2 P_1}{d\zeta^2} - P_1 = R_{in} \delta(\zeta).$$

$$P_1 = \begin{cases} s_1 e^\zeta, & \zeta < 0; \\ s_2 e^{-\zeta}, & \zeta > 0. \end{cases}$$

$$P_1(-0) = P_1(+0), \quad P_1'(+0) - P_1'(-0) = R_{in}.$$

$$s_1 = s_2 = -\frac{R_{in}}{2},$$

$$P = \begin{cases} -\frac{1}{2} R \cos \vartheta = -\frac{X}{2}, & R \leq R_{in}; \\ -\frac{1}{2} \frac{R_{in}^2}{R} \cos \vartheta, & R > R_{in}. \end{cases}$$

$$R \leq R_{in}, \quad U_x = -\frac{\partial P}{\partial X} - \xi = -\frac{1}{2}.$$

$$U_x^{max} = -\frac{1}{2}, \quad U_r^{max} = 0$$



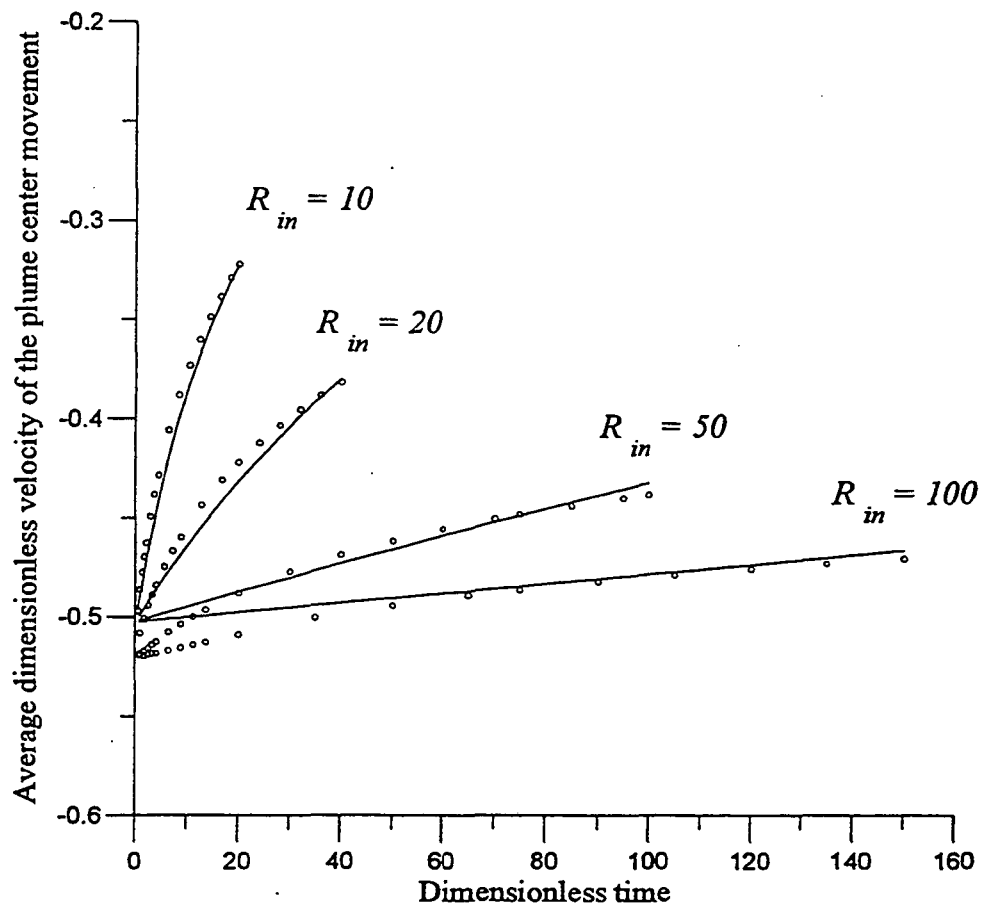

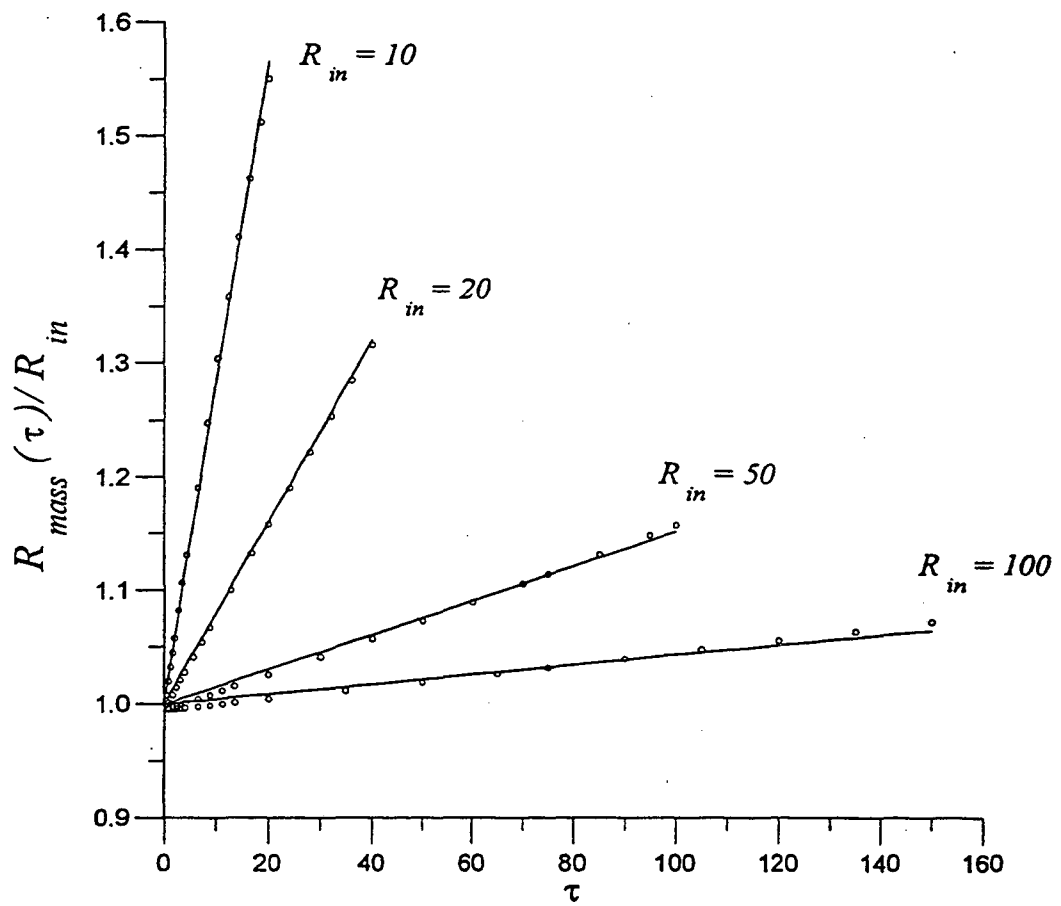

## High level radioactive waste

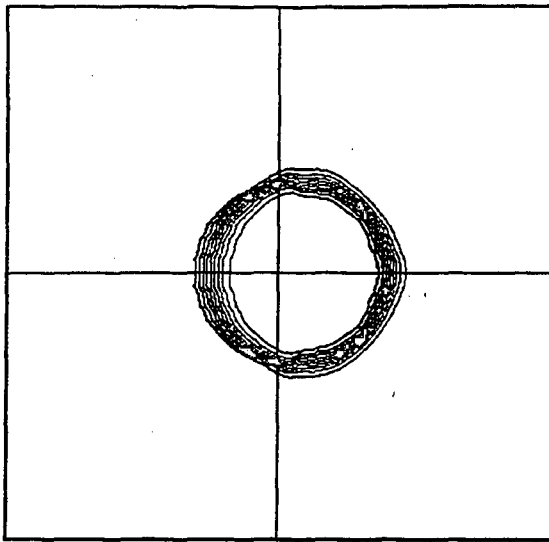

$\tau = 20$

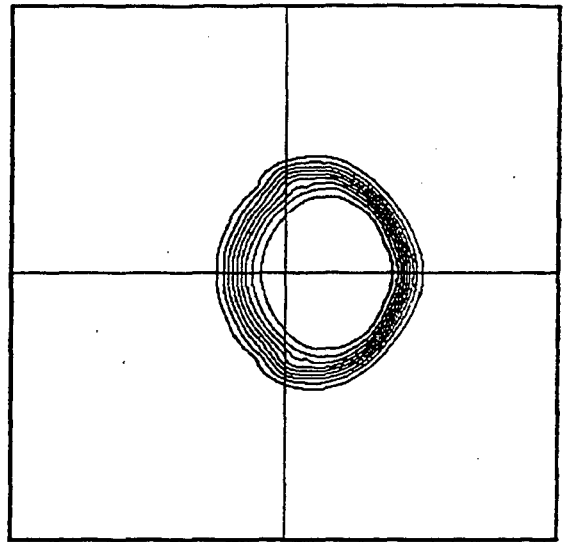

$\tau = 50$

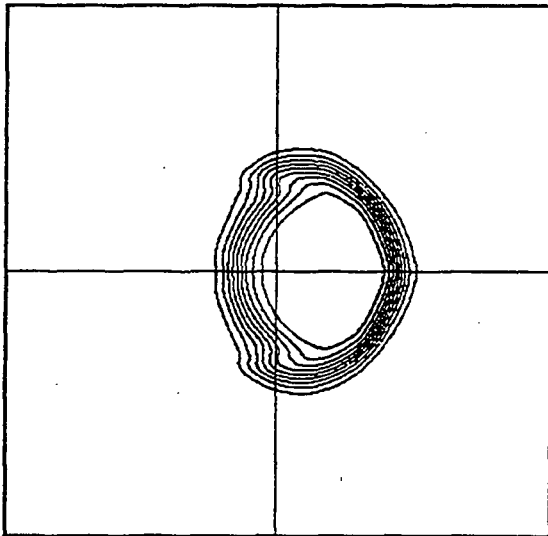

$\tau = 75$

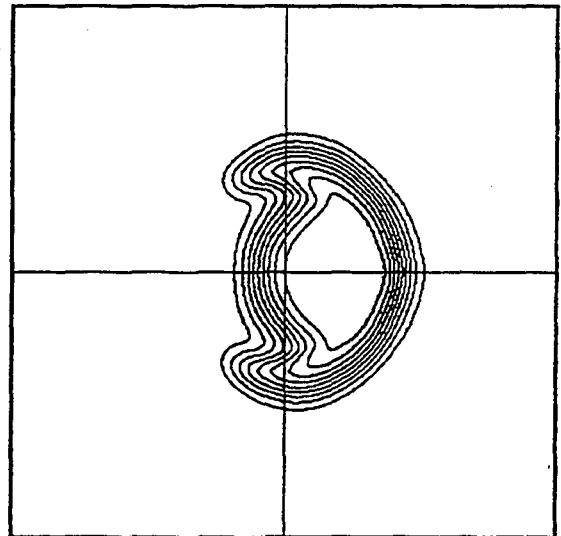

$\tau = 150$

$F = 2, Dc = 0.2, I = 1, V_X = V_Y = 0, R_{in} = 100$

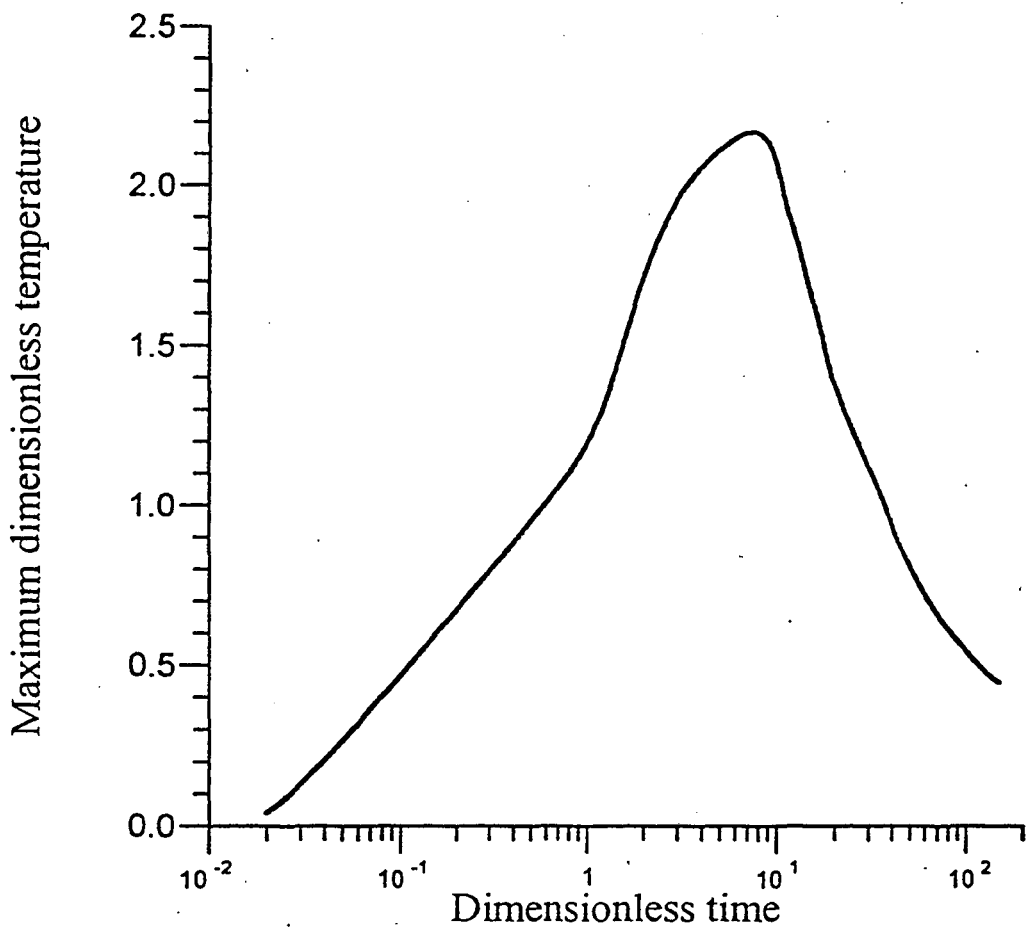

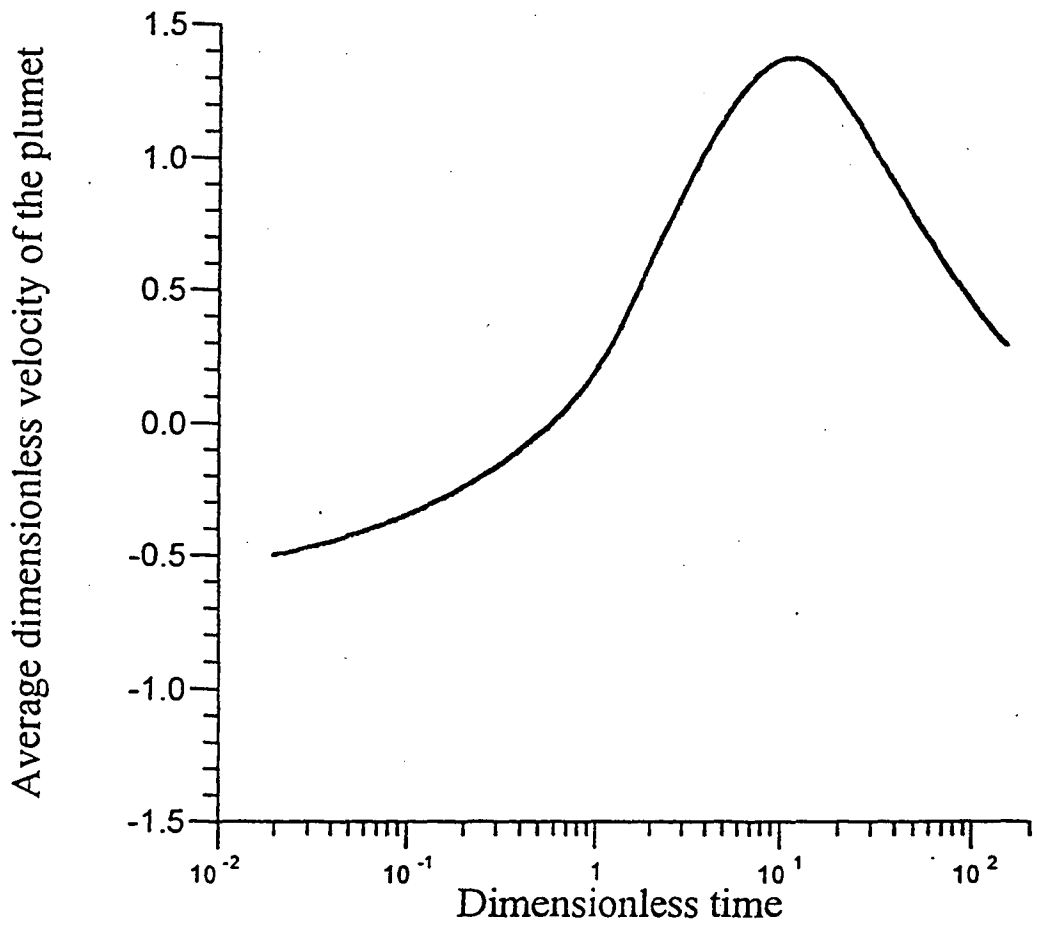

**High level radioactive waste  
Long zone with elevated permeability**

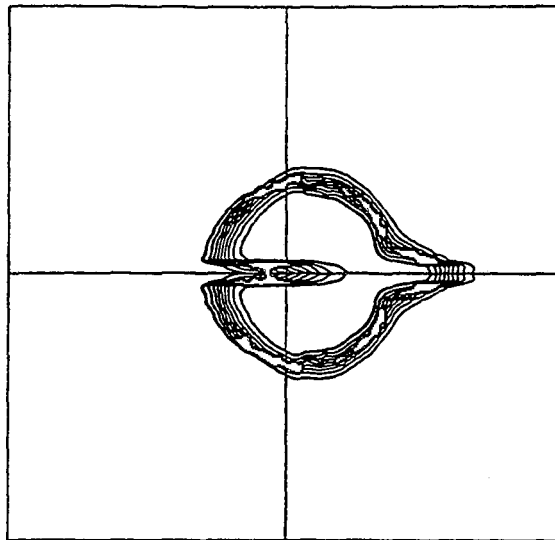

$\tau = 20$

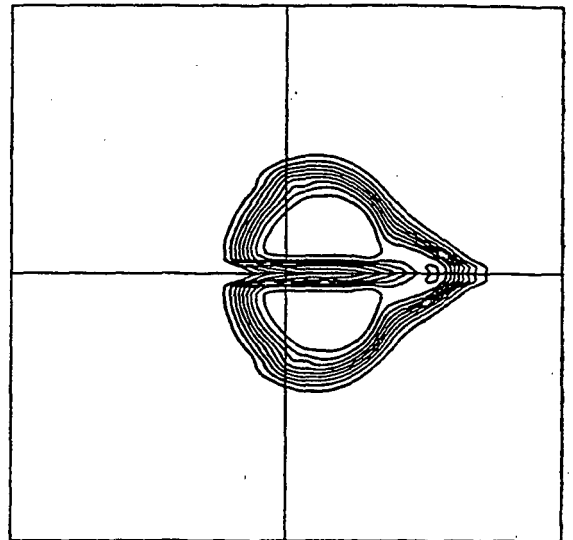

$\tau = 50$

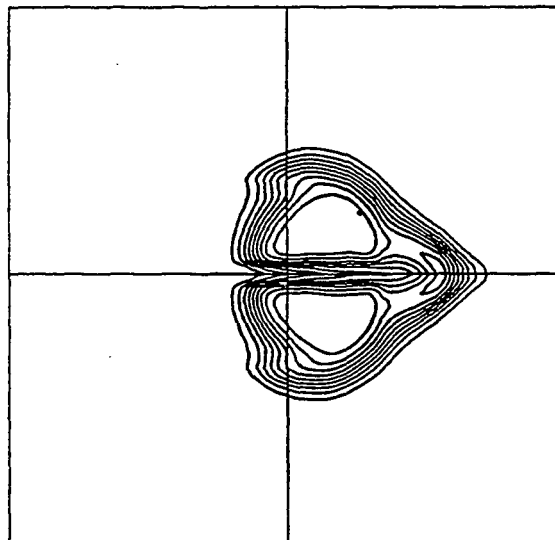

$\tau = 75$

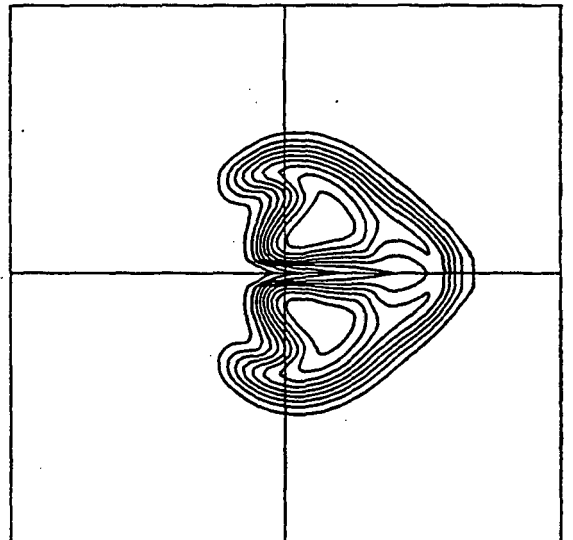

$\tau = 150$

$F = 2, Dc = 0.2, I = 1, V_x = V_y = 0, R_{in} = 100$   
Permeability contrast - 5

## Conclusion

- One of the possible options for enhancement of the long-term safety of such waste disposal system lies in selection of the disposal sites where geochemical conditions provide to “self-cleaning” of injected waste.
- Another possible option for enhancement of the long-term safety of liquid waste disposal lies in using the effect caused by interaction in the disposal system of the different convective transport processes.
- a contributory factor for enhancement of long-term safety of the liquid waste disposal is selection of the injection sites where the interaction between the processes of forced, concentration, and thermal convection provides to suppression of the waste migration
- From generalization of computer simulation results, analytical approximating expressions are obtained which can be used for preliminary selection of disposal site and safety assessment in the case of low level radioactive waste.
- Results of computer simulation show that in the case of essential heat generation in the waste volume, mechanism of contaminant transport process changes what can lead to noticeable deformation of the initial plume shape and changes in velocity (and even direction) of the plume movement. These plume deformations are especially significant due to aquifer permeability anomalies represented by long highly permeable zones aligned with direction of driving forces.

# **Efficient strategy of ground water quality control and remediation at old contaminated sites**

**Mironenko V. A.**  
Russian Academy of Sciences

July 8 - 9, 1997

## **JOINT RUSSIAN-AMERICAN HYDROGEOLOGY SEMINAR**

Russian - American Center for Contaminants Transport Studies  
Ernest Orlando Lawrence Berkeley National Laboratory  
Berkeley, California 94720



In spite of the most extensive practical work and research on ground water remediation, their results are considered more and more skeptically by both public and professionals. The overall situation in this field could be explained by four major drawbacks (fig. 1). Trying to overcome the mentioned drawbacks, we have developed the trial-and-operational approach, — according to our concept of controlled groundwater contamination (fig. 6), which permits the most efficient use of continuous adaptation and feed-back principle (“self-teaching” approach). The major role in this concept is played by groundwater monitoring together with successive hydrogeological forecasts; they are tightly coupled through information by system of models concurrently solving direct, inverse and optimization problems for a given site. A continuous information development makes a real basis for considering the alternative scenarios of remediation including its final goals and risk assessment.

Contrary to the traditional clean-up demands, in our approach the permissible contaminant concentration is associated not with the polluted site on the whole, but with the concrete object (e.g. water intake or spring) under protection, i.e. the real place and tie of ground water usage, which are limited by additional regulations. The necessary control of contaminants pathways and travel times is carried out by groundwater monitoring together with natural mechanisms of contaminants attenuation (fig. 7). Very often these mechanisms make “no action” approach (may be supported by liquidation of contamination source) quite feasible. In other cases natural attenuation could be efficiently combined with long-term containment measures; the more time we have, the more preferable would be such an approach.

As an example, a large oil-productive region in Russia is considered (oil fields in Tataria), which is contaminated by salt water used for oil recovery (fig. 4,5). Before the remediation activity, all the region was divided into areas of 3 types (fig. 9), according to groundwater monitoring data. Special attention was paid to finding out numerous contamination sources (spills due to pipeline leakage) within the unsaturated zone. In so

doing, surface geophysical methods (fig. 10), gaseous survey and biogeochemical (protein content) methods were efficiently used. In spite of strong chloride contamination as well as rather possible old oil spills in the unsaturated zone, the major spring and groundwater intakes in the region still (after 50 years of oil production) give drinking water of good quality, which could be explained by very efficient natural attenuation of contaminants. For better evaluation of the protective properties of the unsaturated zone, special long-term field tests were developed (fig. 11). The active remediation (when it is necessary, in the areas of the third type) is oriented on pump-without treat, for the pumped out saltwater could be injected again into the oil-recovery deep boreholes.

# Major drawbacks of remediation strategy:

- erroneously formulated final goals
- lack of sites priority assessment
- improper allocation of funds between remediation itself and field work for its information support
- poor development of basic concept for remediation optimization, i.e., for assessment “the best” decision among the feasible remediation alternatives (natural attenuation of contaminants, in particular)

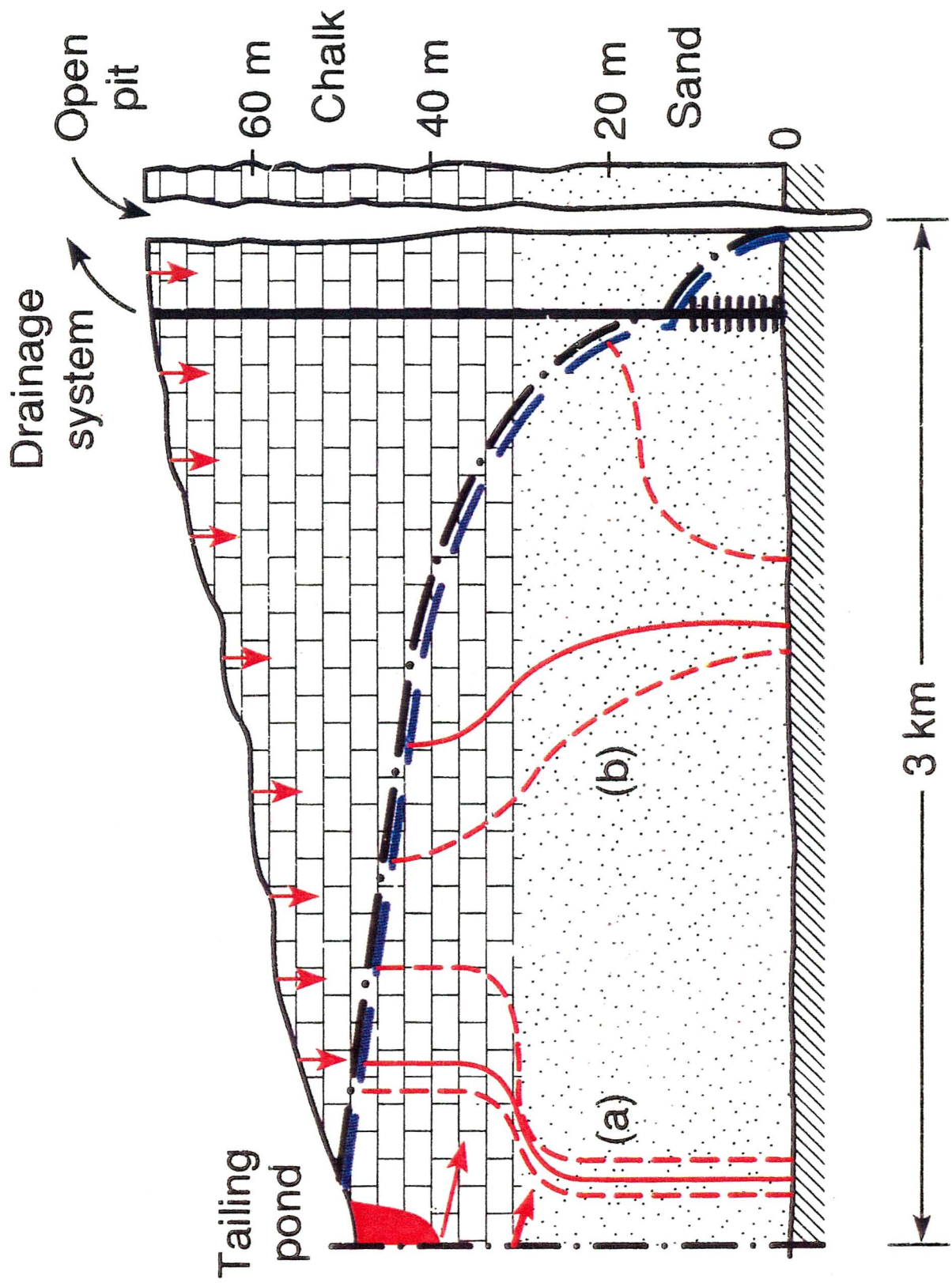

BUGAI ET AL.: COOLING POND OF CHERNOBYL NUCLEAR POWER PLANT

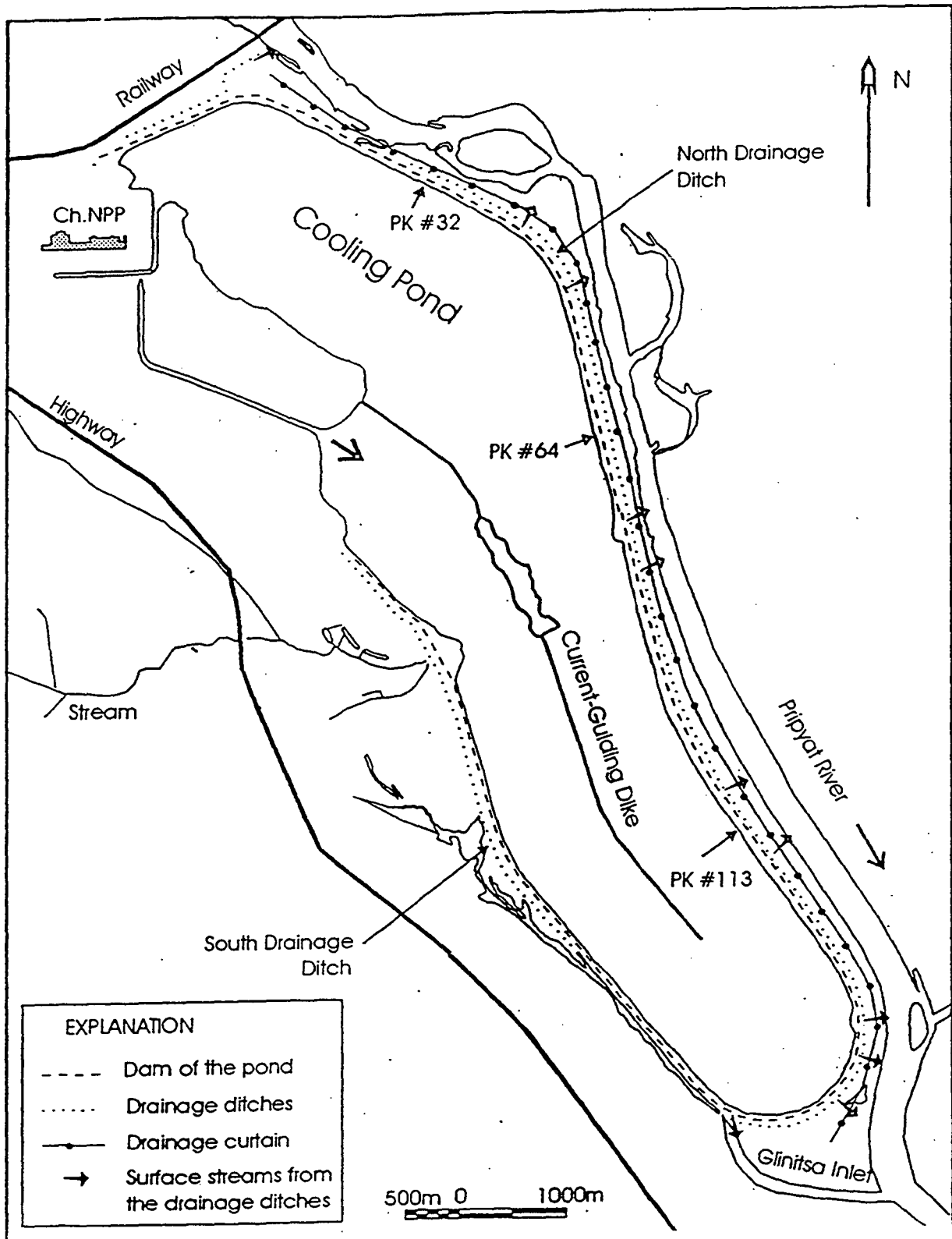

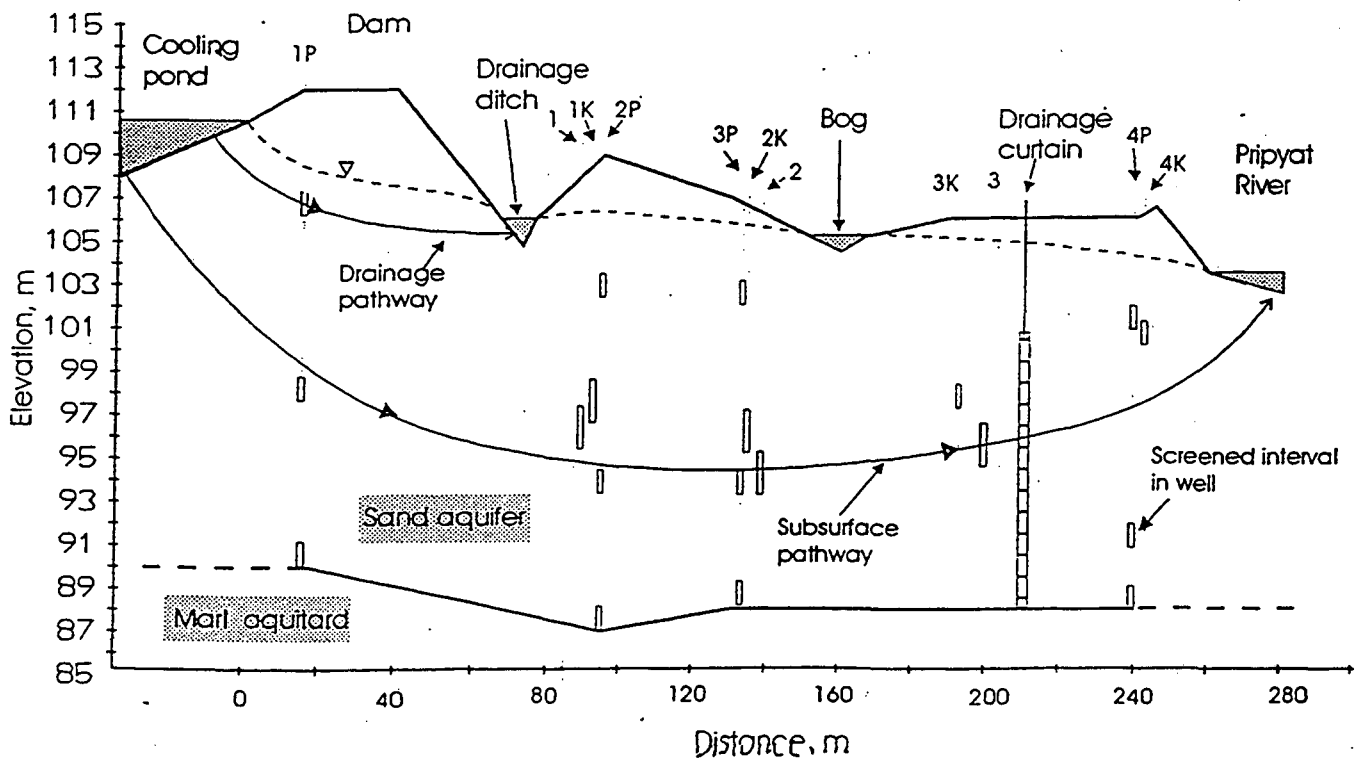

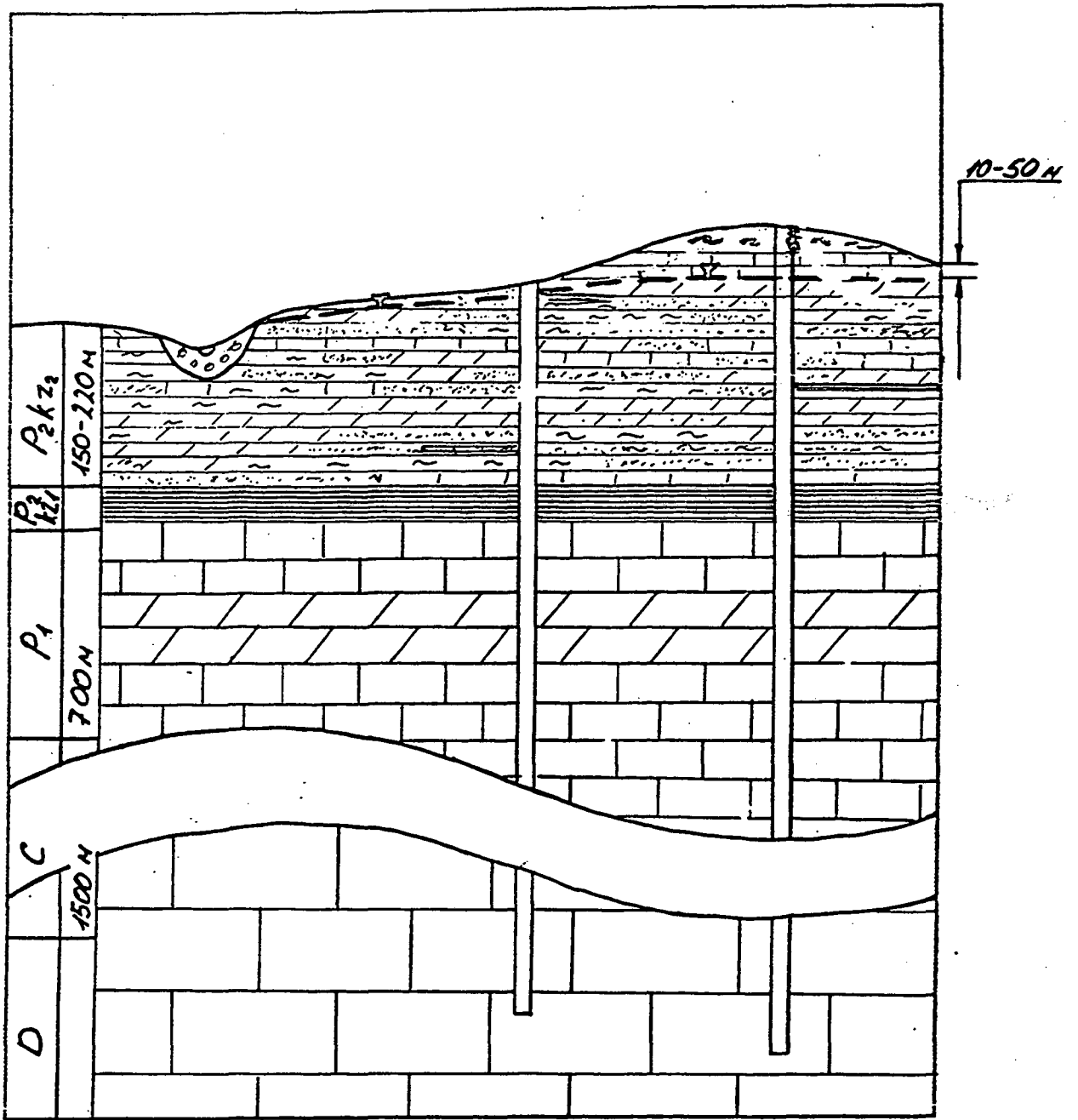

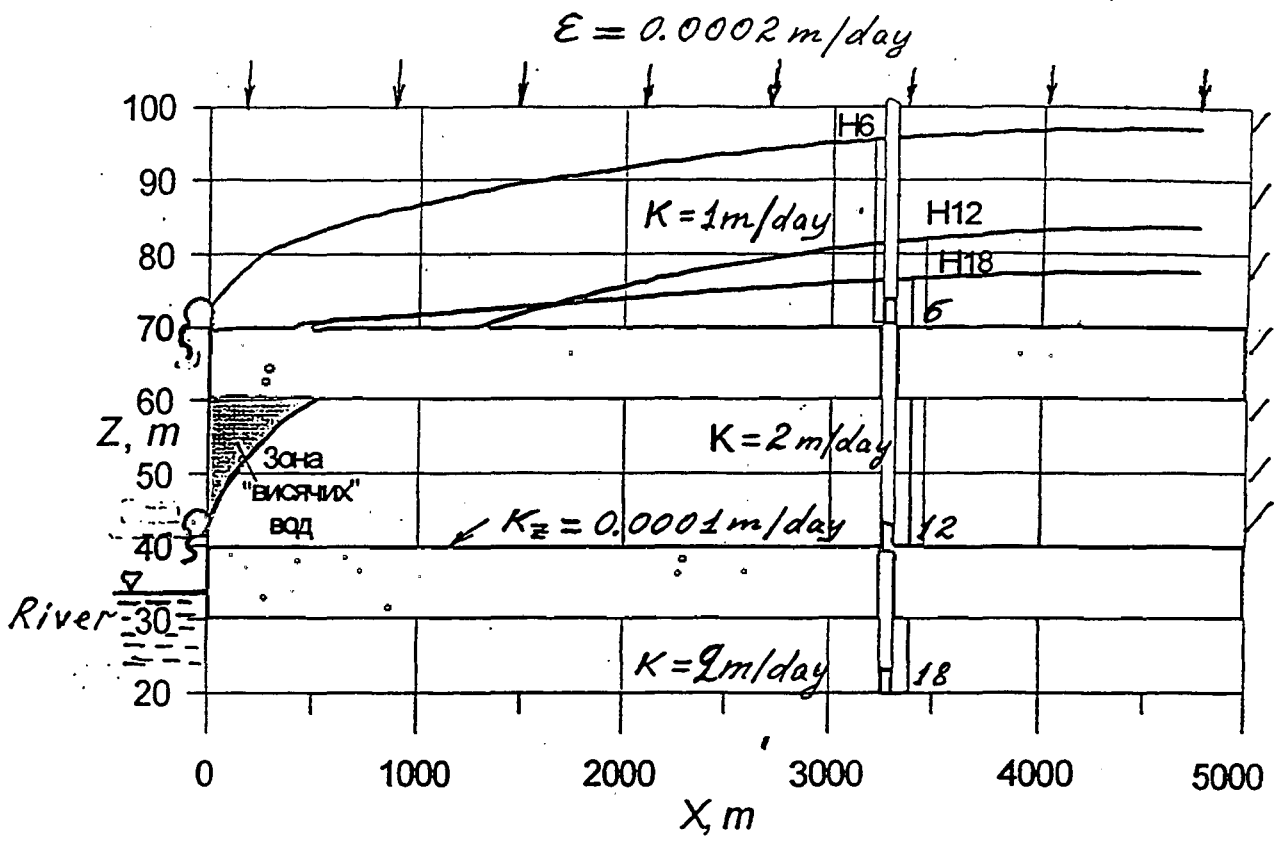



On the concept of controlled ground water contamination.

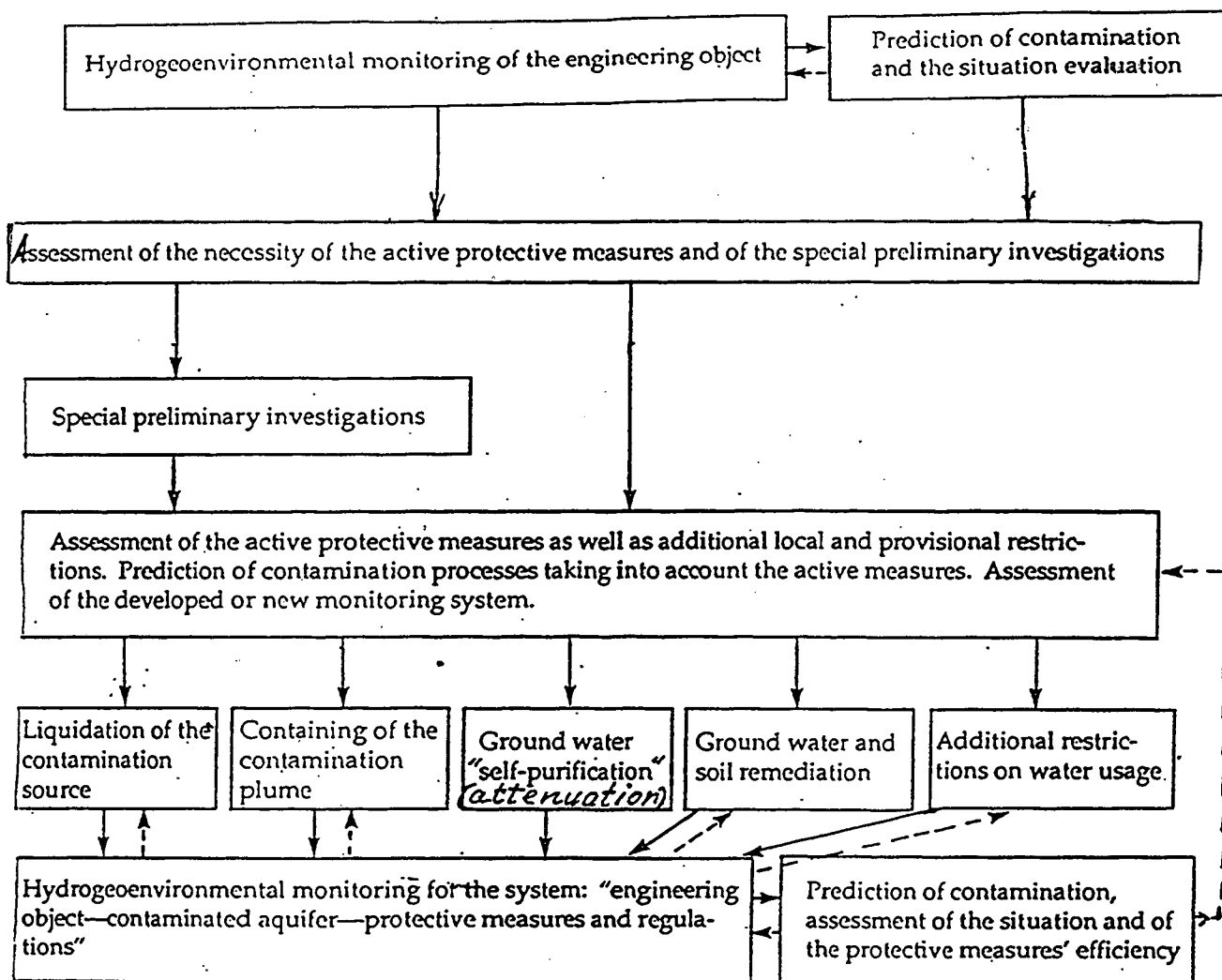

# Mechanisms of natural attenuation of ground water contamination processes

- Dilution and displacement of the contaminated water by the “pure” one (by natural infiltration, in particular)
- Downward flow of the contaminated water (especially for water of higher density) into the deep zones of the waterbearing system, which increases the travel time and storage capacity
- Mechanical dispersion, the transversal one first of all
- Molecular diffusion of contaminants into porous matrix or low-permeable layers, lenses, etc.

# Mechanisms of natural attenuation of ground water contamination processes (cont.)

- Capillary suction of the contaminated water into porous matrix of unsaturated rocks
- Volatilization, transfer of contaminants into the gaseous phase and their upward migration through unsaturated zone
- Physical-and-chemical interaction (exchange) of contaminant water with rock matrix (sorption, ion exchange, precipitation, etc.) *and transformations of contaminants (destruction-decay, complexation, etc.)*
- Biodegradation of contaminants
- Filtration of colloidal and bacterial contaminants, “sieving” effects

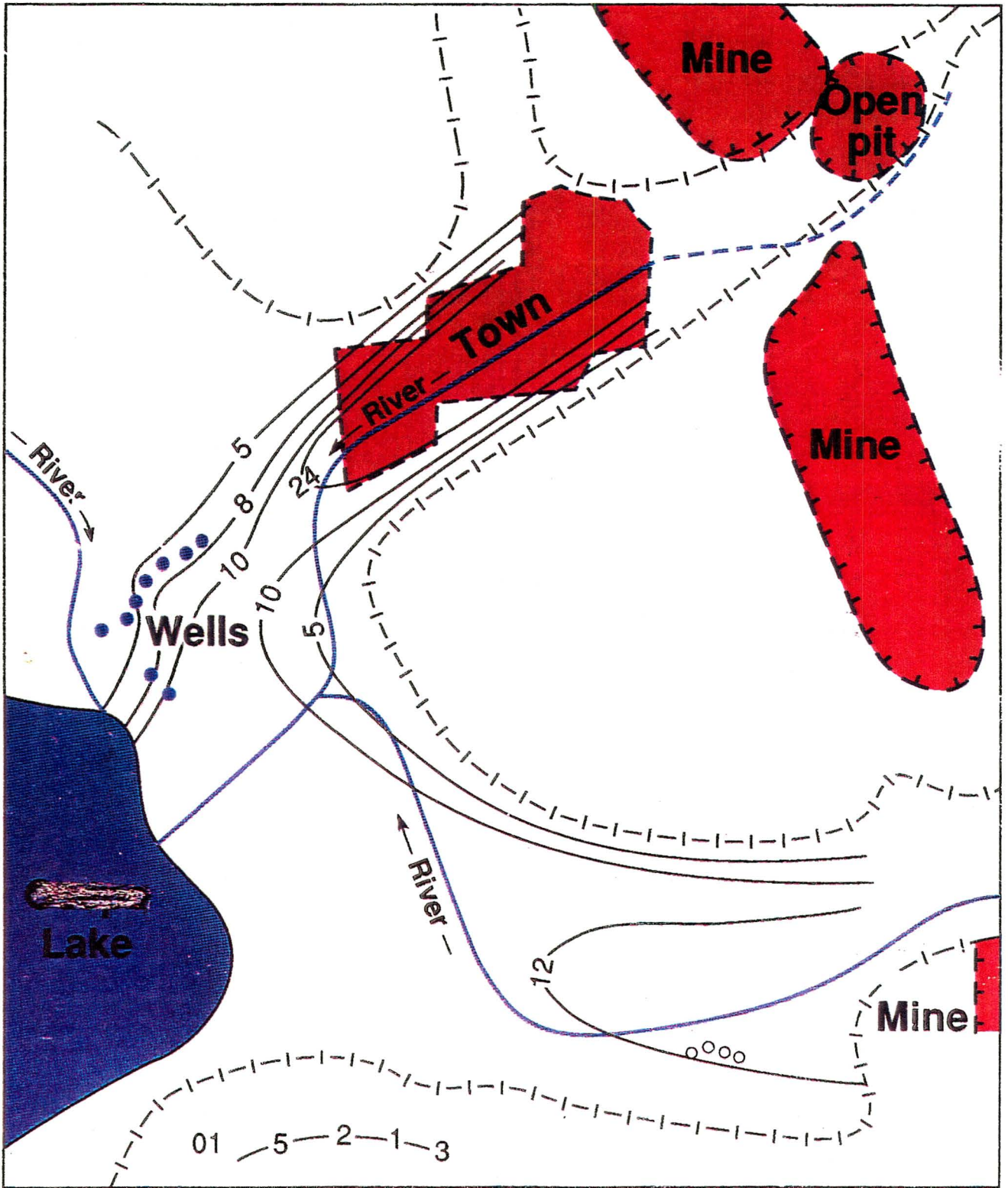

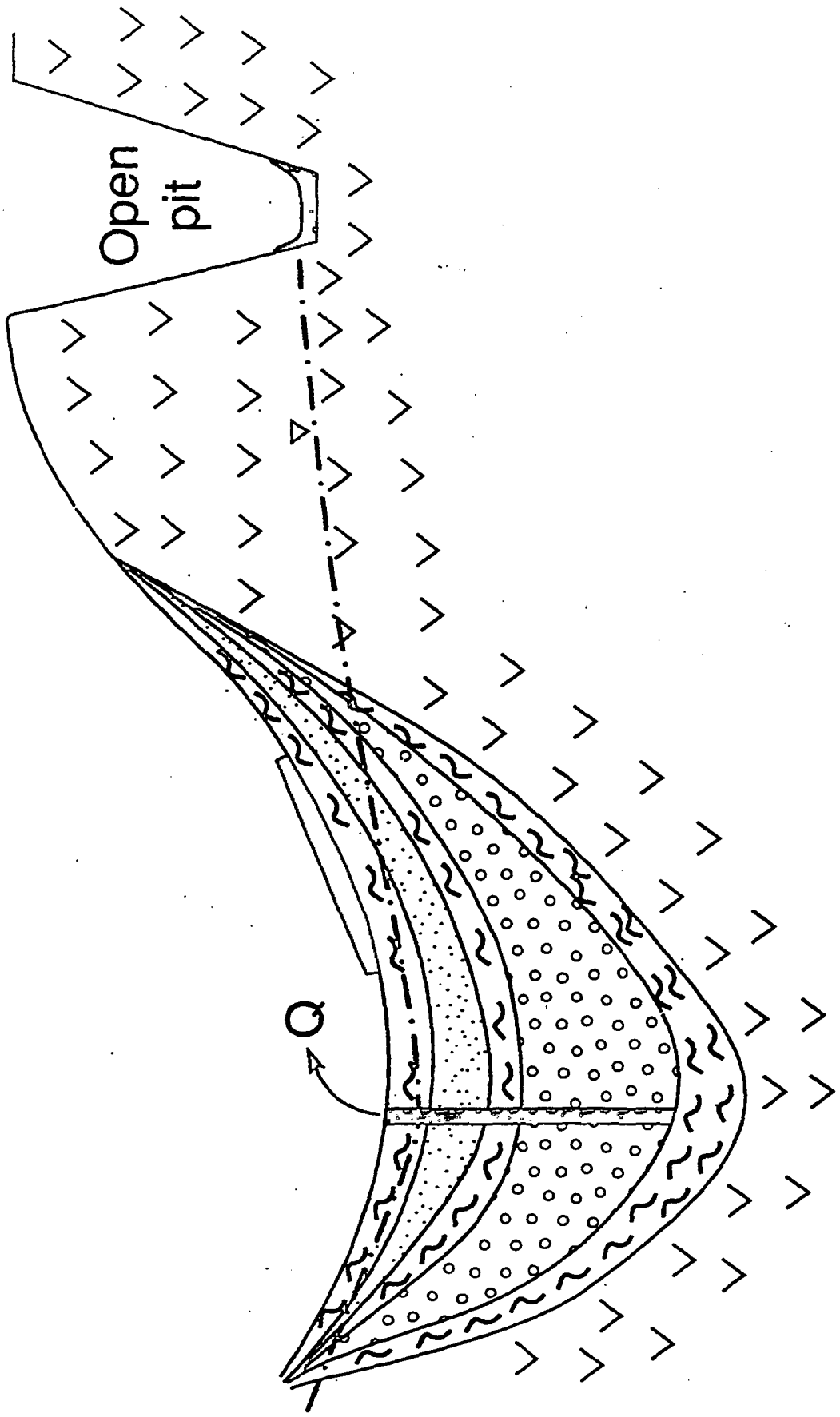

## Sites priorities:

- “pure” areas (no need for remediation)
- “hopeless” areas (remediation is practically unattainable)
- areas, subject to remediation

**План изолиний естественного электрического поля ( по данным полевого модельного эксперимента).**



рис. 6.6

NaCl





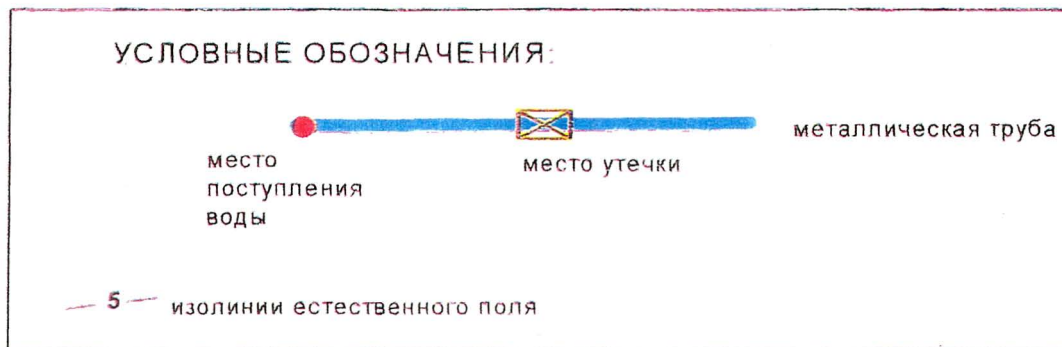
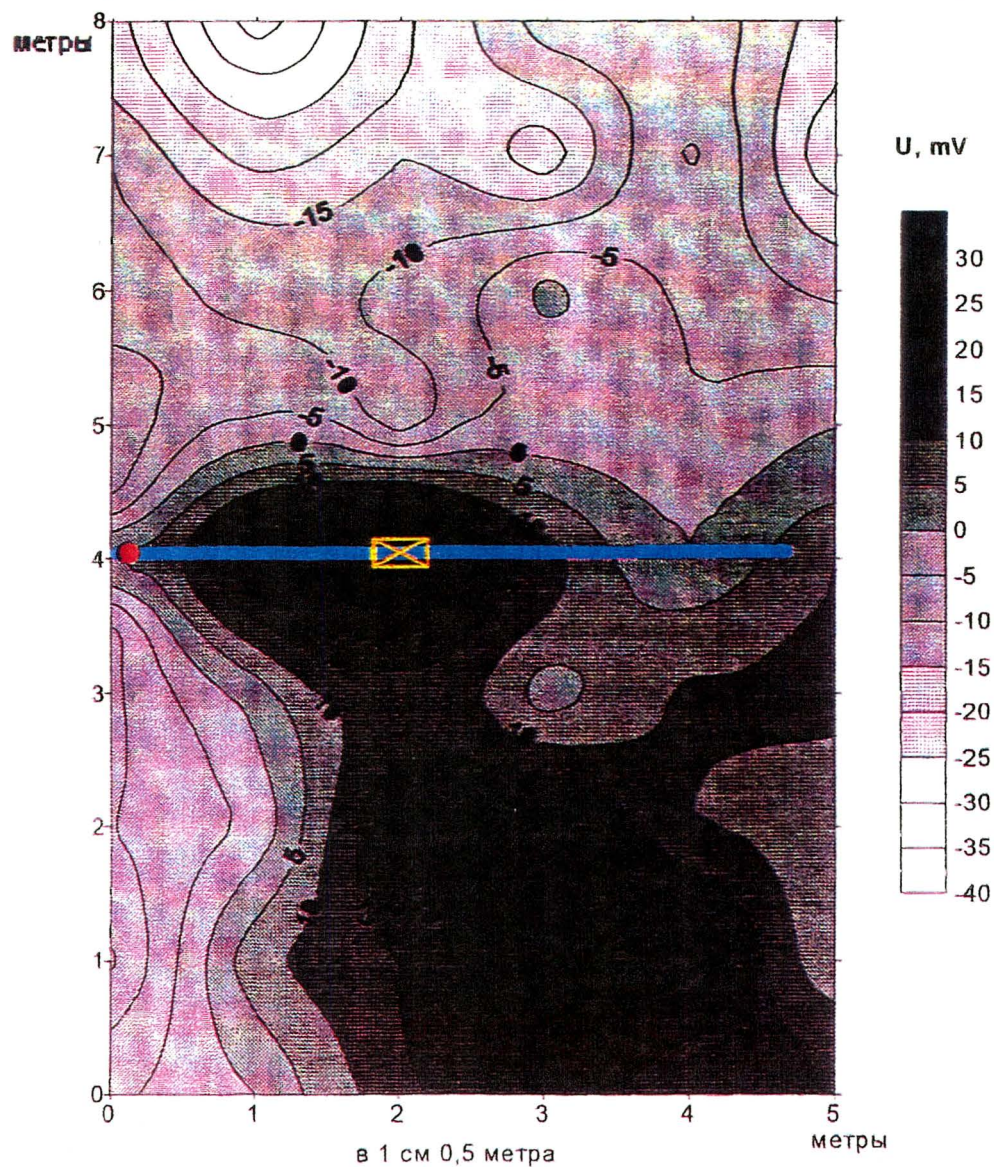
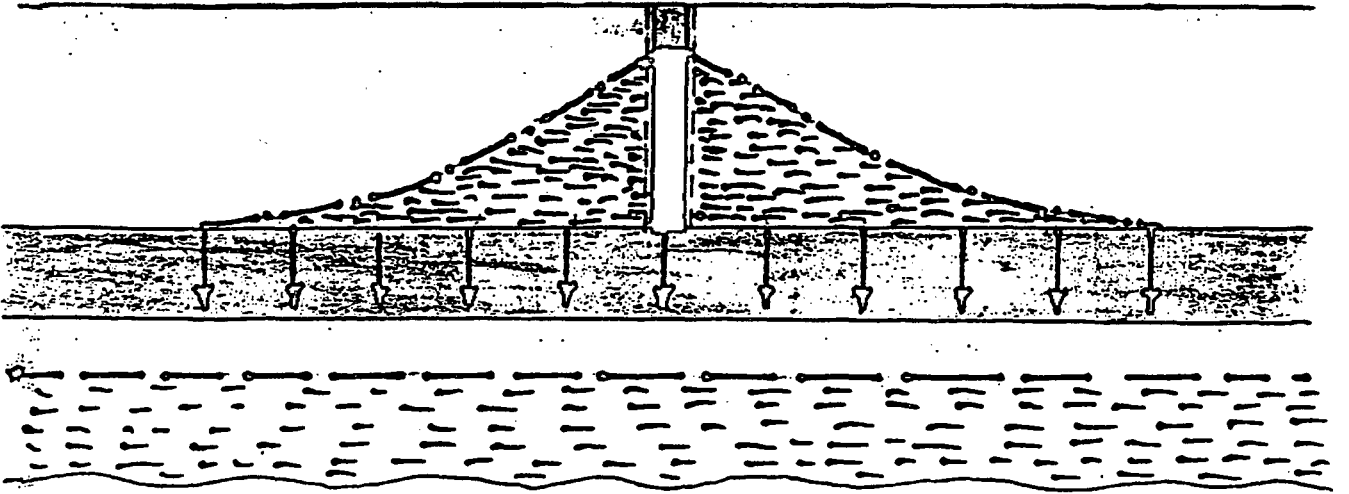
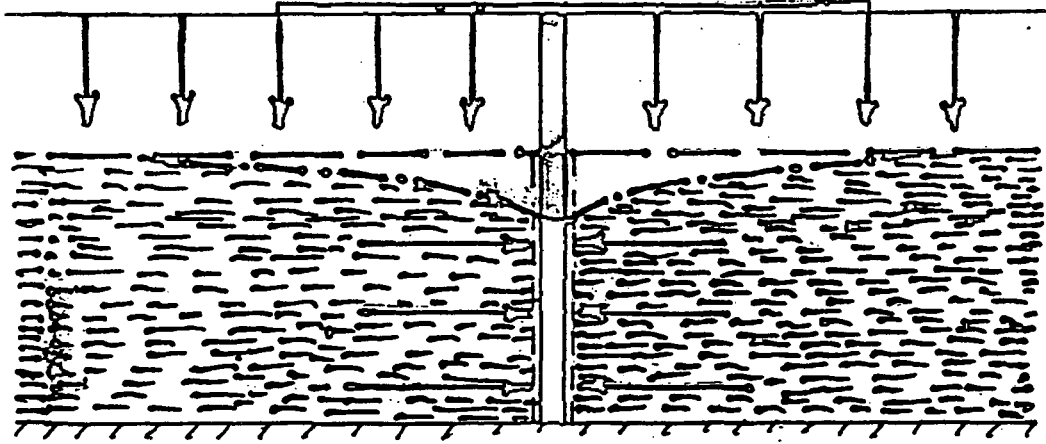
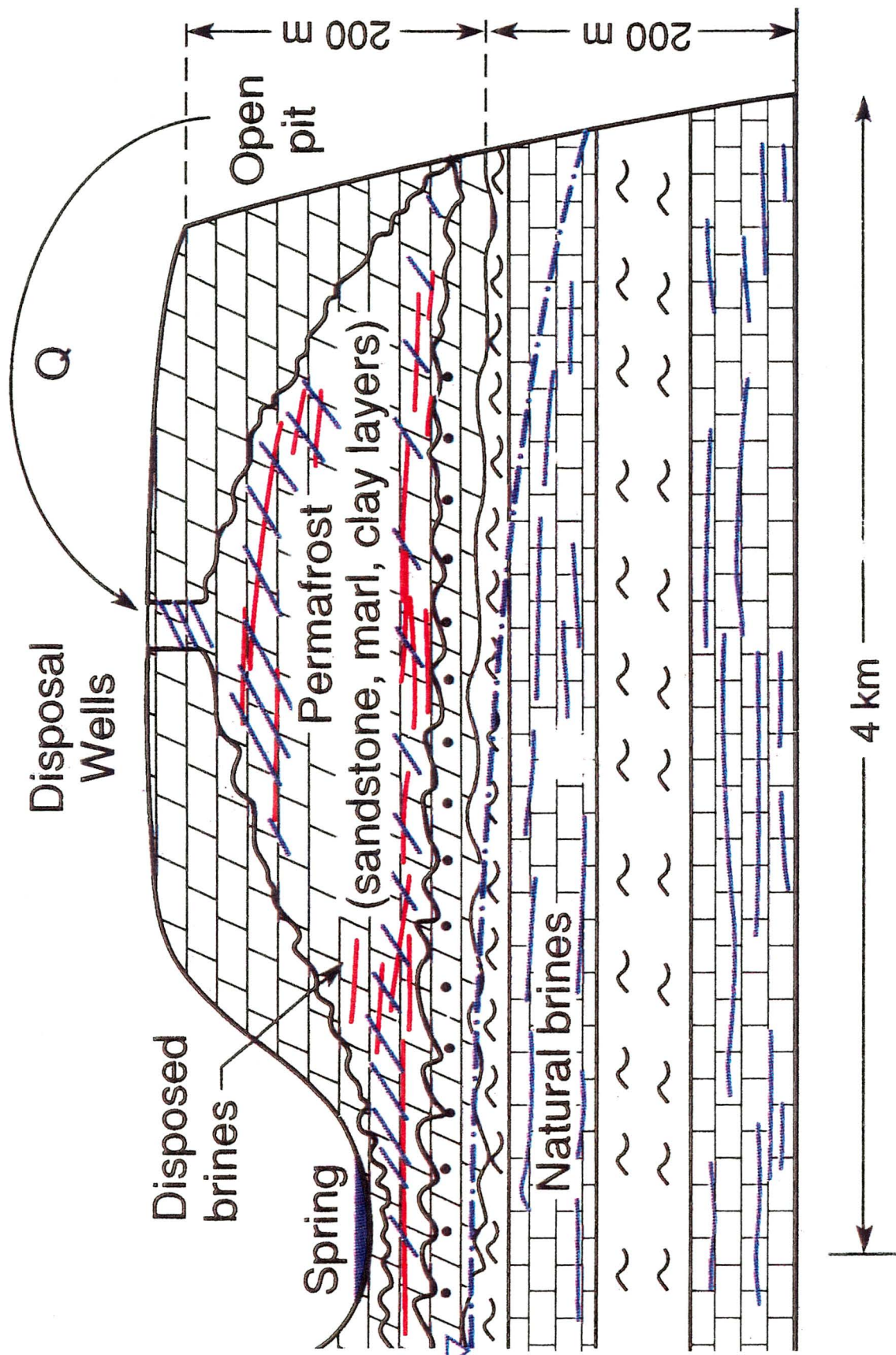

**Salt-water convection in porous media  
on different scales**

**Kuvaev A. A.**  
Moscow State University

July 8 - 9, 1997

**JOINT RUSSIAN-AMERICAN HYDROGEOLOGY SEMINAR**

Russian - American Center for Contaminants Transport Studies  
Ernest Orlando Lawrence Berkeley National Laboratory  
Berkeley, California 94720

The solution of the problem of ground water pollution forecasting and management depends greatly on the possibility of constructing a mathematical model that may be used to substantiate a definitive engineering solution. In a number of cases, primarily in studying highly concentrated industrial pollutants of ground water, a problem arises of a density convection effect on the migration flow dynamics. Computation of density convection in a migration model of hazardous wastes in aquifers is an important problem in hydrogeological investigations. It is known that density convection in migration causes the fingering of a pollution front on the micro- and macro-levels. This effect greatly influences the hydrodynamic structure of the flow. The investigation shows that formation of a finger system results from the vortex structure of a hydrodynamic field, reinforced by density convection. Two scales of fingers should be distinguished:

- micro-fingers caused by the stochastically micro-inhomogeneity of the hydrodynamic field;
- macro-fingers caused by macro-inhomogeneity of the hydrodynamic field.

Figure 1 shows the results of the experimental investigation of the visible salt water front configuration in a vertical porous column in a homogeneous medium for different times (in minutes). Waters with different input salinities were marked with color, then injected through the upper section of the column . It was observed that fingers appear only when injected water has non-zero salinity.

Figure 2 shows the comparison of the experimental data (average in horizontal cross-section salinity) with the results of one-dimensional numerical modeling. As we can see in this case, the traditional model of hydrodynamical microdispersion is not useful. The salt-water front dispersion is reinforced by fingering.

A two-dimensional numerical model, based on a particle-tracing technique, was developed to investigate miscible fingering. The resulting numerical model is used for simulation of variable density groundwater flow for a real natural situation: infiltration of the hazardous wastes

from an industrial storage basin. The modeling was carried out for two variations of contamination input:

- through the top of the aquifer directly from a storage basin (variant 1);
- through the bottom of the aquifer in accordance with the often used scheme of immiscible fluids (variant 2).

The results of modeling of two-dimensional migration of fluid with salinity 86 g/l from an industrial storage basin are shown in Figure 3. It is apparent that vertical mixing is significant in variant 1. Comparatively low salinity results in this kind of mixing. The aquifer's salinity below the basin doesn't exceed 25% of its preliminary salinity. Lateral migration of contamination is taking place together with natural groundwater flow. The opposite was observed in variant 2, where the clear (contrasting) interface of salt- and fresh water exists. Lateral migration of contamination is proceeding considerably faster. The model discussed in variants 1 and 2 does not consider density microdispersion of fluids. The theoretical model of this effect for ground water large-scale flow has not yet been developed. We can only predict that density microdispersion will cause more fluid mixing in the aquifer.

Density convection appears to define a hydrodynamical situation of fluids in deep aquifers with relatively small gradients of ground water heads. It is known that some deep artesian basins are characterized by anomalous distributions of ground water salinity in vertical section, regardless of the presence of halite. A maximum value of salinity for this region is observed in a specific depth interval. Above or below this depth interval, the salinity of ground water is considerably lower. The layer of more salty water is characterized by its higher density; above it, less salty ground water is hydrodynamically unstable. In such situations density convection must appear, resulting in the redistribution of density and, consequently, mixing of salt- and fresh water.

Testing of a hydrodynamical model of a deep aquifer with an anomalous distribution of ground water salinity in vertical section was considered for the Pechora site in northern

Russia. In this model, part of the cross-section was investigated. This part of the section is overlain by the layer of clayey Kungur-strata of lower Permian age, a low permeability cover for oil-deposits. The base of the clays lies at a depth of about 2000 m. From below, this part of the section is limited by the strata of relatively impermeable Middle Devonian clays and argillites, with their top at depths of about 5000 m. Permeable rocks are present, mainly as Devonian-Cretaceous limestones and sandstones. At this site, according to existing data, anomalous high pressures and temperatures are absent, that might otherwise indicate inflows of fluids through Middle Devonian clays and argillites.

The generalized observed distribution of ground water salinity in vertical section shows, that in the middle part of the permeable strata, salinity is up to 180 g/l, while at the top and the bottom it varies from 30 to 50 g/l. Typical filtration parameters for deep aquifers are used for this kind of modeling. As an initial condition, the generalized observed distribution of ground water salinity was assigned as an empirical function. For initiating density convection at certain locations of the area, random deflections of salinity from the generalised one were assigned.

The results of modeling for two considered variants are apparent in the Figure; they differ in filtration parameters of permeable strata. Fluid with high salinity migrates downwards as fingers, but fluid with lower salinity moves upwards. Redistribution of salt and fresh water in the vertical section occurs in about 1 million years.

An important result of this modeling is that the salinity anomaly cannot exist more than several million years. This conclusion can greatly change theories of the development of deep hydrogeological processes. Improvement of industrial ground water contamination forecasting, development of monitoring and management of high density fluids in groundwater, and hydrodynamical models of deep aquifer systems greatly depend on the progress in mathematical models of density convection. The most important problem in this process is the evaluation of the "fingers-scale" ground water flow.

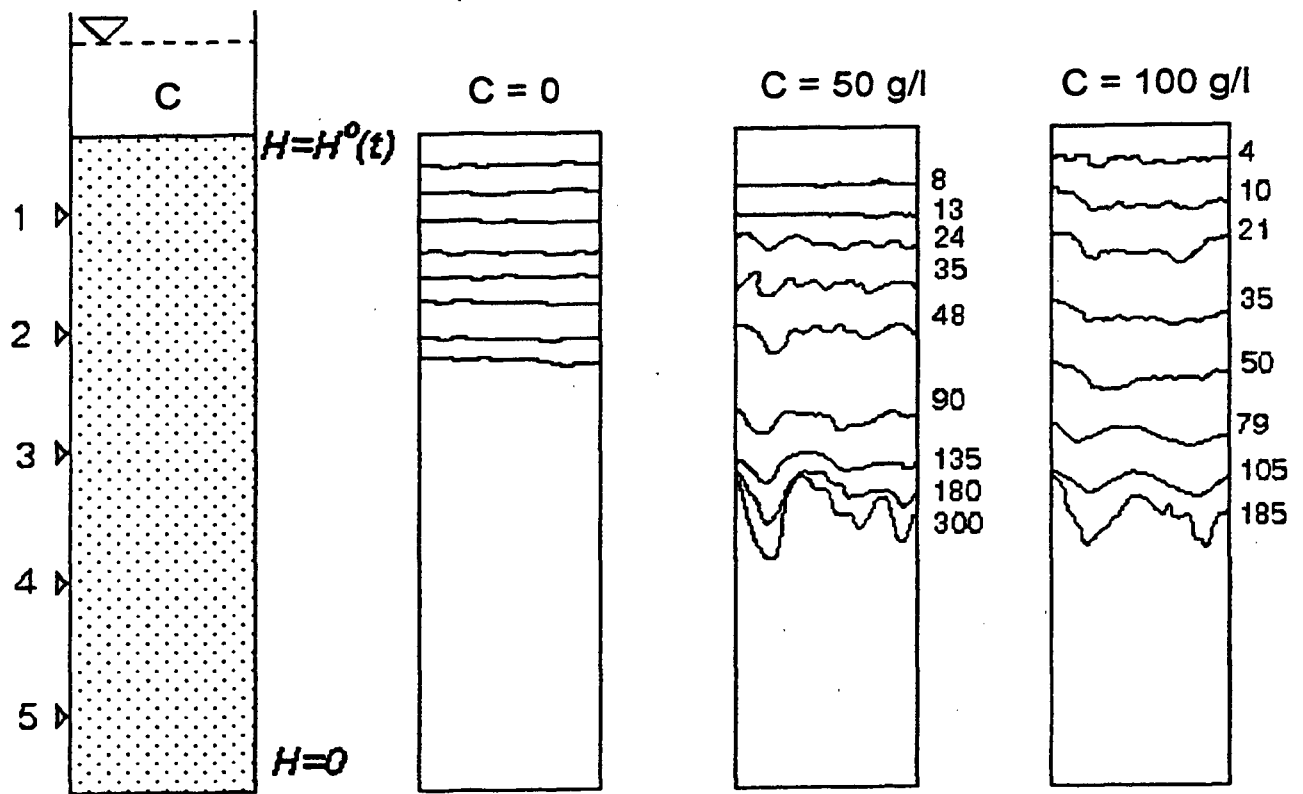
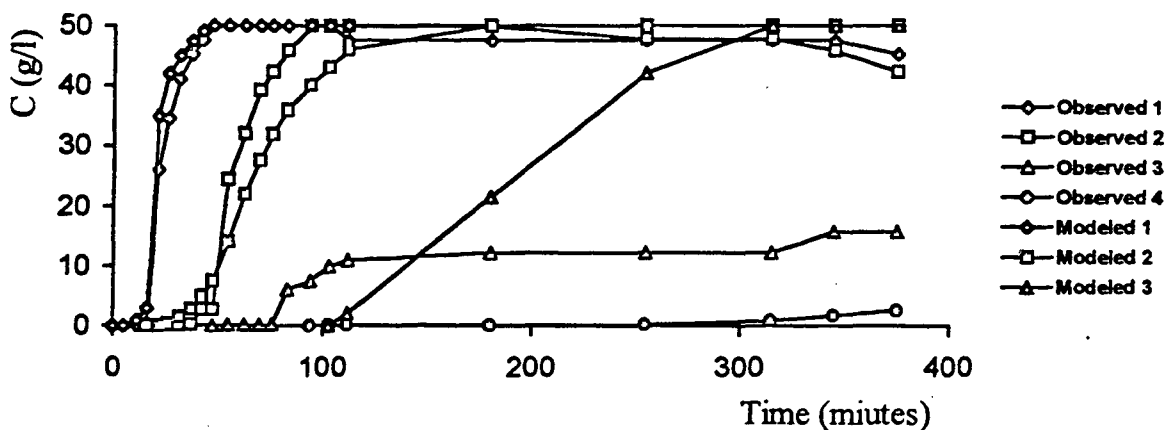

Figure 1. Results of the experimental investigation of the visible salt front in a vertical porous column

### Experiment 2



### Experiment 3

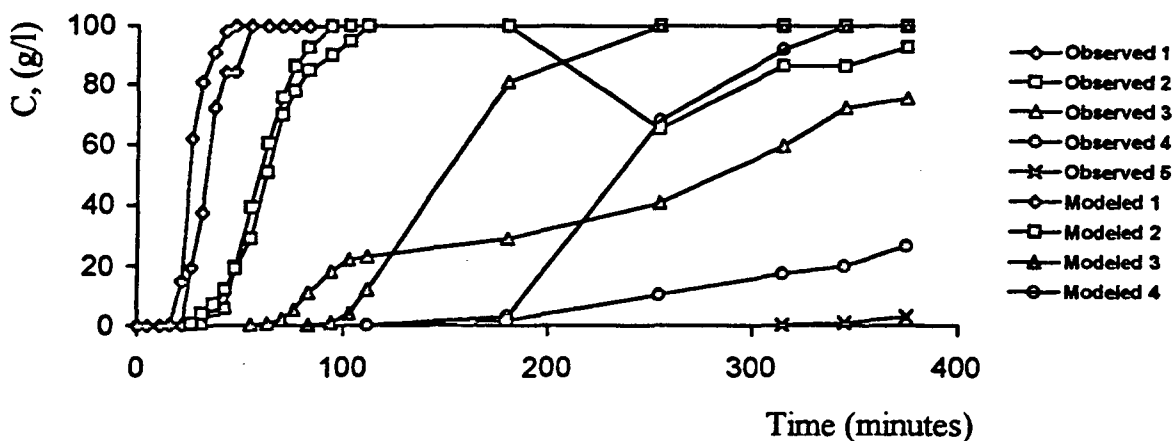

Figure 2. Comparison of the experimental data (average in horizontal cross-section salinity) with the results of one-dimensional numerical modeling

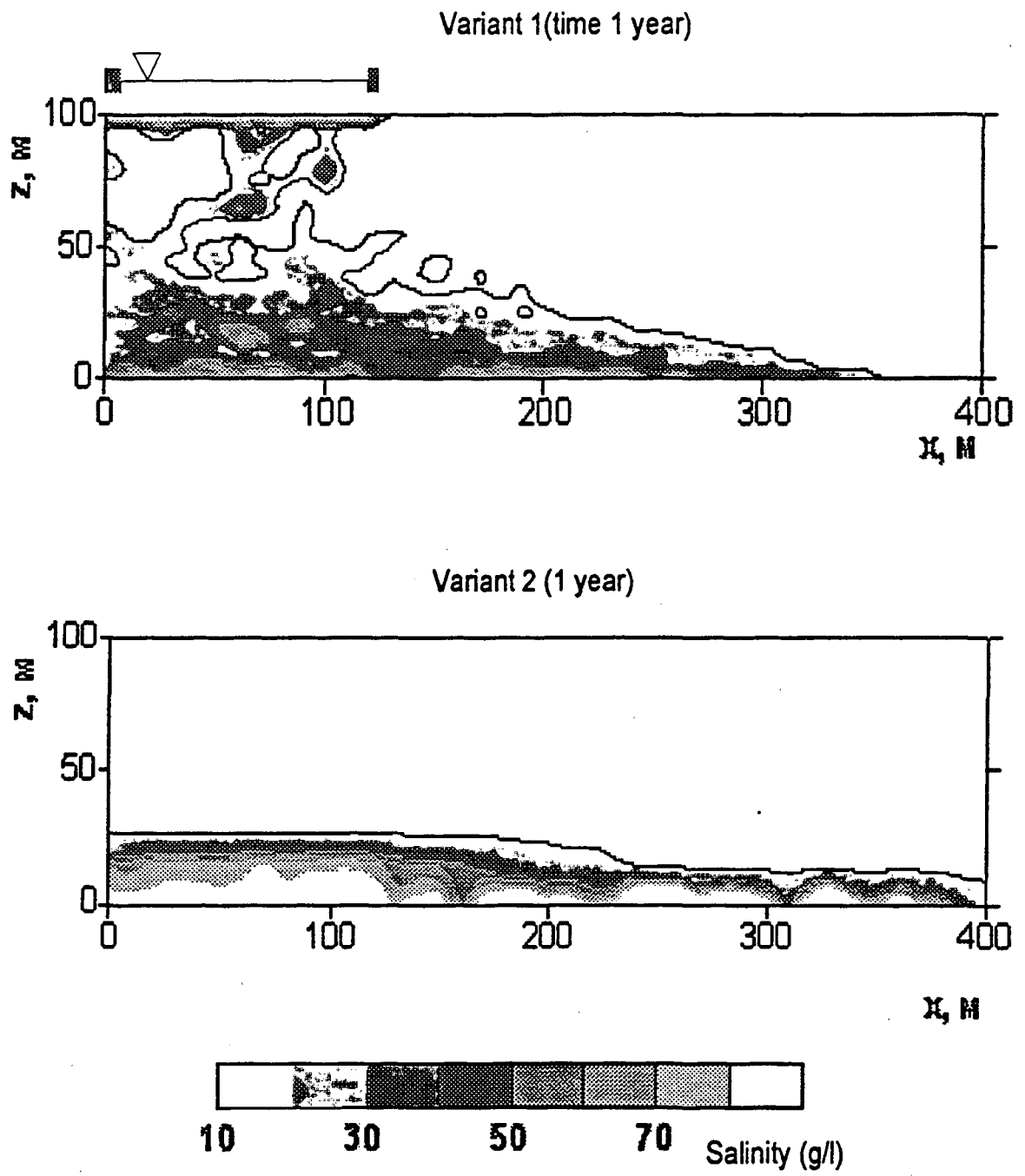
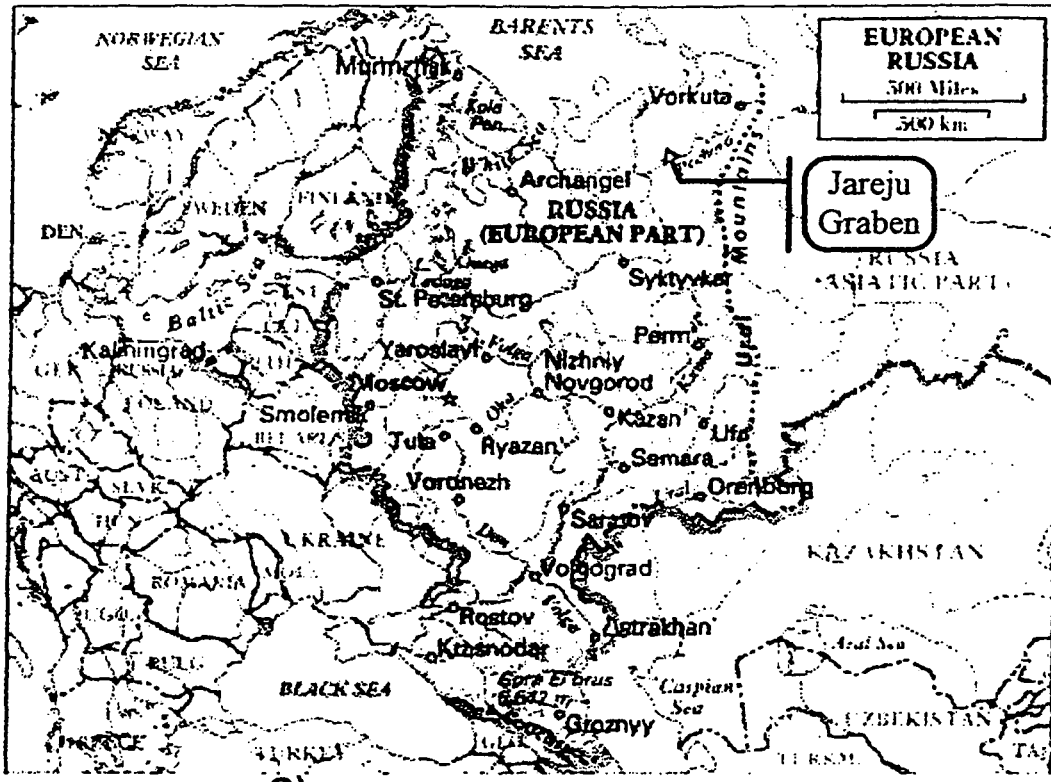

Figure 3. Results of modeling of two-dimensional migration of fluid with input salinity 86 g/l from industrial storage basin





a)

b)

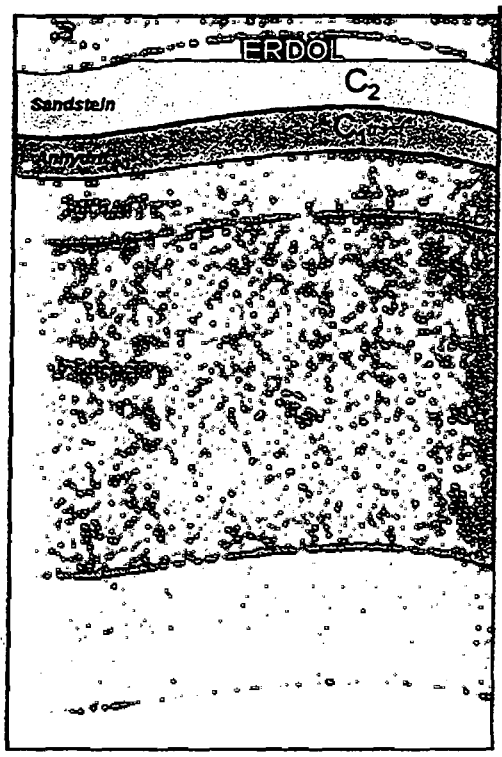
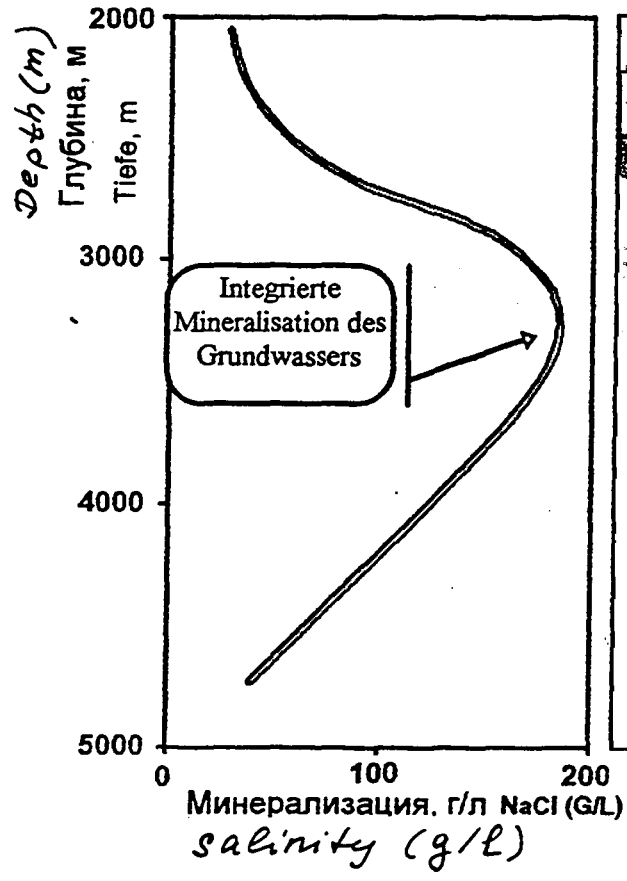

10000 m

Results of the 2D-modeling of the salt-water convection in a deep aquifer

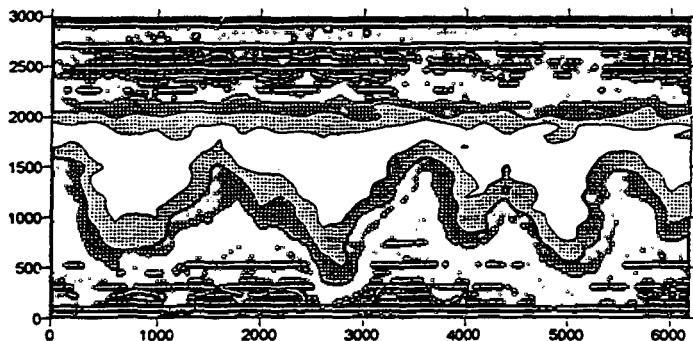

1.2 млн. лет

$1.2 \cdot 10^6$  years

VARIANT ①

ВАРИАНТ 1

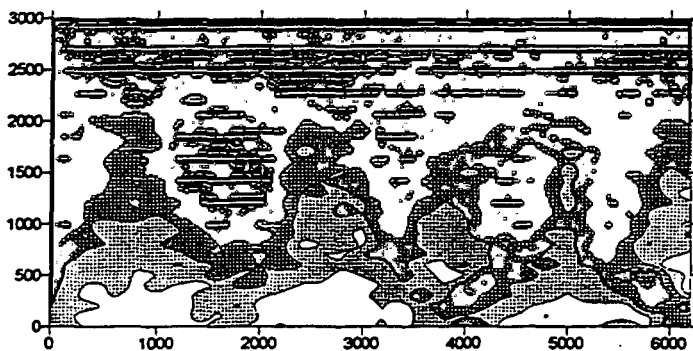

3.5 млн. лет

$3.5 \cdot 10^6$  years

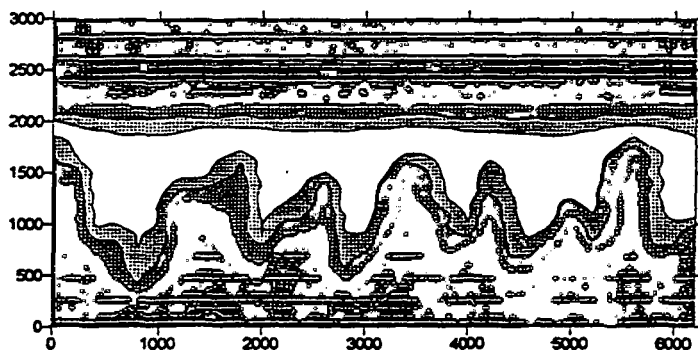

200 тыс. лет

$2.0 \cdot 10^5$  years

VARIANT ②

ВАРИАНТ 2

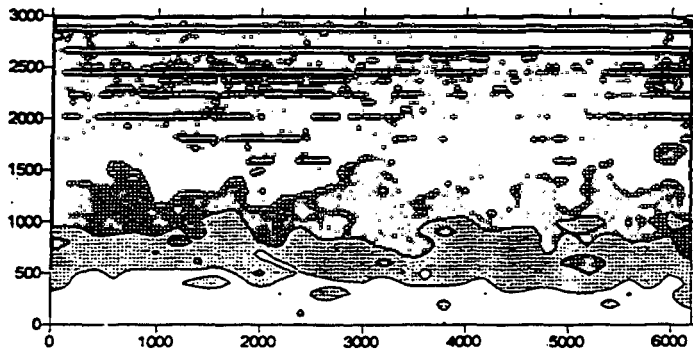

500 тыс. лет

$5.0 \cdot 10^5$  years

# **Modeling of ground water contamination caused by organic pollutants**

**Pashkovsky I. S.**  
Russian-Swedish Joint Venture GEOLINK

July 8 - 9, 1997

**JOINT RUSSIAN-AMERICAN HYDROGEOLOGY SEMINAR**

Russian - American Center for Contaminants Transport Studies  
Ernest Orlando Lawrence Berkeley National Laboratory  
Berkeley, California 94720

Groundwater vulnerability from natural and human impacts greatly depends on climate, soil, and unsaturated zone conditions. For many different pollutants ( heavy metals, organic chemicals, including pesticides and hydrocarbons, radioactive contaminants, bacteria and viruses) the soil and the unsaturated zone are the first and in some cases nonpermeable barriers which protect groundwater from contamination.

Many processes such as sorption, oxidation-reduction reactions, biotransformation, cation exchange and others take place in unsaturated zone. The adsorption-desorption and ion-exchange reactions cause retardation of the contaminant with respect to pore water. So heavy metals and radioactive nuclides can be completely held in the soil and unsaturated zone. Decomposition of primary organic compounds ( hydrocarbons, halogenated hydrocarbons, pesticides, etc.), is caused by microorganisms, which obtain the carbon and hydrogen for their cell synthesis. Decay processes are dependent on temperature and moisture content in soil and thus on climatic conditions.

The model consists of five elements: climate, boundary conditions, heat, moisture and solute transport in the unsaturated zone. A key feature of the model is its treatment of snow cover, freezing of water and frost depth, which greatly influence surface and ground water runoff in regions with cold climates such as Russia, using real or synthetic records of the climatic data (precipitation and temperature).

The monthly temperature and precipitation are calculated as:

$$T_i = T_i^0 + \sigma_T \xi \quad (1)$$

$$O_i = O_i^0 + \sigma_O \xi \quad (2).$$

Where  $T_i$  and  $O_i$  are calculated monthly temperature and precipitation, and  $T_i^0$ ,  $O_i^0$  are real monthly mean temperature and precipitation, and  $\sigma_T$ ,  $\sigma_O$  are their standard deviations,  $\xi$  is random number with normal distribution.

Every type of landscape is characterized by coefficients, which determine the rate of the snow melting -  $\alpha$ , interception -  $\beta$  and evapotranspiration -  $\gamma$ .

To solve the problem we use the finite difference method, so the unsaturated zone is gridded into cells for model computation, and input parameters are defined by characteristics of the rocks. An interpolation subroutine estimates the moisture content in the unsaturated zone, its temperature and concentration of the pollutant.

**EXAMPLE**

Depth to water table.....	2.4 m
Porosity .....	0.45
Residual water content.....	0.15
Height of capillary fringe.....	1 m
Saturated conductivity.....	0.5 m/day
Soil-water distribution coefficient.....	1.2 L/mg
First- order decay coefficient at 20 ° C.....	0.003 1/day
Initial concentration of benzene up to depth 0.45 m ...	100 mg/L

**MOISTURE TRANSPORT MODEL**

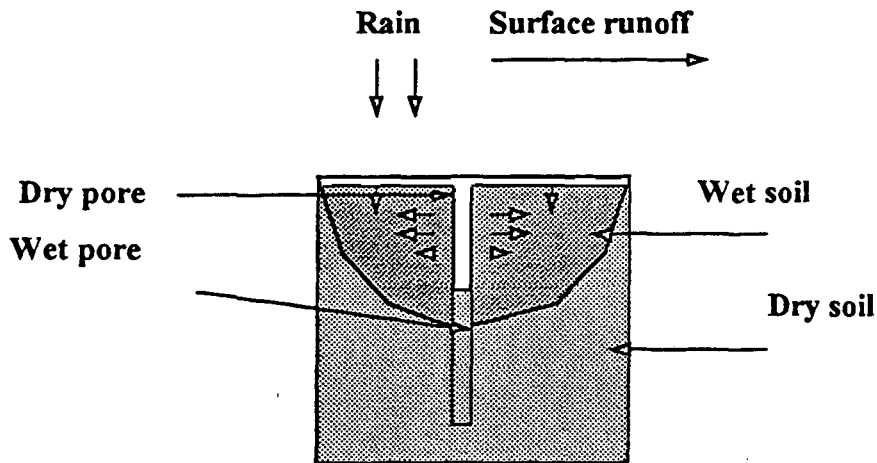

$$\frac{\partial}{\partial z} \left( k \frac{\partial H}{\partial z} \right) + E = C \frac{\partial H}{\partial t} - \frac{\rho_i}{\rho_w} \frac{\partial J}{\partial t} + \frac{1}{\tau} (\theta_m - \theta)$$

where:

$H$  is hydraulic head ( $H = P/\rho_w + z$ )

$z$  is elevation of the base of the piezometer,

$J$  is volumetric ice content,

$E$  is intensity of issues (root sucking),

$\tau$  is character time of moist exchange between blocks of the soil and large pores,

$\theta$  is volumetric moisture content:

$$\theta = \theta_o + (\theta_m - \theta_o)(1-J) \exp(P(1-J)/H_k),$$

$\theta_o$  is hygroscopic moisture content,  $\theta_m$  is porosity,

$\rho_w, \rho_i$  - water and ice density,

$k$  is permeability  $k = (k_o \frac{\theta - \theta_o}{\theta_m - \theta_o})^n / (1 + 8J)^2,$

$C$  is the specific storativity ( $C = \frac{\partial \theta}{\partial P}$ , when  $P < 0$  and  $C = 0$ , when  $P > 0$ ):

$$C = (\theta_m - \theta_o)(1-J)^2 / H_k \exp((P(1-J)/H_k),$$

#### HEAT TRANSPORT MODEL

$$\frac{\partial}{\partial z} (\lambda(\theta, J) \frac{\partial T}{\partial z}) + c_w \frac{\partial vT}{\partial z} = c_o \frac{\partial T}{\partial t},$$

where:

$T$  is temperature,

$$C_o = C_{sc}(1-\theta_m) + C_w \theta + C_i J - L \frac{\partial J}{\partial T}$$

$C_w$  is the specific heat of water,

$C_{sc}$  is the specific heat of soil grains

$C_i$  is the specific heat of ice,

$L$  is the specific heat of melting,

$\lambda(\theta, J)$  is the thermal conductivity,

#### SOLUTE TRANSPORT MODEL

$$\frac{\partial}{\partial z} \left( D(v, \theta) \frac{\partial C}{\partial z} \right) - \frac{\partial v C}{\partial z} = \frac{\partial Q}{\partial t} + \varphi(\theta, T) Q$$

where:

$Q = C(\theta \delta + K_{i_d})$  is the total content of contaminant in mg per kg of dry soil,

$K_{i_d}$  is the soil-water distribution coefficient,

$\varphi(\theta, T)$  is the first-order decay coefficient for component in the unsaturated zone:

$$\varphi(\theta, T) = \varphi_o \left\{ \exp\left(\frac{\theta - \theta_o}{\theta_m}\right)^2 + \exp\left(\frac{T - T_o}{T_m}\right)^2 \right\};$$

where  $\theta_o, \theta_m, T_o, T_m$  are constants;

$D(\theta, v) = \chi v (\theta - \theta_o)^n$  is dispersion coefficient,  $\chi$  is longitudinal dispersivity.

#### REFERENCES

Burlin, M. Yu., L. A. Panova, and I. S. Pashkovsky, The Software System for Modeling Groundwater Flows and Migration in Saturated/Non Saturated Rocks. in: *Proceedings of the Workshop on Hydrogeology/Environmental Geology Modeling* (August 21-27, 1994), Zdarske Vrchy, Czech Republic. pp.164-176. 1994.

Pashkovsky, I. S. Estimated recharge of underground waters and mathematical modeling of surface and underground runoff from river basins. in: *Methods of waterchange study*. Naukova Dumka, Kiev. . pp. 79-103. 1988. (in Russian)

Zeegofer, Yu. O., Klyukvin A. N., Pashkovsky I. S., Roshal A. A. *Continuously operating models of the hydrolithosphere for urban agglomerations*, M., Nauka, 1991, 196 p. (in Russian)

The results of simulation of benzene migration in unsaturated zone

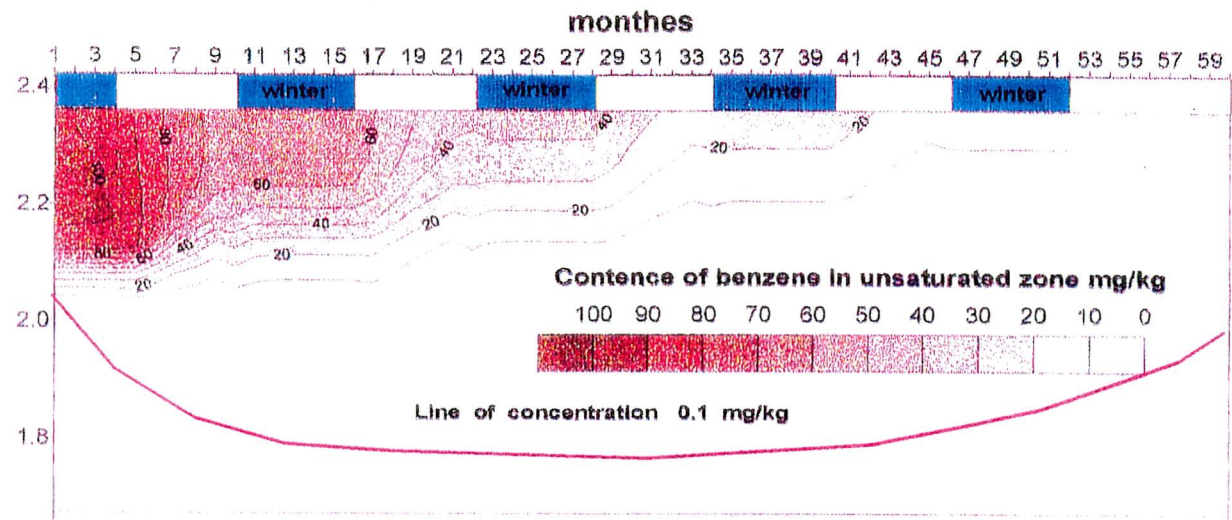

Height above the water table in m.

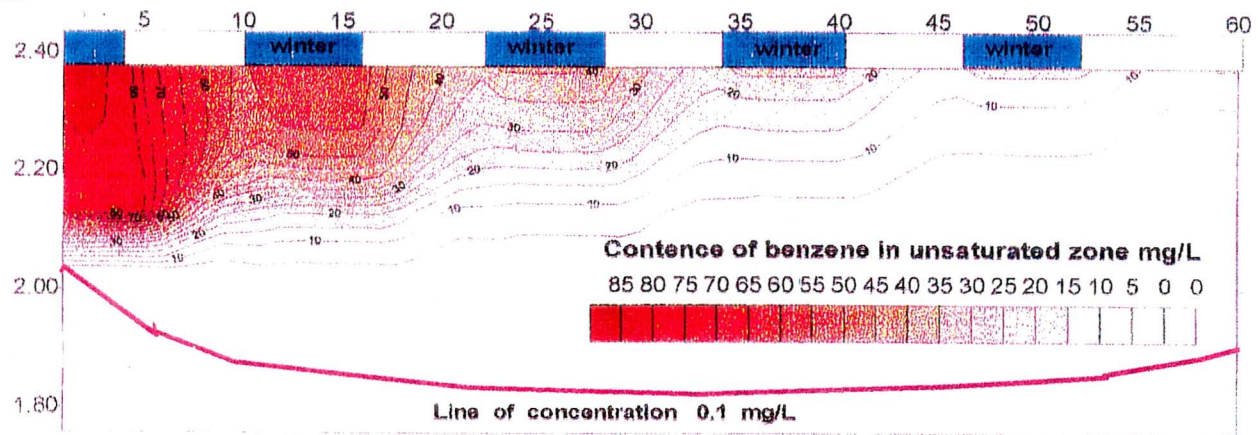



### MOISTURE CONTENT

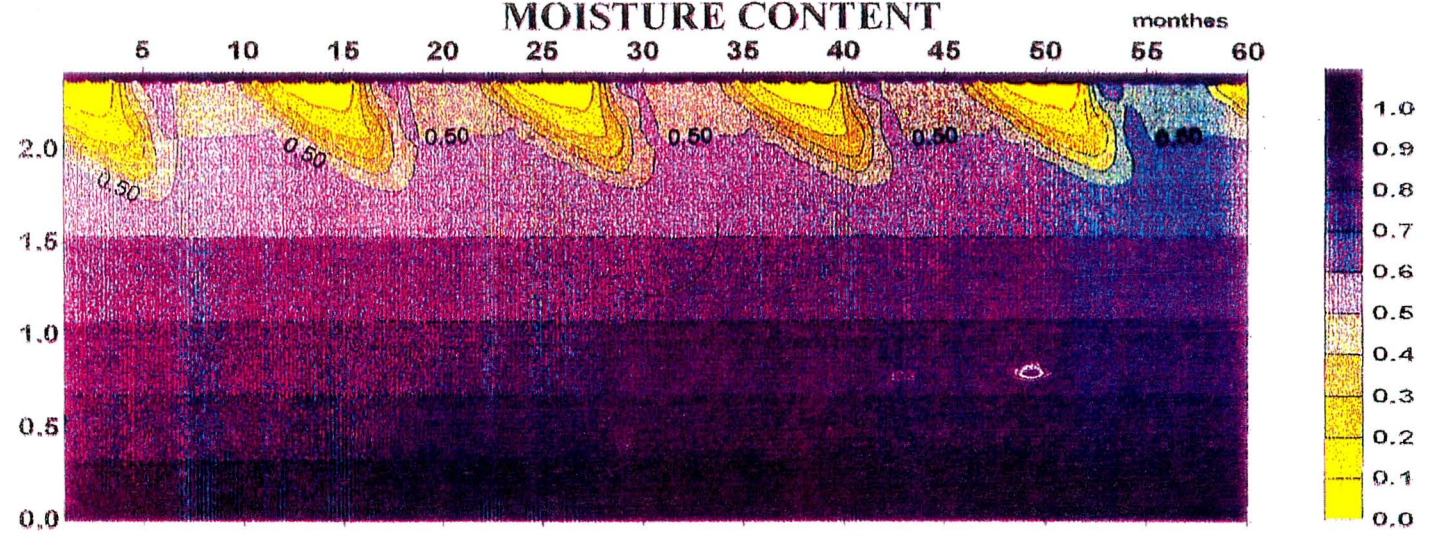

ie height  
ove the water  
ole in m.

### TEMPERATURE

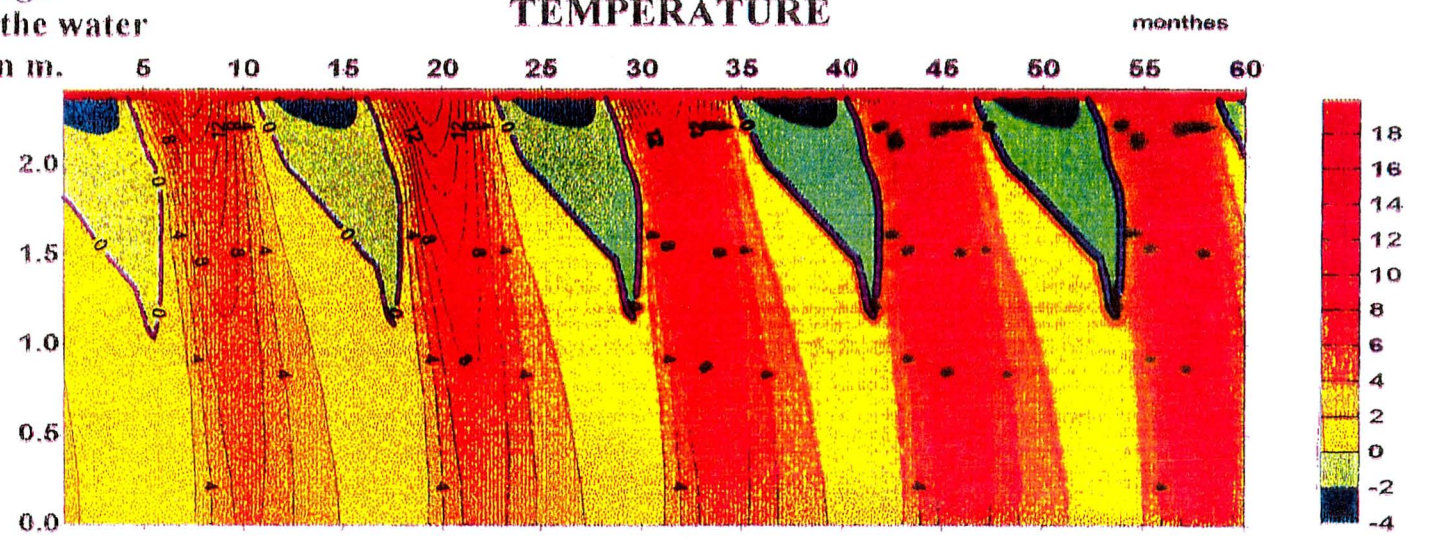

# **Non-Equilibrium Flows of Fluids in Natural Rocks**

**G.I. Barenblatt**  
Russian Academy of Sciences  
Moscow, Russia  
University of California, Berkeley

July 8 - 9, 1997

## **JOINT RUSSIAN-AMERICAN HYDROGEOLOGY SEMINAR**

Russian - American Center for Contaminants Transport Studies  
Ernest Orlando Lawrence Berkeley National Laboratory  
Berkeley, California 94720

G.I. Barenblatt

Non-Equilibrium Flows of Fluids  
in Natural Rocks

Joint Russian-American  
Hydrogeology Seminar

LBL, 8 July 1997

Participants:

Dr. A. P. Vinnichenko (Moscow)

Dr. A. A. Gilman (San Jose)

Professor J. L. Vázquez (Madrid)

Dr. A. G. Kovalov (Moscow)

Dr. V. M. Prostokishin (Moscow)

# Micromechanics of fluid flows in natural rocks

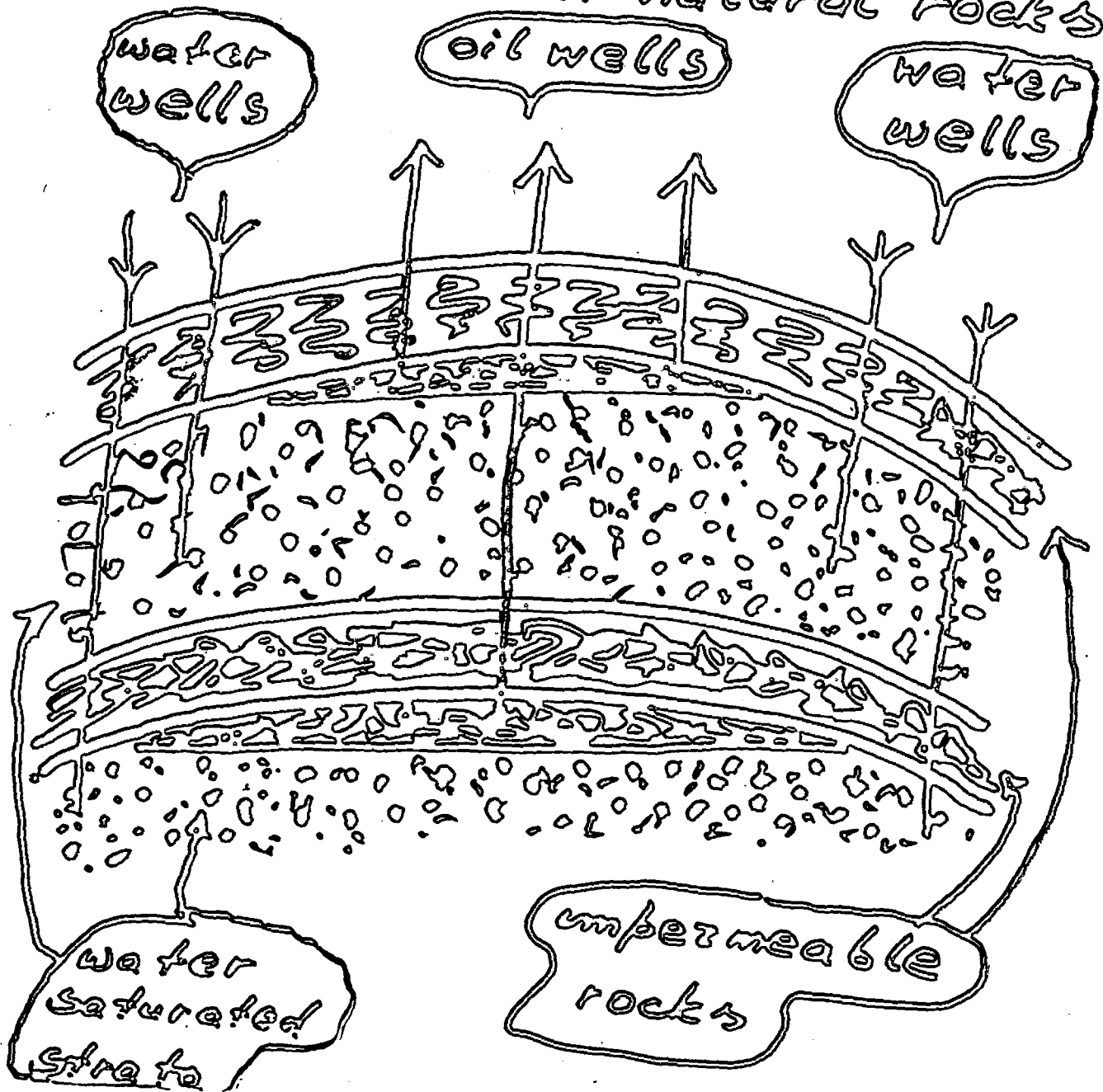

MM of fluid flow through porous media

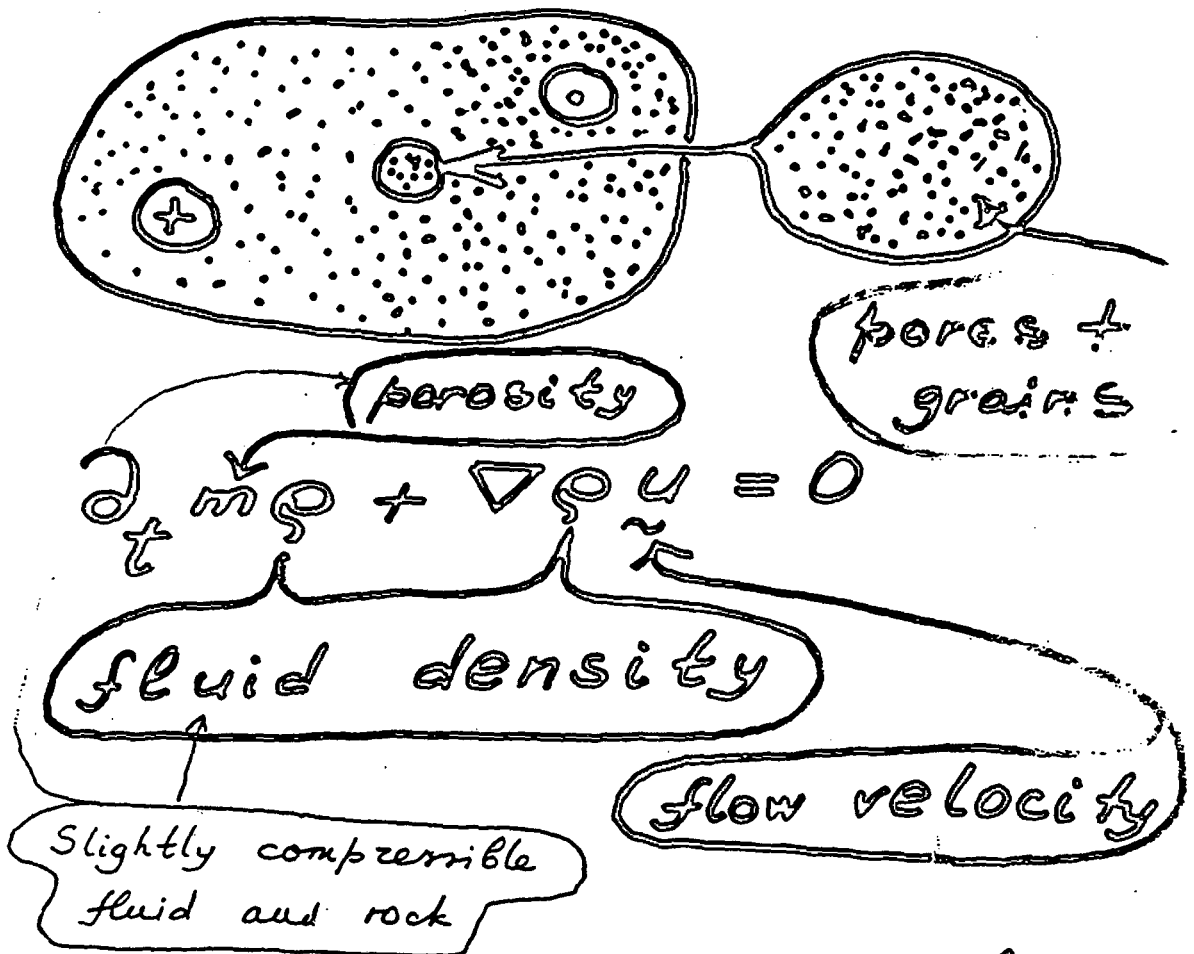

- the mass conservation law

(constitutive)

# Governing equations

"permeability"

$$\vec{u} = - \frac{k}{\mu} \nabla p$$

pressure

fluid viscosity

constants

$$dm = \beta_r dp, \quad d\rho/\rho = \beta_f dp$$

$$\partial_t p = \kappa \Delta p, \quad \kappa = \frac{k}{\mu(m\beta_r + \beta_f)}$$

!ugly facts!

$u = - \frac{k}{\mu} \nabla p$

$u = - \frac{k}{\mu} \nabla p + A \partial_t \nabla p$

1 = "pores" - cracks +  
"grains" - blocks

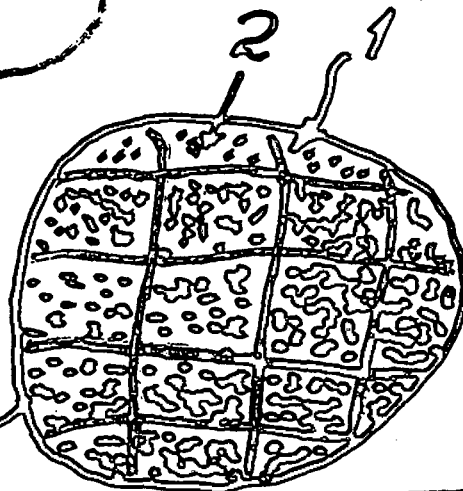
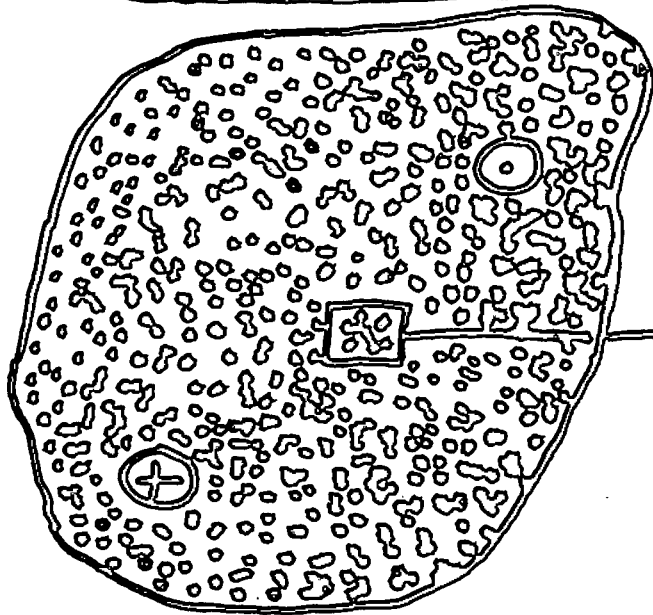

2 = pores +  
grains

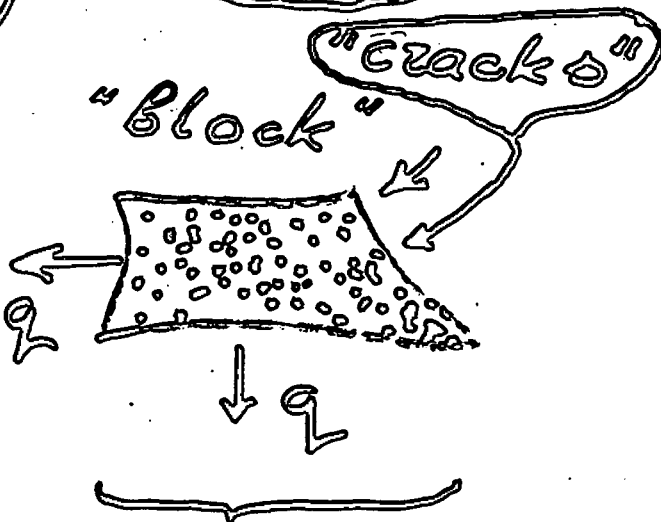

Conservation

Laws:

$$\partial_t (m_2 \rho) + \rho = 0$$

$$\nabla \cdot (\rho u_1) - \rho = 0$$

volume of cracks  
and permeability  
of blocks are  
neglected!



constitutive  
Governing Equation

$$\tilde{u}_1 = - \frac{k_1}{\mu} \nabla \beta,$$

Kinetic equation

$$q = \frac{\rho k_2 (\beta_2 - \beta_1)}{\mu \rho^2}$$

$$\frac{\partial \beta_1}{\partial t} = \kappa \Delta \beta_1 + \kappa \tau \frac{\partial}{\partial t} \Delta \beta_1 \quad \text{!}$$

$$\kappa = \frac{k_1}{\mu(\beta_{r2} + m_2 \beta_s)}, \quad \tau = \frac{e^2 \mu (\beta_{r2} + m_2 \beta_s)}{k_2}$$

$T \gg \tau$  - former case

$T \sim \tau$  - new properties

1° Support is a finite one, but, contrary to the classical case, it is finite at  $t=0$

NB: cl. case:  $\partial \sigma \propto \Delta \phi \propto \Delta x$   
 Feynman's result:

$$\sigma = \sigma\left(\frac{x}{\sqrt{t}}\right), \quad x_0 \sim \sqrt{t}$$

2° 'Stabilized zone'

at  $\tau > 0$

$$\sigma = \sigma(x - \sqrt{t})$$

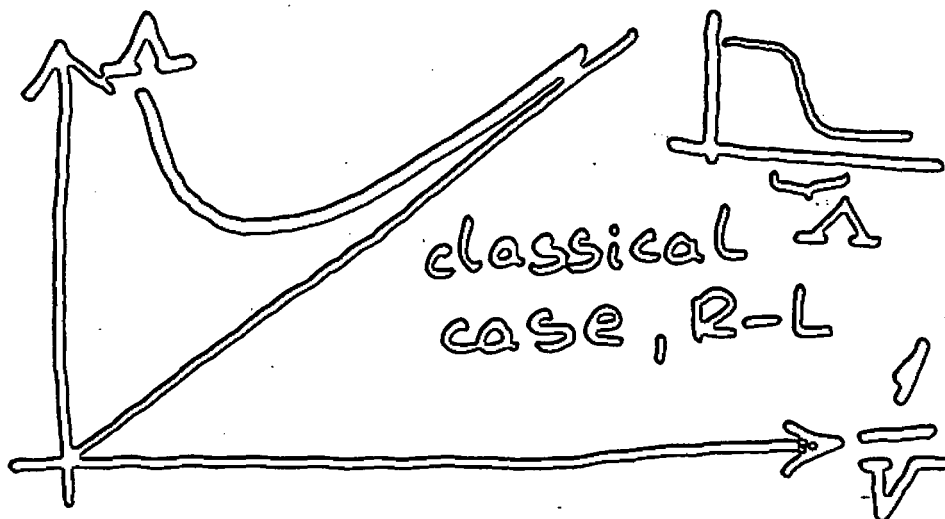

Small amount of condensate

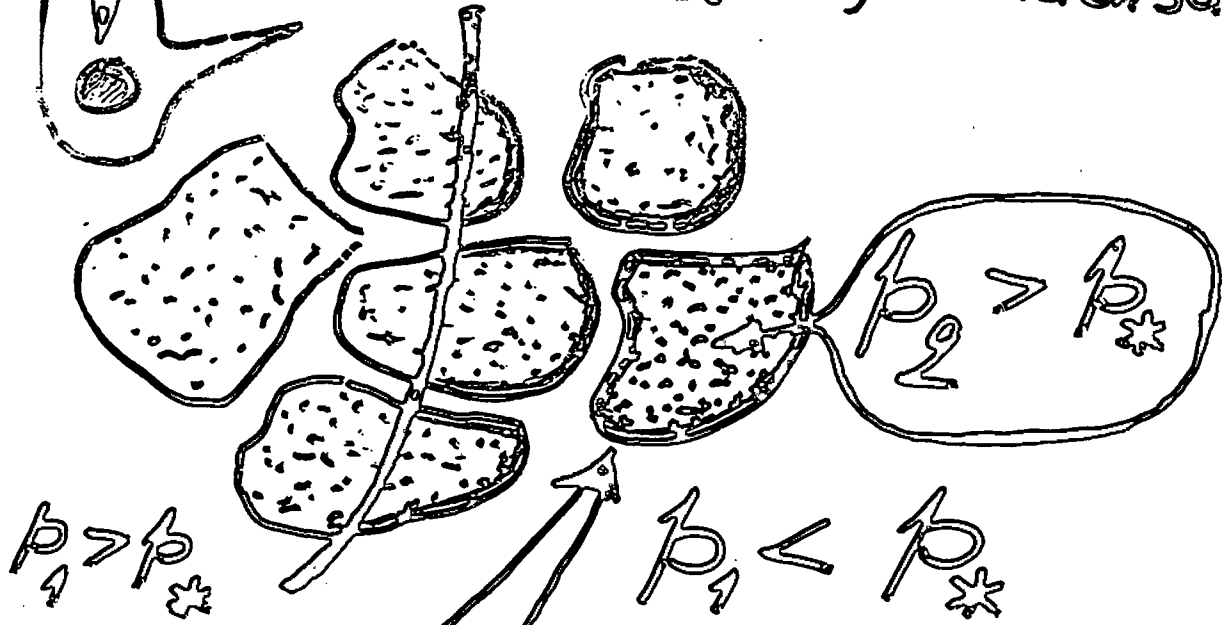

Blocks are enveloped by thin envelopes of moving condensate

NB!  $Q \sim \frac{dp}{dt} \sim (\nabla p)^2$

$Q = \frac{\rho_0 k_2}{\ell^2 \rho_0 \mu_0 g} (p_2^2 - p_*^2)$

Water  $\rightarrow$  oil displacement  
in natural strata

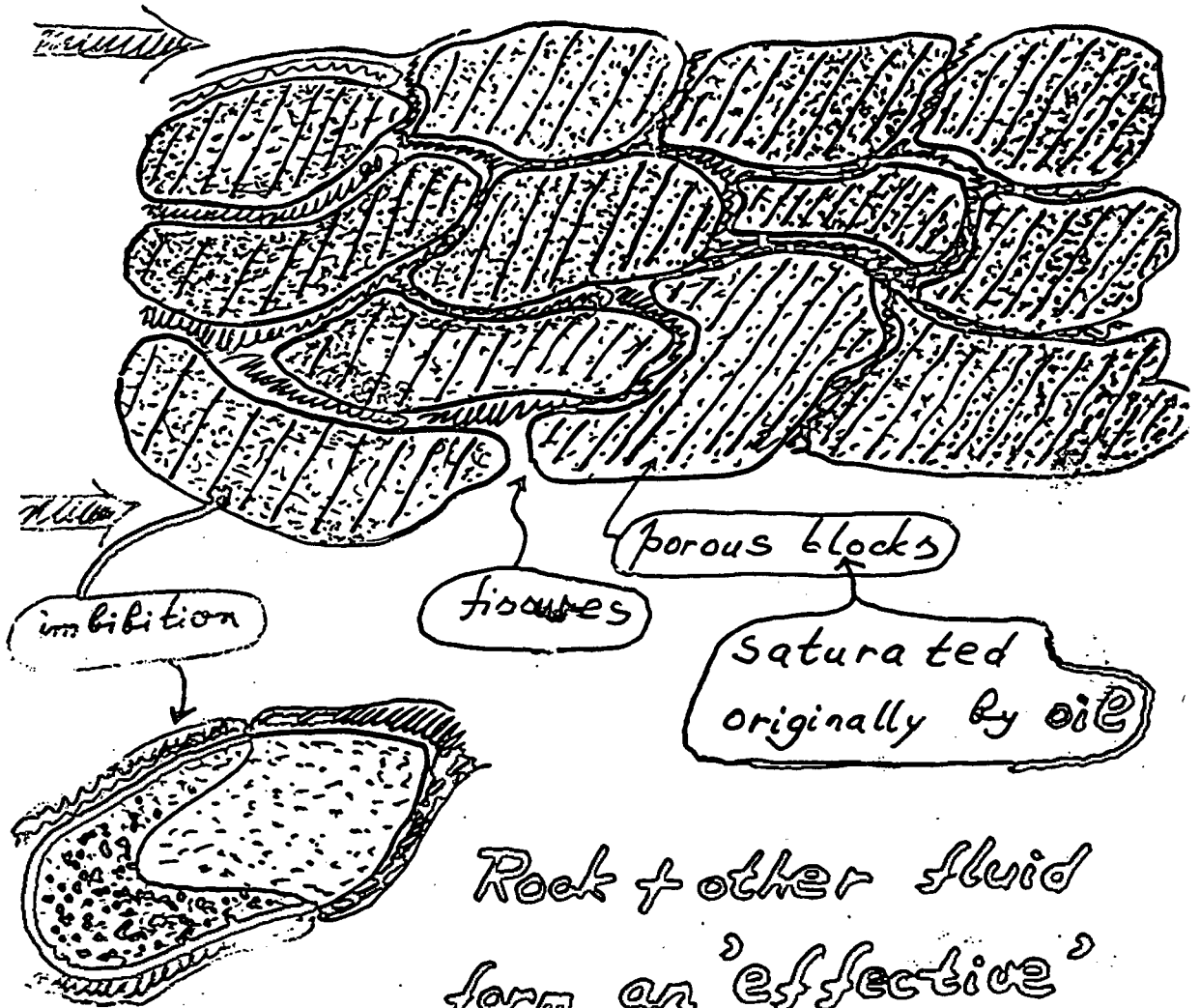

Rock + other fluid  
form an 'effective'  
porous medium for a  
given fluid

Homogeneous fluid

Darcy law

$$\vec{u} = - \frac{k}{\mu} \nabla p$$

Incompressible flow

$$\nabla \cdot \vec{u} = 0$$

$$\Delta p = 0$$

NB: non-trivial bc at free  
surfaces!



Fluid = water + oil mixture  
 (1) (2) ←

Capillary imbibition in

Blocks

W-O. front

$i = 1, 2$

$$\tilde{u}_i = - \frac{k}{\mu_i} f_i \nabla p_i$$

$$p_2 - p_1 = \gamma \cos \theta \sqrt{\frac{m}{k}} J$$

Conservation laws

$$m \frac{\partial \sigma}{\partial t} + \nabla_{\tilde{1}} u_1 = 0 \leftarrow \text{water}$$

$$m \frac{\partial (1 - \sigma)}{\partial t} + \nabla_{\tilde{2}} u_2 = 0 \leftarrow \text{oil}$$

$u_1 + u_2 = 0$  : imbibition!  
 $\tilde{u}_1 + \tilde{u}_2 = \tilde{u}_0(t)$  : displacement

Classical approach

(Muscat, here)

i Local equilibrium  $\rightarrow$   
 $f_1, f_2, J$  are universal

functions of the local

water saturation  $\sigma$

$f_1(\sigma), f_2(\sigma), J(\sigma)$ :

This makes the system

a closed one.

i universal - can be measured  
in a steady flow!

Steady flow:

$f_1, f_2, J$ :  $\sigma$ -water saturation

$$0 < \sigma < 1$$

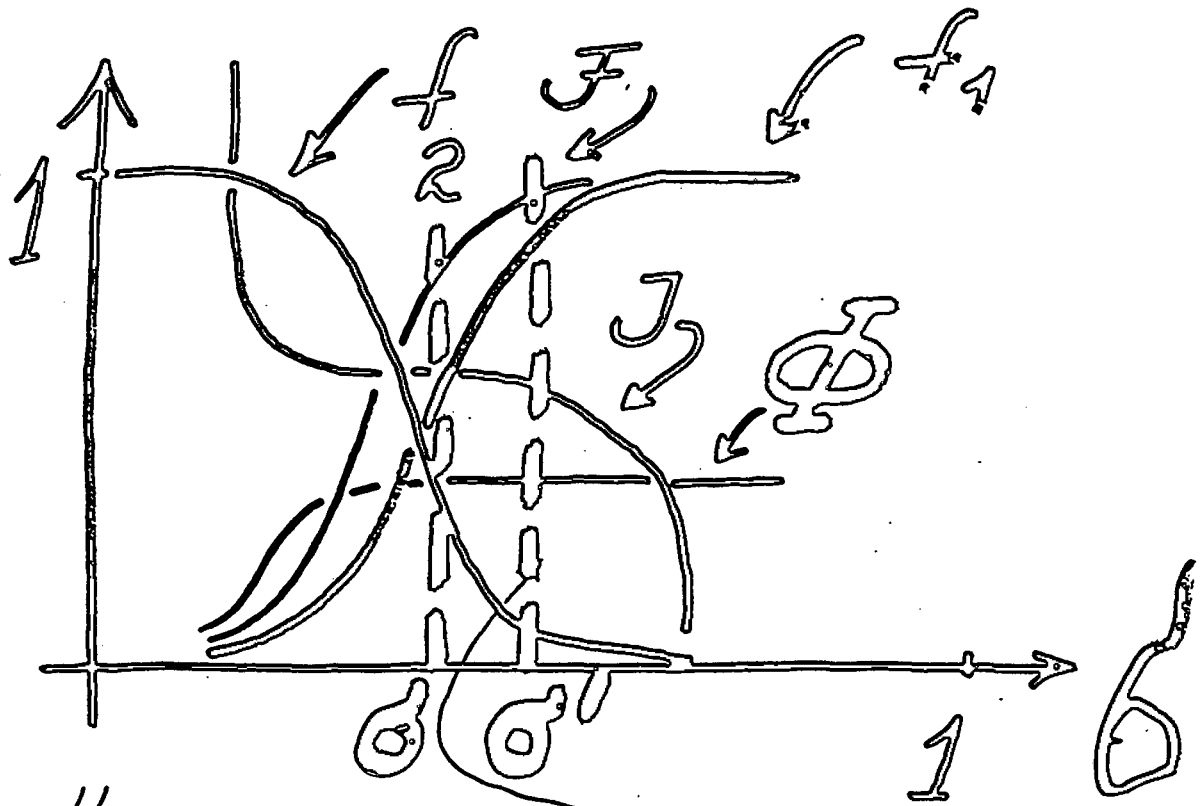

However:

Flow is unsteady!

But - we are lucky: the form of curves is very instructive



In particular: ID case

$$u_1 = -\frac{k_1}{\mu_1} \int \partial_x \rho_1, \quad u_2 = -\frac{k_2}{\mu_2} \int \partial_x \rho_2$$

$$\rho_2 - \rho_1 = \gamma \cos \Theta \sqrt{\frac{m}{k_2}} J$$

$$m \partial_t \sigma + \partial_x u_1 = 0, \quad -m \partial_t \sigma + \partial_x u_2 = 0$$

$$\partial_t \sigma + \frac{u_0}{m} \partial_x \mathcal{F}(\sigma) =$$

$$= a \Delta \Phi(\sigma) \quad \text{!}$$

$$\mathcal{F} = \frac{f_1(\sigma)}{f_1(\sigma) + \frac{\mu_1}{\mu_2} f_2(\sigma)}$$

degen.  
finite support

$$\Phi = - \int_0^\sigma \mathcal{F}(\sigma) f_2(\sigma) J'(\sigma) d\sigma$$

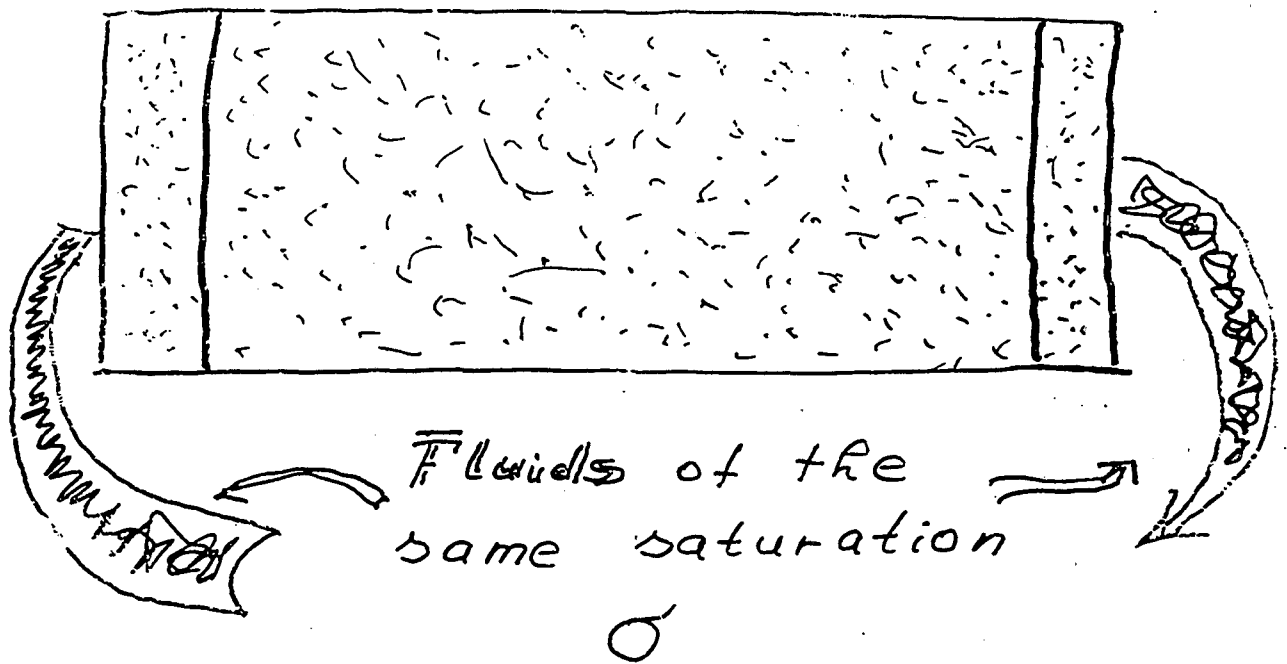

5-6 pore volumes should pass through the sample before measurement is to be started

! Both in displacement and imbibition the flows are substantially unsteady  
Non-equilibrium!

## Generalized Darcy law

$$\vec{u}_1 = -\frac{k}{\mu_1} f_1(\sigma') \nabla p_1$$

$B, B \neq APV$

$$\vec{u}_2 = -\frac{k}{\mu_2} f_2(\sigma') \nabla p_2$$

$$p_2 - p_1 = \frac{\gamma \cos \theta}{(k/m)^{1/2}} J(\sigma')$$

The only assumption is that  $\sigma'$  is the same for all three fns!

$$\sigma' - \sigma = ?$$

At  $t \ll \tau$  there is no universality. Fine details of the structure of p.m. and initial water distribution play the role

At  $t \sim \tau$  the IA regime begins. Universality

$$\sigma' - \sigma = \Phi(\tau \partial_t \sigma)$$

$$\frac{d\sigma}{dt} \sim \frac{1}{T}, \quad \tau \ll T$$

$$\sigma' - \sigma = \tau \partial_t \sigma$$

$$\tau(\sigma)?$$

iBasic relationships!

$$m \partial_t \sigma + \nabla_{\sim 1} u_1 = 0$$

Classical theory,  
Luceat, 1937  
 $\sigma' = \sigma$

$$m \partial_t (1 - \sigma) + \nabla_{\sim 2} u_2 = 0$$

$$u_1 \sim - \frac{\hbar}{m} f_1(\sigma') \nabla p_1, \quad u_2 \sim - \frac{\hbar}{m} f_2(\sigma') \nabla p_2$$

$$p_2 - p_1 = \frac{\gamma \cos \theta}{(\hbar/m)^{1/2}} J(\sigma')$$

$f_n$ s determined from ssexper.

# A. Capillary imbibition

GIB & AAC

$$u_1 + u_2 = 0$$

$$m \frac{\partial \sigma}{\partial t} = \frac{\gamma \cos \theta}{\mu_2} \left( \frac{t}{m} \right)^{1/2} \Delta \Phi(\sigma')$$

$$\Phi = - \int_0^\sigma \frac{f_1(\sigma) f_2(\sigma) J'(\sigma) d\sigma}{f_1(\sigma) + \frac{\mu_1}{\mu_2} f_2(\sigma)}$$

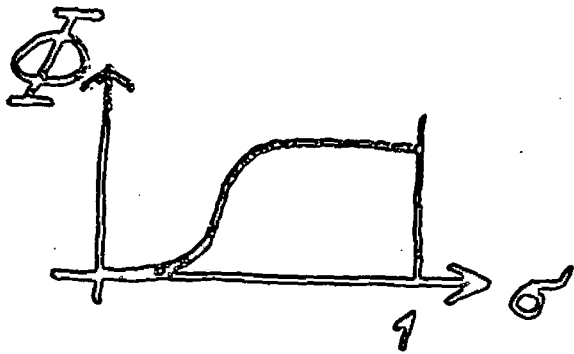

NL PDE!

Slow imbibition,  $t \sim T$

$\sigma' = \sigma$

Ryzhik Eqn

$$\frac{\partial \sigma}{\partial t} = \frac{\gamma \cos \theta}{\mu_2} \left( \frac{t}{m} \right)^{1/2} \Delta \Phi(\sigma)$$

# Non-equilibrium IA

$$\frac{d}{dt} \sigma = \frac{\gamma \cos \theta}{\mu_2} \left( \frac{k}{m} \right)^{1/2} \Delta \Phi(\sigma')$$

$$\frac{\sigma' - \sigma}{\tau} = \partial_t \sigma$$



$$\frac{d}{dt} \sigma' = a \Delta \Phi(\sigma') + a\tau \partial_t \Delta \Phi(\sigma')$$

IC? They are given for  $\sigma$ !

$$\sigma' - \sigma = a\tau \Delta \Phi(\sigma')$$

$$\sigma'_0 - a\tau \Delta \Phi(\sigma'_0) = \sigma_0(x)$$

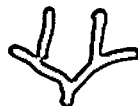

Eqn for IC.

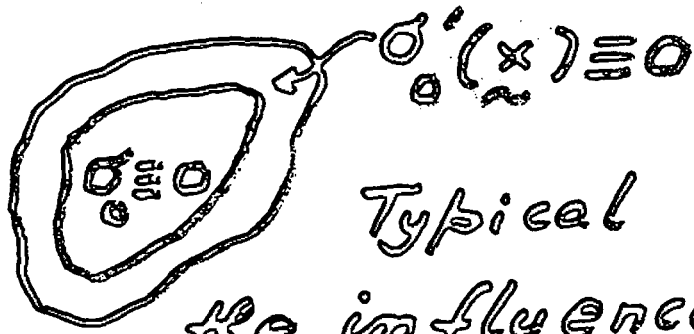

Typical IA effect:  
the influence of details  
disappears

Example:

Semi-infinite porous block

$$0 \leq x < \infty$$

$$\sigma_0(x) \equiv 0,$$

$$\text{at } \frac{d^2 \phi(\sigma'_0)}{dx^2} - \sigma'_0 = 0, \quad \sigma'_0(0) = 1$$

$$\sigma'_0(\infty) = 0$$

$$\sigma'_0(x_0) = 0$$

$$\left. \frac{d\phi(\sigma'_0)}{dx} \right|_{x=x_0} = 0$$

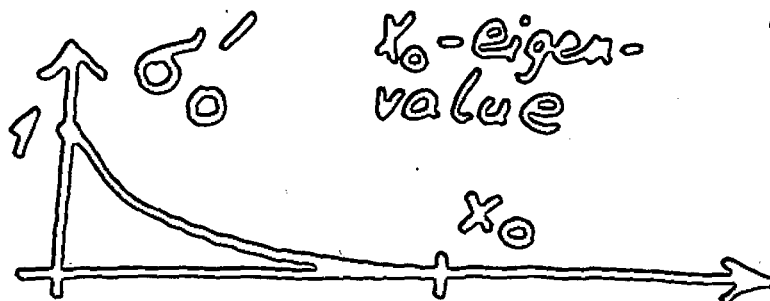



AB :

$$\sigma' - \sigma + \varepsilon \partial_t^2 \sigma' = \varepsilon \Delta \Phi(\sigma')$$

IC for  $\sigma'$ . Time is fast:

$$t_{\text{fast}} = \frac{t}{\varepsilon}$$

At

$$t_{\text{fast}} \rightarrow \infty, \text{ but } t < \tau$$

$\sigma'$  tends to a solution

to a steady problem:

$$\varepsilon \partial_t^2 \sigma' \rightarrow 0$$

$Q(t)$  - amount of released oil

$\Xi$  amount of absorbed water

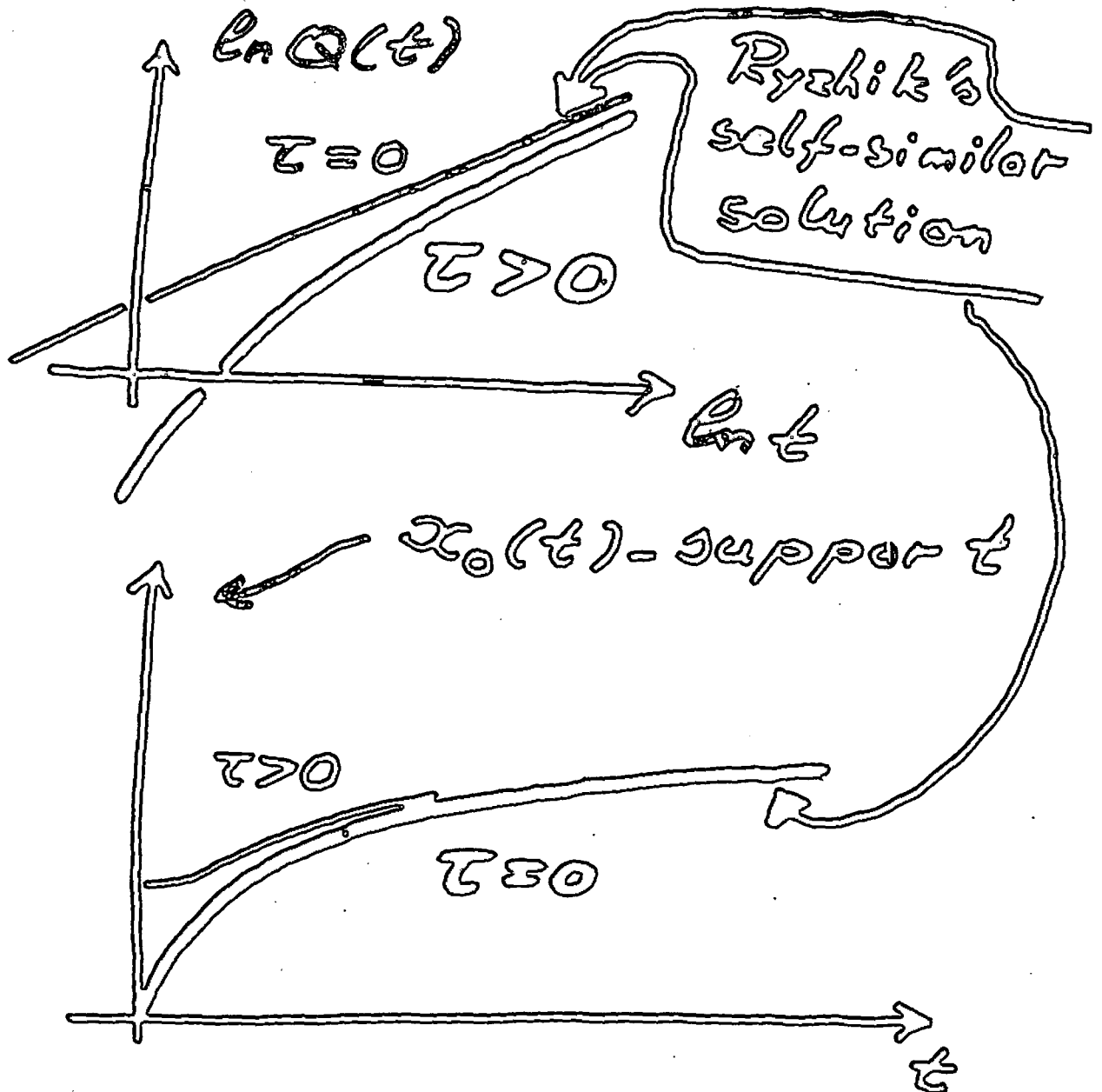

! FORCED !  
 B. Water-oil displacement

$$\underline{u} = \underline{u}_1 + \underline{u}_2 \neq 0, \quad \nabla \underline{u} = 0$$

$$\frac{d}{dt} \sigma + \frac{\underline{u}}{m} \nabla \mathcal{F}(\sigma') = a \Delta \Phi(\sigma')$$

$$\frac{d}{dt} \sigma' + \frac{\underline{u}}{m} \nabla [\mathcal{F}(\sigma') + \tau \frac{\partial}{\partial t} \mathcal{F}(\sigma')]:$$

$$= a \Delta [\Phi(\sigma') + \tau \frac{\partial}{\partial t} \Phi(\sigma')]$$

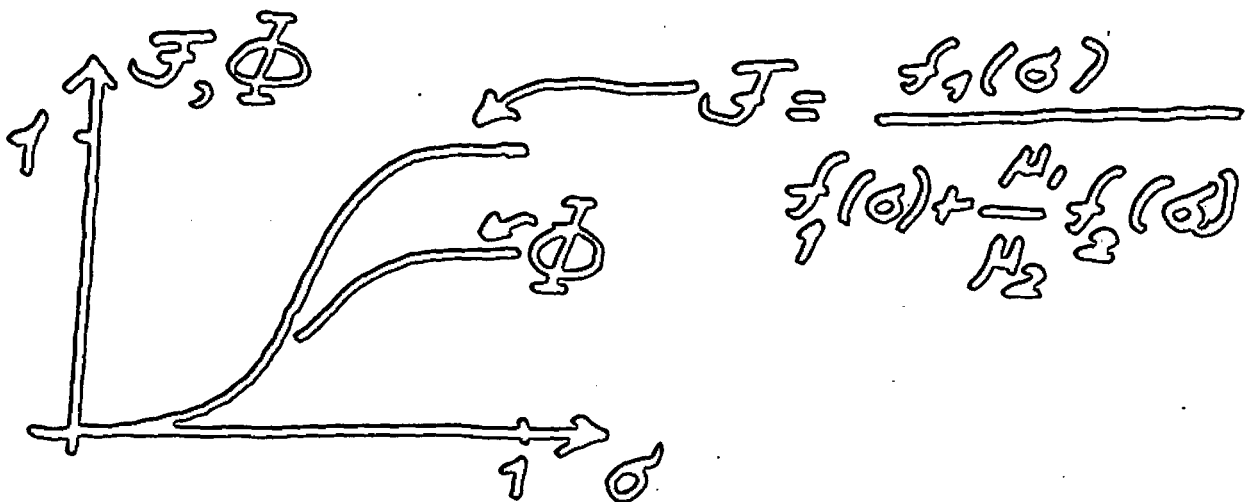

Averaging ('homogenization')

Water saturation

$\sigma$

part of the porous volume  
occupied by water

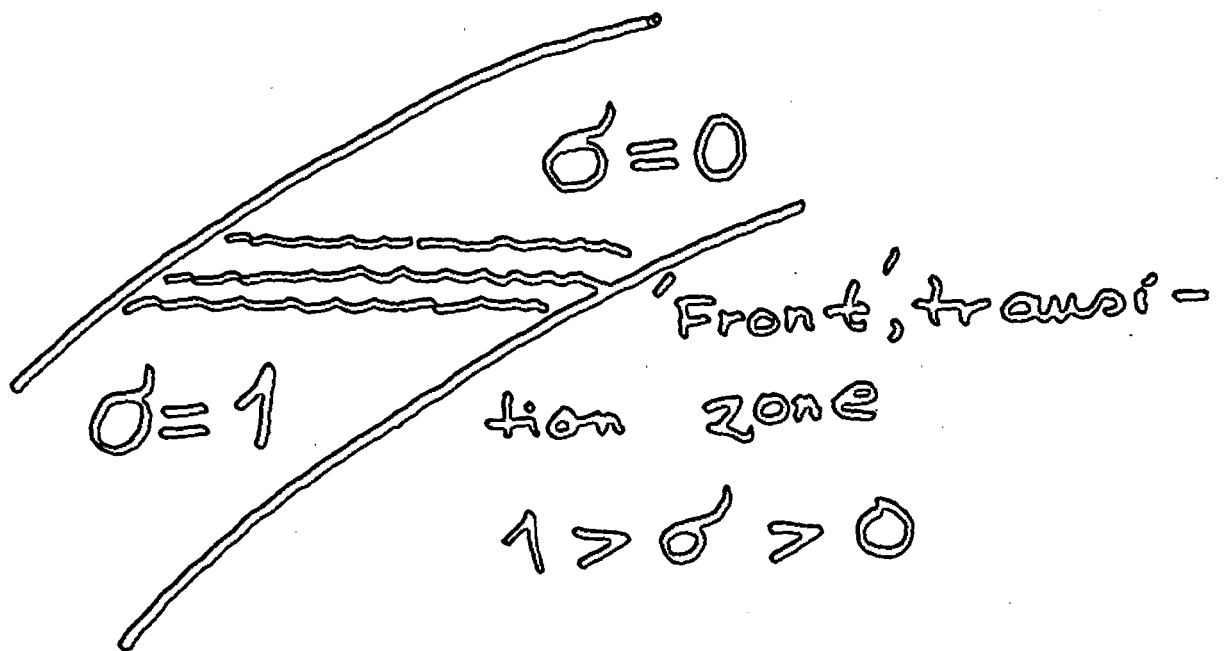

# Water-oil displacement

$$m \frac{\partial \sigma}{\partial t} + \nabla \cdot \underline{u}_1 = 0 \quad - \quad m \frac{\partial \sigma}{\partial t} + \nabla \cdot \underline{u}_2 = 0$$

$$\underline{u}_1 = -k \frac{f_1(\sigma')}{\mu_1} \nabla p_1$$

$$\underline{u}_2 = -k \frac{f_2(\sigma')}{\mu_2} \nabla p_2$$

$$p_2 - p_1 = \frac{\tau \cos \theta}{(k/m)^{1/2}} J(\sigma')$$

$$\sigma' = \sigma + \tau \frac{\partial \sigma}{\partial t}$$

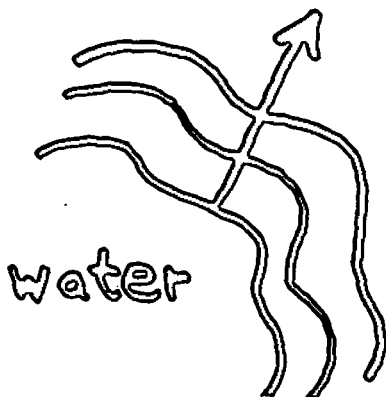

oil

1D case

The reason of this delay is very instructive: in the equilibrium flows <sup>the</sup> water flows in narrow 'channels' the oil flows in wide channels.

When water saturation increases, the flow needs some characteristic time  $\tau$  for the redistribution of the channels between the fluids

Buckley-Leverett:  
external solution

$$m \frac{\partial \sigma}{\partial t} + V \frac{\partial F(\sigma)}{\partial x} = 0$$

$$u_1 + u_2 = u_0(x); V = \text{const}$$

Internal solution for  $\tau=0$ :

$$m \frac{\partial \sigma}{\partial t} + \frac{\partial}{\partial x} [V F(\sigma) + \mu \frac{f_2(\sigma)}{2} F(\sigma) \frac{\partial J(\sigma)}{\partial x}] = 0$$

"Stabilized zone"

$$\sigma = \sigma(x - Vt)$$

Thickness of S.Z.

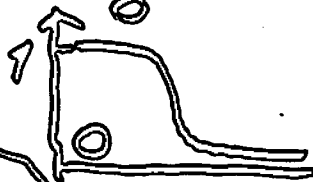

Rappoport and Leas, 1953

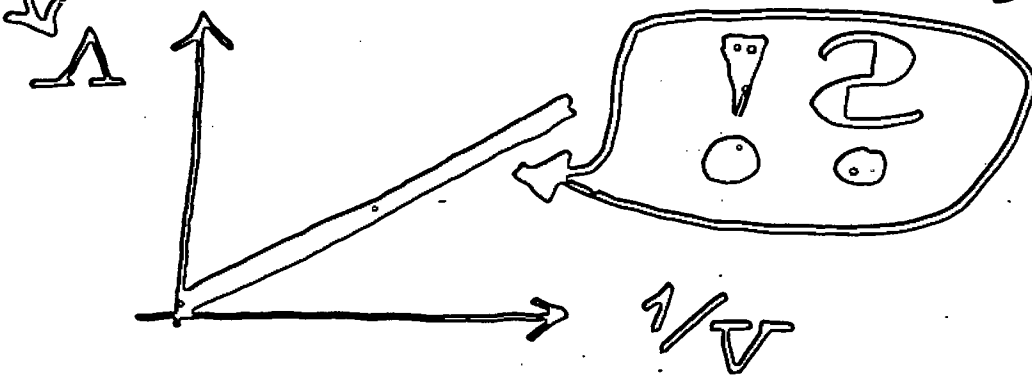

Internal solution for  $\tau > 0$

$$m \frac{\partial \sigma}{\partial t} + \frac{\partial}{\partial x} [u_0 \mathcal{F}(\sigma')] + \mu f_2(\sigma) \mathcal{F}(\sigma') (\sigma') = 0$$

$$\sigma' - \sigma = \tau \frac{\partial \sigma}{\partial t}$$

General case: Eqn for  $\sigma'$

$$m \frac{\partial \sigma'}{\partial t} + \mu \nabla [\mathcal{F}(\sigma) + \tau \frac{\partial \mathcal{F}(\sigma')}{\partial t}] =$$

solen

$$= \kappa \Delta [\Phi(\sigma') + \tau \frac{\partial \Phi(\sigma')}{\partial t}]$$

Initial condition?

It is given for  $\sigma$ , not  $\sigma'$ !



Initial condition:

$$m \sigma'_0(x) + \tau u(x, 0) \nabla \mathcal{F}(\sigma'_0(x)) -$$

$$- m a \tau \Delta \Phi(\sigma'_0(x)) = m \sigma_0(x)$$

  
 a given function

BC:

$$\sigma'_0|_{\partial\Omega} = \sigma_0(x)|_{\partial\Omega} + \tau \left( \frac{\partial \sigma}{\partial t} \right)_{\partial\Omega, t=0}$$

In particular, for  
1D problem the eqn

takes the form

$$m \partial_t \sigma' + v_0 \partial_x [\mathcal{F}(\sigma') + \tau \partial_x \mathcal{F}(\sigma')] =$$

$$= a n \partial_{xx} [\Phi(\sigma') + \tau \partial_x \Phi(\sigma')]$$

Special case:  
 capillary effects are  
 negligible:

$$m \frac{d}{dt} \left[ \sigma' + u(t) \right] \frac{d}{dx} \left[ F(\sigma') + \tau \frac{dF(\sigma')}{dx} \right] = 0$$

The equation for the  
 initial condition (ODE!)

$$\frac{\tau u_0(0)}{m} \frac{d}{dx} \left[ F(\sigma'_0) + \sigma'_0(x) \right] = \sigma'_0(x)$$

If  $\sigma_0(x) \equiv 0$ ,

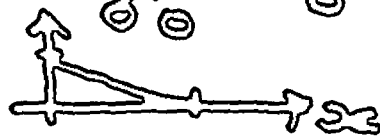

$$x - \frac{\tau u_0(0)}{m} \int_{\sigma'_0}^1 \frac{F'(\xi) d\xi}{\xi} = 0$$

1° Support is a finite one, but, contrary to the classical case, it is finite at  $t = 0$

NB: cl. case:  $\partial \sigma \propto \Delta \Phi \propto \Delta x$   
 Rydberg's rule:  $t$   
 $\sigma = \sigma\left(\frac{x}{\sqrt{t}}\right), x_0 \sim \sqrt{t}$

2° 'Stabilized zone' at  $\tau > 0$   $\sigma = \sigma(x - \sqrt{t})$

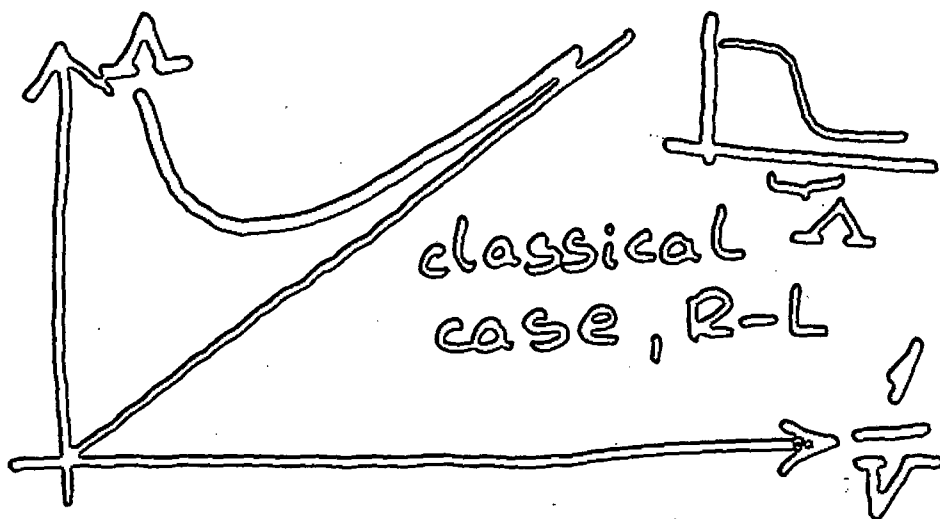

# Solid phase precipitation (A.G. Kovalev)

Simple model

$$\Delta \sigma = \Phi(p, T)$$

$$\Phi(p_0, T_0) = 0$$

$$\Delta \sigma = Q_p (p - p_0) + Q_T (T - T_0)$$

In principle, these coefficients can have various signs !

Small (even submicron) particles of solid phase attract the components of oil having high molecular weight. New high viscosity component of oil is formed.

Here simplest case is considered: water  
 in this lecture  
 saturation is equal to zero. General case  
 is also considered.

$\sigma$ -saturation by 'high-viscosity' com-  
 ponent,  $\mu_h$  - its viscosity

$$\vec{u}_1 = -\frac{k}{\mu} f_1(\sigma) \nabla p, \quad \vec{u}_2 = -\frac{k}{\mu_h} f_2(\sigma) \nabla p$$

we ignore capillary effects between  
 two components of oil:

$$p_2 - p_1 = 0, \quad f_1 = 1 - \sigma, \quad f_2 = \sigma$$

$$\frac{\partial}{\partial t} m(1 - \sigma) + \nabla \cdot \vec{u}_1 = -Q$$

$$\frac{\partial}{\partial t} m\sigma + \nabla \cdot \vec{u}_2 = Q$$

$$Q = A m(1 - \sigma) \Phi(p, T), \quad A = \text{Const}$$

# Numerical experiments

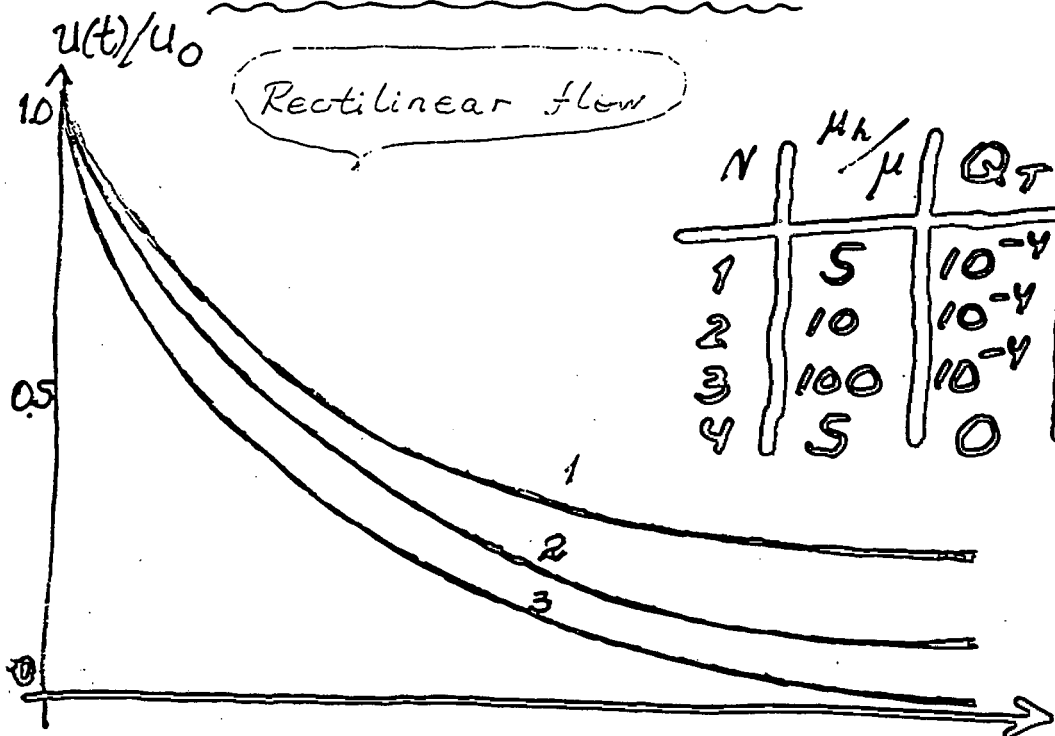

$N$	$\mu_h/\mu$	$Q_T$	$Q_B$
1	5	$10^{-4}$	0
2	10	$10^{-4}$	0
3	100	$10^{-4}$	0
4	5	0	$10^{-9}$

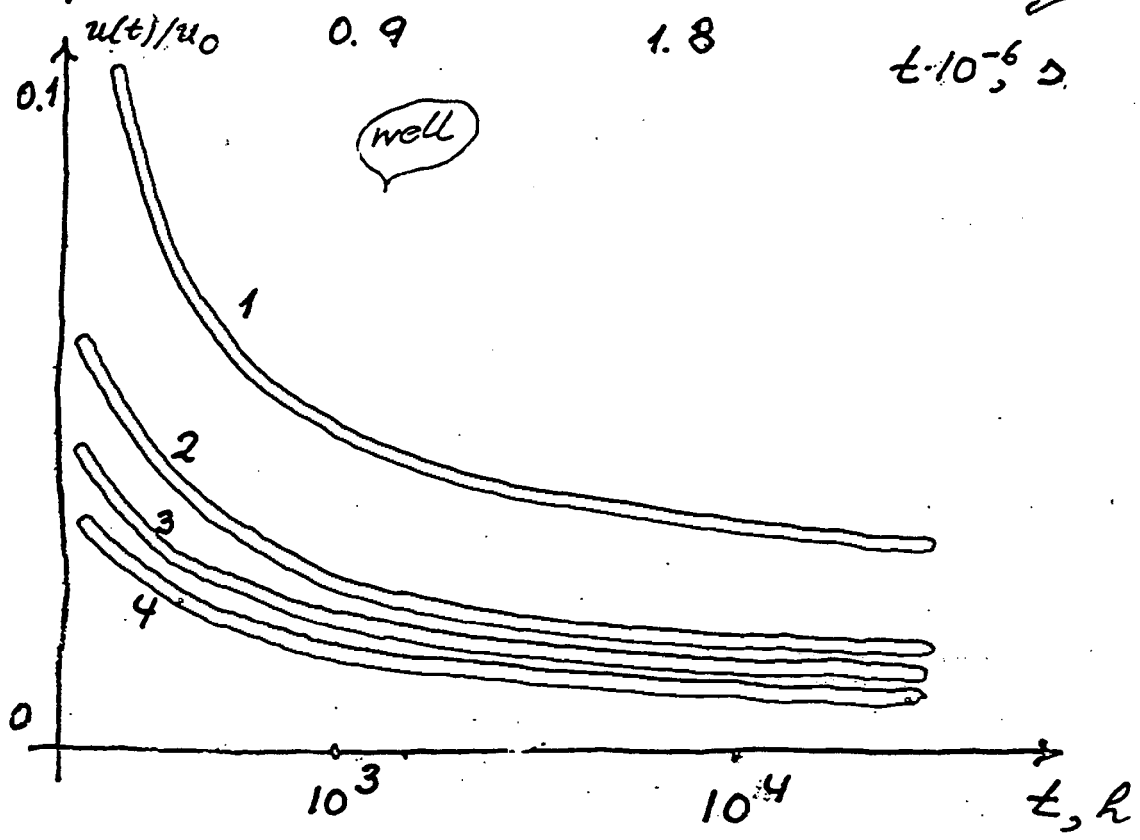

Heat balance equation

$$\frac{\partial}{\partial t} (\rho T + \rho m i) + \nabla \cdot (\rho i \underline{u}) = \nabla \cdot (\lambda \nabla T)$$

NB: Zhetysbai

$$\underline{u} = \underline{u}_1 + \underline{u}_2,$$

$$di = c_p dT, \text{ high}$$

low?

$$\nabla \underline{u} = 0$$

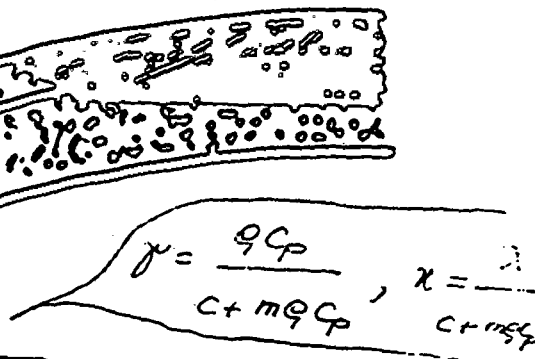

$$\frac{\partial T}{\partial t} + \gamma \underline{u} \cdot (\nabla T) = \chi \nabla^2 T$$

$$\nabla \beta = - \frac{\underline{u}}{\frac{\mu}{\mu_R} \left( \frac{\mu_R}{\mu} f_1(\sigma) + f_2(\sigma) \right)}$$

$$\frac{\partial m \sigma}{\partial t} + \underline{u} \cdot \nabla F(\sigma) = A m (1 - \sigma) \Phi(\beta, T)$$

$$F(\sigma) = \frac{f_2(\sigma)}{\frac{\mu_R}{\mu} f_1(\sigma) + f_2(\sigma)}$$

# **Isolation of Radioactive Wastes in Permafrost Rock**

**Grant S. A.**  
Geochemical Sciences Division  
US Army Cold Regions Research & Engineering Laboratory

July 8 - 9, 1997

## **JOINT RUSSIAN-AMERICAN HYDROGEOLOGY SEMINAR**

Russian - American Center for Contaminants Transport Studies  
Ernest Orlando Lawrence Berkeley National Laboratory  
Berkeley, California 94720



# Isolation of Radioactive Wastes in Permafrost Rock

**Steven A. Grant**

Geochemical Sciences Division  
U.S. Army Cold Regions Research & Engineering Laboratory  
Hanover, New Hampshire

A.N. Kazakov, N.F. Lobanov  
All Russian Research and Design Institute of Production Engineering  
Ministry of Atomic Energy  
Moscow

M.V. Mironenko, and A.I. Shapkin  
Vernadsky Institute of Geochemistry and Analytical Chemistry Russian  
Academy of Sciences  
Moscow

The All Russian Research and Design Institute of Production Engineering (VNIPIPromtehnologii Institute) of the Ministry of Atomic Energy (MINATOM) of the Russian Federation is studying burial in permafrost rock on the Novaya Zemlya archipelago as a radioactive-waste isolation technology. In principle, this is a potential topic for research collaboration between U.S. Army Cold Regions Research & Engineering Laboratory (CRREL) and VNIPIPromtehnologii Institute. Due to limited funding for this topic, no substantive collaboration has occurred.

Frozen water-saturated porous media have extremely low permeabilities and great mechanical strengths. Due to these properties, artificially frozen ground has long been used to reduce seepage into and stabilize walls of soil excavations. These properties have been exploited more recently for isolating contaminated soils with barriers formed from artificially frozen ground. Since rock is generally stronger and less permeable than soil, it is natural to consider permafrost rocks as waste isolation media. Since the permafrost depths in Novaya Zemlya are great (over 200 m), if energy fluxes from the individual radioactive waste containers are not too large, it is likely that permafrost would be able to isolate the waste thermally as well as mechanically and hydrologically.

VNIPIPromtehnologii Institute has tentatively developed three designs for radioactive waste isolation: a) capped trenches for short-lived low-level radioactive solid waste, b) permafrost tunnels for short-lived intermediate-level radioactive waste, and c) deep shafts to store short-lived and long-lived high-level radioactive wastes. In principle, the advantages of this radioactive-waste isolation approach are: a) permafrost is impermeable and mechanically strong, b) Novaya Zemlya is not far from two likely sources of radioactive wastes, Murmansk and Severodvinsk, c) much of the appropriately trained staff and equipment are on site, and d) there is general acceptance by Russian environmental stakeholders. Some potential disadvantages can also be identified: a) because Novaya Zemlya is an archipelago off the Russian coast, isolating radioactive waste there may strain relations between Russia and adjoining countries, b) for long isolation times, the suitability of the site will be affected by global climate changes, which may affect permafrost depths at the site, and c) because burial in permafrost is a novel solution for the problem of isolating radioactive wastes, there will be limited benefit from lessons learned at more conventional sites (e.g., Yucca Mountain).

CRREL has hosted Dr. M.V. Mironenko of the Vernadsky Institute of Geochemistry and Analytical Chemistry, Russian Academy of Sciences, who is studying three geochemical aspects of radioactive waste isolation in permafrost: a) speciation and phase equilibria of actinides in the permafrost rock should there be a leak, b) thermophysical modeling of electrolyte solution densities at subzero temperatures, and c) corrosivity of the solutions surrounding the radioactive waste containers.

Acknowledgments: We acknowledge the support from U.S. Army Materiel Command (WK2Q6C-7411-EN09); U.S. Army Cold Regions Research & Engineering Laboratory (Work Unit AT24-SC-F02); U.S. Army Environmental Quality Basic Research Enhancement Program; Russian Foundation for Basic Research (Project number 97-05-64197); Radioactive Waste Management Grants Program, Office of International Affairs, National Research Council.

# Isolation of Radioactive Wastes in Permafrost Rock

**Steven A. Grant**

**Geochemical Sciences Division**

**U.S. Army Cold Regions Research & Engineering Laboratory**

**Hanover, New Hampshire**

**A.N. Kazakov, N.F. Lobanov**

**All Russian Research and Design Institute of Production Engineering**

**Ministry of Atomic Energy**

**Moscow**

**M.V. Mironenko, and A.I. Shapkin**

**Vernadsky Institute of Geochemistry and Analytical Chemistry Russian Academy of Sciences**

**Moscow**

Corps of Engineers  
Transatlantic Division  
Fissile Material Storage Facility, Mayak

# U.S. Army Cold Regions Research & Engineering Laboratory

**Mission**

**Budget**

# Cold Regions Environmental Quality

# U.S. Army Cold Regions Research & Engineering Laboratory

- Transarctic Transport of Radioactive Waste
- Remote Sensing of Komi Oil Spill
- Military EQ in Belarus and Russia

# Storage of Radioactive Waste in Permafrost Rock

- In principle an area of mutual interest between VNIPIPromtehnologii Institute of MINATOM and CRREL
- Nothing has been formalized due to limited Federal funding



# Properties of Frozen Ground

Liquid Water Content

Permeability

Mechanical Strength

# Energy Flows at Proposed Permafrost Radioactive Waste Isolation Site

Average Annual Temperature Below 0 °C

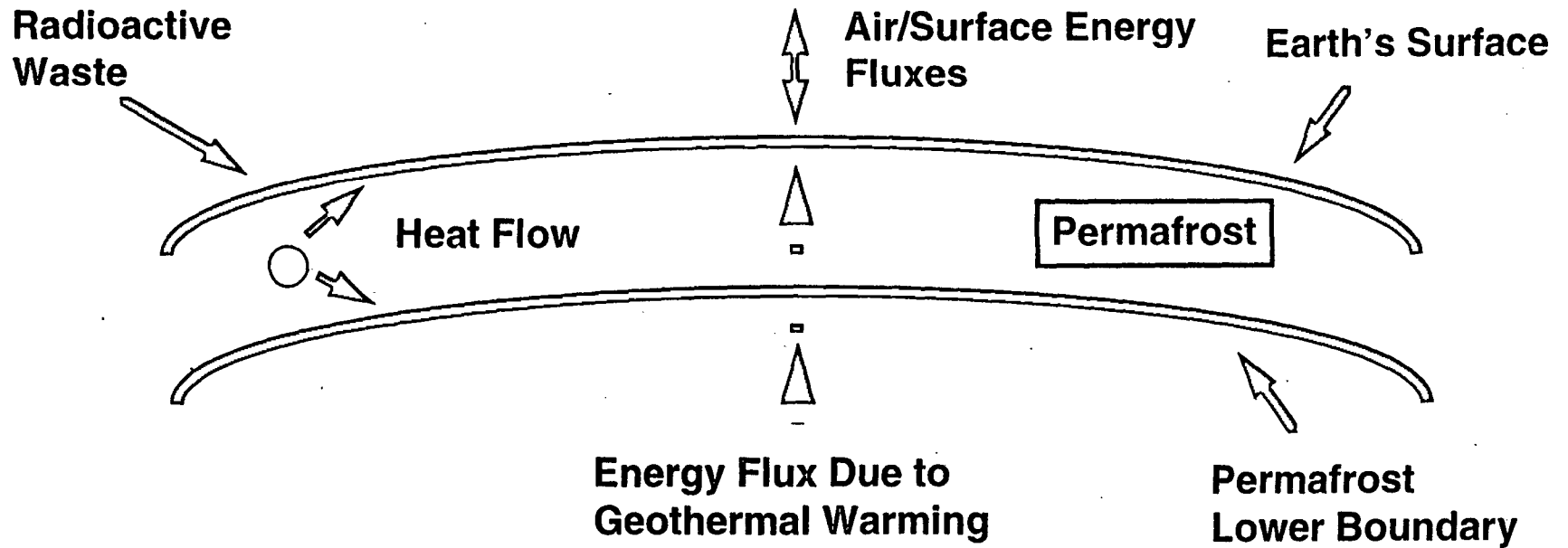

## Three designs

- A-type: Capped trenches for short-lived low-level radioactive solid waste
- B-type: Permafrost tunnels for short-lived intermediate-level radioactive waste
- C-type: Deep shafts to store short-lived and long-lived high-level radioactive wastes

## Advantages

- Geophysical properties  
Energy loss, impermeable, strength, self-healing,
- Proximity to RW sources at Murmansk and Severodvinsk
- Much of the appropriate staff and equipment are on site
- General acceptance by Russian environmental stakeholders

# Disadvantages

- Coastal site-international concerns
- Uncertainty of global climate change
- Novel solution
  - Limited benefit from lessons learned at more conventional sites
  - Many of the necessary conceptual and simulation tools are in their infancy
  - Model verification is problematic
  - Risk assessment is problematic
  - Obtaining IAEA approval could be difficult

## Work at CRREL

M.V. Mironenko of the Vernadsky Institute  
of Geochemistry and Analytical Chemistry  
at CRREL in 1995 and 1997  
Geochemical/Physical-Chemical Aspects

- Speciation/Phase Equilibria if leaks occur
- Liquid-water contents  $f(S, V; T, x)$
- Corrosion

# Speciation/Phase Equilibria

Assemble the standard Gibbs energies of formation for selected uranium and plutonium solids to 273.15 K and aqueous species to 298.15 K.

# Corrosion

Site is limestone in which a siderite patina will form on the container surface, isolating the inside of the container wall from the rock solution.



Liquid-water contents  $f(S, V; T, x)$

Measurement and modeling of electrolyte  
solution densities

## Summary

Proposed radioactive waste isolation project provides an excellent opportunity for international collaboration on a set of fundamental scientific and technical issues.

# Hydraulic Characterization: A History of Ideas

**T.N. Narasimhan**

Materials Science and Engineering

Earth Sciences Division

E.O. Lawrence Berkeley National Laboratory

July 8 - 9, 1997

## **JOINT RUSSIAN-AMERICAN HYDROGEOLOGY SEMINAR**

Russian - American Center for Contaminants Transport Studies

Ernest Orlando Lawrence Berkeley National Laboratory

Berkeley, California 94720

**HYDRAULIC CHARACTERIZATION:  
A HISTORY OF IDEAS**

**T.N. NARASIMHAN  
MATERIALS SCIENCE AND ENGINEERING  
EARTH SCIENCES DIVISION, LBNL  
UNIVERSITY OF CALIFORNIA AT BERKELEY**

**U.S. - RUSSIA HYDROGEOLOGY WORKSHOP  
BERKELEY, CALIFORNIA  
JULY 8, 1997**

# BASIS FOR CHARACTERIZATION

## FOURIER'S HEAT CONDUCTION EQUATION

- CONDUCTIVITY (*SPECIFIC CONDUCTIBILITY!*)
- CAPACITANCE (STORATIVITY)

## PRE-DARCY ERA: 1660 - 1850

1659: FIRST MERCURY THERMOMETER

1786: LAVOISIER AND LAPLACE: SPECIFIC HEAT  
VALUES USING ICE CALORIMETER

1807: FOURIER'S UNPUBLISHED MONOGRAPH

1827: OHM DEFINES ELECTRICAL RESISTIVITY

1839: HAGEN'S WORK ON CAPILLARY TUBES

1846: POISEUILLE'S WORK ON CAPILLARY TUBES  
(0.1 CC OVER SEVERAL HOURS)

## MIDDLE 19<sup>TH</sup> CENTURY

FOURIER:  $F = -K (dv/dz)$

OHM:  $E = I/R$

POISEUILLE:  $Q = KP, K = K(L, D, T); Q = K(PD^2/L)$

NEWTON, MAXWELL, JACOBSON, MATHIEU:

$$Q = (\pi P R^4)/(8 \mu L)$$

$$\mu = (\pi P R^4)/(8 Q L)$$

## SECOND HALF OF 19<sup>TH</sup> CENTURY

- 1856: DARCY'S LAW (ADDS GRAVITY)
- 1863: DUPUIT'S WORK ON FREE SURFACE FLOW
- 1898: FORCHHEIMER AND SLICHTER SOLVE LAPLACE EQUATION FOR A VARIETY OF SEEPAGE PROBLEMS



## THE TURN OF THE CENTURY

- 1904: BUCKINGHAM: RESPONSE OF AIR PRESSURE IN SOILS TO BAROMETRIC PRESSURE CHANGES
- 1907: BUCKINGHAM: DEFINES CAPILLARY POTENTIAL
- 1911: GREEN AND AMPT: INFILTRATION FRONT

## THE 1920'S

- 1921: CARSLAW: HEAT FLOW SOLUTIONS
- 1921: GARDNER AND WIDTSOE: DIFFUSION EXPERIMENT IN SOILS
- 1922: GARDNER: TENSIOMETER INVENTED
- 1924: TERZAGHI'S MODERN SOIL MECHANICS
- 1928: MEINZER: COMPRESSIBILITY OF AQUIFERS
- 1928: WEBER: TRANSIENT FLOW TO A WELL

## THE 1930'S

- 1931: RICHARDS: NON-LINEAR DIFFUSION EQN.
- 1932: WYCKOFF AND MUSKAT: GRAVITY FLOW
- 1933: RAPPEL: LAND SUBSIDENCE, SAN JOSE
- 1934: MUSKAT, HURST: NON-STEADY FLOW OF GAS AND OIL TO WELLS
- 1935: THEIS: TRANSIENT RADIAL FLOW TO WELL
- 1937: MEINZER: GROUNDWATER MINING AND LAND SUBSIDENCE

## THE 1940'S

- 1940: JACOB: PHYSICAL BASIS OF STORATIVITY
- 1940: HUBBERT: THEORY OF GROUND-WATER MOTION
- 1946: JACOB: LEAKY AQUIFER SYSTEMS
- 1947: JACOB: WELL EFFICIENCY
- 1949: VAN EVERDINGEN AND HURST: WELL-BORE STORAGE AND SKIN EFFECTS

## THE 1950'S

- 1952: KLUTE: SOLVING NON-LINEAR DIFFUSION EQUATION
- 1954: BOULTON: DRAINAGE KINETICS
- 1957: HUBBERT AND WILLIS: HYDRAULIC FRACTURING

**THE 1960'S**

**1960: BARENBLATT ET AL: SEEPAGE IN FISSURED  
ROCKS**

**1963: WARREN AND ROOT: NATURALLY  
FRACTURED RESERVOIRS**

**1965: COOPER ET AL: INERTIAL EFFECTS IN WELLS**

**1967: BREDEHOEFT: RESPONSE OF WELLS TO  
EARTH TIDES**

## 1970 - PRESENT

- INCREASED ATTENTION TO CONTAMINATION PROBLEMS
- HYDRODYNAMIC DISPERSION
- UNDERSTANDING UNCERTAINTY

**Potential remediation measures  
at Mayak site**

**Parker, F. L.**  
Vanderbilt University

July 8 - 9, 1997

**JOINT RUSSIAN-AMERICAN HYDROGEOLOGY SEMINAR**

Russian - American Center for Contaminants Transport Studies  
Ernest Orlando Lawrence Berkeley National Laboratory  
Berkeley, California 94720



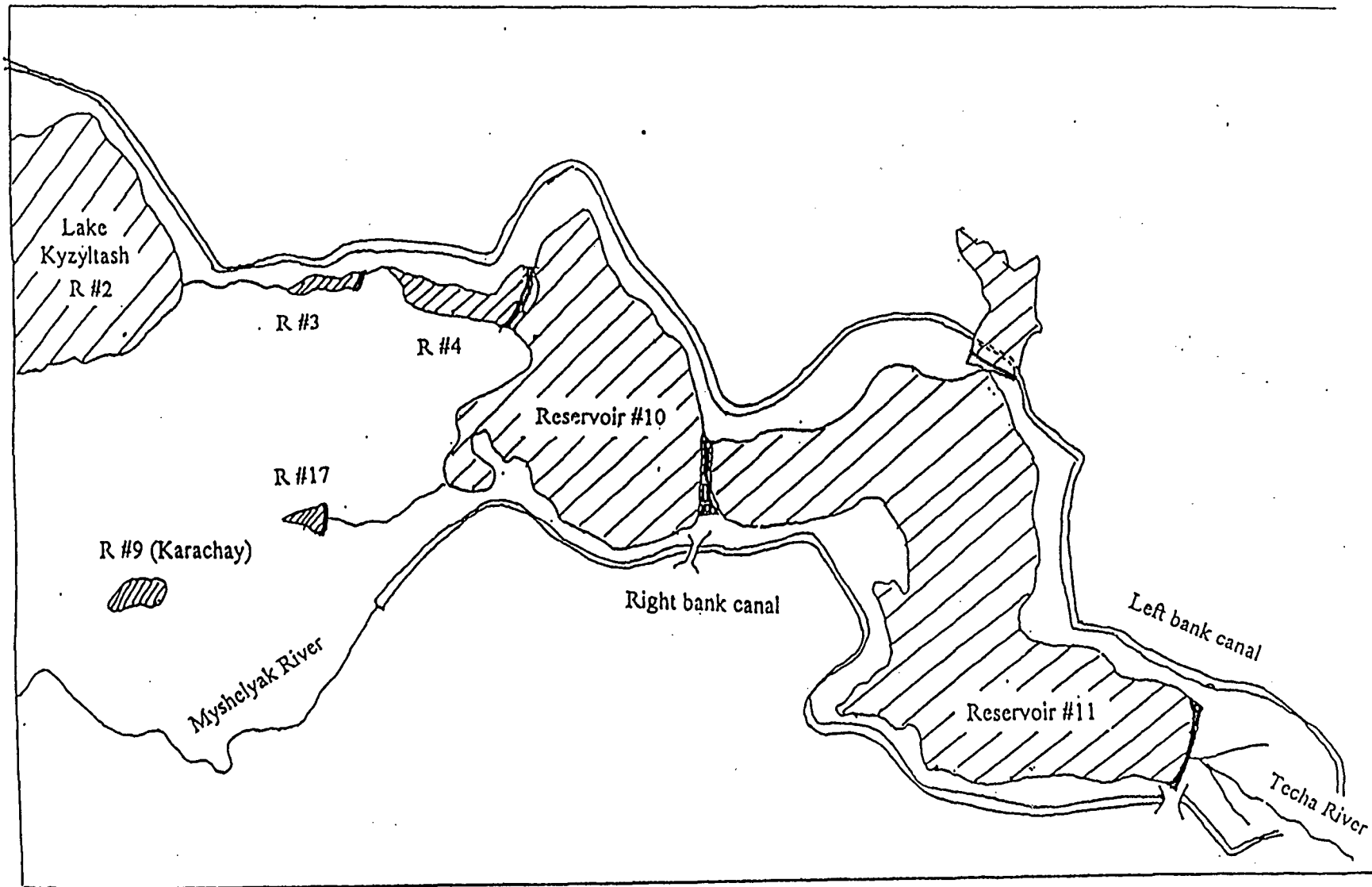
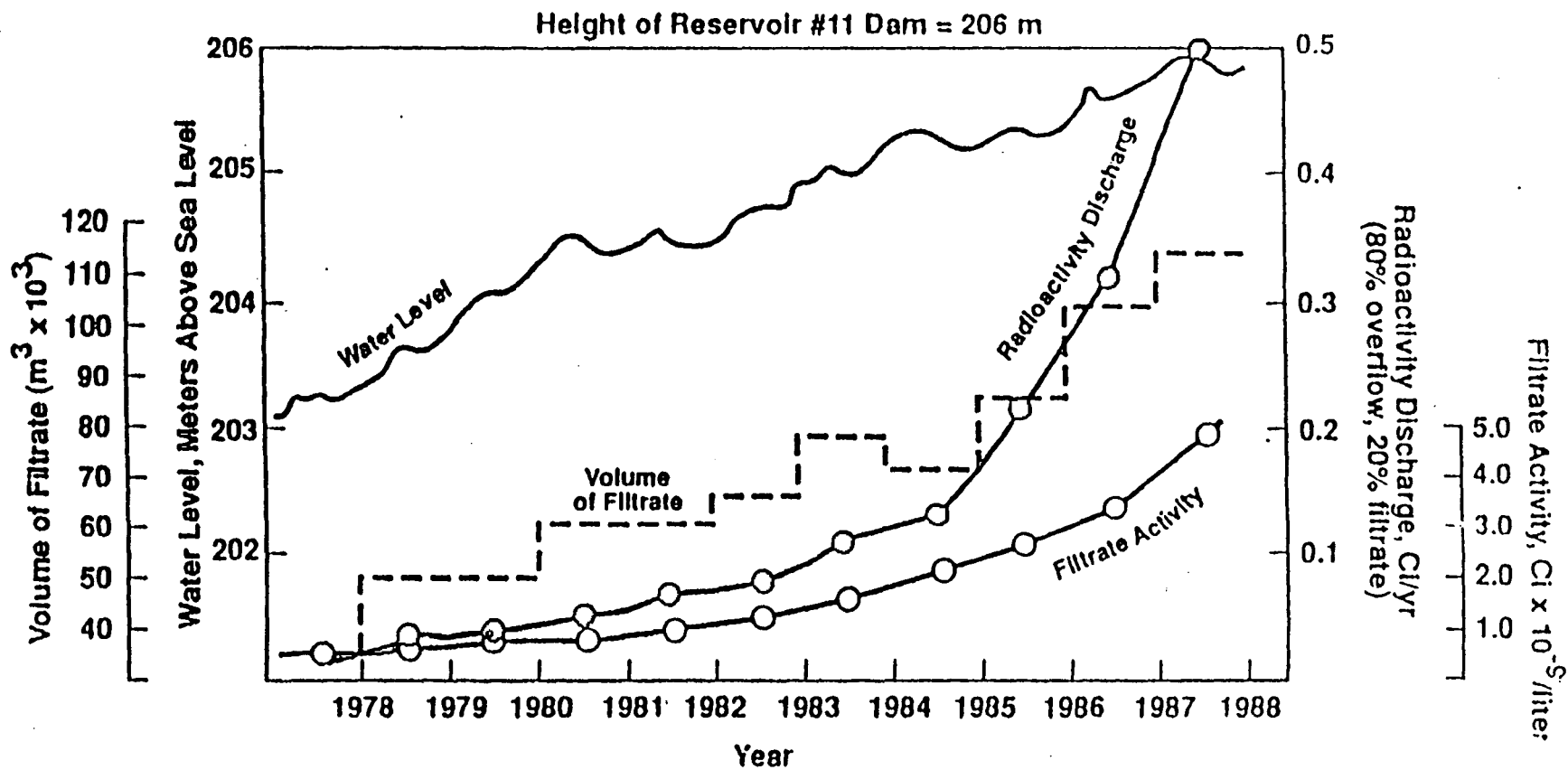

Figure 3.2. The sheme of "Mayak" contaminated reservoirs.

# CONTENTS OF RESERVOIRS 10 AND 11 TECHA RIVER

Reservoir	Volume $10^6 \text{ m}^3$	Radioactivity kCi
10	77	230
11	230	26



Characteristics and Radioactivity Discharges from Reservoir #11 near Chelyabinsk-65 (Environmental Workshop, October 1991)

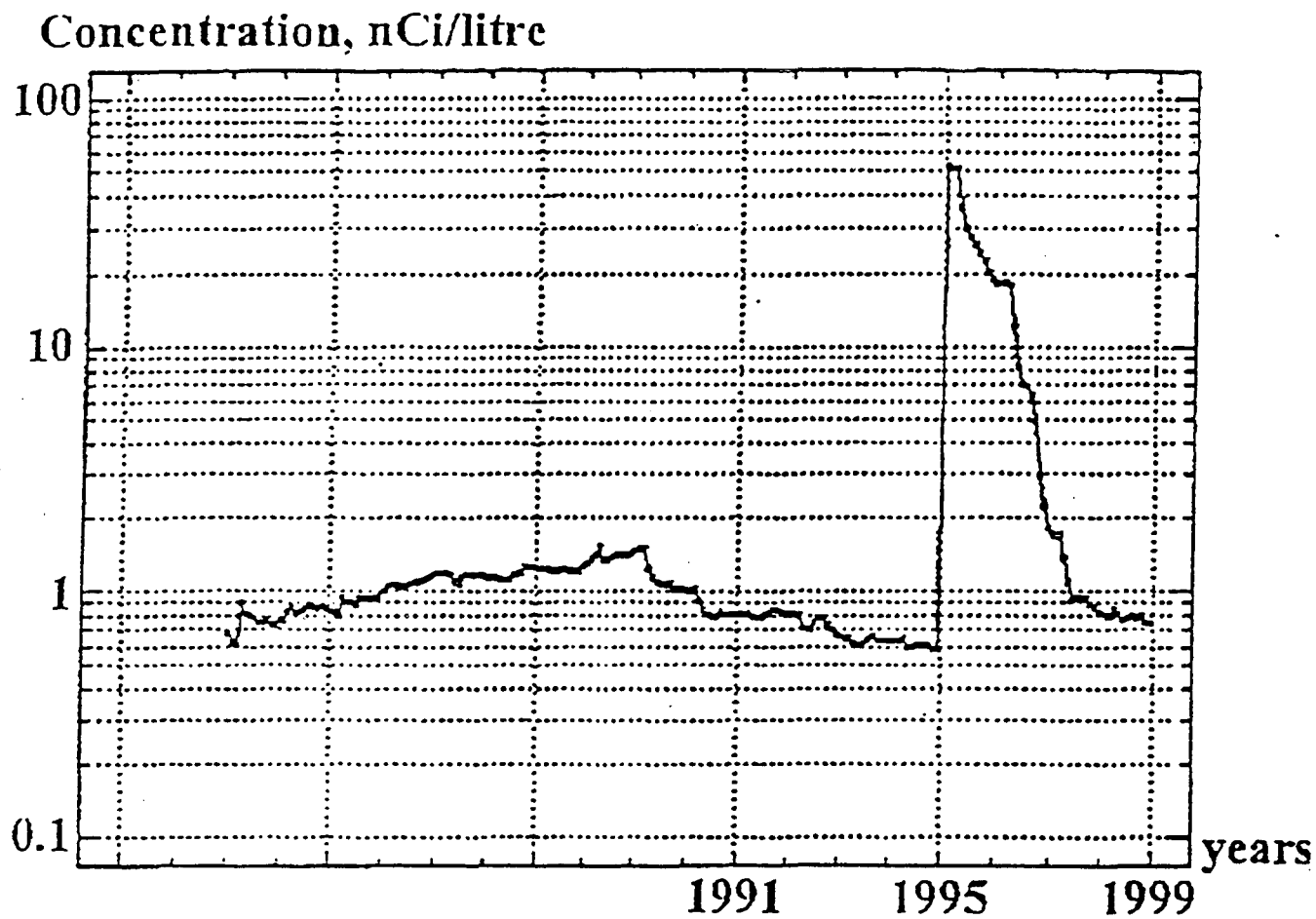
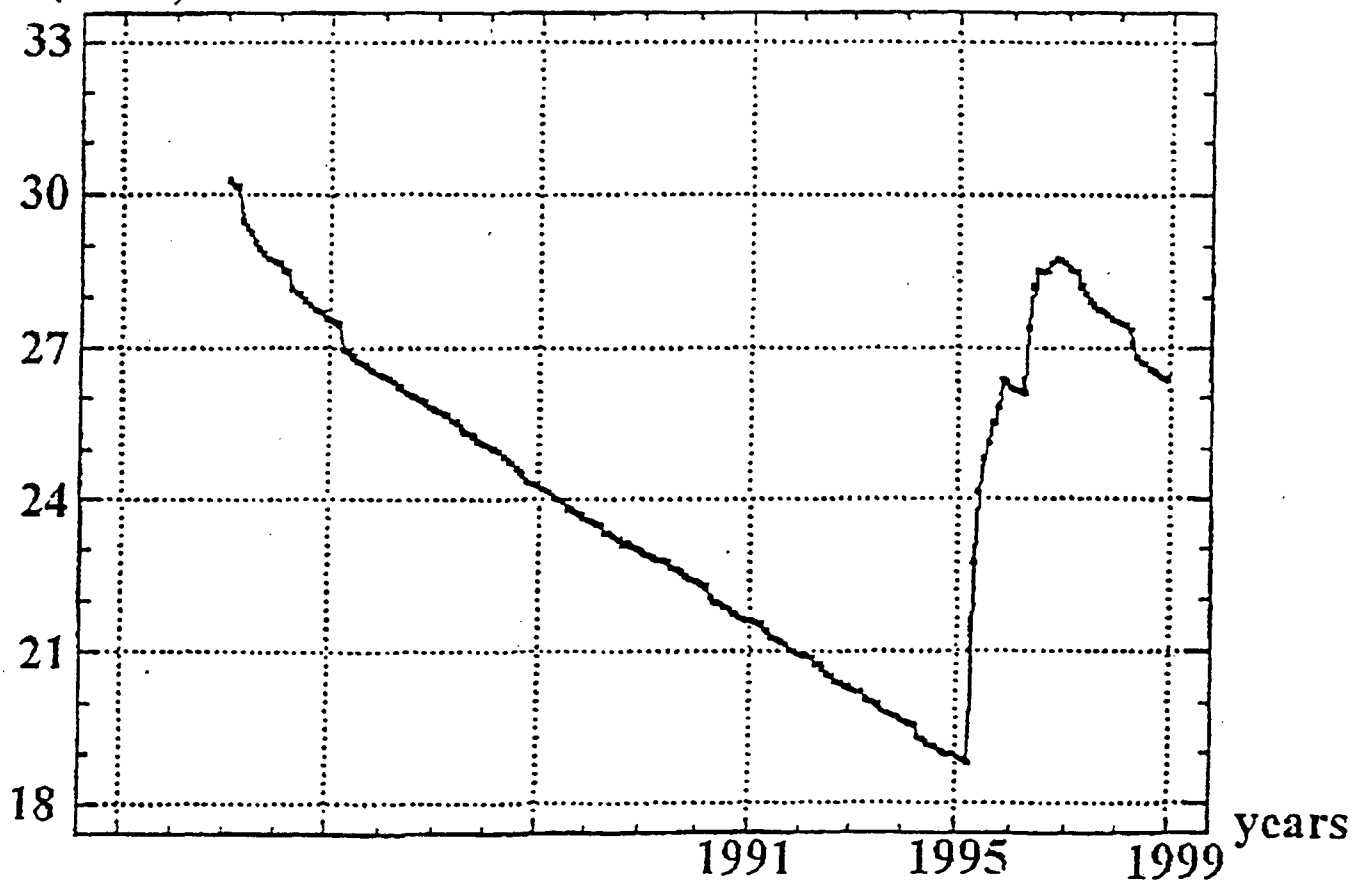

Fig. 5.6. Time dependence of  $^{90}\text{Sr}$  concentration in the Techa River water at the settlement Muslyumovo location.

Radioactivity, Ci  
(x 100)



Time dependence of the total amount of  $^{90}\text{Sr}$  accumulated in the Techa River flood-lands in the interval between dam N11 and settlement Musyumovo.

## COMPARISON OF FLOOD FLOWS IN THE TECHA RIVER BELOW DAM NO. 11

Settlement	River km below dam	HEC-6		BREAK 2	
		max depth, m	time, hr	max depth, m	time, hr
Muslyumovo	40.9	6.1	14.6	12.3	15.1
Brodokalmak	72.4	6.1	17.7	7.3	20.7
Russkaya Techa	96.9	6.4	30.8	7.4	26.8

# RESRAD DOSE CALCULATIONS

100 MREM/YR

	$^{90}\text{Sr}$	$^{137}\text{Cs}$
<b>external</b>	-	72
<b>plant</b>	7.8	14
<b>meat</b>	3.2	36
<b>milk</b>	9.5	13

## Failure of Earthen Dams

	Percent
Seepage	40
Hydraulic Problems	40
Structural Deficiencies	30

---

\*Committee on the Safety of Existing Dams, Safety of Existing Dams: Evaluation and Improvement. Washington, D.C.: National Academy Press, 1983.



# Remediation of Cascades

## I. Russian Studies

A. Bol'schakov

B. Romanov

C. Petukhov

## II. Workshop Suggestions

## III. IIASA Studies

A. Lower level of water in  
Reservoirs 10 and 11

B. Strengthen dams at Reservoirs

C. Stabilize bottom sediments in  
reservoirs

D. Monitoring & warning systems

A. Lower level of water in  
reservoirs 10 and 11

1. Natural means

- a. Modify  
hydrometeorological  
processes - suppress  
precipitation
- b. Modify solar radiation  
transfers - increase winter  
sublimation of snow

# ALBEDO OF SNOW AND EVAPORATION

**10<sup>6</sup>TONS**

<b>FRESH DRY SNOW</b>	<b>0.85-0.95</b>	<b>0.46</b>
<b>CLEAN DUMP SNOW</b>	<b>0.60-0.70</b>	
<b>DIRTY SNOW</b>	<b>0.40-0.50</b>	<b>1.29</b>
<b>SNOW WITH CARBON BLACK LAYER</b>		<b>2.01</b>

**Comments on presentation of F. L. Parker:  
"Potential remediation measures  
at the Mayak site "**

**Drozhko Eu. G.**  
Production Association 'MAYAK'

July 8 - 9, 1997

**JOINT RUSSIAN-AMERICAN HYDROGEOLOGY SEMINAR**

Russian - American Center for Contaminants Transport Studies  
Ernest Orlando Lawrence Berkeley National Laboratory  
Berkeley, California 94720

1. The prediction of the population exposure to radioactivity reported in this presentation seems to be overestimated in comparison with the most real situation because: a ) for an optimistic case of flood wave propagation from dams 10 and 11 (laminar flow and sediment transport) the downstream transport of bottom sediments from the reservoirs to the Techa River will take place at the latest stage of flooding, so all sediments will be deposited not far from the reservoirs in the upper part of the Techa valley, .i.e., in places without any settlements. b) for a pessimistic case of flood wave propagation (the most dangerous situation) sediments will be redistributed and deposited along the entire length of the Techa and Iset rivers. The estimations of radioactive population exposure seem to me to be overvalued, but it is not too easy to give a quantitative analysis of this presentation because some input data and methods of dose calculations are not shown. The author also should take into account that emergency protective measures will be taken in the case of flood wave propagation from the reservoirs. These will decrease the population radiation impact.

2. The assessment of dams 10 and 11 failure risk given in the table should be critically reevaluated, because the protective measures and monitoring of dams and their environs should be taken into account. These measures include reenforcing the dams. The results presented by prof. Parker can be used to plan the Special Forces actions in the critical time of dam failure and flood wave propagation. These results cannot be used for estimations of radioactive population exposure due to bottom sediment redistribution after the failure. The time scale of the presented results is the characteristic time of wave propagation modeled by Sen-Venan's equation. Beyond this time scale, the radioactive population exposure should be considered, taking into account the population evacuation from the risk zone, and restriction of agricultural and economic activities within all the effected region after the flood.

3. The "philosophy" of the remediation measures proposed by IIASA is quite acceptable. The main tasks of the remediation efforts are well known:

a) we stabilize and decrease the water level in reservoirs; b) begin reinforcing the dams; c) systematically conduct research and development to immobilize the reservoir bottom deposits. The expense of this latter proposed action, which demands great effort and still cannot guarantee clear results, I suppose, makes its conduct problematical.

4. Finally, the proposal to alter the regional climate, in order to change the ratio of precipitation to evaporation seems absolute fantasy. It is not only technically not reasonable, but it is unacceptable from an environmental point of view. Strictly speaking, I do not want to discuss the variant of the Urals region being changed into a Sahara Desert. Protective works to stabilize the environmental situation at the Mayak site are presently being carried out. If appropriate funding for this environmental work continues, it will permit not just the stabilization, but also the remediation. This work includes the following:

a) decreasing the waste influx into Lake Karachai in order to allow the covering of its surface,

b) elimination of the free surface of Lake Karachai by covering and management of local surface and underground runoff of precipitation. This allows elimination of the risk of aerosol transport of radionuclides due to winds and tornadoes. It also allows us to decrease the impact of the lake on surface and ground water. The results of 3-D predictive modeling of flow and contaminant transport in ground water, taking into account the lake's impact with ground water, show the reasonableness of these measures. It was shown by modeling that after eliminating the lake, radionuclide discharge into surface water (the Mischelyak River and reservoirs) is not very intensive. The calculated maximum dose of population exposure does not exceed the critical value.

c) In order to stabilize the water level and water balance in the system of Techa River reservoirs, the following measures are considered:

(i) drainage of ground water flow that discharges into the reservoir. The system of drainage wells has already been constructed and it will start operating soon.

(ii) discharge of sanitary water and ground water into the left bank canal instead of into the reservoirs. The design of this discharge system is underway.

- (iii) radiochemical treatment of reservoir water and technical water that enters the reservoirs from facilities, in order to decrease the radioactivity of the water to below the critical value; research and development are being conducted.
- (iv) the realization of remediation of the Techa system reservoirs depends on future construction of the South Urals Nuclear Power Plant.

These are all my comments on Prof. Parker's presentation.

**Class I Deep Well Injection  
Nature's Subsurface Treatment of Injected Waste**

**James E. Clark, Jr.**  
E.I. du Pont de Nemours and Company, Inc.  
Beaumont, Texas

July 8 - 9, 1997

**JOINT RUSSIAN-AMERICAN HYDROGEOLOGY SEMINAR**

Russian - American Center for Contaminants Transport Studies  
Ernest Orlando Lawrence Berkeley National Laboratory  
Berkeley, California 94720



# **CLASS I DEEP WELL INJECTION NATURE'S SUBSURFACE TREATMENT OF INJECTED WASTE**

James E. Clark, Jr.  
E.I. du Pont de Nemours and Company, Inc.  
P.O. Box 3269  
Beaumont, Texas 77704

## **ABSTRACT**

Injected liquid wastes undergo various reactions with the natural geologic formations and minerals thousands of feet below the earth's surface in the injection zone. These wastes are either degraded or neutralized over time and nature's subsurface treatment reduces any potential impact on the environment. The injection zone formation minerals can render the waste non-hazardous by neutralizing the acidity or alkalinity of the waste stream soon after injection. These mechanisms include carbonate dissolution with acidic waste, sand dissolution by alkaline aqueous solutions, and clay/feldspar dissolution with both acidic and alkaline aqueous solutions. Case studies include the Gulf Coast formations sands and the Appalachian Valley and Ridge Providence of carbonate rocks. Chemical transformation of waste constituents into non-hazardous fluid can also occur over time by other reactions, such as hydrolysis (reaction with water), ion exchange, adsorption, co-precipitation and microbial degradation. These reactions can be predicted using standard chemical engineering approaches. The subsequent reactions depend on the nature and temperature of the injected waste and the physical and chemical properties of the injection zone. While the nature of the waste, the geology and the interactions differ from facility to facility, these studies concluded that the injected waste reacts with the fluids and minerals in the injection zone and is ultimately neutralized or reduced in hazard. This concurs with EPA's 1988 final rules concerning underground injection control program; hazardous waste disposal injection for Class I wells. These rules concluded that a 10,000 year time period concerning a no-migration demonstration would allow time for geochemical transformations which would render the waste non-hazardous or immobile.

## WELL CONSTRUCTION LOGGING/TESTING AND WELL CERTIFICATION

<u>Log/Survey Type</u>	<u>Results</u>
<b>Open Hole Logs</b>	
Electric Log <ul style="list-style-type: none"> <li>• Spherically Focus Log</li> <li>• Gamma Ray Log</li> <li>• Micro Resistivity</li> <li>• SP Resistivity</li> <li>• Lateralog</li> </ul>	Lithology determination, formation salinity, waste plume encounters, permeability indicator
Porosity <ul style="list-style-type: none"> <li>• Neutron Density</li> <li>• Sonic</li> </ul>	Lithology determination, formation porosity, fracture evidence
Caliper	Hole size
Fracture Finder	Geologic bed dip, discontinuity, heterogeneity, depositional history, fault & fracture determination, thickness, fault throw, & gouge data
Coring <ul style="list-style-type: none"> <li>• Whole Cores</li> <li>• Sidewall Cores</li> </ul>	Reservoir lithology, laboratory quantitative permeability analysis
Formation Tester	Formation fluid recovery, formation pressure testing, formation pressure gradients, formation permeability analysis (k), chemical constituent analysis, fluid-specific gravity, TDS
Sonar Caliper	Formation cavern dimensions, fracture delineation
Vertical Seismic Log	Subsurface structure evaluation, fault verification, stratigraphic interpretation
<b>Cased-Hole Logs</b>	
Bottom Hole Pressure Survey <ul style="list-style-type: none"> <li>• Injection</li> <li>• Falloff</li> </ul>	Formation transmissivity (kh), permeability (k), geologic boundary determination, faults-dual porosity-heterogeneity
Flowmeter	Injection-interval profile, flow interval percent distribution, completion efficiency
Gradiomanometer	Fluid-density variations
Fluid Flow Surveys <ul style="list-style-type: none"> <li>• Temperature Survey</li> <li>• Radioactive Tracer Survey</li> <li>• Oxygen Activation (OA)</li> <li>• Noise Log</li> </ul>	Prove fluid zone isolation, profile of behind-casing fluid flow, waste fluid interval top, quantify fluid flow & direction
Casing/Cement Evaluation <ul style="list-style-type: none"> <li>• Log Acoustic Cement Bond</li> <li>• Cement Evaluation</li> <li>• Ultra-Sonic Imager</li> </ul>	Injection interval/zone isolation, waste emplacement/confinement, cement bond sheath, quantitative cement analysis, profile cement & casing integrity
<ul style="list-style-type: none"> <li>• Thermal Decay Time</li> </ul>	Determine top of cavity

## WELL MONITORING LOGGING AND TESTING METHODS FOR HAZARDOUS WELLS

<u>Logging/Testing Method</u>	<u>Results</u>	<u>Frequency</u>
Annulus Pressure Test, Liquid or Gas	Determine significant leak in casing, tubing or packer	Annually, or after any major well workover which involves pulling injection tubing, or loss of well mechanical integrity
Fluid Flow Surveys <ul style="list-style-type: none"> <li>• Temperature Survey</li> <li>• Radioactive Tracer Survey (RTS)</li> <li>• Oxygen Activation (OA)</li> <li>• Noise Log</li> </ul>	Determine if any fluid movement occurs through vertical channels adjacent to the well bore, demonstrate zone isolation, demonstrate fluid profile behind-casing, if any, and determine waste fluid interval top and quantify fluid flow	Annually conduct RTS survey, or after any well workover which involves pulling injection tubing or loss of well mechanical integrity. Once every 5 years run temperature log over entire injection casing interval to determine movement of fluid along the borehole
Sonar Caliper	Formation cavern dimensions, fracture delineation	Annually
Bottom Hole Pressure Survey <ul style="list-style-type: none"> <li>• Injection</li> <li>• Falloff</li> </ul>	Formation transmissivity (kh) Permeability (k) Geologic boundary determination, Faults-dual porosity-heterogeneity	Annually
Flowmeter	Injection-interval profile Flow interval percent distribution, Completion efficiency	Annually
Gradiomanometer	Fluid-density variations	Annually
Casing/Cement Evaluation Logs <ul style="list-style-type: none"> <li>• Acoustic Cement Bond</li> <li>• Cement Evaluation</li> <li>• Ultra-Sonic Imager</li> </ul>	Injection interval/zone isolation, waste emplacement/confinement, quantitative cement analysis, profile cement & casing integrity	Once every 5 years conduct casing evaluation log unless waived by the permit agency. Also can be required when injection tubing is pulled
Thermal Decay Time	Determine top of cavity	Annually
Corrosion Monitoring	Determine comparability of waste fluid with well materials. A coupon is placed so that it is exposed to the waste stream.	Annually
Annulus Pressure & Fluid Tank Levels	Annulus pressure is monitored to ensure no significant leak in the casing, tubing or packer. Fluid tank levels are measured to ensure no significant leaks exist in the annulus.	Continuously monitor annulus pressure and daily monitor fluid tank levels to ensure no significant leaks in the annulus system

## REFERENCES

1. Apps, J.A., *An Approach to Modeling the Chemistry of Waste Fluid Disposal in Deep Saline Aquifers*, Deep Injection Disposal of Hazardous and Industrial Waste; Scientific and Engineering Aspects, Academic Press, pp. 465-488, 1996.
2. Brower, R.D., A.P. Visocky, I.G. Krapac, B.R. Hensel, G.R. Peyton, J.S. Nealon, M. Guthrie, *Evaluation of Underground Injection of Industrial Waste in Illinois*, Illinois State Geological Survey, Illinois State Water Survey, Hazardous Waste Research and Information Center, 1989.
3. CH<sub>2</sub>M Hill, *Class I Injection Well Survey-Phase I Report; Survey of Selected Sites*, presented to Underground Injection Practices Council, Oklahoma City, Okla., 1986.
4. Clark, James E., *Groundwater Flow in Deep Saline Aquifers*, presented to American Geophysical Union, Baltimore, MD, May 1988 and published in Proceedings of the International Symposium on Class I & II Injection Well Technology, Underground Injection Practices Council, Dallas, Texas, 1989.
5. Clark, James E., A. Klingensmith, P. Hegeman, F.T. Fischer, *Multiple Well Testing and Computer Simulation to Characterize Hydrologic Properties of the Injection and Containment Intervals*, presented to American Geophysical Union, Baltimore, MD, May 1991.
6. Clark, James E., *Environmental Scoring Without Risk Assessment*, presented at the Underground Injection Control Workshop and published in Texas Natural Resource Conservation Commission, Environmental Trade Fair 94, Clean Texas 2000, Austin, Texas, April 14, 1994.
7. Engineering Enterprises, Inc., 1986, *Class I Hazardous Injection Well Evaluation of Non-Compliance Incidents*, prepared for U.S. EPA, Office of Drinking Water, 1986.
8. Federal Register, *Underground Injection Control Program: Hazardous Waste Disposal Injection Restrictions and Requirements for Class I Wells; Finale Rule*, (40 CFR Parts 124, 144, 146, and 148), July 26, 1988.
9. Fischer, F.T., C. Miller, J.E. Clark, Diane Sparks, *Demonstration of Presence and Size of a CO<sub>2</sub>-Rich Fluid Phase After HCl(aq) Injection in Carbonate Rock at Louisville, Kentucky*, presented to American Geophysical Union, Baltimore, MD, May 1991.

10. LaMarca, C., N.C. Scrivner, L.U. Gron, B.J. Izzo, A. Chu, M.T. Klein, *Hydrolysis of Nitriles: Experiments and Modeling*, Deep Injection Disposal of Hazardous and Industrial Waste; Scientific and Engineering Aspects, Academic Press, pp. 601-610, 1996.
11. Larkin, R.G., J.E. Clark, P.W. Papadeas, *Comparison of Modeled Disposal Well Plumes Using Average and Variable Injectate Densities*, Groundwater 32(1), pp. 35-40, 1994.
12. Larkin, R.G., J.E. Clark, and P.W. Papadeas, *Modeling the Effect of Injectate-Density Changes on Disposal Well Plumes*, Deep Injection Disposal of Hazardous and Industrial Waste; Scientific and Engineering Aspects, Academic Press, pp. 381-402, 1996.
13. Miller, Chet, J.E. Clark, Chuck Hales, T.A. Fischer II, W.M. Porter, J.R. Tilton, *Flow and Containment of Injected Wastes*, presented to Underground Injection Practices Council, New Orleans, LA, 1986 and published in Groundwater Monitoring Review, Vol. 6 No. 3, p. 37-48, 1986.
14. Miller, Chet, *Modeling Molecular Diffusion in No-migration Demonstration*, prepared for American Geophysical Union, Baltimore, MD, May 1991.
15. Nopper, R.W., Jr., C. Miller, C.H. Hales, *Stability Analysis of a Solution Cavity Resulting from Underground Injection at Louisville, Kentucky*, published in Proceedings of the UPIC, 1991 Winter & Summer Meetings and presented to the Underground Injection Practices Council, Reno, Nevada, 1991 and American Geophysical Union, Baltimore, MD, May 1991.
16. Papadeas, P.W., D.K. Sparks, J.E. Clark, *Field Observations Validating Flow and Containment Modeling and Chemical Fate of Waste Injectate*, presented to American Geophysical Union, Baltimore, MD, May 1991.
17. Papadeas, P.W., *Field Testing for Model Confirmation: Case Histories from Du Pont*, Deep Injection Disposal of Hazardous and Industrial Waste; Scientific and Engineering Aspects, Academic Press, pp. 325-348, 1996.
18. Reeder, L.R., J.H. Cobbs, J.W. Field, W.D. Finley, S.C. Vokurka, B.R. Rolfe, *Review and Assessment of Hazardous Waste, Volume I*, prepared for U.S. EPA, Office of Research & Development, Cincinnati, Ohio, 1977.
19. Rege, S.D., H.S. Fogler, *Wormholing in Underground Injection Strata*, presented to the Underground Injection Practices Council and published in Proceedings of the UIPC 1991 Winter & Summer Meetings, Reno, Nevada, July 28-31, 1991.

20. Scrivner, Noel C., Karl Bennett, Richard Pease, Alex Kopatsis, Steven Sanders, Diane Clark, Marshall Rafal, *Chemical Fate of Injected Wastes*, Groundwater Monitoring Review, Vol. 6 No. 3, pp. 53–58, 1986.
21. Stalzer, R.B., T.D. Thornton, *Reactivity and Fate of Acrylonitrile Process Wastewater on Deep-Well Injection*, Deep Injection Disposal of Hazardous and Industrial Waste; Scientific and Engineering Aspects, Academic Press, pp. 611–626.
22. Tsang, C.F., *Some Hydrologic Factors Affecting the Safety of Deep Injection Disposal of Liquid Wastes*, Deep Injection Disposal of Hazardous and Industrial Waste; Scientific and Engineering Aspects, Academic Press, pp. 35–45, 1996.
23. U.S. EPA, Office of Drinking Water, *Report to Congress on Injection of Hazardous Waste*, 1985.
24. U.S. EPA, Office of Solid Waste and Emergency Response, *OSWER Comparative Risk Project: Executive Summary and Overview (OSWER)*, Washington, D.C., 1989.
25. U.S. EPA, Office of Ground Water and Drinking Water, *Analysis of the Effects of EPA Restrictions on the Deep Injection of Hazardous Waste*, October 1991.
26. U.S. EPA, Office of Pollution Prevention and Toxics, *1990 Toxic Release Inventory Public Data Release*, Question and Answer Appendix, p. 193, 1992.
27. U.S. EPA, Office of Research and Development, *Assessing the Geochemical Fate of Deep-Well-Injected Hazardous Waste: A Reference Guide*, June 1990.
28. U.S. EPA, Office of Research and Development, *Assessing the Geochemical Fate of Deep-Well-Injected Hazardous Waste: Summaries of Recent Research*, July 1990.
29. Visocky, Adrian P., John Nealon, Ross Brower, Ivan Krapac, Bruce Hensel, Mark Guthrie, *Study of Current Underground Injection Control Regulations and Practices in Illinois*, Groundwater Monitoring Review, Vol. 6 No. 3, pp. 59–63, 1986.

**Arsenic in ground water of Minnesota:  
Hydrogeochemical modeling and regional trends**

**Kanivetsky R.**  
Minnesota Geological Survey

July 8 - 9, 1997

**JOINT RUSSIAN-AMERICAN HYDROGEOLOGY SEMINAR**

Russian - American Center for Contaminants Transport Studies

Ernest Orlando Lawrence Berkeley National Laboratory

Berkeley, California 94720

Arsenic is one of the chemical constituent specifically mentioned in the 1996 Amendments to the Safe Drinking Water Act. Currently, the federal standard for arsenic in public water supplies is 50 parts per billion (ppb). EPA officials have indicated that the arsenic standard may be lowered to between 2 ppb and 20 ppb. A knowledge of hydrogeochemical processes and hydrogeological distribution of elevated concentrations of arsenic in water is necessary for effective management of ground water in Minnesota.

Chemical analysis from Minnesota Pollution Control Agency Ground Water and Assessment Program, and geochemical data on geological materials from various previous studies in the state were used to study the arsenic nature and distribution. The elevated background content of arsenic in materials (17 - 26 ppm) were found from core samples of Quaternary sediments in western Minnesota. The arsenic in water exists mostly in two oxidized species as As(III) and As(V). However, the elevated arsenic concentration exists in the form of As(III) under mildly suboxic conditions ( $E_h = -200$  --  $+100$  mV). The EQ3 modeling showed that arsenic in water is highly undersaturated with respect to any arsenic minerals suggesting that its solubility is not controlled by arsenic-containing compound. MINEQL + adsorption model was used to study adsorption of arsenic on ferric hydroxides. Modeling and sensitivity analysis performed indicate that arsenic concentration and mobility is controlled at least partly by iron in solid phase. The species of As(III) in water were reasonably well correlated in case of the presence of sufficient quantity of arsenic and iron in the solid phase. For the highest arsenic content (91 ppb) in water the best convergence were achieved for arsenic of 45 ppm and iron of 2.5% in sediments. Dissolved arsenic shows no significant correlation with dissolved iron ( $R=0.12$ ). However, the depth distribution of total arsenic and iron in Quaternary sediments shows reasonable correlation ( $R=0.6 - 0.65$ ). Based on this analysis the state is divided into five hydrogeochemical domains.

The highest concentration of arsenic is in Quaternary Buried Aquifer System in which the arsenic is mobilized from sediments under mildly suboxic environment.

The source of the arsenic is presumably the parent fine till material with significant presence of iron hydroxides covering this domain. Further research is needed to verify



many aspects of modeling. The research should include: 1) detail sampling program to map spatial and temporal variability; 2) flow tube design to address in detail the geological, geochemical, hydrogeological and hydrochemical framework of high concentration of arsenic; 3) experimental measurements of sediments and fluids to verify or modify adsorption model.

## Arsenic in ground water of Minnesota

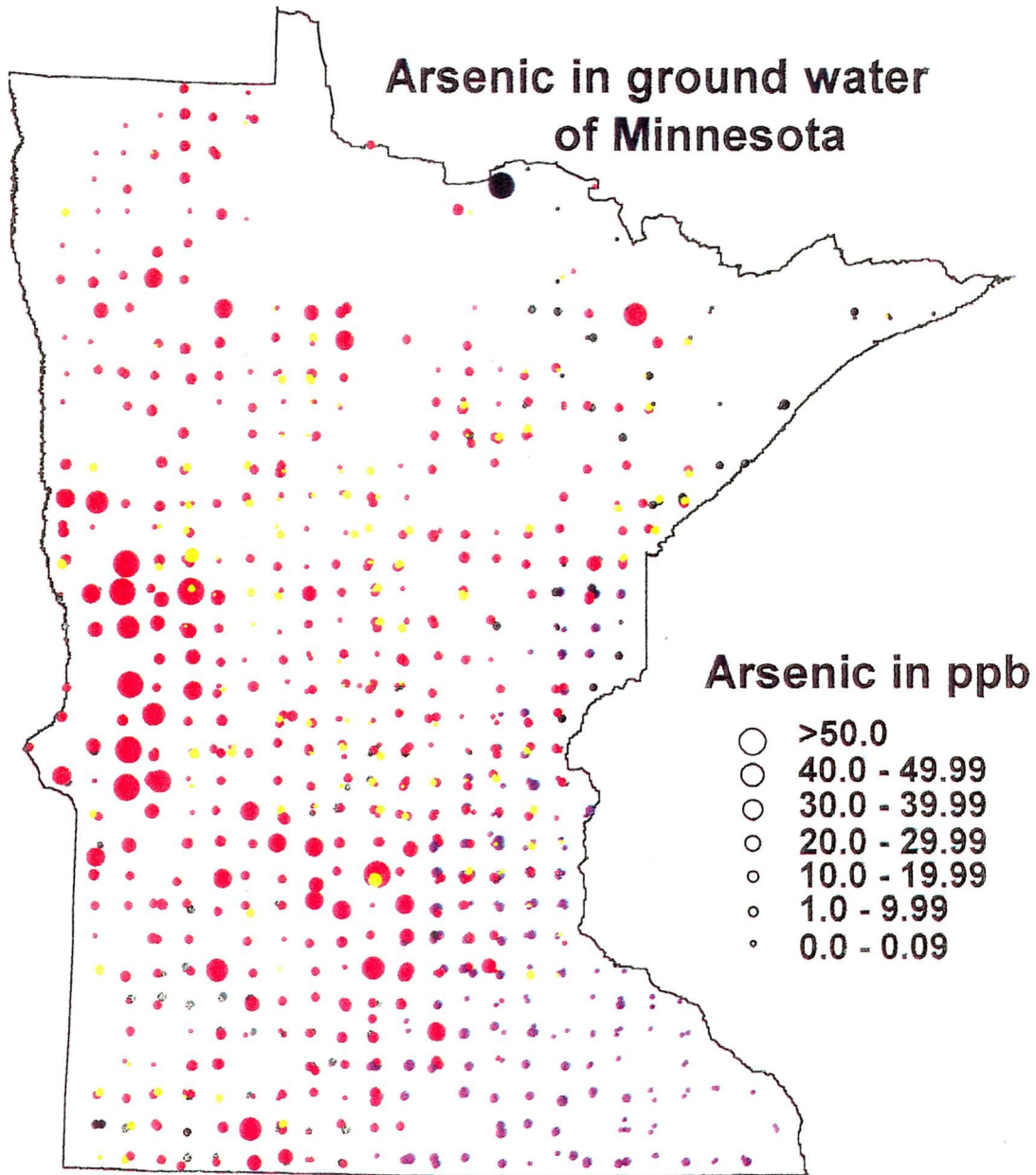

### Hydrogeochemical domains

- Quaternary Buried Artesian Aquifer System
- Quaternary Water-Table Aquifer System
- Cretaceous Aquifer System
- Paleozoic-Middle Proterozoic Artesian Basin
- Precambrian Crystalline Rocks

Cottonwood Co., rotonsonic #1  
(T. 107 N., R.38 W., S. 34)

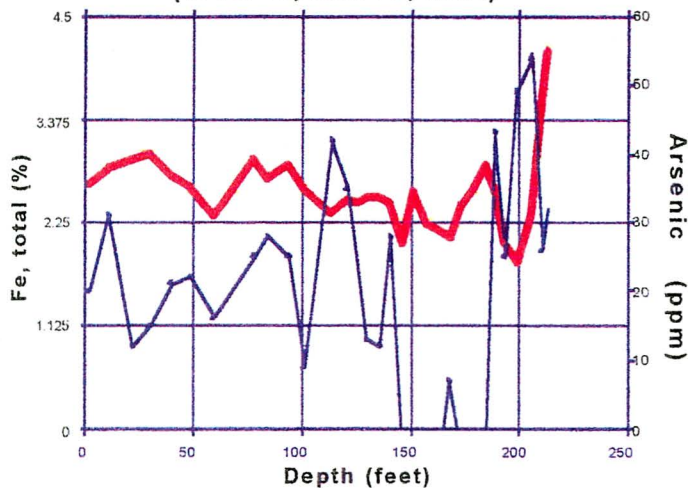

Rice Co., rotonsonic #3  
(T. 112 N., R. 22 W., S. 26)

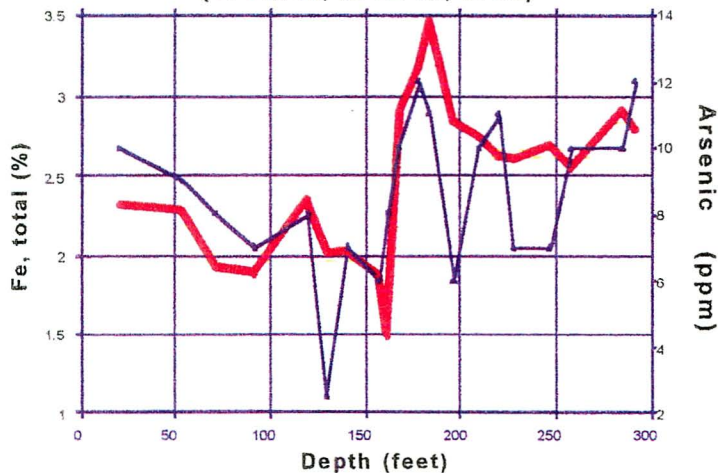

Stearns Co., rotonsonic #3  
(t 127 N., R 31 W., S. 5)

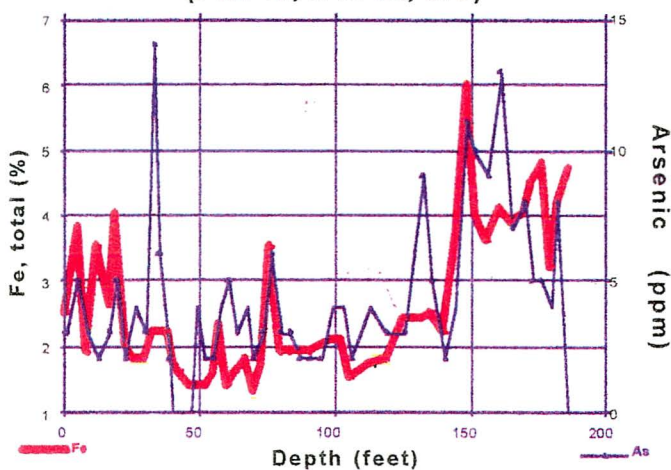

Fig. 3. Depth - distributions of total arsenic and iron in Quaternary sediments

Mineql+ (As modeling)

File name/well	input parameters total As&Fe3+ sedim.concentration	species modeled value in mole	field, ppb/ mole speciaton	%ads.	field& model agreement.	remarks
Mineql	AsO3=3.3E-3M (23.5 ppm As)	H3AsO3	92 ppb/3.6E-7	99	33%	As from reas SWRA1 well
#197795						
Ottertail 205	Fe3+=4.7 M(2.5%)	1.21E-07	H3AsO3		agreement.	int.49-130
197795 Ro	AsO3=1.9E-3M (13.2 ppm)		92 ppb/3.6E-7	99	order dif poor	sed. As low SWRA2 well
#197795						
Ottertail 205	Fe3+=4.7M(2.5%)	6.97E-08	H3AsO3		agreement.	int.104 -252
new mdo	AsO3=6.3E-3M (44.61ppm)		92ppb/3.6E-7	99	64%	As from good SWRA1
#197795						
Ottertail 205	Fe=4.7M(2.5%)	2.30E-07	H3AsO3		agreement.	int.189 -205
112844	AsO3=3.5E-3 (25ppm)		19.27/7.74E-8	100	86%	As from good SWRA1 well
#112844						
Cottonwood75	Fe3+=4.7M(2.5%)	9.00E-08	H3AsO3		agreement.	int.78 -130
138773	AsO3=3.5E-3 (25ppm)		15.38/6.15E-8	100	55%	As from reas. SWRA1
#138773						
Cottonwood 13	Fe3+=4.7M(2.5%)	1.11E-07	H3AsO3		agreement.	int.78 - 130
138773a	AsO3=4.0E-3M (28.5 ppm)		15.38/6.15E-8	100	order dif poor	As increased arbitrarily
#138773						
Cottonwood 13	Fe3+=4.7M(2.5%)	1.27E-07	H3AsO3		agreement.	
138773b	AsO3=1.9E-3M (13.2 ppm As)		15.38/6.15E-8	100	98%	As from good SWRA2 well
#138773						
Cottonwood 13	Fe3+=4.7M(2.5%)	6.04E-08	H3AsO3		agreement.	int.104 -252
163205a	AsO3=5.6E-3M (40ppm As)		5.49/2.2E-08	100	factor of 4	As increased arbitrarily
#163205						
Lyon 80	Fe3+=8.5M(4.5%)	8.69E-08	H3AsO3		differen.	K unit
163205b	AsO3=5.6E-4M (4 ppm)		5.49/2.2E-8	100	factor of 2.5	As from cuttings
#163205						
Lyon 80	Fe3+=8.5M(4.5%)	8.66E-09	H3AsO3		differ.	K-186 D.S.
163205c	AsO3=1.4E-3M (10 ppm)		5.49/2.2E-8	100	very good	As from cuttings
#163205						
Lyon 80	Fe3+=8.5M(4.5%)	2.17E-08	H3AsO3		agreement.	incr.2 times

# Well #197795 adsorption modeling on Fe<sup>3+</sup> hydroxides

## Output

Obs.≥	Species ID≥	Name≥	Type≥	Conc.≥	LogC≥	LogK≥	% Total≥
1	9	AsO3(3-)	1	9.56E-21	-20.02	0	0
1	255900	Fe(st)H2AsO3	2	7.75E-05	-4.111	38.67	2.3
1	256000	Fe(wk)H2AsO3	2	0.00322	-2.492	38.67	97.6
1	26600	HAsO3 -(-2)	2	7.87E-15	-14.104	12.92	0
1	26700	H3AsO3 -3	2	1.21E-07	-6.916	34.1	0
1	26800	H2AsO3 - (-1)	2	6.45E-10	-9.19	24.83	0
1	26900	H4AsO3 + (+1)	2	7.8E-16	-15.108	32.91	0
1	204000	ARSENOLITE	5	5.79E-25	-24.237	139.84	#####
1	204100	CLAUDETITE	5	9.57E-25	-24.019	140.06	#####

### For As(V)



### For As (III)

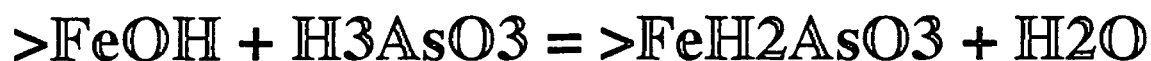

Well#112848, Nobles Co, depth 85 ft  
T. 101 R. 43 S.14  
QBAA (Low As=1.05ppb )

Input data EQ 3 modeling

Temperature (C)	11.0	Density(gm/cm3)	1.000
Total Dissolved Salts		mg/kg   mg/l	*not used
Electrical Balancing on		code selects	*not performed
SPECIES	BASIS SWITCH/CONSTRAINT	CONC/ETC	UNITS OR TYPE
redox		0.365	Eh
Na+		13.1508	mg/kg
K+		1.3079	mg/kg
Ca++		116.432	mg/kg
Mg++		51.0742	mg/kg
H+		6.64	pH
HCO3-		329	mg/kg
Cl-		31.22	mg/kg
SO4--		54.27	mg/kg
Mn++		0.0009	mg/kg
H2AsO4-		0.002	mg/kg
Fe++		0.0023	mg/kg
SiO2(aq)		13.6653	mg/kg
Sr++		0.2930	mg/kg

Output data (Arsenic)

Aqueous species accounting for 99% or more of H2AsO4-

Species	Factor	Molality	Per Cent
H2AsO4-	1.00	7.2217E-09	50.89
HAsO4--	1.00	6.9689E-09	49.11
Total			
		1.4191E-08	100.00

Well #197795 , Ottertail Co. depth  
215ft  
T.136 R.44 S.25  
QBAA (Highest As = 91.2 ppb)

Input data for EQ3 modeling

Temperature (C)	8.2	Density(gm/cm3)	1.000
Total Dissolved Salts		mg/kg   mg/l	*not used
Electrical Balancing on		code selects	*not performed
SPECIES	BASIS SWITCH/CONSTRAINT	CONC/ETC	UNITS OR TYPE
redox		-0.025	Eh
Na+		8.62	mg/kg
K+		5.066	mg/kg
Ca++		105.35	mg/kg
Mg++		32.41	mg/kg
H+		6.71	pH
HCO3-		328	mg/kg
Cl-		0.56	mg/kg
SO4--		82.44	mg/kg
Mn++		0.1635	mg/kg
H2AsO4-		0.17156	mg/kg
Fe++		1.7056	mg/kg
SiO2(aq)		14.3158	mg/kg
Sr++		0.5235	mg/kg
Al+++		0.125	mg/kg
Zn++		0.1361	mg/kg

Output data ( Arsenic)

Aqueous species accounting for 99% or more of H2AsO4-

Species	Factor	Molality	Per Cent
HAsO2 (aq)	1.00	4.3317E-07	35.58
As (OH) 3 (aq)	1.00	4.1613E-07	34.19
H3AsO3 (aq)	1.00	3.6626E-07	30.09
<b>Total</b>		<b>1.2173E-06</b>	<b>99.86</b>



# Stability fields for dissolved forms of arsenic as a function of Eh and pH (Quaternary Burried Artesian Aquifer System)

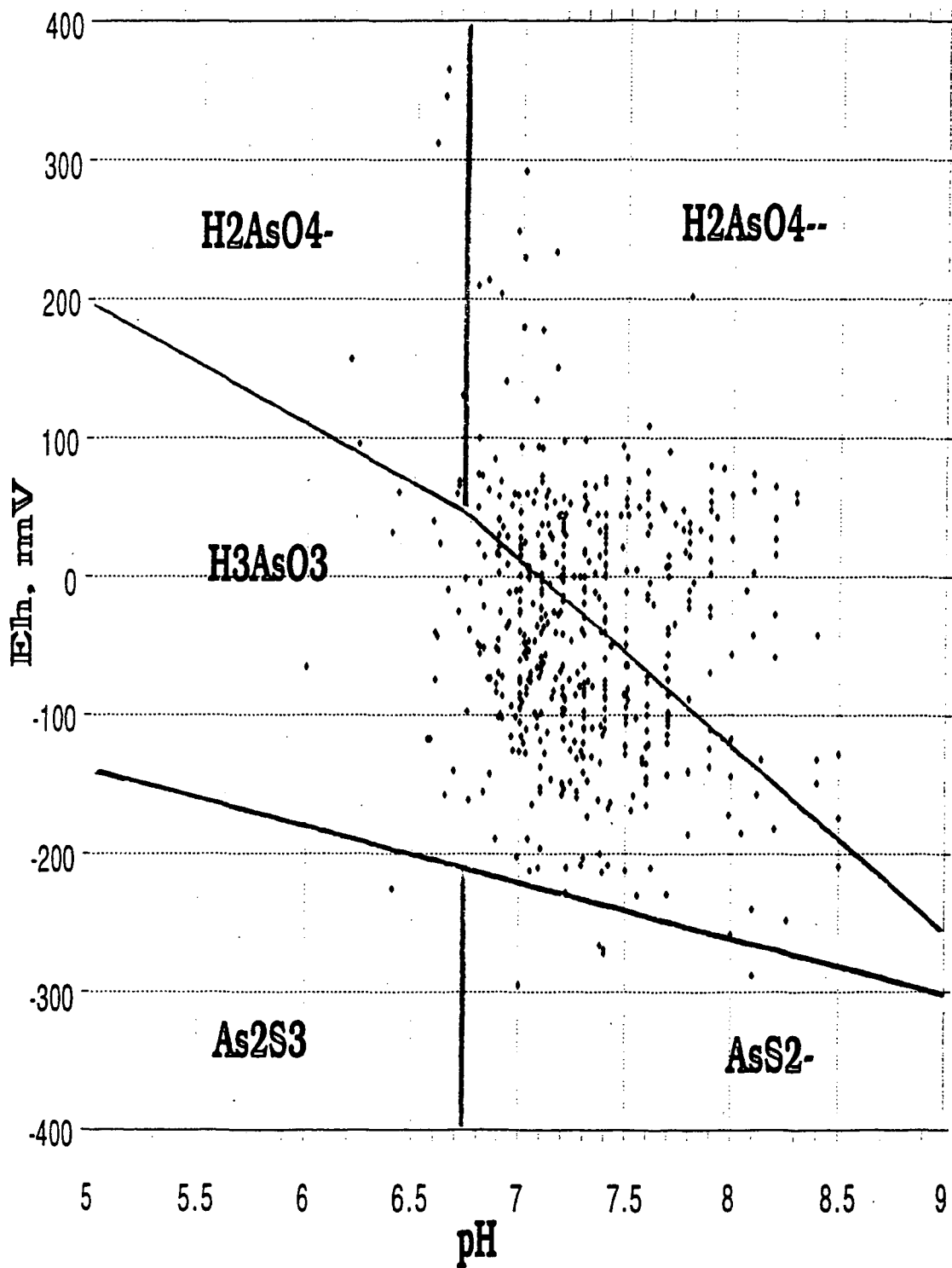

# Stability fields for dissolved forms of arsenic as a function of Eh and pH ( all Hydrogeochemical domains)

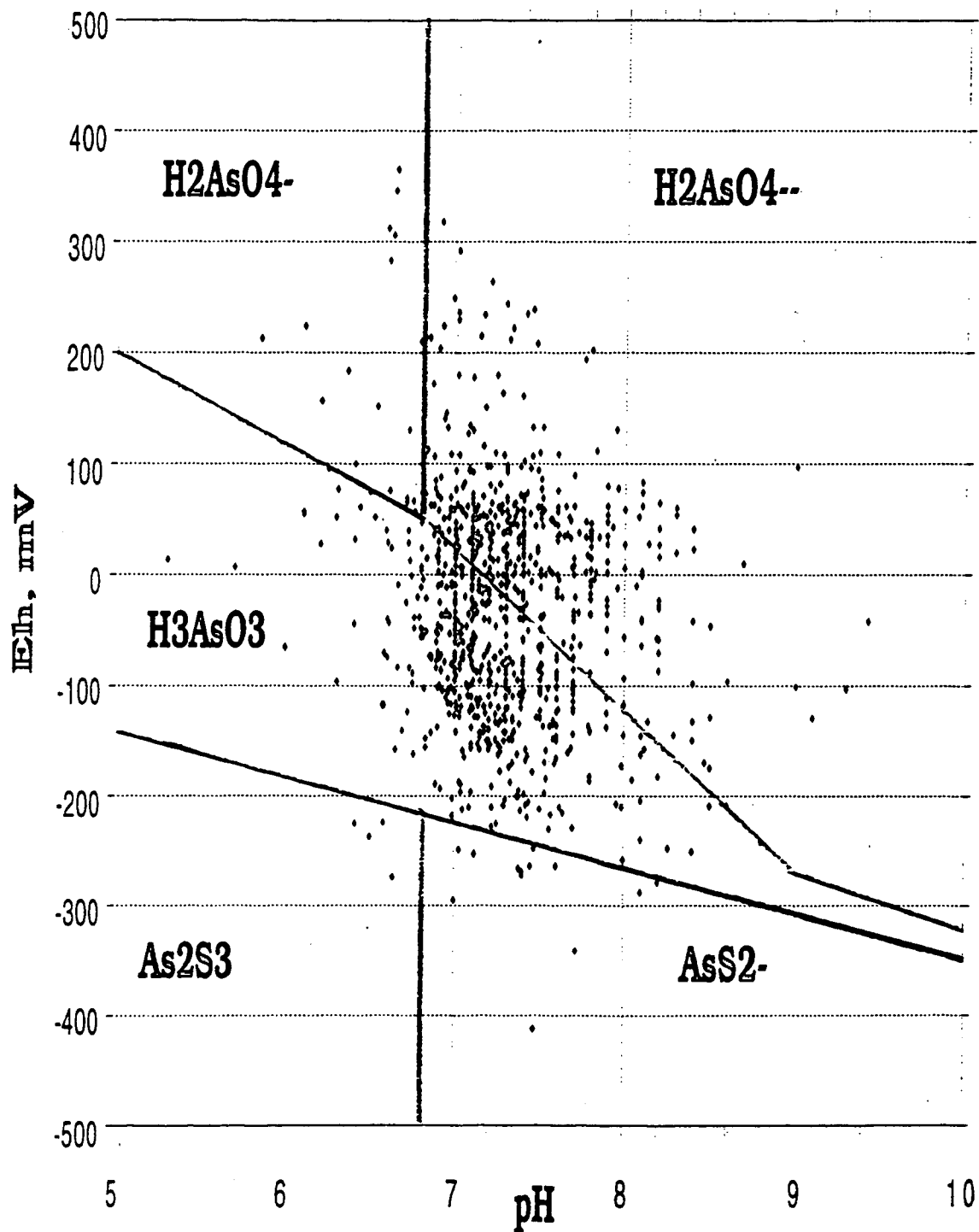

## Arsenic Concentrations in Geologic Materials

Location	Geological unit	Sample type	Range, ppm	Mean, ppm	Reference
Cottonwood Co.	Quaternary	core, rotonomic #1	<5 - 54.0	26	Setterholm, 1995
Murray Co.	Quaternary	core, rotonomic #2	<5 - 33.0	17	Setterholm, 1995
Pipesone Co.	Quaternary	core, rotonomic #3	<5 - 43.0	18	Setterholm, 1995
Rice Co.	Quaternary	core, rotonomic #1	2.5 - 20	7	Hobbs, 1995
Rice Co.	Quaternary	core, rotonomic #2	6.0 - 19.0	11	Hobbs, 1995
Rice Co.	Quaternary	core, rotonomic #3	<5 - 12.0	9	Hobbs, 1995
Stearns Co.	Quaternary	core, rotonomic #3	<2 - 14	4	Meyer, 1995
Stearns Co.	Quaternary	core, rotonomic #5	<2 - 17	4	Meyer, 1995
Lincoln Co	Cretaceous	core	1.0 - 70.0	7	Setterholm, 1997
Yellow Medicine Co.	Cretaceous	core	4.0 - 7.0	5	Setterholm, 1997
Lac Qui Parle Co.	Cretaceous	core	3.0 - 44.0	22	Setterholm, 1997
Lyon Co.	Cretaceous	cuttings	1.0 - 9.0	7	Setterholm, 1997
Thief R. Falls Quad.	Quaternary	stream sediments	0.0 - 56.0	2.7	NURE, 1981
Watertown Quad.	Quaternary	stream sediments	0.5 - 13.2	3.6	NURE, 1981 a
New Ulm Quad.	Quaternary	stream sediments	0.1 - 20.6	3.6	NURE, 1979
St. Cloud Quad.	Quaternary	stream sediments	0.1 - 9.2	2.6	NURE, 1979 a
Millbank Quad.	Quaternary	stream sediments	0.1 - 22.7	3	NURE, 1981 b
Grand Forks Quad.	Quaternary	stream sediments	0.1 - 10.0	2	NURE, 1981 c
Fargo Quad.	Quaternary	stream sediments	0.3 - 20.0	2.7	NURE, 1981 d

## **FURTHER RESEARCH NEEDS:**

- **Establish sampling program to map spatial and temporal variability**
- **Design a flow-tube to address in detail the geological, geochemical, hydrogeological and hydrochemical framework of high concentration of arsenic**
- **Experimental measurements of sediments and fluids to verify adsorption model**

**Modeling Fate and Transport of Petroleum  
Constituents in Vadose and Saturated Zones  
Using SESOIL and AT123D**

**Vladimir M. Prilepin**  
Tetra Tech EM, Inc.

July 8 - 9, 1997

**JOINT RUSSIAN-AMERICAN HYDROGEOLOGY SEMINAR**

Russian - American Center for Contaminants Transport Studies  
Ernest Orlando Lawrence Berkeley National Laboratory  
Berkeley, California 94720

**Modeling Fate and Transport of  
Petroleum Constituents in  
Vadose and Saturated Zones  
Using SESOIL and AT123D**

Vladimir M. Prilepin  
Tetra Tech EM, Inc.

# FATE OF ORGANIC CHEMICALS (OC) (WEBBER & MILLER 1989)

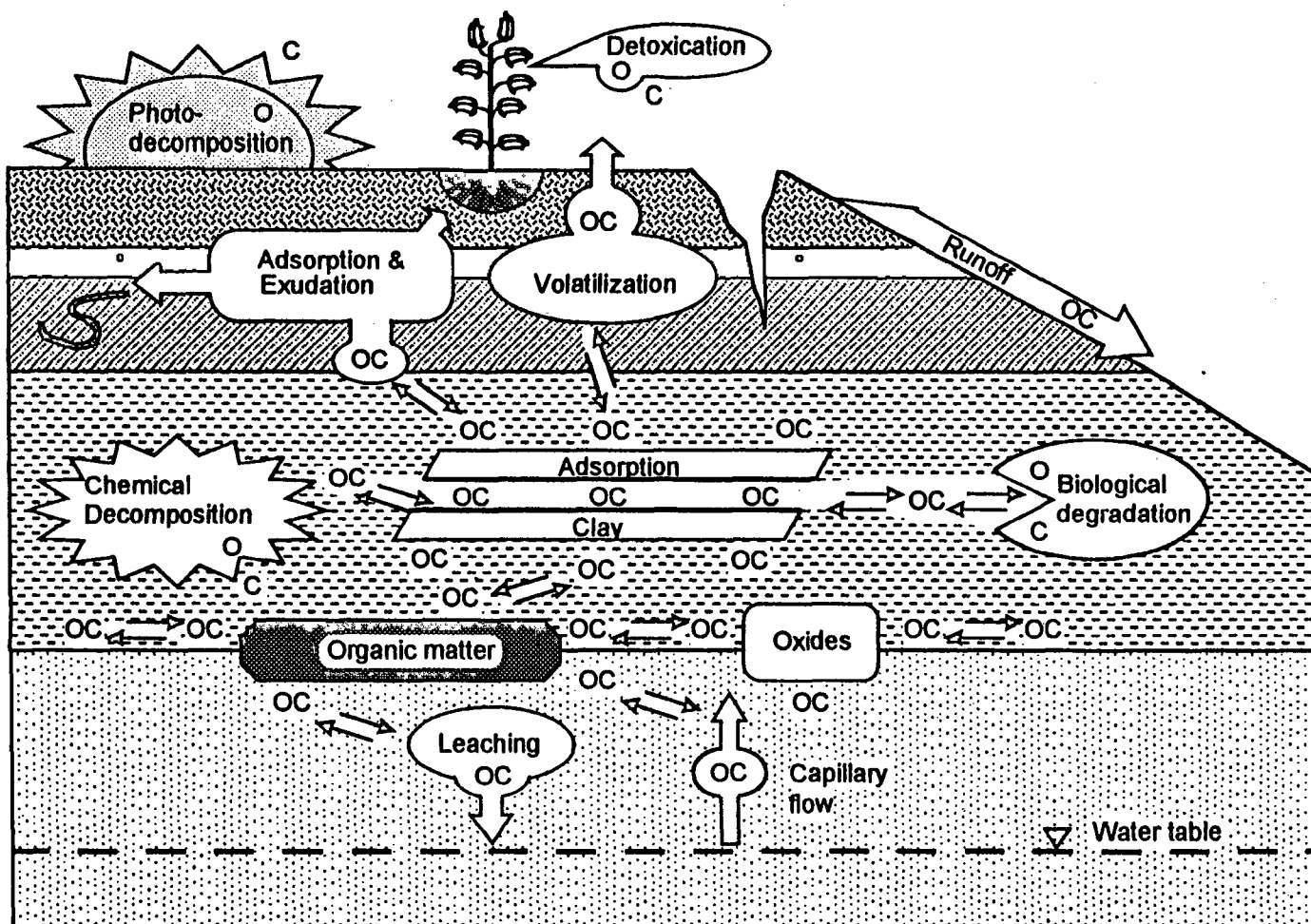

## What is SESOIL?

- Semi-analytical chemical transport and fate model
- Simulates water movement, sediment transport, and pollutant transport and fate in the unsaturated zone
  - Assumes chemical equilibrium
  - Can estimate leaching of contaminants to groundwater and transfer of volatile compounds to the atmosphere
- Includes a variety of options for mass loading and to address heterogeneity

## SESOIL Model

- SESOIL stands for **Seasonal *Soil*** compartment model
- Developed by Marcos Bounazountas and Janet Wagner of Arthur D. Little, Inc., for U.S. EPA's Office of Toxic Substances (1981)
- Extensively modified by David Hetrick at Oak Ridge National Laboratory (1986)
- Designed to predict the long-term transport and fate of chemicals in unsaturated soil



## SESOIL Compartment

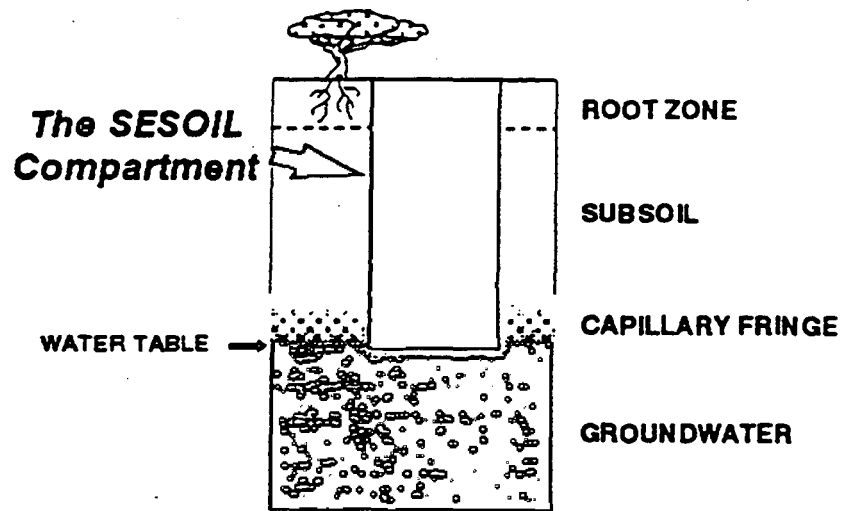

## Hydrologic Cycle

- Based on the unsaturated zone water balance model of Eagleson (1978)
  - *Climate, Soil and Vegetation, Water Resources Research*, v. 14, no. 3, p. 705-776
- Statistical dynamic formulation of a vertical water balance
  - Statistical model generates storm events

# HYDROLOGIC CYCLE SCHEMATIC

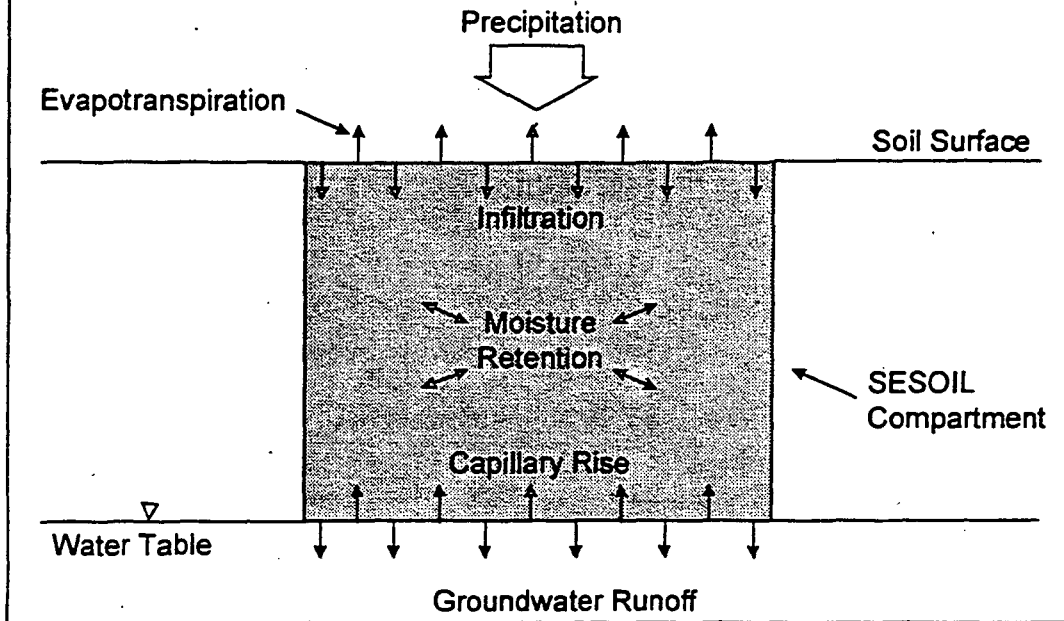

## SESOIL Hydrologic Cycle Assumptions

- Soil column is homogeneous and isotropic
  - Effective porosity and permeability are uniform
- Soil water flow is one-dimensional vertical
- Uniform soil moisture content for the entire soil column at "long-term" average value
- Precipitation
  - Storm series is represented by Poisson arrivals of rectangular gamma-distributed intensity pulses

# SCHEMATIC OF CHEMICAL PHASES

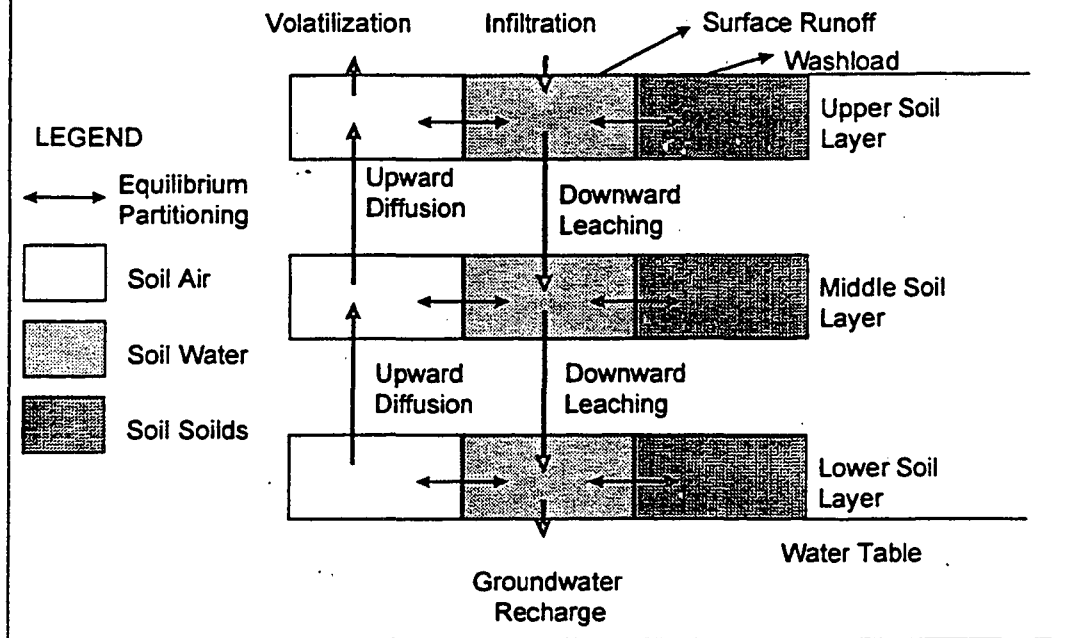

## Pollutant Depth Algorithm

- Determines the depth that the contaminant has reached in the soil column
- Accounts for advective velocity of soil water and retardation
- Contaminant mass is not released downward from a sublayer until the pollutant depth reaches the bottom of that sublayer

## Groundwater Mixing Zone

- Simple dilution factor (volumetric mixing)
  - Based on Summers model
  - Contaminant mass in groundwater recharge mixes with flowing groundwater in a control volume (mixing zone)
- Combines contaminant mass balance and water balance for the mixing zone
- Assumes contaminant mass is uniformly mixed in the control volume
  - Yields average groundwater concentration in the mixing zone

## The Linkage Between SESOIL and AT123D Models

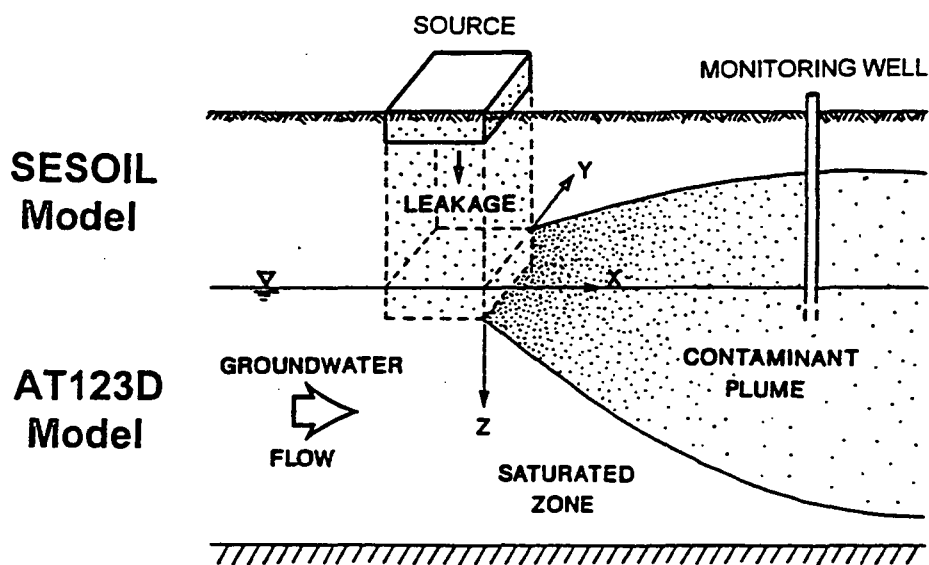

## AT123D Model

- AT123D stands for *Analytical Transient 1-,2-, and 3- Dimensional* model
- Developed by George Yeh at Oak Ridge National Laboratory for DOE and U.S. EPA's Office of Toxic Substances (1981)
- Designed to predict the transport and fate of chemicals, radionuclides, and heat in groundwater for simple aquifer systems
- Handles a variety of source configurations and release rates

## AT123D Assumptions

- Aquifer is homogeneous
  - Porosity and permeability are uniform
- Groundwater flow is 1-dimensional horizontal
  - Hydraulic gradient no more than a few percent
- Advective velocity determined by Darcy's law
- Groundwater flow is at steady-state
- Anisotropy is handled by varying the dispersivity
- Retardation is uniform throughout the aquifer

## AT123D Transport and Fate Processes

- Advection
- Hydrodynamic dispersion
  - Mechanical dispersion
  - Molecular diffusion
- Retardation
- First-order decay
  - Single decay term

## Governing Equation

$$\frac{\partial C}{\partial t} = \nabla \cdot \left( \frac{D}{R} \cdot \nabla C \right) - \nabla \cdot \frac{v}{R} C + \frac{\dot{M}}{n_e R} - \lambda C$$

$C$	=	solute concentration (mg/L)
$D$	=	dispersion tensor (m <sup>2</sup> /hr)
$R$	=	retardation factor (unitless)
$v$	=	average linear velocity (m/hr)
$M$	=	mass loading (kg/hr)
$n_e$	=	effective porosity (m <sup>3</sup> /m <sup>3</sup> )
$\lambda$	=	first-order decay constant (1/hr)

# Conceptual Model of Contaminant Fate and Transport in the Subsurface

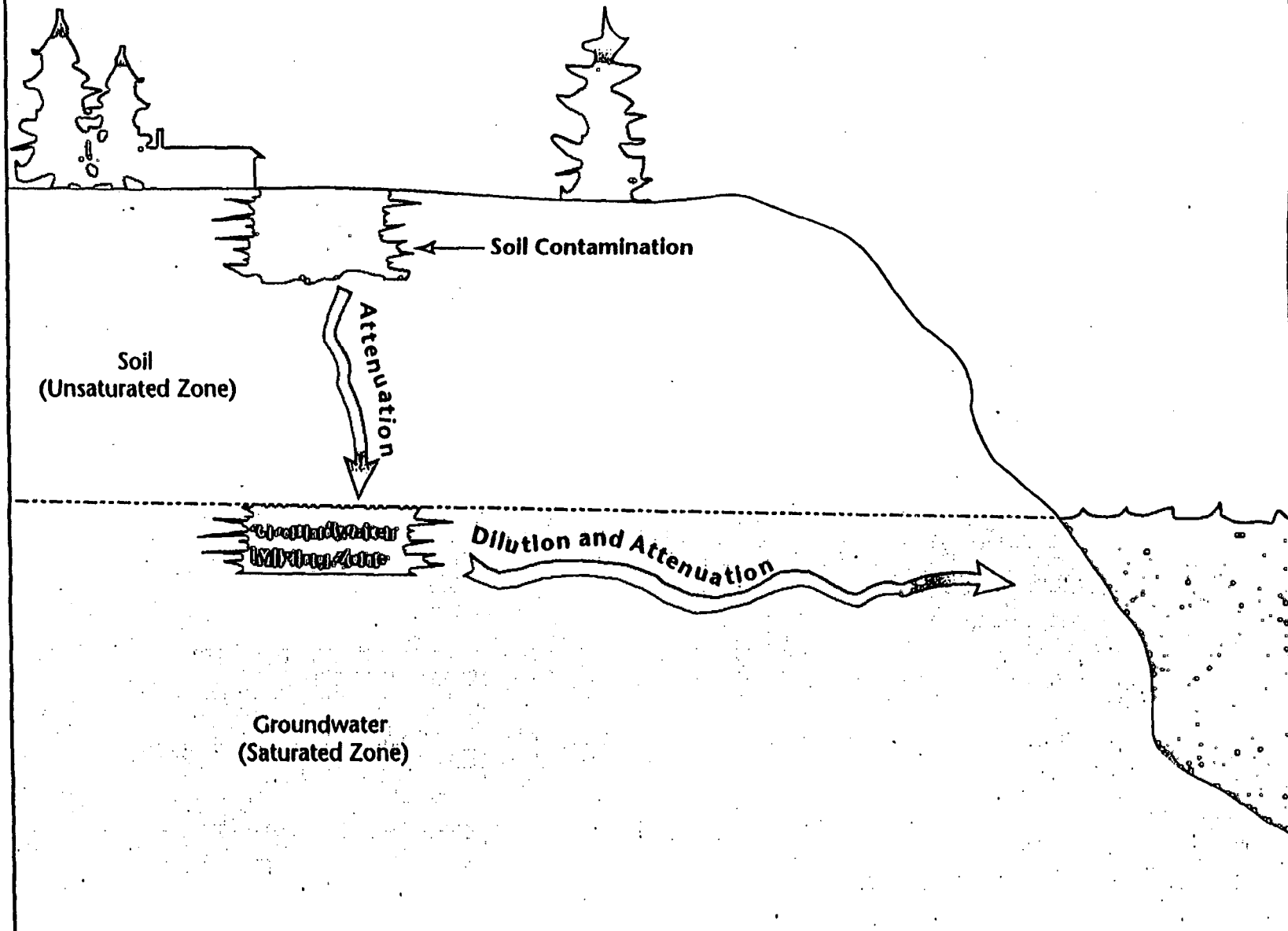

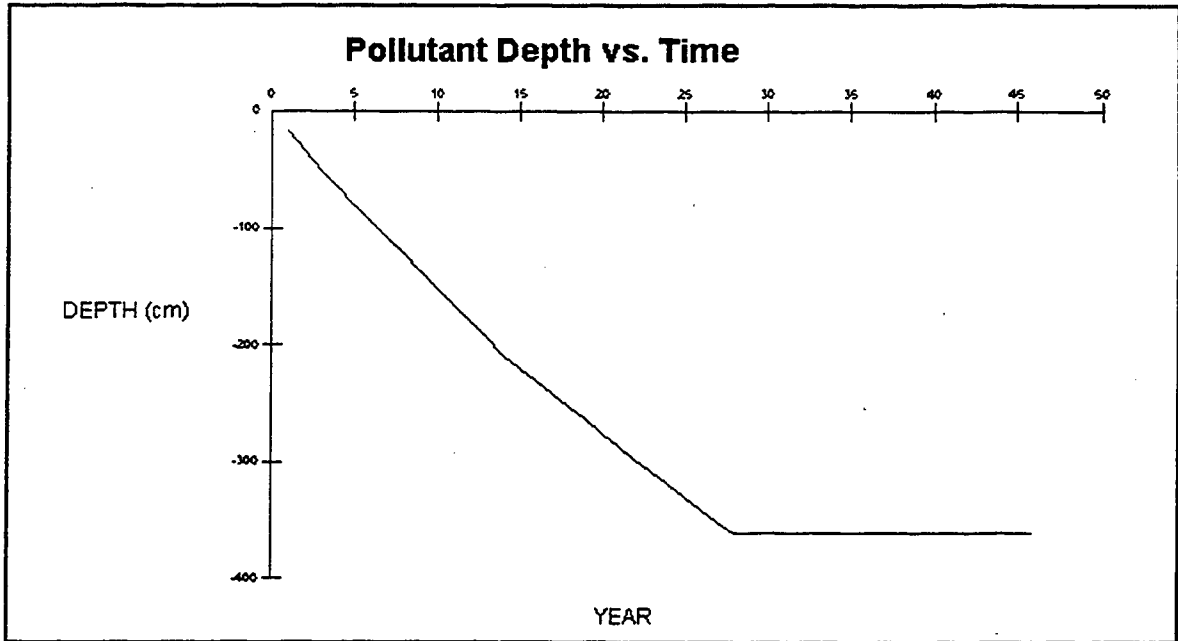

**SESOIL RESULTS  
PREDICTED MIGRATION RATE OF BENZENE FROM  
THE VADOSE ZONE SOILS TO GROUNDWATER**

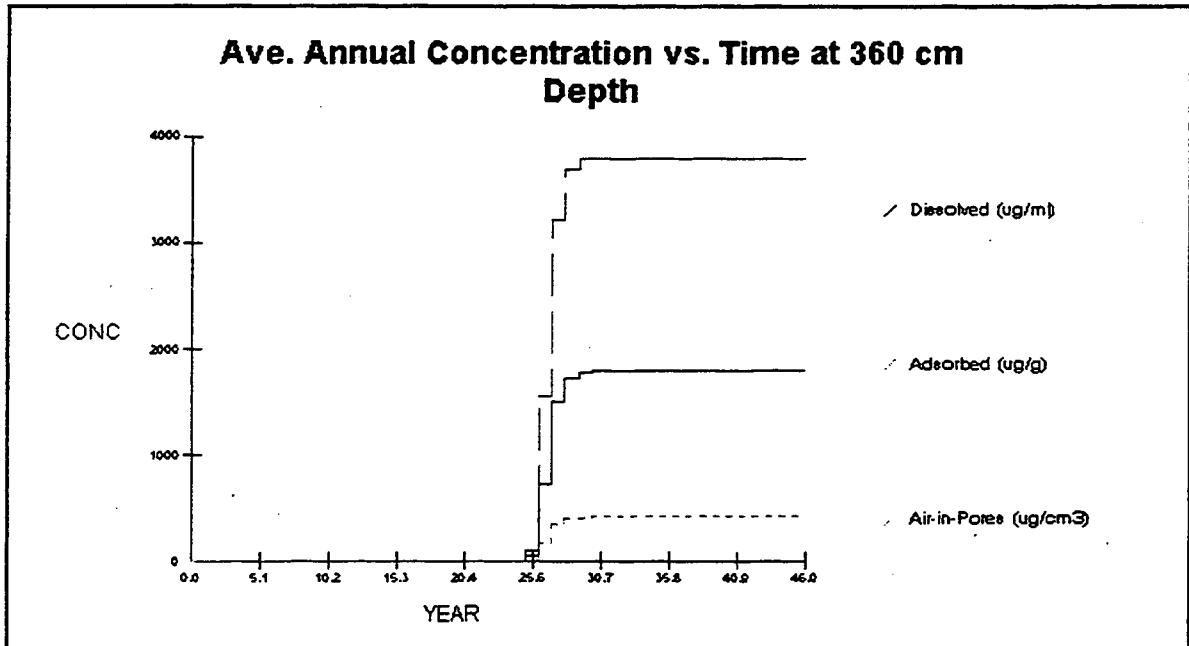

**SESOIL RESULTS (Continued)  
PREDICTED LEACHATE CONCENTRATION OF BENZENE AT THE WATER TABLE.**



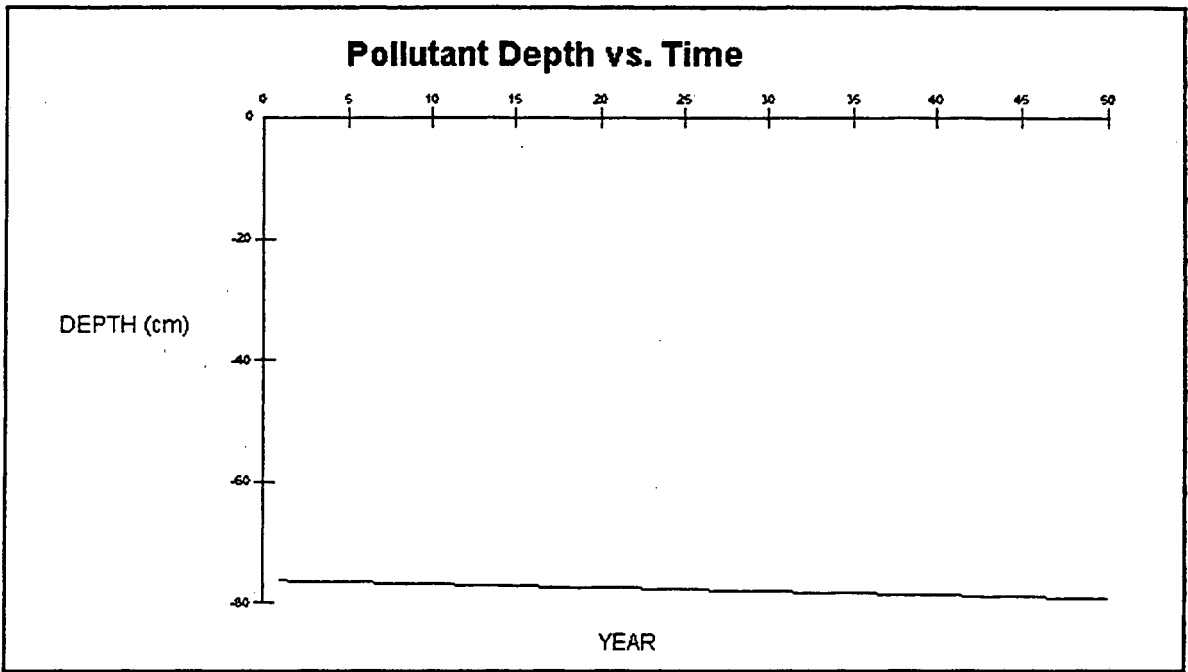

Note: Dissolved phenanthrene migrated less than 2 inches for 60 years.

**SESOIL RESULTS**  
**PREDICTED MIGRATION RATE OF DISSOLVED PHENANTHRENE**  
**IN THE VADOSE ZONE SOILS.**

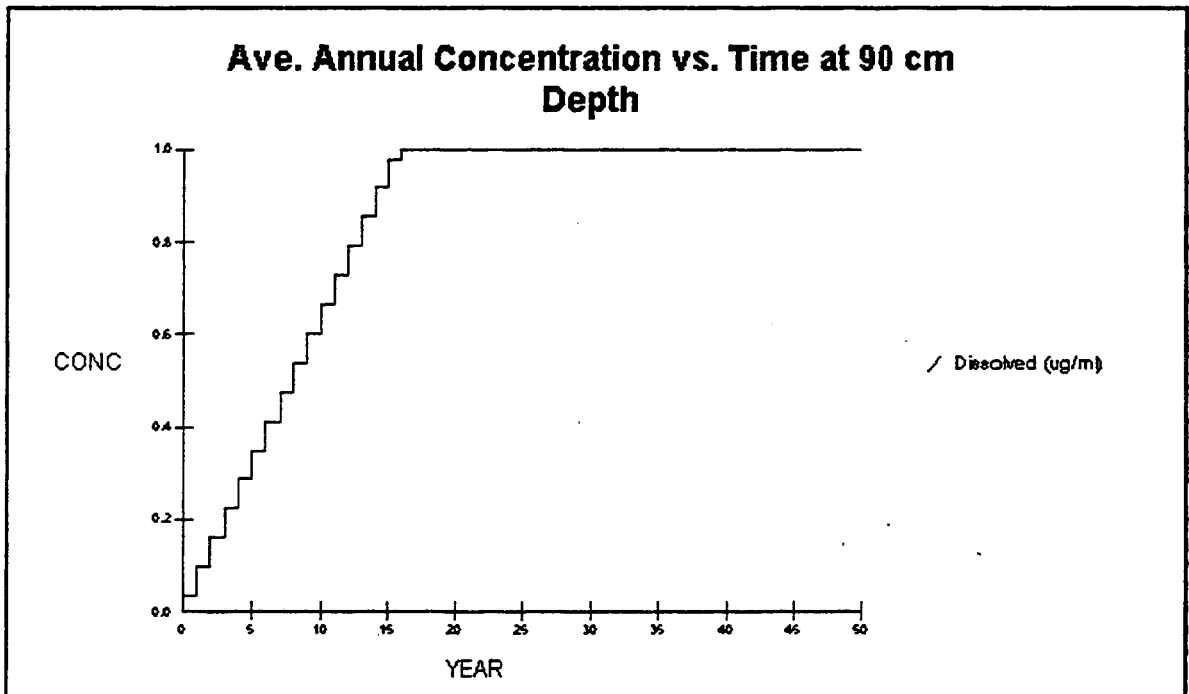

**SESOIL RESULTS (Continued)**  
**PREDICTED LEACHATE CONCENTRATION OF PHENANTHRENE**  
**AT THE MIDDLE OF CONTAMINATED SOIL LAYER.**

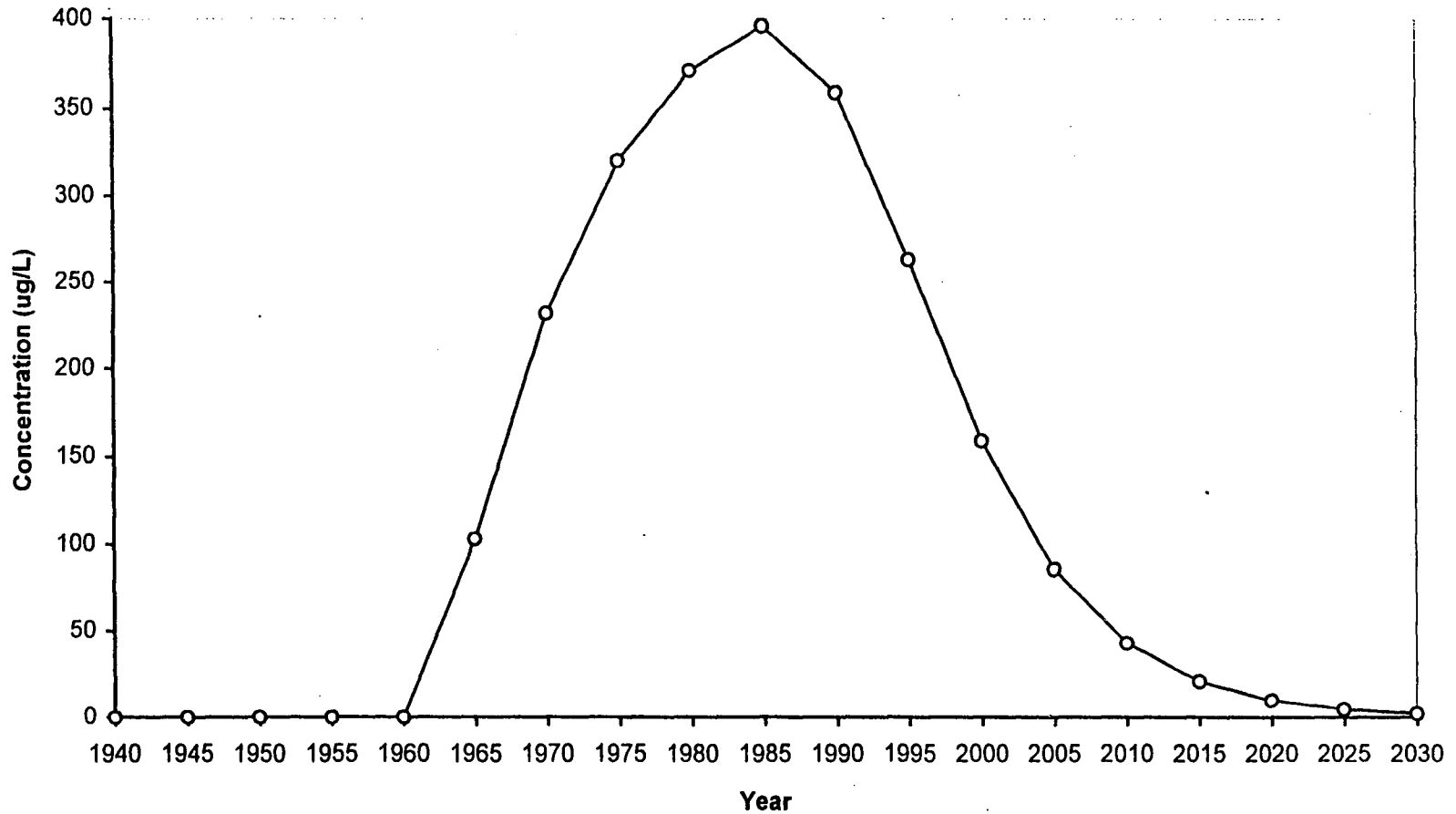

Note: AT123D simulation is based on a time-varying release (1935 - 1985) predicted by SESOIL (an area source of 225 square meters at soil sample location 11-F upgradient from well 11-MW05).

**SESOIL AND AT123D LINKAGE  
SIMULATED BENZENE CONCENTRATIONS IN GROUNDWATER AT THE SOURCE**

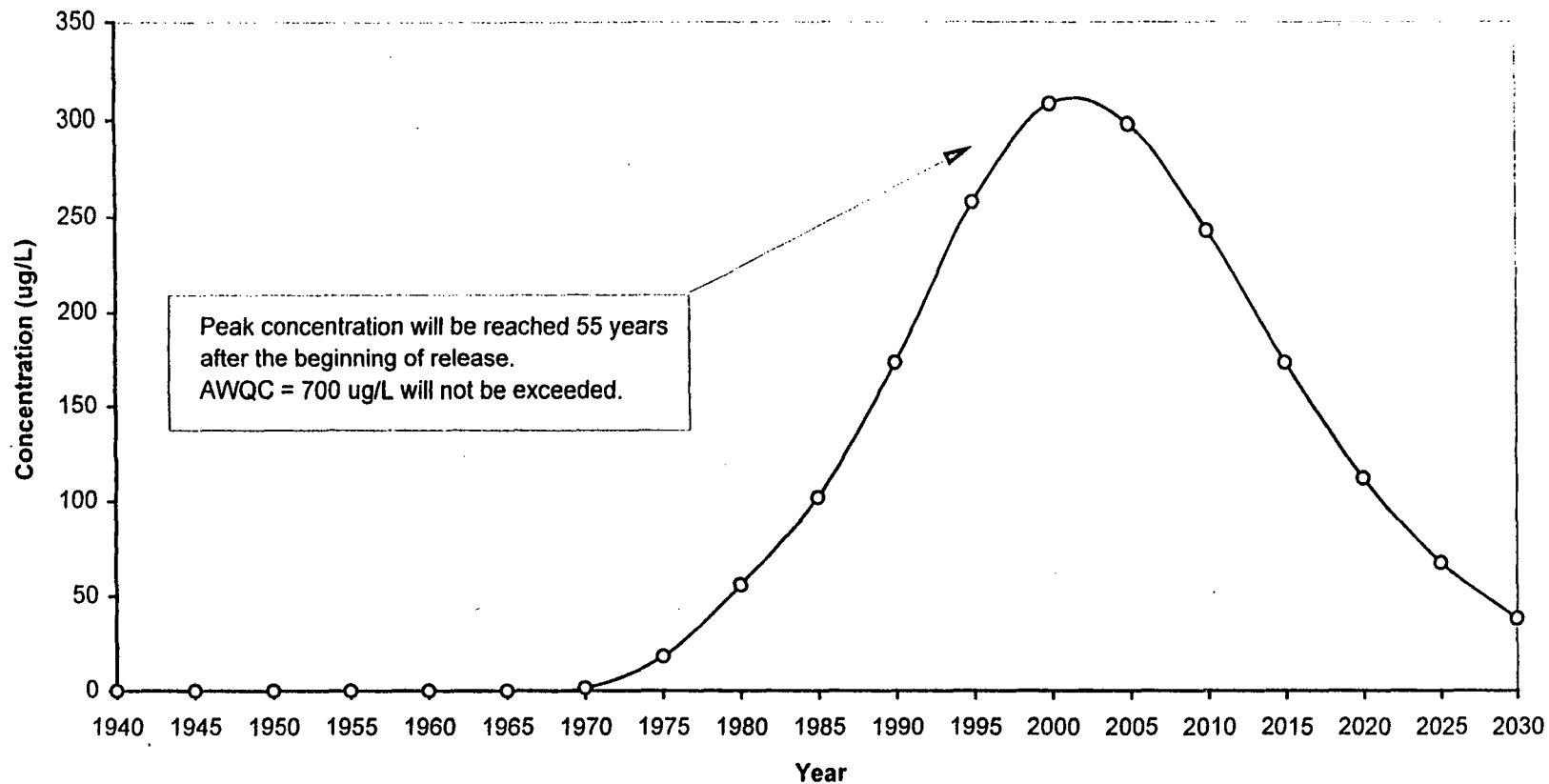

Note: AT123D simulation is based on a time-varying release (1935 - 1985) predicted by SESOIL (an area source of 225 square meters at soil sample location 11-F upgradient from well 11-MW05 which is located 14 meters upgradient from the shoreline).

**SESOIL AND AT123D LINKAGE (Continued)**  
**PREDICTED BENZENE CONCENTRATIONS IN GROUNDWATER AT THE SHORELINE.**

## **CONCLUSIONS**

- SESOIL and AT123D are effective tools for a “first cut” fate and transport simulations
- Petroleum mixtures may be modeled using representative constituents, because both models allow simulations of only one chemical at a time
- Biodegradation rate, soil - water partitioning, climate, effective solubility (SESOIL), hydraulic gradient, and hydraulic conductivity (AT123D) are highly sensitive variables

**Contaminant Hydrogeology of Radionuclides at  
Lawrence Livermore National Laboratory  
Site 300**

**Michael J. Taffet**  
Environmental Restoration Division  
Lawrence Livermore National Laboratory

July 8 - 9, 1997

**JOINT RUSSIAN-AMERICAN HYDROGEOLOGY SEMINAR**

Russian - American Center for Contaminants Transport Studies  
Ernest Orlando Lawrence Berkeley National Laboratory  
Berkeley, California 94720

---

---

**Contaminant Hydrogeology of Radionuclides  
at Lawrence Livermore National Laboratory Site 300**

---

---



**presented to**

**Joint Russian-American Hydrogeology Seminar**

**July 8, 1997**

**E.O. Lawrence Berkeley National Laboratory – Berkeley, California**

**Michael J. Taffet**

Environmental Restoration Division

Lawrence Livermore National Laboratory

(510) 422 6114 – taffet1@llnl.gov

Work performed under the auspices of the U.S. Department of Energy by  
Lawrence Livermore National Laboratory under Contract W-7405-Eng-48.

# Generalized Geologic Map of the San Francisco Bay Area

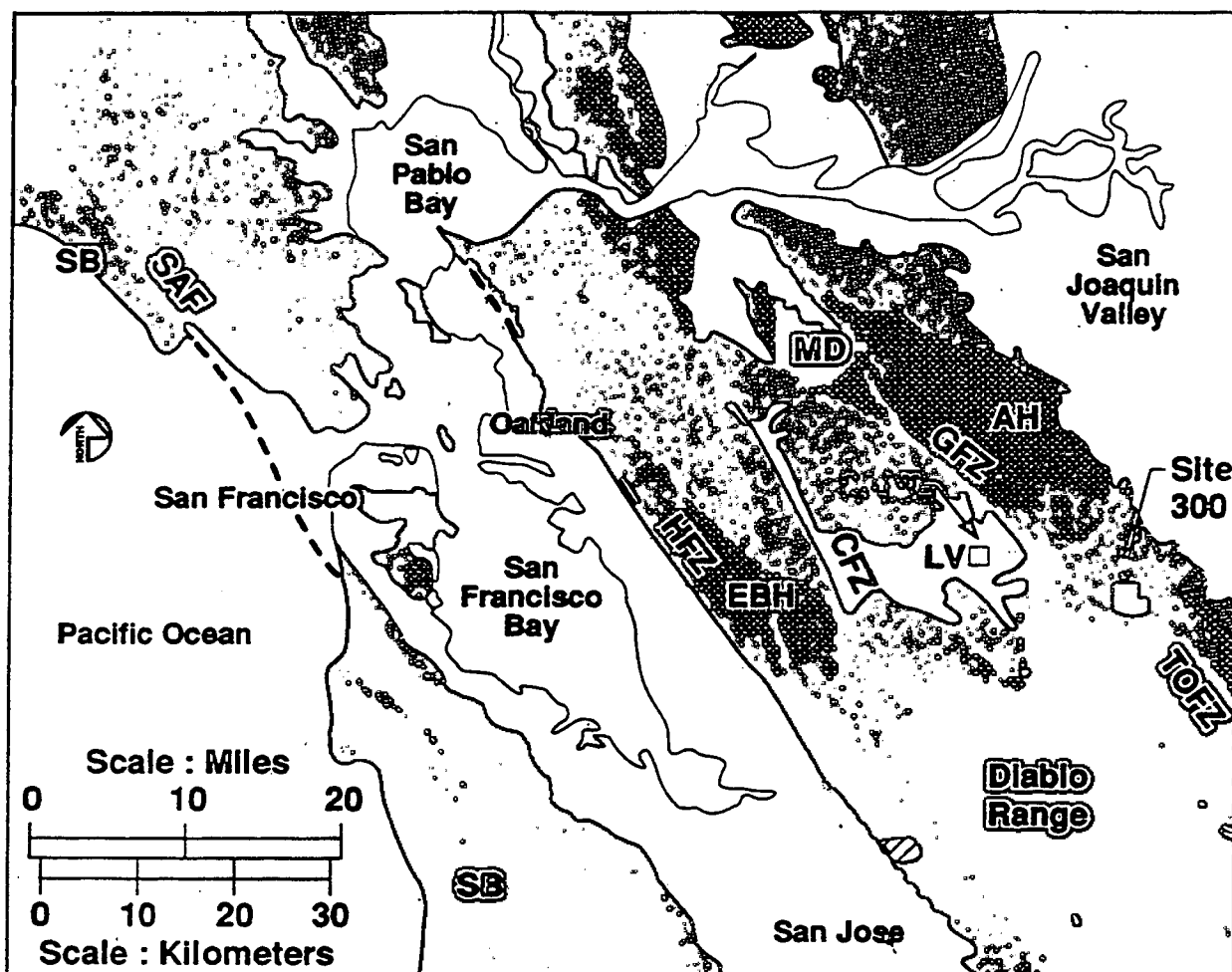

## Key to symbols

- SB-Salinian Block
- SAF-San Andreas fault
- HFZ-Hayward fault zone
- EBH-East Bay Hills
- CFZ-Calaveras fault zone
- MD-Mount Diablo
- GFZ-Greenville fault zone
- AH-Altamont Hills
- TOFZ-Tesla-Ortogonalita fault zone
- LV-Livermore-Amador Valley



## Late Tertiary-Quaternary

-  Alluvium and continental sediments

## Tertiary

-  Sediments and volcanics (locally non-marine) including Plio-Pleistocene

## Jurassic-Cretaceous

-  Great Valley Sequence
-  Franciscan Complex
-  Mesozoic Granite

Adapted from Raber and Carpenter, 1983  
8/13/90

# Extent of ground water contamination at LLNL Site 300

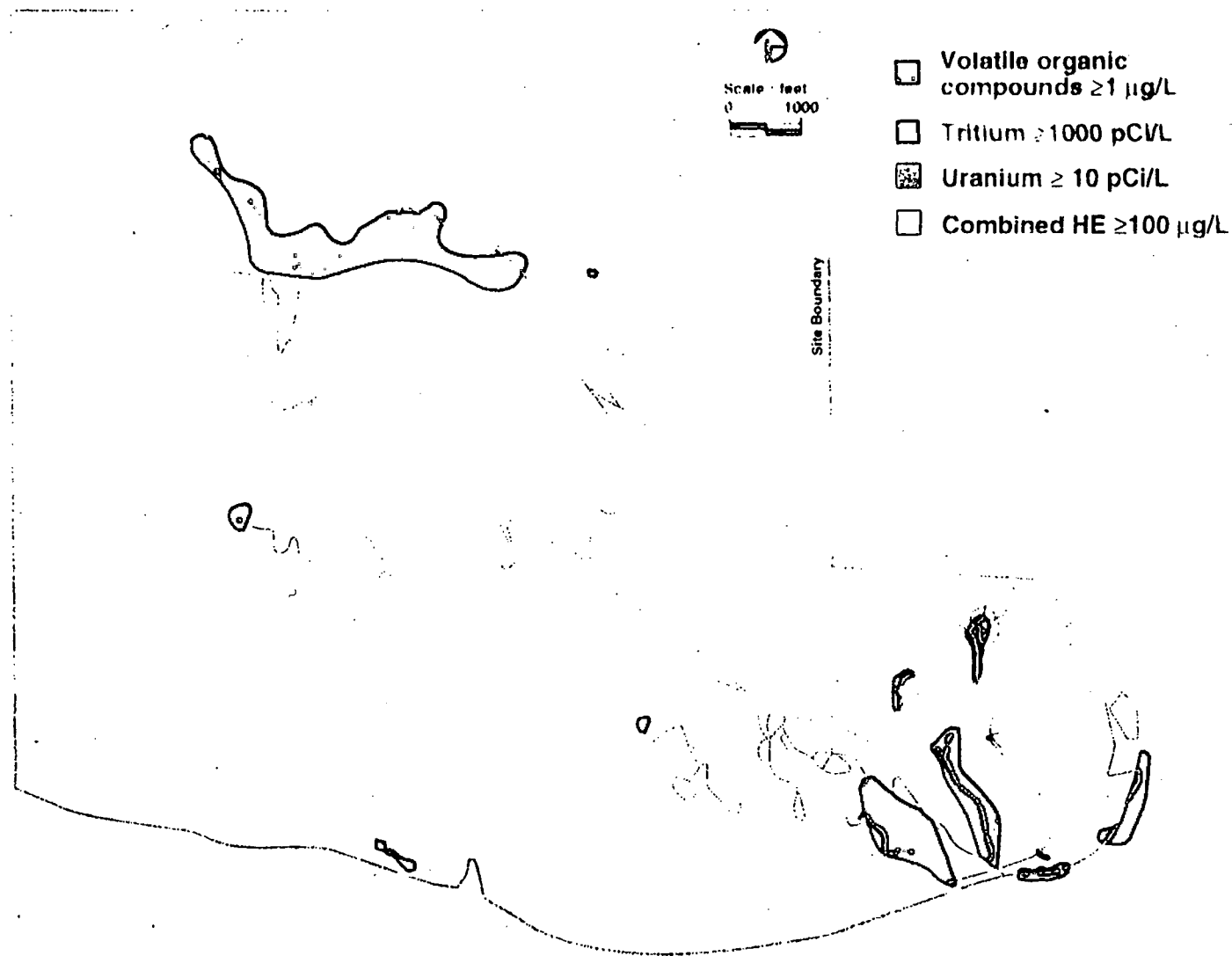

250



# Conceptual hydrogeologic model for the East and West Firing Area study area

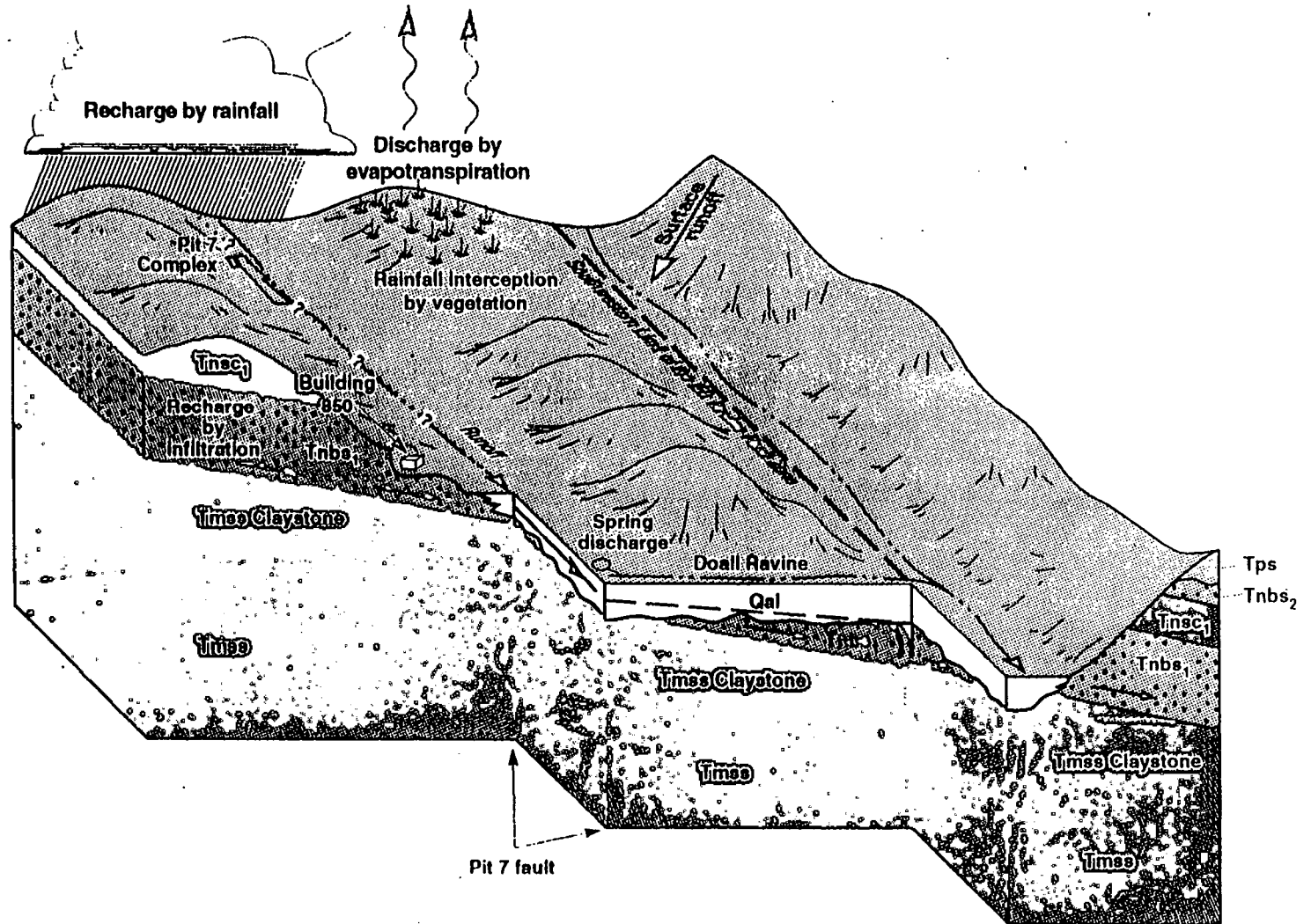

# LOCATIONS OF MONITORING INSTALLATIONS, MAJOR BUILDINGS, AND ROADS IN THE WFA AND EFA

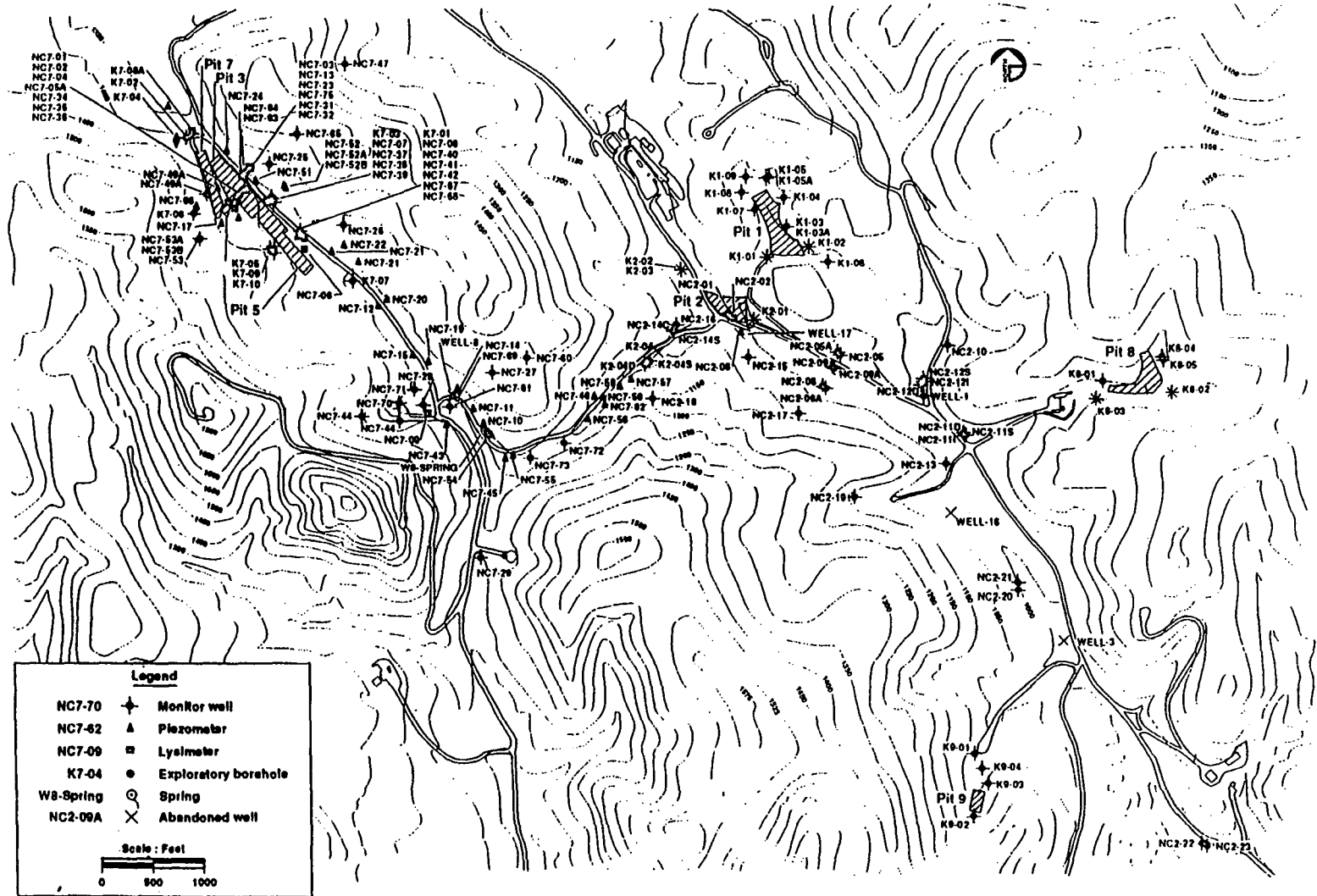

252

# Geologic map of the Building 850 study area

253

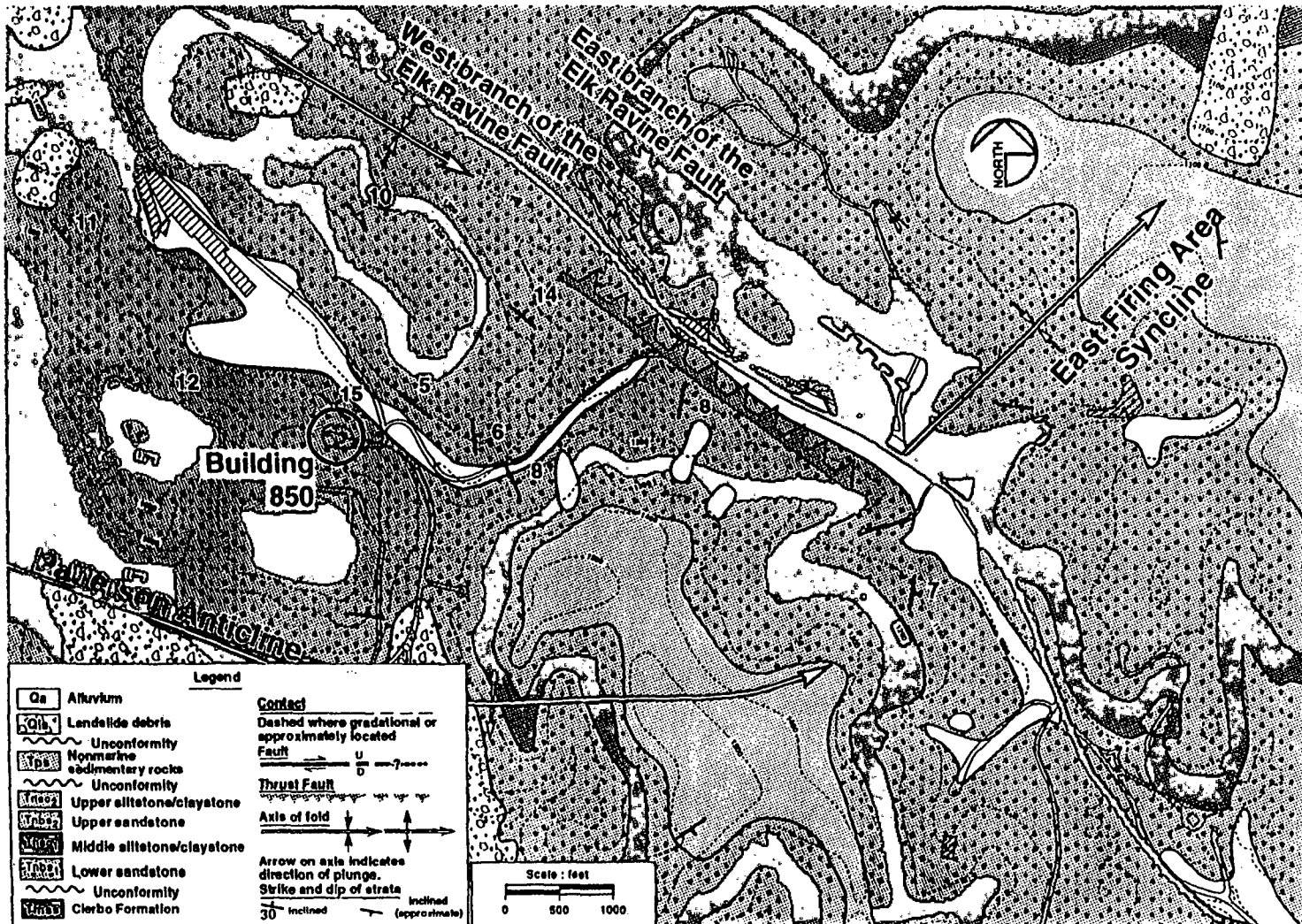

# Water elevation contours, first water-bearing zone, WFA/EFA, May 1991

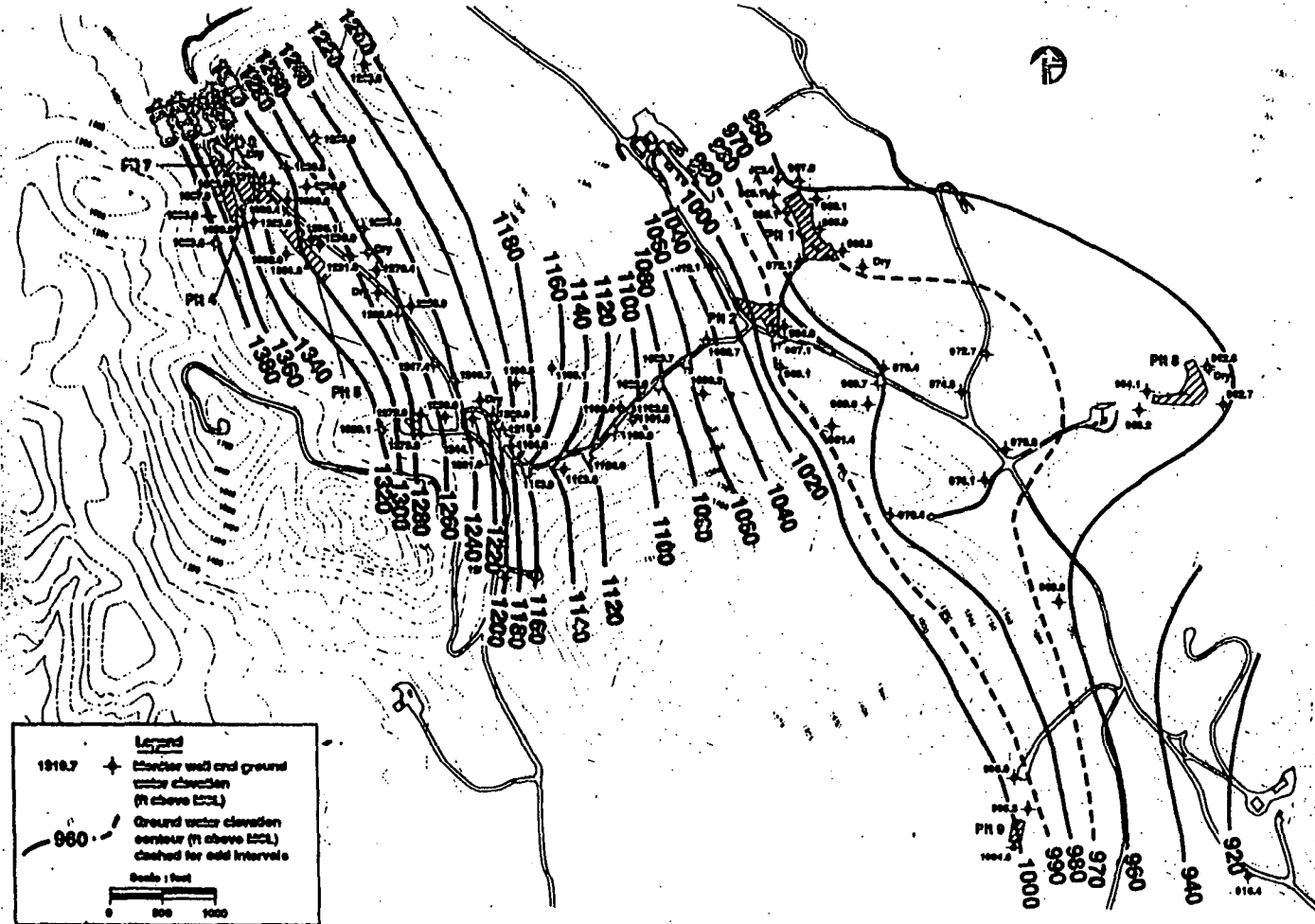

# Geologic cross-section

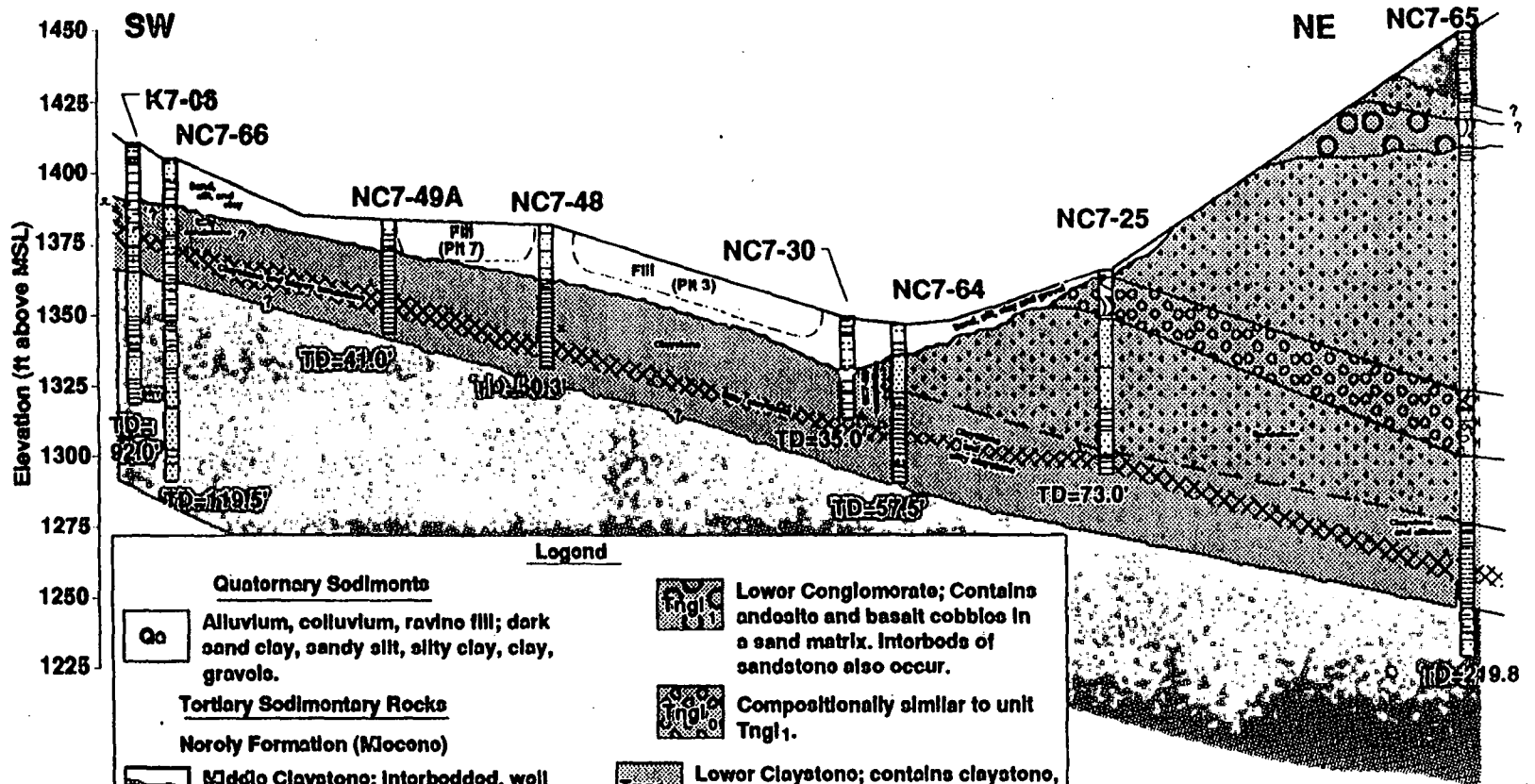

### Legend

Quaternary Sediments	
<b>Qo</b>	Alluvium, colluvium, ravine fill; dark sand clay, sandy silt, silty clay, clay, gravels.
Tertiary Sedimentary Rocks	
Noroly Formation (Miocene)	
<b>Tnc1</b>	Middle Claystone; interbedded, well lithified silty claystone, siltstone and silty sandstone.
<b>Tnba</b>	Lower Blue Sandstone Member; massive blue sandstone with interbeds of calcareous claystone, siltstone and tuff. Two conglomerate units occur within this member.
<b>Tng1</b>	Lower Conglomerate; Contains andesite and basalt cobbles in a sand matrix. Interbeds of sandstone also occur.
<b>Tng0</b>	Compositionally similar to unit Tng1.
Clerbo Formation (Miocene)	
<b>Tnc0</b>	Lower Claystone; contains claystone, siltstone and clayey tuff with minor sandstone interbeds.
<b>Tms0</b>	Interbedded micaceous, pyritic sandstone and claystone with minor siltstone.
	Shallow water-bearing zone

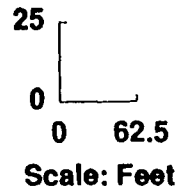

2.5: 1 Vertical exaggeration

255

# Tritium

---



- **“Di-neutronated” hydrogen**
- **Half-life of 12.3 y, decays to stable He**
- **Weak beta emitter**
- **Ideally conservative tracer (HTO)**
- **Used 20,000 Ci at B850 (1963-78)**
- **Background activities in rain water are 200-300 pCi/L**

# Isopleth map of ground water tritium activity (pCi/L) for the first water-bearing zone, EFA/WFA, April 1995

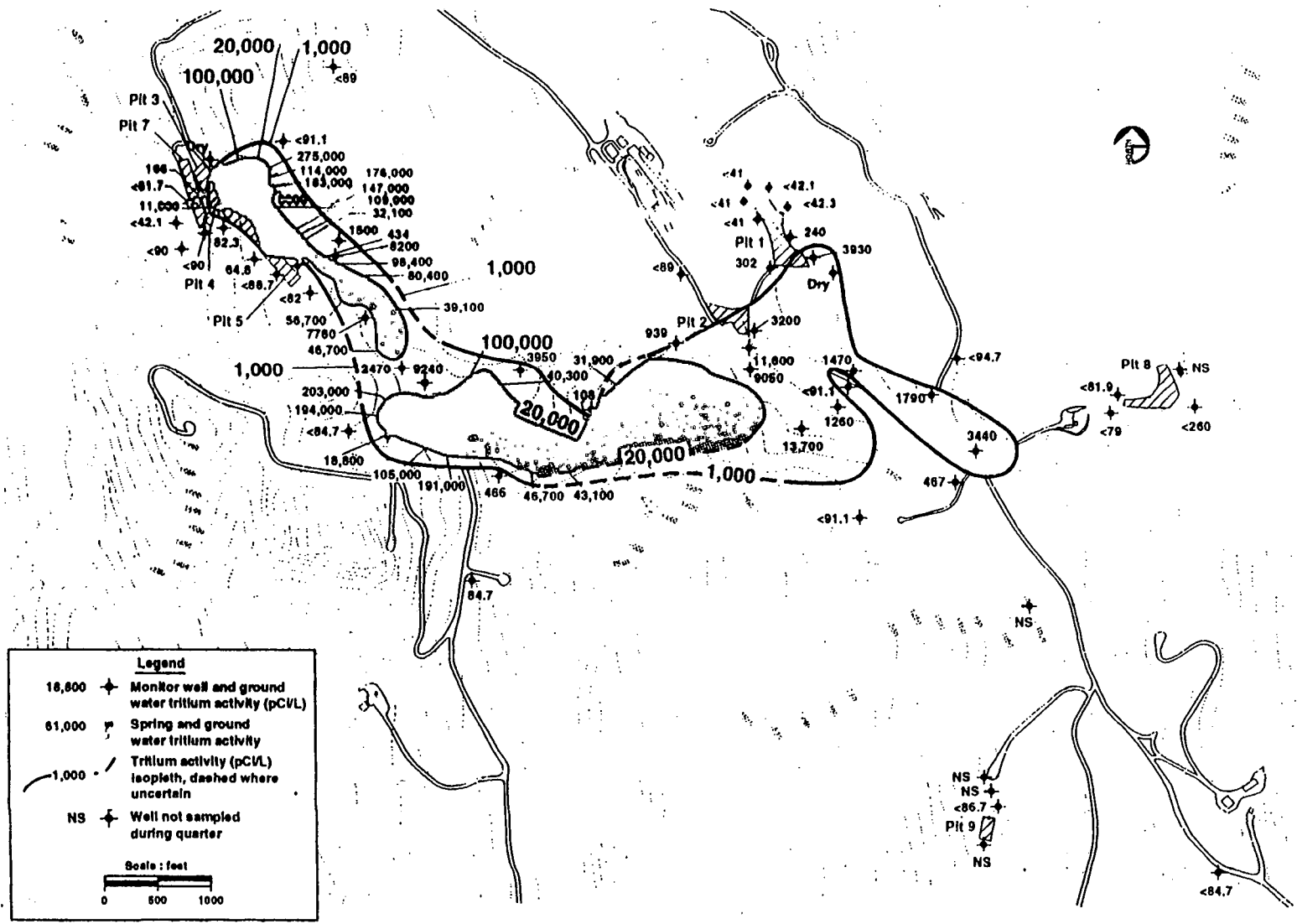

257

# Soil core tritium downgradient of Pit 3



One  $\mu\text{Cl/L} = 10^6 \text{ pCl/L}$

NE  $\rightarrow$

NC7-25

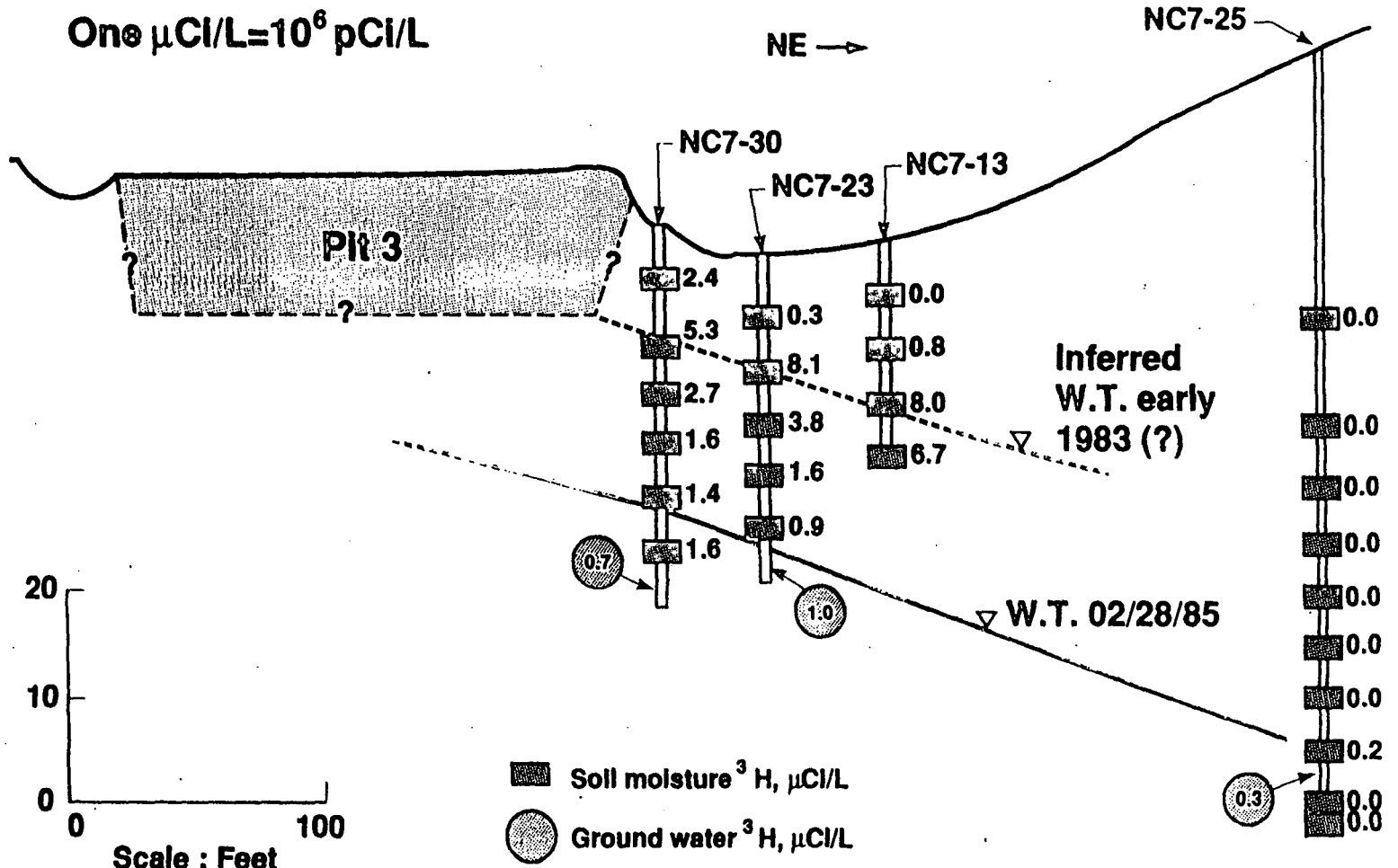

258



# K7-03 GWE, Tritium

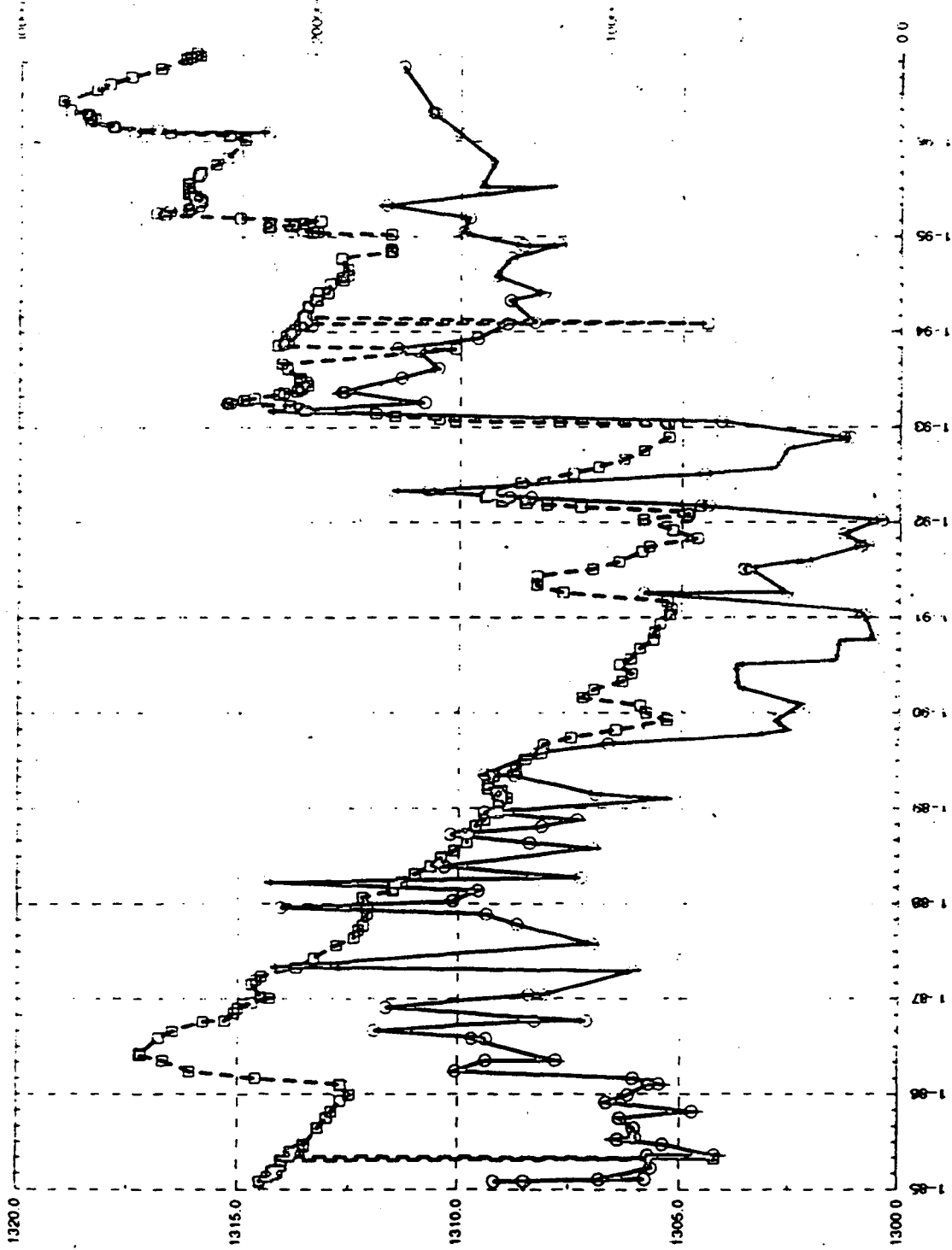

---□ K7-03@Qal-Tmss(ft MSL)GWE      —● K7-03@Qal-Tmss(pCi/L) Tritium

# Topographic map of the Building 850 area



260

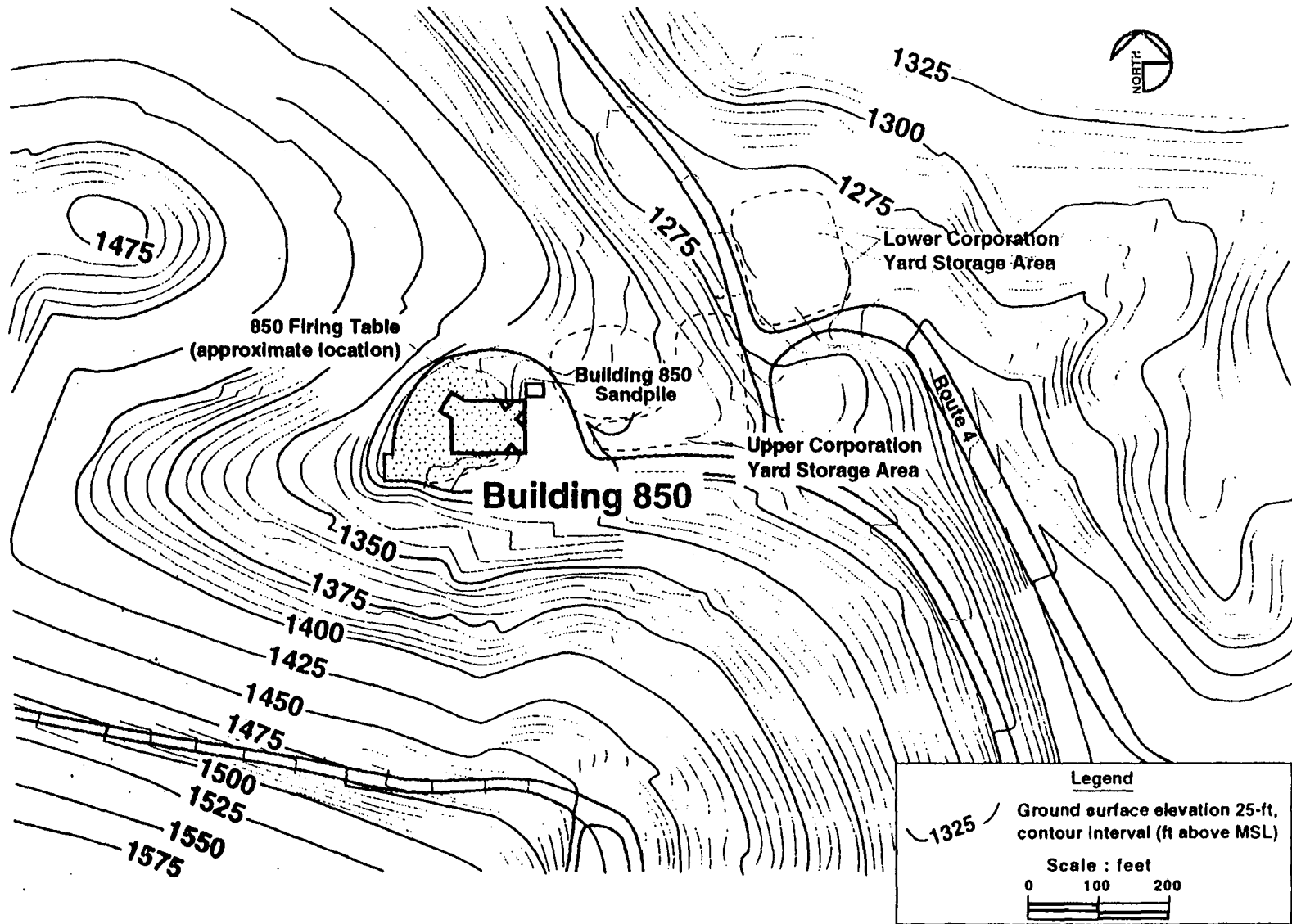

**Legend**

1325 Ground surface elevation 25-ft, contour interval (ft above MSL)

Scale : feet

0 100 200

## Uranium geochemistry

---



- Uranium is mobile in oxygenated, bicarbonate dominant waters at pH > 6 and forms carbonate complexes
- $^{234}\text{U}$  is preferentially leached from rocks
- $a_{234\text{U}}/a_{238\text{U}} > 1$  for natural waters
- $a_{234\text{U}}/a_{238\text{U}} < 1$  for some  $^{235}\text{U}$  depleted waters
- $M_{235\text{U}}/M_{238\text{U}} = 0.0072 \pm 0.0001$  for  $\text{U}_{\text{nat}}$

# Total uranium (pCi/L) in ground water in the northern EFA/WFA study area, 2nd Quarter, 1994



262

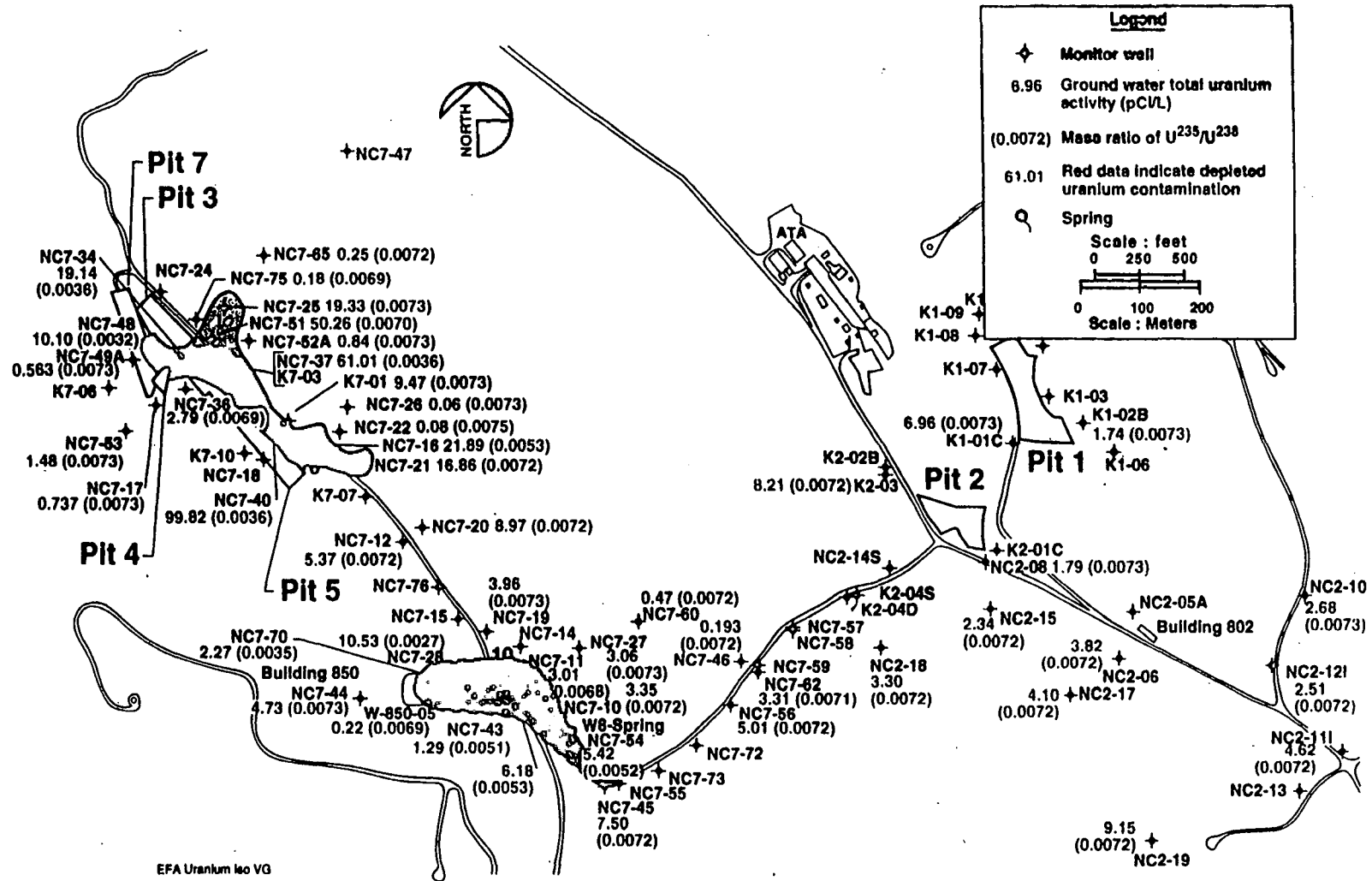

# Pit 7 Complex RCRA actions

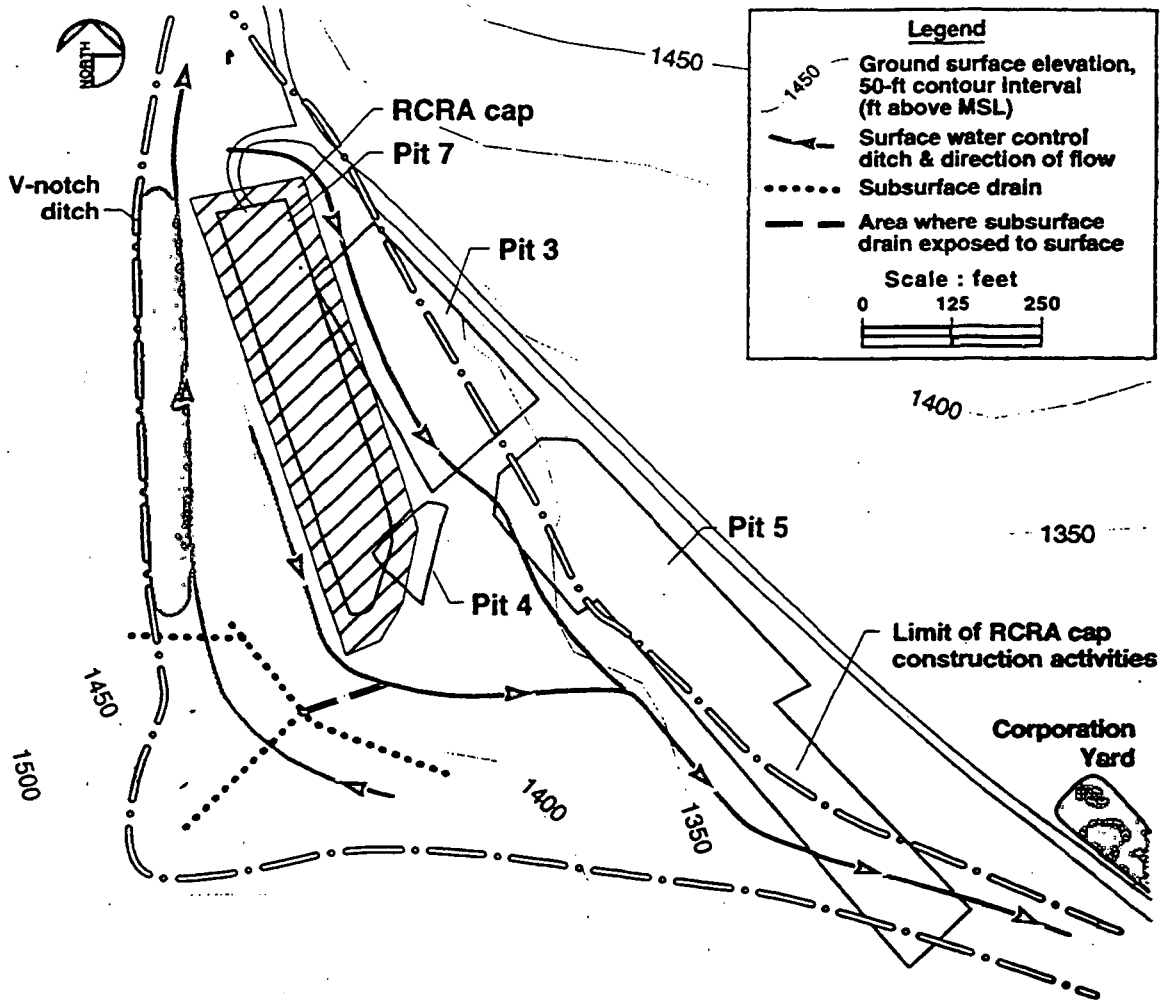

**V-notch ditch schematic cross-section**

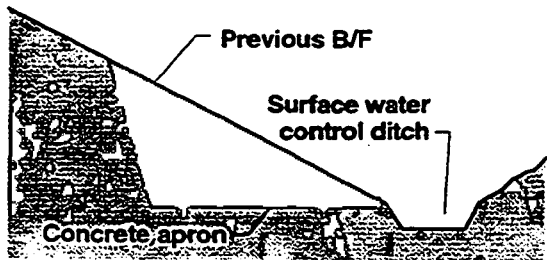

**Subsurface drain schematic cross-section**

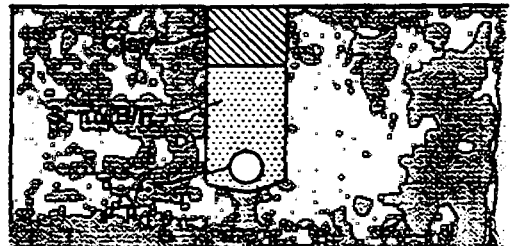

# Water level changes in the Pit 7 Complex, early February to late March, 1986

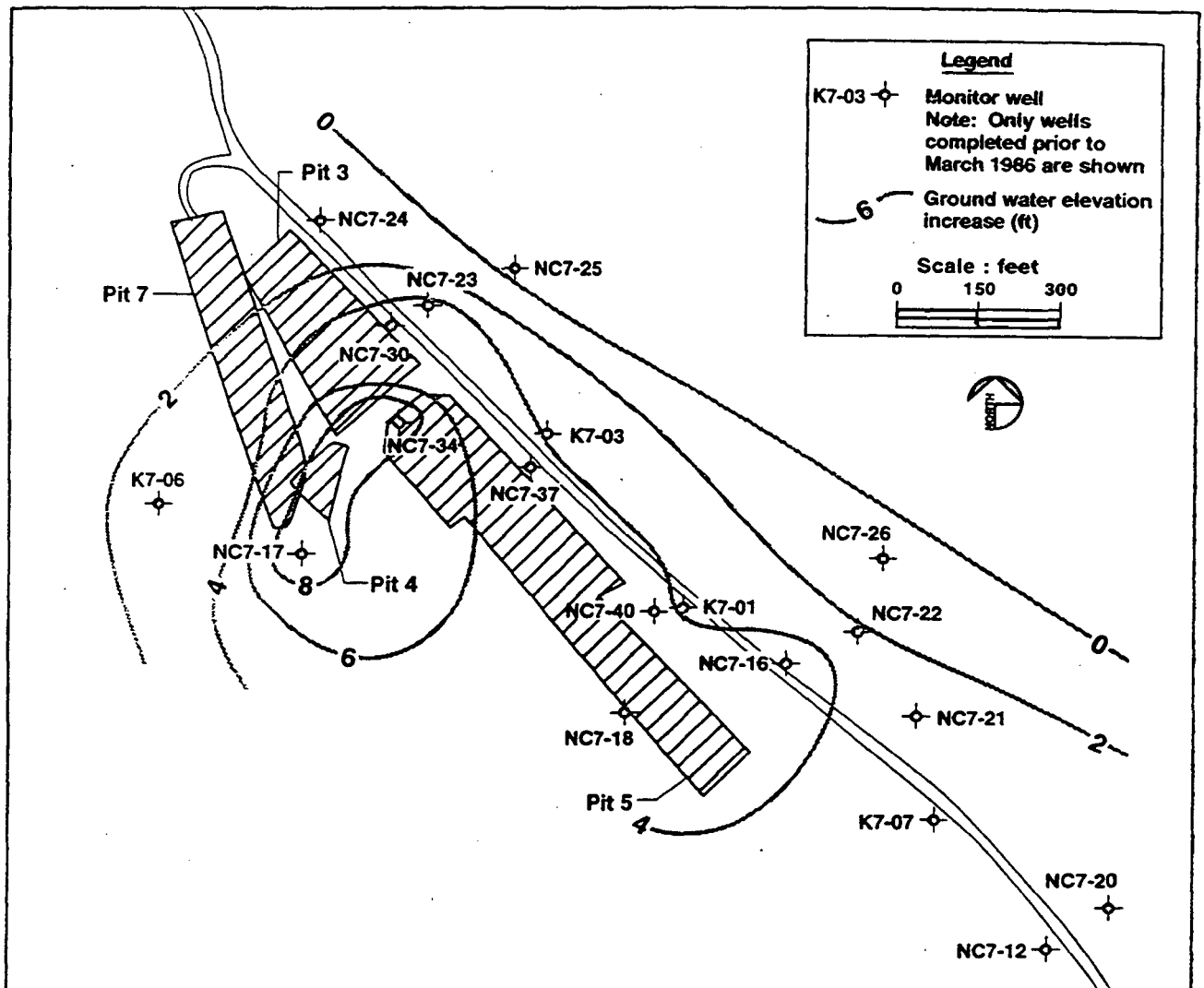

# Water level changes in the Pit 7 Complex, November 1992 – April 1993

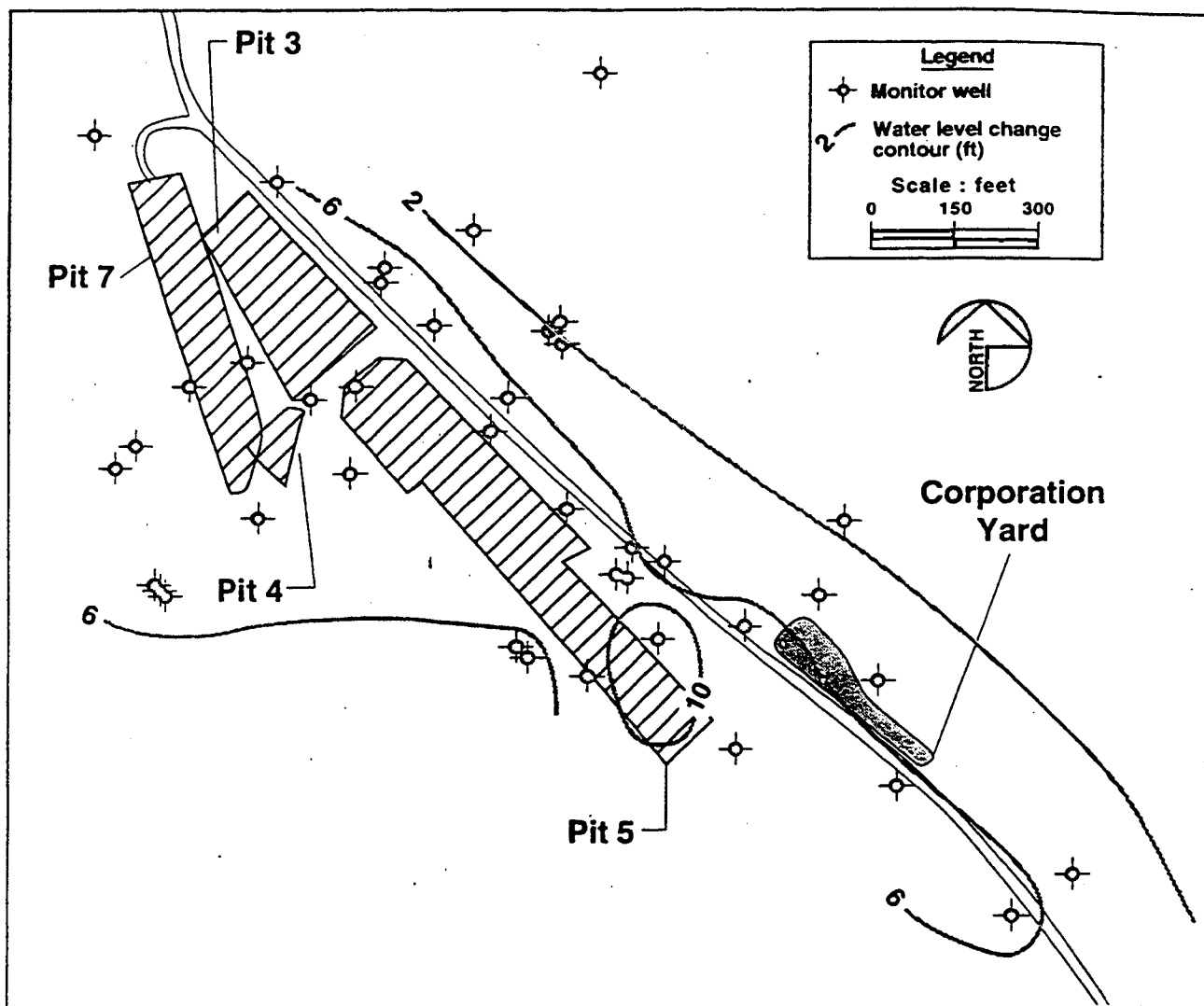

# Water level changes in the Pit 7 Complex, November 1994 – April 1995

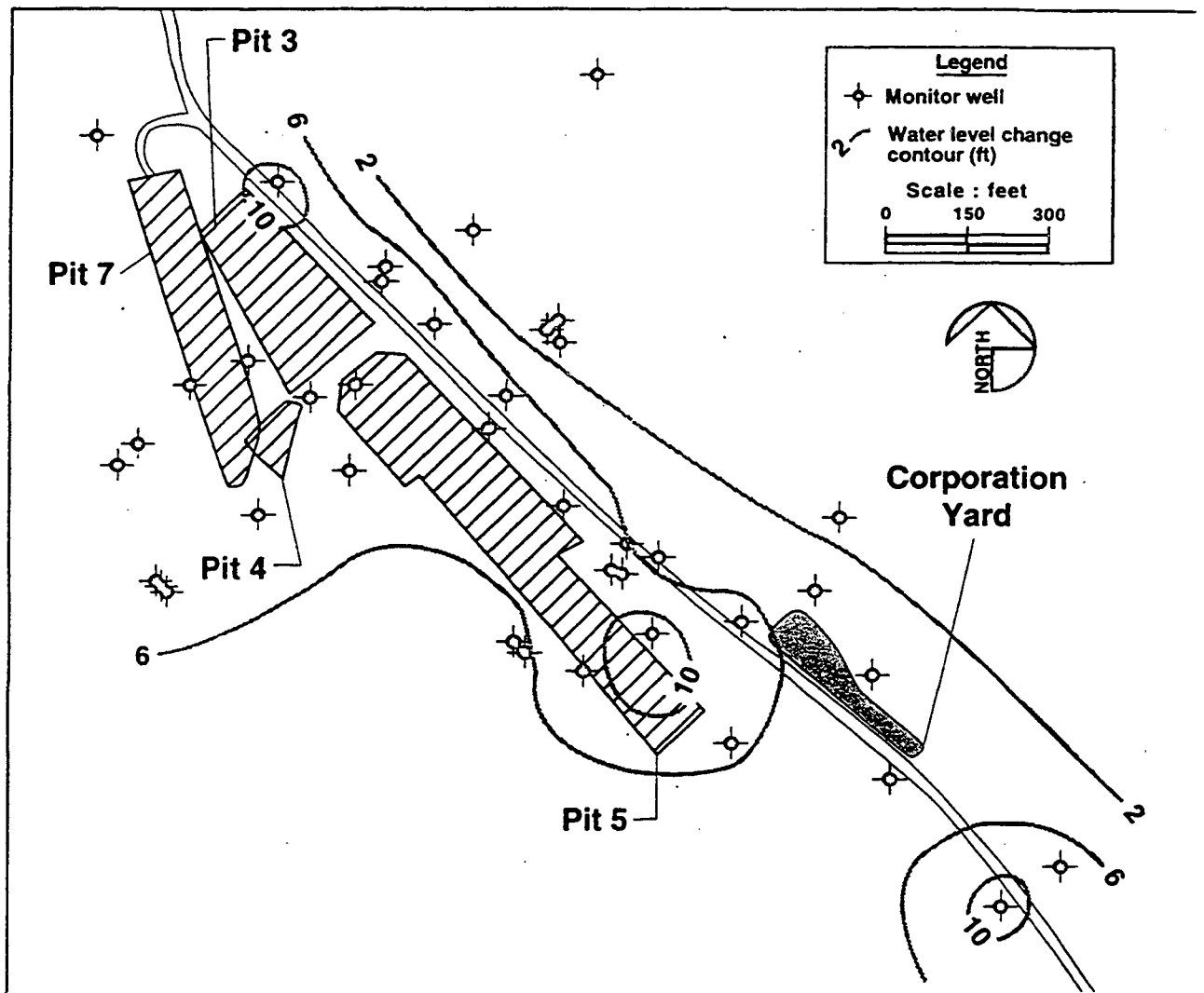



# Potential and/or actual exposure points in the EFA/WFA study area

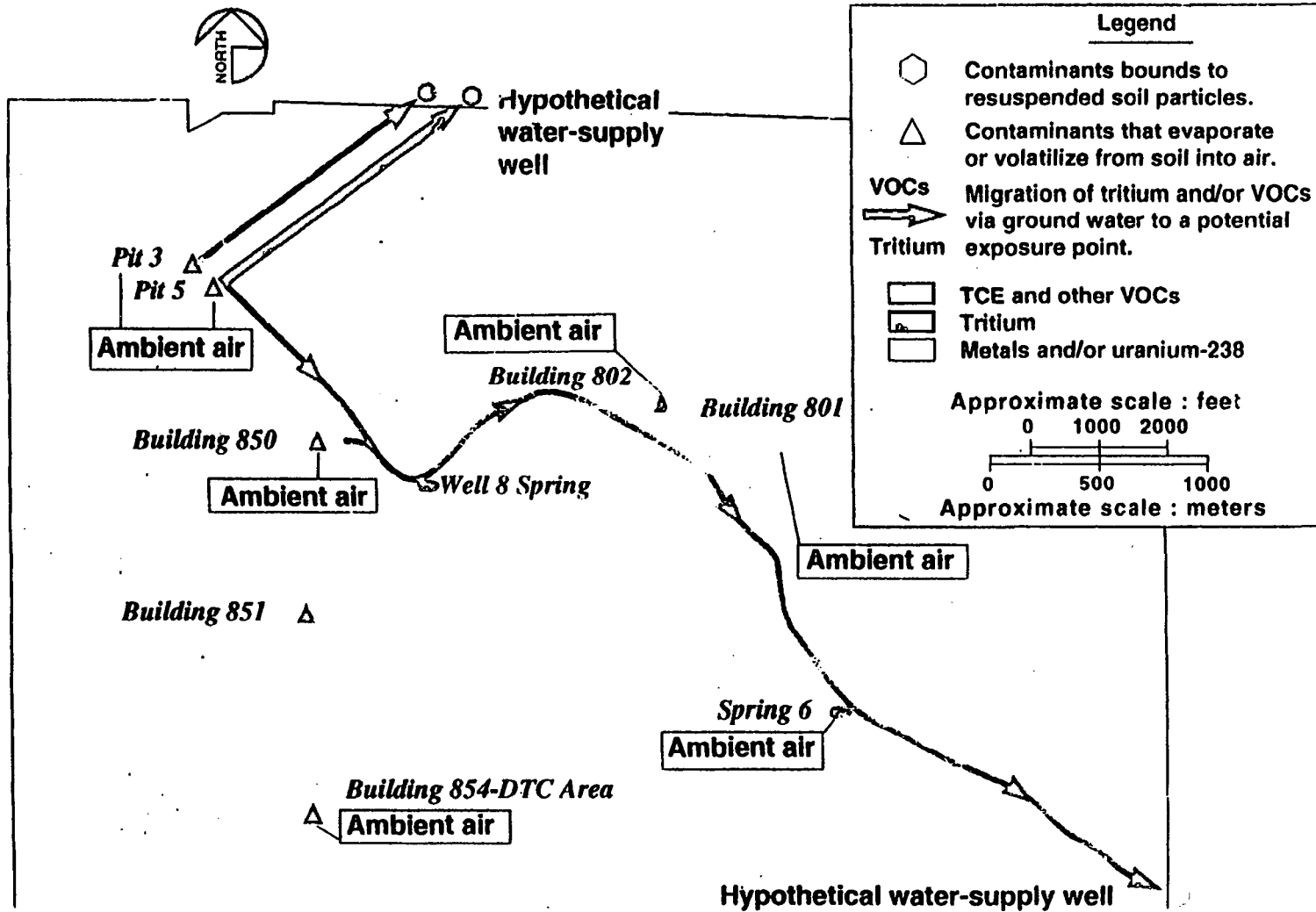

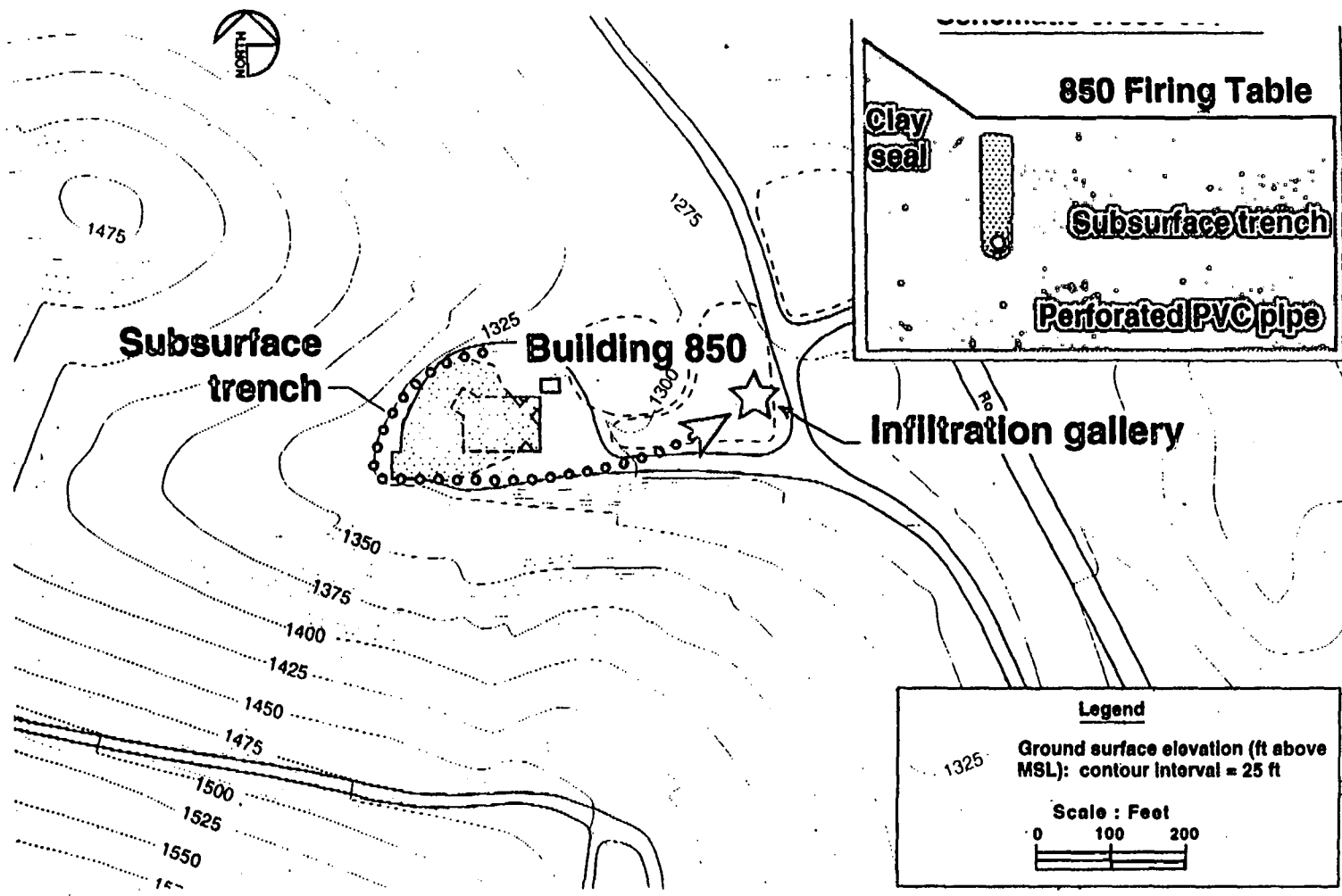

Subsurface trench

Building 850

Infiltration gallery

850 Firing Table

Clay seal

Subsurface trench

Perforated PVC pipe

Legend

Ground surface elevation (ft above MSL): contour interval = 25 ft

Scale : Feet

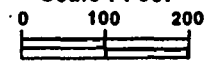

# Pit 7 Complex RCRA actions

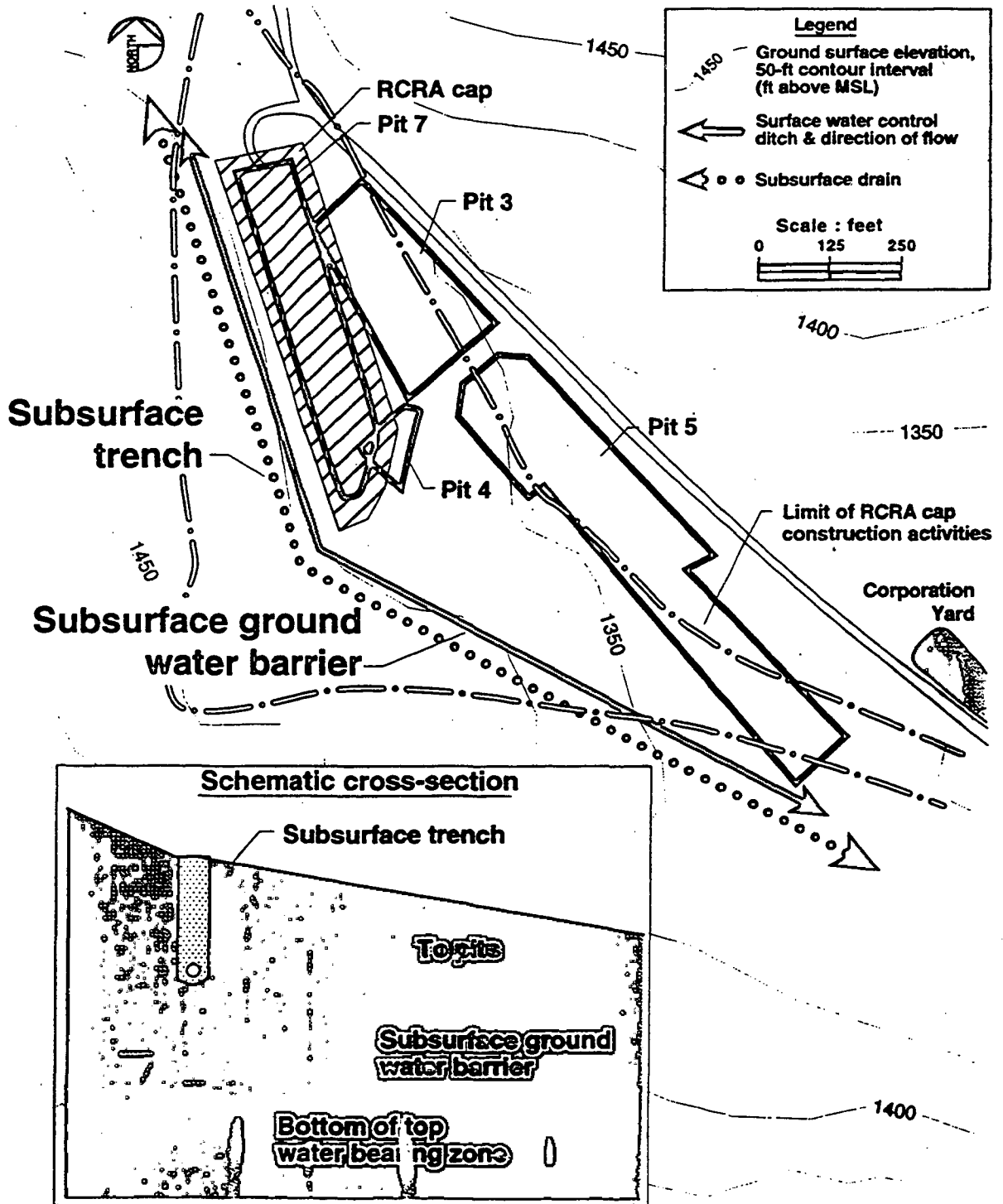

## Treatment technologies for tritium in water



- Electrolytic enrichment
- Thermal diffusion
- Vapor phase catalytic exchange/cryogenic distillation
- Liquid water distillation
- Combined electrolysis/catalytic exchange
- Membrane filtration
- Isotopic exchange
- Other techniques

## Combined electrolysis/catalytic exchange (CECE)

- Process begins with the electrolysis of tritiated water to produce HT gas, which is then injected into a series of columns packed with a metal catalyst
- De-ionized water is pumped into the column series, and the tritium is passed into the water with a net removal of H<sub>2</sub> gas (pervaporation)
- HTO concentration increases in the liquid as it moves down the column, while H<sub>2</sub> concentration increases in the gas as it moves up the column
- Electrolysis of the 4:3 liquid results in separate HT and O<sub>2</sub> gas streams
- CECE is perhaps the only technology that can reduce tritium activities in water to near-background levels
- Disadvantages:
  - Extremely energy intensive and only efficient at very large scales, and
  - Also has same disadvantages as electrolytic enrichment

## Membrane filtration

15

- Uses a 20 micron thick polyphosphazene membrane filter system that can remove up to 40% of the HTO in one pass
- Works due to the lower molecular diffusivity of tritium and the fact that more and larger water clusters form for HTO than H<sub>2</sub>O (lower temperatures [4 C] favor more clusters)
- Most inexpensive technology we studied-to treat 1.5 Mgal of water (from 3M pCi/L to 20K pCi/L)
  - Membrane system could be purchased for less than \$1M
  - Annual maintenance costs would be about \$130K
  - Ground water extraction, transport, disposal, and administration costs not included
- Disadvantages:
  - Still experimental-yet to be applied to treating ground water
  - Mineralization and co-contaminant effects on filters require evaluation

# Cost Summary

---

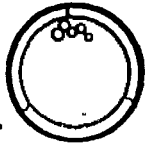

## Building 850

- Institutional controls and monitoring (up front costs) \$140K
- Monitoring (annual costs) \$ 75K
- Interceptor trench and infiltration gallery \$750K

## Pits 3 and 5

- Institutional Controls and Monitoring (up front costs) \$100K
- Monitoring (annual costs) \$ 80K
- East Side V-notch Ditch \$340K
- Barrier and Trench \$6.2M



## Summary

---

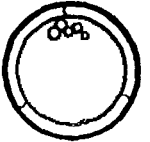

- **We integrated many investigative techniques to develop our conceptual models.**
- **Complex geologic structures in the area complicate hydrogeology**
- **Observation of tritium migration improved our conceptual hydrogeologic model**
- **Chemicals migrating in ground water from the Building 850/landfill area pose a low human health risk**
- **Despite the low risk, we are designing conceptual engineering solutions to prevent future releases to ground water**





# **HydroPhysical™ Logging: A Review of Applications and Case Studies**

**William H. Pedler**  
COLOG, Inc.  
Golden, Colorado

July 8 - 9, 1997

## **JOINT RUSSIAN-AMERICAN HYDROGEOLOGY SEMINAR**

Russian - American Center for Contaminants Transport Studies  
Ernest Orlando Lawrence Berkeley National Laboratory  
Berkeley, California 94720

# HydroPhysical™ Logging : A Review of Applications and Case Studies

at

JOINT RUSSIAN-AMERICAN HYDROGEOLOGY SEMINAR  
Russian - American Center for Contaminants Transport Studies  
Ernest Orlando Lawrence Berkeley National Laboratory  
Berkeley, California 94720

by

William H. Pedler  
Research Hydrogeologist  
COLOG, Inc.  
Golden, CO

## HYDROPHYSICAL™ LOGGING SUMMARY

- Technique applicable in a wide variety of hydrogeologic settings: low to high yield bedrock, alluvial/porous settings, karst and volcanic aquifers
- Both open boreholes and completed wells can be characterized
- Water bearing intervals are identified to one borehole diameter resolution
- A wide range of interval specific flow rates can be quantified (0.01 to 100+ gpm)
- Flow rates can be assessed independent of borehole diameter
- Wellbore flow is evaluated under ambient or stressed aquifer conditions
- Larger volume of aquifer is investigated than by traditional packer testing
- HpL™ is more time and cost effective than packer testing
- Interval specific water quality can be evaluated
- Capable of single and cross-hole aquifer characterization (i.e. evaluate larger scale hydraulic connections between two or more wells)
- Equivalent data output as packer testing ( $\Delta p$  and  $\Delta q$ ) for transmissivity and hydraulic conductivity calculations

# HYDROPHYSICAL™ LOGGING TEST PROTOCOLS

## SINGLE WELL TESTS

Ambient flow evaluation (both vertical and horizontal flow)

*emplacement and continuous FEC profiling*

### Very Low Yield Wells

→ Slug or Rising Head Test after DI Emplacement

*emplacement, baseline log, slug removal and periodic FEC logs*

### Low to Moderate Yield Wells

→ Low Rate Pumping after DI Emplacement

*emplacement, baseline log, low rate pumping and continuous FEC logs*

### Moderate to High Yield Wells

→ Pumping During DI Injection

*pumping and FEC logging until quasi-steady state drawdown condition,  
start DI injection,  
raise pumping rate to maintain constant formation production rate,  
continuous FEC logging until stable, diluted FEC logs observed*

## CROSS-HOLE TESTS

Ambient flow evaluation of observation wells under stable well field conditions

*emplacement and continuous FEC logging*

Initiate pumping and monitor water levels

*traditional pump test activities*

Cross-hole flow evaluation in observation wells

*emplacement and continuous FEC logging*

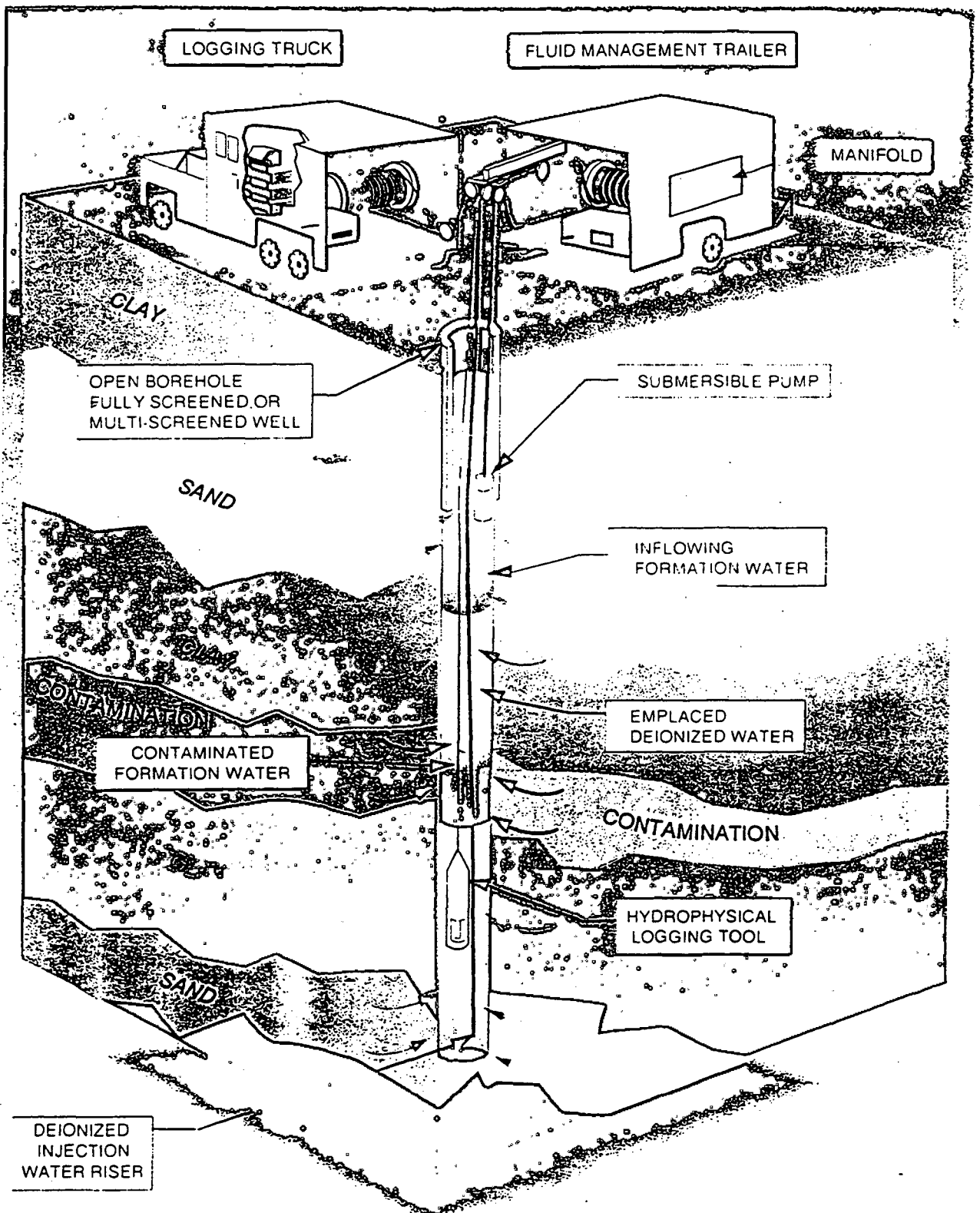

The HpL technique involves injection of environmentally safe deionized water into the wellbore and logging over time to attain FEC profiles. HpL can be conducted in an open, competent borehole in hard rock or in a fully completed, single or multi-screened/perforated well.

# Principles of HpL Logging

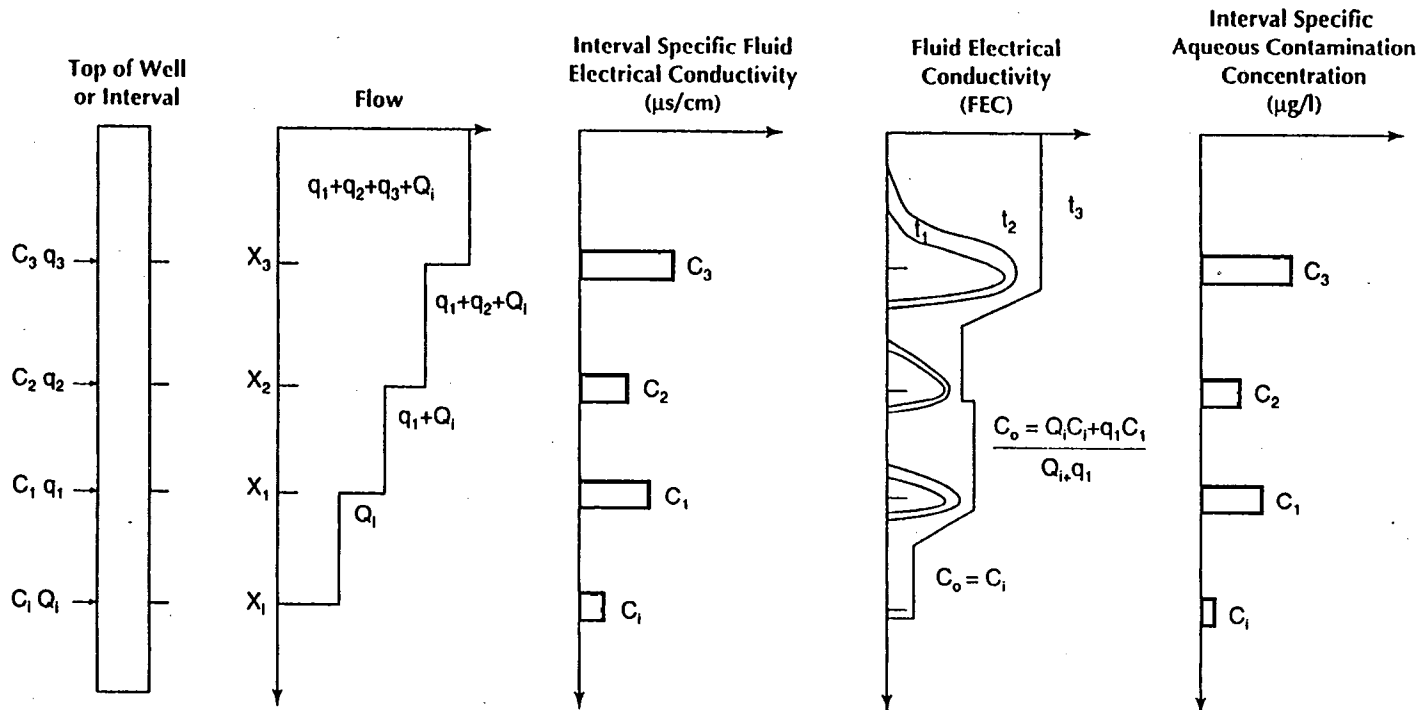

Schematic of well with multiple producing zones. During pumping/non-pumping conditions, each zone is characterized by two parameters: volumetric rate of inflow/outflow,  $q_i$ , and interval specific concentration,  $c_i$ , of the constituent of interest. These constituents range from total dissolved solids (TDS), pH, and hardness (calcium, magnesium, iron) to aqueous phase VOCs, pesticides and radionuclides.

Flow schematic with the pump set above the uppermost producing intervals (e.g. fractures): a step change increase in flow will occur at each producing interval. As fluid moves from the bottommost interval toward the pump, the flow rate will increase in a step-like function until the point above  $X_3$  where total flow is observed.

In addition to quantification of flow, HpL evaluates interval specific fluid electrical conductivity (~TDS).

The integrated relationship between flow and FEC results in a unique time series of electrical conductivity profiles during pumping after the borehole is flushed with deionized water.

As HpL can identify water bearing zones during pumping, a downhole discrete point fluid sampler can be used during flowing conditions to obtain samples above each interval. The observed concentrations generated by this hydrochemical analysis and the interval specific flow rates are used to calculate "actual" (pore water) concentrations of any aqueous phase contaminant.

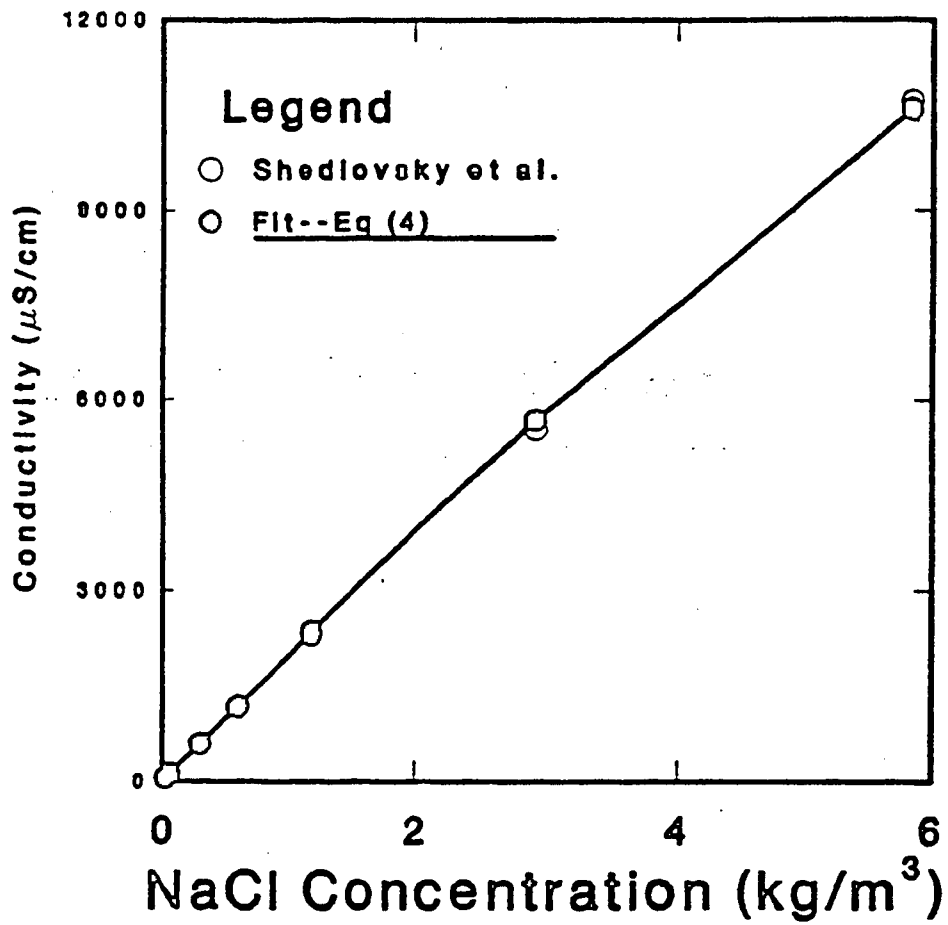

Figure 2-1. Conductivity vs. concentration.



FIGURE 2. SUMMARY OF FEC LOGS FOR AMBIENT VERTICAL FLOW CHARACTERIZATION, LETTERKENNY ARMY DEPOT, CHAMBERSBURG, PA; WELL 95-DA6

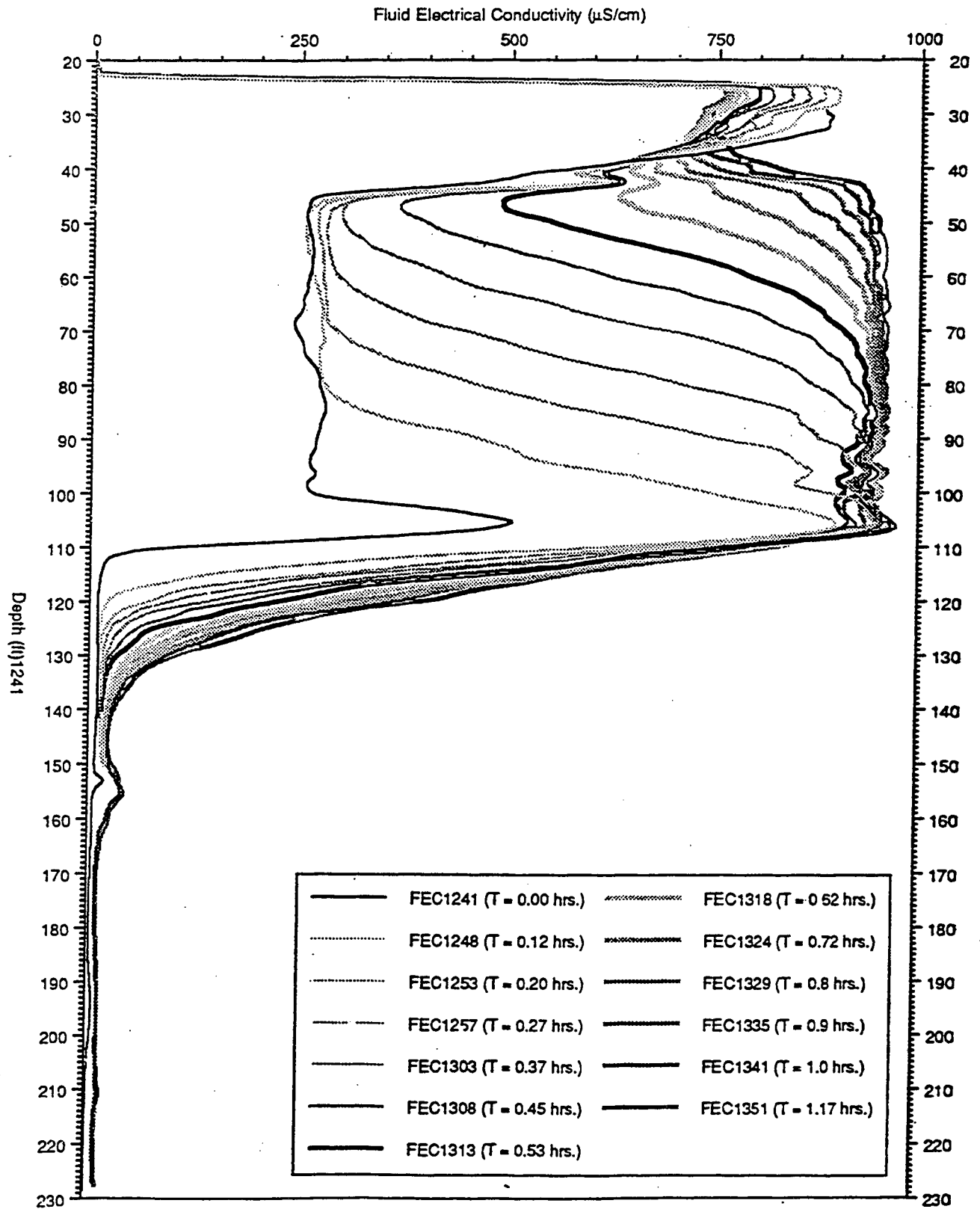

FIGURE 9. SUMMARY OF FEC LOGS DURING AMBIENT FLOW CHARACTERIZATION, LETTERKENNY ARMY DEPOT, CHAMBERSBURG, PA; WELL 95-DA7.

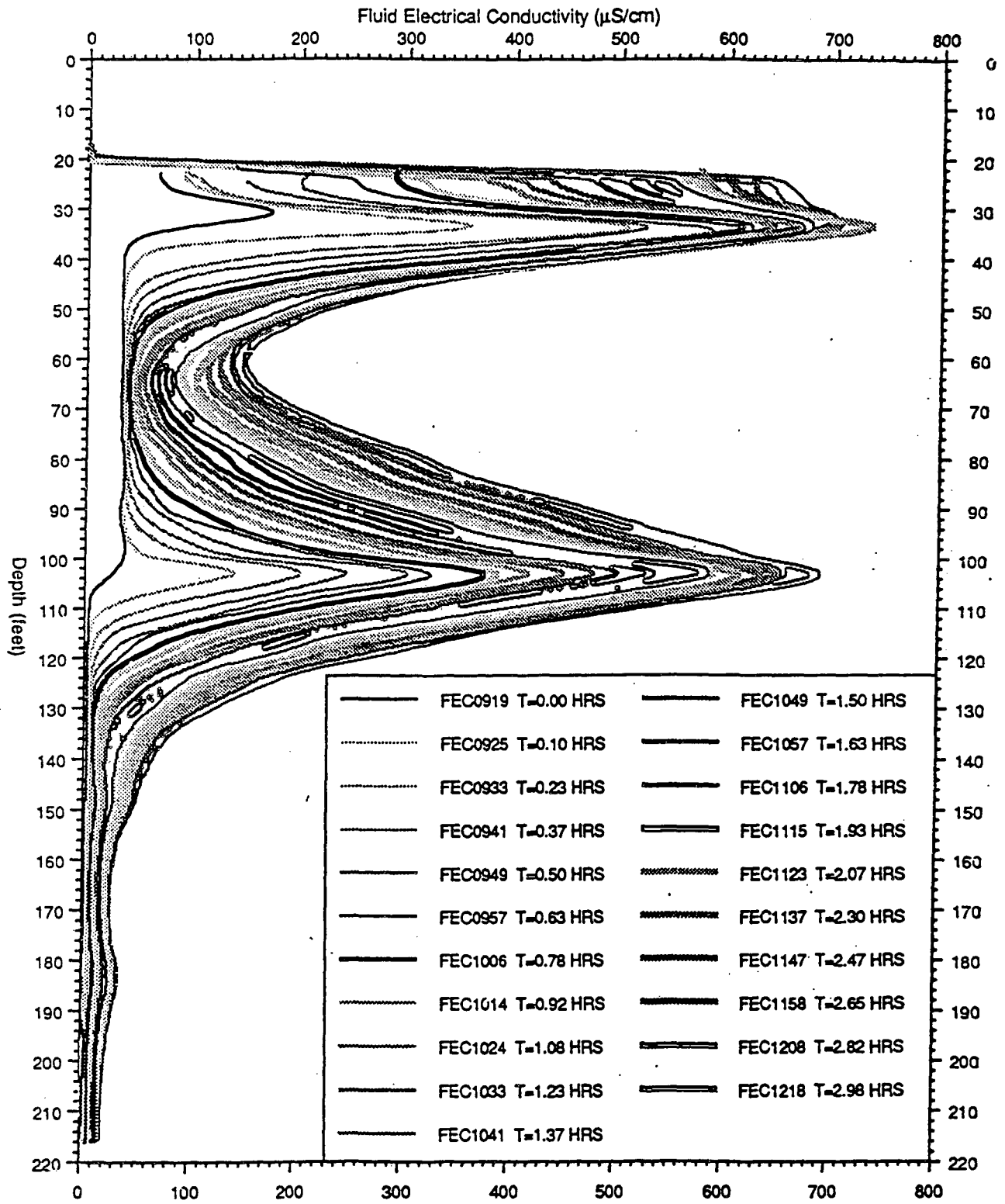

FIGURE 10. CHROMOGRAPHIC SUMMARY OF FEC LOGS DURING AMBIENT VERTICAL FLOW CHARACTERIZATION, LETTERKENNY ARMY DEPOT, CHAMBERSBURG, PA; WELL 95-DA7.

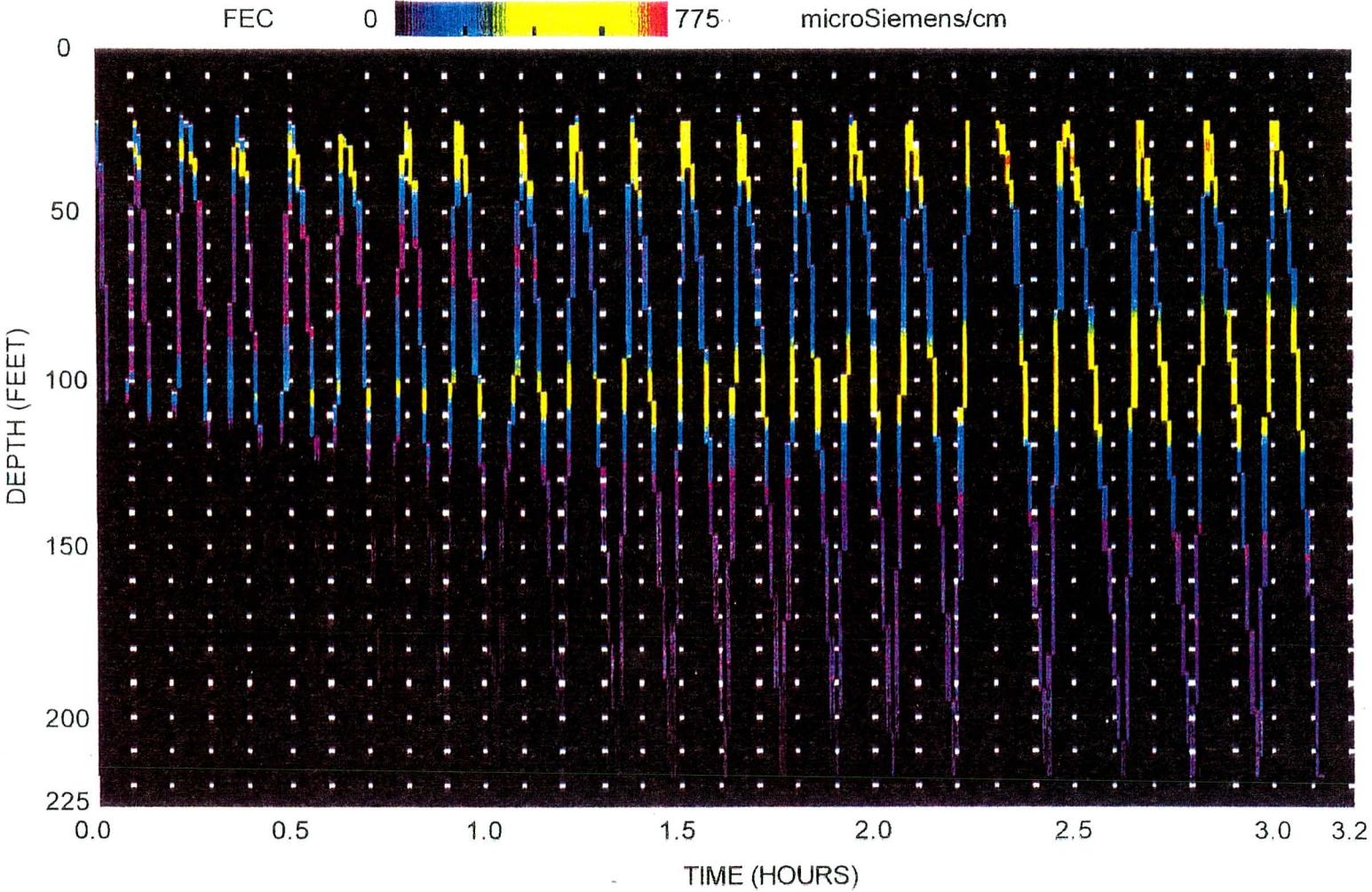
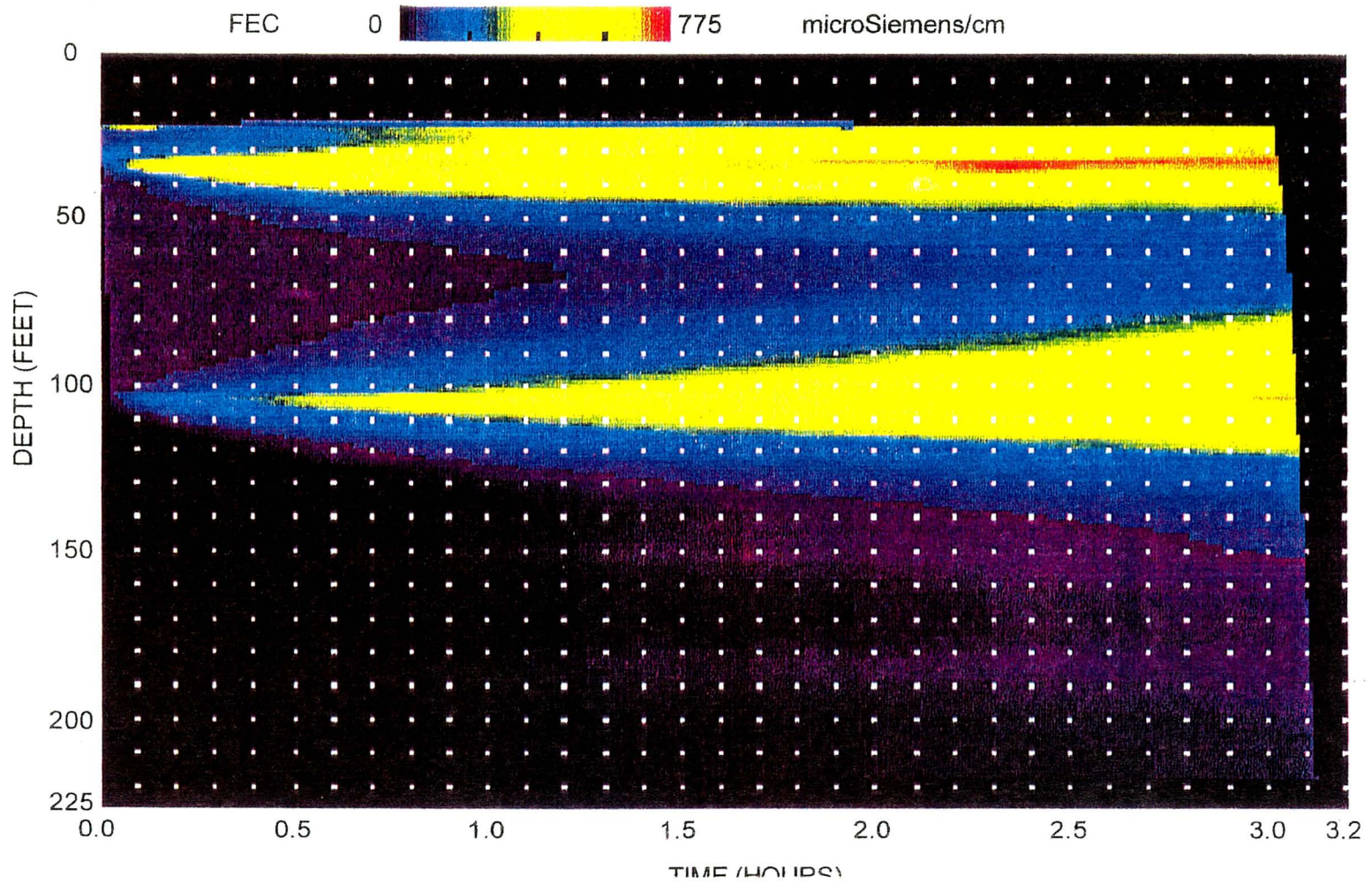

FIGURE 11. CHROMOGRAPHIC TESSELLATION OF FEC LOGS DURING AMBIENT VERTICAL FLOW CHARACTERIZATION, LETTERKENNY ARMY DEPOT, CHAMBERSBURG, PA; WELL 95-DA7.



**FIGURE W202AR1:3. SUMMARY OF HYDROPHYSICAL LOGS FOR SLUG TEST AFTER EMPLACEMENT; WELL: W202AR1.**

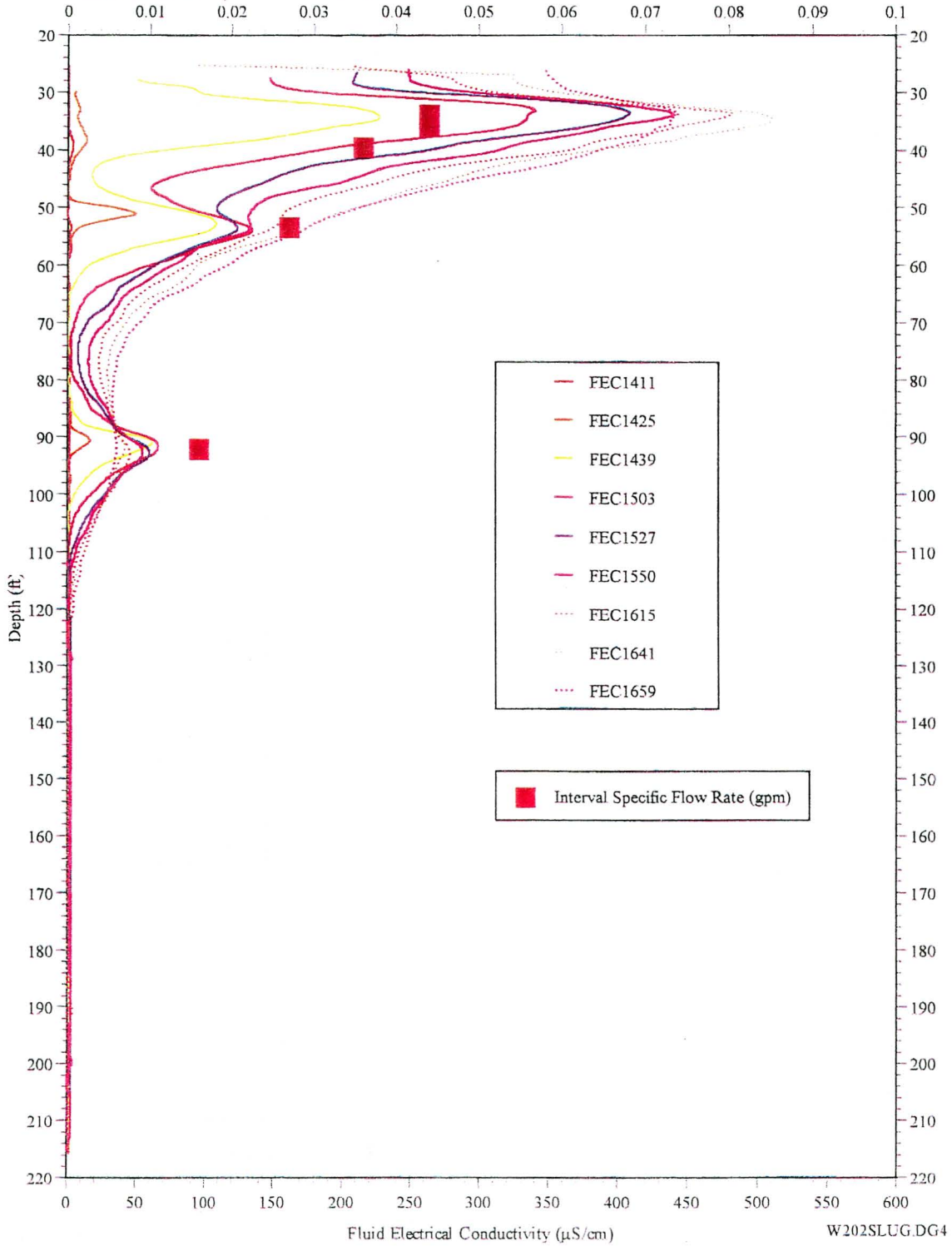
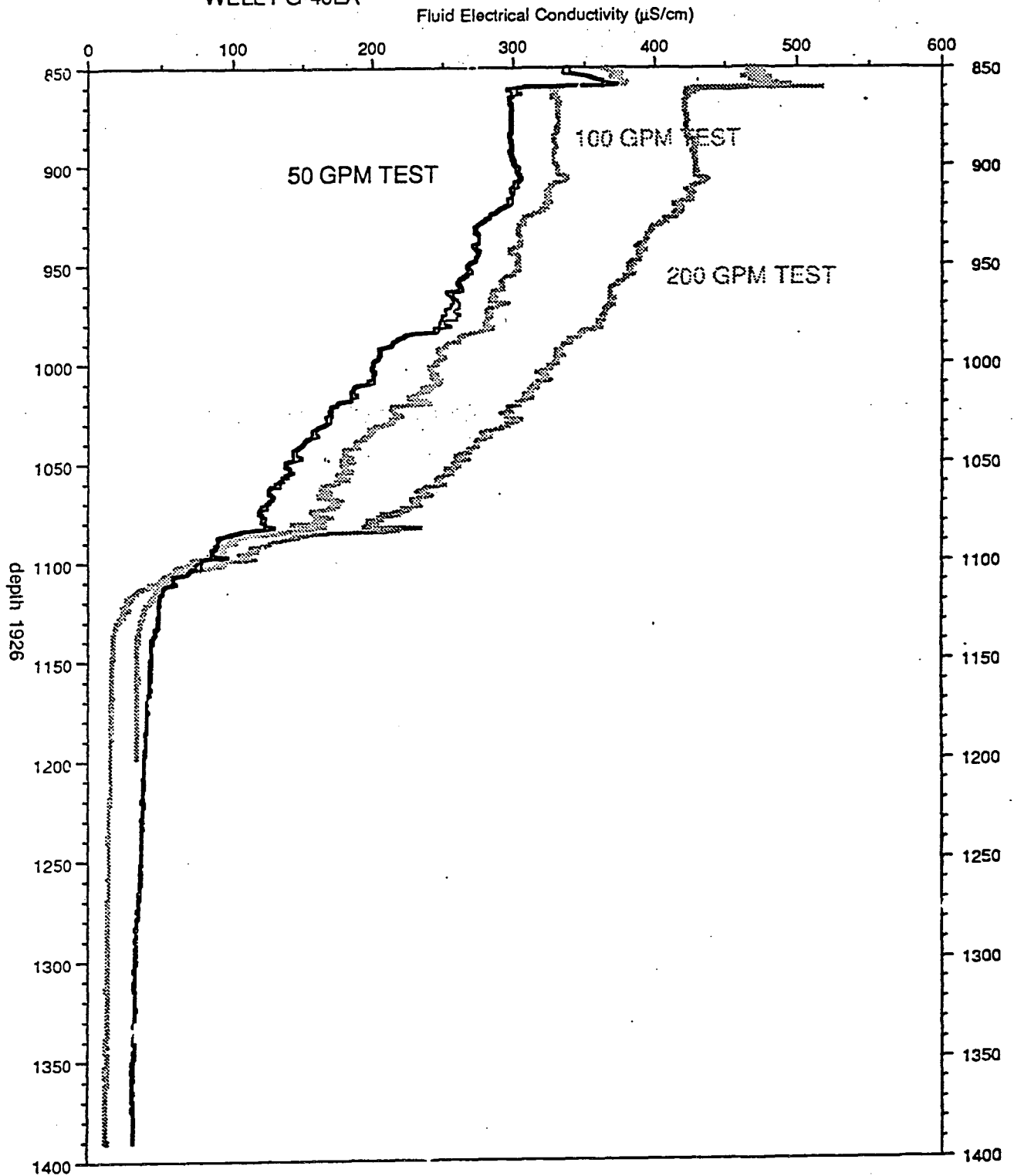

FIGURE 15. SUMMARY OF HYDROPHYSICAL LOGS DURING PUMPING AT 50, 100, AND 200 GPM, NORTH INDIAN BEND WASH SITE, SCOTTSDALE, AZ; WELL PG-40LA



**FIGURE W205CH1:3. SUMMARY OF HYDROPHYSICAL LOGS FOR PUMP AFTER EMPLACEMENT TEST; WELL: W205CH1**

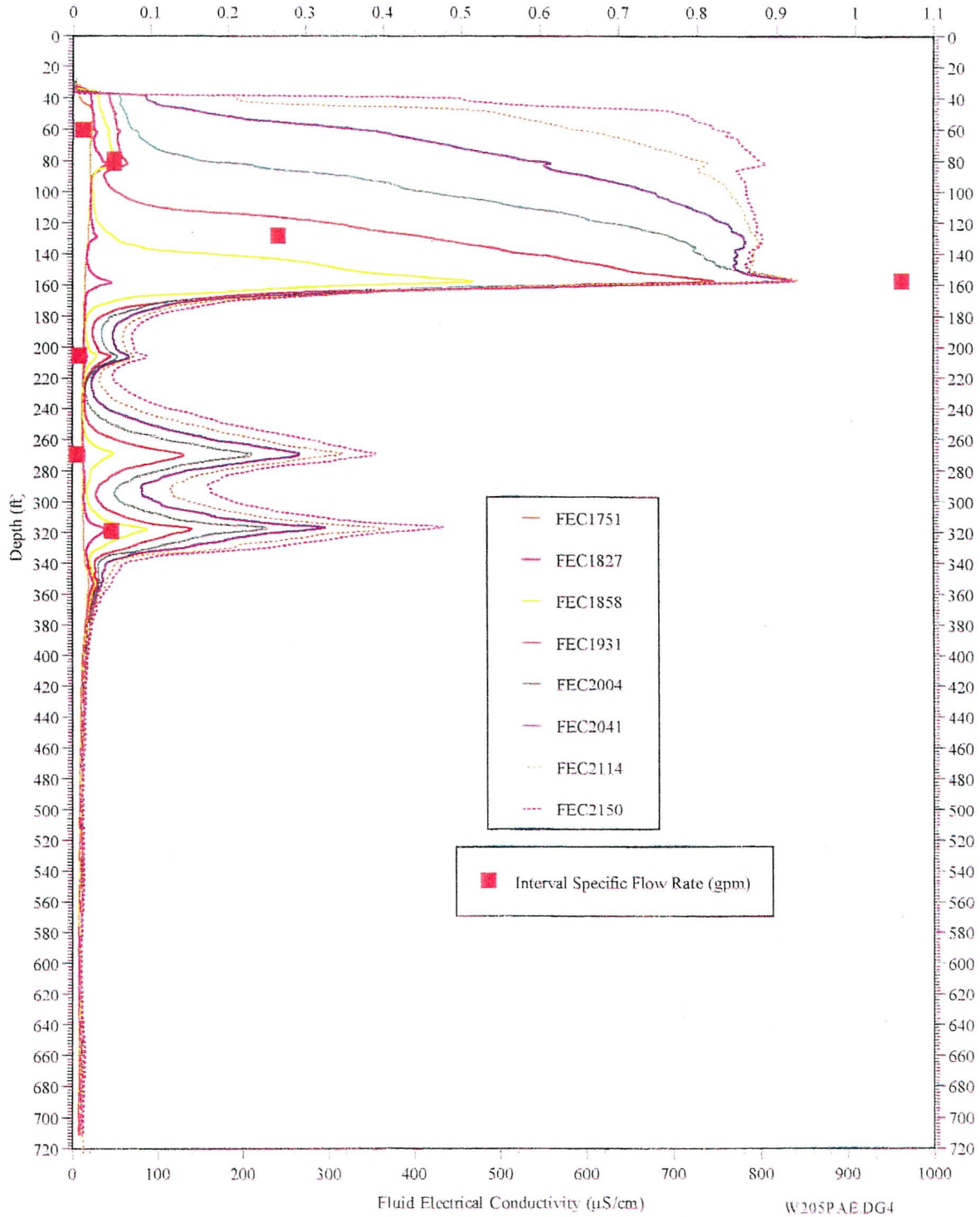

FIGURE 16 SUMMARY OF HYDROPHYSICAL RESULTS DURING PRODUCTION TESTS;  
 NORTH INDIAN BEND WASH SITE, SCOTTSDALE, AZ; WELL PG-40LA

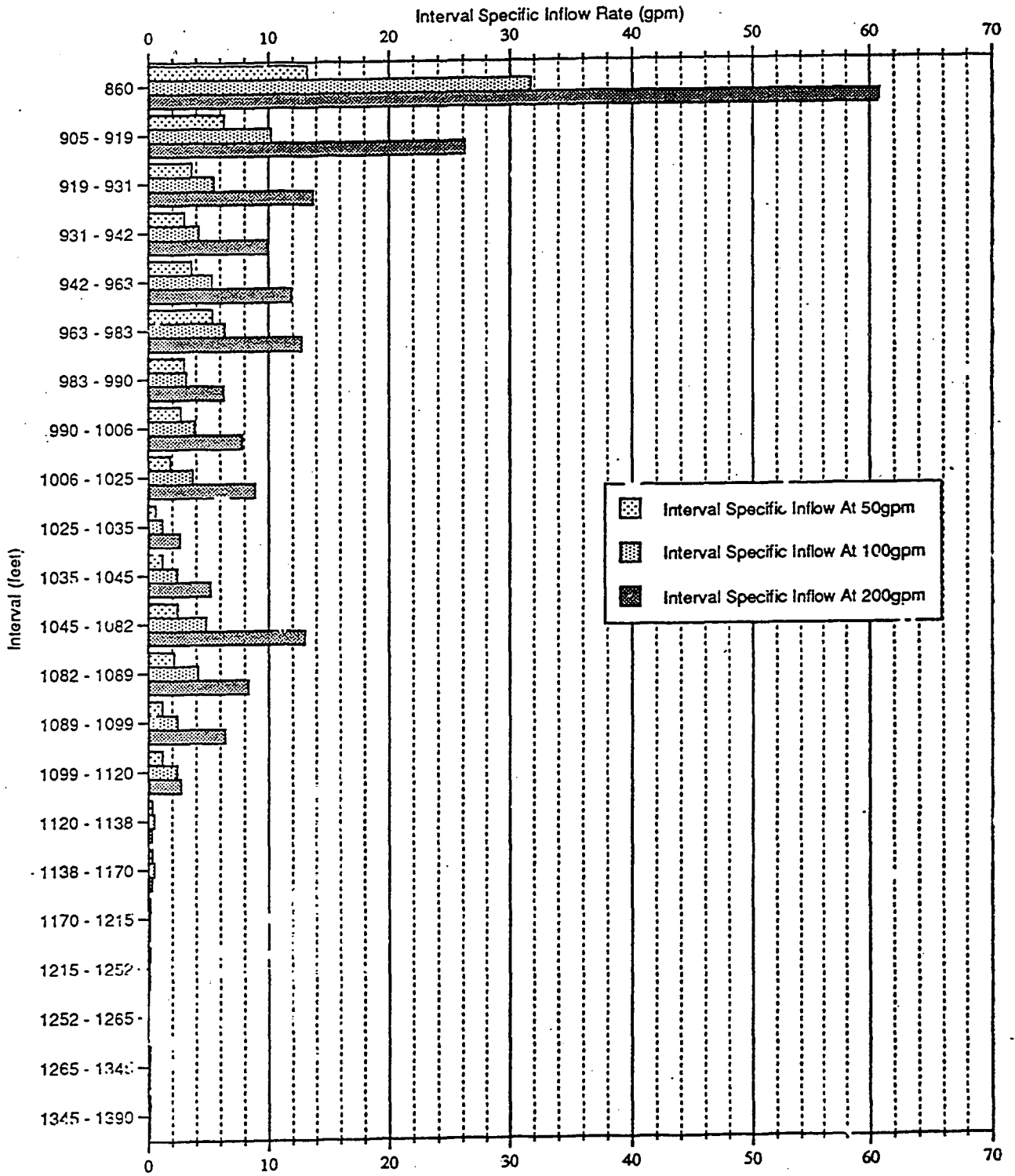



FIGURE 17. ESTIMATED INTERVAL SPECIFIC TRANSMISSIVITY, NORTH INDIAN BEND WASH SITE, SCOTTSDALL, AZ; WELL PG-40LA.

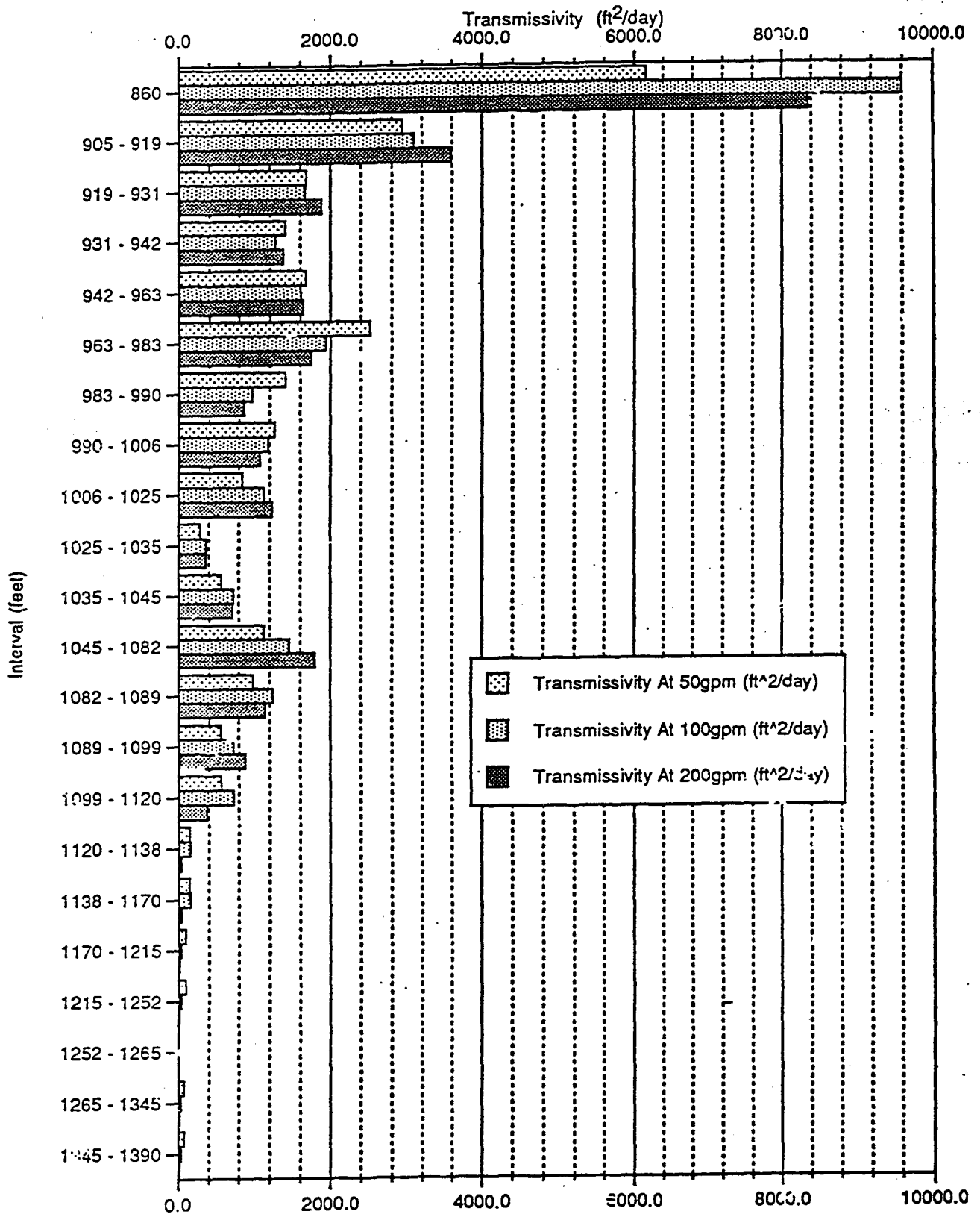

FIGURE 6. SUMMARY OF FEC LOGS DURING WELL PRODUCTION TEST, LETTERKENNY ARMY DEPOT, CHAMBERSBURG, PA; WELL 95-DA6

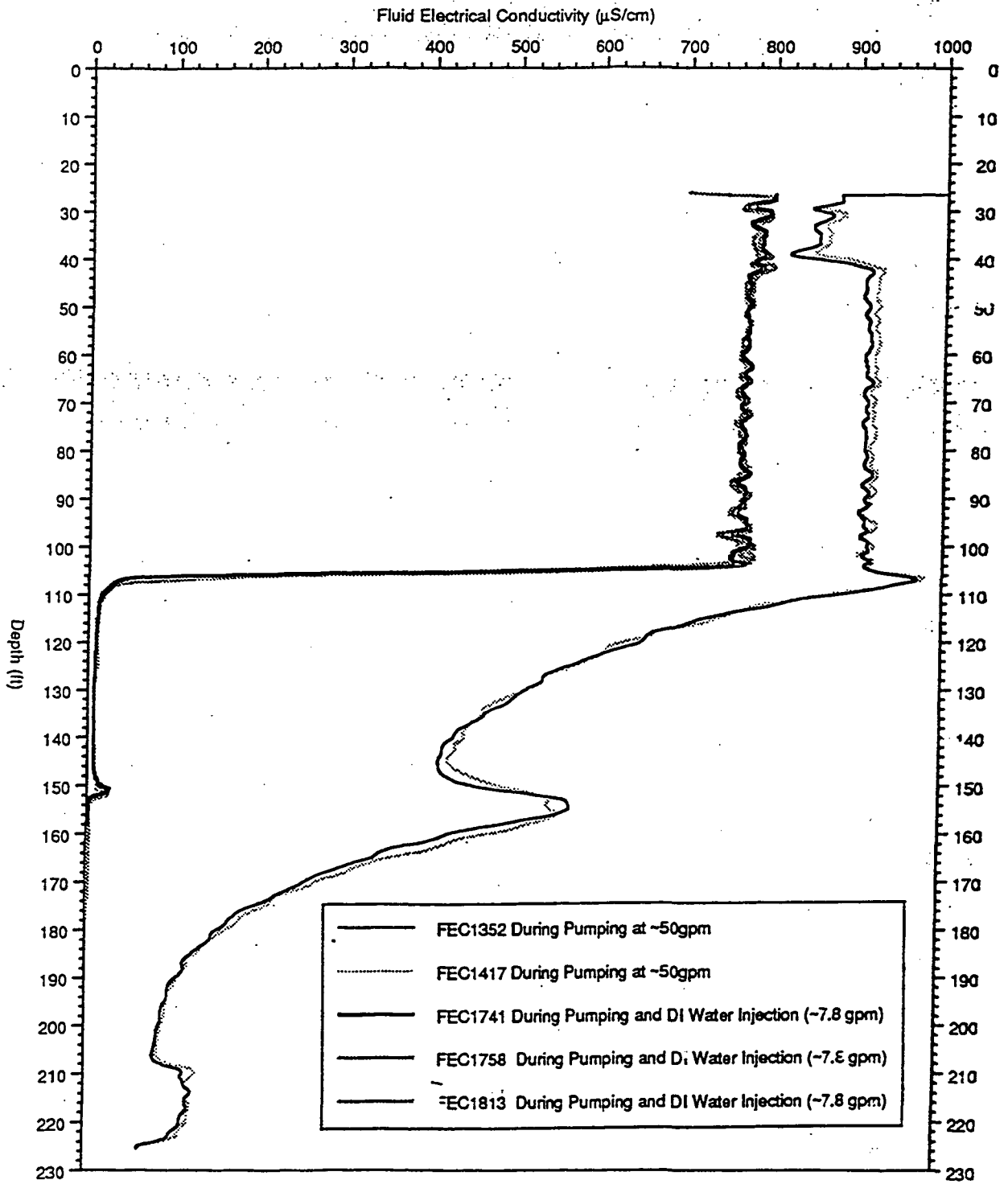
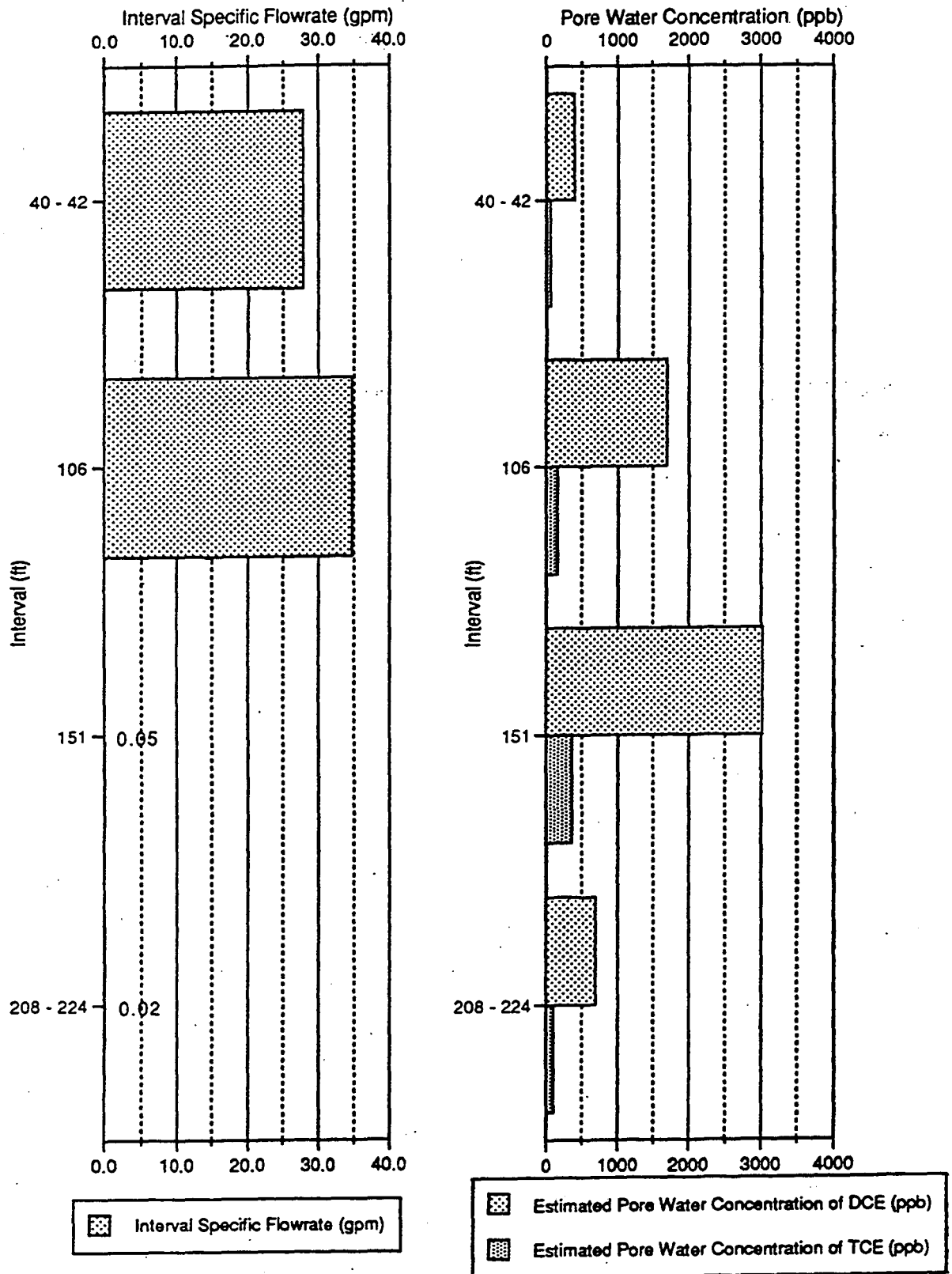
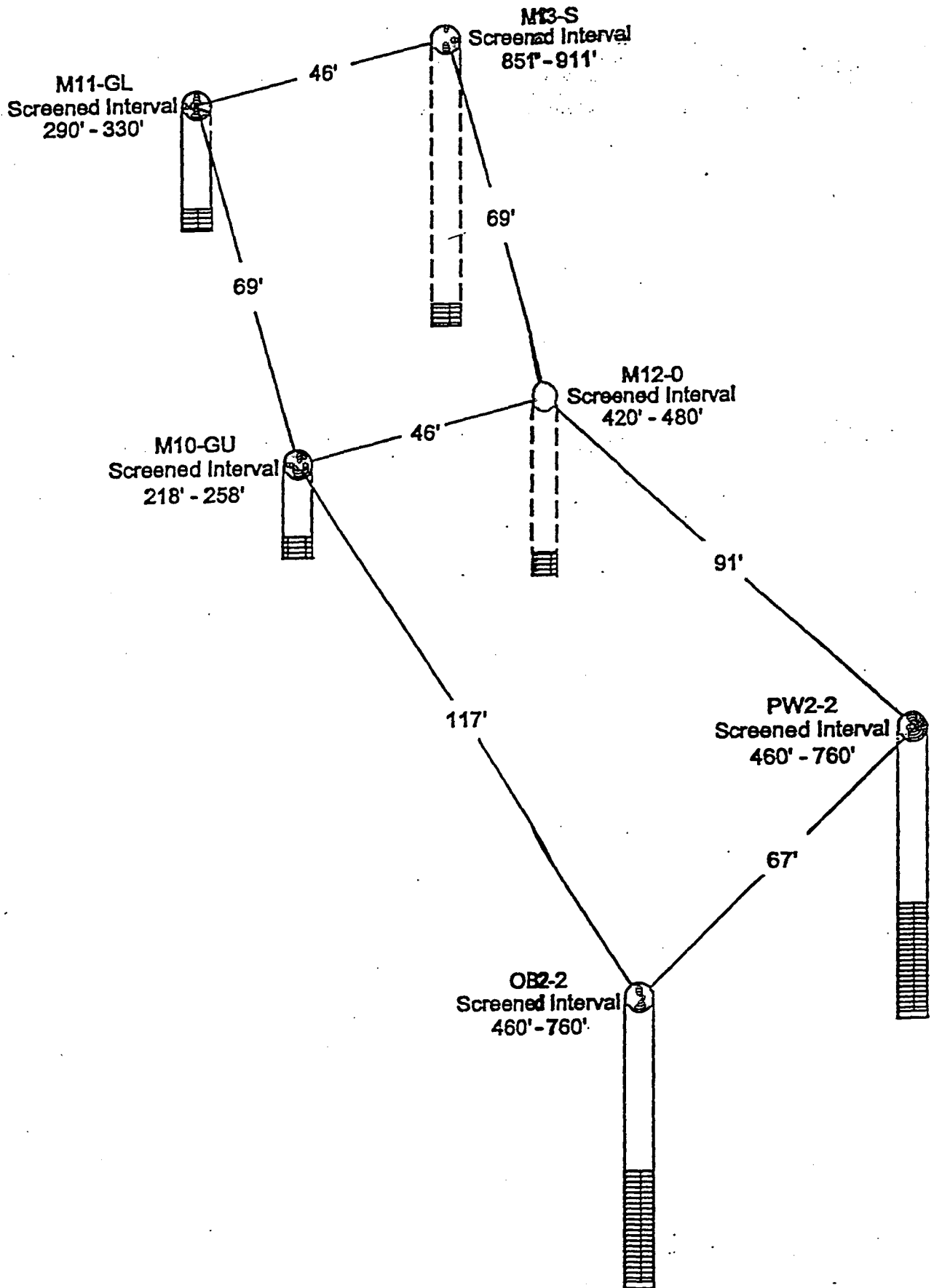
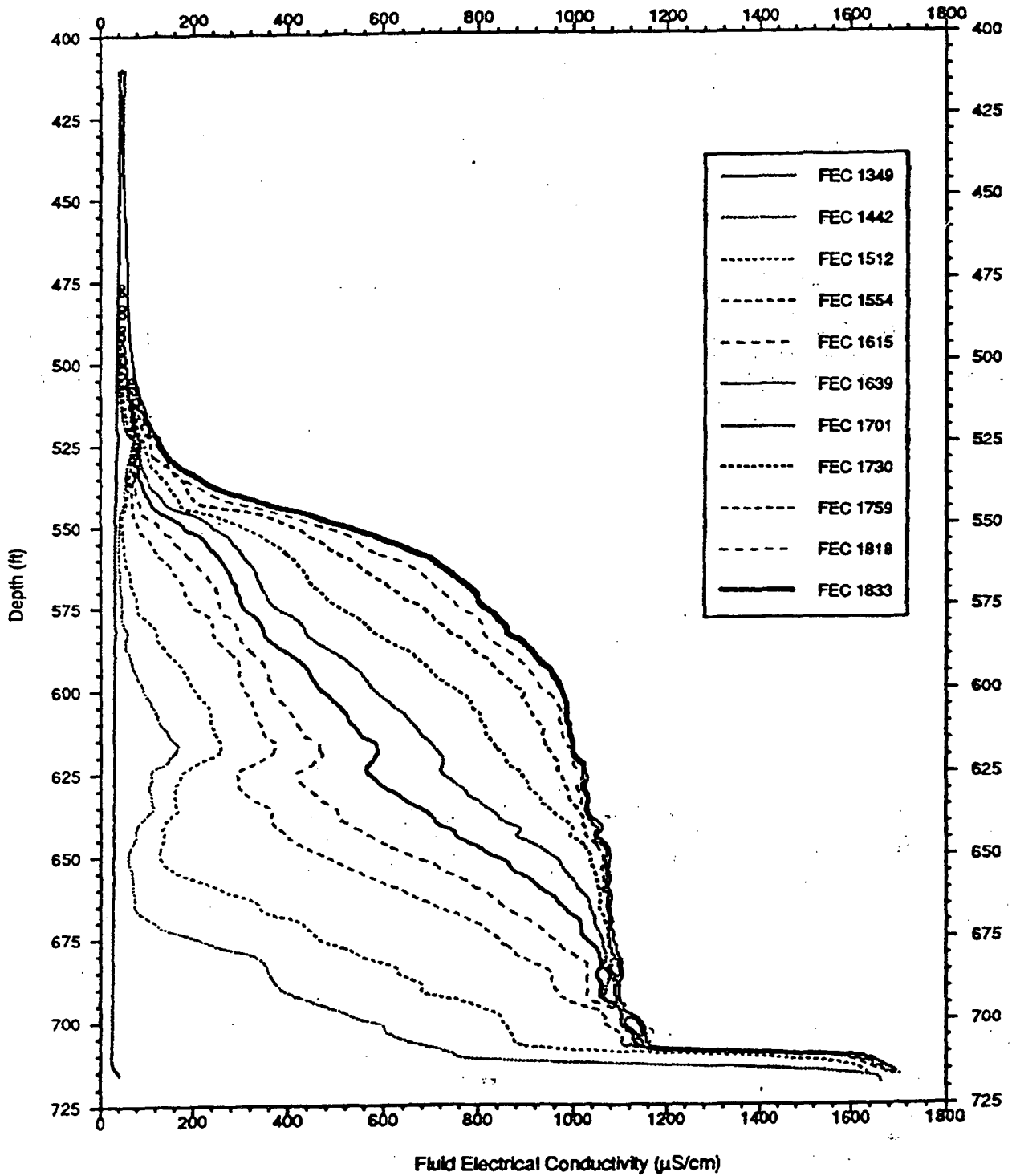

FIGURE 7. SUMMARY PLOT OF CODE BORE RESULTS AND PORE WATER CONTAMINANT CONCENTRATIONS, LETTERKENNY ARMY DEPOT, CHAMBERSBURG, PA; WELL 95-DA6





**Summary of HydroPhysical™ Logs for Ambient Flow  
Characterization, Stable Wellfield Conditions  
Well OW2-2**



# Summary of HydroPhysical™ Logs for Ambient Flow Evaluation and Cross Hole Testing Well OB2-2

FEC 0 1750

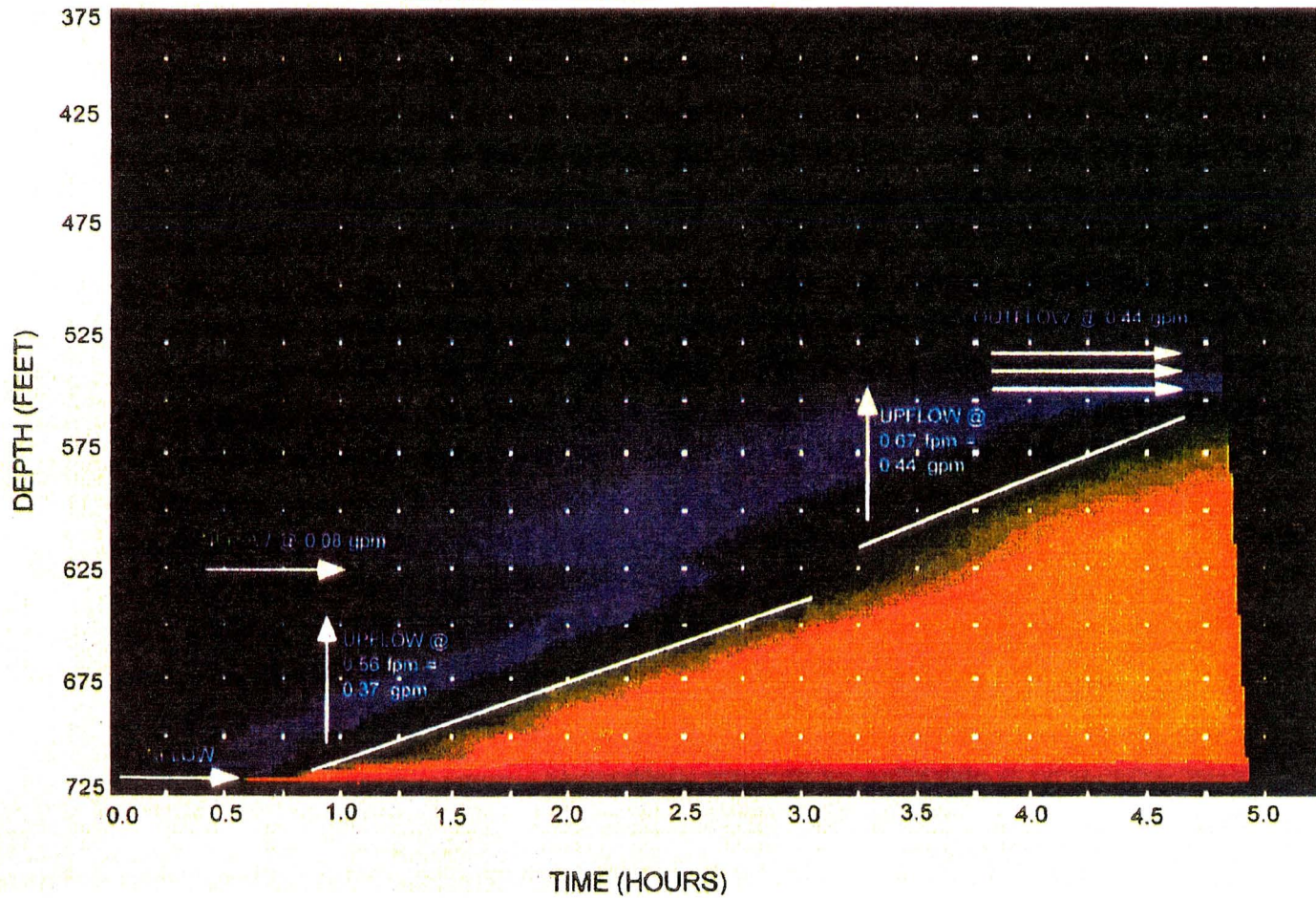

# Summary of HydroPhysical™ Logs for Ambient Flow Characterization During Pumping of PW2-2 Well OB2-2

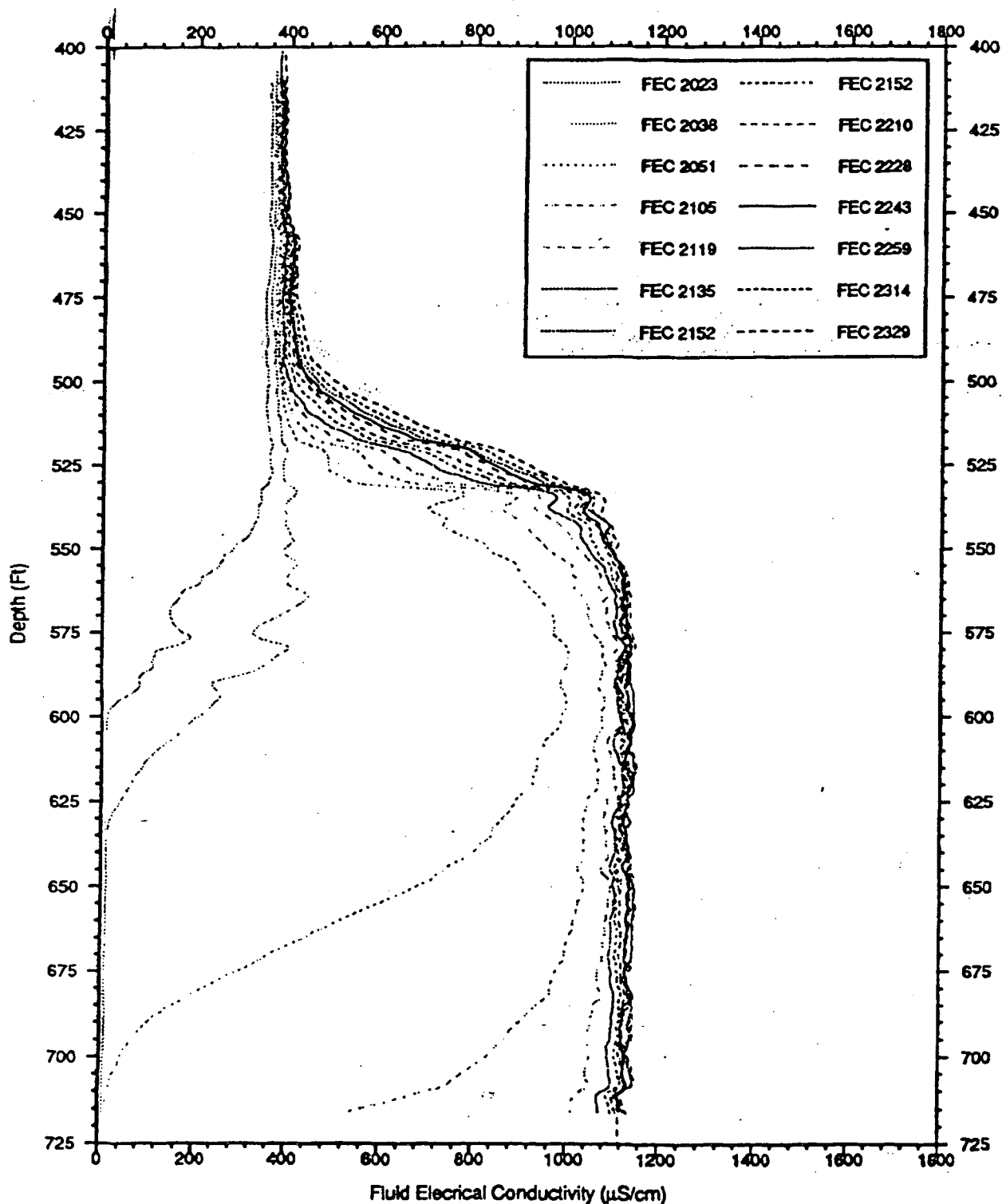

**Summary of HydroPhysical™ Logs for  
Ambient Flow Evaluation and Cross Hole Testing  
Well OB2-2**

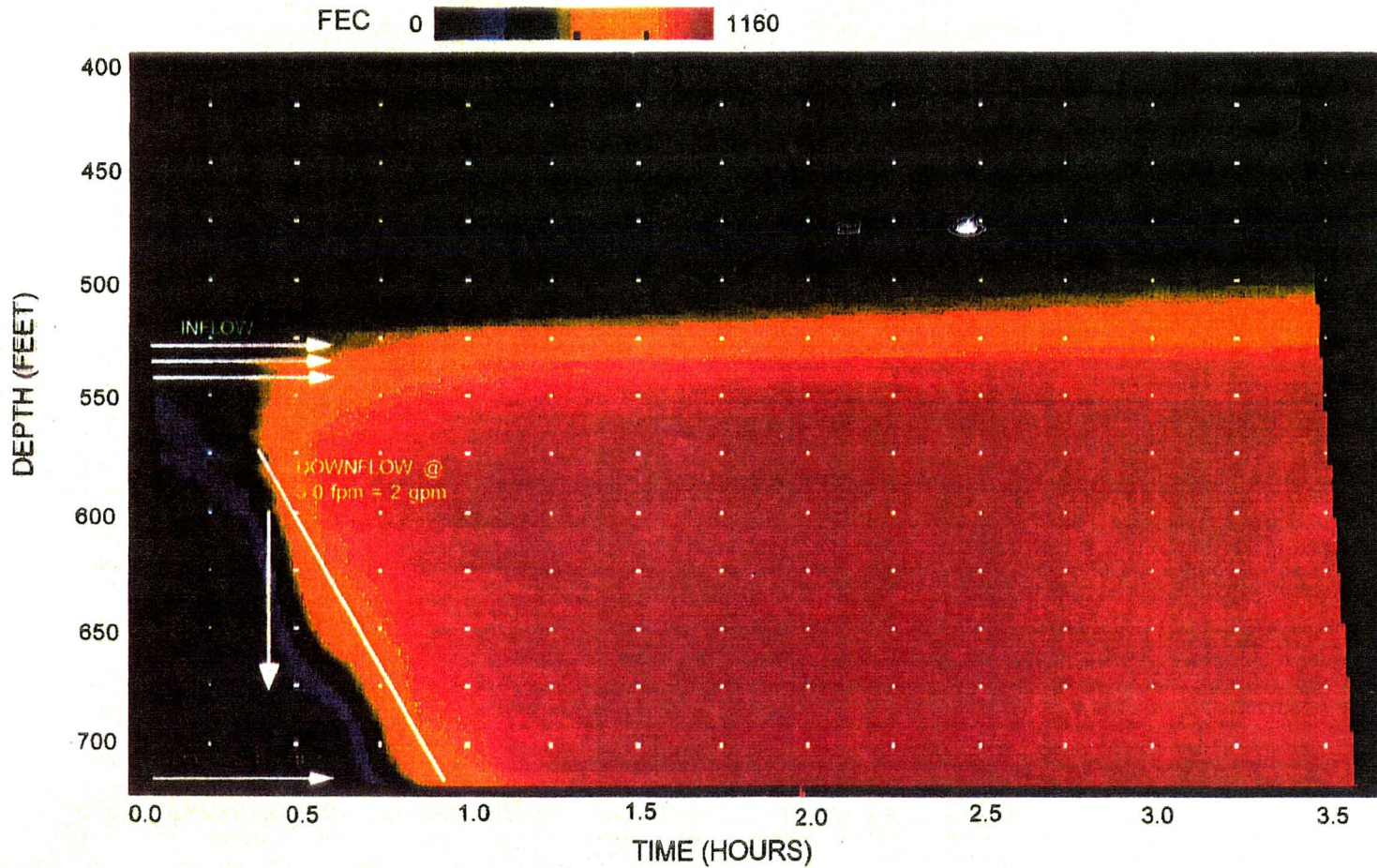



# BIBLIOGRAPHY

## for

### HYDROPHYSICAL LOGGING

Anderson, W.P., Evans, D.G., and Pedler, W.H., "Inferring Horizontal Flow in Fractures Using Borehole Fluid Electrical Conductivity Logs," EOS, Transactions of the American Geophysical Union Fall Meeting Vol. 74, No. 43, pg. 305, Dec. 1993.

Beauheim, R.L., L.C. Meigs, and M.B. Kloska. 1995. "Evaluation of Conceptual Models of Flow and Transport Through a Fractured Dolomite: 1. Hydraulic Testing," Presented at the 1995 AGU Fall Meeting, San Francisco, CA, Dec. 11-15, 1995; abstract in Eos, Transactions, American Geophysical Union. Vol. 76, no. 46, F251

Beauheim, R.L., L.C. Meigs, and P.B. Davies. 1997. "Rationale for the H-19 and H-11 Tracer Tests at the WIPP Site," OECD Documents, Field Tracer Transport Experiments, Proceedings of the First GEOTRAP Workshop, Cologne, Germany, 28-30 August 1996. Paris, France: OECD NEA.

Evans, D.G., Anderson, W.P., and Tsang, C.F., "Borehole Fluid Experiments Near Salt Contamination Sites in Maine," Research Project conducted under U.S. Department of Energy, Environmental Restoration and Waste Management Young Faculty Award Program, 1992.

Evans, D.G., "Ordinary and Constrained Least Squares Inversion of Borehole Fluid Logs," EOS, Transactions of the American Geophysical Union Fall Meeting Vol. 74, No. 43, pg. 305, Dec. 1993.

Evans, David G. Inverting Fluid Conductivity Logs for Fracture Inflow Parameters, to appear in Water Resour. Res., 1995 (in press).

Evans, David G. and Gerald Janowitz, Determining groundwater velocities from borehole dilution experiments with diffusion in the wellbore, submitted to Water Resour. Res., Aug. 1995 (in revision).

Evans, D.G., C.B. Lane, F. Paillet and W.H. Pedler, Hydraulic characterization of fractures in the Piedmont of North Carolina using fluid conductivity and transient flow logging, Geol. Soc. Am. Programs and Abstracts, Southeastern Regional Meeting (1996).

Crowder, R.E., and Pedler, W.H., "Integration of Borehole Geophysical and Fluid Logging Methods for Fractured Bedrock Characterization," EOS, Transactions of the American Geophysical Union Fall Meeting Vol. 74, No. 43, pg. 567, Dec. 1993.

Hale, F.V. and Tsang, C.F., "A Code to Compute Borehole Fluid Conductivity Profiles with Multiple Feed Points," LBL-24928, Lawrence Berkeley Laboratory, University of

California, Berkeley, CA and NDC-8, NAGRA-DOE Cooperative Project, and NTB 88-21, Nagra, Baden, Switzerland, March 1988.

Kelley, V.A., Loew, S., Vorvornis, E., "Determination of Fracture Connections in a Granite from a Pilot Crosshole Fluid Logging Test", EOS, Transactions of the American Geophysical Union Fall Meeting, Vol. 72, No. 44, pg. 216, Dec. 1991.

Lane, Craig, Comparison of borehole testing techniques to characterize hydraulic properties of bedrock fractures, Raleigh, North Carolina. MS Thesis, Department of Marine, Earth and Atmospheric Sciences, North Carolina State University (1995).

Loew, S., Ehlers, F., Andrews, R., McNeish, J., Vomvoris, and Hufschmied, P., "Quantitative Analysis of Electrical Conductivity Logs in the Leuggern Borehole (Switzerland)," Transactions of 1988 American Geophysical Union, Vol. 69, No. 44, pg. 1172, 1988.

Loew, S. (Nagra), C.F. Tsang, F.V. Hale and P. Hufschmied (Nagra), "The application of moment methods to the analysis of fluid electrical conductivity logs in boreholes," LBL-28809, Lawrence Berkeley Laboratory, University of California, Berkeley, CA, and NDC-8, NAGRA-DOE Cooperative Project, Nagra, Baden, Switzerland, August 1990.

Long, J.C.S., E.L. Majer, K. Karaski, C.L. Carnahan, J.S. Jacobsen, K. Hestir, D. Billaux, J. Peterson, L.R. Myer, and C.F. Tsang, "The NAGRA-DOE cooperative research program," pp. 185-188, in Earth Sciences Division Annual Report 1987, LBL-24200, UC-403, Lawrence Berkeley Laboratory, University of California, Berkeley, CA, September 1988.

Paillet, F.L., Kay, R.Y., Yeskis, D., and Pedler, W.H., "Integrating Well Logs into a Multi-Scale Investigation of a Fractured Sedimentary Aquifer", *The Log Analyst*, pgs. 24-41, Jan.-Feb., 1993.

Pedler, W.H., and Urish, D.W., "Detection and Characterization of Hydraulically Conductive Fractures in a Borehole: The Emplacement Method," EOS, Transactions of the American Geophysical Union Fall Meeting Vol. 69, No. 44, pg. 1186, Dec. 1988.

Pedler, W.H., Barvenik, M., Gardner, G., and Urish, D.W., "Detection and Characterization of Hydraulically Conductive Fractures by Geophysical Logging after Fluid Emplacement," Proceedings of the Second Annual Hazardous Materials Management Conference/Central, pgs. 121-129, 1989.

Pedler, W.H., Barvenik, M.J., Tsang, C.F., Hale, F.V., "Determination of Bedrock Hydraulic Conductivity and Hydrochemistry Using a Wellbore Fluid Logging Method," Proceedings of the Fourth National Water Well Association's Outdoor Action Conference, Las Vegas, NV, May 14-17, 1990; reprint LBL-30713, Lawrence Berkeley Laboratory, University of California, Berkeley, CA.

Pedler, W.H., and Kennard, M., "Hydrophysical Logging: An Advanced Wellbore Technology for Hydrogeologic and Contaminant Characterization of Aquifers," Proceedings of the 1992 Joint Meeting of the Arizona Hydrological Society/ Commission on the Arizona Environment, Arizona Water 2000.

Pedler, W.H., Tsang C.F., and Hale, F.V., "A Wellbore Fluid Logging Method for Characterizing Bedrock Aquifers," pp. 64-66 in Earth Sciences Division Annual Report 1990, LBL 27900, UC-403, Lawrence Berkeley Laboratory, University of California, Berkeley, CA, June 1991.

Pedler, W.H., "A Wellbore Fluid Logging Method for Aquifer Characterization," EOS, Transactions of the American Geophysical Union Fall Meeting, Vol. 72, No. 44, pg. 216, December 1991.

Pedler, W.H., Head, C.L. and Williams, L.L., "Hydrophysical Logging: A New Wellbore Technology for Hydrogeologic and Contaminant Characterization of Aquifers," Proceedings of Sixth National Outdoor Action Conference, National Groundwater Association, May 11-13, 1992.

Pedler, W.H., "Evaluation of Interval Specific Flow and Pore Water Hydrochemistry in a High Yield Alluvial Production Well by the HydroPhysical™ Fluid Logging Method" EOS, Transactions of the American Geophysical Union Fall Meeting Vol. 74, No. 43, pg. 304, Dec. 1993.

Pedler, W.H., "Integrated Borehole Logging Methods for Wellhead Protection," Proceedings of the 36<sup>th</sup> Annual Association of Engineering Geologist Meeting, page 66, 1993

Pedler, W.H., Kennard, M., "HydroPhysical™ Logging at the WQARF Site; Payson, Arizona," Proceedings of the Arizona Hydrological Society Sixth Annual Symposium, 1993

Tsang, C.F. and P. Hufschmied, "A Borehole Fluid Conductivity Logging Method for Determination of Fracture Inflow Parameters," LBL-23096, Lawrence Berkeley Laboratory, University of California, Berkeley, CA October 1987, NDC-1, NAGRA-DOE Cooperative Project and NTB-88-13, NAGRA, Baden, Switzerland, January 1988. Note that this report has been superseded by Tsang, Hufschmied and Hale, 1989.

Tsang, C.F., F.V. Hale, and P. Hufschmied, "Determination of Fracture Inflow Parameters with a Borehole Fluid Conductivity Logging Method," Water Resources Research, vol. 26, no.4, pp. 561-578, April 1990 and LBL 24752, Lawrence Berkeley Laboratory, University of California, Berkeley, CA, and NDC-1, NAGRA, Baden, Switzerland, September 1989.

Tsang, C.F. and F.V. Hale, "A Direct Integral Method for the Analysis of Borehole Fluid Electrical Conductivity Logs to Determine Fracture Inflow Parameters," pp. 108-110 in Earth Sciences Division Annual Report 1988, LBL-26362, UC-403, Lawrence Berkeley Laboratory, University of California, Berkeley, CA, August 1989.

Tsang, C.F. and F.V. Hale, "A Direct Integral Method for the Analysis of Borehole Fluid Conductivity Logs to Determine Fracture Inflow Parameters," in Proceedings, New Field Techniques for Quantifying the Physical and Chemical Properties of Heterogeneous Aquifers Conference, Dallas, Texas, March 20-23, 1989, F.J. Molz, ed., National Water Well Association, Dublin, OH.

Tsang, C.F., F.V. Hale, and P. Hufschmied, "Validation of a Method for Analyzing Borehole Fluid Conductivity Logs to Determine Fracture Inflow Parameters," pp/95-98 in Earth Sciences Division Annual Report 1989, LBL 27900, UC-403, Lawrence Berkeley Laboratory, University of California, Berkeley, CA June 1990.

Vernon, J.H, Paillet, F.L., Pedler, W.H., Moore, B.A., and Griswold, W.J., "Fracture Flow Assessment for Wellhead Protection Monitoring" *Groundwater*, in press, early 1996.

Vernon, J.H, Pedler, W.H., and Paillet, F.L., "Selected Borehole Geophysical Techniques for Well Protection in a Fractured Bedrock Aquifer", Special Environmental Edition, *The Log Analyst*, p. 41-58, Jan-Feb, 1993.

# **Mayak Site Characterization: Spatial Hydraulic Heterogeneity**

**Drozhko Eu. G.**

Production Association 'MAYAK'

**Samsonova L. M. and Vasil'kova N. I.**

P.S.A. Hydrospetzgeologia

**Pozdniakov S. P.**

Moscow State University

**Tsang C.-F.**

E. O. Lawrence Berkeley National Laboratory

July 8 - 9, 1997

## **JOINT RUSSIAN-AMERICAN HYDROGEOLOGY SEMINAR**

Russian - American Center for Contaminants Transport Studies

Ernest Orlando Lawrence Berkeley National Laboratory

Berkeley, California 94720

In general, the strategy of predictive modeling of flow and contaminant transport for the Lake Karachai area includes a) development of a regional two-dimensional flow model, in order to estimate the regional flow and its influence on contaminant spreading, and b) development of a local three-dimensional flow and contaminant transport model. Spatially, the local model is the subregion of the regional model, and the boundary conditions used for the local model are determined from the regional model. Therefore, as the first step, the spatial distribution of transmissivity averaged over thickness must be found for the regional flow model.

The total regional area of investigation, covering a zone of the shallow ground water system, is about 200 km<sup>2</sup>. During the last thirty years, many hydraulic well tests were performed here by different organizations, providing hydrogeological and engineering geological site characterization. These tests have a varying quality of available data, and our analysis shows that a hydraulic property averaged over the thickness of the aquifer, i.e., the transmissivity, can be found properly from this data. Over 30 years, about 300 wells were drilled within the territory. Well investigations include stratigraphic and structural interpretation (revealing fractured zones) hydraulic properties determination, telephotometry, resistivity logging, and other types of geophysical logs. All hydraulic tests conducted can be divided into the following types: a) single well pumping tests; b) injections into screened intervals of the well, or packer tests; and c) cluster pumping tests. The reliability of the information obtained by different types of tests varies. The data of cluster pumping tests are considered to be the most reliable.

All test data were divided into the categories "hard data" and "soft data." In the hard data set, the transmissivities are estimated reasonably precisely, and for the soft data set, just the specific discharges were measured correctly, or only these data were available. Therefore, the main difference between the hard and the soft data is the reliability of information for transmissivity estimation. In the hard data set, the transmissivities used

were determined directly from the test data. In the soft data set the transmissivities were calculated for the given specific discharges by using the equation determined from correlation between the discharge and the transmissivity.

From this selection, the total number of transmissivity values in the hard data set is 175 spatially distributed points, and in the soft data set, 100 points. The map of the areal distribution of these data is shown in Figure 1. This map shows that the spatial distribution of points with given transmissivity values is non-uniform. Thus, the highest density of tested points is between the lake Karahai and the bank of the Mishelyak River, on the contaminant flow path from the lake. The lowest density of points is in areas away from the lake; however, the probability of contaminants moving there is not significant.

For the estimation of anisotropy of the transmissivity field, the semivariograms for North - South, West-East and for all directions were calculated, using GSLIB subroutines. It was assumed that the main anisotropy axis coincides with the North - South direction, appropriate to the main tectonic alignment of the Urals region. According to the results shown in Figure 2, the empirical semivariograms for the orthogonal directions practically do not differ from each other, nor from the semivariogram calculated taking into account all data for all directions. The semivariogram for all directions was fitted by a theoretical curve  $Var(h)$ , that is the sum of the following components: nugget effect and exponential micro-scale and large-scale semivariograms:

$$Var(h) = \sigma_e^2 + \sigma_m^2[1 - \exp(-h / \lambda_m)] + \sigma_l^2[1 - \exp(-h / \lambda_l)] \quad (1)$$

where  $\sigma_m^2$  and  $\sigma_l^2$  are the scales of variation and  $\lambda_m$  and  $\lambda_l$  are the scales of correlation for the given exponential components.

As a result, the correlation scales determined are 100 and 625 meters. Therefore, the total correlation scale of transmissivity is of the order of seven hundred meters. This scale is

less than the characteristic scale of contaminant transport from Lake Karachi to the Misheliak river, approximately 2.5 km. About 30 % of transmissivity variability is the sum of the nugget effect and the small scale variation, with the spatial correlation scale of about one hundred meters. Such a character of the semivariogram demonstrates that the transmissivity field is "weakly" predicted by spatially distributed data, with average distances between points more than the first hundred meters.

The ordinary kriging of logarithms of transmissivity was used to create a map of expected transmissivity values. The hard and the soft data were used together in the data set for kriging interpolation, with the theoretical semivariogram described by eq. (1) containing the parameter values shown in Figure 2. The kriging results are shown in Figures. 3 and 4. Figure 5 illustrates the standard errors of kriging-interpolation. This figure also shows the poor predictivity of the transmissivity field.



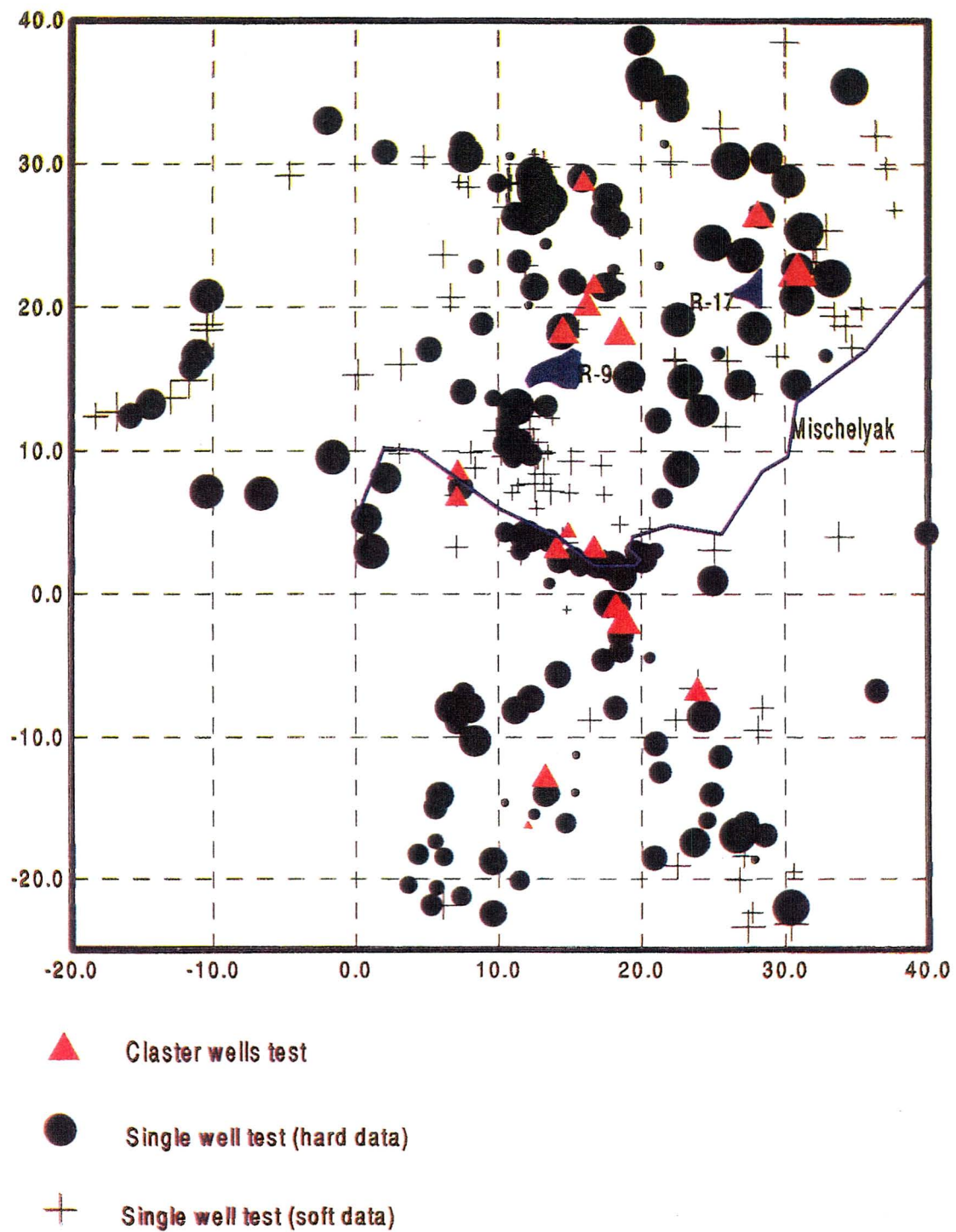

Fig. 1 The map of test points location. The symbols were scaled proportionally to log transmissivity estimated in this point.

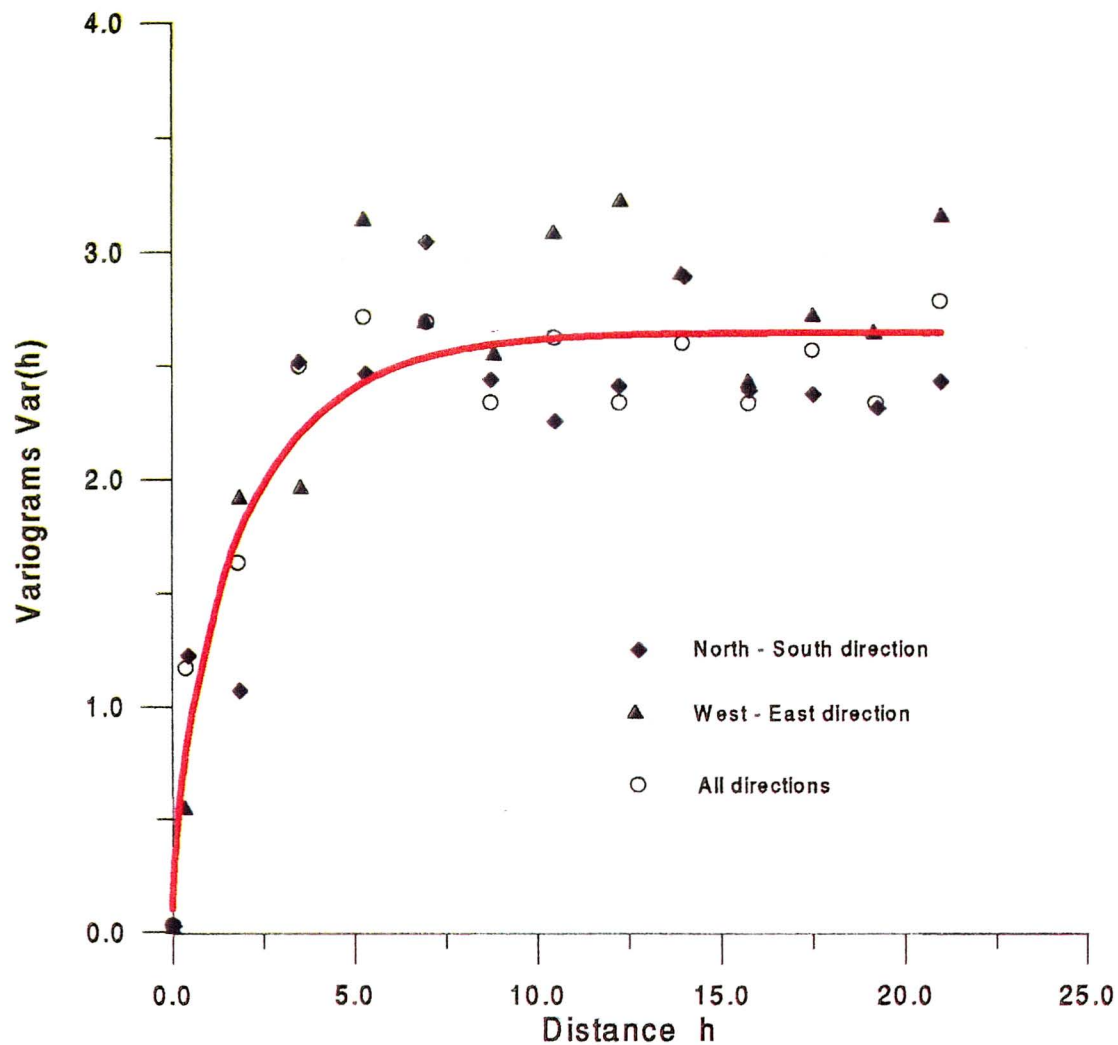

Fig. 2 Empirical variograms  $Var(h)$  of log transmissivity. Curve is fitting of the empirical variogram for all directions by the sum of nugget effect and exponential micro-scale and large-scale components:

$$Var(h) = \sigma_e^2 + \sigma_m^2[1 - \exp(-h / L_m)] + \sigma_l^2[1 - \exp(-h / L_l)]$$

with parameters:  $\sigma_{es}^2 = 0.1$ ;  $\sigma_m^2 = 0.7$ ;  $L_m = 0.4$ ;  $\sigma_l^2 = 1.85$ ;  $L_l = 2.5$

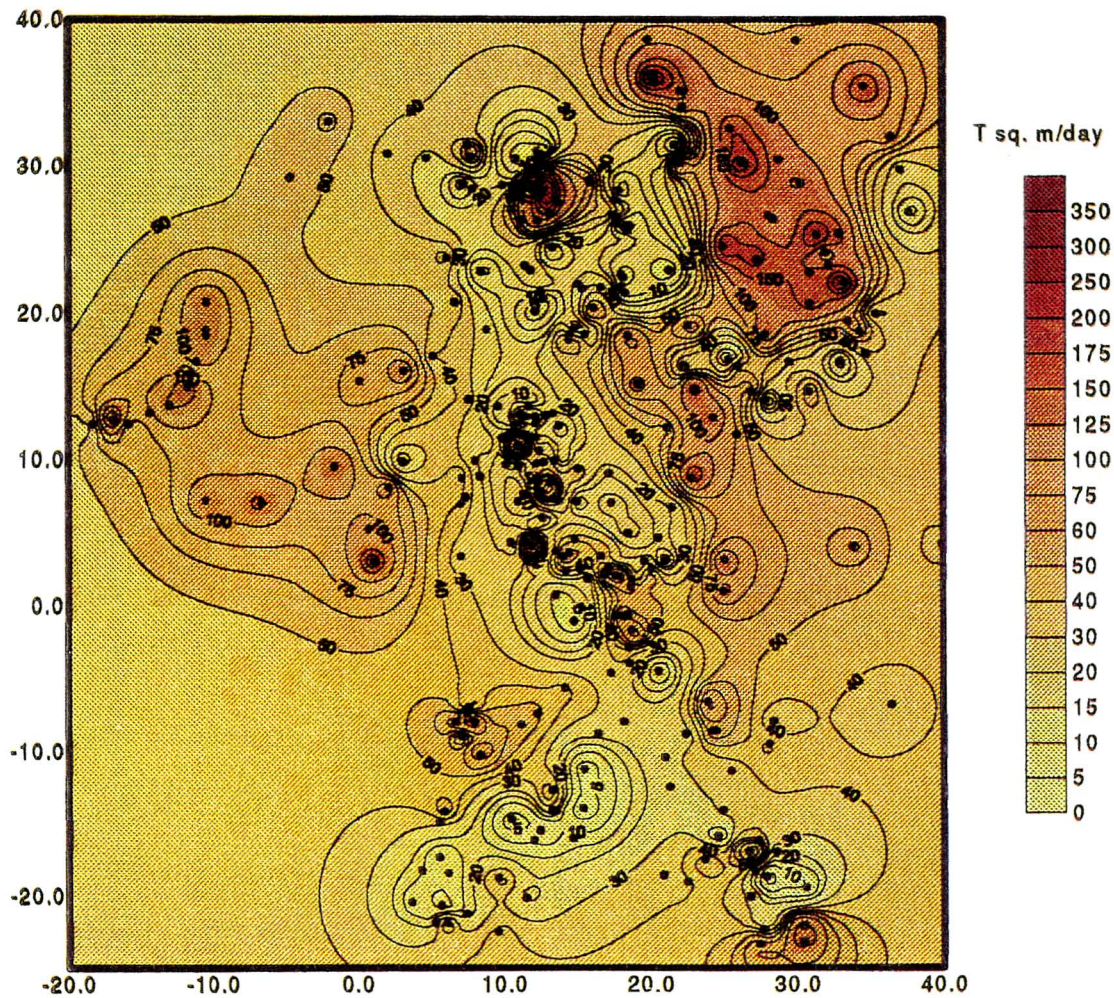

Fig. 3 The map of transmissivity estimated by ordinary kriging of transformed data with exponential variogram. The simple search for all hard and soft data was used for kriging interpolation.

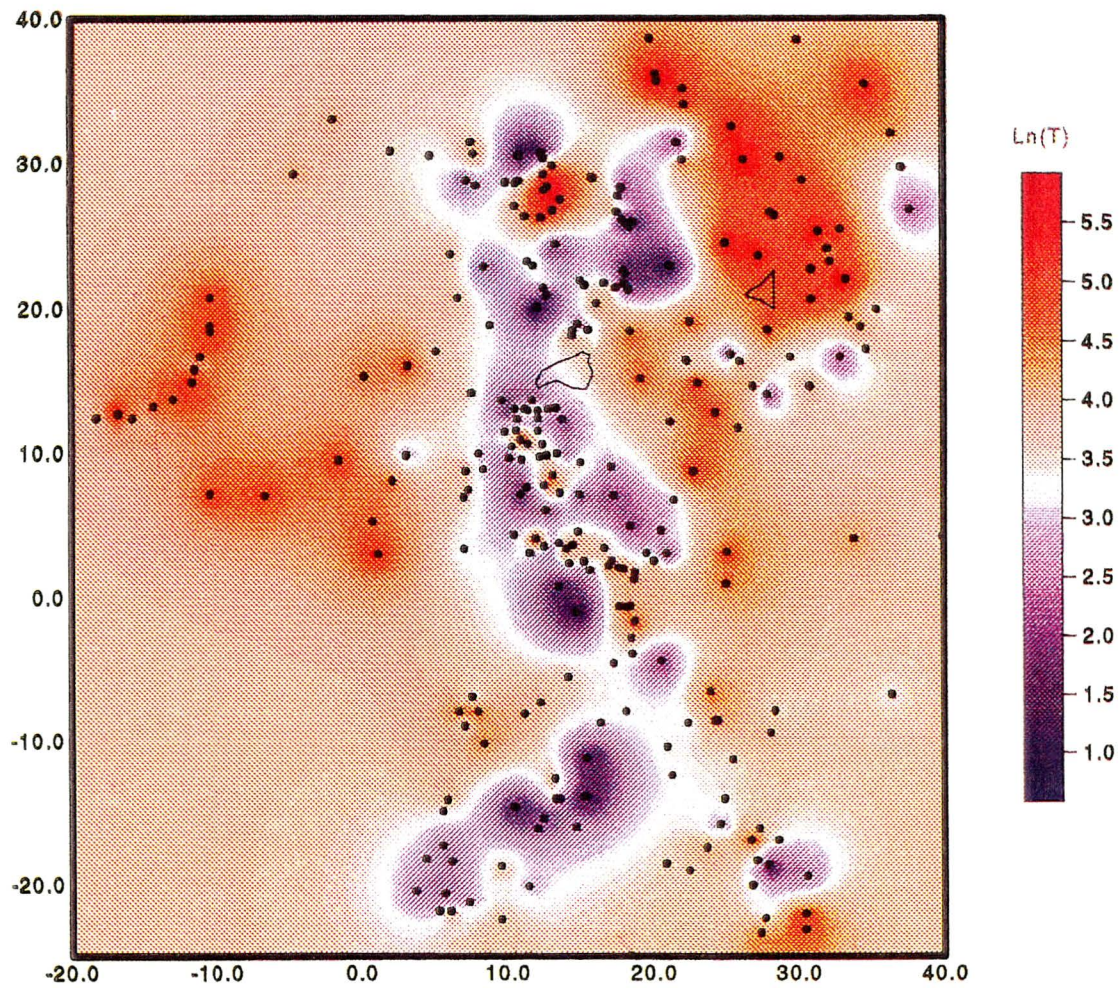

Fig. 4 Image of Log Transmissivity calculated by ordinary kriging. The black solid circulars are points of well with estimated transmissivity (all data).

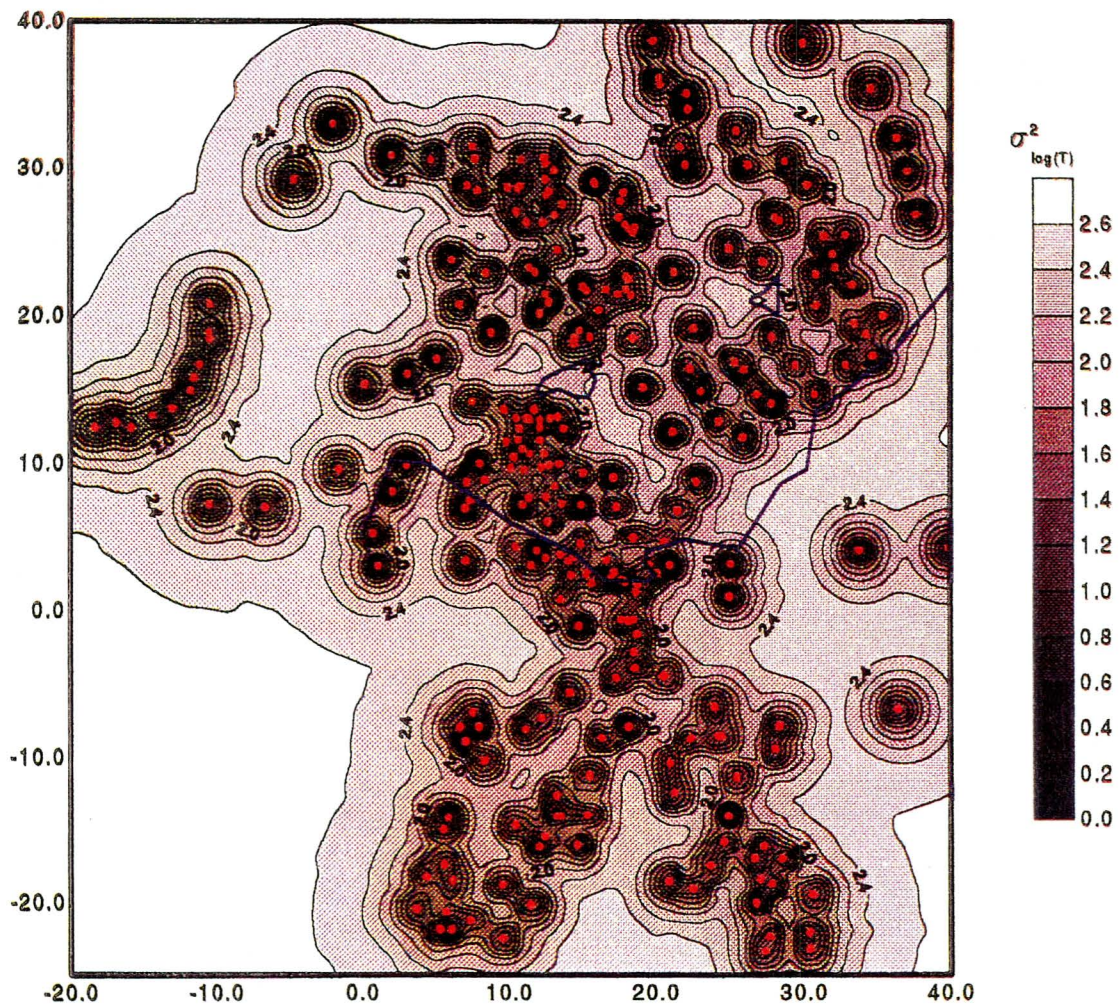

Fig. 5 The map of conditional variation of Log Transmissivity estimated by kriging. The red circulars are the points of well locations.

# **Neuro-Statistical Method for Contaminant Site**

**Masoud Nikraves**  
E. O. Lawrence Berkeley National Laboratory

July 8 - 9, 1997

## **JOINT RUSSIAN-AMERICAN HYDROGEOLOGY SEMINAR**

Russian - American Center for Contaminants Transport Studies  
Ernest Orlando Lawrence Berkeley National Laboratory  
Berkeley, California 94720

# Conceptual Modeling

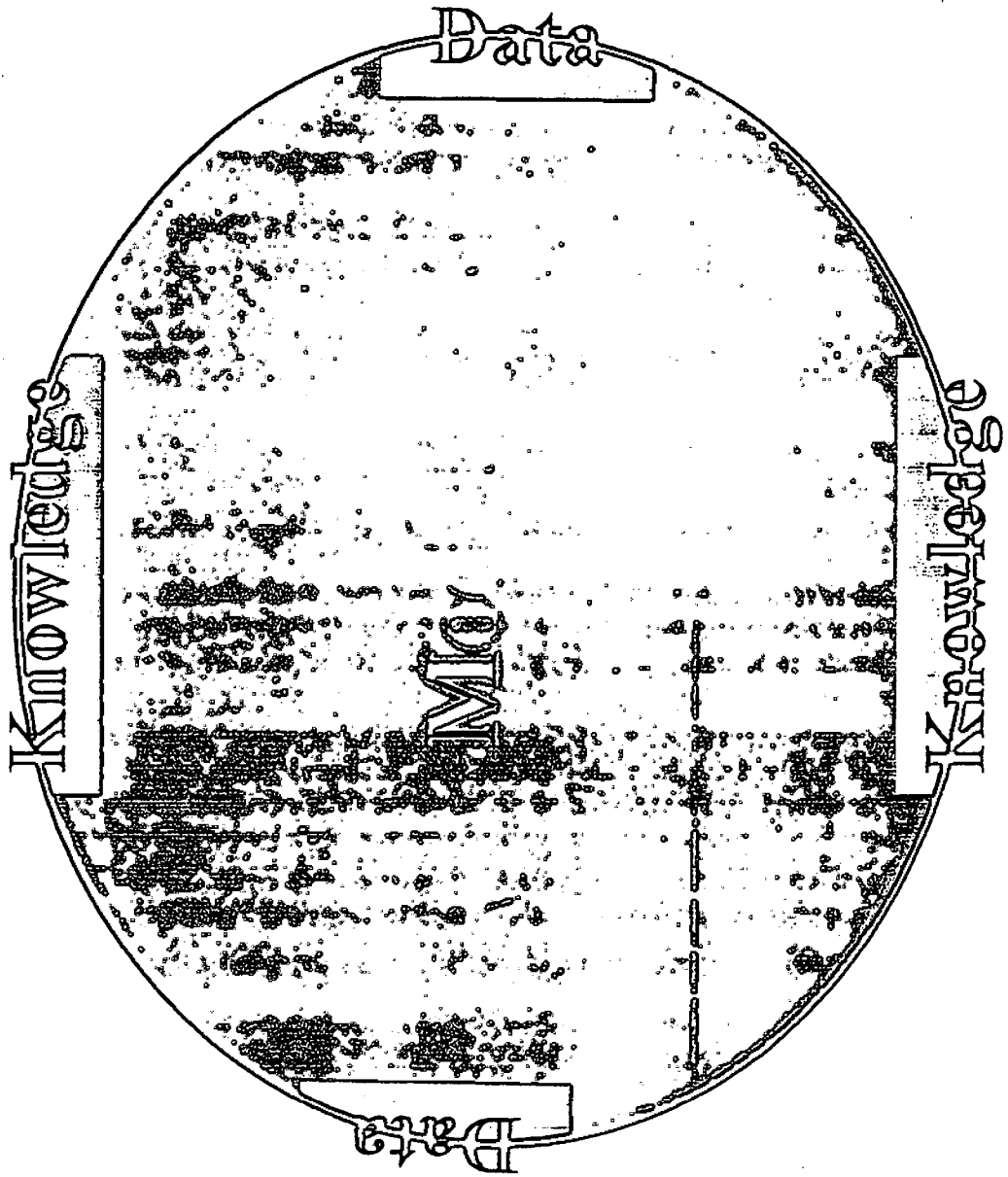

# Global Focus: Environmental Problems

Highly nonlinear, complex and coupled

Multi-dimensional

Uncertain

Huge data sets

Limited human ability to understand, too  
many unknowns

History dependent

Multi-objectives

Often conflicting objectives



## Neural Network

During the last decade, application of the neural networks for modeling the complex multi-dimensional field data greatly increased. These widespread applications have been due to several attractive features of neural networks. For example, these models do not require specification of a structural relationship between input and output data and can extract and recognize underlying patterns, structures, and relationships between data. However, developing a proper neural network model that is an "accurate" representation of the data may be an arduous task which requires sufficient experience with the qualitative effects of the structural parameters of neural network models, scaling techniques for input-output data, and a minimum insight into the physical behavior of the model. In addition, neural network models are frequently complex, need a large number of precise data, and the underlying patterns and structure are not easily visible. Conventional neural networks are also not usually stable and their performances are seriously affected once subjected to long-term prediction. Also, unlike statistical methods, conventional neural network models can not deal with probability.

**Neuro-Statistical Model:** In a model-based control of fluid injection into low permeability, it is of great importance to characterize how the injection pressure is related to injection flow rate based on historical data. However, data from injectors are often difficult to analyze due to their complexity, uncertainty, and the fact that a physical relationship cannot be established to show how the data are correlated. In addition, analysis of these data is laborious and human ability is limited in its understanding and use of the information. Unfortunately, only linear and simple nonlinear information can be extracted from these data by powerful tools of statistical methods such as ordinary Least-Squares (LS), Partial Least-Squares (PLS.), and nonlinear Quadratic Partial Least-Squares (QPLS). However, if priori information regarding the nonlinear input-output mapping is available, these methods become more useful. In regards to mathematical modeling, simple models may become inaccurate as several assumptions are made to simplify the models in order to solve the problem mathematically. On the other hand, complex models may become inaccurate when additional equations involving a more or less approximate description of phenomena are included in the model. In most cases, these models require a number of parameters which are not physically measurable. As a third alternative, the Neural Network-Statistical Model (NSM or Neuro-Statistical Model) provide the potential to establish a model from nonlinear, complex, multi-dimensional, uncertain, and imperfect data. The model uses the advantage of the neural network in conjunction with statistical methods to analyze the data and identify the model based on data. The model uses neural network techniques, since the functional structure of the data is unknown. In addition, the model uses statistical techniques because the data and our requirements are imperfect. Statistical techniques are considered to be appropriate to deal with the nature of uncertainty in system and human error, which are not included in current neural network models. Using the nonlinear statistical techniques, we developed a neural network model in which the network parameters reflect the uncertainty in the output data. In this case, instead of one value for each network parameter, a distribution of values has been assigned to the network parameters. Therefore, the neural network prediction will be a distribution rather than a crisp value. The model has been compared with conventional neural network models. It has been concluded that the most probable parameter for the new model is similar to the crisp value for the conventional model. Using this concept the conventional Levenberge-Marquardt algorithm is modified. In this case, the final global error in the output at each sampling time is related to the network parameters and a modified version of the learning coefficient is defined. The following equations briefly shows the difference between conventional and modified technique. In the conventional technique weights can be calculated by,

$$\Delta W = (\underline{J}^T \underline{J} + \mu^2 \underline{I})^{-1} \underline{J}^T e \quad [1]$$

However, in modified technique the weights are given by,

$$\Delta W = (\underline{J}^T \underline{\Delta}^T \underline{\Delta} \underline{J} + \Gamma^T \Gamma)^{-1} \underline{J}^T \underline{\Delta}^T \underline{\Delta} e \quad [2]$$

$$\underline{\Delta}^T \underline{\Delta} = \hat{\underline{V}}^{-1} \quad [3]$$

Masoud Nikravesh, Joint Russian/American Hydrogeology Seminar, July 8-9, 1997, LBNL

$$\hat{V}_{ij} = \frac{1}{2m+1} \sum_{k=-m}^m \hat{e}_{i-k} \hat{e}_{j+k} \quad [4]$$

$$\hat{V} = \hat{\sigma}^2 \mathbf{I} \quad [5]$$

$$\hat{W} = W \pm k \hat{\sigma} \quad [6]$$

where  $e$  is error,  $k$  is gain,  $\sigma$  is variance,  $\Gamma$  is tuning parameter, and  $\mathbf{J}$  is Jacobian matrix.

Figure 1 shows the performance of the new network model. Figure 1.a shows the predictive performance of the network model. In Figure 1, circles represent actual data, crosses represent the mean of the neural network predictions, squares represent the upper limit (max.) of the network prediction and triangles represent the lower limit (min.) of the network prediction. Figure 1.a shows that the network has an excellent performance and also the actual value always lies between the upper and the lower limit predicted by neural network. Figures 1.b, 1.c, and 1.d are a magnification of Figures 1.a, 1.b, and 1.c. As one can see the trend in Figure 1.b, 1.c, and 1.d is the same as the trend in Figure 1.a. As we mentioned earlier, the output from the network is a distribution rather than a crisp value. Figure 1.e shows the distribution of the predicted values. Referring to Figure 1.e and 1.f, one can see that actual value is bounded between the one standard deviation from the most probable value. Figures 1.f, 1.g, and 1.h show the comparison between actual data, the most probable prediction based on the neural network, upper limit, lower limit, and one standard deviation from the most probable prediction. Using this technique the upper and lower bound tightened.

Even though the Levenberge-Marquardt algorithm is faster and more robust than the conventional algorithm, but it requires more memory. Therefore, to overcome this disadvantage we need to reduce the complexity of the neural network model and/or reduce the number of the data points used in each step of training. In the former case, we will use the Alternative Conditional Expectation (ACE) technique [3], a non-parametric statistical technique, to reduce the network structure. This will be done by extracting the patterns which exist in the data (Figures 2.a, 2.b, 2.d, and 2.e). In the next section, we will introduce the idea very briefly. To reduce the data points used in each step of training, we will divide the data-sets into several sub-data sets based on the pattern extracted (Figures 2.b and 2.e) using the ACE technique. In this case, we will use the recursive technique [2, 8] for network training and then use the modified Levenberge-Marquardt algorithm. Therefore, the final global error in the output at each sampling time is related to the network parameters and a modified version of the learning coefficient is defined.

**Hybrid Neural Network-Alternative Conditional Expectation (HNACE):** Recently, application of the non-parametric statistical method such as the Alternative Conditional Expectation (ACE) scheme for modeling the complex multi-dimensional field data has greatly increased. Statistical techniques such as ACE are considered to be appropriate to deal with the nature of uncertainty. In addition, the underlying patterns and structures recognized by ACE are more visible than neural network structure (Figures 2.b and 2.e). The ACE method is a statistical technique which can be used to find optimal transformation that maximizes the correlation between the transformed variables in a reduced and normally distributed space (Figures 2.c and 2.f). Therefore, since the ACE technique transformed the variables into a scaled domain in an optimal fashion, this technique can be used for scaling the input-output data for neural network structure (Figures 2.c and 2.f). In addition, since this technique can find the correlation between the variables, it can be used to reduce the complexity of the network structure by eliminating the variables which do not introduce any new information into the network model and more knowledge into the network model (Figures 2.g, 2.h and 2.i). This can be done by examining the transformed variables (Figures 2.b, 2.e and 2.h).

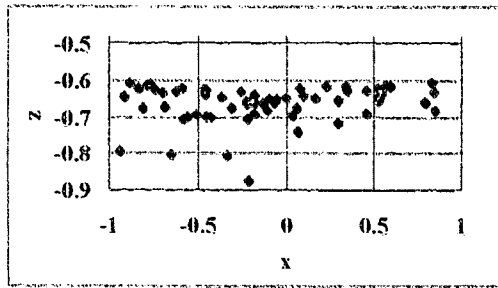

Figure 2.a. Actual Data

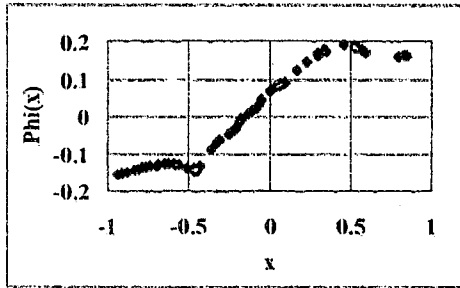

Figure 2.b. Underlying Pattern

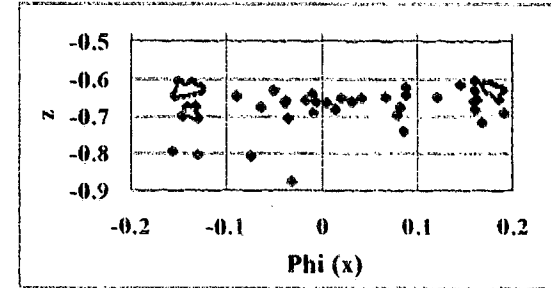

Figure 2.c. Transformed Space

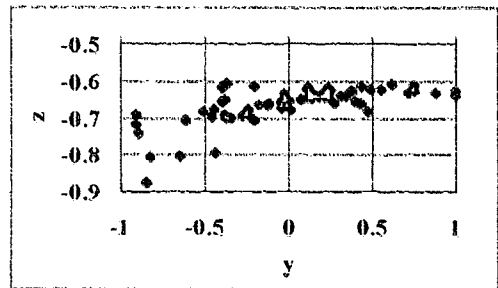

Figure 2.d. Actual Data

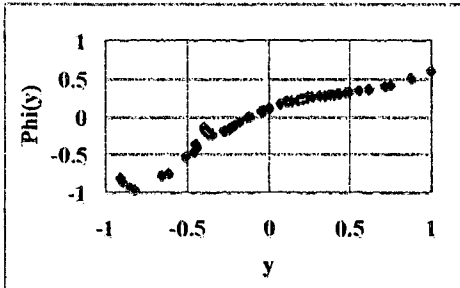

Figure 2.e. Underlying Pattern

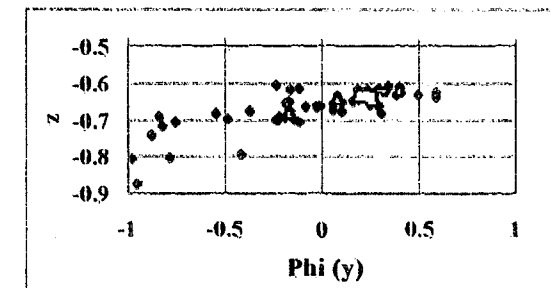

Figure 2.f. Transformed Space

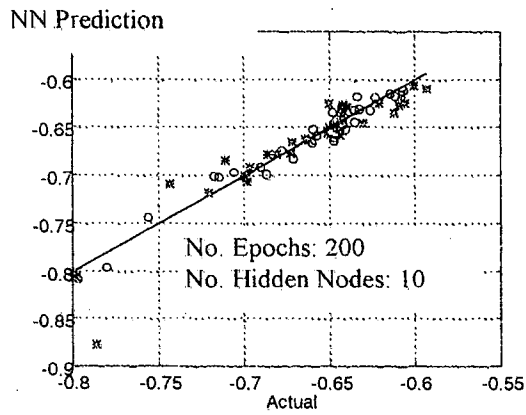

Figure 2.g. Performance of Conventional Neural Network

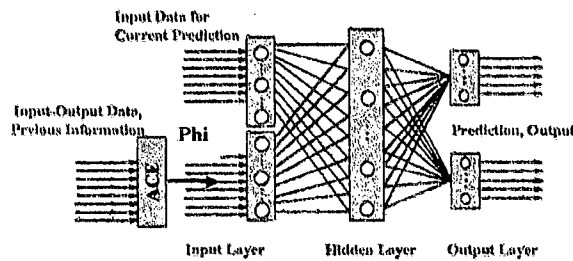

Figure 2.h. Hybrid ACE Model

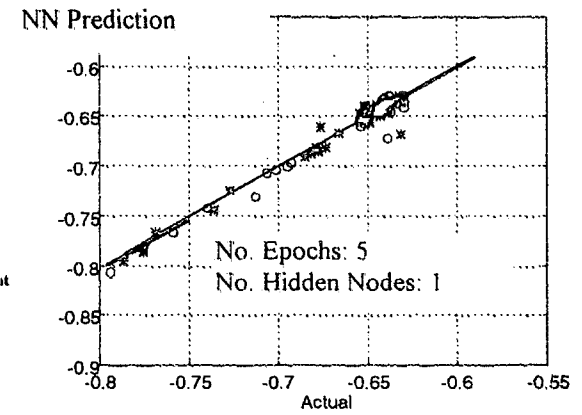

Figure 2.i. Performance of ACE-Neural Network

Figure 2. ACE, Neural Network, and ACE-Neural Network Models and Performances

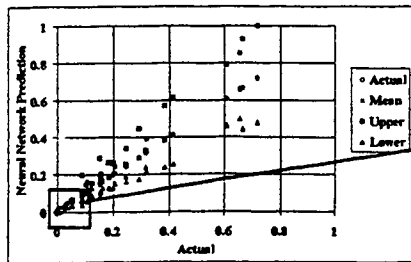

Figure 1.a.

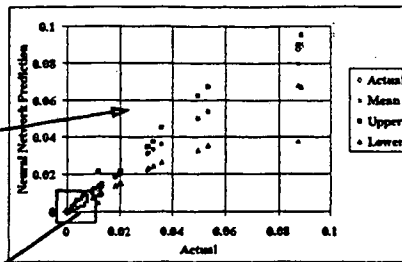

Figure 1.b.

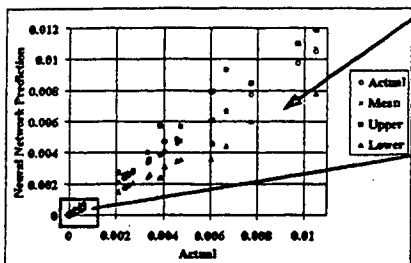

Figure 1.c.

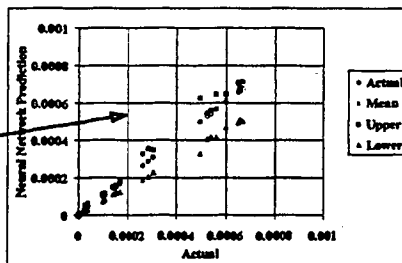

Figure 1.d.

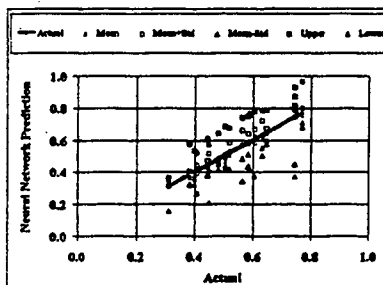

Figure 1.e.

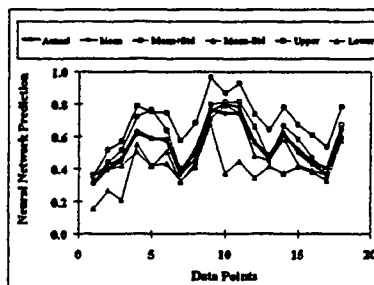

Figure 1.f.

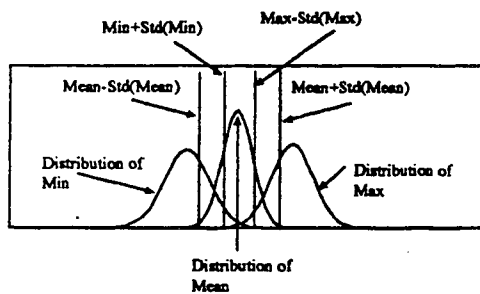

Figure 1.g.

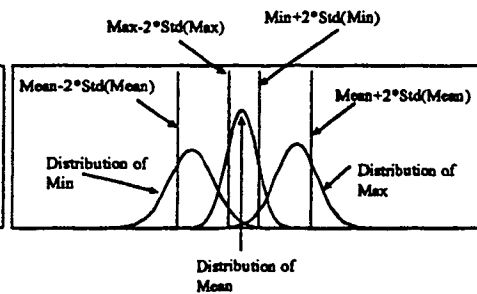
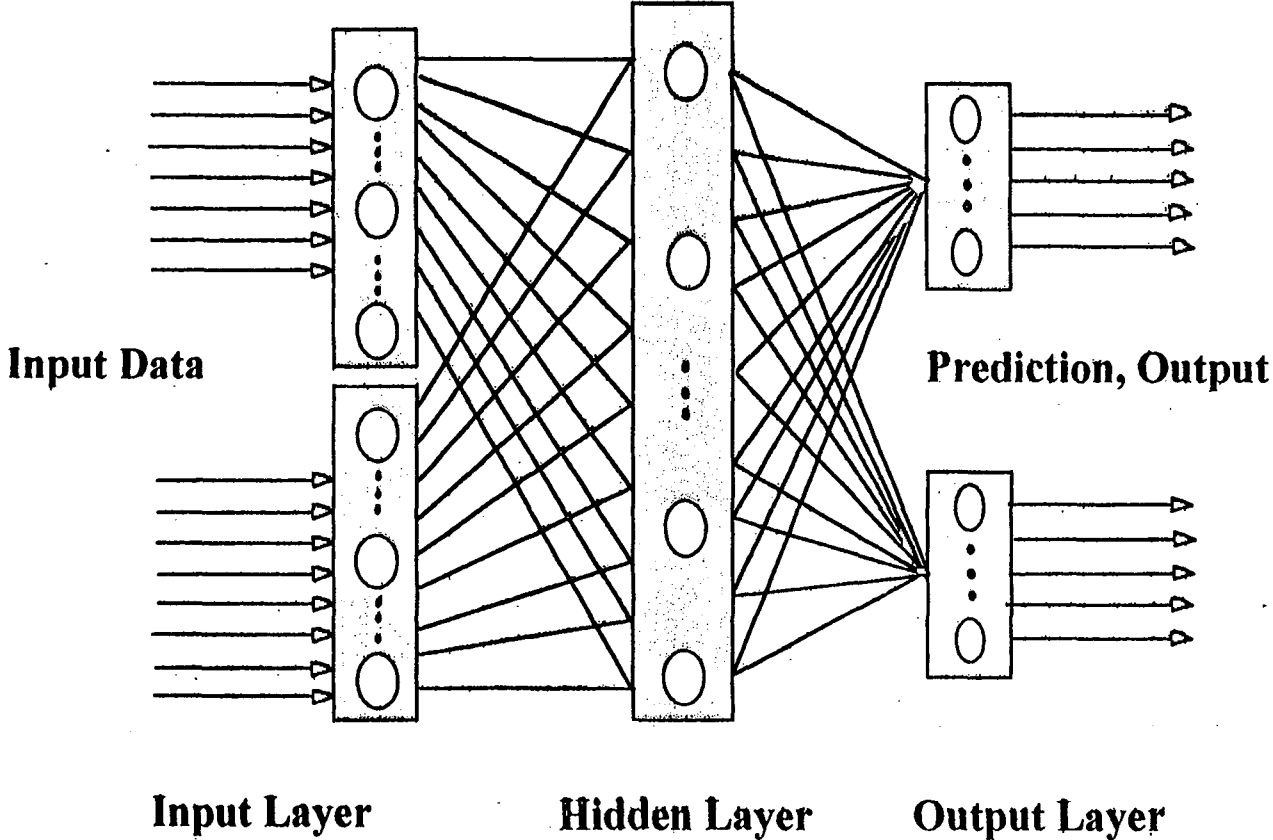

Figure 1.h.

Figure 1. Performance of the Neuro-Statistical Model

Masoud Nikravesh, Joint Russian/American Hydrogeology Seminar, July 8-9, 1997, LBNL

# Typical Neural Network Structure



## Neuro-Statistical Method for Contaminant Site

In a contaminated site, it is of great importance to characterize how the contaminants move and spread. However, data from contaminants sites are often difficult to analyze due to their complexity and the fact that a physical relationship cannot be established to show how the data are correlated. In addition, analysis of these data is laborious and human ability is limited in its understanding and use of the information.

Based on preliminary study, it has been concluded that it is very difficult to analyze field data from the contaminant site using linear models or conventional statistical models since no physical relationship exists between these data. On the other hand, the data in this site, in spite of the richness of information, is not enough for training a proper neural network model. Therefore, in this project, it was decided to use the advantage of the neural network in conjunction with statistical methods to analyze the data. The model uses neural network techniques, since the functional structure of the data is unknown. Neural networks, unlike regression analysis, do not require specification of structural relationships between the input and output data. In addition, the model uses statistical techniques because the data and our requirements are imperfect. Statistical techniques are considered to be appropriate to deal with the nature of uncertainty in system and human error, which are not included in current neural network models.

### **Following is the approach used in this study.**

1. Using the linear, cubic, cubic spline, and nearest neighbor techniques, the data has been interpolated and extrapolated around the actual data points. Using this technique, we were able to increase the number of data points by a factor of 10. The new data set and actual data set has been checked based on conventional statistical methods to insure that the new data has not seriously changed the original statistics. In addition, the new data has been tested for their relevance to the original data based on conventional statistical methods.

2. Using the nonlinear statistical techniques, we developed a neural network model in which the network parameters reflect the uncertainty in the output data. In this case, instead of one value for each network parameter, a distribution of values has been assigned to the network parameters. Therefore, the neural network prediction will be a distribution rather than a crisp value. Figures 1 through shows the performance of the developed neural network model.

M. Nikraves, Neuro-Statistical Approach, Section in the SPE 38275, 1997 and Section in "KNOWLEDGE DISCOVERY FROM DATA BASES: INTELLIGENT DATA MINING TECHNIQUE", FACT Inc. and LBNL Proposal, submitted to SBIR-NASA, 1997.

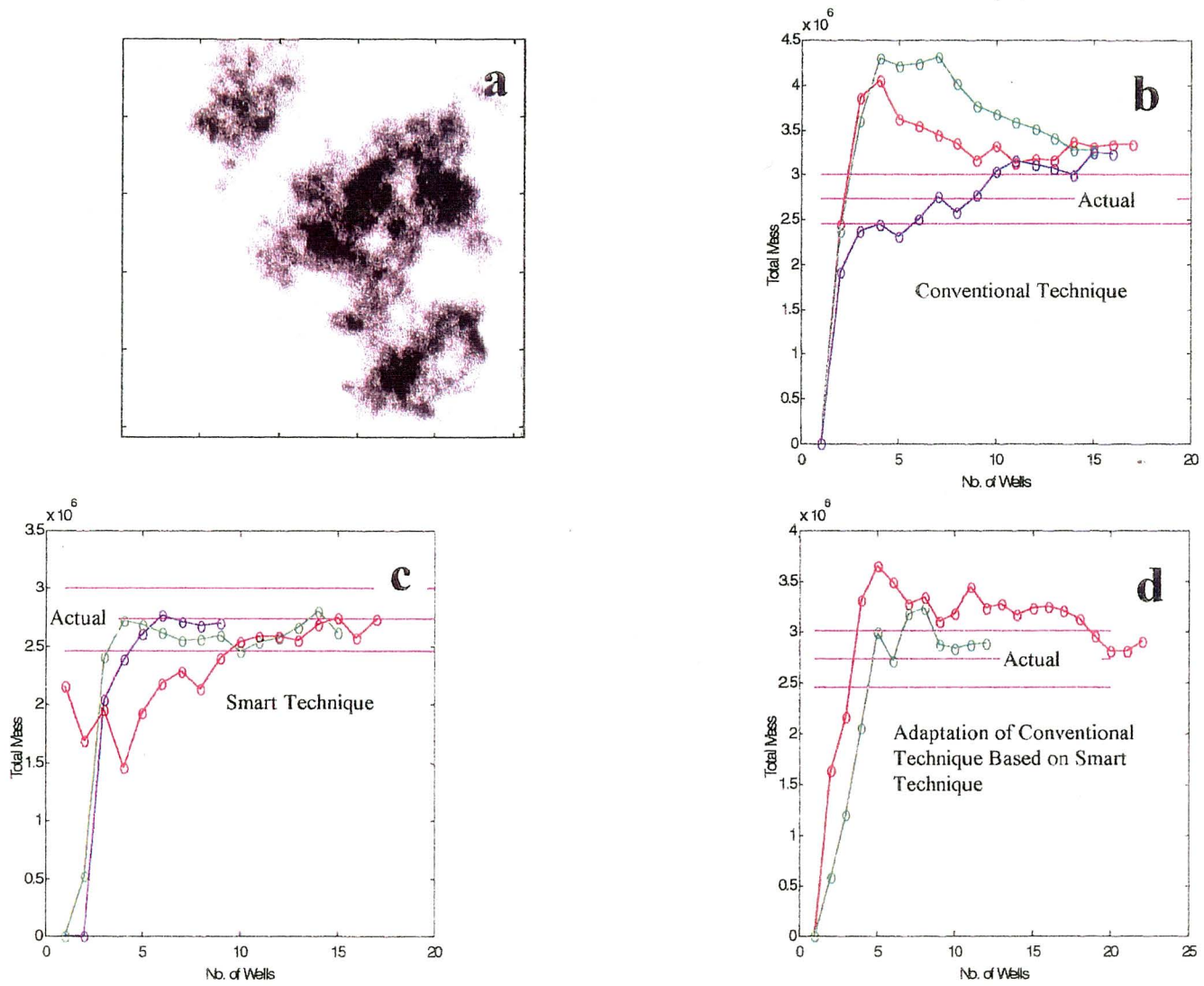
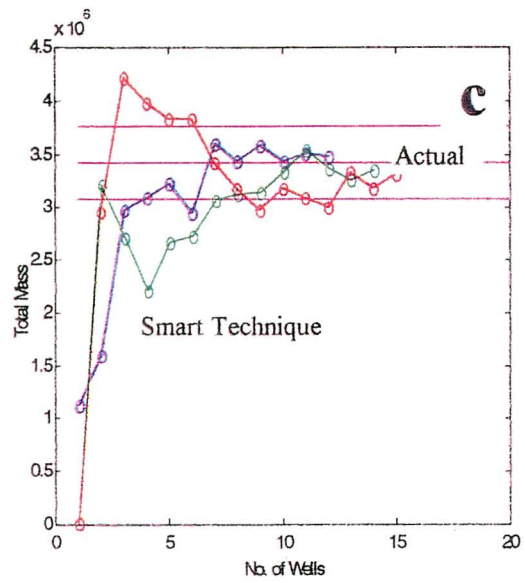
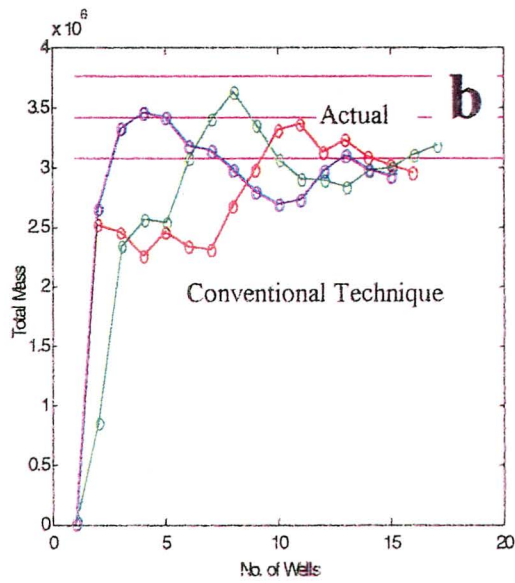
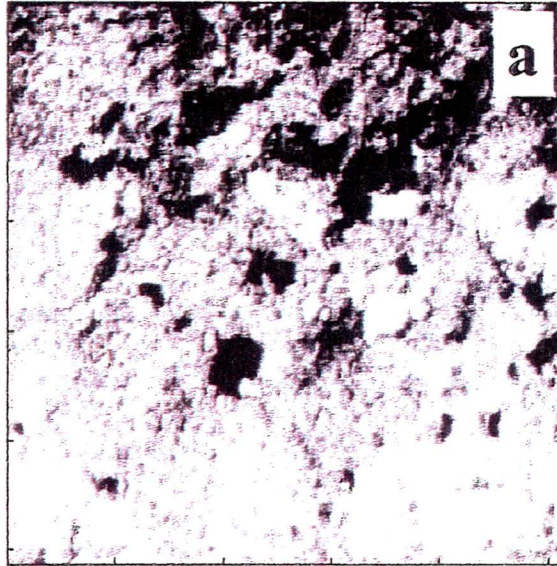
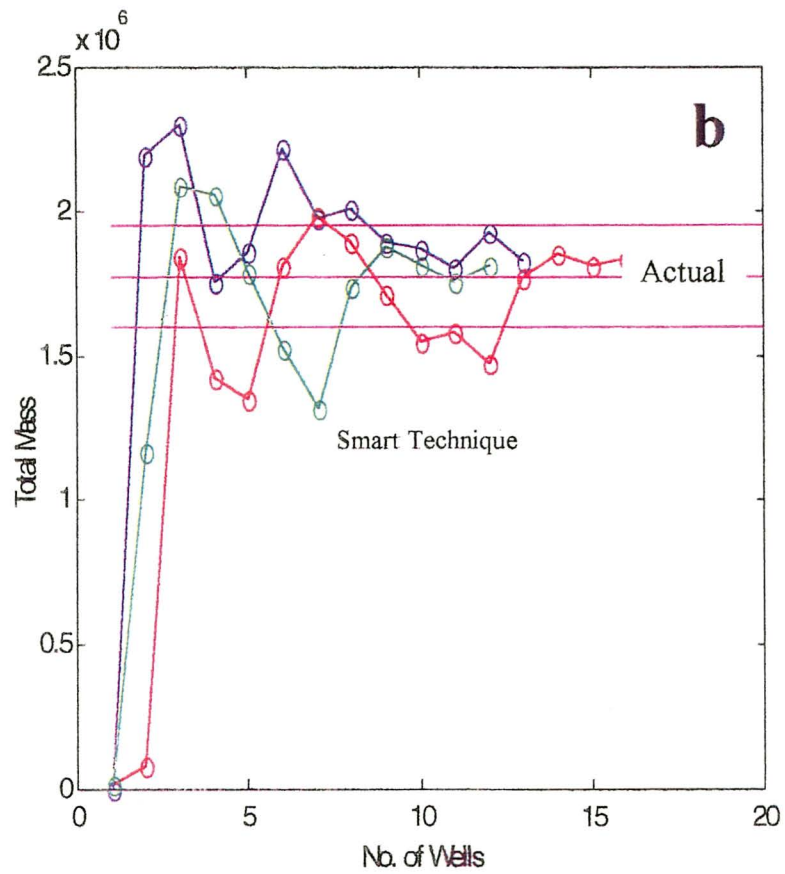
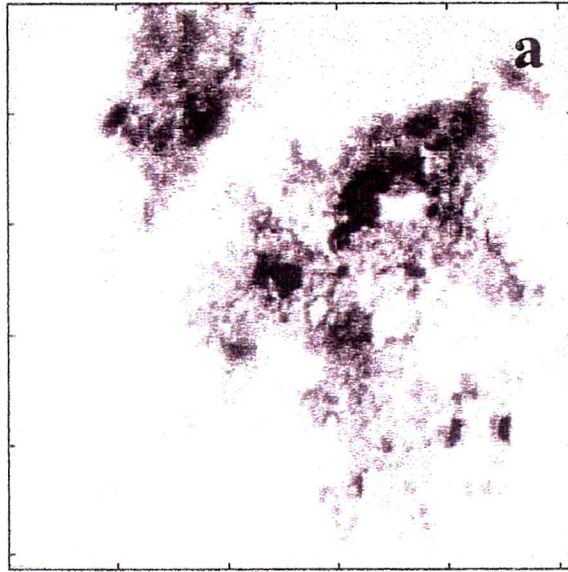

Figure 1. Calculation of Total Mass, Example 1.



**Figure 2. Calculation of Total Mass, Example 2.**





**Figure 3. Calculation of Total Mass, Example 3.**

Masoud Nikravesh, Joint Russian/American Hydrogeology Seminar, July 8-9, 1997, LBNL

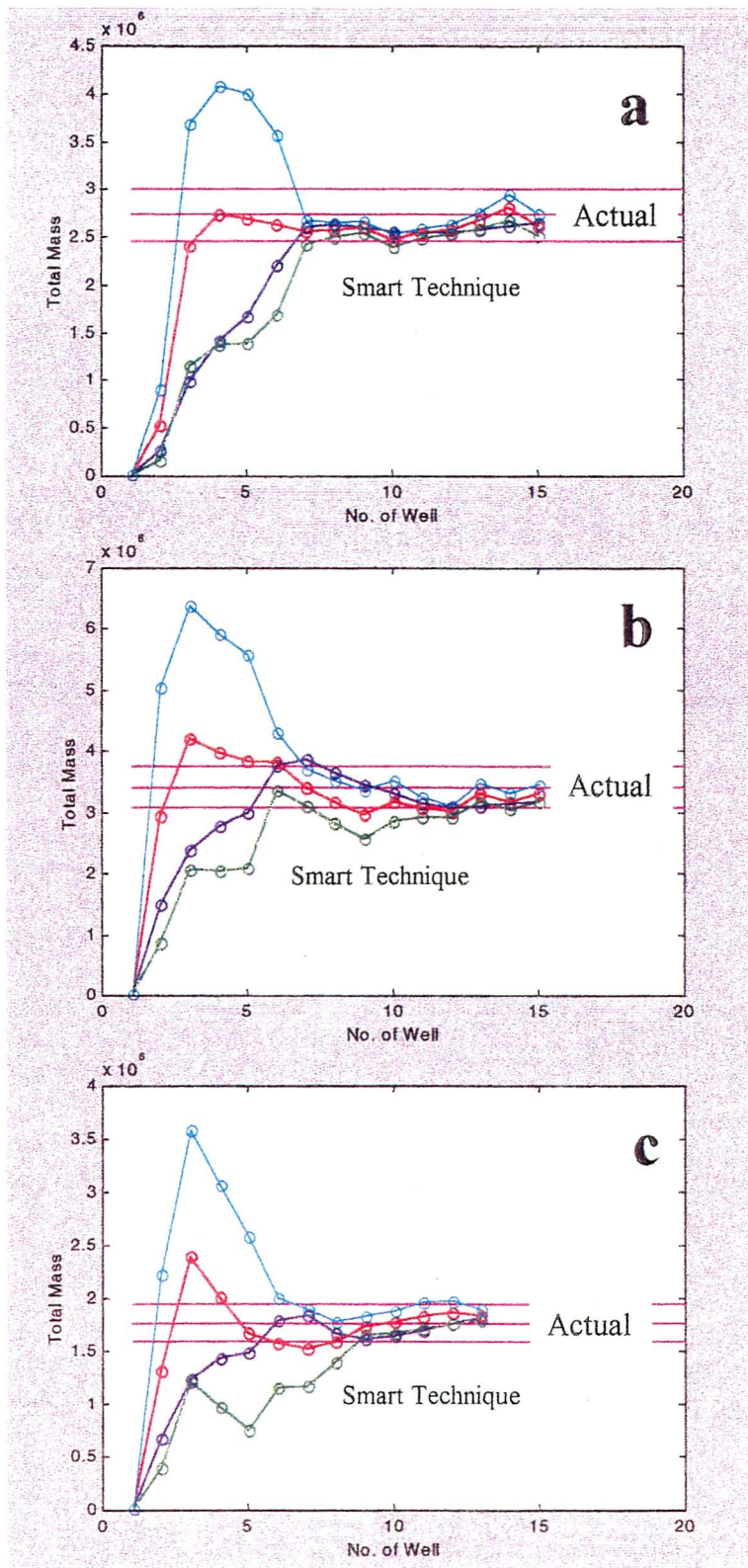
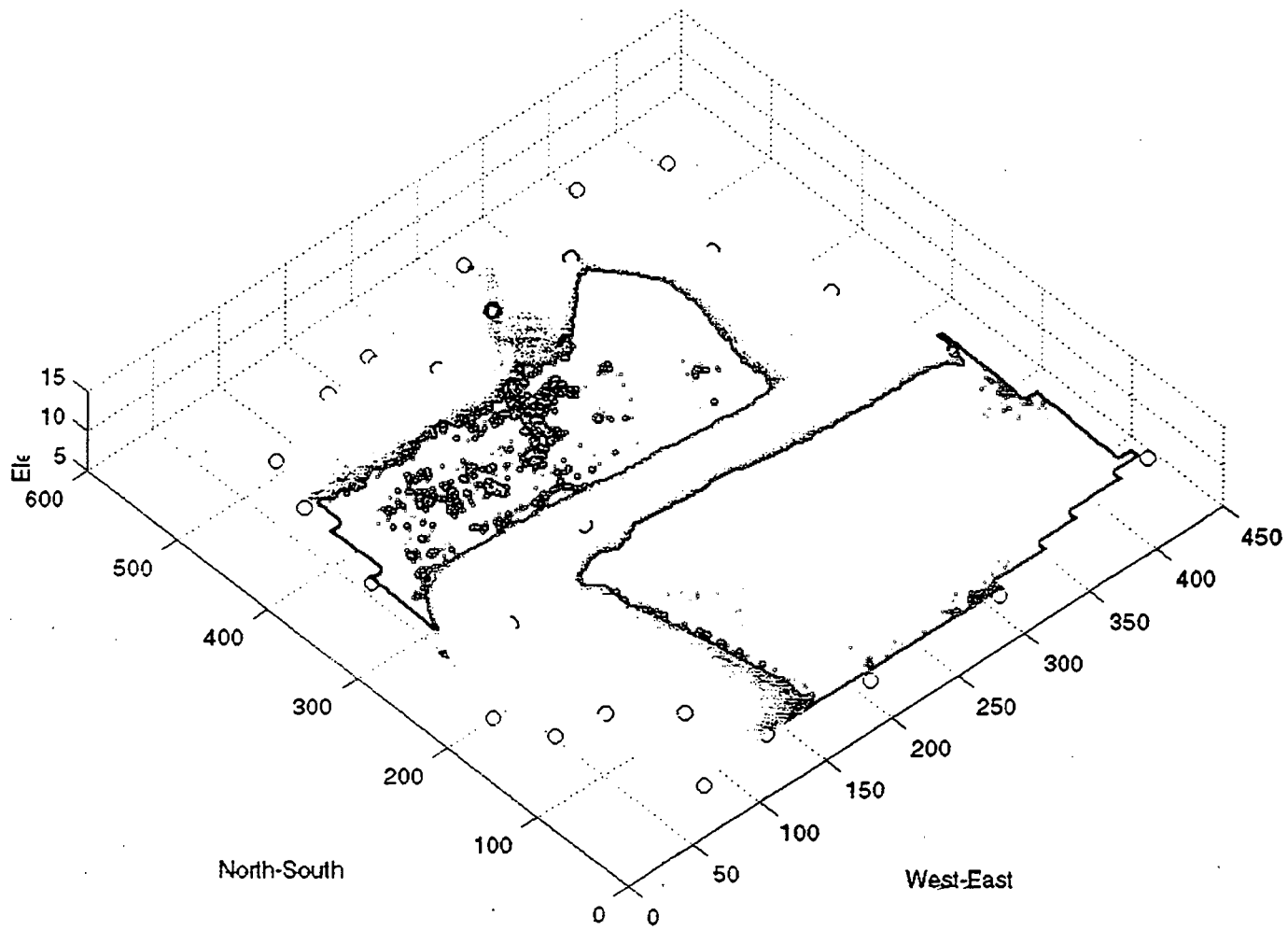

Figure 4. Calculation of Total Mass; Upper, Lower, Mean and the Most Probable; (a) Example 1, (b) Example 2, and (c) Example 3.

Masoud Nikraves, Joint Russian/American Hydrogeology Seminar, July 8-9, 1997, LBNL



z = 5 feet

326

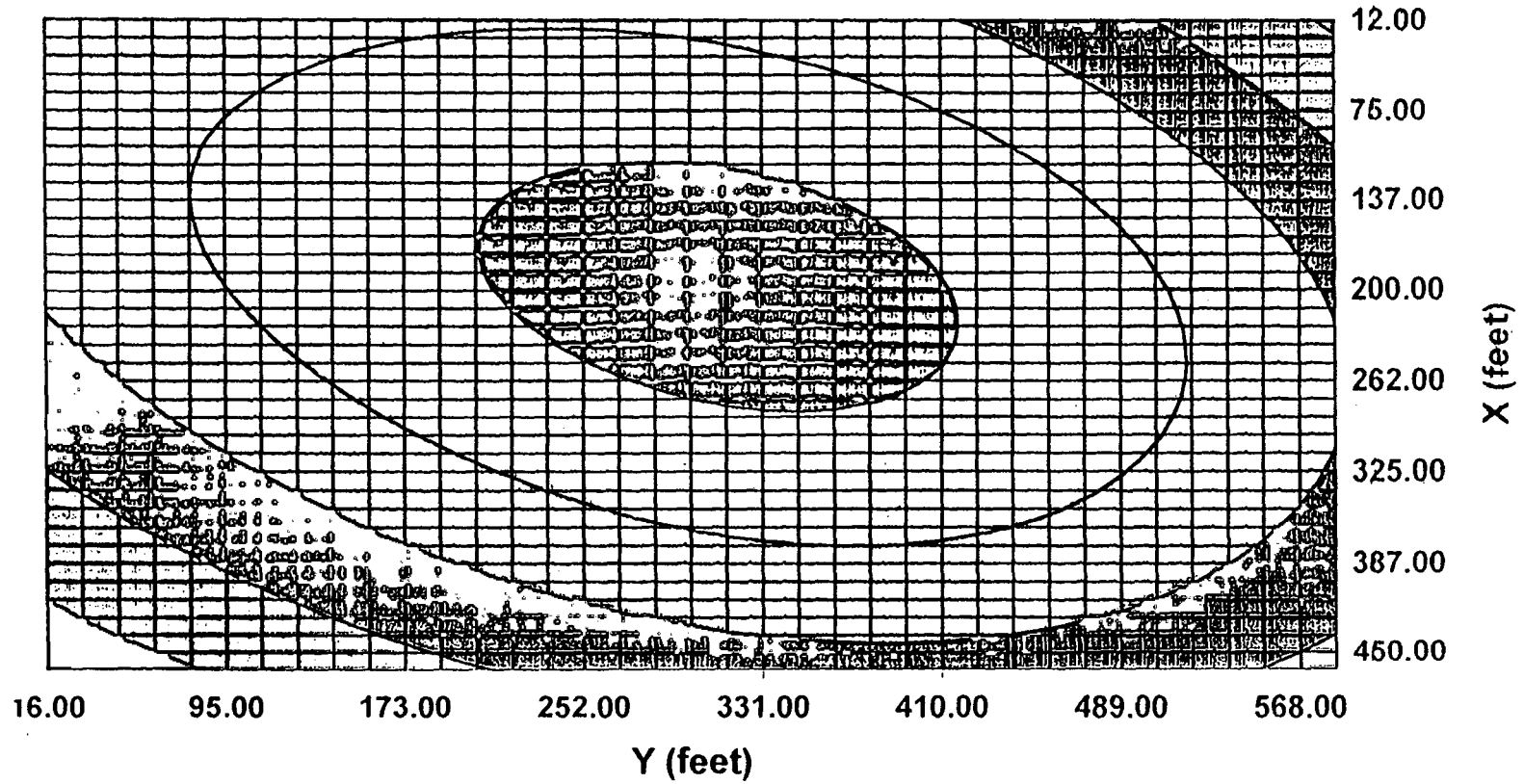

pH Color Code

■ 5.00-6.00 □ 6.00-7.00 □ 7.00-8.00 ■ 8.00-9.00 ■ 9.00-10.00 □ 10.00-11.00

Z = 5 feet

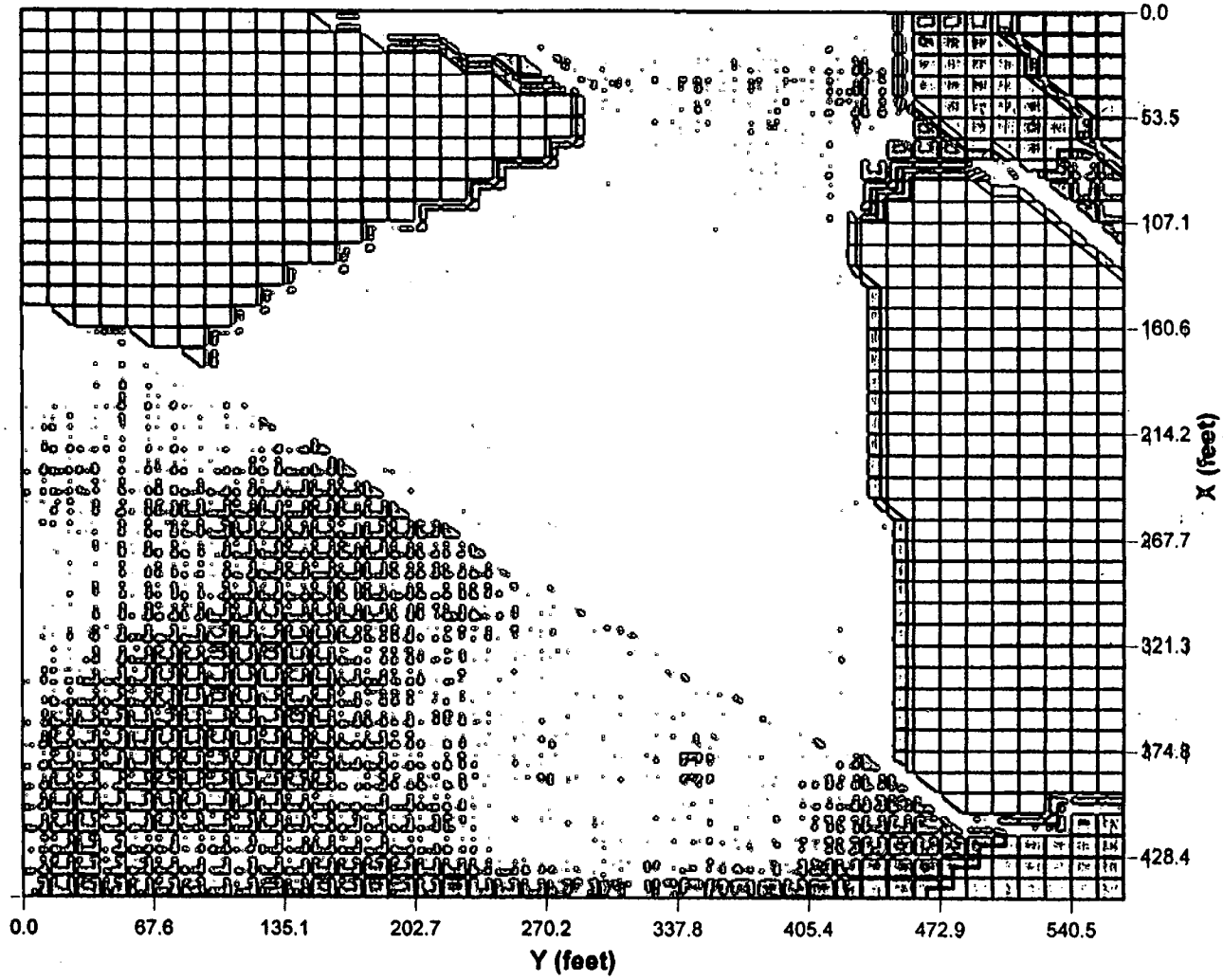

Sand

Silt

Clay

Gravel

Gravelly Sand

Gravelly Silt

Gravelly Clay

Gravel/Cobbles

Powder



# Neural Network-Fuzzy Logic Models and Genetic Algorithms

Can be used for Knowledge Acquisition

Can be use for Knowledge Discovery

Can be used as multi-objective optimization

Can handle conflicts between objectives

Can be used in imprecise, uncertain, and  
complex situations

Robust where there are multiple solutions

Efficient

Easy to use

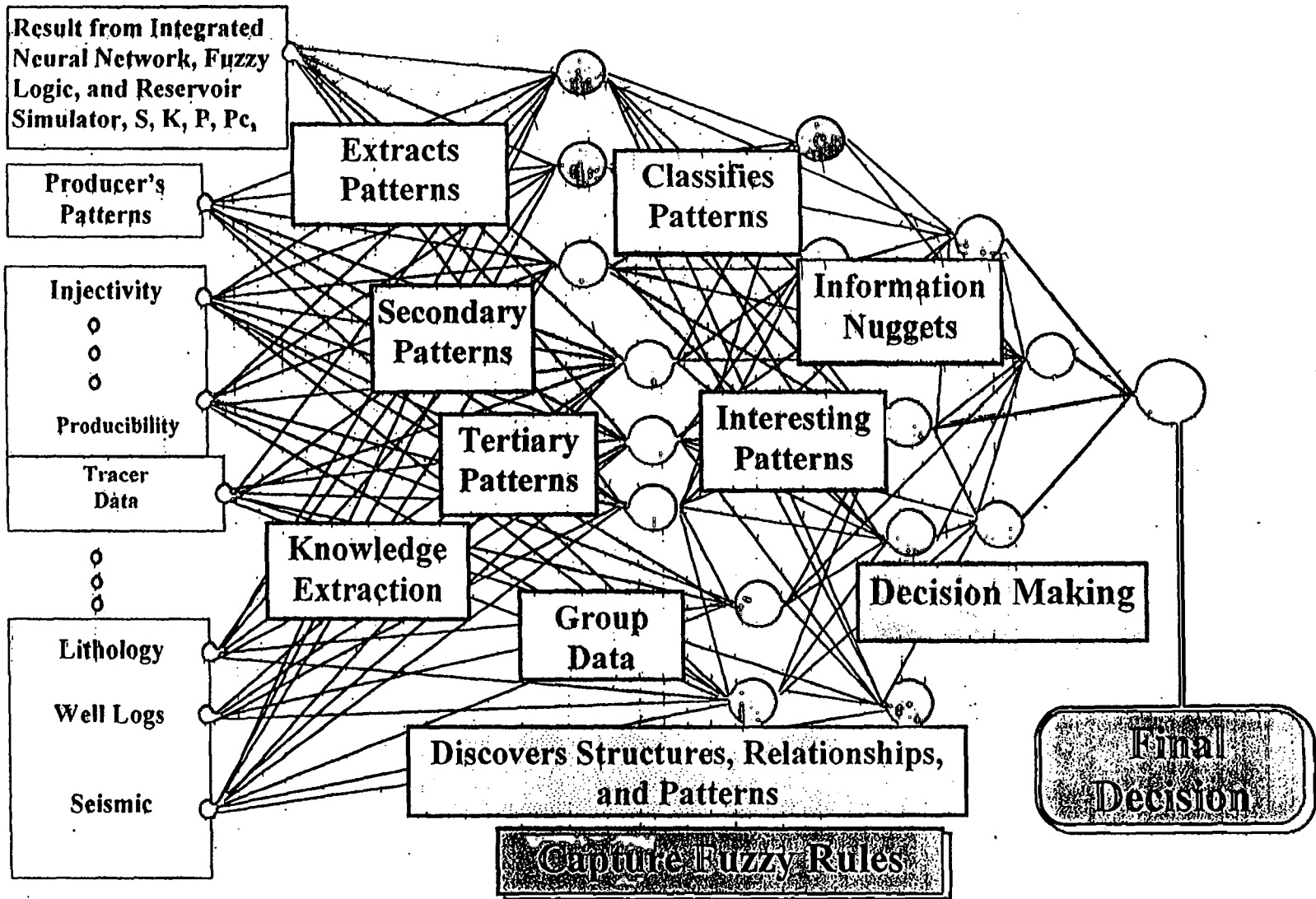

# **Geophysical Logs and Tests Required for Class I Deep Disposal Wells**

**Smith, Robert E.**  
Office of Ground Water and Drinking Water  
U.S. Environmental Protection Agency

July 8 - 9, 1997

## **JOINT RUSSIAN-AMERICAN HYDROGEOLOGY SEMINAR**

Russian - American Center for Contaminants Transport Studies  
Ernest Orlando Lawrence Berkeley National Laboratory  
Berkeley, California 94720



## Geophysical Logs and Tests Required for Class I Deep Disposal Wells

The following is a list of geophysical logs and tests that are required for Class 1 deep injection wells for hazardous and non-hazardous wastes:

### One-year Intervals

- Radioactive Tracer Log (RTS - I<sup>131</sup>)
  - \* Pathway of injected waste
  - \* No upward migration channels by casing/cement shoe
- Annulus Pressure Testing
  - \* Pressure up annulus (500-1000 psi) to verify no casing, tubing and packer leaks
  - \* May also run OA log to verify leaks (optional). Temp and noise logs may be used in combination especially where a RTS anomaly has been discovered
- Reservoir Testing
  - \* Pressure fall-off test to determine characteristics of injection zone, etc.
  - \* Well(s) must be shut-in for a period of time to make valid observation

### Five-year Intervals

- Temperature Log
  - \* Must run for entire length of casing
  - \* Check for inter-formational movement of fluids
- Casing Inspection Log (CIL)
  - \* To check for loss of casing material
  - \* Check for corrosion
- Cement Bond Log (CBL)
  - \* Check zone for isolation of waste
  - \* Well construction/loss of cement

## Well Plugging

- Run mechanical integrity test logs: RTS/Temp/Noise/OA
- Final well plugging run CIL and CBL before plugging well

## Other Logging Tools for Safety

- Open-hole logs
  - \* E-logs, SP log (dual induction), Neutron logs, micro E-logs, Fracture logs
- Repeat Formation Tester (RFT)
  - \* Open hole fluid sample
  - \* Sample injected water from other wells
  - \* Collar location (CBL, temp, casing, and CIL)
- Thermal Decay Tool (TDT)
  - \* To determine cavity top outside casing
- Sonar Caliper Log
  - \* To determine cavity size and direction

## **Discussion Highlights**

**Tsang, C.-F.**

E.O. Lawrence Berkeley National Laboratory

**Mironenko V. A.**

Russian Academy of Sciences

July 8 - 9, 1997

### **JOINT RUSSIAN-AMERICAN HYDROGEOLOGY SEMINAR**

Russian - American Center for Contaminants Transport Studies  
Ernest Orlando Lawrence Berkeley National Laboratory  
Berkeley, California 94720

## Discussion Highlights

*V. Mironenko and C.-F. Tsang*

The last session of the Seminar was devoted to impromptu contributions and informal unstructured discussions. Some of the contributions are included as separate chapters of these proceedings (Drozhko, E.G., et al. and Nikraves, M.). The informal discussions covered a variety of topics:

1. theory and modeling of groundwater flow and mass transport
2. site assessment
3. deep well injection
4. remediation of Lane Katachay site
5. general problems of remediations
6. conclusions

Some of these discussions are highlighted below.

Dr. J. Pashkovsky remarked that, according to theoretical investigations, dispersion coefficient in unsaturated zone is a complicated function of soil structure. So, it is necessary to estimate the real scale of heterogeneity of rocks for different kinds of real soils by field experiments. Such data can help us to calibrate the theoretical models of dispersion processes and make our forecasts more reliable.

Dr. A. Kuvaer discussed density convection impact on migration of hazardous wastes. In particular it causes fingering of pollution front on the micro- and macro levels. This effect greatly influences the hydrodynamic structure of flow. Improvement of predictions for groundwater contamination processes, development of monitoring and management of high density fluids in groundwater greatly depend on processes of density convection. Of major importance here is the evaluation of the "finger scale/groundwater flow scale" ratio.

Stochastic processes of contaminant transport by groundwater were analyzed by Dr. M. Shvidler, using some assumptions about the character of uncertainties of the geological media. Distributions of the concentration of contaminants were obtained on the basis of solutions of the Fokker-Planck's equations. These results could be of use as a benchmark for numerical modeling of the impact of uncertainties on contaminants transport processes.

From consideration of experience in deep-well injection of liquid industrial waste in Russia (non-radioactive and radioactive ones) and the USA (only non-radioactive waste), Dr. A. Rybakchenko inferred that this technique of waste management has prevented

pollution of the biosphere when it is carried out under conditions of control and regulation by authorized government institutions.

Taking into account the expansion in application of this technology in Russia and in the Asian countries, it is reasonable to develop an international collaboration in this field with the objective of exchanging experiences in deep-well injection, technology support in construction of new facilities and evaluation of the operating ones, as well as in performance of independent expert review on behalf of state and commercial institutions. The major stress is on drinking water resources safety.

Participants of the seminar reached an agreement for definite activities in this direction; in particular, to prepare a proposal for the organization of an International Council or Committee on deep injection of liquid waste, possibly within the International Association of Hydrogeologists or other international professional bodies.

On a separate line, discussion took place on the nature of forces that cause the motion of contaminated groundwater plume in the Karachai Lake area. Active discussion was participated by Dr. E. Drozhko, Dr. S. Posdniakov, Dr. A. Pek, and Dr. C-F Tsang. One conclusion was that the migration of contaminants from the Karachai Lake is strongly influenced not only by horizontal velocities, but also by density forces. Because of this, the topography of the aquifer bottom surface is a prime control on the direction of plume propagation. For the construction of reliable predictive models, more detailed information on the structure of permeability field is also necessary.

Dr. E. Drozhko discussed the current remediation activities at the Karachai Lake site and plans for the near future. These include covering up the lake bottom sediments by hollow concrete blocks; over the blocks will be placed a crushed rock layer, and over it, a clay layer. Trenches will be constructed in order to intercept the runoff and underground water from flowing into the covered lake. These measures will provide a restriction of radionuclides, keeping them from escaping from the lake into the underground water. Closure of the Novogornyy water intake also reduces usage of the contaminated underground water. This measure will be supported by the construction of a drainage trench on the left bank of the Myshelyak River. On the whole, the concept of contaminated underground water plume management at Mayak is to confine it within boundaries, with monitoring of the system through a network of observation wells.

Strategy of contaminant attenuation and groundwater remediation was discussed by V.A. Mironenko. The major drawbacks in many efforts in this field are: erroneously formulated measures of remediation; poor assessment of sites; unclear priorities for remediation; and improper distribution of funds between remediation itself and site characterization and experimental substantiation. There is much need to assess "the best" decision between the possible remediation alternatives, including natural remediation (attenuation) in particular. The processes of contaminant attenuation include:

1. dilution and displacement of contaminated water, its downward flow into the deep zones,
2. dispersion and diffusion,
3. capillary suction into the porous matrix,
4. volatilization,
5. physical and chemical interactions and transformations,
6. biodegradation.

The mentioned drawbacks in remediation could be essentially limited by the trial-and-operational, i.e. “self-teaching” approach, which permits a proper assessment and adjustment of final goals of remediation as well as its “best” choice. Such an approach does not demand remediation of the contaminated site completely, but guarantees the necessary groundwater quality at definite output points (e.g., water-intakes, springs and so on) under protection, i.e. in the real place and time of water usage. Within an assessment of “the best” remediation decision, three possible major alternatives can be successively considered:

1. natural attenuation (no action approach) with some provisions for monitoring regulations, and maybe, removal of the contamination source
2. the same, plus containment measures
3. active remediation

The high protective potential of the geological media forces us sometimes to use it for waste disposal in favor of the aboveground for biosphere safety. As an example, one can mention the Lake Karachai site or sites for underground storage of liquid radioactive wastes in Russia. In such cases we need a special strategy for gradual risk decreasing which is provided for by the trial-and-operational approach also.

In his concluding remarks, V. Mironenko talked about strong limitations on our forecasts reliability which stem from both theoretical pitfalls and (mostly) information barrier. As for the theory of mass-transport processes, the major problems here are connected with heterogeneity of various scales, which could essentially diverge for different processes, in particular for flow and chemical water-rock interactions. Another important theoretical problem is connected with a proper representation in our numerical models of concentration field over a wide range of values (7-8 orders of magnitude in the Lake Karachai case).

As for the information barrier, it is caused, first of all, by the lack and/or poor quality of data on flow properties (flow field structure). In particular, working with results of small-scale flow tests (e.g., slug tests), we are using different upscaling procedures to get properties not of the aquifers but of the near-borehole region, which is not the same. On the other hand, to obtain information by large-scale observation data, we are always under uncertainty due to the non-uniqueness of the appropriate inverse problem. So, various sophisticated methods in this field are to be considered with some reservation, and the

principle “the simpler, the better” (which practically means zonation according to geological features of the site) seems to be the most appropriate. In this connection, the speaker considers the recent extensive activity in stochastic modeling of mass-transport processes as going (in many cases) far away from the real hydrogeological needs.

It is the view of V. Mironenko that on the whole all the mentioned shortcomings of our predictions are quite typical for many contamination sites. For the gradual removal of contamination, the trial-and-operational strategy could be of some help. Otherwise, our models, which are always a work of fiction, are in danger of becoming a pure waste not contaminated by any connections with reality at all.

Finally, the speaker conveyed all Russian participants' satisfaction and gratitude for the excellent organizing of the workshop by the American hosts. This workshop has shown once more that our joint research within the Russian-American Center is most fruitful for both countries.

# Seminar Agenda

July 8 - 9, 1997

## **JOINT RUSSIAN-AMERICAN HYDROGEOLOGY SEMINAR**

Russian - American Center for Contaminants Transport Studies  
Ernest Orlando Lawrence Berkeley National Laboratory  
Berkeley, California 94720



**AGENDA**  
**JOINT RUSSIAN-AMERICAN HYDROGEOLOGY SEMINAR**

*Russian - American Center for Contaminants Transport Studies*  
*Ernest Orlando Lawrence Berkeley National Laboratory*  
*Berkeley, California 94720*

**July 8 Morning, Tuesday, Perseverance Hall at LBNL cafeteria:**

**Session Chair: Chin-Fu Tsang**

**Scientific Secretary: Sergey Pozdniakov**

---

8.45 - 9.00	<b>Benson S.</b> LBNL	<b>Welcome speech</b>
9.00 - 9.30	<b>Drozhko Eu. G.</b> PA Mayak	<b>Environmental problems at Mayak site</b>
9.30 - 10.00	<b>Vasil'kova N. A.</b> Gidrospetsgeologia	<b>Interpretation of field tests for evaluation of hydraulic properties of fractured rocks for Mayak site characterizations</b>
10.00 - 10.30	<b>Zubkov A. A.</b> Siberian Group of Chemical Enterprises	<b>Geotechnical monitoring of underground water deep injection wells and basins of liquid radioactive waste sites of Siberian Chemical Combine</b>
10.30 - 11.00	<b>Coffee break</b>	
11.30 - 12.00	<b>Rybalchenko A. I.</b> VNIIPIT, MINATOM	<b>Study of radionuclides transport in deep-well injection of liquid radioactive wastes in Russia</b>
11.30 - 12.00	<b>Pek A. A.</b> Russian Academy of Sciences	<b>Preliminary assessment of radionuclides migration from the HLW repository at the Mayak site</b>
12.00 - 12.30	<b>Malkovsky V. I.</b> Russian Academy of Sciences	<b>Migration of liquid radioactive plume in the sloping aquifer</b>
<hr/>		
12.30 - 1.30	<b>Lunch</b>	
<hr/>		
1.30 - 2.00	<b>Mironenko V. A.</b> Russian Academy of Sciences	<b>Efficient strategy of ground water quality control and remediation at old contaminated sites</b>

2.00 - 2.30	<b>Kuvaev A. A.</b> Moscow State University	<b>Salt-water convection in porous media on different scales</b>
2.30 - 3.00	<b>Pashkovsky I. S.</b> Geolink Co	<b>Ground water contamination caused by organic pollutants</b>
<hr/>		
3.00 - 3.30	<b>Coffee break</b>	
<hr/>		
3.30 - 4.30	<b>Barenblatt G. I.</b> Russian Academy of Sciences	<b>Non-equilibrium flows of fluids in natural rocks</b>
4.30 - 5.00	<b>Grant S. A.</b> CRREL	<b>Hydrogeological and geochemical aspects of proposed long-term storage of high level radioactive waste in permafrost rock</b>
5.00 - 5.30	<b>Narasimhan T. N.</b> UC Berkeley	<b>Hydraulic characterization: Evolution of ideas.</b>
7.00	<b>Tatarchuk Y. I.</b> Gidrospeitsgeologia	<b>Banquet speech</b>

**July 9, Wednesday, Perseverance Hall at LBNL cafeteria:**

**Session Chair: Angelos Findikakis**

**Scientific Secretary: Sergey Pozdniakov**

9.00 - 9.30	<b>Parker F. L</b> Vanderbilt University	<b>Potential remediation measures at Mayak site</b>
9.30 - 10.00	<b>Clark E. J.</b> E.I. du Pont de Nemours & Co	<b>Deep well injection - subsurface treatment</b>
10.00 - 10.30	<b>Kanivetsky R.</b> Minnesota Geological Survey	<b>Arsenic in Minnesota's ground-water: Regional trends and hydrogeochemical modeling</b>
10.30 - 11.00	<b>Coffee break</b>	
11.30 - 12.00	<b>Prilepin V. M.</b> Tetra Tech EM, Inc.	<b>Modeling fate and transport of petroleum constituents in vadose and saturated zone using SESOIL and AT123D</b>
11.30 - 12.00	<b>Taffet M. J.</b> LLNL	<b>Contaminant hydrogeology of radionuclides at LLNL site 300</b>
12.00 - 12.30	<b>Pedler W.H.</b> Colog, Inc.	<b>Hydrophysical logging: a review of case studies</b>
<hr/>		
12.30 - 1.30	<b>Lunch</b>	
<hr/>		
1.30 - 3.00	<b>Tsang C.F.</b> LBNL moderator	<b>Topical discussion: Site characterization, Monitoring, Modeling</b>
3.00 - 3.30	<b>Coffee break</b>	
3.30 - 5.00	<b>Tsang C.F.</b> LBNL moderator	<b>Topical discussion: Remediation approaches, Deep injection disposal, Underground repository</b>
5.00 - 5.15	<b>Mironenko V. A.</b> Russian Academy of Sciences	<b>Conclusion remarks</b>
5.15 - 5.30	<b>Tsang C.F.</b> LBNL	<b>Conclusion remarks</b>
<hr/>		
7.00	<b>No-host Dinner</b>	<b>Informal discussion</b>
<hr/>		

# LIST OF PARTICIPANTS

July 8 - 9, 1997

## **JOINT RUSSIAN-AMERICAN HYDROGEOLOGY SEMINAR**

Russian - American Center for Contaminants Transport Studies  
Ernest Orlando Lawrence Berkeley National Laboratory  
Berkeley, California 94720

# JOINT RUSSIAN- AMERICAN HYDROGEOLOGY SEMINAR

ATTENDEES & PARTICIPANTS

July 8-9, 1997

Prem Attanayake  
Bechtel National, Inc.  
Fifth Beale Street  
San Francisco, CA 94105  
Tel: 1-415-768-0454  
Fax: 1-415-768-4898

Ralph C. Cady  
Office of Nuclear Regulatory Res.  
U.S. Nuclear Regulatory Commission  
Mail Stop T9-F33  
Washington, D.C.  
Tel: 1-301-415-6249  
Fax: 1-301-415-5389  
Email: REC2@NRC.gov

Nadim Coptly  
Bechtel  
45 Fremont Street  
San Francisco, CA 94720  
Tel: 1-415-768-4431  
Fax: 1-415-768-4898  
Email: NKCopty@bechtel.com

Eugene G. Drozhko  
Mayak P.A.  
St. Gaydar 24 n. 281  
Ozersk, Chelaybinsk region  
456785, Russia  
Tel: 1-351-71-455-16  
Fax: 1-351-71-455-15

Boris Faybishenko  
Lawrence Berkeley National Lab  
1 Cyclotron Rd., MS 90/1116  
Berkeley, CA 94720  
Tel: 1-510-486-4852  
Fax: 1-510-486-5686  
Email: bfayb@lbl.gov

G.I. Barenblatt  
Dept. of Mathematics  
U.C. Berkeley/LBNL  
Berkeley, CA 94720  
Tel: 1-510-642-4162  
Fax: 1-510-642-8204

James E. Clark  
Senior Consulting Associates  
E.I. du Pont de Nemours & Co.  
MA83 - P.O. Box 3269  
Beaumont, TX 77704  
Tel: 1-409-727-9855  
Fax: 1-409-727-9970  
Email: clarkje@al.bmoa.umc.dupont.com

Vladimir Demchenko  
Scientific Consul  
Consulate General  
Russian Federation  
San Francisco, CA  
Tel: 1-415-202-9799  
Fax: 1-415-929-0306

Jacob D. Dustin  
Infrastructure & Technology Group  
Parsons Corporation  
260 S. Woodruff #313  
Idaho Falls, ID 83401  
Tel: 1-208-526-0398  
Fax: 1-208-526-8426

Angelos N. Findikakis  
Bechtel  
45 Fremont St.  
San Francisco, CA 94119  
Tel: 1-415-768-8550  
Fax: 1-415-768-8950  
Email: anfindik@bechtel.com

William Frangos  
Lawrence Berkeley National Lab  
1 Cyclotron Rd., MS 90-1116  
Berkeley, CA 94720  
Tel: 1-510-486-5399  
Fax: 1-510-486-3805  
Email: willy@csem.lbl.gov

Steven A. Grant  
Cold Regions Research & Engineering Lab.  
U.S. Army  
72 Lyme Road  
Hanover, NH 03755-1290  
Tel: 1-603-646-4446  
Fax: 1-603-646-4561  
Email: sgrant@crrel.usace.army.mil

Allen Htay  
Lawrence Berkeley National Lab  
1 Cyclotron Rd.  
Berkeley, CA 94720  
Tel: 1-510-486-7214  
Email: abhtay@lbl.gov

Roman Kanivetsay  
Minnesota Geological Survey  
2642 University Ave.  
St. Paul, MN 55108  
Tel: 1-612-627-4790  
Fax: 1-612-627-4778  
Email: kaniv001@maroon.tc.umn.edu

Andzej A. Kuvaev, Faculty  
Geology Hydrogeology Group  
Moscow State University  
Moscow Russia 119899  
Tel: 7-095-939-4936  
Fax: 7-095-939-4939  
Email: akuvaev@geol.msu.ru

Valery A. Mironenko  
St. Petersburg State University  
14 Linija, 29  
St. Petersburg, 199178 Russia  
Tel: 1-812-213-0795  
Fax: 1-812-114-4306  
Email: spmidoe@glas.apc.org

Iouri V. Glagolenko  
Mayak P.A.  
St. Gaidar 20 r. 53  
Ozersk Cheliabinsk Region  
Russia 456785, Russia  
Tel: 1-351-71-455-15  
Fax: 1-351-71-455-15

Shelia Aizik Guberman  
Inst. of Applied Mathematics, Moscow  
Paragraph Int. C.  
1688 Dell Ave.  
Campbell, CA 95008  
Tel: 1-408-364-7733  
Fax: 1-408-374-5466  
Email: guberman@paragraph.com

Elena A. Kalinina  
GRAM, Inc.  
8500 Menaul Blvd., Suite B-370  
Albuquerque, NM 87112  
Tel: 1-505-848-0751  
Fax: 1-505-848-0764  
Email: EAKALIN@NWER.Sandia.gov

Robert E. Smith  
U.S. Environmental Protection Agency  
401 M St., SW (4606)  
Washington, D.C. 20460  
Tel: 1-202-260-7275  
Fax: 1-202-260-0732  
Email: Kobelski.bruce@epamail.epa.gov

Viktor I. Malkovsky  
IGEM  
Russian Academy of Sciences  
Staromonetny per, 35  
Moscow 109017 Russia  
Tel: 7-095 230-8440  
Fax: 7-095 230-2179  
Email: malk@igem.msk.su

T.N. Narasimhan  
LBNL/UCB  
467 Evans Hall  
Univ. of California, Berkeley  
Berkeley, CA 94720  
Tel: 1-510-642-4561  
Fax: 1-510-642-4561  
Email: VIJAYA@csa.lbl.gov

Thomas J. Nicholson  
Office of Nuclear Regulatory Res.  
U.S. Nuclear Regulatory Commission  
Mail Stop T9-F33  
Washington, D.C.  
Tel: 1-301-415-6268  
Fax: 1-301-415-5389  
Email: TJN@NRC.gov

Igor S. Pachkovski  
Russian-Swedish Joint Venture  
Russia, Moscow, 107207  
Altayskaja 2-33  
Tel: 7-095-115 9992  
Fax: 7-095-115 9992  
Email: geolink@glas.apc.org

Alexander Arnoldovich Pek  
IGEM  
Russian Academy of Sciences  
ICEM, Staromonetny pr. 35  
Moscow, 109017 Russia  
Tel: 7-095-230-84-40  
Fax: 7-095-230-21-79  
Email: pek@igem.msk.su

Vladimir M. Prilepin  
Tetra Tech EM, Inc.  
135 Main Street, Suite 1800  
San Francisco, CA 94105  
Tel: 1-415-222-8249  
Fax: 1-415-543-5480  
Email: prilepv@ttem1.com

Mark J. Shvidler  
Lawrence Berkeley National Lab  
Berkeley, CA 94720  
Tel: 1-510-486-6472  
Email: shvidler@fract2.lbl.gov

Michael J. Taffet  
Lawrence Livermore National Lab  
Box 808, L-544  
Livermore, CA 94551  
Tel: 1-510-422-6114  
Fax: 1-510-423-5764  
Email: taffet1@llnl.gov

Masoud Nikravesh  
Lawrence Berkeley National Lab  
1 Cyclotron Rd., MS 90/1116  
Berkeley, CA 94720  
Tel: 1-510-486-7728  
Fax: 1-510-486-5686  
Email: mnikravesh@lbl.gov

Frank L. Parker  
Vanderbilt University  
P.O. Box 1596  
Station B  
Nashville, TN 37235  
Tel: 1-615-343-2371  
Fax: 1-615-322-3365  
Email: parkerfl@VUSE.Vanderbilt.edu

Sergey Pozdnianov  
Geology Dept.  
Moscow State University  
117855 Vorobiory Gony  
Moscow, Russia  
Email: spozdniakov@glasnot.ru

Andrei I. Rybalchenko  
VNIPIPT  
Kashizskoe shosse 33  
Moscow 115409 Russia  
Tel: 7-095-324-15-65  
Fax: 7-095-324-51-96

Ardyth M. Simmons  
Lawrence Berkeley National Lab  
1 Cyclotron Rd., MS 90/1116  
Berkeley, CA 94720  
Tel: 1-510-486-7106  
Fax: 1-510-486-6115  
Email: asimmons@lbl.gov

Yuri Tatarchuk  
PSA Hydrospeztzgeologiya  
Krasin st. 7-1-136  
Moscow 123056 Russia  
Tel: 7-095-196-02-62  
Fax: 7-095-196-32-16

Chin-Fu Tsang  
Lawrence Berkeley National Lab  
Mailstop 90/1116  
Berkeley, CA 94720  
Tel: 1-510-486-5782  
Fax: 1-510-486-5686  
Email: CFTsang@lbl.gov

Harold Wollenberg  
Lawrence Berkeley National Lab  
1 Cyclotron Rd., 90/1116  
Berkeley, CA 94720  
Tel: 1-510-486-5344

Andrei Zubkov  
Siberian Group of Chemical Enterprises  
Seversk, 636070 Russia

Nelly A. Vasil'kova  
PSA Hydrospeztzgeologiya  
Krasin st. 7-1-136  
Moscow 123056 Russia  
Tel: 7-095-251-4977  
Fax: 7-095-251-4977

Tianfu Xu  
Lawrence Berkeley National Lab  
1 Cyclotron Rd.  
Berkeley, CA 94720  
Tel: 1-510-486-7057  
Email: tianfu@csa.lbl.gov





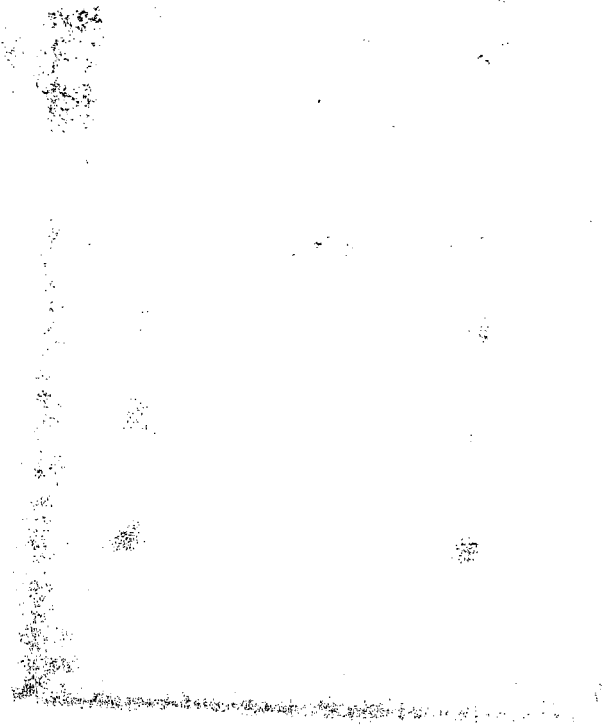

**ABT506**  
  
**LBL Libraries**