

Lawrence Berkeley National Laboratory

Recent Work

Title

SPECTROMETER STUDIES OF THE RADIATIONS OF NEUTRON DEFICIENT ISOTOPES OF CESIUM AND OF THE E3 ISOMERS, Xe127m AND Xe125m

Permalink

<https://escholarship.org/uc/item/3588j635>

Authors

Mathur, Hirdaya B.
Hyde, Earl K.

Publication Date

1954-01-25

UCRL 2469
UNCLASSIFIED

UNIVERSITY OF
CALIFORNIA

*Radiation
Laboratory*

TWO-WEEK LOAN COPY

*This is a Library Circulating Copy
which may be borrowed for two weeks.
For a personal retention copy, call
Tech. Info. Division, Ext. 5545*

BERKELEY, CALIFORNIA

DISCLAIMER

This document was prepared as an account of work sponsored by the United States Government. While this document is believed to contain correct information, neither the United States Government nor any agency thereof, nor the Regents of the University of California, nor any of their employees, makes any warranty, express or implied, or assumes any legal responsibility for the accuracy, completeness, or usefulness of any information, apparatus, product, or process disclosed, or represents that its use would not infringe privately owned rights. Reference herein to any specific commercial product, process, or service by its trade name, trademark, manufacturer, or otherwise, does not necessarily constitute or imply its endorsement, recommendation, or favoring by the United States Government or any agency thereof, or the Regents of the University of California. The views and opinions of authors expressed herein do not necessarily state or reflect those of the United States Government or any agency thereof or the Regents of the University of California.

UCRL-2469

Unclassified Chemistry Distribution

UNCLASSIFIED

UNIVERSITY OF CALIFORNIA

Radiation Laboratory

Contract No. W-7405-eng-48

SPECTROMETER STUDIES OF THE RADIATIONS OF
NEUTRON DEFICIENT ISOTOPES OF CESIUM AND
OF THE E3 ISOMERS, Xe^{127m} and Xe^{125m}

Hirdaya B. Mathur and Earl K. Hyde

January 25, 1954

Berkeley, California

SPECTROMETER STUDIES OF THE RADIATIONS OF
NEUTRON DEFICIENT ISOTOPEs OF CESIUM AND
OF THE E3 ISOMERS, Xe^{127m} and Xe^{125m}

Hirdaya B. Mathur* and Earl K. Hyde
Radiation Laboratory and Department of Chemistry
University of California, Berkeley, California

January 25, 1954

ABSTRACT

Cesium isotopes produced by $I^{127}(\alpha, xn)$ type reactions in the 60-inch and 184-inch cyclotrons were studied in Geiger counters, a mass spectrometer, beta ray spectrometers, a sodium iodide crystal scintillation spectrometer and a gamma-gamma coincidence spectrometer. The mass assignment of 30 minute Cs^{130} was verified. The 6.25 hour Cs^{127} was shown to decay predominantly by electron capture but also by the emission of positrons of 1.063 and 0.685 Mev energy. Prominent gamma rays of 61, 125 and 406 kev are observed. Cs^{127} exhibits branching decay to 75 second Xe^{127m} in about one disintegration in 10^4 . This isomer was isolated and studied in a scintillation spectrometer. E3 radiation of 175 kev connecting $h_{11/2}$ and $d_{5/2}$ levels is followed by 125 kev M1 radiation corresponding to a $d_{5/2} - d_{3/2}$ transition to the ground state. Forty-five minute Cs^{125} is shown to decay predominantly by electron capture and also by the emission of positrons of 2.05 Mev energy. Other lower energy positron groups are present. Prominent gamma rays of 66 and 112 kev are observed. In one disintegration in about 10^3 , Cs^{125} decays to a 55 second Xe^{125m} . This isomer emits gamma rays of 75 and 110 kev which are believed to be E3 $h_{11/2} - d_{5/2}$ and M1 $d_{5/2} - d_{3/2}$ transitions, respectively. An incomplete study of Cs^{123} shows it to be a 6 minute positron emitter.

*On leave of absence, Department of Chemistry, University of Delhi, Delhi, India.

SPECTROMETER STUDIES OF THE RADIATIONS OF
NEUTRON DEFICIENT ISOTOPES OF CESIUM AND
OF THE E3 ISOMERS, Xe^{127m} and Xe^{125m}

Hirdaya B. Mathur* and Earl K. Hyde
Radiation Laboratory and Department of Chemistry
University of California, Berkeley, California

January 25, 1954

I. INTRODUCTION

This report concerns a study of some neutron-deficient isotopes of cesium prepared by bombardment of iodine with high energy helium ions. The principal emphasis is on Cs^{127} and Cs^{125} although some preliminary data on Cs^{123} and a confirmation of the mass assignment of Cs^{130} are also reported. The work on Cs^{127} represents a considerable extension of the previous studies of Fink, Reynolds and Templeton,¹ while that on Cs^{125} and Cs^{123} represents completely new work. This report also describes a study of some short-lived isomers of Xe^{127} and Xe^{125} which appear in the decay of the cesium activities. The data on Xe^{127m} confirm and extend previous data on this isomer, while Xe^{125m} has not been reported before. Both isomers are of the E3 type.

The experimental results are presented and discussed first, following which a brief account is given of our chemical methods and of the various instruments used to study the radiations.

*On leave of absence, Department of Chemistry, University of Delhi, Delhi, India.

II. MASS ASSIGNMENT OF Cs^{130}

Following the preliminary studies of Risser and Smith² and of Fink, Reynolds and Templeton¹ on a 30 minute cesium activity produced in bombardments of iodine with low energy helium ions a careful study of the radiations emitted by this activity was carried out by Smith, Mitchell and Caird.³ There is little doubt that the activity is produced by the α, n reaction and hence that the mass is correctly assigned to mass number 130. Nevertheless it is probably worth recording the confirmation of this assignment by the use of a mass spectrograph.

Iodine in the form of calcium iodide was bombarded with 20 Mev helium ions in the 60-inch cyclotron. The cesium fraction was isolated in a carrier-free form within 1 hour of the end of the bombardment and run in the time-of-flight mass spectrometer described at the end of the paper. This work was done by M. C. Michel and D. H. Templeton. The 30 minute activity was collected in the 130 mass position.

III. THE RADIATIONS OF Cs^{127} AND THE ISOMER, Xe^{127m}

Fink, Reynolds and Templeton¹ reported Cs^{127} to be a positron activity with a half-life of 5.5 hours. The mass assignment was made by the identification of the 34 day Xe^{127} daughter. More recently Wapstra, Verster and Boelhouwer⁴ have studied the gamma rays of Cs^{127} by scintillation spectrometric methods and have reported gamma rays of 410 ± 20 and 125 ± 5 kev.

In our experiments we noted that the cesium fraction of a calcium iodide target bombarded with 60 Mev helium ions in the 184-inch cyclotron was a mixture of 30 minute Cs^{130} , 6.25 hour Cs^{127} and 31 hour Cs^{129} . Even

immediately after bombardment the major activity was Cs^{127} and if the isolation of the cesium were delayed a few hours past the end of the bombardment more than 90 percent of the GM activity was Cs^{127} .

The mass assignment was checked directly by a run in the time-of-flight mass spectrometer by Dr. Maynard C. Michel. Decay curves taken with a GM counter using mass separated Cs^{127} showed no deviation from a half-life of 6.25 ± 0.1 hours in more than 4 half-lives. This half-life is somewhat longer than that given by Fink et al.¹ Negligible 6.25 hour activity was collected at neighboring mass positions.

The positrons of Cs^{127} were studied in the beta ray spectrometers briefly described at the end of this report. The runs were not made with mass-separated activity since sources of sufficient intensity could not be prepared. However, the presence of a small amount of Cs^{129} caused no difficulty in the interpretation of data taken on unseparated cesium fractions isolated a few hours after bombardment. Our best runs were obtained on the lens spectrometer. Figure 1 shows the Fermi-Kurie plot of the positron spectrum. The most energetic component has an energy of 1.063 ± 0.010 Mev. The presence of numerous conversion electrons complicates the resolution of the second component and the value of 685 keV (378 keV lower in energy than the first component) is uncertain to perhaps 25 keV. This leaves unresolved the question whether the prominent 406 keV gamma ray observed in the scintillation spectrometer (see below) connects the Xe^{127} energy levels reached by these two positron groups.

Figures 2 and 3 show the gamma spectrum of mass-separated Cs^{127} as determined in the scintillation spectrometer. There are three prominent gamma rays of energies 61, 125 and 406 keV as well as a large 30 keV peak of

xenon x-radiation from the electron capture decay of Cs^{127} . The small amount of 510 kev annihilation radiation by comparison to this peak indicates a low β^+/EC ratio ($<1/15$). The relative amounts of the 61, 125 and 406 kev gamma rays after correction for counting efficiency are 1/2/~5.

Figures 4 and 5 show the conversion electron spectrum of Cs^{127} as studied on the magnetic double-focusing spectrometer and the lens spectrometer, respectively. In Table 1 the energies of the electrons, the conversion shell and the energy of the corresponding gamma rays are given. The K and L lines of the 61, 125 and 406 kev gamma rays are identified. Conversion electrons of 3 or more gamma rays of lower intensity in the region 125 to 400 kev are present but the assignment of K and L lines is uncertain. Nothing further was learned about this group since their intensity was so low that no further data was obtained in the scintillation spectrometer or the coincidence spectrometer.

Mr. Frank Stephens has assisted us in carrying out gamma-gamma coincidence studies on our Cs^{127} preparations with the following results: the 125 kev radiation is not in coincidence with the 61 kev radiation nor with the 406 kev radiation. It is in coincidence with 30 kev x-radiation and with 440 kev gamma radiation. The intensity of this latter was low enough to explain why it was not seen in the straight gamma spectrum runs. The 406 kev radiation was not in coincidence with 61 or 125 kev radiation, but was in coincidence with 30 kev x-radiation. In coincidence experiments in which annihilation radiation was selected by the gate crystal, coincidence peaks were observed at 125 and 406 kev.

Table 1
Conversion Electrons of Cs¹²⁷

Energy of Electrons in kev	Identification of Conversion Shell	Gamma Ray Energy in kev	K/L+M Ratio
23.6	Auger electrons	--	--
26.8	K conversion } L conversion }	61 kev	--
56.2			
90.0	K conversion } L conversion }	125 kev	7.9
119			
134	K conversion (?)	169 (?)	--
161	K conversion (?)	196 (?)	--
249	K conversion (?) } L conversion (?) }	285 (?)	--
280			
328	K conversion (?)	363 (?)	--
370	K conversion } L conversion }	406	6.3
400 L			

These findings in connection with the information derived from the isomer studies to be described next were employed in the construction of the proposed decay scheme shown in Figure 10. We have included a 280 kev gamma ray in Figure 10 to connect the $g_{7/2}$ and $d_{5/2}$ levels. We probably did see the conversion electrons of this transition (see Table 1) but the gamma intensity was too low for resolution from the scintillation spectrometer curves. In the coincidence studies the 125-280 kev coincidence to be expected from Figure 10 was looked for but unfortunately it was completely obscured by a large spurious 125-280 kev coincidence resulting from Compton scattering of the 406 kev gamma ray.

A number of preliminary experiments made it evident that the decay of Cs^{127} to the 75 second isomeric state of Xe^{127} was slight if it took place at all. This isomer had been reported by Creutz et al.⁵ who had bombarded iodide targets with 5-6 Mev protons to make Xe^{127} by the p,n reaction. In the volatile fraction removed from the target these workers had found two activities of 34 ± 2 days and 75 ± 1 seconds, respectively, and assigned both to Xe^{127} .

Studies of the conversion electrons emitted by the 75 second isomer using a permanent magnet spectrometer with photographic emulsion detection had shown 3 groups of 91.4, 140 and 170 kev, respectively. The first was interpreted as the K line of a 125 kev gamma ray and the last two as the K and L lines, respectively, of a 175 kev gamma ray. Xenon x-radiation resulting from the conversion of these gamma rays was also observed.

We were able to observe this isomer in the decay of Cs^{127} in the following manner. An active sample of carrier-free Cs^{127} was evaporated on a metal disc and placed in the depression of the slide of the apparatus diagrammed in Figure 6. The greased tight-fitting slide was pushed in until the cesium sample was located in the 1.5 inch diameter chamber 0.25 inch deep drilled in from the top of the block. This chamber was covered with a 0.1 mil foil of aluminum to prevent loss of xenon. After a growth period of 3 minutes the Cs^{127} sample was withdrawn. Recoil daughter atoms of Xe^{127} and Xe^{127m} ejected from the cesium source plate during the growth period remained in the closed chamber and their radiations were examined with the sodium iodide crystal mounted immediately above the chamber. The whole assembly was housed in a 2 inch thick lead castle. The gamma spectrum was determined with the 50 channel analyzer making runs at about 1 minute intervals for 10 or 15 minutes.

Figure 7 shows the spectrum of the recoil activity obtained immediately after the growth period. Two gamma rays of 125 and 175 kev energy are to be noted as well as xenon K x-rays. Since the decay of all three peaks followed a 75 second decay line (see Figure 8) we have little doubt that this is the same activity observed by Creutz et al.⁵ It was established more securely that this isomer was the product of the decay of Cs¹²⁷ by plotting the yield of the isomer in a 3 minute growth period as a function of the time at which the "milking" took place. The half-life of 6.1 hours so obtained as shown in Figure 9 confirms the genetic relationship.

A small amount of long-lived recoil activity remains after decay of the 75 second Xe^{127m}. If we assign all of this to 34 day Xe¹²⁷ we can estimate the branching of Cs¹²⁷ to 34 day Xe¹²⁷ and to 75 second Xe^{127m} to be in the ratio of $\sim 10^4/1$.

In their summary of nuclear isomers Goldhaber and Sunyar⁶ listed Xe^{127m} as an E3 isomer with the 175 kev gamma ray indicated as an $h_{11/2} \rightarrow d_{5/2}$ transition. They preferred to reinterpret tentatively the 91 kev electrons observed originally by Creutz et al.⁵ as L electrons of a 96 kev $d_{5/2} \rightarrow s_{1/2}$ E2 transition rather than as K electrons of a 125 kev transition. Their reason for this reassignment was the non-observation of L electrons of the 125 kev gamma ray which should have been prominent (K/L ratio $\sim 1-2$) for a 125 kev E2 transition. More recently Wapstra, Verster and Boelhouwer⁴ in discussing the 125 kev radiation prominent in the decay of Cs¹²⁷ stated that it was probably identical with the second transition in the decay of 75 second Xe^{127m} and that the 125 kev gamma ray represents an M1 transition going to a $d_{3/2}$ ground state in Xe¹²⁷. Our results appear to confirm this interpretation. The K/L+M ratio of 7.9 obtained by us for the 125 kev gamma ray in the decay of Cs¹²⁷ is of the correct magnitude for M1 and much too high for E2 radiation.

The $\text{Xe}^{127\text{m}}$ results have been incorporated in the decay scheme of Figure 10.

IV. THE RADIATIONS OF Cs^{125} AND THE ISOMER $\text{Xe}^{125\text{m}}$

In the bombardments of calcium iodide with helium ions a new positron activity of 45 minutes half-life appeared in the cesium fraction when the energy of the bombarding helium ions was raised to 100 Mev. One hour after the end of the bombardment this new isotope accounted for more than 80 percent of the GM activity in the cesium fraction, most of the rest being 6.25 hour Cs^{127} and a small amount of 31 hour Cs^{129} . When the xenon daughter activity was separated and deposited on metallic counting foils by the methods described below, decay curves taken on a GM counter showed a mixture of 18 hour Xe^{125} and 34 day Xe^{127} . This suggested that the 45 minute activity was Cs^{125} and the assignment was confirmed by mass separation. A GM decay curve of the mass 125 fraction isolated with the help of M. C. Michel and D. H. Templeton in the time-of-flight separator showed a straight line decay of 45 ± 1 minutes from an initial counting rate of 18,000 to less than 10 counts per minute. The counting efficiency of the 18 hour electron capture daughter Xe^{125} was very low in the GM tube but when the sample was placed in a "nucleometer" windowless methane flow proportional counter a decay line of 18 hours half-life was observed.

It was possible to determine the energy of the most energetic positron group of Cs^{125} by running a cesium sample in the double-focusing beta ray spectrometer starting about 1 hour after bombardment because this positron energy was greater than that of Cs^{127} . Figure 11 which shows a Fermi plot of the high energy region indicates that the energy of the Cs^{125} positrons is

2.05 ± 0.02 Mev. Because of the presence of Cs^{127} no attempt was made to resolve out lower energy components.

The gamma spectrum of mass-separated Cs^{125} (see Figures 12 and 13) shows gamma rays at 66 and 112 kev in addition to annihilation radiation and 30 kev xenon x-rays. No gamma rays of higher energy were observed. The large abundance of x-rays as compared to the gamma rays suggests that Cs^{125} decays prominently by electron capture but the EC/β^+ branching ratio was not determined. As in the case of Cs^{127} , gamma-gamma coincidence studies were carried out on Cs^{125} . It was observed that the 66 and 112 kev gamma rays are not in coincidence but that each one is in coincidence with K x-radiation and also with annihilation radiation.

The conversion electron spectrum was not studied in detail but the energy of the 112 kev gamma ray was checked by measurement of the K and L conversion lines. The K/L ratio was determined as 3.6. This may be somewhat in error since the time spent in obtaining the data made necessary rather large half-life corrections. It is believed that the 112 kev transition is the $d_{5/2} \rightarrow d_{3/2}$ transition in Xe^{125} analogous to the 125 kev transition in Xe^{127} . From Goldhaber and Sunyar's⁶ empirical curves one would expect a K/L ratio of 7-8 for an M1 transition of this energy.

At the suggestion of Dr. Ingmar Bergström we made a search for an isomer of Xe^{125} since his study of the systematics of the odd mass xenon isotopes⁷ as well as those of Goldhaber and Hill⁸ indicated the probability of a short-lived E3 isomer in Xe^{125} very similar to that in Xe^{127} . By performing experiments analogous to those described above in the Xe^{127m} case we have been successful in the search for this isomer but because the interference from 18 hour Xe^{125} was much greater than that from 34 day Xe^{127} the results are not quite as clean-cut.

Carrier-free cesium samples isolated within an hour of the end of bombardment from calcium iodide targets bombarded with 100 Mev protons were inserted in the depression of the slide of Figure 6 and pushed into the inner recoil collection chamber for one minute growth periods. Immediately after the cesium source was removed the gamma spectrum of the xenon daughter recoil activity was studied with the sodium iodide 50 channel analyzer. The registers were photographed with a Leica camera at 12 second intervals over a period of several minutes without disturbing the count switch. By subtraction of the dial readings of one negative from that of the next the spectrum during any particular 12 second period could be reconstructed. The upper curve of Figure 14 shows the spectrum integrated over the first one minute while the lower curve shows the spectrum of the second minute's run. It is seen that gamma rays of 75, 110, 187 and 245 kev as well as 30 kev x-radiation are present.

As shown in Figure 15 the areas under the x-ray peak, the 75 kev peak and the 110 kev peak decay initially with a half-life of 50-60 seconds and this decay in all likelihood is correctly assigned to $\text{Xe}^{125\text{m}}$. (The longer-lived component in the curves of Figure 15 is based on points not shown.) Part of the radiation at these energies and most or all of it at 187 and 245 kev is due to 18 hour Xe^{125} as will be discussed a little further on.

We are inclined to the view that the 75 kev peak in Figure 14 represents the E3 transition $h_{11/2} \rightarrow d_{5/2}$ and that the 110 kev peak represents the M1 $d_{5/2} \rightarrow d_{3/2}$ transition. The relative areas of the two peaks indicating higher conversion of the 75 kev gamma support this view. Also, if the 110 kev peak here can be identified with the 112 kev gamma seen prominently in Cs^{125} samples the high K/L ratio would be inconsistent for an E3 or E2 transition.

However, the assignments cannot be regarded as proved. One disturbing factor is the fact that the half-life of this isomer compared to $\text{Xe}^{127\text{m}}$ is shorter even though the energy of the transition is somewhat less.

One difficulty in the further study of the isomer is the low branching ratio for its production in the decay of Cs^{125} . This branching ratio was estimated by comparing the amount of 187 keV gamma radiation of Xe^{125} to the amount of 110 keV gamma radiation of $\text{Xe}^{125\text{m}}$ with suitable corrections for half-life and for the length of the growth period. Making the assumption of one 187 keV gamma ray per decay of Xe^{125} the branching decay of Cs^{125} to $\text{Xe}^{125\text{m}}$ is 10^{-3} .

A good part of the information on the decay of Cs^{125} and $\text{Xe}^{125\text{m}}$ is summarized in the proposed decay scheme of Figure 16. It can be observed that the decay schemes of Cs^{125} and Cs^{127} are very similar.

The longer-lived Xe^{125} formed in the decay of Cs^{125} is identical with the 18 hour activity mass-separated and characterized by Bergström.^{7,9} We repeated Bergström's scintillation spectrometer studies (but not his conversion electron studies) using Xe^{125} samples isolated by the glow discharge method from decayed Cs^{125} samples.

Figure 17 shows the gamma spectrum determined in the scintillation spectrometer. Definite photopeaks were observed at 56, 187 and 243 keV in agreement with Bergström. The small peak at 110 is probably Compton radiation from the 187 keV gamma ray. No annihilation radiation was observed. In the coincidence spectrometer it was established that the 56 and 187 keV gamma rays are in coincidence as was suggested by Bergström by the fact that the energies sum to 243 keV. In agreement with this the 243 keV gamma ray was not in coincidence with the 56 or 187 keV gamma rays. The 56 keV gamma ray must lie higher than the 187 keV gamma ray since the ratio of coincidence

pulses to gate pulses increased greatly when the gamma ray selected by the gate was changed from 187 to 56. The 96 and 106 kev gamma rays whose conversion electrons were observed by Bergström were too low in intensity to observe in our coincidence studies. We can set an upper limit of 2 percent for these gamma rays compared to the 187 and 243 kev gamma rays when the latter are applied to the gating circuit.

V. BRIEF REPORT ON Cs¹²³

In calcium iodide targets bombarded with helium ions of 130 Mev a new cesium activity of 6 minutes half-life was produced along with 45 minute Cs¹²⁵ and 6.25 hour Cs¹²⁷. When the xenon daughter activity grown in during a 5 minute period was isolated and deposited on thin metallic counting foils by the glow discharge method described below and followed for decay in a GM counter a mixture of 1.8 hour Xe¹²³, 13 hour I¹²³ and 18 hour Xe¹²⁵ was observed. When this procedure was repeated after complete decay of the 6 minute cesium parent no 1.8 hour Xe¹²³ was isolated. This identifies the 6 minute cesium activity as Cs¹²³. Annihilation radiation of 6 minute half-life was prominent in scintillation spectrometer curves taken on the cesium fraction shortly after the bombardment indicating that Cs¹²³ decays by positron emission. No detailed study of Cs¹²³ was carried out.

VI. EXPERIMENTAL PART

1. Cyclotron targets.--During the course of this work cesium isotopes were produced by $I^{127}(\alpha, xn)Cs^{<131}$ reactions by bombarding I¹²⁷ (100 percent abundance) in the form of calcium iodide with helium ions. The calcium

iodide was wrapped in 1 mil thick aluminum or 1/2 mil platinum foil. In the 184-inch cyclotron bombardments helium ions ranging from 60 to 150 Mev were obtained by inserting the target to the correct radial setting. For the studies of Cs^{130} calcium iodide was bombarded with 20 Mev helium ions in the 60-inch cyclotron.

2. Chemical isolation of cesium.--The calcium iodide was dissolved in water and the solution was saturated with gaseous hydrogen chloride while being cooled with ice water. Several drops of 0.4 molar silicotungstic acid was added to precipitate free silicotungstic acid. This precipitate was centrifuged from the solution carrying cesium activity. The silicotungstic acid was dissolved in 2 drops of water and reprecipitated by the addition of cold saturated hydrochloric acid for more purification. Finally the silicotungstic acid dissolved in 0.5 ml water was passed through a 1 cm x 4 mm column of Dowex-50 cation exchange resin. The cesium adsorbed on the resin while the silicotungstic acid passed through. The resin column was washed free of silicotungstic acid with distilled water following which the cesium activity was quickly desorbed from the column with a few drops of 6 M hydrochloric acid. The cesium so obtained was carrier free. This procedure is described more fully elsewhere.¹⁰

3. Preparation of xenon counting foils.--Samples of daughter xenon activity produced in the decay of the cesium isotopes were deposited on thin metallic foils by the method developed and used extensively by F. F. Momyer and E. K. Hyde for the study of isotopes of emanation.¹¹ This method makes use of a glow discharge tube of the type shown in Figure 18. Xenon was swept

out of the cesium solution in a closed glass vacuum system and after crude fractionation from less volatile impurities was transferred by condensation at the temperature of liquid air into the glow discharge tube together with sufficient inert gas to raise the total pressure in the tube to the region of 100-1000 microns when the stopcock leading to the tube was closed and the gas was allowed to warm up. When a DC potential of 400-600 voltage was placed across the electrodes with a 50,000 ohm resistor in the circuit a glow discharge was produced. The discharge served to ionize the xenon atoms and the resulting ions were accelerated into the cathode with sufficient velocity that they remained affixed to the plate when the discharge was terminated. In a run of 5-10 minutes about 5 percent of the xenon activity could be deposited. The xenon was collected either on 1 mil platinum discs or on 0.1 mil aluminum foil. At room temperature the xenon activity remained affixed to the foils indefinitely. A more complete description of this method will be given in a forthcoming paper describing our studies on Xe^{121} , Xe^{122} and Xe^{123} .

4. Time-of-flight mass spectrometer.--The mass assignment and isotopic separation reported in this report were done on a time-of-flight isotope separator in use in this laboratory. An unpublished account of this instrument has been given by W. E. Glenn¹² and a full description will be published by M. C. Michel and D. H. Templeton¹³ shortly. The instrument is a medium-resolution, high-transmission time-of-flight mass separator which is used to collect samples of radioactive isotopes in the mass region 65 to 270. The overlapping of one mass on adjacent masses is less than 1 percent of peak intensity.

-17-

In the case of cesium isotopes, the ion source was a tungsten ribbon surface on which carrier-free Cs_2SO_4 was evaporated. The tungsten ribbon was heated electrically in the source region to produce thermal ions with a low spread in energy.

For the purpose of collection of active isotopes, the ions are discharged on a platinum counting plate introduced in the collection end at ground potential. The majority of ions formed are of the type M^+ which are nonvolatile when discharged and remain as a thin uniform covering on the metal surface exposed to the beam. The metal plate can thus be used directly for counting measurements.

It was thus possible to get separated single isotopes of purity greater than 99 percent with a yield from 5-10 percent of the activity placed on the source filament as compared to 1 percent yield obtained by the conventional magnetic mass spectrometer.

It is possible to work rapidly in order to assign short half-lives.

5. Beta ray spectrometers.--Two precision beta ray spectrometers were used. The first was a 25 cm radius of curvature spectrometer of the double-focusing type proposed by Svartholm and Siegbahn¹⁴ and by Shull and Dennison.¹⁵ A side window GM tube was used as a detector. This tube had a 0.005 inch platinum central wire; a thin window of vinyl plastic supported on a grid of 0.001 inch tungsten wires and was filled to a regulated pressure of 8.8 cm with a gas mixture 90 percent argon and 10 percent ethylene. A more complete description of the instrument is given in an unpublished report by O'Kelley.¹⁶

The calibration for negative electrons was checked with the K line of the 662 keV gamma ray of Cs^{137} , and the K line of the 80.1 keV gamma ray of I^{131} . The transmission of the spectrometer under the conditions used was ~ 0.3 percent. For the study of the positrons the calibration was checked with the 1.97 MeV positron of Cs^{130} . We are indebted to Mr. Thomas O. Passell for major assistance in the use of this instrument.

Cesium samples for the spectrometer were prepared by evaporating the carrier free activity dissolved in hydrochloric acid on gold leaf of $87 \mu\text{gm}/\text{cm}^2$ thickness. The gold leaf was supported on a brass ring.

For the study of the positrons and electrons of Cs^{127} the results on the double-focusing spectrometer were supplemented by studies carried out on a magnetic lens type spectrometer with somewhat lower resolution but considerably higher transmission (about 1 percent). This instrument was made available to us through the kindness of the chemistry division of the California Research and Development Corporation and we are particularly indebted to Mr. James Olson and Dr. G. D. O'Kelley for assistance in its use. The cesium samples used in this instrument were mounted on a single layer of tygon film ($\sim 20 \mu\text{gm}/\text{cm}^2$) supported by a plastic ring.

6. Scintillation spectrometer.—The gamma ray scintillation spectrometer used in this work was assembled by A. Ghiorso and A. E. Larsh of this laboratory. The gamma detection initially occurred in a 1.5 inch diameter by 1 inch thick crystal of sodium iodide (thallium activated) procured from Harshaw Chemical Company. The photomultiplier coupled to the crystal was a Dumont 6292 tube. The mounting of the crystal followed methods described by Borkowski.¹⁷ On the side of the crystal facing the photomultiplier tube was

affixed a quartz disc; a layer of oil between quartz and outside surface of the tube provided optical coupling. The other surfaces of the tube were packed into a reflecting layer of magnesium oxide. The whole assembly was mounted in an aluminum lined lead shield on top of a standard GM counter 5 position shelf assembly. Incident gamma rays penetrated a thin foil of beryllium ($\sim 150 \text{ mg/cm}^2$) and a thin layer of magnesium oxide (about 1/16 inch) before entering the crystal.

The output pulse from the photomultiplier was amplified in a preamplifier, then in a linear amplifier. The final pulse is introduced to a 50 channel differential pulse height analyzer. The analyzer based on a novel use of 6BN6 as one arm of a gated univibrator, is a new design of Ghiorso and Larsh. After proper alignment the channel width stability (operating at a 5 volt channel width) was better than 1 percent and remained so for a period of weeks. Gain and bias controls permitted the inspection of any predetermined energy intervals with the full 50 channels. In order to calibrate the apparatus at any particular gain and bias settings, use was made of the known energies in the gamma spectrum of various standards such as annihilation radiation from Na^{22} , 662 kev radiation from Cs^{137} , 60 kev radiation from Am^{241} , 184 kev radiation from U^{235} , etc. Further details of this equipment will be obtainable in a forthcoming publication of Ghiorso and Larsh.¹⁸

The gamma-gamma coincidence spectrometer incorporated the above equipment in combination with a second single-channel pulse height analyzer. The sample was mounted between two sodium iodide photomultiplier tube detectors. Pulses resulting from events in the gate crystal were fed to the single-channel analyzer and those corresponding to a selected gamma energy interval were used to gate a coincidence circuit. Pulses arriving from the second

crystal in coincidence with these were fed to the 50 channel analyzer. Hence the gamma spectrum in coincidence with a particular gamma ray could be determined quickly.

ACKNOWLEDGMENTS

The authors wish to express their thanks to James T. Vale, Lloyd Houser and members of the 184-inch cyclotron crew for the numerous 184-inch cyclotron bombardments. Similarly, acknowledgment is made to G. B. Rossi, W. B. Jones and members of the 60-inch cyclotron crew. We acknowledge the indispensable assistance of Drs. M. C. Michel and D. H. Templeton in the mass separations, and of Mr. T. O. Passell for the beta ray spectroscopy studies, and Mr. F. S. Stephens for the coincidence studies. The work with the lens spectrometer was carried out with the assistance of Mr. J. L. Olson and Dr. G. D. O'Kelley of the California Research and Development Corporation, Livermore, California.

This work was performed under the auspices of the U. S. Atomic Energy Commission.

REFERENCES

1. R. W. Fink, F. L. Reynolds and D. H. Templeton, Phys. Rev. 77, 614 (1950).
2. J. R. Risser and R. N. Smith, private communication from K. Lark-Horowitz (1948) as reported by Hollander, Perlman and Seaborg, Revs. Modern Phys. 25, 469 (1953).
3. A. B. Smith, A. C. G. Mitchell and R. S. Caird, Phys. Rev. 87, 454 (1952).
4. A. H. Wapstra, N. F. Verster and M. Boelhouwer, Physica XIX, 138 (1953).
5. E. C. Creutz, L. A. Delasasso, R. B. Sutton, M. G. White and W. H. Barkas, Phys. Rev. 58, 481 (1940).
6. M. Goldhaber and A. W. Sunyar, Phys. Rev. 83, 906 (1951).
7. I. Bergström, Arkiv för Fysik 5, 191 (1952).
8. M. Goldhaber and R. D. Hill, Revs. Modern Phys. 24, 179 (1952).
9. I. Bergström, Phys. Rev. 82, 111 (1951).
10. E. K. Hyde, J. Am. Chem. Soc. 74, 4181 (1952).
11. F. F. Momyer, University of California Radiation Laboratory Unpublished Report UCRL-2060 (1953).
12. W. E. Glenn, University of California Radiation Laboratory Unpublished Report UCRL-1628 (January 1952).
13. M. C. Michel and D. H. Templeton, to be published.
14. N. Svartholm and K. Siegbahn, Arkiv. Mat. Astron. Fysik 33A No. 21 (1946); see also Hedgran, Siegbahn and Svartholm, Proc. Phys. Soc. (London) 63A, 960 (1950).
15. F. Shull and D. Dennison, Phys. Rev. 71, 681 (1947); 72, 256 (1947).
16. G. D. O'Kelley, University of California Radiation Laboratory Unpublished Report UCRL-1243 (March 1951).

17. C. J. Borkowski, Oak Ridge National Laboratory Unpublished Report ORNL-1336 (September 1952).
18. A. Ghiorso and A. E. Larsh, Jr., to be published.

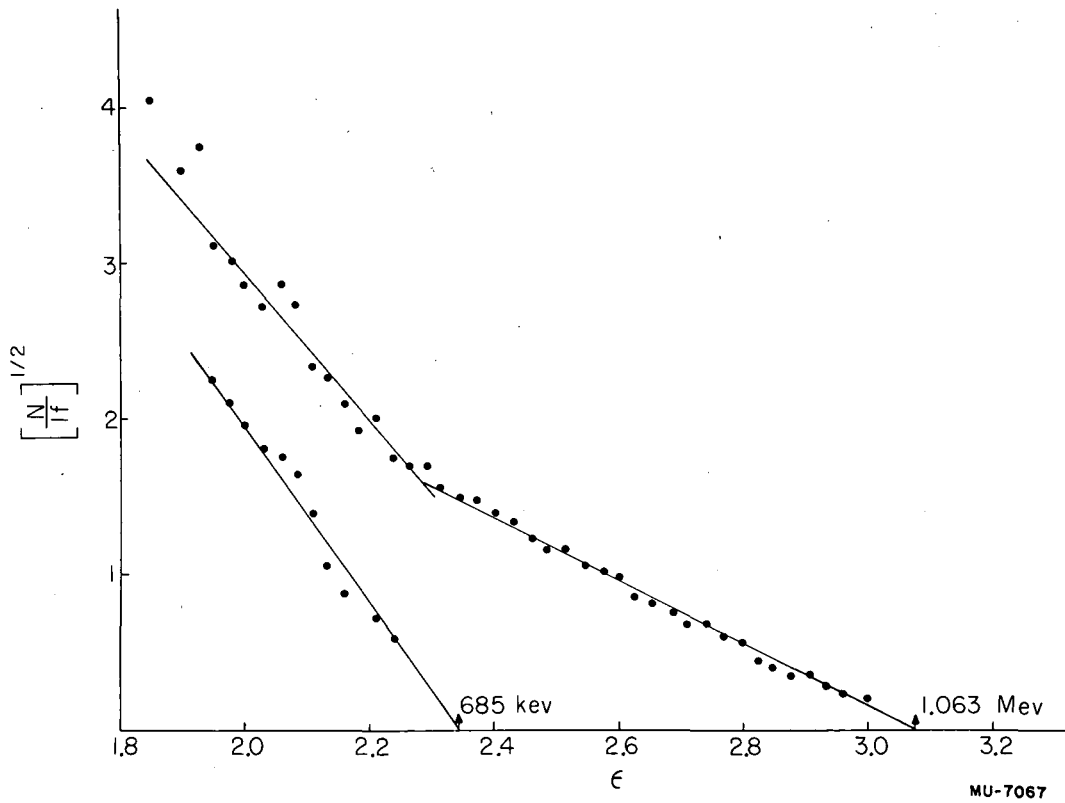

MU-7067

Fig. 1. Fermi-Kurie plot of high energy portion of Cs^{127} positron spectrum. Resolution of a second component after correction for conversion electrons is shown.

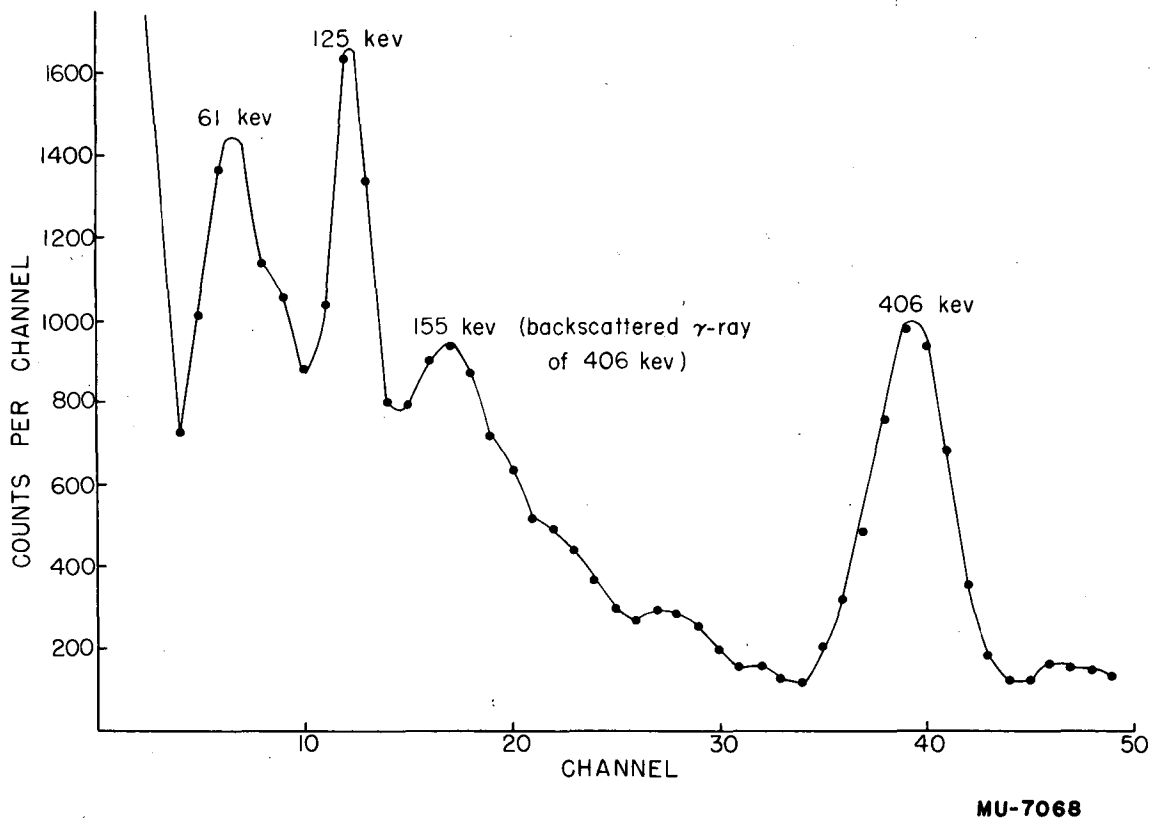
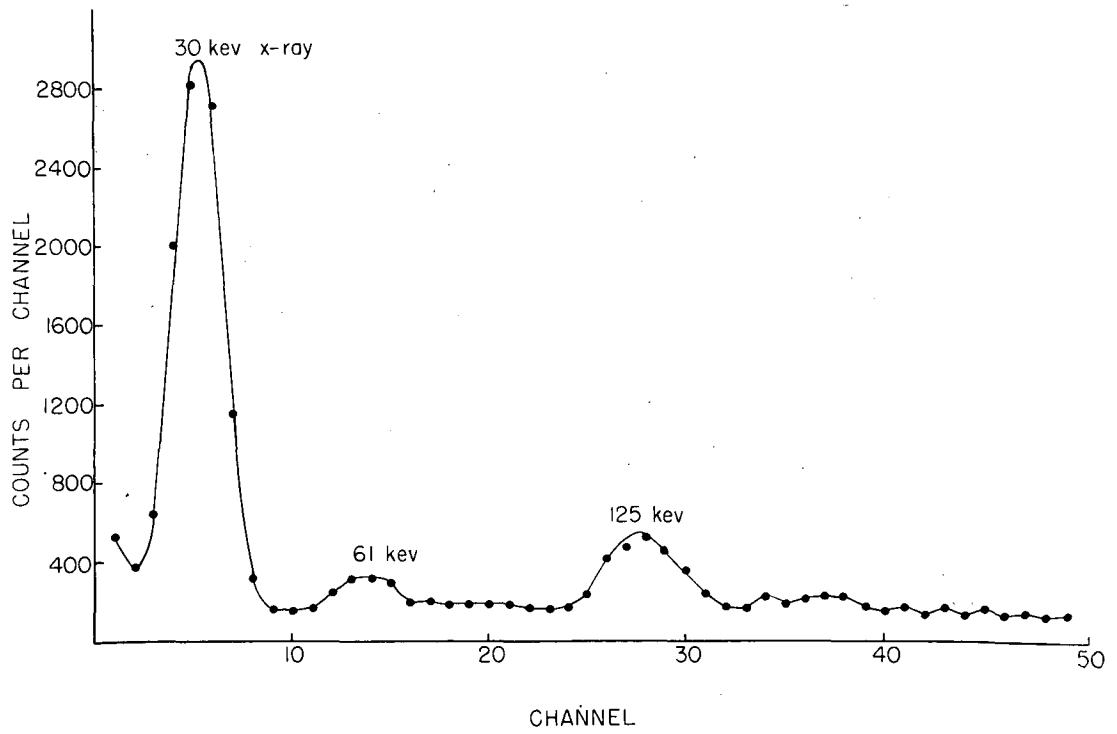

Fig. 2. Gamma spectrum of mass-separated Cs^{127} determined in scintillation spectrometer.

MU-7068



MU-7069

Fig. 3. Gamma spectrum of mass-separated Cs¹²⁷ in 0-200 keV region showing prominent x-ray peak.

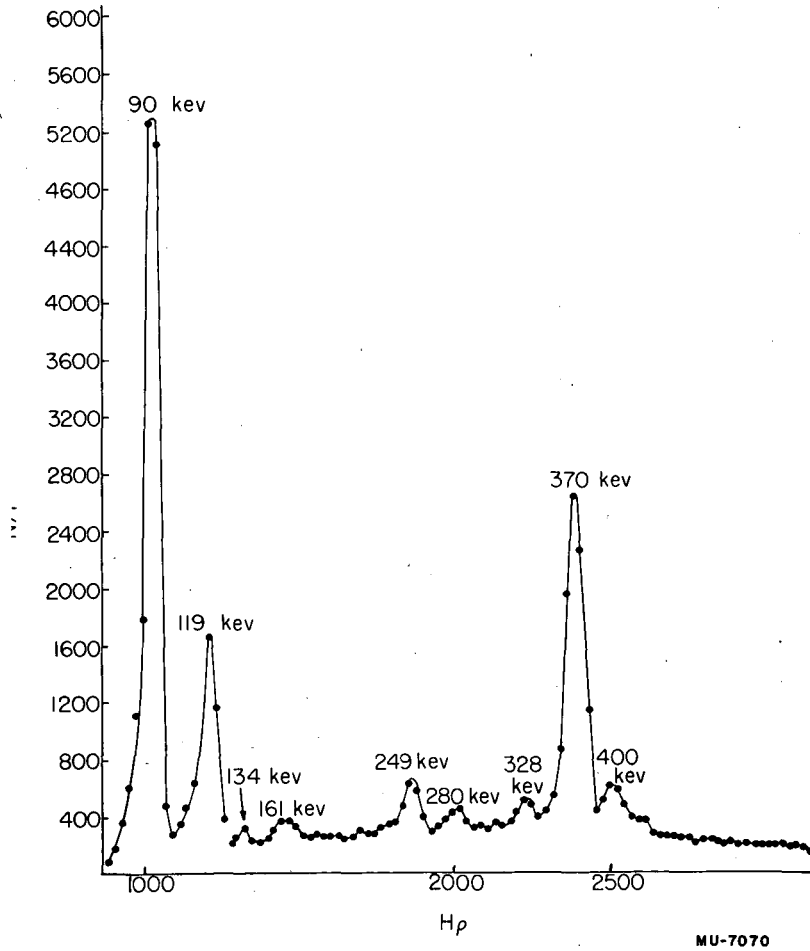
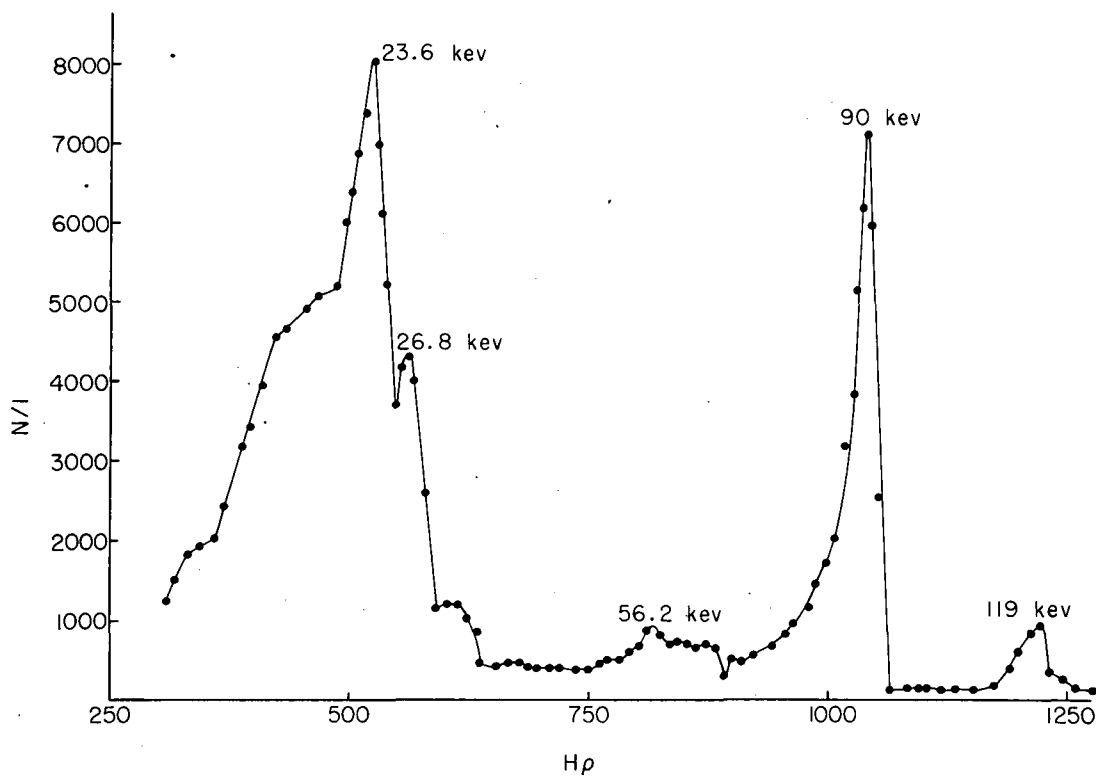
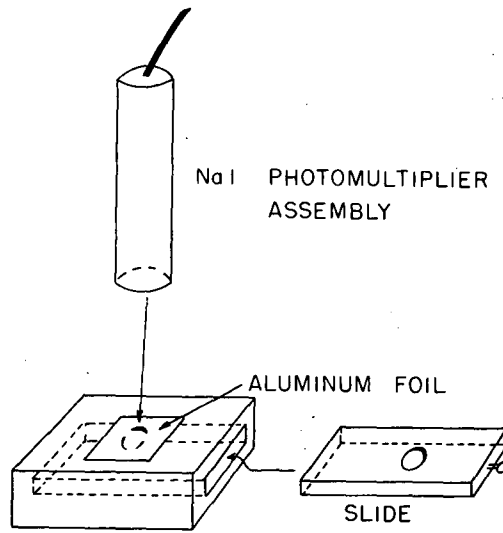

Fig. 4. Conversion electron spectrum of Cs¹²⁷ in 80-450 keV region determined in lens spectrometer.



MU-7071

Fig. 5. Conversion electron spectrum of Cs¹²⁷ in 0-120 keV region determined in double-focusing spectrometer.



MU-7072

Fig. 6. Apparatus for the collection and study of the gamma spectrum of short-lived xenon daughter activity from Cs^{127} or Cs^{125} samples.

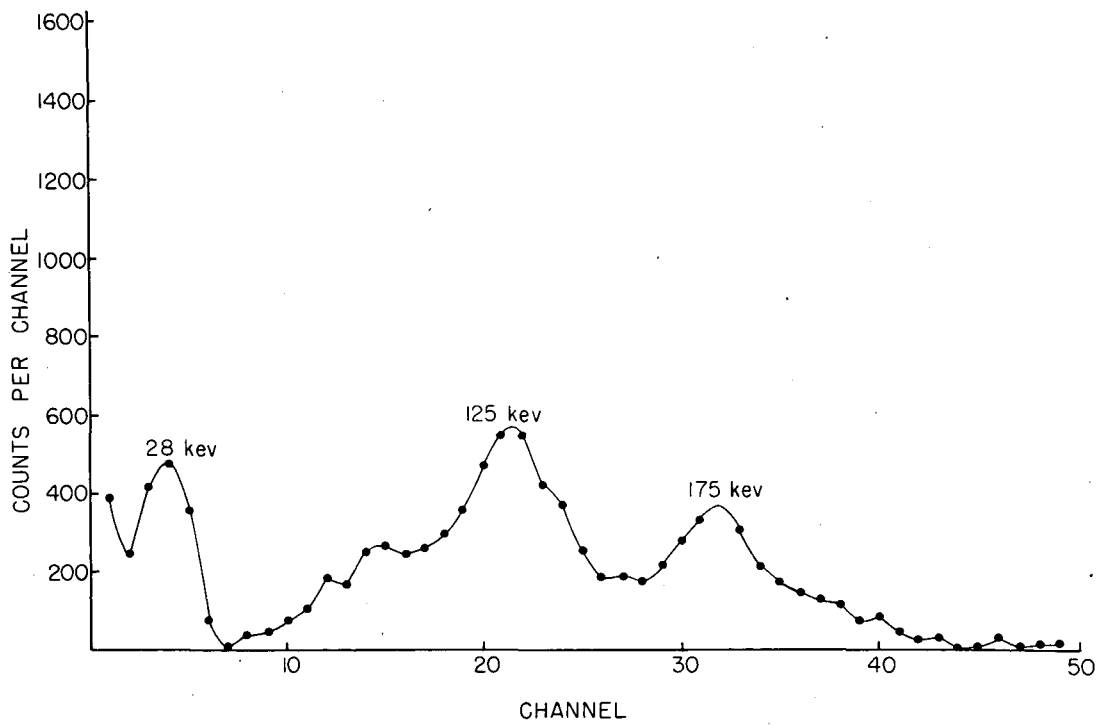

MU-7073

Fig. 7. Gamma spectrum of Xe^{127m} .

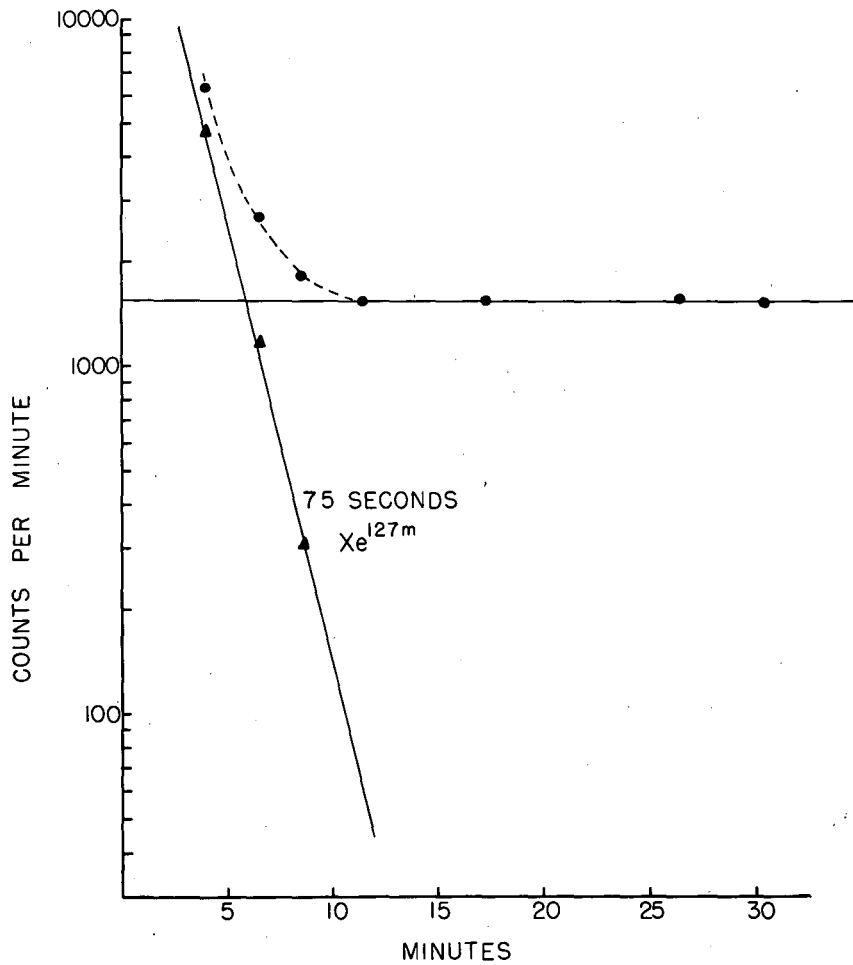

MU-7074

Fig. 8. Decay of activity in gamma peaks of Fig. 7 showing resolution of 75 second activity.

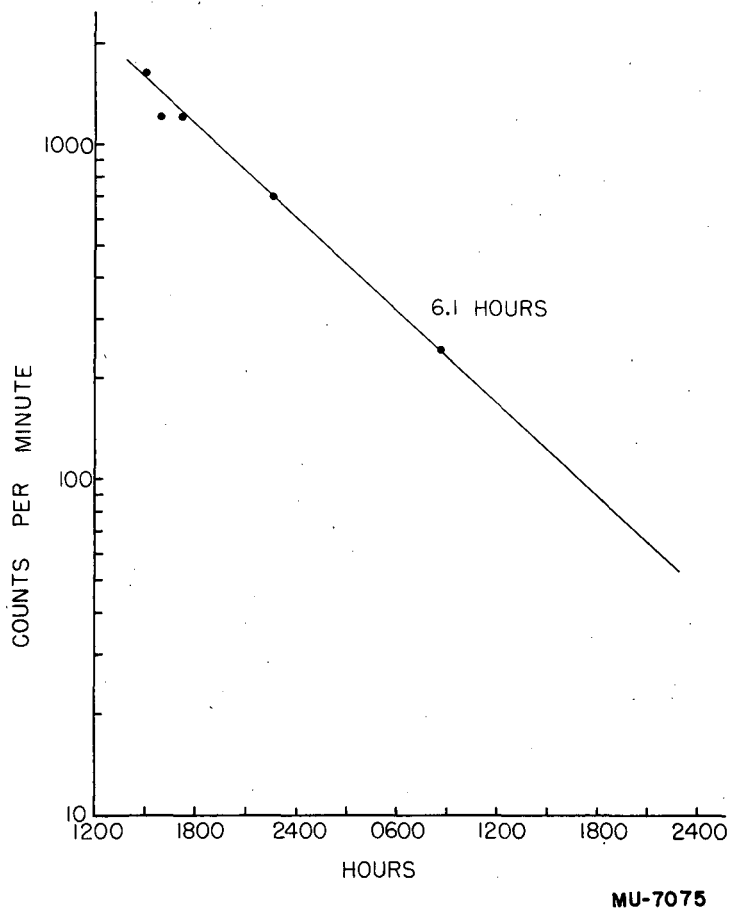
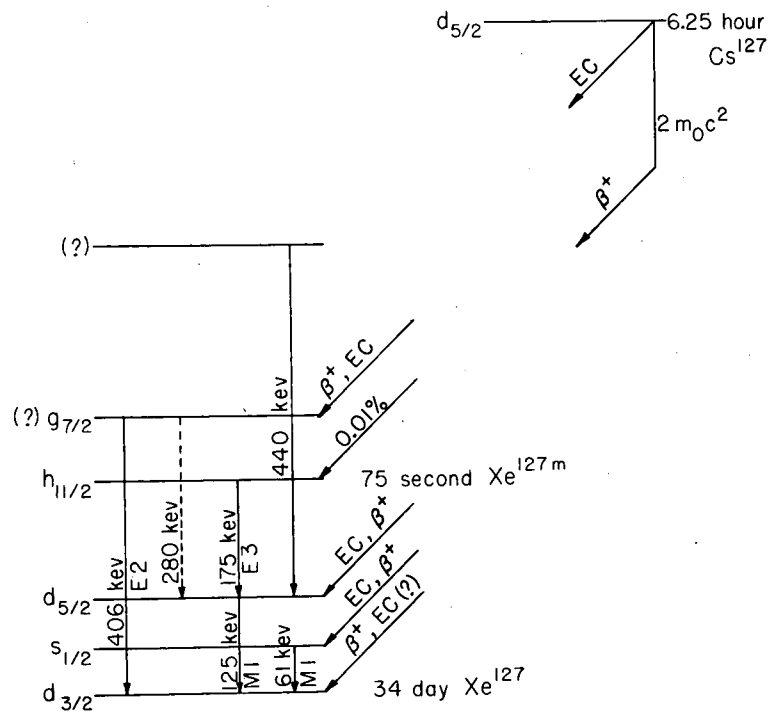

Fig. 9. Yield of 75 second Xe^{127m} from timed milkings of Cs^{127} parent sample.



MU-7076

Fig. 10. Proposed decay scheme for ^{127}Cs .

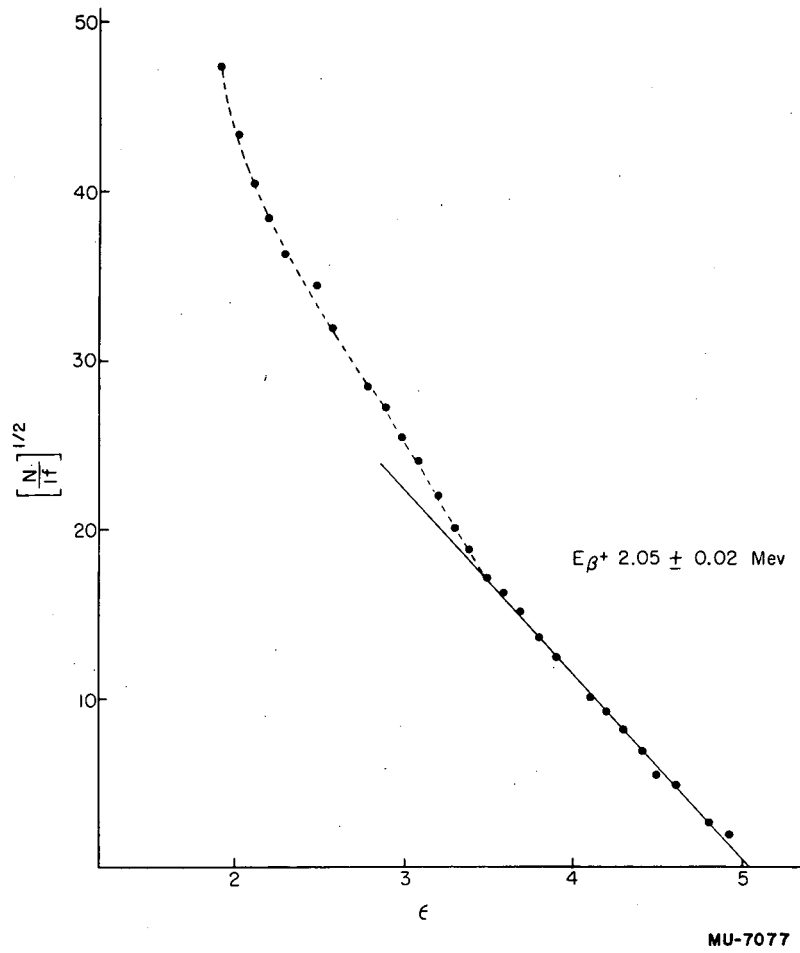
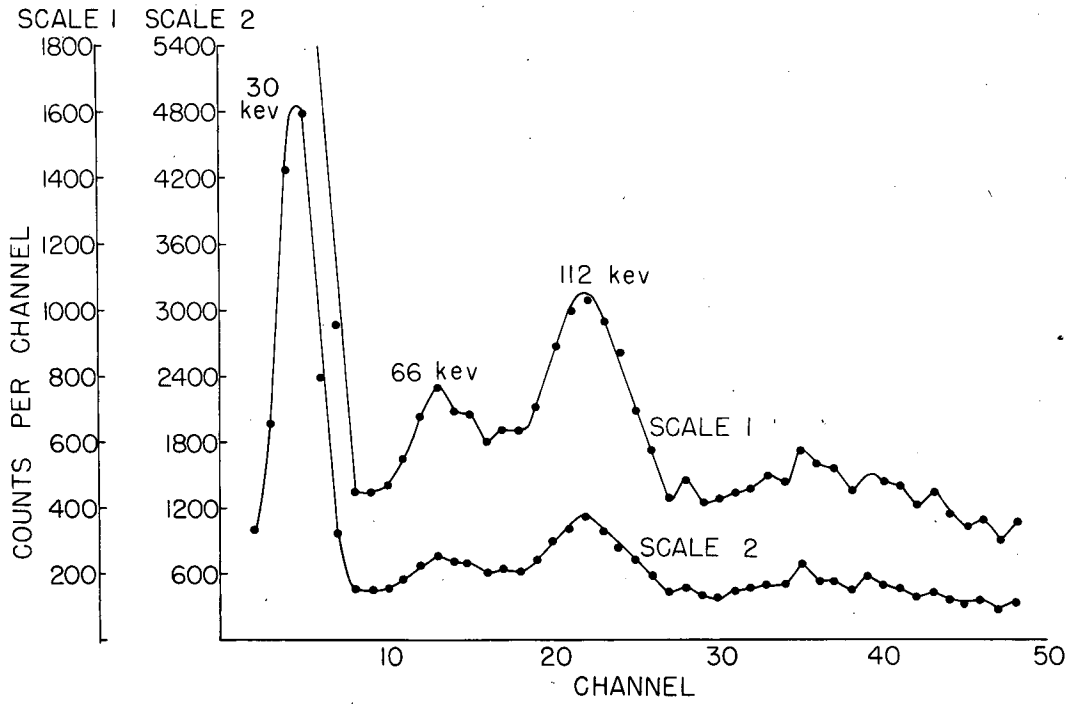

Fig. 11. Fermi-Kurie plot showing endpoint energy most energetic positron in Cs^{125} .



MU-7078

Fig. 12. Gamma spectrum of mass-separated Cs¹²⁵ in 0-250 keV region. The data as replotted on scale 2 show large xenon K x-ray peaks.

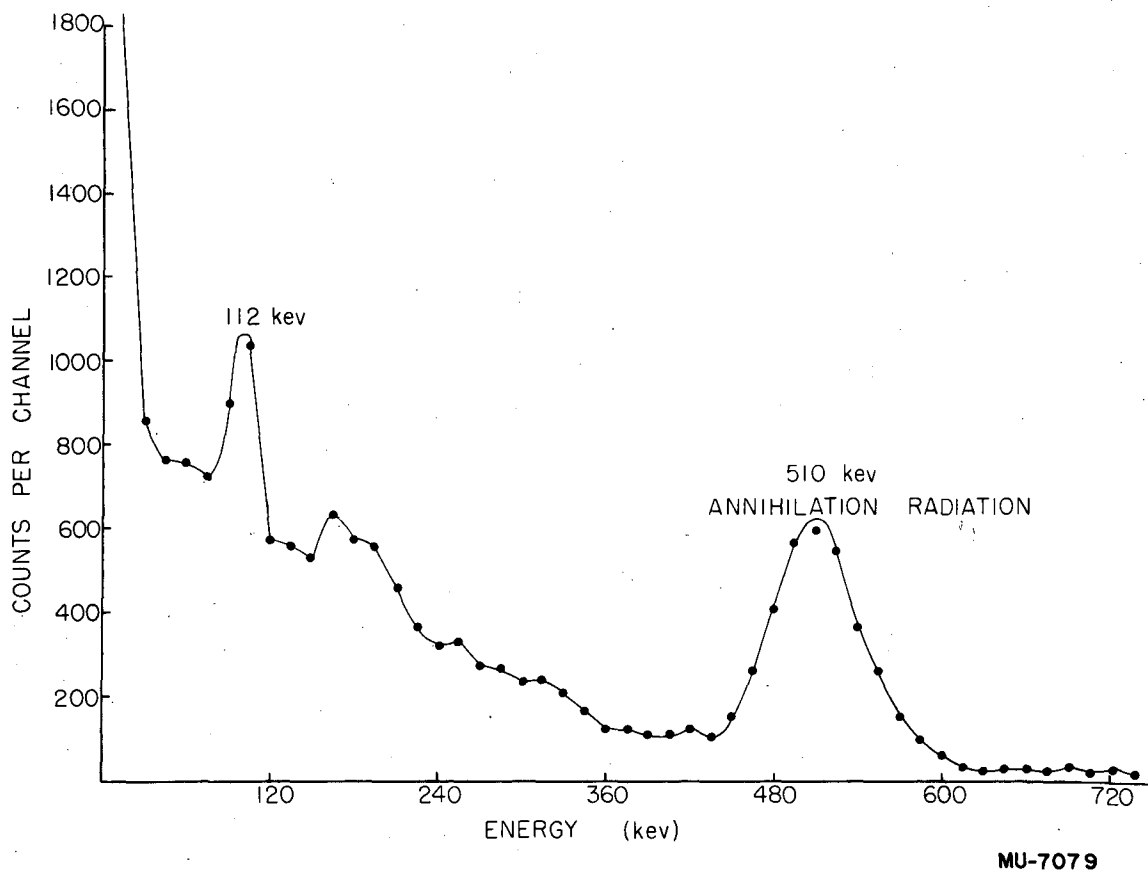
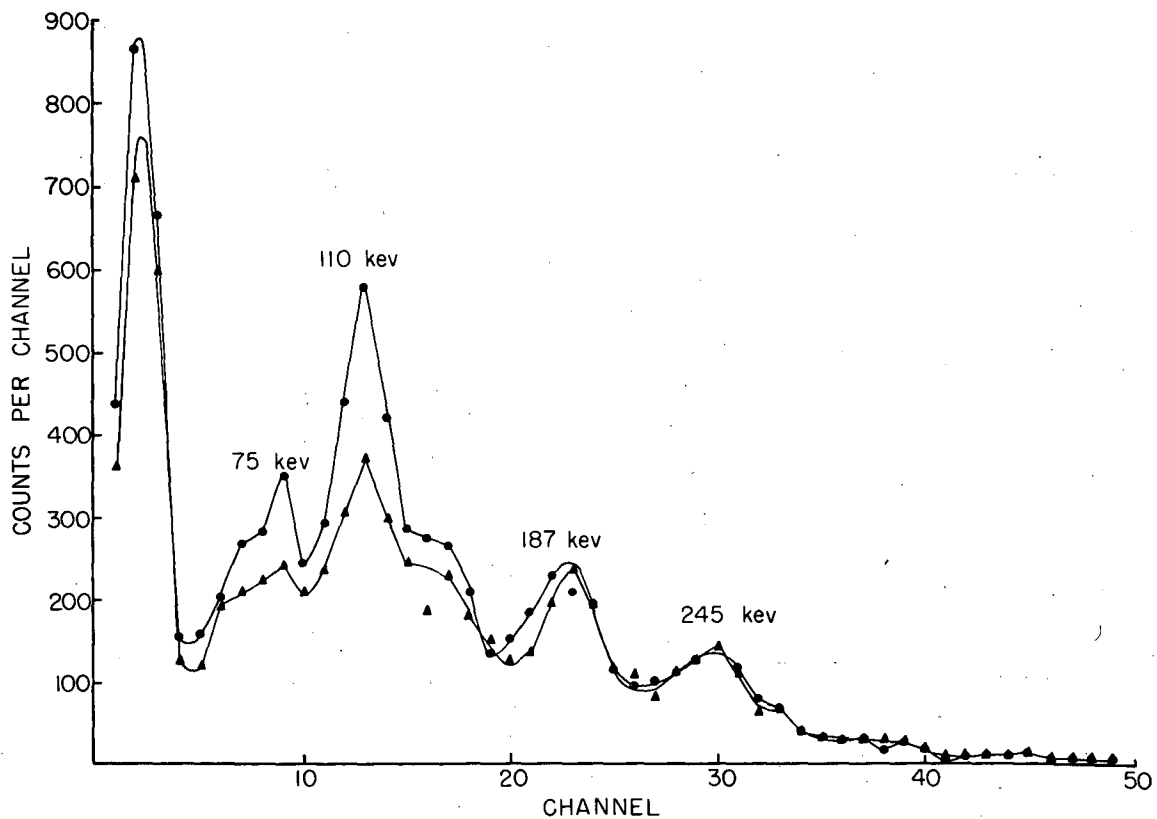

Fig. 13. Gamma spectrum of mass-separated Cs^{125} in 0-600 keV region.

MU-7079



MU-7080

Fig. 14. Gamma spectrum of Xe^{125m} + Xe^{125} daughter activity collected in apparatus of Fig. 6 during one minute growth period. Upper curve is spectrum recorded for first minute after collection; lower curve is for second minute.

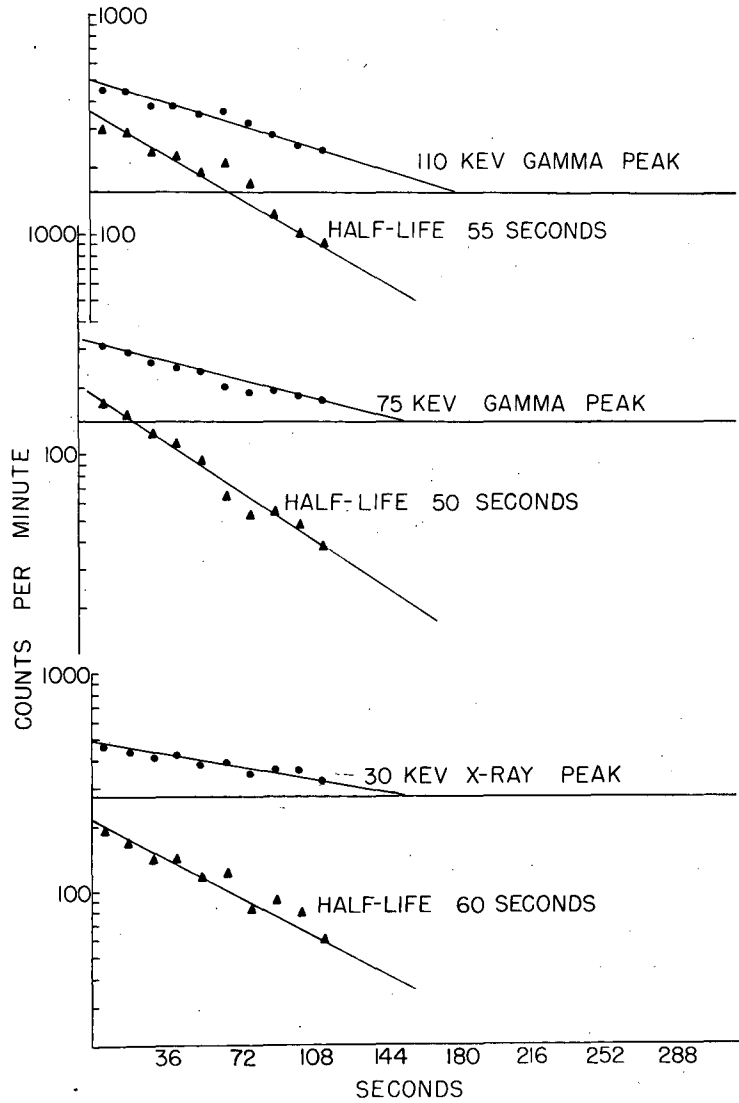
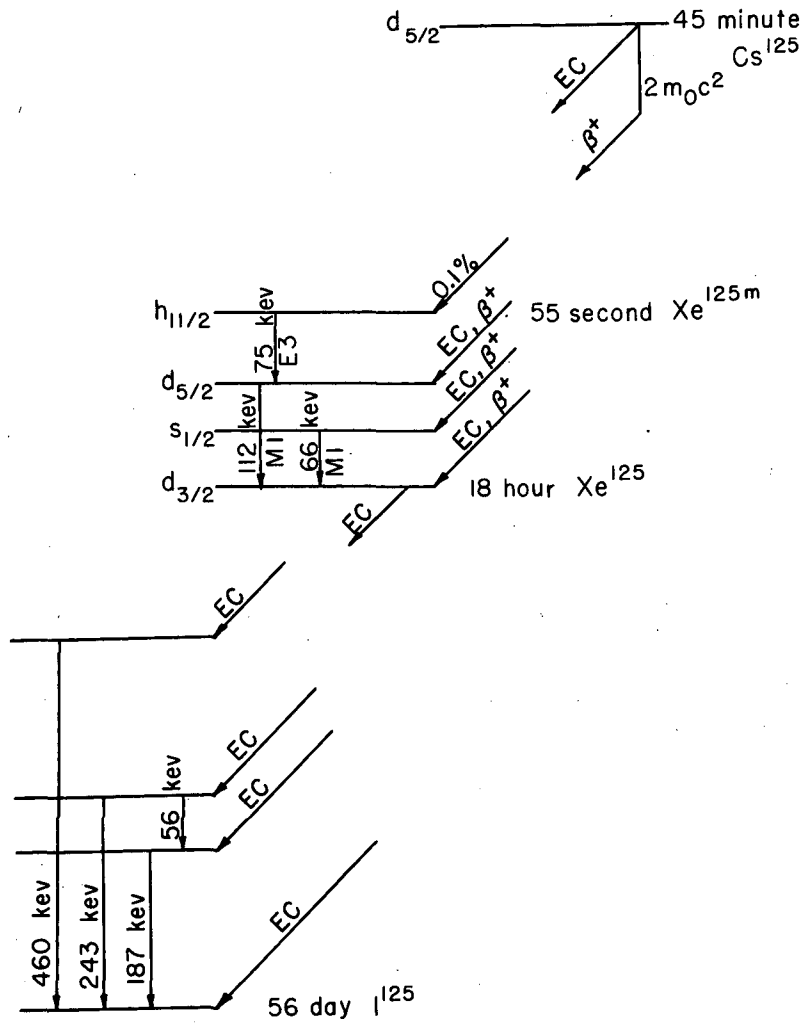
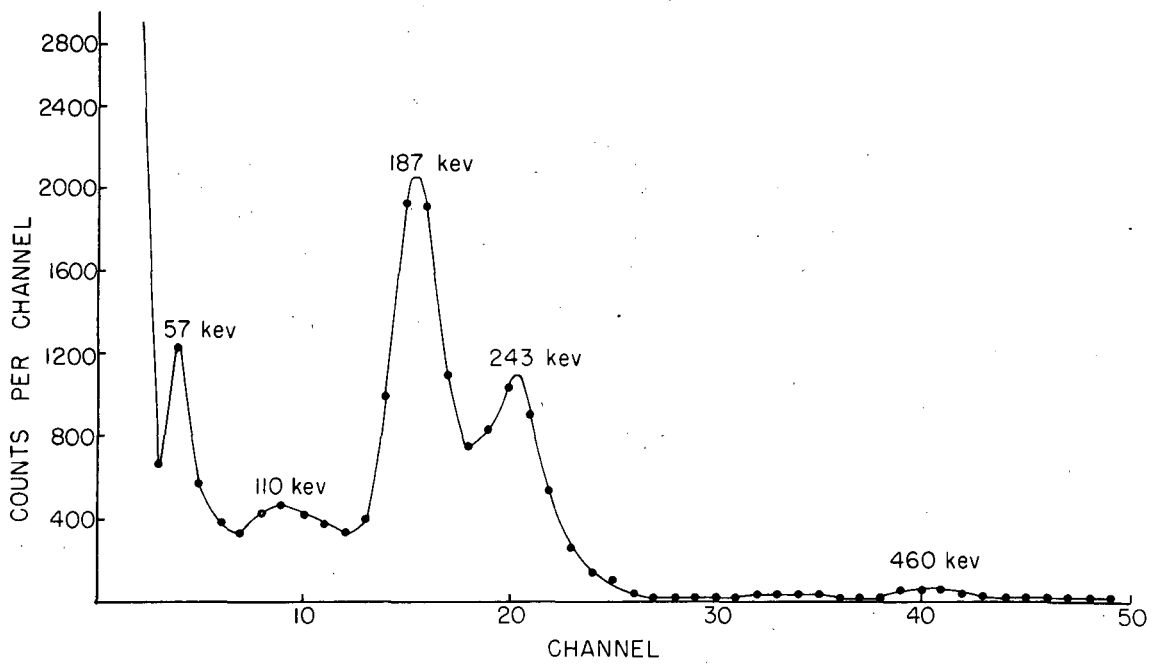

Fig. 15. Decay of gamma rays recorded in 30, 75 and 110 kev peaks during 12 second runs on $Xe^{125m} + Xe^{125}$ daughter activity collected from Cs^{125} source. Resolution shows 55 second decay of Xe^{125m} .



MU-7082

Fig. 16. Proposed decay scheme for Cs^{125} .



MU-7083

Fig. 17. Gamma spectrum of 18 hour Xe^{125} isolated from Cs^{125} and deposited on aluminum foil. Purity of sample was checked by decay.

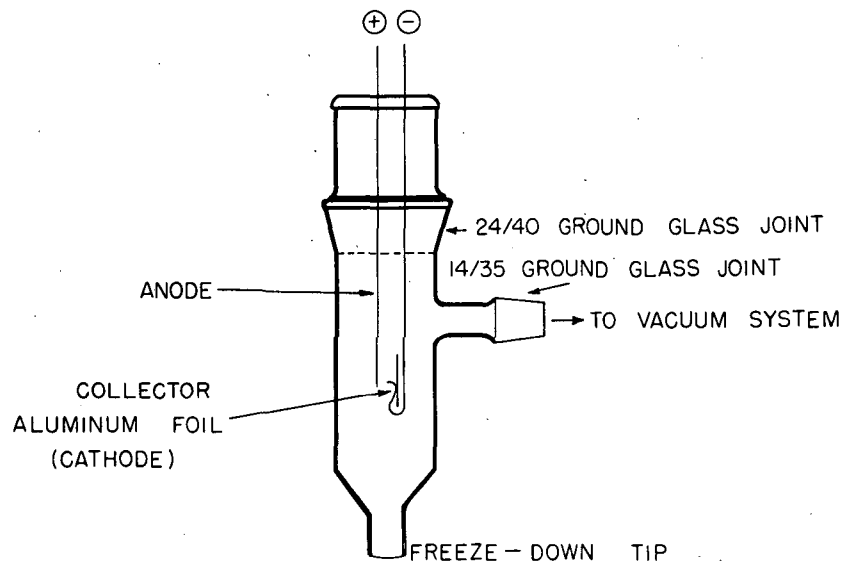

MU-7084

Fig. 18. Glow discharge tube used for collection of xenon activities.