

## **UC Merced**

### **Proceedings of the Annual Meeting of the Cognitive Science Society**

#### **Title**

The Mechanism of Restructuring in Geometry

#### **Permalink**

<https://escholarship.org/uc/item/36w804m5>

#### **Journal**

Proceedings of the Annual Meeting of the Cognitive Science Society, 12(0)

#### **Author**

Ohlsson, Stellan

#### **Publication Date**

1990

Peer reviewed

## The Mechanism of Restructuring in Geometry

Stellan Ohlsson

*Learning Research and Development Center*  
*University of Pittsburgh, Pittsburgh, PA 15260*  
stellan@vms.cis.pitt.edu

**Abstract.** Restructuring consists of a change in the representation of the current search state, a process which breaks an impasse during problem solving by opening up new search paths. A corpus of 52 think-aloud protocols from the domain of geometry was scanned for evidence of restructuring. The data suggest that restructuring is accomplished by re-parsing the geometric diagram.

**Introduction.** A wide variety of problem solving processes have been analyzed in terms of heuristic search (Newell & Simon, 1972). For example, in geometry proofs the geometric theorems (operators) are applied to the mental representation of the diagram (the knowledge state) until the desired proposition (the goal state) has been attained (Anderson, 1981). The stepwise character of heuristic search contrasts with the Gestalt hypothesis that problem solving proceeds through (a) an initial, unsuccessful, attack on the problem, (b) a more or less protracted impasse, and (c) a restructuring of the problem, which is typically, but not necessarily, followed by insight (Ohlsson, 1984a).

Several attempts have been made to reconcile the information processing and Gestalt hypotheses. Simon (1966) proposed that it helps to sleep on a problem, because goal tree information is forgotten faster than problem information. After a pause, a new goal tree is built on the basis of more knowledge about the problem. Langley and Jones (1988) interpret an impasse as a failure to retrieve the relevant problem solving operator. Insight occurs when some *external* stimulus causes enough activation to spread to that operator to allow its retrieval. A related hypothesis claims that insight occurs when an appropriate analogy is retrieved (Keane, 1988). Both the differential rate of forgetting hypothesis and the spread of activation hypothesis require that the problem solver moves attention away from the problem, and so cannot explain insight during *ongoing* problem solving. Several researchers have proposed that problem representations can be improved by the construction of macro-operators (Amarel, 1968; Korf, 1985). Koedinger and Anderson (in press) have proposed the related idea that geometry experts combine geometric theorems into larger inference schemas, called *diagram configuration schemas*, which allow them to find a proof without step-by-step search of the proof space. The macro-operator and diagram configuration hypotheses explain expert performance, but they do not explain insights by novices. All of these hypotheses locate restructuring in the *processes* of problem solving.

In contrast, I have proposed that restructuring involves a change in *the mental representation of the current search state* (Ohlsson, 1984b). A change in the

representation implies that objects, relations, and properties which initially are seen as instances of certain concepts are being re-encoded as instances of other concepts. For example, an object which is initially encoded as a *hammer* might in the course of problem solving become re-encoded as a *pendulum weight*, a *line* may be re-encoded as a *triangle side*, and so on. Re-encoding a search state changes the set of operators which are applicable in that state, and thus breaks an impasse by opening up new search paths. A similar theory has been proposed by Kaplan and Simon (in press) to explain restructuring in the Mutilated Checker Board Problem. The critique by Montgomery (1988) does not touch those aspects of the theory that are of main concern in this paper. The purpose of the present paper is to provide evidence for re-encoding from the domain of geometry, and to propose a mechanism for re-encoding in that domain.

---

Table 1. Geometric theorems acquired by the subjects.

---

*Theorem 1.* Supplementary angles are congruent.

*Theorem 2.* Vertical angles are congruent.

*Theorem 3.* The supplementary angle of a right angle is a right angle.

*Theorem 4.* If two angles and their common side in one triangle are congruent to the corresponding angles and their common side in another triangle, then the two triangles are congruent.

*Theorem 5.* If two sides in a triangle are congruent, then their opposite angles are congruent; and vice versa.

---

**Method.** Three undergraduate psychology students participated in an experimental course in elementary geometry. The experimenter saw each subject individually in sessions that lasted approximately one hour each. The subjects learned basic theorems of plane geometry, the first five of which are shown in Table 1. A typical session began with free recall of previously learned theorems, continued with the introduction of new theorems, and ended with problem solving practice. The subjects had the theorems available during problem solving, and they were instructed to think aloud. The data consist of 52 think-aloud protocols, representing a total of approximately nine hours of problem solving effort. The protocols were scanned for the occurrence of restructuring events. Ten such events were found. The three most informative events will be analyzed below. They illustrate deliberate restructuring, goal driven restructuring, and restructuring in response to a hint.

**Case 1: Deliberate restructuring.** Subject S3 was given the problem in Figure 1 after she had studied Theorems 1-5 (see Table 1). She began by proving that triangles

AED and BEC are congruent, and then entered an impasse. In fragments F65-F67 (see Table 2) she deliberately sets out to *see* the problem from *many viewpoints*. The process of restructuring proceeds through three steps. First, she mentally cuts the figure along the diagonal CA, forming the triangles CDA and CBA (F68-F70). She then mentally cuts the figure along the other diagonal, forming the triangles DCB and DBA (F71-F74). Finally, she keeps one triangle from each pair, as it were, and sets herself the task of proving them congruent (F75-F77). Figure 2 gives a diagrammatic analysis of the process. The geometric objects perceived by the subject are drawn in bold lines, while the rest of the diagram is drawn in broken lines. Restructuring was not followed by insight in this case. The subject worked on the problem for twelve minutes without solving it.

---

Table 2. Protocol excerpt from Subject S3.

---

F65. but perhaps one can see this in some other way also  
 F66. one can perhaps see this from many viewpoints here  
 F67. now we shall see  
 F68. one can see it as  
 F69. CDA and CBA  
 F70. triangles  
 F71. one can see it on  
 F72. DCB and DBA instead  
 F73. yes exactly yes  
 F74. those two  
 F75. well  
 F76. now I can see this in another way  
 F77. CDB and CAD ought to be congruent here in some way

---

**Case 2: Goal-driven restructuring.** S1 was given the problem in Figure 1 as his first problem after studying Theorems 1-5 (see Table 1). S1 misunderstood the goal of the problem to be to prove that angle ADC is congruent to angle BCD. When the protocol excerpt in Table 3 begins, he has proved that angles EDA and ECB are congruent by proving them corresponding parts of the congruent triangles EDA and ECB. He then sets himself the goal of proving that the *remaining parts*, i. e., angles EDC and ECD, are equal (F43). His plan is to prove that they are equal by proving that the *sides* of the triangle EDC are equal (F42-F45). This goal is reformulated as proving that the triangle EDC is *isosceles* (F46-F47). This view of the problem leads to an impasse (F48-F49). Prompted by the experimenter to continue to think-aloud, he states that he is thinking about *the same problem* but from *another angle* (F50-F52): he has re-encoded ED and EC as *lines* (F54). The goal is still to prove them congruent (F53-F55). He suddenly realizes that ED and EC are corresponding *sides* of

the two triangles EDA and ECB, which he has already proved congruent (F56-F61). Figure 3 shows a diagrammatic analysis of the process with perceived geometric objects in bold lines and the rest of the diagram--the background--in broken lines. The subject quickly completed the correct solution.

---

**Table 3. Protocol excerpt from Subject S1.**

---

F42. yes now I am thinking about whether one can prove that these two sides [DE, EC] are equally long  
F43. because if they are then those two angles [EDC, ECD] which are just the remaining parts of those angles which I want to get [ADE, BCD] must be equally long  
F44. so then this and that angle [ADE, BCD] must be equally big  
F45. and then the problem is solved  
F46. so it is now a question of proving that it is isosceles  
F47. that triangle [EDC]  
F48. and that I cannot  
F49. but perhaps one can do it in some other way  
(What are you thinking?)  
F50. well now I am thinking  
F51. well it is the same problem  
F52. but from another angle  
F53. yes if this one  
F54. is those two lines [ED, EC] are equally long  
F55. I am thinking  
F56. yes but they must be  
F57. since they are parts of  
F58. it is congruent  
F59. these two here are congruent [triangles EDA, ECB]  
F60. and it is [ED, EC] corresponding sides in the triangles [EDA, ECB]  
F61. therefore these two sides [ED, EC] are equally long

---

**Case 3: Hint-driven restructuring.** S2 attempted Problem 2 (see Figure 4) after having learned the five theorems in Table 1, plus four others. She decided to prove triangles AED and BEG congruent and quickly reached an impasse. The protocol excerpt in Table 4 begins when the experimenter gives her the hint that there are other pairs of triangles in the figure that might be congruent. She first rejects this suggestion (F113-F115). She then runs through the triangles in the figure (F113-F121), and concludes that there are no other congruent triangles in the figure (F121). She then suddenly sees the triangles AEG and BDA (F123-F124). Figure 5 shows a diagrammatic analysis of the process with perceived geometric objects drawn in bold lines and the rest of the diagram drawn in broken lines. In spite of this restructuring, the subject failed to solve the problem.

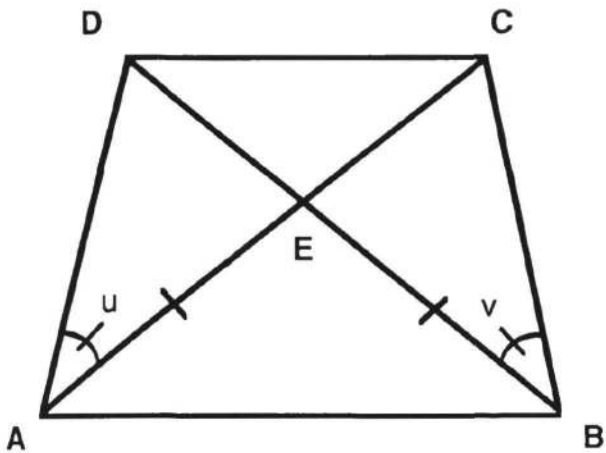

Prove angles ECD and CDE congruent.

Figure 1. Problem 1.

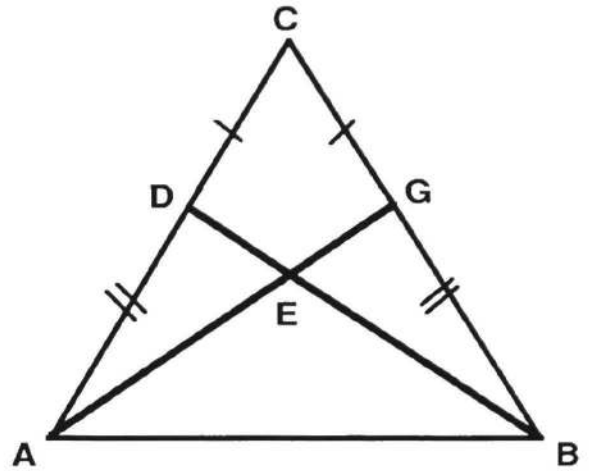

Prove line segments AG and BD congruent.

Figure 4. Problem 2.

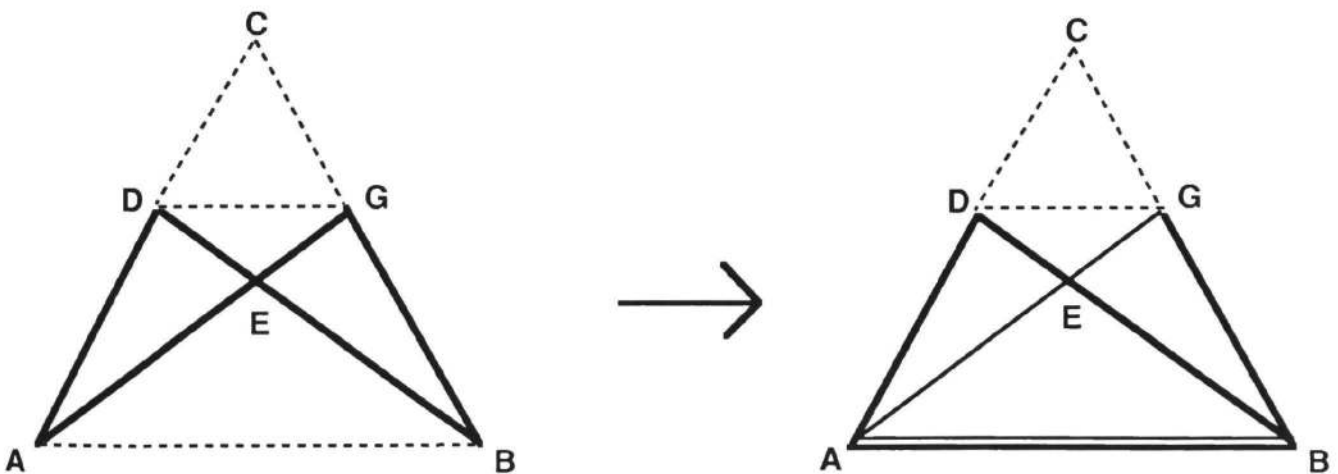

Figure 5. Analysis of S2's re-encoding process. Perceived geometric figures are drawn in bold lines, the rest of the figures in broken lines.

---

Table 4. Protocol excerpt from S2.

---

(What other triangles could be congruent?)

F109. what others

F110 could there be others which are congruent

F111. huh

(That could be. You have now been working the hypothesis that the whole point is to prove that those two triangles [AED, BEG] are congruent.)

F112. yes

(And just now you reached the conclusion that you cannot do that with the information you have. Can you find two other triangles which one can find which one could believe could be congruent?)

F113. congruent exactly alike

F114. no that is impossible there are no others

F115. it cannot be

F116. there are only one other

F117. also hypothetically then this line here

F118. then there are two here

F119. and those two here can surely never be congruent

F120. these two here can surely never be congruent

F121. no I do not understand that

F122. but

F123. now I see it

F124. I have forgotten this one here [AGB or BDA]

---

**Discussion.** The restructuring process revealed in these three protocol excerpts consists in *re-encoding the given figure*. The diagram--the set of lines on the paper--contains within it a large number of different geometric objects (angles, sides, triangles, etc.). Only some of those geometric objects are perceived at any one time. The others recede into the background. In particular, if a line configuration is perceived in one way, then alternative encodings of that same line configuration recede into the background. Restructuring consists of switching to one of the alternative encodings. How does the switching mechanism work? The data suggest that re-encoding is done by *re-parsing* the diagram. During initial problem perception complex objects (e. g., triangles) are constructed out of simpler objects (e. g., lines). This process is a search through a *description space* (Ohlsson, 1984b). Alternative interpretations of the perceptual information are possible, so some choices are made, resulting in a particular encoding of the given diagram. When an impasse forces the problem solver to re-encode the problem, he/she backs up in the description space, dismantles his/her previous encoding, and traverses another path through the description space. This process breaks an impasse by allowing other operators (geometric theorems) to apply to the current state. Restructuring is a rare

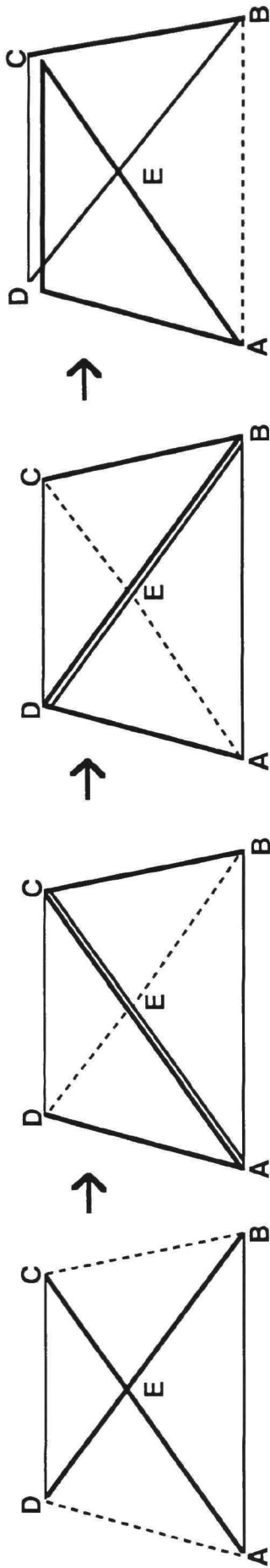

Figure 2. Analysis of S3's re-encoding process. Perceived geometric objects are drawn in bold lines, the rest of the figures in broken lines.

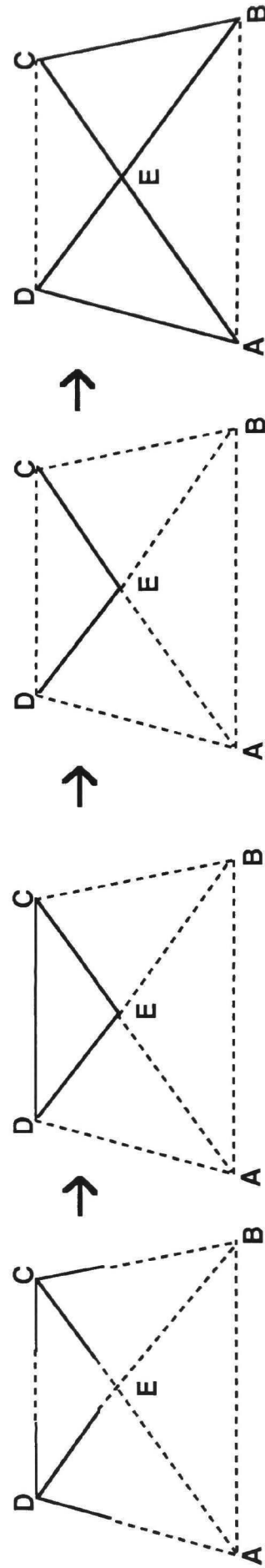

Figure 3. Analysis of S1's re-encoding process. Perceived geometric figures are drawn in bold lines, the rest of the figures in broken lines.



event: There was approximately one restructuring event per hour of problem solving effort in the present study. Restructuring does not necessarily lead to insight: In two of the three excerpts presented above, the subject failed to solve the problem. This study supports the idea that diagram parsing is central in geometry (Koedinger & Anderson, in press), but the validity of the re-parsing mechanism for other domains than geometry remains an open question. For example, a different mechanism seems to be responsible for re-encoding of the Mutilated Checker Board Problem (Kaplan & Simon, in press).

**Acknowledgement.** Preparation of this paper was supported, in part, by ONR grant N00014-89-J-1681. No endorsement should be inferred.

### References

- Amarel, S. (1968). On representations of problems of reasoning about actions. In D. Michie (Ed.), *Machine intelligence. Vol 3.* (pp. 131-171). Edinburgh, UK: Edinburgh University Press.
- Anderson, J. R. (1981). Tuning of search of the problem space for geometry proofs. *Proceedings of the Seventh International Joint Conference on Artificial Intelligence* (pp. 165-170). Vancouver, Canada: University of British Columbia.
- Kaplan, C. A. & Simon, H. A. (in press). In search of insight. *Cognitive Psychology*.
- Keane, M. (1988). *Analogical problem solving*. New York, NY: Wiley.
- Koedinger, K. R. & Anderson, J. R. (in press). Abstract planning and perceptual chunks: Elements of expertise in geometry. *Cognitive Science*.
- Korf, R. E. (1985). *Learning to solve problems by searching for macro-operators*. Marshfield, MA: Pittman.
- Langley, P. & Jones, R. (1988). A computational model of scientific insight. In R. J. Sternberg (Ed.), *The nature of creativity. Contemporary psychological perspectives* (pp. 177-201). Cambridge, MA: Cambridge University Press.
- Montgomery, H. (1988). Mental models and problem solving: Three challenges to a theory of restructuring and insight. *Scandinavian Journal of Psychology*, 29, 85-94.
- Newell, A. & Simon, H. A. (1972). *Human problem solving*. Englewood Cliffs, NJ: Prentice-Hall.
- Ohlsson, S. (1984a). Restructuring revisited. I. Summary and critique of the Gestalt theory of problem solving. *Scandinavian Journal of Psychology*, 25, 65-78.
- Ohlsson, S. (1984b). Restructuring revisited. II. An information processing theory of restructuring and insight. *Scandinavian Journal of Psychology*, 25, 117-129.
- Simon, H. A. (1966). Scientific discovery and the psychology of problem solving. In *Mind and cosmos: Essays in contemporary science and philosophy. Vol. III.* (pp. 22-40). Pittsburgh, PA: University of Pittsburgh.