

# Lawrence Berkeley National Laboratory

## Recent Work

**Title**

NEUTRAL BEAM INJECTION SYSTEMS FOR REACTORS

**Permalink**

<https://escholarship.org/uc/item/37f2c1bz>

**Author**

Pyle, R.V.

**Publication Date**

1983-06-01



# Lawrence Berkeley Laboratory

UNIVERSITY OF CALIFORNIA

RECEIVED  
LAWRENCE  
BERKELEY LABORATORY  
AUG 10 1983  
LIBRARY AND  
DOCUMENTS SECTION

## Accelerator & Fusion Research Division

To be presented at the 7th Symposium (1983 International) on Ion Sources and Ion Assisted Technology (ISIAT '83) and the 4th International Conference on Ion and Plasma Assisted Techniques (IPAT '83), Kyoto, Japan, September 12-16, 1983

NEUTRAL BEAM INJECTION SYSTEMS FOR REACTORS

R.V. Pyle

June 1983

**For Reference**  
Not to be taken from this room

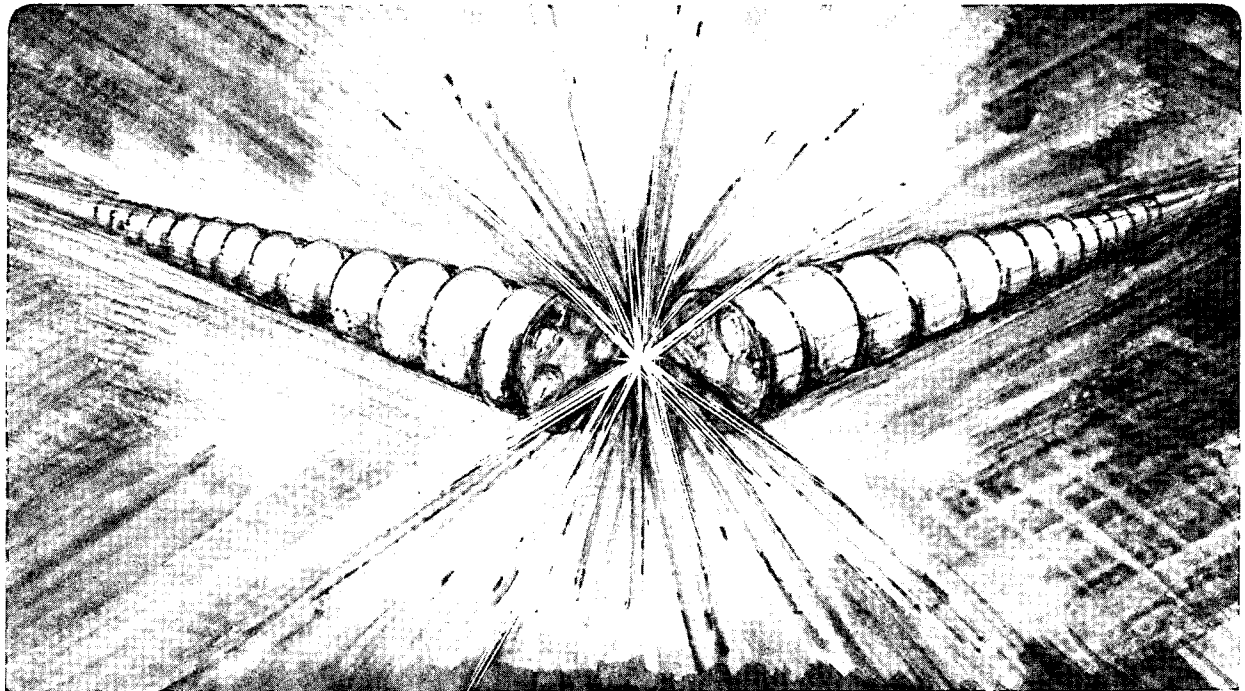

LBL-16279  
c.1

## **DISCLAIMER**

This document was prepared as an account of work sponsored by the United States Government. While this document is believed to contain correct information, neither the United States Government nor any agency thereof, nor the Regents of the University of California, nor any of their employees, makes any warranty, express or implied, or assumes any legal responsibility for the accuracy, completeness, or usefulness of any information, apparatus, product, or process disclosed, or represents that its use would not infringe privately owned rights. Reference herein to any specific commercial product, process, or service by its trade name, trademark, manufacturer, or otherwise, does not necessarily constitute or imply its endorsement, recommendation, or favoring by the United States Government or any agency thereof, or the Regents of the University of California. The views and opinions of authors expressed herein do not necessarily state or reflect those of the United States Government or any agency thereof or the Regents of the University of California.

NEUTRAL BEAM INJECTION SYSTEMS FOR REACTORS

R.V. Pyle

Lawrence Berkeley Laboratory  
University of California  
Berkeley, California 94720

June 1983

This work was supported by the Director, Office of Energy Research, Office of Fusion Energy, Development and Technology Division, of the U.S. Department of Energy under Contract Number DE-AC03-76SF00098.

## NEUTRAL BEAM INJECTION SYSTEMS FOR REACTORS\*

R. V. Pyle

Lawrence Berkeley Laboratory, Berkeley, California 94720

Abstract

Increasing effort is being put into engineering designs of reactors and reactor-like magnetic confinement experiments. A central question concerns the methods of heating, fueling, and maintaining the plasmas, functions that primarily are now performed by neutral beams. Planning in the U.S.A. does not include the use of neutral beams on tokamaks in the 1990's and beyond. Tandem mirrors, however, will use energetic beams ("sloshing ion" beams) in the end plugs to produce electrostatic potentials that will confine plasma ions. These systems will be based on the production, acceleration, transport, and neutralization of negative hydrogen-ion ( $D^-$ ), multiampere beams with energies of 200-to 500-keV. In addition, lower-energy D and T beams may be used. These systems must operate steady state, with high reliability, and be compatible with radiation from a D-T burning plasma.

Planning for fusion reactors may change in the future, and tokamaks, tandem mirrors, and perhaps other confinement geometries eventually may use neutral beams for other functions, such as heating; in this case it may be desirable to inject polarized nuclei to adjust the reactivity and directionality of fusion products. In any event, all reactor experiments may use high-energy neutral beams for diagnostics.

1. Introduction

It is often and correctly said that intense neutral beams are, at present, the best way to heat and fuel magnetically-confined fusion plasmas. They also are used to diagnose plasmas, adjust electric potentials in tandem mirror experiments, and could be used to maintain toroidal currents in tokamaks. When we look fifteen or more years into the future at reactor-like experiments, the planning in the United States of America (the content of this paper will be restricted to research and development activities in the U.S.A.) shows a considerably reduced role for neutral beams. This is largely due to expectations that high-frequency power can do many of the functions better, cheaper, and more reliably in both tokamak and tandem-mirror devices. In addition, energetic arguments indicate that gas puffing or pellet injection are more appropriate for fuelling. Nevertheless, it is expected that neutral beams will be used in reactor-like devices for maintaining the required plasma conditions in critical regions, and for diagnostics; the neutral beam planning described here is oriented toward these reactor applications.

The emphasis at this congress mainly is on ion sources, rather than systems in which the ion source is a small part, but the ion source and the rest of the system are so interdependent that they cannot be considered separately. A good example is the injection system of the Tokamak Fusion Test Reactor (TFTR) which is just becoming operational at the Princeton

---

\*This work was supported by the Director, Office of Energy Research, Office of Fusion Energy, Development and Technology Division, of the U.S. Department of Energy under Contract No. DE-AC03-76SF00098.

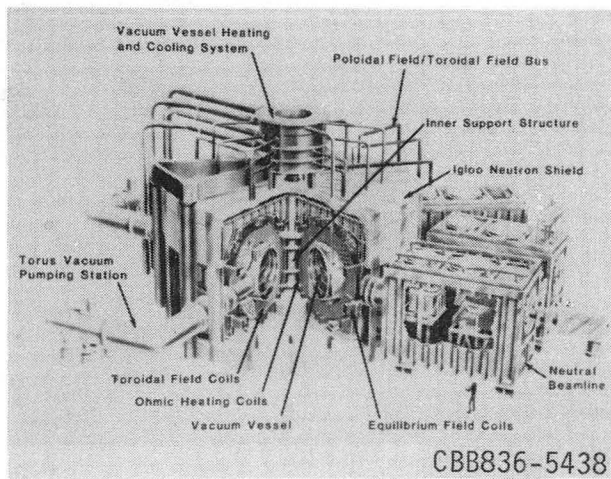

Fig. 1 An artist's conception of the Princeton Plasma Physics Laboratory TFTR experiment.

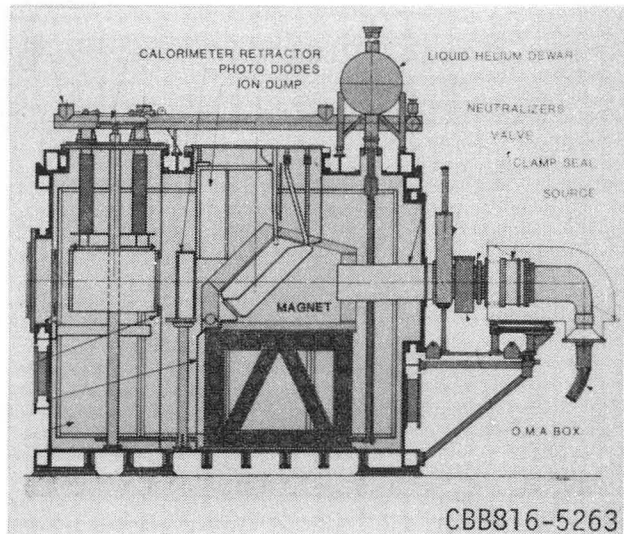

Fig. 2 Schematic of one of the positive-ion-based neutral beam systems for TFTR.

Plasma Physics Laboratory, and is expected to produce a reactor-grade plasma in a few years. An artist's conception of the experiment is shown in Figure 1. There are four neutral beam lines, each with three ion sources, that are expected to inject a total of about 20 MW of 120 keV, and a somewhat smaller power of 40 keV and 60 keV,  $D^0$  atoms into the plasma. One of the beam lines is shown schematically in Fig. 2. The size and shape of the beam line components (cryopumps, beam dumps, etc.) are determined in part by ion source properties such as gas efficiency, atomic- and molecular- ion fractions, and ion temperature. Conversely, the required plasma uniformity in space and time, plasma density, ion species mix, etc., in the ion source must be compatible with the rest of the beam line - tokamak system. The interdependence will be even stronger in neutral beam systems for future tandem mirror reactors.

Table I shows some of the neutral beam parameters that have resulted from recent representative fusion reactor studies. Although these particular devices may never be built, the studies show that future neutral beams must have very high energies. In the case of a tokamak reactor the energy would have to be high enough that the neutral beam could penetrate to the center of the large, dense plasma. For a tandem mirror reactor, the energy must be several hundred kilo-electron-volts in order to establish sufficiently high potential hills for good ion confinement in the plugs (Figs. 3 and 4)[1]. As a result of the need for these very high energies, neutral beam planning for reactors is based entirely on systems that produce, accelerate, transport, and neutralize negative hydrogen, deuterium and tritium ions.

There are other important requirements, in addition to beam energy and neutralization efficiency, including low beam divergence, low impurity content, acceptable cost, and high reliability. Although geometric constraints are not obvious from Figures 1 and 3, the requirement that multi-megawatt beams from an ion source tens of meters away must pass through a complex magnet system means that most of the beam power must be contained within an angle substantially less than one degree. (The penalties for exceeding the designed divergence are melting of a magnet cover and/or production of neutral gas in a sensitive region.) The angular divergence is determined, in part, by the transverse ion energy, and by the plasma uniformity, in the ion source.

Table I. Representative Neutral Beam Requirements for Fusion Reactors

Class of Machine	Representative Machine	Beam Application	Energy (keV)	Power into the Plasma (MW)
	Tokamak ETR (FED-A)	Heating Current drive	400-800	40-50
			Steady state 400-800	
Next-generation	Mirror ETR	Plug cell potential barrier	Steady state 475	9.5
			Internal Transformer: 175-400	
Reactor	MARS Tandem mirror	Anchor cell potential barrier	400	40
			Steady state 1000-2000	
			Internal: Transformer: 400	60
			Steady state 475	18

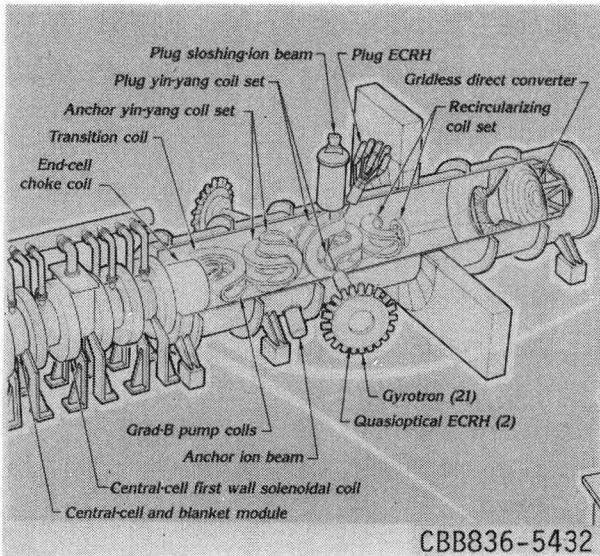

Fig. 3 Schematic diagram of the MARS tandem mirror reactor.

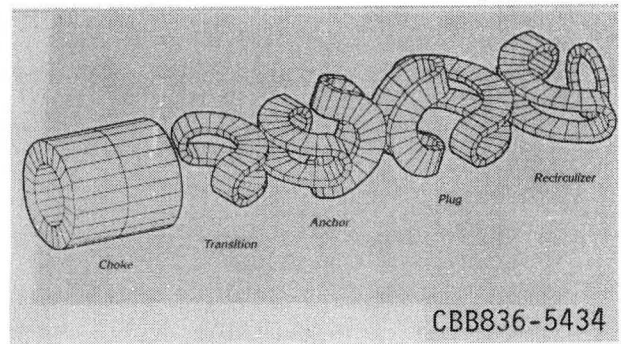

Fig. 4 Magnetic field coils in one end of the MARS tandem mirror reactor.

The reason for using negative ions is apparent from Fig. 5. The maximum efficiency for conversion of high energy  $D^+$  beam to a  $D^0$  beam is unacceptably low, whereas a  $D^-$  beam can be neutralized with an efficiency of at least 60% at arbitrarily high energies. Fig. 5 also shows that molecular-positive ions systems could have useful conversion efficiencies at high energies, and operation of a large ion source with a high  $D_2^+$  fraction has been demonstrated. However, it is necessary to accelerate the molecular ions to two or three times the desired  $D^0$  energy, which is not easy, and the efficiency would still be much lower than could be obtained with negative-ion beams.

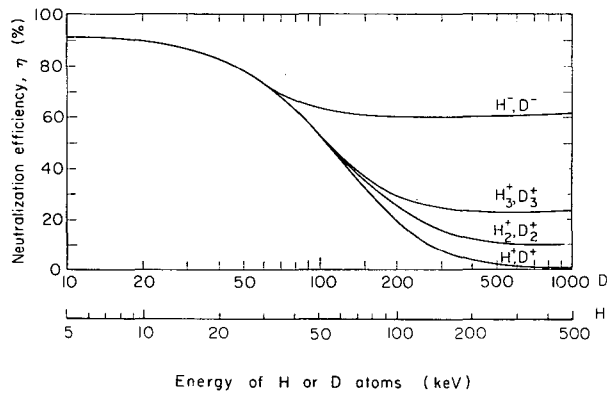

Fig. 5 Maximum efficiency of conversion of ions to neutrals in gas neutralizer.

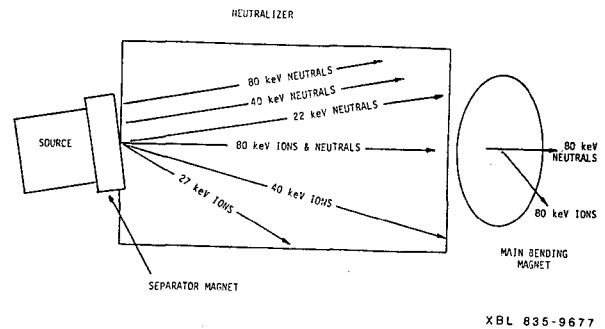

Fig. 6 Momentum analysis to remove impurities and lower-energy  $D^0$  components in a MFTF-B beamline.

Large amounts of impurities can not be tolerated in fusion reactors. A one percent oxygen impurity can double the radiation loss from the plasma; heavier impurities are much worse. Much smaller impurity fractions will be unacceptable in tandem mirror end cells, where because of their high charge states, they have large cross sections for scattering deuterium ions in such a way as to reduce the plasma confinement. A straight forward way to eliminate impurity ions would be by momentum analysis (Fig. 6).

Like all other fusion reactor components, parts of the neutral beam systems must operate reliably, and for long periods of time, in high radiation fields. Neutrons will activate and degrade components, and might release gas from cryopumps; X-rays and  $\gamma$ -rays may cause electrical breakdowns. Consequently, it will be very desirable to keep as much of the system as possible out of the high-radiation regions.

Everyone's goal is the development of a fusion reactor using advanced fuels, which means fuels that produce minimum amounts of nuclear radiation. A deuterium-tritium mixture is the easiest to burn, but produces the most nuclear activation from its 14 MeV neutrons. A pure deuterium fuel produces 2.5 MeV neutrons, and 14 MeV neutrons. A pure deuterium fuel produces 2.5 MeV neutrons, and is somewhat cleaner, but more difficult to use in fusion, because of the higher temperatures required. Best of all, from an environmental viewpoint would be a plasma consisting of the mixture p-"B, which produces only charged reaction products; this fuel requires even better plasma conditions, which seem too difficult for us to achieve soon.

Even without exotic fuels, there may be things that can be done to improve conditions in a reactor. An interesting new topic that presently is being explored is the use of fuels whose nuclei have been polarized. Polarization, if it can be produced and maintained long enough, can have two effects: the reaction cross sections can be increased or decreased, and the direction in which the reaction products (alphas or neutrons, for example) are emitted can be adjusted. At present energetic neutral beams are considered to be the least desirable of the three ways (neutral beams, gas puffing, and pellet injection) to fuel the plasma of an ignited reactor, because of the large amount of kinetic energy that they carry. Whatever, the outcome, this is a very interesting area of applied physics: How can large amounts of polarized deuterium and tritium be made? What is the probability of depolarization when a plasma ion diffuses to the vacuum wall, and then returns to the plasma?



## 2. System Approaches

Although it was stated previously that neutral beam systems for reactors probably will be based on negative ions, it will be useful to describe a positive ion system first, because that is where we have nearly all of our experience.

### Positive Ion Systems

A typical positive-ion system, such as the TFTR beam line shown in Fig. 2, is indicated schematically in Fig. 7. A moderately dense plasma ( $n_i n_e > 10^{12} \text{ cm}^{-3}$ ) is produced by a d.c. discharge in a chamber containing hydrogen or deuterium at low pressure, typically 1-10 mtorr. Following the plasma source is a four electrode accelerator with multiple slots in a 10 cm x 40 cm array.

Ions and neutral gas from the plasma generator pass through the accelerator into the neutralizer. The neutralizer is a region about two meters long, which contains hydrogen or deuterium gas at an average pressure of a few millitorr, i.e., the accelerated ions enter a region containing about  $10^{16}$  molecules  $\text{cm}^{-2}$ , in which neutralization by electron capture can occur. Molecular ions also produce neutrals by collisional dissociation, and/or electron capture; consequently the neutral beam contains three energy groups:  $\text{D}^+$  ions produce neutrals with the full energy of the accelerator,  $eV_0$ ,  $\text{D}_2^+$  ions produce neutrals with energies of  $1/2 eV_0$ ,  $\text{D}_3^+$  ions produce  $1/3 eV_0$  neutrals. Only the full energy neutrals penetrate to the center of the tokamak plasma, so it is desirable to maximize the  $\text{D}^+$  fraction of the accelerated ion beam. Substantial improvements have been made since the first TFTR ion source was built five years ago. At that time the  $\text{D}^+$ ,  $\text{D}_2^+$ ,  $\text{D}_3^+$  ions were in the proportions 65:25:10. Two years later they were 75:15:10, and sources have now been operated on test stands with  $\text{D}^+$  fractions approaching 90%.

The remaining part of the neutral beam system, by far the largest and most expensive part, consists of components to separate the neutral and residual ion beams, cryogenic vacuum pumps, diagnostics, power supplies, and computers for data acquisition and control. There isn't space to discuss these here.

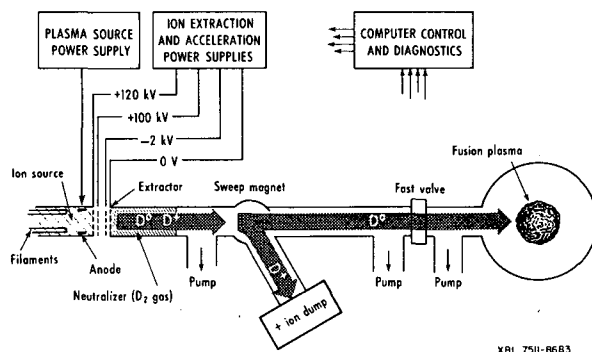

Fig. 7 Schematic of a positive-ion-based neutral beam system.

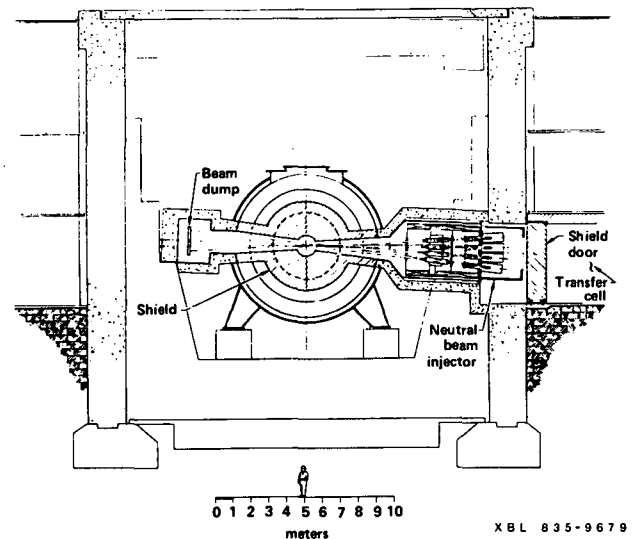

Fig. 8 Cross section of the central cell of a tandem mirror reactor heated and fuelled by neutral beams.

As indicated in Fig. 8, in present systems there is a line-of-sight path down the beam lines. This may be a tolerable situation for pulsed, low-duty-cycle D-T burners such as TFTR and MFTF-B will be for short experiments.

### Negative Ion Systems

Negative-ion-based systems for reactors will have the same basic elements as are shown in Fig. 7, plus a way of transporting the ion beam through the reactor shielding so that most of the components will not be exposed to high radiation. The individual components, however, will be quite different from those described in the previous section.

In Fig. 9 we show a schematic of a negative-ion-based neutral injector, as it is presently conceived. Negative ions from a source are accelerated to moderate energy, 80-150 keV. The negative ion beam is then transported through a pumping section to remove gas from the system and minimize beam losses due to stripping. This transport section matches the beam characteristics to those required by the final accelerator that increases the beam energy to the final value, which may be 400 keV - 2 MeV. After final acceleration, the beam is transported through a maze in the neutron shielding, then passes into a neutralizer (a photoneutralizer is shown), where the negative ions are converted into neutral atoms. There are three well-known ways to make negative ions in ampere amounts [2]. The first is double electron capture in a metal vapor, such as sodium or cesium; this approach is no longer being developed in the U.S.A. In the present programs,

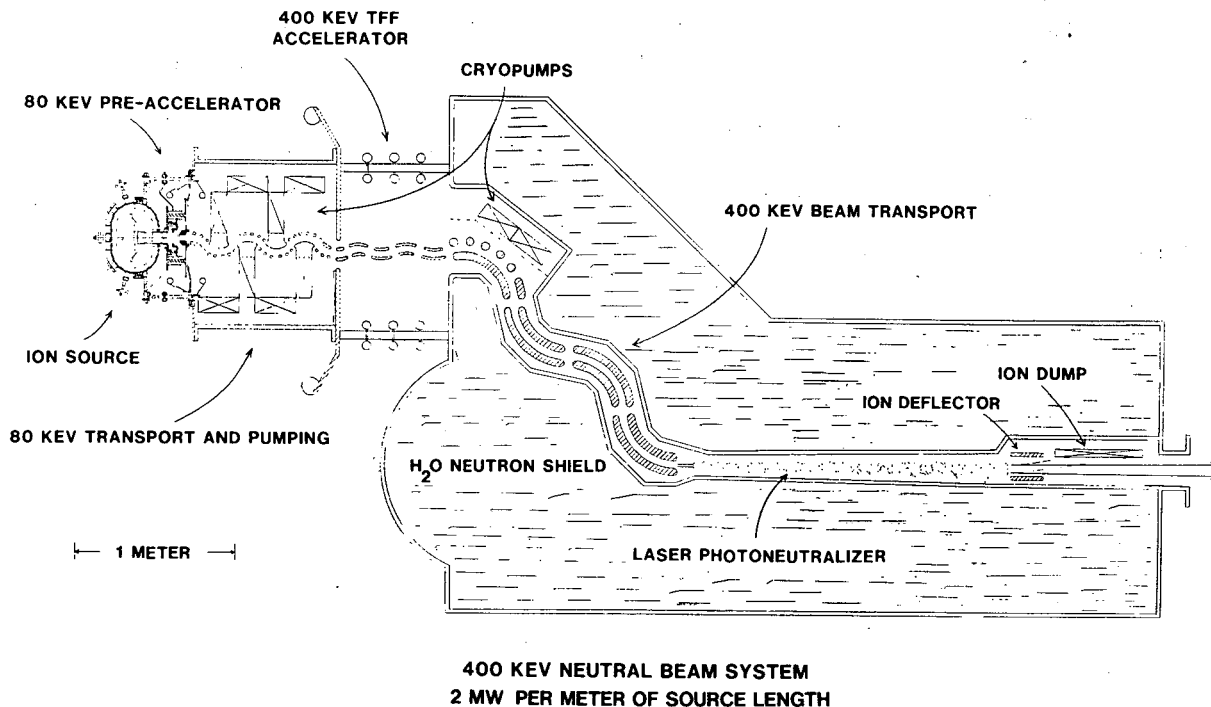

XBL 8211-7449

Fig.9. Schematic diagram of a 400 keV negative-ion-based neutral beam system with the ion source and accelerator outside of the reactor radiation vault.

the negative ions are produced on a low work function surface imbedded in a hydrogen plasma. The low work function is obtained by introducing cesium into the discharge, where it circulates to and from the negative ion producing surface; it has been demonstrated that the negative ion production is highest when the work function is lowest, which implies a coverage of a fraction of a monolayer. One ampere, steady state low energy beams have been produced in this way. While this technique is satisfactory, the use of cesium makes the system more complicated than it otherwise would be. Present research on the ways that negative ions are formed in the volume of a pure hydrogen plasma suggests that it may be possible to develop suitable sources without using cesium; ions produced within the plasma also would permit better beam optics. There is a possibility, looking better each day, that sufficient negative ions can be produced and extracted from a pure hydrogen or deuterium plasma. The proposed formation mechanism is dissociative attachment of low-energy electrons to vibrationally excited  $H_2$  molecules.

To provide high average currents throughout the system, the use of dc accelerators is preferable to rf; the goal is therefore to push dc acceleration to the highest practical limit. Accelerators employing strong focussing offer the advantages of high current-carrying capability, tolerance of stray or poorly optimized beam, and (probably) a reduction in the probability of breakdown, because of the predominantly transverse electric fields. To provide optimum matching between presently conceived ion sources and neutralizers, sheet beams one or two meters high and a few centimeters wide are very desirable.

The most promising candidate for a strong-focussing dc accelerator that produces a sheet beam uses the Transverse Field Focussing (TFF) principle [3] the beam encounters transverse electric fields (applied by curved metal electrodes) that alternate in direction along the beam and focus the beam in the transverse direction. The beam can be accelerated by applying a potential difference between opposing pairs of plates along the accelerator; a schematic of a TFF accelerator is shown in Fig. 10. This type of geometry offers a good match to sources which can produce a sheet beam, and to a laser photoneutralizer, which requires a sheet beam for optimum efficiency. Choice of a sheet beam over an array of cylindrical beamlets, such as can be produced by the ESQ (Electrostatic Quadrupole) accelerator [3], while desirable, is not essential; we have adopted the sheet beam configuration, however, for development.

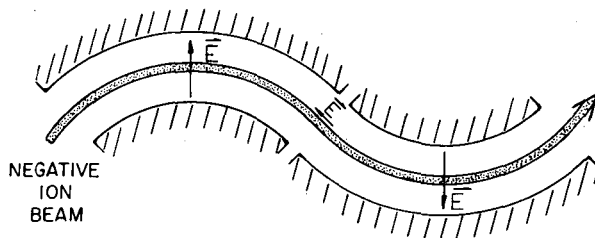

XBL 836-10436

Fig. 10 Schematic drawing of the transverse field focussing (TFF) concept.

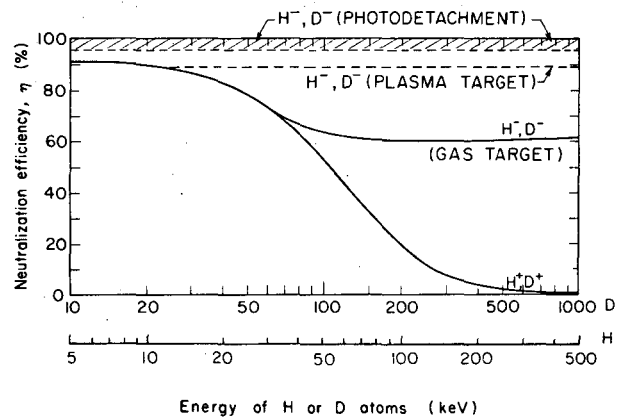

XBL 827 - 933

Fig. 11 Efficiency of converting  $H^-$  and  $D^-$  ions to neutrals in gas, plasma, and photodetachment neutralizers.

An important new feature of conceptual negative-ion-based neutral beam systems is that the TFF, or other, strong-focussing principle can be used to transport an already accelerated beam of negative ions around corners to eliminate direct streaming of particles through the transport system. This feature can be applied with advantage in two areas of beamline design; first, a TFF transporter can be used to transport an intermediate energy (80-150 keV, typically) beam through a maze in a differential pumping section, and second, the same concept can be used to transport the full energy beam through a maze in the neutron shielding. The first application reduces the pressure in the high voltage accelerator to minimize beam loss by premature stripping and also provides a means of matching the beam emittance to the high voltage accelerator; the second provides a neutron trap to reduce the neutron flux through the beam duct to acceptable levels. The conceptual design for a 400 keV beamline, shown in Fig. 9, utilizes TFF transporters.

The accelerated and transported negative ion beam may be neutralized in a gas target, a plasma target, or a photodetachment cell. The maximum efficiency of converting negative ions to neutral atoms, Fig. 11, is highest for photodetachment, in principle approaching 100%, which is the reason that we have chosen to develop this technique. Aside from giving the best overall efficiency, it is very desirable to minimize the un-neutralized fraction of the emerging beams in order to reduce heat transfer requirements.

Whether or not neutral beams are used to create or improve hot plasmas in future upgrades and reactors, powerful neutral beams are, and probably will be, used to help diagnose what conditions exist in a hot plasma. For example, hydrogen beams that are modulated to improve the signal to noise, provide a charge exchange medium for converting plasma ions to neutrals that can leave the plasma and be momentum analyzed. A variation of this has been proposed [4] recently for measuring the alpha-particle energy distribution in a burning D-T plasma. In this scheme, ultraviolet radiation emitted after an alpha-particle captures an electron from a beam hydrogen atom moving with approximately the velocity can be detected outside of the confined plasma. An approximately one-megawatt, variable energy beam with a maximum energy of about 900 keV will be required.

### 3. Positive-ion Systems Status

Present positive-ion systems experiments, PLT, PDX, TMX-U and DIII, use injectors with approximately 0.5 second pulse capability at energies of 80 keV or less. The TFTR experiment now starting will have 120 keV, 0.5 second injectors with a total of about 18 MW 120 keV of neutral deuterium incident on the plasma [5]. The MFTF-B tandem mirror experiment at LLNL will require many megawatts of 10 keV beams with 30 second pulse lengths. The main development goal in the positive ion program has been, for the past several years, the redesign and testing of components and systems that can handle the large heat loads of the 30 second systems. Two "magnetic bucket" design approaches are being tested, one using filaments [6], the other using hollow cathodes [7]. Both plasma sources are being tested with suitable accelerators; this is necessary because a critical part of the operation is the ability to handle power in the electron beam produced by ionization of gas inside of the electrode structure; this electron beam is accelerated into the plasma source. The accelerators used with these plasma sources are four-electrode, multi-aperture structures using long slots [8] or circular holes [9]. These configurations are shown in Figures 12 and 13. Because of test stand limitations, neither module has been tested to the design specifications, but both have operated at close to full power for many seconds, i.e. longer than any thermal time constant. Consequently, we

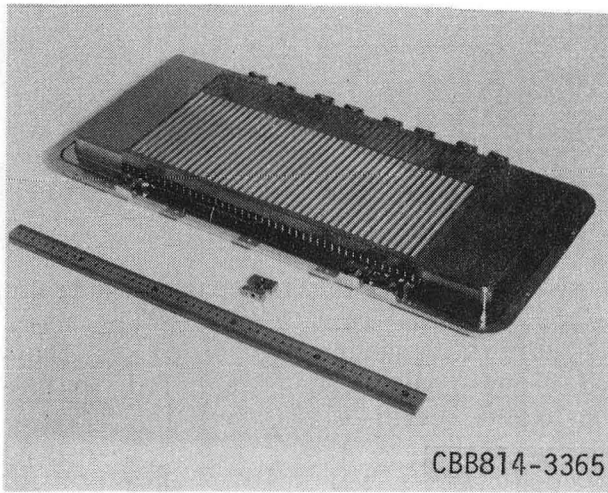

Fig. 12 "Source" electrode of the four-electrode, 80 kV, 10 cm x 40 cm long-pulse LBL accelerator.



Fig. 13 Electrode of the four-electrode, 80 kV, 13 cm x 43 cm long-pulse ORNL accelerator.

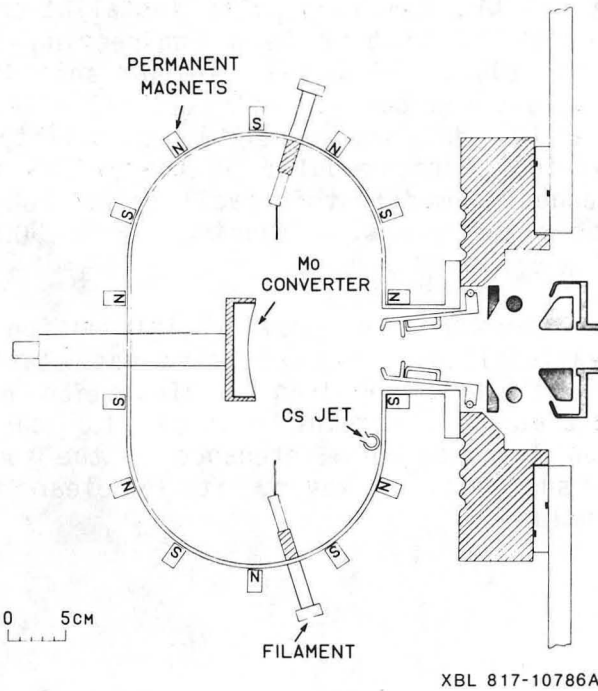

Fig. 14 Schematic diagram of LBL surface production negative-ion source.

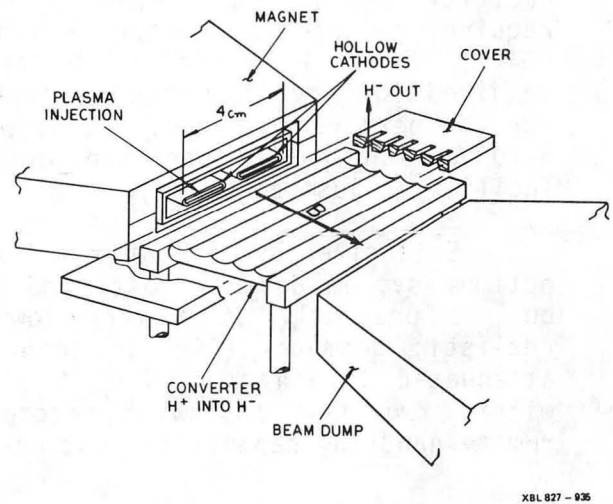

Fig. 15 Schematic diagram of BNL surface production negative ion source.

believe that the basic design of modules that could be adopted for possible reactor-experiment applications is nearly complete.

#### Negative-ion systems

This subject can be divided according to activity. The first is the development of dc negative ion sources with emphasis on beam quality, on increasing the available current/meter to at least twice the value available now, on increasing the gas efficiency, and on the elimination of cesium. Two operating surface-production sources are shown in Figures 14 and 15 [2].

The source shown in Fig. 14 [10] has operated steady-state with an output of 1.2A of H<sup>-</sup> ions. The development of the source shown in Fig. 15 [11] also is proceeding well. In both cases, control of the cesium used to lower the work function of the H<sup>-</sup> producing surface apparently is the key to success. Experiments currently in progress indicate that suitable volume-production sources, operating with pure H<sub>2</sub> or D<sub>2</sub>, will be developed in the next few years.

The second task is the demonstration of accelerator and beam transport technology capable of handling 5 to 10 A beams at 500 keV. TFF design is the primary approach, with the electrostatic quadrupole (ESQ) as the main backup concept. Extensive computations have been carried out, and experimental tests at the 160 kV, one-ampere level will start in 1985.

The third task is the development of a suitable neutralizer. The primary approach is a photoneutralizer employing the oxygen-iodine chemical laser. Other laser systems would be adopted if they appeared more suitable. The laser development effort is being carried out in industry, and a multikilowatt, long pulse, laser already has been demonstrated. About 100 kw, total, of laser power will be required. Suitable large test facilities are required for the negative-ion development program. The primary facility at this time is a 160 kV, 2A, long-pulse installation at LBL. The newest test facility is the LBL Neutral Beam Engineering Test Facility (NBETF), completed in April 1983. This has neutron shielding, required for operation with deuterium, and can operate with 120-kV, 40-A, or 80-kV, 65 A, 30-second pulses or a 10 duty cycle. This capability is required for development of positive-ion source modules of the MFTF-B type for the next year or two. It is planned to modify this facility for 200-kV, 5-10 A, long-pulse operation in about two years. Planning for a 500 kV facility is just beginning.

Extensive system studies are required to provide information on optimum system design, cost, and availability. This activity has started, but is presently at a very low level. One neutronic calculation on a realistic geometry (Fig. 9) showed that the incident neutron flux can be attenuated by a factor of 10<sup>6</sup>, allowing hands-on maintenance of the source within two days following reactor shutdown. However, it is clear that remote-handling capability must be included.

#### 4. Program

##### A. Positive-ion-based Systems

The first priority is the demonstration of useful 30-second source modules this year. Simultaneously, better and more reliable ways to generate the plasma in the ion sources will be pursued, for example, the development of r.f. generated plasma sources. Because there is no identified application after MFTF-B, and the development for MFTF-B will be completed within about two years, there is no long-range program for positive-ion-systems.

##### B. Negative-ion-based Systems

The schedule for development of neutral beam systems based on negative ions is set by the first application, tentatively the use of one-megawatt, 200 keV systems on an upgrade of MFTF-B at about the end of this decade. This may be followed by operation of 400- to 500- keV systems on a tandem mirror reactor in the next decade.

To develop these systems, the first step, presently being carried out, is a proof-of-principle experiment to demonstrate the production, transport, and acceleration (with strong-focussing TFF systems) of a 1-2 A H<sup>-</sup> beam to 160 keV under steady-state conditions and at full current density. Capability of extrapolation to a practical beamline is a requirement. This should be achieved in 1985. The next step is to operate this system with an efficient neutralizer. If a laser neutralizer is chosen, tests with a single module of a design capable of being extended to the full neutralizer will be satisfactory. This should be achieved in 1986. The first effort will demonstrate that a negative-ion-based neutral beam system can be built, although it may not be the most efficient design; the second will demonstrate that a highly efficient system can be built.

Simultaneously, planning, engineering, and construction of a facility for the development of steady state components and systems to operate with deuterium at the 500 keV level, and with a source module size of 5-10 A, will proceed. To insure system integration and to demonstrate reliability and maintainability, essential for application of neutral beam on a reactor-class experiment, it will be necessary to build and operate a true prototype neutral beam system.

#### 5. Remarks

During the next year or two, the basic testing of positive ion sources and systems for applications on the MFTF-B and other experiments of the 1980's will be completed. The systems and components will, of course, continue to evolve through use; by the end of this decade reliable, approximately steady-state, ion sources and injection systems will be available. The development of injectors suitable for application in the radiation environment of a reactor probably will not have taken place, but no application of this kind is in the U.S.A. plans at this time. It is likely that positive-ion-based neutral beam diagnostic systems will be used, but the requirements will be less stringent because they need not be exposed to the radiation continuously.

Applications of multimegawatt negative-ion-based systems in the 1990's are in the planning stage. These systems will be used in the end cells of tandem mirror devices for applications that require high reliability, neutral deuterium energies of 200-500 keV, precision beam optics, and protection from nuclear radiation. Proof-of-principle experiments should be finished within a few years.

Recent advances in ion source technology, new concepts in beam transport and acceleration systems, and the impending application of efficient laser photoneutralizers have enhanced the prospects of using negative-ion-based neutral beam systems on reactors. The application of these advances should lead to neutral injection systems that are both highly efficient (60-80%) and radiation-hardened. No technological concepts are lacking for the application of negative-ion-based neutral beams to reactors.

#### Acknowledgements

I wish to thank many individuals for their contributions and in particular, W. Cooper, K. Ehlers, J. Fink, C. Henning and L. Stewart.

#### References

1. B. G. Logan, "Mirror Advanced Reactor Studies", Proc. Fifth Topical Conference on Technology of Fusion Energy, Knoxville, April 1983.

2. K. W Ehlers, "Negative Ion Sources For Neutral Beam Systems", these proceedings, and Lawrence Berkeley Laboratory Report LBL-16222.
3. W. S. Cooper, "Summary of the Status of Negative-Ion Based Neutral Beams", Proc. Fifth Topical Conf. on Technology of Fusion Energy, Knoxville, April 1983.
4. R. J. Goldston, "Diagnostics for Hot Plasmas Using Hydrogen Neutral Beams", Princeton Plasma Physics Laboratory Report PPPL-1952 (1982).
5. P. Reardon, "Status Report on TFTR," Proc. 3rd Topical Meeting on the Technology of Nuclear Fusion, Santa Fe (1978) p. 621.
6. K. H Berkner, W. S. Cooper, K. W. Ehlers, V. L. Jacobson, H. M. Owren, J. A. Paterson and R. V. Pyle, "Long-Pulse Neutral Beam Injector Development at the Lawrence Berkeley Laboratory", Proc. 3rd Varenna-Grenoble International Symposium on Heating in Toroidal Plasmas, Grenoble, March, 1982.
7. M. M. Menor, "The Technology of Neutral Beam Injection Based on Positive Ion Sources", Proc. Fifth Topical Conf. on Technology of Fusion Energy, Knoxville, April 1983.
8. J. A Paterson, G. W. Koehler, and D. P. Yee, Proc. 9th Symp. on Engr. Prob. of Fusion Research, Chicago, IL (Oct. 1981) p. 233.
9. M. M. Menon, et al, "Development of an Ion Source for Long Pulse (30 s) Neutral Beam Injection", Proc. 12th Symp. on Fusion Technology (1982) p. 1375.
10. K. N. Leung and K. Ehlers, Rev. Sci, Instrum. 53, 803 (1982).
11. K. N. Leung, K. Ehlers, and M. Bacal, Rev. Sci. Instrum. 54, 56 (1983).



This report was done with support from the Department of Energy. Any conclusions or opinions expressed in this report represent solely those of the author(s) and not necessarily those of The Regents of the University of California, the Lawrence Berkeley Laboratory or the Department of Energy.

Reference to a company or product name does not imply approval or recommendation of the product by the University of California or the U.S. Department of Energy to the exclusion of others that may be suitable.

TECHNICAL INFORMATION DEPARTMENT  
LAWRENCE BERKELEY LABORATORY  
UNIVERSITY OF CALIFORNIA  
BERKELEY, CALIFORNIA 94720