

# UC Agriculture & Natural Resources

## Proceedings of the Vertebrate Pest Conference

### **Title**

Modified bait stations for California ground squirrel control in endangered kangaroo rat habitat

### **Permalink**

<https://escholarship.org/uc/item/37n7s995>

### **Journal**

Proceedings of the Vertebrate Pest Conference, 18(18)

### **ISSN**

0507-6773

### **Author**

Whisson, Desley A.

### **Publication Date**

1998

### **DOI**

10.5070/V418110221

# MODIFIED BAIT STATIONS FOR CALIFORNIA GROUND SQUIRREL CONTROL IN ENDANGERED KANGAROO RAT HABITAT

DESLEY A. WHISSON, Extension Wildlife Specialist, Department of Wildlife, Fish and Conservation Biology, University of California, One Shields Avenue, Davis, California 95616.

**ABSTRACT:** California ground squirrels are a major problem in areas that also support populations of endangered kangaroo rats. Traditional bait stations can be easily modified to exclude kangaroo rats, thereby providing landowners with a method of controlling ground squirrels that mitigates hazards to endangered kangaroo rats. Specifications for the design and use of modified bait stations are discussed.

**KEY WORDS:** California ground squirrel, *Spermophilus beecheyi*, elevated bait station, baiting, endangered kangaroo rats, endangered species

Proc. 18th Vertebr. Pest Conf. (R.O. Baker & A.C. Crabb, Eds.) Published at Univ. of Calif., Davis. 1998.

## INTRODUCTION

In central and southern California, ground squirrels (*Spermophilus beecheyi*) are a major problem in areas which also support populations of endangered kangaroo rats, namely the giant kangaroo rat (*Dipodomys ingens*), Fresno kangaroo rat (*D. nitratoides exilis*), Tipton's kangaroo rat (*D. nitratoides nitratoides*), and Stephens' kangaroo rat (*D. stephensi*). These kangaroo rat species now only comprise small, scattered populations, mostly occurring in close proximity to agricultural, grazing, or other developed lands (California Department of Fish and Game 1980; Williams and Kilburn 1992). The decline in these species and subspecies of kangaroo rats in California has been attributed to habitat fragmentation and loss through urbanization or agricultural development (California Department of Fish and Game 1980; O'Farrell and Uptain 1987; Kramer 1987, 1988; Williams and Kilburn 1992). Many kangaroo rat species now only comprise small, scattered populations, mostly occurring in close proximity to agricultural, grazing or otherwise developed lands. As a consequence, flooding, disease, loss of genetic diversity due to small population size and vertebrate pest control practices now threaten the continued existence of these populations. The risk of incidental poisoning of kangaroo rats with pesticides was addressed by the United States Fish and Wildlife Service (USFWS) in 1993 in a vertebrate pesticide Biological Opinion which proposed to severely limit rodenticide use on over 2.5 million acres of land to protect endangered species including the San Joaquin kit fox, blunt-nosed leopard lizard, and several species of kangaroo rats.

Control measures for California ground squirrels were severely impacted by these pesticide restrictions. Under the Biological Opinion, applications of zinc phosphide and anticoagulants (diphacinone and chlorophacinone) were prohibited within 100 yards of endangered kangaroo rat habitat. Use of fumigants (such as smoke cartridges) was permitted in the range of the species, but only by certified applicators trained to distinguish ground squirrel burrows from kangaroo rat burrows.

The Biological Opinion prompted a cooperative program involving Cal/EPA's Department of Pesticide Regulation, the California Department of Fish and Game, and the California Department of Food and Agriculture, to formulate mitigation strategies to allow control of

California ground squirrels and other pest species in endangered species habitat. These strategies have been endorsed by USEPA and USFWS and incorporated into County Bulletins which are enforced by county agricultural commissioners.

A study was funded by the Vertebrate Pest Control Research Advisory Committee (California bait surcharge program) to: 1) conduct a literature review on the ecology and behavior of kangaroo rats in California ground squirrel habitat to determine impacts of rodenticides and fumigants on kangaroo rats and identify techniques to mitigate hazards; and 2) determine if bait stations could be modified to prevent access by kangaroo rats while still allowing ground squirrels to feed on bait.

## LABORATORY AND FIELD TESTS OF MODIFIED BAIT STATIONS

Reports of kangaroo rats climbing or jumping are limited to a few anecdotal accounts (Bartholomew and Caswell 1951; Eisenberg 1963; Kenagy 1972; Lemens and Freeman 1985, 1986; Williams 1992). Elevating the entrances to bait stations was, therefore, considered as a way to exclude kangaroo rats, while allowing access by California ground squirrels which are good climbers (Marsh 1994a). A number of designs for elevated bait stations have been proposed (R. Baker, pers. comm.), but the effectiveness of these stations in excluding kangaroo rats has not been well documented. Simple, low cost methods of modifying box and inverted "T" bait stations were considered.

Laboratory tests conducted at the University of California, Davis, determined that kangaroo rats can climb or jump to reach food when they are presented with a solid surface or means of climbing. Twenty Heermann's kangaroo rats, a species that is not endangered, were exposed to bait stations elevated in a variety of ways. All rats were able to jump to bait boxes elevated up to 60 cm (24 inches) high on concrete blocks. Even a 5 cm (2 inch) overhang added to the top of the concrete blocks failed to restrict access by kangaroo rats. Kangaroo rats also were able to climb to the bait stations when the platform was placed against a chicken wire fence, and when ramps to help ground squirrels climb to the bait boxes were added. However, bait boxes placed on table platforms with legs inset 5 cm (2 inches) proved

to be inaccessible to kangaroo rats (Figure 1a). Similarly, kangaroo rats did not use inverted "T" bait stations that were modified by adding angled sections of pipe to elevate the entrances to 30 cm (12 inches) (Figure 1b). Results suggest that the potential for kangaroo rats to learn how to access these bait stations is low. These designs were the last to be tested in the laboratory so were tested with kangaroo rats that had already learned to jump or climb to box bait stations placed on concrete blocks.

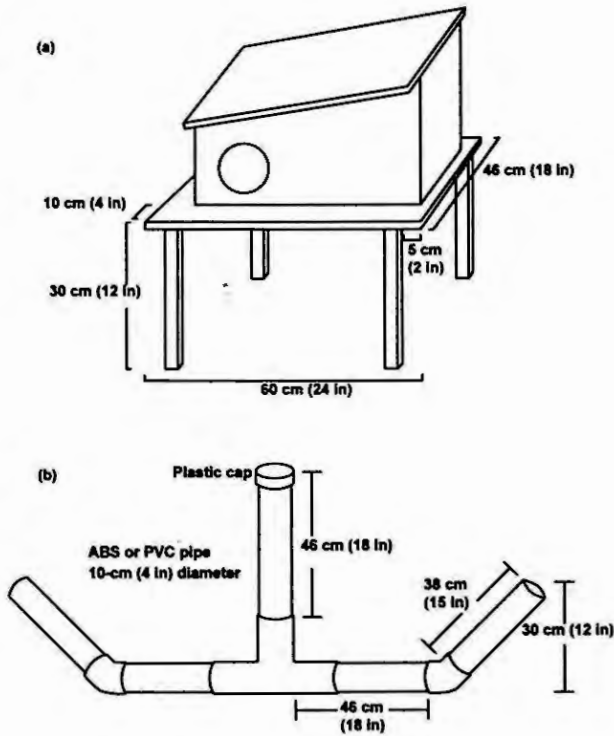

Figure 1. (a) Box bait station elevated on a table platform; (b) modified inverted "T" bait station.

The bait stations that excluded kangaroo rats in the laboratory tests were then tested for accessibility by giant kangaroo rats on the Elkhorn Plains, San Luis Obispo County in June and August 1996, and by Stephen's kangaroo rats on Lake Mathews Reserve, Riverside County in August 1996. Remote cameras were used to monitor visitors to the bait stations. Despite large populations of kangaroo rats in both areas, kangaroo rats did not visit modified bait stations. On the Elkhorn Plains, the only visitors to the modified bait stations were San Joaquin antelope squirrels during the day, and night visits by San Joaquin kit fox and rabbits. On Lake Mathews Reserve, bait stations were visited by rabbits.

Accessibility of the modified bait stations by California ground squirrels was tested on the University of California, Davis campus. Except for one inverted "T" bait station, California ground squirrels began visiting the modified bait stations within a week of their placement. The angled sections were removed from the bait station that had not been visited after two weeks.

Once squirrels began visiting the unmodified station (within four days), the angled sections were replaced and squirrels continued to feed from the station.

#### BAIT STATION SPECIFICATIONS

Elevating box bait stations to  $\geq 30$  cm (12 inches) on table platforms or elevating the entrances to inverted "T" bait stations to  $\geq 30$  cm (12 inches) will reduce the risk of endangered kangaroo rats feeding on poison bait but still allow California ground squirrels to access bait. However, care must be taken to adhere to the following specifications:

1. Bait boxes should not be placed on a solid base. Kangaroo rats are able to jump or climb to heights of up to 60 cm (24 inches) if they are presented with a solid base. Even a platform top with a 3 inch (7.5 cm) overhang over a solid base is easily negotiated by kangaroo rats.
2. The legs of the platform should be inset at least 5 cm (2 inches) to stop kangaroo rats from climbing into the station. Ramps or wire mesh should not be added to improve accessibility by ground squirrels as kangaroo rats will learn to use these to climb into the bait station.
3. Other modifications to box bait stations may be necessary to prevent ground squirrels from spilling poison bait on the ground. The modified inverted "T" bait station has the advantage that bait is rarely spilled on the ground.
4. In rangeland where livestock are present, bait stations should be firmly secured to the ground to prevent them from being tipped over.
5. It is important to ensure that the vegetation is cleared from around the entrances. Kangaroo rats will be able to climb into the stations if dense vegetation is present or if the stations are placed against a  $\leq 1.25$  cm ( $\frac{1}{2}$  inch) wire mesh fence. Keep entrances away from fence posts and large rocks that might be used by kangaroo rats to gain access.
6. Rain or use of sprinkler irrigators may result in water collecting in the bait stations causing bait to become moldy and less palatable to squirrels. In locations where this is likely, it may be necessary to further modify the bait station by adding an additional horizontal extension, or drilling a small hole in the bottom of the station to drain water, and to check bait stations more frequently to replace wet bait.
7. In kit fox range, the entrance to the station should be no greater than 7.5 cm (3 inches) in diameter. This can be achieved by fitting a 10 cm (4 inch) to 7.5 cm (3 inch) reducer or one-half an endcap.
8. In some instances, ground squirrels may take longer to discover the bait placed in modified bait stations. However, this problem may be solved by first placing an unmodified station containing clean grain. Once the squirrels begin feeding from the station, the station may be modified, poison bait added and the squirrels will continue to visit the station.

#### OTHER CONSIDERATIONS

Although kangaroo rats are excluded from poison bait placed in elevated bait stations, they still may be at risk of poisoning from bait cached by California ground

squirrels. Because ground squirrels cache seed more frequently in late summer and fall (Marsh 1994b), limiting bait applications (in elevated bait stations) to late spring and early summer may reduce hazards to kangaroo rats. Moving modified bait stations from the perimeters of crops to a short distance inside the crop may further reduce the risk of incidental poisoning of kangaroo rats. Although ground squirrels establish colonies on the perimeters of crops, they will generally range and feed in the adjacent crop (Marsh 1994a,b). Conversely, most endangered kangaroo rat species have smaller home ranges (Eisenberg 1963; Price et al. 1994) and may be restricted to land that is not under regular cultivation (Best 1991; Williams 1992).

Although the presence of kangaroo rats complicates ground squirrel control, the ecology and behavior differences between the species make it possible to mitigate potential hazards to the endangered species. Differences in burrow size, and other burrow related characteristics of kangaroo rats and ground squirrels, enable fumigants to be selectively directed to only the targeted ground squirrels. The use of elevated bait stations and careful timing of baiting operations will minimize hazards.

#### ACKNOWLEDGMENTS

This study was funded by the California Vertebrate Pest Control Research Advisory Committee. R. Marsh and R. Baker provided helpful advice on bait station design. R. Hosea assisted with the field work. The author thanks the Metropolitan Water District of Southern California, and the Endangered Species Recovery Planning Unit for use of their facilities.

#### LITERATURE CITED

- BARTHOLOMEW, G. A., and H. H. CASWELL. 1951. Locomotion in kangaroo rats and its adaptive significance. *Journal of Mammalogy* 32:155-169.
- BEST, T. L. 1991. *Dipodomys nitratoides*. *Mammalian Species*. 381:1-7.
- CALIFORNIA DEPARTMENT OF FISH AND GAME. 1980. At the Crossroads: a report on the status of California's endangered and rare fish and wildlife. California Department of Fish and Game, Sacramento 147 pp.
- EISENBERG, J. F. 1963. The behavior of Heteromyid rodents. University of California Publications 1-78.
- KENAGY, G. J. 1972. Saltbush leaves: excision of hypersaline tissue by a kangaroo rat. *Science* 178:1094-1096.

- KRAMER, K. 1987. Endangered and threatened wildlife and plants: Determination of endangered status for Stephens' kangaroo rat. *Federal Register*, 52:44453- 44454.
- KRAMER, K. 1988. Endangered and threatened wildlife and plants: determination of endangered status for Stephens' kangaroo rat. Final Rule. *Federal Register*, 53:38465-38469.
- LEMEN, C., and P. W. FREEMAN. 1985. Tracking animals with fluorescent pigments: a new technique. *Journal of Mammalogy* 66:134-136.
- LEMEN, C., and P. W. FREEMAN. 1986. Habitat selection and movement patterns in sandhill rodents. *Prairie Naturalist* 18:129-141.
- MARSH, R. E. 1994a. Belding's, California, and rock ground squirrels. Pages B151-B158 in S. E. Hynstrom, R. M. Timm and G. E. Larson, eds. University of Nebraska Cooperative Extension, U.S. Department of Agriculture-Animal and Plant Health Inspection Service-Animal Damage Control, and Great Plains Agricultural Council-Wildlife Committee.
- MARSH, R. E. 1994b. Current (1994) ground squirrel control practices in California. *Proc. 16th Vertebr. Pest Conf.* (W. S. Halverson and A. C. Crabb, eds.). University of California, Davis. 16:61-65.
- O'FARRELL, M. J., and C. E. UPTAIN. 1987. Distribution and aspects of the natural history of Stephens' kangaroo rat (*Dipodomys stephensi*) on the Warner ranch, San Diego Co., CA. *Wasmann Journal of Biology* 45(1-2):34-48.
- PRICE, M. V., P. A. KELLY, and R. L. GOLDINGAY. 1994. Distances moved by Stephens' kangaroo rat (*Dipodomys stephensi merriam*) and implications for conservation. *Journal of Mammalogy* 75:929-939.
- WILLIAMS, D. F. 1992. Geographic distribution and population status of the giant kangaroo rat. Pages 301-328 in D. F. Williams, S. Byrne, and T. A. Rado, eds. *Endangered and Sensitive Species of the San Joaquin Valley, California*. California Energy Commission, Sacramento.
- WILLIAMS, D. F., and K. S. KILBURN. 1992. The conservation status of the endemic mammals of the San Joaquin faunal region, California. Pages 329-345 in D. F. Williams, S. Byrne, and T. A. Rado, eds. *Endangered and Sensitive Species of the San Joaquin Valley, California*. California Energy Commission, Sacramento. 388 pp.