

Lawrence Berkeley National Laboratory

LBL Publications

Title

Study and Use of Rotating Plasma

Permalink

<https://escholarship.org/uc/item/37z100f2>

Authors

Anderson, C A

Baker, W R

Bratenahl, A

et al.

Publication Date

2024-03-06

UNIVERSITY OF
CALIFORNIA

Ernest O. Lawrence

*Radiation
Laboratory*

TWO-WEEK LOAN COPY

*This is a Library Circulating Copy
which may be borrowed for two weeks.
For a personal retention copy, call
Tech. Info. Division, Ext. 5545*

BERKELEY, CALIFORNIA

DISCLAIMER

This document was prepared as an account of work sponsored by the United States Government. While this document is believed to contain correct information, neither the United States Government nor any agency thereof, nor the Regents of the University of California, nor any of their employees, makes any warranty, express or implied, or assumes any legal responsibility for the accuracy, completeness, or usefulness of any information, apparatus, product, or process disclosed, or represents that its use would not infringe privately owned rights. Reference herein to any specific commercial product, process, or service by its trade name, trademark, manufacturer, or otherwise, does not necessarily constitute or imply its endorsement, recommendation, or favoring by the United States Government or any agency thereof, or the Regents of the University of California. The views and opinions of authors expressed herein do not necessarily state or reflect those of the United States Government or any agency thereof or the Regents of the University of California.

STUDY AND USE OF ROTATING PLASMA

O. A. Anderson,* W. R. Baker,* A. Bratenahl,* H. P. Furth,†
J. Ise, Jr.,* W. B. Kunkel,* and J. M. Stone*

INTRODUCTION

This paper is intended as a preliminary report on the Homopolar device (axial magnetic field with radial electric field), which is the rotating plasma configuration most thoroughly investigated thus far. A study of this configuration for aerodynamic purposes was reported in 1950 by H. C. Early et al.,¹ and a more complete report was issued in 1952.² Some ion sources having the same basic geometry were reported in 1955 by J. Luce and L. P. Smith.³ The hydro-magnetic Homopolar machine was conceived by William R. Baker and Oscar A. Anderson in 1956, as a device for the containment and heating of a thermonuclear plasma. More recently, there have been significant contributions to this technique by Gow and Wilcox,⁴ and by Boyer, Hammel, Longmire, Nagel, Ribe, and Riesenfeld.⁵

The analysis presented in this paper applies principally to the "ideal" Homopolar, that is, the configuration free from electrode-sheath drops and other disturbing but remediable phenomena. The experiments described here have been carried out mostly under high-density (pinch-type) conditions which favor the creation of a totally rotating plasma. As models of the Homopolar grow larger, it will become possible to use the present pinch-type technique of plasma formation at much lower density, just as in the case of the large toroidal stabilized pinch.⁶

The Rotational Equilibrium State

Whenever currents flow in plasmas across magnetic field lines, as for example in most pinch-type configurations, the resultant Lorentz force must be balanced by static or inertial plasma pressures. Where such pressure is lacking (e. g., in the low- β stabilized pinch), the current flows along field lines or ceases to flow. In the Homopolar, Fig. 1, a transient radial current is drawn while the plasma is accelerated to its equilibrium rotation. In equilibrium, the driving electric field vanishes in the plasma rest frame, and the radial current ceases. The equilibrium velocity of rotation is

*Radiation Laboratory, University of California, Berkeley, California.

†Radiation Laboratory, University of California, Livermore, California.

$$v_{\theta} = \frac{1}{H} \left(Ec + \frac{mv_{\theta}^2}{er} \right). \quad (1)$$

The second term, a centrifugal effect, depends on e/m and, although small, results in different drift velocities for electrons and ions. As a result, an azimuthal current flows and the associated Lorenz force just balances the centrifugal pressure of the plasma. If the plasma conductivity is finite, there is also an azimuthal electric field resulting in a slow outward drift of plasma--a diffusive process impelled, so to speak, by centrifugal pressure.

A sudden application of electric field to the Homopolar would produce trochoidal ion orbits as in Fig. 2b. In practice, the applied voltage drops sharply at the instant of ionization and then builds up again as the plasma rotation develops. The effective electric field in the plasma in general rises slowly compared with an ion Larmor period. The ion orbits therefore are likely to be of the form shown in Fig. 2a. Although the direction of drift is the same for particles of either sign, the mean radial displacements of ions and electrons are in opposite directions. The effect is similar to the displacement phenomenon in a dielectric. The associated dielectric constant may be evaluated by ascribing the drift-energy density of the plasma to the electric-field-energy density. Neglecting the second term of Eq. (1), we have

$$\frac{KE^2}{8\pi} = \frac{E^2}{8\pi} + \frac{1}{2} \rho v_{\theta}^2 = \frac{E^2}{8\pi} \left(1 + \frac{4\pi \rho c^2}{H^2} \right), \quad (2)$$

$$K = 1 + \frac{4\pi \rho c^2}{H^2}, \quad (3)$$

where ρ is the mass density of the plasma.

If the plasma in a rotational device may be regarded as a dielectric, then the machine itself must resemble a capacitor. The Homopolar experiment is essentially equivalent to connecting an uncharged capacitor, the Homopolar, to a charged capacitor, the source condenser bank, through an intermediate resistance and inductance (Fig. 3). In general there results a damped oscillation with the current and voltage approximately 90° out of phase, and equilibrium is reached with the charge so distributed that the voltages on the two capacitors are equal (Fig. 4). The current ceases at equilibrium except for a trickle through the leakage resistance, R_L , representing viscous drag and heating.

The kinetic energy of the rotating plasma is the analogue of stored energy in a capacitor $1/2 CV^2$. Another constant of the motion, the angular momentum P_{θ} , is the analogue of the charge, $Q = CV$. The torque impulse due to the current through the Homopolar must in the ideal case equal the angular momentum imparted to the plasma disc. It is easily shown that, neglecting losses, we have

$$P_{\theta} = \int H r dr \int I dt = \frac{1}{2\pi} \phi Q, \quad (4)$$

where ϕ is total magnetic flux.

The capacitor analogy may be carried to its logical extreme with the addition of a "crowbar" shorting switch to the circuit of Fig. 3.

If the crowbar switch is closed at a time when there is voltage across the Homopolar, there must result a surge current through the Homopolar and crowbar (Fig. 5). There can be little doubt that the charge represented by the outpouring of the current gives a measure of the angular momentum stored in the rotating plasma, since the crowbar current is opposite in direction to the charging current. The voltage and current oscillations after crowbarring represent hydromagnetic oscillations of the plasma similar to the motion of a torsion pendulum.

Plasma Containment by Centrifugal Force

In an ordinary mirror machine, only those ions are contained that have a sufficiently large ratio of azimuthal to axial velocity. Other ions are lost through an "escape cone" in velocity space. Particles are continually diffusing into this cone by collisions. At higher temperatures, diffusion--and hence loss rate--decreases while thermonuclear yield increases on account of the behavior of the appropriate cross sections. Much higher operating temperatures are therefore required in a practical machine in order to control the loss rate. The escape cone is a serious inconvenience.

If one applies a radial electric field to a mirror machine, there are at first components of E parallel to H , but since in general we have

$$E^2/8\pi \ll nKT, \quad (5)$$

the plasma will readjust itself so that E becomes orthogonal to H . Once this has happened, it turns out that all first-order effects in E , tending either to contain or to expel particles, cancel out. The second-order effect in E permits containment of all particles up to a certain kinetic energy. In other words, for sufficiently large E the escape cone can be truncated arbitrarily far out in velocity space.

This proposition is seen to be plausible when one notes that the azimuthal drift in the electric field produces a centrifugal force tending to keep particles from approaching the axis of drift. Since passage through the mirror involves approach to the machine axis, there is thus an effective mirror repulsion which is independent of particle sign and, like the centrifugal force, increases with the square of E .

The idea of plasma containment in a mirror machine by means of the "gravitational" effect was first proposed by Baker and Anderson in 1956. A rigorous mathematical analysis was recently undertaken by Nagle, Ribe, and Boyer leading to the elegant theory of Longmire.⁵ An elementary derivation giving the same results in the limit of weak mirror ratio R_m was made by H. P. Furth. It is found² that the maximum axial kinetic energy that can be contained is

$$W_{||} = W_{\perp} (R_m - 1) + \frac{1}{2} m v_{\theta}^2 \left(\frac{R_m - 1}{R_m} \right). \quad (6)$$

in which W_{\parallel} and W_{\perp} are the energies of thermal motion parallel and perpendicular respectively to H . Note that the enhanced containment (second term of Eq. (6)) depends on the magnitude of the rotational kinetic energy of a particle, and also on R_m . Unfortunately very large values of R_m appear to be of little use in achieving a high degree of enhanced containment. It should be said, however, that the analysis leading to Eq. (6) is valid only in the limit where the mirror field varies slowly over the particle trajectory (adiabatic limit).

It should also be noted that the containment effect is much smaller for electrons than for ions, given a common velocity of rotation $v\theta$, but the consequences need not be serious. The loss of electrons through the escape cone sets up an axial electrostatic potential equal to the mean energy of escaping electrons. This potential will be weak if the electron temperature is kept well below the ion temperature, as it should be in a practical machine. A very serious practical consideration is that, if the rotational kinetic energy of the ions is merely made equal to the mean ion thermal energy, then the more energetic ions escape at about the same rate as from an ordinary mirror machine. It is necessary therefore to set the rotational energy equal to the energy of the most energetic ions one desires to have participate significantly in the fusion process. For example, for $R_m \sim 2$, $E = 4$ kv/cm, $H = 4$ kgauss, and ion density a few times 10^{15} , one would have containment up to 10 kev. This is satisfactory for an experimental thermonuclear plasma device but not for an economical power-producing machine. For much higher energies, the over-all voltages required in large machines may present difficulties.

Plasma Heating

If a thermonuclear kinetic energy density can be imparted to a rotating plasma, one may hope in a general way that some of this will be converted into disordered motion. Since the Homopolar, unlike the ordinary mirror machine, has no simple "escape cone" in velocity space, there is no objection in principle to particle collisions. Various diffusive processes of thermalization are therefore conceivable. The situation is similar to that in the stabilized pinch. In both cases a long-lived equilibrium state can readily be created, and one looks next for processes that will convert stored nonthermal energy density into thermal energy density at a suitable rate.

The plasma of the Homopolar, like the plasma of the stabilized pinch, is heated in the process of outward diffusion. This is just the ordinary Joule heating process. Since the velocity distribution in the rotating plasma tends to go as $1/r$, there is also viscous drag between plasma layers. The associated heating effect is comparable to Joule heating. Probably there can also be some turbulent mixing of plasma layers, resulting in additional thermalization.

While the charging current of the Homopolar is drawn, there results a pinch-type compression in the axial direction. It can be shown that this effect is always sufficient to produce a moderate pinch away from the wall, but insufficient to compress the plasma appreciably, provided the energy density of the plasma rotation is comparable to that of the axial magnetic field.

Aside from these built-in heating mechanisms, there are also various artificial means one can employ. For example, superimposing a rapidly oscillating component on the radial electric field can set up a standing hydromagnetic half-wave in the axial direction. The wave propagation velocity is the Alfvén speed,

$$v_s = c/\sqrt{K}. \quad (7)$$

and amounts to only 3×10^7 cm/sec for a typical dielectric constant of $K = 10^6$. The viscous drag brought into play by the associated velocity gradients along field lines is large and should result in a rapid conversion of directed kinetic energy into heat energy. Experience with deuterium pinch devices has shown that $n_0 r_0^2 \approx 2 \times 10^{16}$ cm $^{-1}$ for optimum performance, where r_0 is the tube radius and n_0 the initial particle density. It is an interesting coincidence that an Alfvén half-wave length $\lambda/2$ at the deuteron cyclotron frequency is just such as to give $n\lambda^2/4 = 2 \times 10^{16}$ cm $^{-1}$.

As an alternative to impressing an oscillatory electric field, one can simply perturb the cylindrical symmetry of the Homopolar. Once a certain level of thermal and rotational energy has been established it can also be enhanced by radial compression as in a mirror machine.

Experimental Results on Homopolar I

Homopolar I is illustrated in Fig. 1. The discharge space is bounded by a central electrode 3 in. in diameter, an outer electrode 9-3/4 in. in diameter, and a pair of Vicor glass plates 5/8 in. apart that lie against the pole faces of an electromagnet. The glass serves to separate the plasma discharge current from the return current that flows over the copper-plated pole faces. The discharge current is supplied by a condenser bank, usually 48 μ f. This source is connected to the outer electrode through 48 coaxial cables like the one shown in the figure. Deuterium, helium, neon, argon, and iodine vapor have been employed in these hydromagnetic experiments.

At the time of breakdown, the plasma is pinched away from the glass. The radial pinch current, typically of the order of 50 ka, produces a torque as it flows across the axial magnetic field, and the torque accelerates the plasma into the rotational state. The pinch phase is accompanied by a rapid fall of the applied voltage, which subsequently rises again during the acceleration phase. The high voltage then decays slowly during the rotation state because of losses and internal heating. The current shows a rise during the pinch and early acceleration phase, but then falls again to a very low value as the equilibrium rotation state is reached.

Under certain circumstances the voltage and current have an oscillatory character but in most of the experiments the discharge is approximately critically damped. The phase of the voltage and current are always such as to demonstrate the capacitorlike behavior of the Homopolar. Accordingly, the Homopolar is represented in Fig. 3 as the capacitor C_H , and the loss mechanism (which includes internal heating) by the shunt resistance R_L .

Typical oscillatory behavior is shown in Fig. 4. The upper pair of traces, with magnetic field switched off, show voltage and current in phase. In this case C_H in Fig. 3 should be replaced by short circuit and the period of oscillation is $T_s = 2\pi\sqrt{(L_s + L_H)C_s}$. The lower traces with 13 kgauss magnetic field show the $\sim 90^\circ$ phase shift between voltage and current. As the gas pressure is reduced the period, which is given by

$$T_{sH} = 2\pi \sqrt{(L_s + L_H) C_H C_s / (C_H + C_s)}, \quad (8)$$

is also reduced, in quantitative agreement with the reduction of the dielectric constant K , Eq. (3), of C_H . It will further be noticed that the equilibrium voltage, which is proportional to $C_s / (C_s + C_H)$, increases with decreasing gas pressure, again in complete agreement with Eq. (3).

In order to demonstrate that the Homopolar is in fact a device that stores energy as a condenser does, it is useful to apply the low-inductance short circuit or "crowbar" already mentioned. Figs. 5a and 5b show, in an overlay of a number of traces, the general behavior of the crowbar signal as a function of time after charging. The period of the oscillation is

$$T = 2\pi \sqrt{(L_H + L_C) C_H}.$$

It is quite clear that the Homopolar presents interesting possibilities as a practical capacitor. Rates of change of current of $\sim 5 \times 10^{11}$ amperes/sec, up to peak currents of 300 kiloamperes, are readily obtainable in Homopolar I. The low inductance, $< 0.001 \mu\text{h}$, and high dielectric constant, $> 10^6$, result in a very compact system of electrical energy storage. Further considerations of the plasma Homopolar as a hydromagnetic capacitor will be published elsewhere.

Besides showing the comparatively long lifetime of the rotational state, the crowbar has provided a useful diagnostic technique to determine the dielectric constant under variations of pressure and magnetic field. Since the vacuum capacity of the Homopolar is $0.75 \mu\text{f}$, K is given by

$$C = 0.75 \times 10^{-12} K = \frac{1}{V} \int I dt = \frac{Q}{V}, \quad (9)$$

where V is voltage at time of crowbar and the integral is taken over the first quarter cycle of the crowbar current. It was possible to vary K between the limits of 10^6 to 10^8 , and over this variation the ratio of the observed dielectric constant to that calculated from Eq. (3) falls in the limits

$$1 < K_{\text{obs}}/K_{\text{th}} < 2. \quad (10)$$

Both the nature of the observed limits on the variation of $K_{\text{obs}}/K_{\text{th}}$ and the behavior of C_H with time provide diagnostic information. The lower limit of the variation is taken to mean that essentially all the initial gas has become a rotating plasma. The upper limit can be understood in a qualitative way by comparison with an idealized case. It has already been mentioned that when the centrifugal plasma pressure becomes comparable with the magnetic field energy density, the plasma leans heavily on the magnetic field lines, bending them outward, increasing the mirror ratio. In the idealized case the conductivity is taken to be infinite so that in the absence of diffusion across magnetic field lines, plasma and field distort together. It is easy to show that the capacity is modified as follows:

$$C_H = C_{HO} \frac{2 \ln \frac{r_2}{r_1}}{r_2^2 - r_1^2} \frac{\int_{r_1}^{r_2} \psi r dr}{\int_{r_1}^{r_2} \psi \frac{dr}{r}} \quad (11)$$

where $H = \psi H_0$ is the distended magnetic field, r_1 , r_2 are the inner and outer radii of the Homopolar, and C_{HO} is the unmodified capacity. If all the magnetic field were crowded against the outer electrode, then $C_H = 2.45 C_{HO}$. This upper limit is compatible with the experimental values of K_{obs}/K_{th} . If the finite plasma conductivity is taken into account, then the calculation becomes much more complicated. One obvious conclusion is that when plasma is actually lost by resistive diffusion out of the system, then C_H will be diminished. A reduction in C_H after long times has been observed under conditions of large E/H , although under most conditions C_H remains essentially constant during the lifetime of the rotational state. Above 10 kv, Homopolar I appears to break down across the glass insulators.

Figure 6 shows an analysis of the data of Fig. 5a. Curve A gives the charge Q of Eq. (4) at the various crowbar times. Curve D is the true charging current obtained from A by differentiating the curve. It is seen to be less than the observed input current, Curve B, and starts somewhat later. Evidently excess current flows through the device without increasing angular momentum of the plasma, and thus represents current flowing in R_L of Fig. 3. This current is associated with viscosity of the initially cold gas and with viscous drag on the walls. From Eq. (1) one obtains $\bar{v}_\theta \sim 3 \times 10^6$ cm/sec, with a maximum of 6×10^6 cm/sec. The corresponding argon energies are 180 ev and 660 ev. $C_H = 5.7 \mu\text{f}$ remained constant for the time of observation in this case $K_{obs}/K_{th} = 1.0$.

A distinction should be made between long-lived rotational effects and actual containment. The containment of the plasma in the rotating state depends on the notion of trapping by centrifugal force in a trough of magnetic field, but actual containment must depend on whether the plasma is in fact leaning on the field, or whether it is leaning on the walls. Evidence that the plasma is indeed leaning on the field is shown in a typical magnetic probe or spin loop signal, the third trace of Fig. 7. This signal was obtained by a probe coil located between the glass plate and the pole piece.

The coil is oriented to detect the enhancement of the radial component H_r produced by the rotating plasma. The second term in Eq. (1) for the velocity v_θ results in an azimuthal current density

$$j_\theta = \frac{1}{H} \frac{\rho v_\theta^2}{r} \sim \frac{E^2}{H^3} \quad (12)$$

This current is the source of H_r , the centrifugally produced distortion of the magnetic field. As proof that the component H_r is produced in the manner stated, it is observed that H_r changes sign with reversal of H but not with

reversal of E. It is gratifying to see that H_{α} has the same general lifetime as the rotating state. One concludes that the plasma is leaning on the field lines for the duration of the rotating state.

For final proof that the plasma is in a rotating state, the Doppler shift of spectral lines may be observed. Provision was made for spectrographic observations along a line of sight passing within 1/2 in. of the inner surface of the outer electrode. By photographing the Homopolar spectrum with the magnetic field first in one direction, then in the other, one can observe shifts in the lines due to the Doppler effect. The shifts are symmetrical about reference lines with no field. Figure 8 shows shift of 3888 Å He and some impurity lines under the conditions 8 kv, 17 kgauss, 600 microns He gas for normal and reversed direction of the magnetic field. The lower comparison spectrum is for He and Hg. The shift corresponds to a velocity of $\sim 3 \times 10^6$ cm/sec. It is expected that higher velocities would be found near the central electrode.

ACKNOWLEDGMENTS

We thank Chester M. Van Atta for stimulating encouragement and Stirling A. Colgate and Herbert F. York for helpful discussions. We are indebted to Allen N. Kaufman, Lloyd Smith, Kenneth Watson, and Ted Northrop for theoretical support; to John Wier for the designs and Elliot B. Hewitt for early experimental work, and to technicians under Arthur Hartwig and Louis Biagi.

REFERENCES

1. Early, H. C., and Dow, W. D., Supersonic Wind at Low Pressure Produced by Arc in Magnetic Field, Phys. Rev. 79:186 (1950).
2. Early, H. C., Smith, H. L., and Lu, D. C., Electric Wind Phenomena, Summary Report No. 1, Engineering Research Institute, University of Michigan, Nov. 1952.
3. Smith, L. P., and Luce, J., Conferences on Thermonuclear Reactions at Princeton, N. J., June 1954 and UCRL Livermore, California, Feb. 1955.
4. Gow, J. D., and Wilcox, J. M., Conference on Thermonuclear Reactions, Washington, D. C., Feb. 1958.
5. Boyer, K., Hammel, J. E., Longmire, C. L., Nagel, D. C., Ribe, F. L., and Riesenfeld, W. B., Experimental and Theoretical Discussion of Ixion, a Thermonuclear Device, International Conference on Peaceful Uses of Atomic Energy, Sept. 1958.
6. Thonemann, P. C., Carruthers, R., Fry, D. W., Pease, R. S., Harding, G. N., Ramsden, S. A. Butt, E. P., McWhirter, E., Lees, D. J., Dellis, A., Ward, S., and Gibson, A., The Production of High Temperatures and Nuclear Reactions in a Gas Discharge, AERE, Harwell, Nature 181:217 (1958).
7. Anderson, O. A., Baker, W. R., Bratenahl, A., Furth, H. P., Kunkel, W. B., and Stone, J. M., The Hydromagnetic Capacitor, to be submitted to the Journal of Applied Physics.

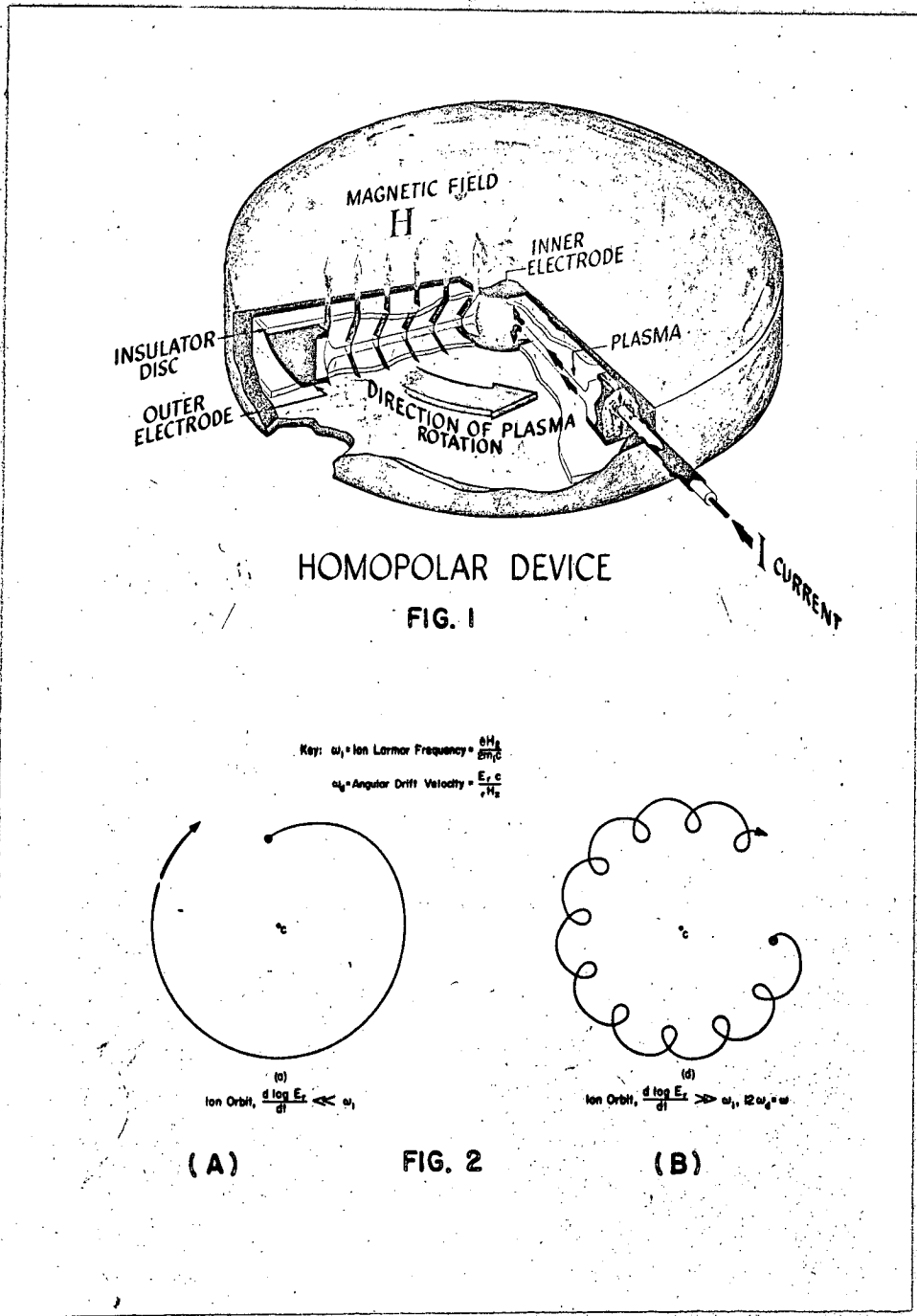

Fig. 1. Homopolar I.

Fig. 2. Particle trajectories in the Homopolar.

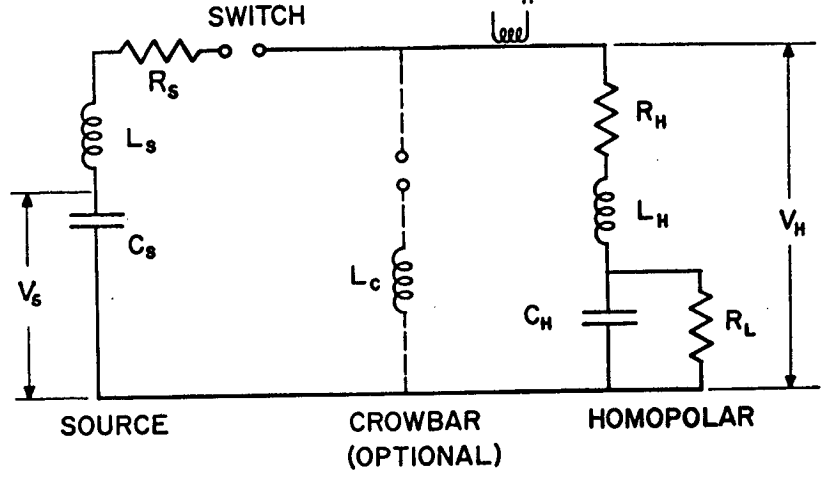

FIG. 3

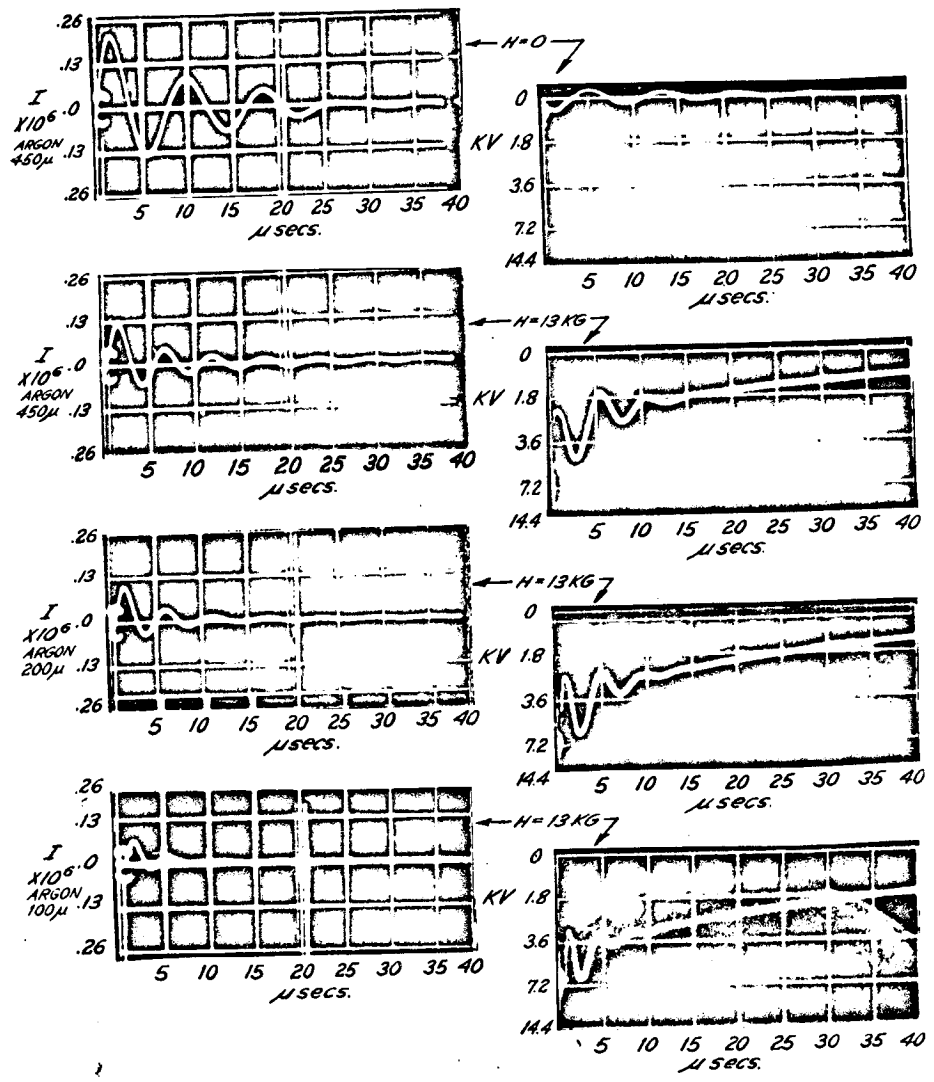
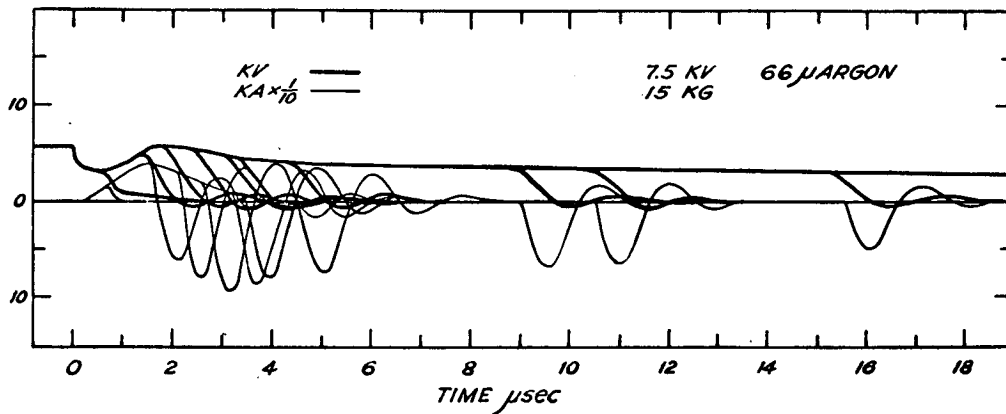

FIG. 4

Fig. 3. Equivalent circuit of the Homopolar experiment.

Fig. 4. Current and voltage response in Homopolar I. Upper traces, no magnetic field; lower traces show effect of decreasing pressure.



(A)

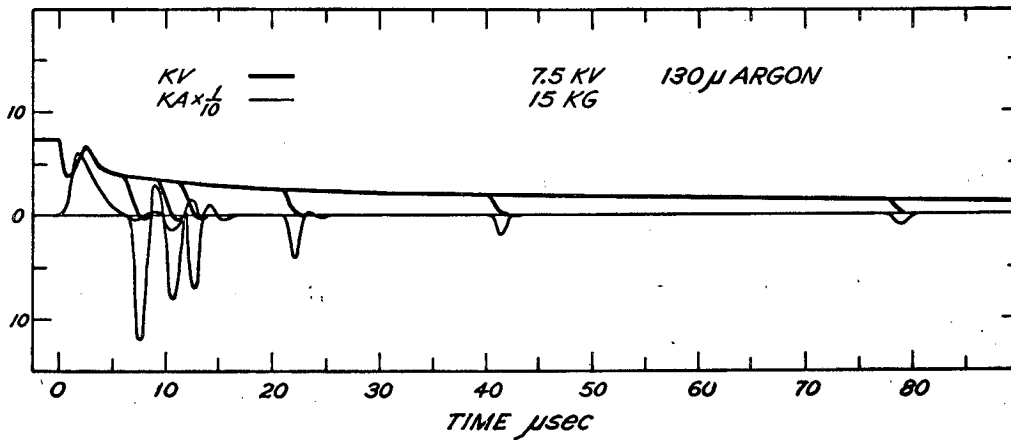

FIG. 5

(B)

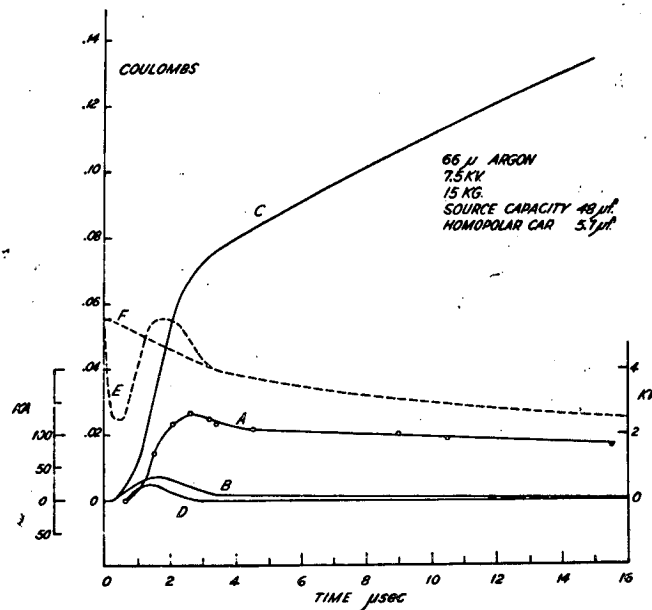

FIG. 6

Fig. 5. Superposition of a number of crowbar signals.

Fig. 6. Analysis of data of Fig. 5a.

~~SECRET~~

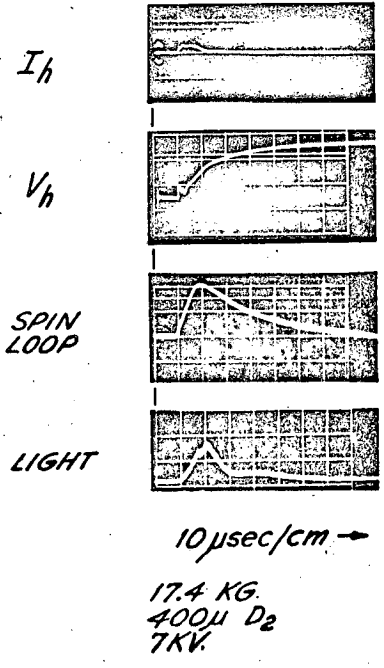

FIG. 7

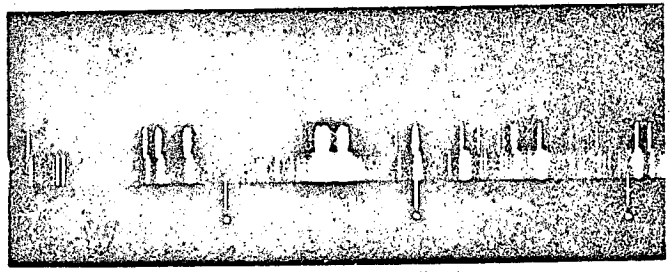

FIG. 8

Fig. 7. Spin loop signal with deuterium; also shown is visible light output.

Fig. 8. Doppler shift of 3888 Å He and some impurity lines. The spectra are for normal and reversed magnetic fields. The comparison spectrum is He and Hg.

~~SECRET~~