

# Lawrence Berkeley National Laboratory

## LBL Dissertations

### **Title**

THE NATURE AND FORMATION OF NITROGENOUS AIR POLLUTANT EMISSIONS FROM COMBUSTION SYSTEMS

### **Permalink**

<https://escholarship.org/uc/item/3811f9m2>

### **Author**

Matthews, Ronald Douglas.

### **Publication Date**

1977-10-01

Thesis/dissertation

0 0 3 0 4 9 0 1 0 4 4

uc-20e  
uc-4  
LBL-6850  
c.1

RECEIVED  
LAWRENCE  
BERKELEY LABORATORY

DEC 13 1977

LIBRARY AND  
DOCUMENTS SECTION

**For Reference**  
Not to be taken from this room

**Energy and Environment Division**

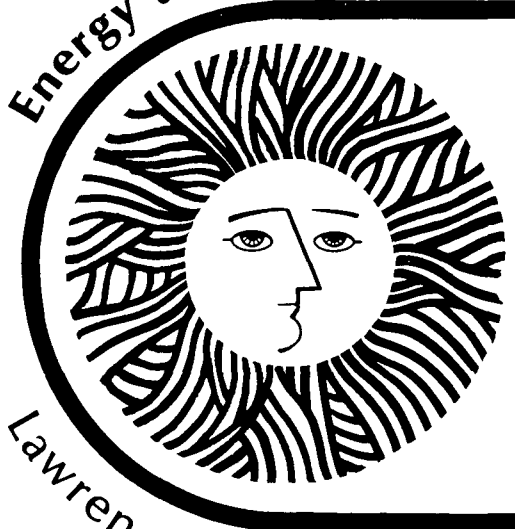

The Nature and Formation of  
Nitrogenous Air Pollutant Emissions  
from Combustion Systems

*Ronald Douglas Matthews*

October 1977

Lawrence Berkeley Laboratory University of California/Berkeley

Prepared for the U.S. Department of Energy under Contract No. W-7405-ENG-48

LBL-6850  
c.1

## **DISCLAIMER**

This document was prepared as an account of work sponsored by the United States Government. While this document is believed to contain correct information, neither the United States Government nor any agency thereof, nor the Regents of the University of California, nor any of their employees, makes any warranty, express or implied, or assumes any legal responsibility for the accuracy, completeness, or usefulness of any information, apparatus, product, or process disclosed, or represents that its use would not infringe privately owned rights. Reference herein to any specific commercial product, process, or service by its trade name, trademark, manufacturer, or otherwise, does not necessarily constitute or imply its endorsement, recommendation, or favoring by the United States Government or any agency thereof, or the Regents of the University of California. The views and opinions of authors expressed herein do not necessarily state or reflect those of the United States Government or any agency thereof or the Regents of the University of California.

0 0 0 0 4 9 0 1 0 4 5

THE NATURE AND FORMATION OF NITROGENOUS  
AIR POLLUTANT EMISSIONS FROM COMBUSTION SYSTEMS

by

Ronald Douglas Matthews\*  
Department of Mechanical Engineering  
University of California  
Berkeley, California

Principal Investigator: Robert F. Sawyer

\*Work performed as a Ph.D. Thesis. Author's present address:  
Professor R.D. Matthews, 144 MEB, University of Illinois,  
Urbana, Illinois 61801.

ABSTRACT

Recent investigations have revealed that many nitrogen containing species may be emitted from combustion systems. These sources are reviewed and are of concern because  $N_2$  is the only clearly innocuous nitrogenous species. The atmospheric chemistry and toxicology of the nitrogenous air pollutants which have been identified in the emissions from combustion systems is reviewed. Combustion generated N-species may be derived either from thermal fixation of  $N_2$  or from the use of fuels containing high concentrations of bound nitrogen. Many strategies which decrease emissions of thermal NO adversely affect emissions of fuel-derived NO. However, one particular combustion system has shown wide versatility and may be able to suppress traditional pollutants and fuel-NO simultaneously. This system, catalytic combustion, is the focus of the experimental portion of this investigation.

The emissions of fuel-derived N-species, especially NO, from catalytic combustors is investigated. Combustion parameters which are varied include equivalence ratio, adiabatic flame temperature, and fuel nitrogen concentration. For direct comparison with fuel rich catalytic combustion, the same species are monitored in the exhaust of a flat flame burner operating under the same conditions. This comparison allows

some estimation of the extent to which heterogeneous reactions are controlling the conversion of fuel nitrogen. Measurements of catalyst temperature, combustion efficiency, and emissions of CO, CO<sub>2</sub>, and UHC's are also presented.

The conversion of fuel nitrogen to NO is found to be strongly dependent on equivalence ratio, moderately dependent on fuel nitrogen concentration, and weakly dependent on the calculated adiabatic flame temperature. The NO yield is much lower for catalytic combustion than for gas phase combustion for all equivalence ratios except near stoichiometric. Contrasts in the behavior exhibited by homogeneous and catalytic combustion indicate that the fuel nitrogen conversion mechanism may be dominated by surface reactions during catalytic combustion. The evidence gathered in this investigation indicates that staged catalytic combustion may be preferable to homogeneous staged combustion or stoichiometric catalytic combustion.

## ACKNOWLEDGEMENTS

An investigation of this type can never be successfully completed without the dedication and help of a large number of people.

I would like to express my appreciation to Al Shaw, Dick Jensen, Vern Locke, Bill Nelson, and Frank Waymire for their aid in the design, construction and maintenance of the experimental apparatus. Linda Doppleb and Holly Ching are also to be thanked for the time and effort they expended constructing portions of the experimental apparatus. Dee Davis and Lawrence Brown were instrumental in obtaining necessary equipment.

Helpful discussions with Owen Smith, Bob Schefer, Bob Sawyer, and Nancy Brown were of inestimable value. Izak Namer, Bob Schefer and Linda Doppleb contributed toward the collection of data. Rebecca Palmer and Vija Kemanis are thanked for their dedication and understanding in the preparation of this manuscript.

Sincere appreciation is expressed to my thesis advisor, Bob Sawyer, for his aid, encouragement, and support. My association with him was the most valuable aspect of my graduate education.

Finally, I would like to thank the many friends I met during my tenure at Berkeley. Memories of these friendships will last much longer than will the consequences of this thesis.

Work performed under the auspices of the U. S. Department of Energy.

## TABLE OF CONTENTS

	<u>Page No.</u>
ABSTRACT . . . . .	i
ACKNOWLEDGEMENTS . . . . .	iii
TABLE OF CONTENTS . . . . .	iv
LIST OF FIGURES . . . . .	vii
LIST OF TABLES . . . . .	x
NOMENCLATURE . . . . .	xii
CHAPTER 1. Introduction . . . . .	1
CHAPTER 2. Atmospheric Chemistry and Toxicology of Nitrogenous Species . . . . .	5
2.1 The oxides of nitrogen . . . . .	7
a. Nitric oxide (NO) . . . . .	7
b. Nitrogen dioxide (NO <sub>2</sub> ) . . . . .	9
Atmospheric chemistry . . . . .	10
Toxicology I: acute exposure . . . . .	12
Toxicology II: chronic exposure . . . . .	15
Toxicology III: epidemiological studies . . . . .	17
Toxicology IV: synergistic effects . . . . .	17
Safe levels and ambient measurements . . . . .	20
c. Nitrous oxide (N <sub>2</sub> O) . . . . .	20
2.2 The cyanides . . . . .	24
a. Hydrogen cyanide (HCN) . . . . .	24
b. Nitriles . . . . .	28
2.3 The amines . . . . .	37
a. Ammonia (NH <sub>3</sub> ) . . . . .	38

TABLE OF CONTENTS (continued)

	<u>Page No.</u>
b. Nitrosamines . . . . .	41
c. The alkyl amines . . . . .	53
2.4 Other nitrogenous species . . . . .	54
2.5 Summary . . . . .	57
CHAPTER 3. Fuel Nitrogen Investigations . . . . .	60
3.1 Thermal and oxidative pyrolysis . . . . .	63
3.2 Fuel nitrogen investigations using premixed combustion systems . . . . .	70
3.3 Fuel nitrogen investigations using diffusion flame systems . . . . .	79
3.4 Models of the fuel nitrogen conversion mechanism . . .	86
3.5 Summary of fuel nitrogen research . . . . .	90
CHAPTER 4. Other Sources of Nitrogenous Emissions . . . . .	92
4.1 Previously unrecognized sources . . . . .	92
a. Spark ignition engines . . . . .	93
b. Compression ignition engines . . . . .	98
c. Gas turbines . . . . .	99
d. Power plants . . . . .	107
e. Experimental laboratory combustion devices and miscellaneous . . . . .	108
4.2 Air pollution control technology . . . . .	113
a. Heterogeneous techniques . . . . .	113
b. Homogeneous techniques . . . . .	116
4.3 Interaction of the air pollution and energy problems .	117
4.4 Noncombustion sources . . . . .	118
4.5 Summary . . . . .	121

## TABLE OF CONTENTS (continued)

	<u>Page No.</u>
CHAPTER 5. Potential Sources to the NO Emissions Problem . . . .	123
5.1 Lean combustion . . . . .	128
5.2 Catalytic combustion . . . . .	139
5.3 Summary . . . . .	145
CHAPTER 6. Experimental Objectives and Apparatus . . . . .	147
6.1 Detailed statement of experimental objectives . . . . .	147
6.2 Experimental apparatus . . . . .	151
a. Flow metering and measurement . . . . .	151
b. Combustion devices, housing and traversing mechanism	153
c. Probe and sample transfer system . . . . .	161
d. Measurement of NO by chemiluminescent analysis . .	165
e. Measurement of N <sub>2</sub> by gas chromatography with thermal conductivity detection . . . . .	170
f. Detection of other low molecular weight N-species .	170
CHAPTER 7. Results of the Flat Flame Burner Study . . . . .	172
7.1 Experimental results . . . . .	172
7.2 Discussion and summary . . . . .	176
CHAPTER 8. Results of the Catalytic Combustion Study . . . . .	179
8.1 Experimental results. . . . .	179
8.2 Discussion and summary . . . . .	192
CHAPTER 9 Summary and Conclusions . . . . .	195
REFERENCES . . . . .	203

## LIST OF FIGURES

<u>Figure No.</u>	<u>Page No.</u>
2-1. Effect of NO <sub>2</sub> on Visibility in the Bay Area . . . . .	11
2-2. Effect of Duration of Exposure on Toxic Dose . . . . .	14
3-1. Effect of Fuel/Air Mixing on the Relationship Between Fuel Nitrogen Concentration and Nitric Oxide Yield for Fuel Lean Flames . . . . .	83
3-2. Relationship Between Fuel Nitrogen Concentration and Fraction Converted to NO <sub>x</sub> . . . . .	85
4-1. Emissions of NO and NO <sub>2</sub> from Commercial Gas Turbines as a Function of Equivalence Ratio . . . . .	105
4-2. Centerline Axial Distribution of NO, NO <sub>2</sub> , and NO <sub>x</sub> in a Model Gas Turbine . . . . .	106
4-3. Effect of Extent of Fuel/Air Premixing on Formation of HCN, NH <sub>3</sub> , and NO in the Fuel Rich Primary Stage of a Two Stage Combustion System . . . . .	112
5-1. Potential for Oxides of Nitrogen Control Through Premixed Lean Combustion . . . . .	127
5-2. Relationship Between Equivalence Ratio and Formation of HCN, NH <sub>3</sub> , and NO in the Primary Combustion Chamber of a Two Stage Combustion System . . . . .	138
6-1. Effect of the Argon to Oxygen Ratio on the Relationship Between Equivalence Ratio and Adiabatic Flame Temperature . .	149
6-2. Experimental Apparatus . . . . .	152
6-3. Comparison of the Flat Flame Burner and the Catalytic Combustor . . . . .	154
6-4a. Closeup View of the Catalytic Combustor . . . . .	156
6-4b. The Catalytic Combustor in the Glass Housing . . . . .	157
6-5a. Drawing of a Rectangular Section of the Catalytic Combustor .	158
6-5b. Enlarged Drawing of a Section of the Catalytic Combustor . .	158
6-5c. SEM of catalytic combustor x133 . . . . .	159
6-5d. Platinum map of 6-5c . . . . .	159

LIST OF FIGURES (continued)

<u>Figure No.</u>	<u>Page No.</u>
6-5e. SEM Blowup of Nodule in Upper Left Quadrant of 6-5c x1100 . .	159
6-5f. SEM Blowup of Crack Visible in 6-5e Showing Right Side of Nodule x2500 . . . . .	159
6-5g. Extreme Blowup of the Crack Which Runs Left-to-Right in 6-5f x10,000 . . . . .	160
6-5h. Platinum Map of 6-5g . . . . .	160
6-5i. View of Edge of Catalyst Showing Surface Roughness x5000 . .	160
6-6a. Probe Traversing Mechanism, Motor Drive, and Microprobe Cooling Sleeve Attached to the Top End Plat . . . . .	162
6-6b. Another View of the Traversing Mechanism, Motor Drive, and Cooling Sleeve . . . . .	163
6-7. Quartz Gas Sampling Microprobe and Cooling Sleeve . . . . .	166
6-8. Relative Quenching Efficiencies of Common Third Bodies for Chemiluminescent NO Analysis . . . . .	168
7-1. Indicated NO Profiles Above the Flat Flame Burner for Various Flame Temperatures . . . . .	174
7-2. Effect of the Adiabatic Flame Temperature on the Conversion of Fuel-N to NO at Constant Equivalence Ratio and Fuel-N Fraction for Fuel Rich Homogeneous Combustion . . . . .	175
7-3. Effect of Fuel-N Concentration on the Conversion of Fuel-N to NO at Constant Equivalence Ratio and Adiabatic Flame Temperature for Fuel Rich Homogeneous Combustion . . . . .	177
8-1. Temperature Distribution in the Catalyst as a Function of Equivalence Ratio . . . . .	180
8-2. Comparison of Equilibrium and Measured Concentrations of CO, CO <sub>2</sub> , and C <sub>x</sub> H <sub>y</sub> as a Function of Equivalence Ratio . . . .	182
8-3. Combustion Efficiency as a Function of Equivalence Ratio . .	184
8-4. Effect of Equivalence Ratio on Conversion of Fuel-N to NO at Constant Adiabatic Flame Temperature and Fuel-N Concentration for Catalytic Combustion . . . . .	185

## LIST OF FIGURES (continued)

<u>Figure No.</u>	<u>Page No.</u>
8-5. Comparison of the Relationship of Equivalence Ratio and NO Yields Between Catalytic Combustion and Homogeneous Reaction . . . . .	186
8-6. Effect of Fuel Nitrogen Concentration on the Conversion of NH <sub>3</sub> to NO at Constant Equivalence Ratio and Adiabatic Flame Temperature . . . . .	188
8-7. Effect of the Adiabatic Flame Temperature on the Conversion of NH <sub>3</sub> to NO for Two Fuel-N Concentrations . . . . .	190
8-8. Effect of the Adiabatic Flame Temperature on the Conversion of NH <sub>3</sub> to NO for Lean, Stoichiometric and Rich Catalytic Combustion . . . . .	191

## LIST OF TABLES

<u>Table No.</u>	<u>Page No.</u>
1-1. Nationwide Source Emissions of Oxides of Nitrogen in 1970 . . .	2
2-1. Response to Exposure to NO <sub>2</sub> by Inhalation . . . . .	13
2-2. The Acute Toxicity of HCN . . . . .	29
2-3. The Acute Toxicity of Vinyl Cyanide . . . . .	33
2-4. The Acute Toxicity of Cyanogen, C <sub>2</sub> N <sub>2</sub> . . . . .	36
2-5. The Acute Toxicity of Ammonia, NH <sub>3</sub> . . . . .	40
2-6. Measurements of Nitrosamine Concentrations in Ambient Air . .	44
2-7. The Acute Toxicity of Dimethylnitrosamine . . . . .	50
2-8. Histopathology of Liver Tissue from Mice Exposed to Dimethylnitrosamine . . . . .	52
2-9. Nitrogenous Species for Which There is no Toxicological Data.	56
2-10. Adverse Effects of Nitrogenous Species . . . . .	59
3-1. Primary Energy Consumption by Sector and Source - July 1976 .	62
3-2. Typical Nitrogen Content of Fuels . . . . .	64
3-3. Nitrogen Compounds in Fossil Fuels . . . . .	65
3-4. Results of the Inert Pyrolysis Studies of Axworthy et al. (1975) and Axworthy and Dayan (1977) . . . . .	67
3-5. Investigations of Ammonia Oxidation in Premixed Combustion Systems . . . . .	72
3-6. Summary of Fuel Nitrogen Investigations in Premixed Combustion Systems in Which NO and NO <sub>2</sub> were the Only Nitrogenous Species Measured . . . . .	73
3-7. Fuel Nitrogen Investigations in Hydrocarbon-Free Systems . .	76
3-8. Summary of Fuel Nitrogen Investigations in Premixed Combustion Systems in Which Nitrogenous Species Other than NO <sub>x</sub> were Measured . . . . .	77
3-9. Summary of Fuel Nitrogen Investigations in Diffusion Flames .	80

LIST OF TABLES (continued)

<u>Table No.</u>	<u>Page No.</u>
4-1. Nitrogenous Emissions from Spark Ignition Engines . . . . .	94
4-2. Nitrogenous Emissions from Gas Turbines . . . . .	100
4-3. Percent of Organic Gas Turbine Emissions which Contain Nitrogen . . . . .	102
4-4. Distribution of Nitrogenous Species in Gas Turbine Exhaust.	103
4-5. Nationwide Source Emissions of Hydrocarbons, 1970 . . . . .	109
5-1. Effect of Thermal NO <sub>x</sub> Treatments on the NO Yield from Fuel-Nitrogen . . . . .	124
5-2. Lean Combustion . . . . .	129
5-3. Comparison of Methods for Attaining Lean Combustion in Spark Ignition Engines . . . . .	134
5-4. Advantages of Catalytically Stabilized Combustion . . . . .	140
5-5. Investigations of Very Lean Catalytic Combustion . . . . .	143

Nomenclature

CFR	Coordinated Fuel Research Council single cylinder piston engine
CLA	Chemiluminescent NO <sub>x</sub> analyzer
DMN	Dimethylnitrosamine
EI <sub>NO<sub>x</sub></sub>	Emissions Index (gms of NO <sub>x</sub> emitted/kg of fuel burned)
EMA	Commercial NO <sub>x</sub> analyzer
EPL	Estimated Permissible Level for continuous exposure of the general populace to a toxic agent (ppm or ppb)
FFB	Flat flame burner
FID	Flame ionization hydrocarbon detector
FN	Fuel nitrogen
GC	Gas chromatograph
GC-CLA	Gas chromatograph with chemiluminescent detection
GC-FID	Gas chromatograph with flame ionization detection
GC-MS	Gas chromatograph with mass spectrometric detection
IN	An active chemical intermediate species containing nitrogen
JSR	Jet stirred reactor
LC <sub>low</sub>	The lowest reported lethal concentration (Christensen and Luginbyhl, 1975)
LC <sub>50</sub>	Concentration of a toxic agent which is lethal to half of the exposed population (ppm)
LC <sub>100</sub>	Concentration of a toxic agent which is lethal to 100% of the exposed population (ppm)
M	Chemical species which acts as a third body during a reaction
MS	Mass spectrometer

NDIR	Nondispersive infrared analyzer
NDUV	Nondispersive ultraviolet analyzer
OD	Outside diameter
P	pressure (atm or Pa)
PAN	Peroxyacetylnitrate
ppm	part per million
ppb	part per billion
Pt/Pt-Rh	Platinum vs Platinum-Rhodium thermocouple
R	Reactive chemical species
RO	Reactive chemical species containing oxygen
SEM	Scanning electron micrograph
SPM	Spectrophotometer
T	Temperature ( $^{\circ}$ K)
$T_{AD}$	Theoretical adiabatic flame temperature
$T_{IN}$	Inlet temperature
TC	Thermocouple
$TC_{low}$	Lowest published toxic concentration as reported by Christensen and Luginbyhl (1975)
TLV	Threshold Limit Value (ppm)
$v_{IN}$	Inlet velocity
$\eta_b$	Combustion efficiency
[FN]	Fuel nitrogen fraction (fuel nitrogen concentration; concentration of nitrogen in fuel in % by wt.)

## CHAPTER 1

Introduction

Nitric oxide (NO) is generally recognized as being one of the most important air pollutants. Table 1-1 reveals that more than 95% of the 1970 nationwide emissions of NO were attributable to combustion sources. It has recently been shown that a wide variety of other nitrogenous species (N-species) are also emitted from combustion systems. Emission of these other nitrogenous species is a cause for concern because molecular nitrogen ( $N_2$ ) is the only clearly innocuous N-species. Other members of the family of gas phase nitrogenous species are odorants or lacrymators at low concentrations, affect visibility, play a role in the formation of photochemical smog, take part in atmospheric reactions which threaten the ozone layer, are capable of shifting the energy balance of the earth, are toxic at low levels, are precursors of carcinogens, or are directly carcinogenic. Chapter 2 is a discussion of the atmospheric chemistry and toxicology of the N-species which have been identified in the exhaust of combustion devices.

Combustion generated NO is primarily formed through thermal fixation of atmospheric nitrogen in high temperature combustion systems. It may also be formed during combustion of fuels which contain bound nitrogen. Coal, residual fuel oil, and many synthetic fuels contain significant concentrations of bound nitrogen. Because of the energy crisis and the resulting unavailability of clean fuels such as natural

TABLE 1-1

Nationwide Source Emissions of Oxides of Nitrogen in 1970  
(Cavender et al., 1973)

Source	Emissions 10 <sup>6</sup> tons/yr	Percent of Total
Transportation	11.7	51.3
Motor Vehicles	9.1	39.9
Gasoline	7.8	34.2
Diesel	1.3	5.7
Aircraft	0.4	1.8
Railroads	0.1	0.4
Vessels	0.2	0.9
Non-highway use of motor fuels	1.9	8.3
Fuel combustion in stationary sources	10.0	43.8
Coal	3.9	17.1
Fuel oil	1.3	5.7
Natural gas <sup>b</sup>	4.7	20.6
Wood	0.1	0.4
Industrial processes	0.2	0.9
Solide waste disposal	0.4	1.8
Miscellaneous	0.5	2.1
Forest fires	0.2	0.9
Structural fires	N <sup>a</sup>	---
Coal refuse burning	N	---
Agricultural burning	0.3	1.3
Total	22.8	100.0

<sup>a</sup>N = Negligible

<sup>b</sup>Includes LPG and kerosene

gas, these fuels are being relied upon to an ever increasing extent. For this reason "fuel nitrogen" is emerging as another major source of NO.

Currently, fuel nitrogen is responsible for approximately 50% of the NO emitted from stationary sources (Sarofim and Flagan, 1976). Application of this factor to the emissions from stationary, solid waste disposal, and miscellaneous sources as reported in Table 1-1 allows rough estimation of the relative importance of NO emissions due to fuel nitrogen and thermal fixation. The result of this calculation indicates that fuel nitrogen may have accounted for about 23% of the combustion generated NO in 1970. This problem will become more severe as the switch to high nitrogen fuels progresses. Previous investigations of the fuel nitrogen problem are reviewed in Chapter 3. Formation and emission of other N-species during the combustion of high nitrogen fuels is also discussed.

Nitrogenous compounds are also emitted from sources which are not related to the fuel nitrogen problem. Many of these combustion sources have not been recognized until relatively recently. Ironically, others are new sources which are the results of efforts to reduce air pollution. These sources of emissions of N-species are discussed in Chapter 4. For the sake of completeness, non-combustion sources are also briefly covered.

A discussion of potential solutions to the problem of NO emissions is presented in Chapter 5. The most promising techniques of NO reduction involve combustion of unusually fuel lean mixtures. Of the various methods of stabilizing lean combustion, catalytic combustion is the most attractive for many applications. By operating catalytic combustors under conditions where heterogeneous reactions are dominant, it

may be possible to minimize pollutant emissions even for overall near stoichiometric fuel/air mixtures. This case is of interest because commercial and industrial boilers are the systems which are most likely to utilize the fuels which contain bound nitrogen, and system thermal efficiency considerations dictate that they operate near stoichiometric.

There have been no reported investigations of fuel nitrogen conversion during near stoichiometric catalytic combustion. This problem is the focus of the experimental portion of this thesis research. A detailed discussion of the purpose of this investigation is presented in Chapter 6. The experimental and analytical apparatus are also discussed in this chapter.

Chapters 7 and 8 report the experimental results. Two combustion devices were used in this investigation: a flat flame burner and a catalytic combustor. Flat flame burners are devices in which the combustion reactions occur entirely in the gas phase and species evolution is kinetically determined. The results of the flat flame study are compared to the data obtained with the catalytic combustor. In this manner, the extent to which heterogeneous reactions dominate the fuel nitrogen conversion mechanism during catalytic combustion may be assessed.

A summary of this investigation and the presentation of the significant conclusions which may be drawn from it are given in Chapter 9.

## CHAPTER 2

Atmospheric Chemistry and Toxicology of Nitrogenous Species

A large number of nitrogen-containing species are currently being emitted into the atmosphere, and both their number and volume will continue to increase during the foreseeable future. The most important reason for concern over this trend is that  $N_2$  is the only clearly innocuous N-species. All other nitrogenous species are potentially dangerous from the perspective of atmospheric chemistry, or are toxic or carcinogenic.

This chapter will detail the toxicological symptomatology of the N-species which have been identified in the emissions from combustion systems. Secondary nitrogenous pollutants will be briefly discussed within the section dealing with primary pollutants. Relevant general information about each species will also be presented along with a discussion of the role that species plays in photochemical smog formation.

An "Estimated Permissible Level" for continuous exposure of the general population will be given and compared with levels that have been measured in the environment. This EPL is calculated from the equation (Handy and Schindler, 1976):

$$EPL = 1.65 \times 10^{-3} (TLV) \quad (2-1)$$

where TLV is the Threshold Limit Value for occupational exposure of healthy male adults for 8 hours/day, 5 days/week. The constant of proportionality intended to account for the differences in duration of

exposure as well as to include the effect of increased susceptibility of some segments of the population. That is, exposure to toxic agents tends to have a greater impact on the old, the very young, and the infirm than on healthy males, and Handy and Schindler have accounted for this effect in Equation 2-1. However, it is frequently suggested that the TLV's may need downward adjustment. The inclusion of women of child-bearing age into the workforce is proposed as one reason for this suggestion. In some cases, low factors of safety were used in the establishment of the present TLV's, and this has caused concern in some quarters. Finally, the American TLV is based on the concentration which leads to the onset of adverse biological effects. It might be more cautious to base it on the lowest concentration which causes a change in any biological function, as is the philosophy in some other countries. For example, the United States TLV for hydrogen cyanide is 10 ppm, while it is 2.7 ppm in Czechoslovakia and 0.3 ppm in the USSR.

Epidemiological studies offer the most information about the effects of semi-continuous exposure of humans to toxic agents. Unfortunately, epidemiological studies have only been done for  $\text{NO}_2$  of all the N-species identified in the emissions from combustion systems. Of the other toxicological data that have been gathered, human data are more informative than animal data and chronic data are less ambiguous than acute data. However, for many N-species there is very little toxicological data of any kind. All of these types of data can yield some useful information, and the relationships between the results of the various kinds of toxicological studies are best expressed by the example of  $\text{NO}_2$ . For this reason, all of the studies of  $\text{NO}_2$  toxicology will be briefly reviewed. This should indicate how the sparse data which are available for some N-species may be used to estimate the public health impact of semi-

continuous exposure to very low levels.

## 2.1 The Oxides of Nitrogen

Early investigations of the toxicology of the oxides of nitrogen used red fuming nitric acid as a source. Red fuming nitric acid produces a complex mixture of the oxides of nitrogen. This made detailed toxicological investigations of any specific oxide of nitrogen difficult. More recent studies have employed pure sources, and these investigations will be discussed in the following paragraphs.

### a. Nitric oxide (NO)

Nitric oxide is the N-species which is emitted in the highest concentrations and from the greatest number of combustion sources. It is a colorless, odorless gas.

#### Atmospheric chemistry

NO is rapidly oxidized in the atmosphere to form NO<sub>2</sub> via the overall reaction:



The evolved NO<sub>2</sub> then takes part in the following set of reactions, which are important in the genesis of photochemical smog.



Reaction (2-2) is catalyzed in the presence of hydrocarbons via reactions such as:

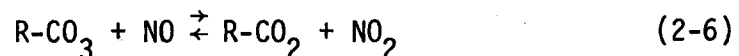

where R is an alkyl hydrocarbon which is formed via a complex mechanism which is initiated by ozone attack on atmospheric hydrocarbons. Peroxyacyl nitrate is formed through a reaction similar to (2-6):

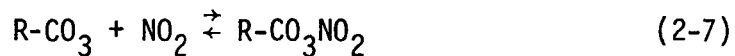

Because NO plays such a significant role in the formation of photochemical smog, it is an extremely important primary pollutant.

The discovery that the oxides of nitrogen can catalytically reduce ozone (Crutzen, 1970; Johnston, 1971) created concerns for the effects of supersonic transport aircraft designed to fly in the stratospheric ozone layer. It was calculated that the emissions of NO from a fleet of 500 SST's would destroy 13% of the ozone layer within a century (Grobecker, et al., 1974).

#### Toxicology

There is very little toxicological data concerning high exposures and the acute toxicity of NO to man or animals. Mice exposed to more than 300 ppm become cyanotic, staggering, and depressed before succumbing to convulsions and death. Central nervous system damage is suggested. However, the damage associated with exposure to NO is completely reversible, even into the convulsive stage (Gray, 1959).

Rodale (1964) reports that NO has an affinity for hemoglobin 300,000 times stronger than O<sub>2</sub> and 1000 times greater than CO. Gibson and Roughton (1957) measure the affinity of NO for hemoglobin as 1500 times that of CO<sub>2</sub>. However, Battigelli (1971) cites conflicting evidence over whether methemoglobin or nitric oxide hemoglobin is formed. In either case, the vital ability of the blood to transport oxygen may be significantly decreased during exposure to NO.

There have been no significant studies of the toxicological effects of chronic exposure to ambient levels of NO. However, preliminary studies have shown that ambient NO and NO<sub>2</sub> may react with anthro-

pogenic and/or naturally occurring amines to form the highly carcinogenic nitrosamines. This subject will be discussed in more detail in the sections dealing with nitrogen dioxide (2.1.b) and nitrosamines (2.3.b).

A calculated safe level for chronic exposure of the general populace to NO would be 0.040 ppm, based on the TLV of 25 ppm which is considered to be safe for exposure of healthy adult males for 8 hours/day, 5 days/week. Ambient levels in Los Angeles have reached concentrations as high as 3.7 ppm on an hourly averaging basis (Williamson, 1973). Annual average levels ranging from 0.02 to 0.10 ppm with peak values of 0.54-2.64 ppm for 5 minutes have been reported for metropolitan areas in the United States (Tebbens, 1966). It is therefore seen that ambient levels of NO often exceed theoretically safe levels, and over short periods of time the safe levels may be exceeded by several orders of magnitude. These maximum values are lower than the TLV, but the most susceptible elements of the population are exposed. Because of this, and the fact that the safe levels are exceeded year round in some urban areas, it might be concluded that NO exposure is a significant public health hazard in the United States. This conclusion assumes that the sparse toxicological data has resulted in a TLV which is about right or is too high, and that Equation 2-1 is valid for chronic exposure to NO.

b. Nitrogen dioxide (NO<sub>2</sub>)

Nitrogen dioxide absorbs radiation in the 0.38-0.60 micron wavelength range. This characteristic is responsible for its brownish appearance. Recent studies have revealed that it may be given off from combustion systems, but it is primarily formed in the atmosphere from the oxidation of NO. The conversion of NO to NO<sub>2</sub> is enhanced by the

presence of CO and hydrocarbons, especially peroxy radicals.

### Atmospheric chemistry

NO<sub>2</sub> affects smog formation in a number of ways. First, since it has a brownish color, atmospheric levels as low as 250 ppb can affect visibility. Figure 2-1 illustrates this characteristic by comparing visibility in the San Francisco Bay Area on a clear day with the same view on a day when light absorption by NO<sub>2</sub> has significantly decreased visibility. NO<sub>2</sub> also contributes to air pollution because it is a necessary intermediate in the formation of the peroxyacyl nitrates (see section 2.1.a). Members of the PAN family are toxic, can cause eye irritation at concentrations as low as 0.005 ppm, and are considered to be the oxidants most responsible for material and plant damage. The PAN's are capable of damaging some plants after exposure to 0.01 to 0.05 ppm for as little as one hour (Williamson, 1973).

Because NO<sub>2</sub> is a strong oxidant, it is directly capable of decreasing the fruit yield of citrus trees exposed to 0.5 ppm for several months. (Williamson, 1973).

In addition to the production of PAN, NO<sub>2</sub> indirectly affects smog because it is finally removed from the atmosphere through reactions which produce aerosols (Renzetti and Doyle, 1960). These particulates are another major cause of the reduction of visibility associated with smog.

The final indirect effect of the presence of NO<sub>2</sub> in the atmosphere lies in its ability to form other oxides of nitrogen. It has a tendency to polymerize, forming its dimer, nitrogen tetroxide (N<sub>2</sub>O<sub>4</sub>) and

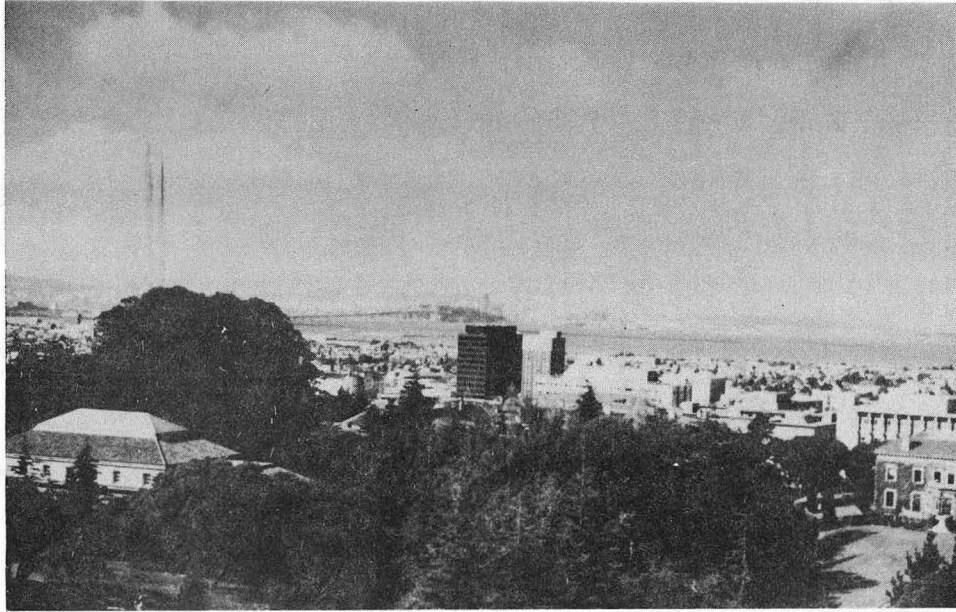

(a)

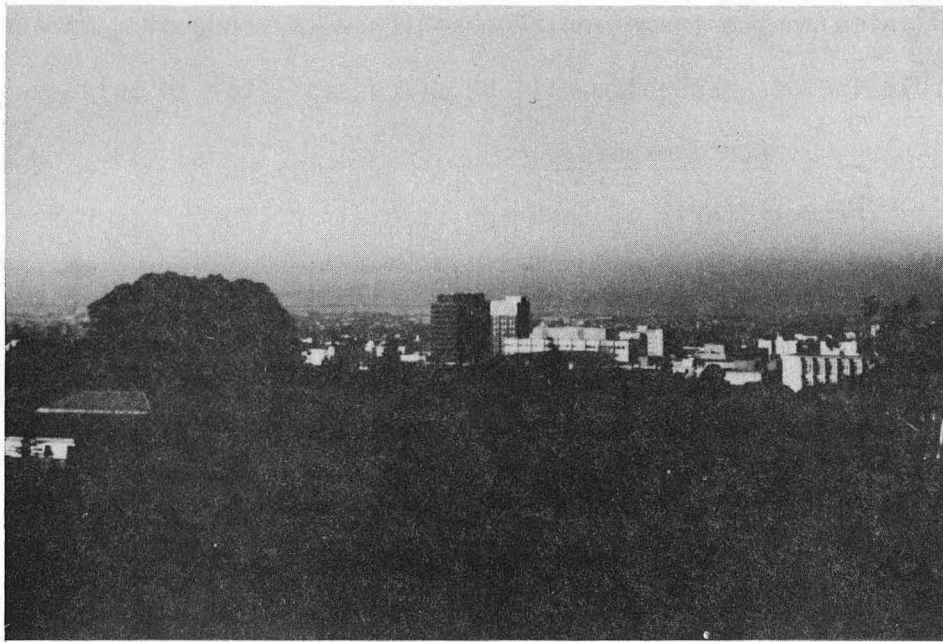

XBB 770-11498

(b)

Figure 2-1. Effect of  $\text{NO}_2$  on visibility in the Bay Area  
a) View of San Francisco from Berkeley on a clear day  
b) Obstruction of visibility by a brown layer of  $\text{NO}_2$

also may be oxidized to nitrogen trioxide ( $N_2O_3$ ).  $N_2O_3$  and  $N_2O_4$  are toxic but relatively unstable.

The major source of nitric acid ( $HNO_3$ ) in the atmosphere is through the reaction (Wang, et al., 1976):

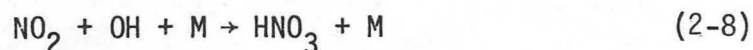

Nitric acid is a powerful oxidizing agent. It is even more toxic than  $NO_2$  and has a TLV of 2 ppm. Perturbations in global  $HNO_3$  levels can alter the earth's surface temperature by changing the "greenhouse effect" (for further discussion, see 2.1.c and 2.2.a). The estimated lifetime of  $HNO_3$  is 10 days. An EPL for  $HNO_3$  is 3.3 ppb and it is presently found in the atmosphere in concentrations ranging from 1.0 ppb at sea level to 10.0 ppb at 25 km (CIAP Monograph 1, 1975).

Nitrous acid ( $HNO_2$ ) is also formed from atmospheric  $NO_2$ . It has been implicated in the formation of the highly carcinogenic nitrosamines, and its role in this mechanism will be discussed later in this chapter.

#### Toxicology I: Acute exposure

$NO_2$  is the most toxic of the regulated air pollutants. Data on acute, toxic exposures is given in Table 2-1. The German study cited by Christensen and Luginbyhl (1975) presents what is apparently the lowest toxic concentration for human exposure that has been published. However, they did not provide information on the duration of the exposure.

Investigations involving exposure of rats illustrate the relationship between toxic dose and duration of exposure as shown in Figure 2-2. As the dose increases, the exposure time necessary for that concentration to be lethal to 50% of the exposed population decreases.

Table 2-1.

Response to Exposure to NO<sub>2</sub> by Inhalation

<u>Subject</u>	<u>Dose/Duration</u>	<u>Effect</u>	<u>Reference</u>
Human	64 ppm	TC <sub>100</sub>	Christensen & Luginbyl (1975)
Mouse	250 ppm/30min	LC <sub>100</sub>	
Rabbit	315 ppm/15min	LC <sub>50</sub>	Carson, et al. (1962)
Monkey	44 ppm/6 hr	LC <sub>100</sub>	Aerospace Medical Research Labs
Rat	See Figure 5-1		

00004901059  
-13-

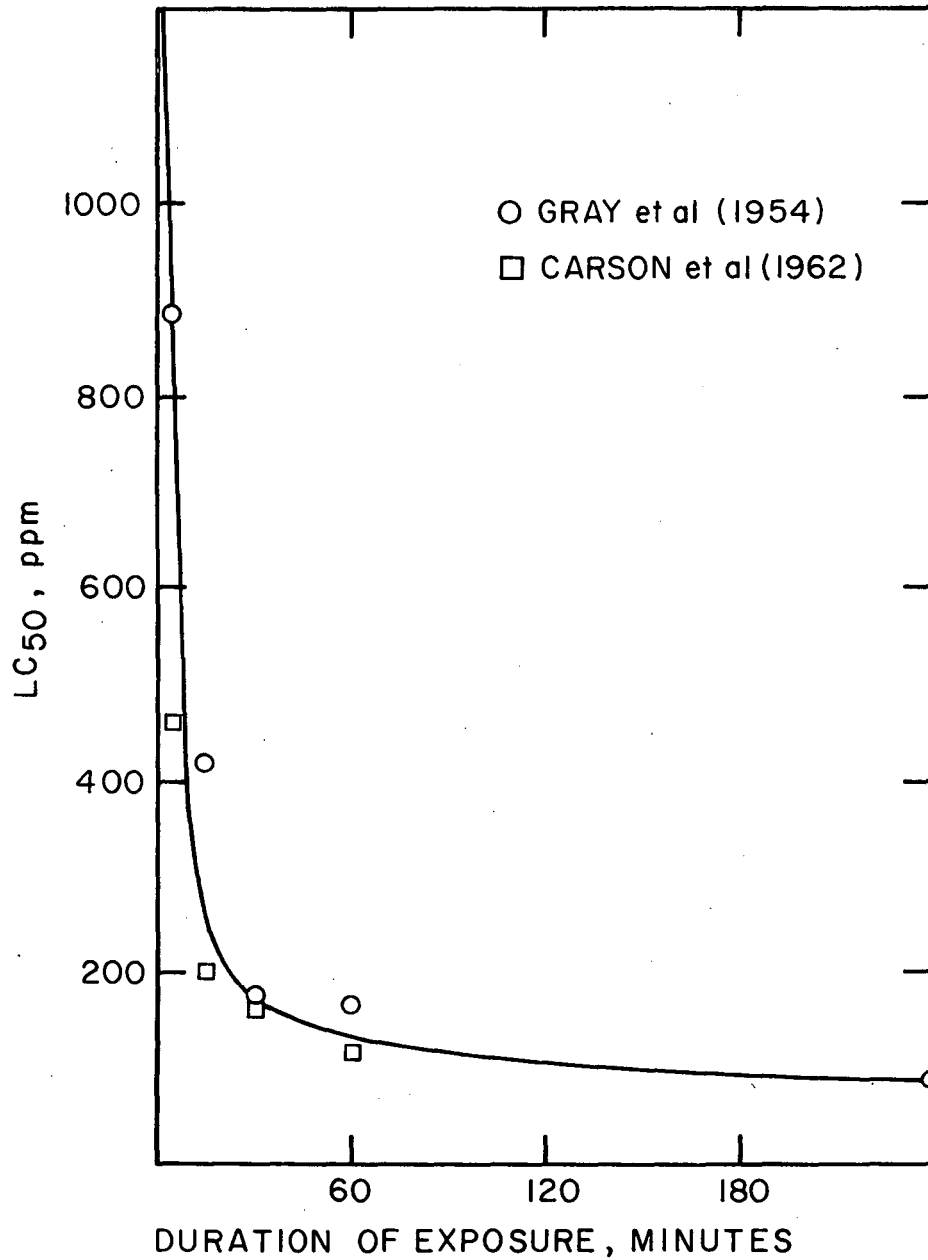

Figure 2-2. Effect of Duration of Exposure on Toxic Dose. The specific curve is for exposure of rats to  $\text{NO}_2$ , but similar curves can be generated for most toxic species. The  $\text{LC}_{50}$  is the concentration that is lethal to 50% of the exposed population.

The major symptoms included eye irritation, respiratory distress, and body weight reduction. Death appeared to be due to pulmonary edema. Gray, et al. (1954) found that a 20° F rise in ambient temperature increased the toxicity by 25%.

NO<sub>2</sub> is insoluble in water and therefore can reach the deep pulmonary and alveolar surfaces. Exposure of humans to very high concentrations will cause laryngospasm, violent cough, slowed breathing, syncope (unconsciousness due to loss of blood flow to the brain), shock, and death. If the exposure is slightly less severe, pulmonary edema will result. In this case, there may be no symptoms for the first 5 - 72 hours except for a short initial period involving chest pains, cough, and general discomfort. After this latent period, fatigue, uneasiness, cough, and dyspnea (tightness in the chest) will slowly appear as the edema develops. Anxiety, confusion, lethargy, tracheobronchitis, cyanosis, and loss of consciousness will occur as the edema leads to rales. Contradictorily, this condition has been reported to be either fatal or fully reversible. Hemorrhaging and bronchial secretions may result from this and less severe exposures. Furthermore, bronchopneumonia and pneumonia are likely to result from exposure to relatively high concentrations of NO<sub>2</sub> because of the resultant lowered resistance to bacterial and viral infection.

#### Toxicology II: Chronic exposure

Many studies have investigated the effect of long term exposure to relatively low levels of NO<sub>2</sub>. Squirrel monkeys exposed to 5 ppm for 2 months and 10 ppm for one month had a greater susceptibility to pneumonia than did a control group (Henry, et al., 1970). Rats exposed to 10 ppm developed gross modifications of the chest cage and

began to die of respiratory ailments after 16 months of exposure (Freeman, et al., 1969a). Gray, et al. (1952) found that animals exposed 4 hours/day, 5 days/week to NO<sub>2</sub> levels between 9 and 14 ppm exhibited changes in lung pathology. At that time, the TLV for NO<sub>2</sub> was 10 ppm but it has since been reduced to 5 ppm. Note that the factor of safety is not large given the relative paucity of experimental data. Ten to twenty ppm is reported to irritate the eyes, nose and upper respiratory tract of human subjects (Patty, 1949). Pulmonary edema is expected for chronic exposures of 9.3 ppm and above (Battigelli, 1971). Occupational exposure of Russian workers to approximately 2.8 ppm NO<sub>2</sub> for periods ranging from three to five years resulted in emphysema, probable chronic bronchitis, and reduced blood catalase levels (Vigdortschik, et al., 1937). It has been noted that this exposure may have been to a mixture of oxides of nitrogen instead of NO<sub>2</sub> solely (Documentation of TLV's, 1971). However, a study of rats exposed to 0.5 ppm NO<sub>2</sub> for six weeks confirmed that blood catalase values could be significantly reduced (Ripperton and Johnston, 1959). In a separate study of rats, exposure to 0.8 ppm resulted in a 20% decrease in breathing frequency, thickening of the epithelium, loss of cilia, and other tissue changes suggestive of the early stages of emphysema (Freeman, et al., 1969b). Freeman's findings were confirmed by other animal studies in which exposure to 0.5 ppm for several weeks also resulted in disappearance of cilia, changes in the bronchiolar epithelium, and distention of the alveolar walls (Blair, et al., 1969). Again, these symptoms resemble the early stages of emphysema.

### Toxicology III: Epidemiological studies

Exposure to ambient levels of  $\text{NO}_2$  has also been shown to lead to increased incidence of respiratory infection. This observation demonstrates that symptoms of acute poisoning may indicate effects of chronic exposure. Specifically a study in Chatanooga, Tennessee found increased incidence of acute respiratory illness among school children living in areas with high ambient  $\text{NO}_2$  concentrations (Shy, 1970a, 1970b). There is argument over the magnitude of the exposure, since it is believed that the  $\text{NO}_2$  quantification system may not have been accurate. However, there is no argument over the association between  $\text{NO}_2$  and pulmonary disease among children.

### Toxicology IV: Synergistic effects

Epidemiological studies of the effects of air pollution are complicated by possible synergistic effects between various pollutants. Indeed, Boren (1964) has demonstrated that mice exposed to  $\text{NO}_2$  adsorbed on carbon particulates are much more severely affected than are mice chronically exposed to carbon particulates or to 25 ppm of  $\text{NO}_2$  alone. Of the 20 mice exposed 6 hours per day, 5 days per week for 3 months to carbon particulates saturated with  $\text{NO}_2$ , 65% died and the remainder had emphysema but no pulmonary edema. None of the 53 mice chronically exposed to airborne carbon particulates died or showed signs of tissue damage, edema or emphysema. All of the mice repeatedly exposed to 25 ppm  $\text{NO}_2$  (30 minutes per day, 5 days per week, for 4.5 months) survived and appeared to be healthy, with no edema or emphysema apparent upon autopsy. The findings of this report indicate that  $\text{NO}_2$  exposure in urban areas is even more dangerous than laboratory

experiments would suggest because the particulates in urban atmospheres can effectively concentrate  $\text{NO}_2$  yielding a much larger effective dose.

A possible synergistic effect between  $\text{NO}_2$  and  $\text{O}_3$  was investigated by Hackney, et al. (1975). No synergistic effects were exhibited by healthy white males exposed to 0.5 ppm  $\text{O}_3$  and 0.3 ppm  $\text{NO}_2$ . However the investigators noted that this finding did not preclude the possibility that such effects might occur at higher  $\text{NO}_2$  and/or  $\text{O}_3$  levels, at higher humidity, or with subjects who were more susceptible to respiratory distress.

An even more insidious synergistic effect has been indicated. A correlation between urban atmospheric  $\text{NO}_2$  levels and lung and other respiratory cancers has been well documented (Hickey, et al., 1970; Miller, 1975). Of course,  $\text{NO}_2$  itself is not carcinogenic. However, recent investigations have revealed a number of mechanisms through which  $\text{NO}_2$  may combine with amines to form nitrosamines. The toxicology of the nitrosamines will be discussed in section 5.2.b. For the present, it should be sufficient to report that the World Health Organization recognizes the N-nitroso compounds as the most powerful carcinogens yet tested against experimental animals (Bogovski, 1973), and the Environmental Protection Agency has stated that "As a family of carcinogens, the nitrosamines have no equals" (U.S. EPA, 1974). There are two routes of nitrosation of  $\text{NO}_2$ : in vivo and in the atmosphere.

Hanst, et al. (1976) have found that 1 ppm  $\text{NO}$ , 4 ppm  $\text{NO}_2$ , and 1 ppm dimethylamine  $(\text{CH}_3)_2\text{NH}$ , react to form N-nitroso dimethylamine (also called dimethylnitrosamine) at a dimethylamine disappearance rate of about 1% per minute. Because they estimated the photolysis half-life of this nitrosamine to be between one-half and one hour, they con-

cluded that the nitrosation rate was too slow to yield appreciable quantities of nitrosamines. However, if the mixture was 1 ppm  $(\text{CH}_3)_2\text{NH}$ , 2 ppm  $\text{NO}$ , 2 ppm  $\text{NO}_2$ , 1.3%  $\text{H}_2\text{O}$ , and .5 ppm nitrous acid ( $\text{HNO}_2$ ), the rate was accelerated to 4% per minute. They calculated that .18 ppm  $\text{NO}$ , .02 ppm  $\text{NO}_2$ , and 2.0%  $\text{H}_2\text{O}$  would form .01 ppm  $\text{HNO}_2$  at equilibrium under night time conditions. This mixture could then lead to the disappearance of  $(\text{CH}_3)_2\text{NH}$  at 6%/hour producing significant concentrations of nitrosamine which, in turn, would disappear after sunrise at 50%/hour. Bretschneider and Matz (1974) found that the level of dimethylnitrosamine in the air within a German factory was dependent, almost exclusively, on the  $\text{NO}_2$  concentration, with the level of dimethylamine having very little effect as long as it was present. It should be noted that the  $\text{NO}_x$  concentration in the German study never exceeded 0.04 ppm, much less than the maximum levels reached in urban areas. Miller (1975) concludes that the formation of nitrosamines depends on the amine concentration only to the first power but on the  $\text{NO}_2$  concentration to the second or third power. Sources of atmospheric amines are detailed in Chapters 3 and 4, and toxicology is covered in section 2.3.

$\text{NO}_2$  may also be nitrosated in vivo. Although this mechanism has been noted by many investigators (Miller, 1975; Shapley, 1976; Fine, et al., 1974; EPA Summary Report on Nitrosamines, 1977), only Kant (1970) has demonstrated it experimentally. He bubbled a gas mixture containing 15%  $\text{NO}_2$  through rat lung homogenates and observed the formation of nitrosamines. Fine, et al. (1974) have noted that the efficiency of conversion of atmospheric  $\text{NO}_x$  to nitrosamines in vivo

has not been established. However, they calculated that if the conversion reactions are only 10% efficient, 10-14  $\mu\text{g}$  of nitrosamines will be formed in the body daily. This compares to inhalation of 0.8  $\mu\text{g}$  from a pack of cigarettes and 0.5  $\mu\text{g}$  from 4 slices of cooked bacon (Shapley, 1976). The EPA (1977) tentatively agrees, stating that the burden of nitrosamines formed (from nitrites as well as  $\text{NO}_x$ ) in vivo could conceivably be greater than all other sources combined.

#### Safe levels and ambient measurements

The Federal Air Quality Standard for  $\text{NO}_2$  is 0.05 ppm annual average, a value that is often exceeded in metropolitan areas. Peak concentrations for six urban cities in the U.S. range from 0.15 to 0.38 ppm for a 5 minute averaging period. In Los Angeles, from 1963 to 1965, the maximum hourly average for  $\text{NO}_2$  was 1.3 ppm (Williamson, 1973). Annual averages range from 0.02 to 0.05 ppm (Tebbens, 1966). It should be noted that the Federal Air Quality Standard for  $\text{NO}_2$  was set before the nitrosamine problem was recognized. As Miller (1975) points out, optimum control of nitrosamines may be obtained most efficiently through control of atmospheric  $\text{NO}_2$ . If this is the case, then the Federal Air Quality Standard for  $\text{NO}_2$  would have to be revised downward. In other words, the hazard posed by  $\text{NO}_2$  in the environment may be even more severe than had been previously realized.

#### c. Nitrous oxide ( $\text{N}_2\text{O}$ )

Nitrous oxide has a very large natural background value of 0.3 ppm (Williamson, 1973). As discussed in section 4.3, the residence time for  $\text{N}_2\text{O}$  in the atmosphere has been estimated as between 5 years (Hahn, 1974, 1975) and 170 years (Johnston and Selwyn, 1975). Craig et al.

(1976) have found that  $N_2O$  levels over the Pacific Ocean have increased by 1.5% over the last decade.

Nitrous oxide is an unusual nitrogenous species from a health perspective. It is the only N-species, other than  $N_2$ , which is relatively innocuous. In concentrations in excess of 80% it is an effective general anesthetic and is commonly used in the medical and dental practices. At these concentrations, it produces a rapid narcosis which is preceded by, as Battigelli (1971) puts it, "decreased self-control and consequent shallowness of mood resulting in exhilaration." This phenomenon is responsible for the synonym "laughing gas." Of those very few deaths which have been linked to  $N_2O$ , it is probable that most, if not all, were due to anoxia, or lack of oxygen. The benign effects of human exposure to  $N_2O$  do not seem to be evidenced in certain animal species. McKean (1934) found that  $N_2O$  could excite the carotid baroreceptors in dogs, resulting in death by cardiac and respiratory arrest. On the other hand, Berkowitz and coworkers (1976), in studies on mice, found that nitrous oxide produces an analgesia with characteristics similar to the action of opiates. They found that 55%  $N_2O$  in  $O_2$  could produce a 50% analgesia and concluded that  $N_2O$  releases or potentiates an endogenous analgesic or opiate, or that the narcotic antagonists used in the study might have previously unrecognized analgesic antagonist properties. In summary, the evidence as a whole indicates that  $N_2O$  has a benign or possibly a benevolent effect on exposed humans.

However, even though  $N_2O$  does not adversely effect the public

health, it may still be a significant air pollutant. The following paragraphs will discuss the justifications for this conclusion.

It has been shown that  $N_2O$  is converted to  $NO$  in the stratosphere (Crutzen, 1971; McElroy and McConnell, 1971; Nicolet and Vergison, 1971) via the reaction



Reaction (2-9) is most rapid in the ozone layer because of the simultaneous reaction



which provides atomic oxygen for the  $N_2O$  destruction reaction. As mentioned in 2.1.a, this  $NO$  will catalytically reduce  $O_3$  (Crutzen, 1970; Johnston, 1971). In short, nitrous oxide may play a significant role in the depletion of the ozone layer. Shapley's (1977) brief review\* reveals as yet unpublished calculations made by Johnston which show that the  $N_2O$  problem is at least as significant as the hazard posed by a fleet of 500 SST's or continued use of aerosol spray cans which contain chlorofluorocarbons.

The second reason for concern over increasing levels of atmospheric  $N_2O$  has been identified by Wang, et al. (1976). These researchers have calculated that an increase in atmospheric  $N_2O$  by a factor of two would cause an increase in the surface temperature of the earth of  $0.7^\circ K$ . This is due to the "greenhouse effect" which is associated with chemical species which have strong radiative

---

\*See Johnston (1977) for a letter-to-the-editor which is critical of Shapley's article.

absorbance bands in the 7 - 14  $\mu\text{m}$  wavelength region. The authors explain that global average surface temperature changes greater than  $0.1^\circ\text{K}$  are potentially significant and that major climatic changes are generally associated with changes of the order of  $1.0^\circ\text{K}$ . It has been estimated that worldwide  $\text{N}_2\text{O}$  levels could double by the year 2020 based on the use of nitrogen-containing fertilizers as the major source. If  $\text{N}_2\text{O}$  emissions from combustion systems are as significant as recent investigations indicate, this estimate might prove to be too low. In addition to  $\text{N}_2\text{O}$ , the authors calculated the levels of  $\text{CH}_4$ ,  $\text{NH}_3$ ,  $\text{HNO}_3$ ,  $\text{C}_2\text{H}_4\text{SO}_2$ ,  $\text{CCl}_2\text{F}_2$ ,  $\text{CCl}_3\text{F}$ ,  $\text{CH}_3\text{Cl}$ , and  $\text{CCl}_4$ . Nitrous oxide was shown to be the most important trace gas other than the natural constituents  $\text{H}_2\text{O}$ ,  $\text{CO}_2$ , and  $\text{O}_3$ . Ammonia and nitric acid each displayed the ability to change the global average surface temperature by  $0.1^\circ\text{K}$  if the present concentrations are doubled. Thus, since the effects are basically additive, simultaneously doubling of the nitrogenous species  $\text{N}_2\text{O}$ ,  $\text{NH}_3$ , and  $\text{HNO}_3$  would result in a surface temperature increase of  $0.9^\circ\text{K}$ . The greenhouse effect is, therefore, a significant reason why emissions of  $\text{N}_2\text{O}$  (and  $\text{NH}_3$  and  $\text{HNO}_3$ ) from combustion systems cannot be ignored.

It should be noted that these two mechanisms would tend to have the same general effect on the earth's surface temperature. That is, depletion of the ozone layer would cause the global average surface temperature to increase because less of the incoming solar radiation would be absorbed at altitude. An increase in atmospheric  $\text{N}_2\text{O}$  would also cause the surface temperature to increase because energy radiated from the earth and lower atmosphere would be trapped by  $\text{N}_2\text{O}$ . Therefore, the two separate mechanisms combine to magnify the  $\text{N}_2\text{O}$  problem.

An estimate of the safe level for atmospheric  $N_2O$  cannot be made by the procedure which was explained in the introduction to this chapter. There is no TLV or  $LD_{50}$  because there are no toxic effects associated with exposure to  $N_2O$ . However, since it plays an important role in atmospheric chemistry it is to be hoped that ambient levels will not change significantly from the present levels.

## 2.2 The Cyanides

The cyanides are the classification of species which contain the cyano group, CN. Of these, HCN is emitted from the largest number of sources and appears to be the most important pollutant in this category. Therefore, it will be discussed first and in the greatest detail. The last part of this section will contain brief discussions of the other cyanides which have been identified in the emissions from combustion systems, as covered in Chapters 3 and 4.

### a. Hydrogen Cyanide (HCN):

Hydrogen cyanide is a colorless, poisonous gas which is readily absorbed through the skin and can be smelled as bitter almonds at levels as low as 1 ppm. As a toxin, it enjoys widespread notoriety for several reasons: it is the poisonous component of lethal mushrooms and is also found in the seeds of cherries, plums, peaches, apricots, apples, and pears; before the unofficial moratorium on capital punishment in the U.S. began in 1967, HCN was responsible for the deaths of many inmates in gas chambers across the country; it was used in the First World War as a fumigant for clothes, and more

importantly, as a nerve gas (Prentiss, 1951). Although it is emitted in many industrial operations and was a major source of chemical intoxication 60 years ago (Gleason et al., 1963), it has not been of great concern to industrial toxicologists within the past decade or two. However, the new sources of HCN emissions discussed in Chapters 3 and 4 may cause HCN to become a significant atmospheric contaminant in the foreseeable future.

When encountered in high concentrations, HCN combines in the tissues with oxidative enzymes such as cytochrome oxidase (Morgan and Seaton, 1975; Wolfsie, et al., 1959). Because of this,  $O_2$  cannot be abstracted from the bloodstream, resulting in a bright red coloration of the venous blood. Vital functions remain suspended as long as the  $CN^-$  ion is present. Because the nervous system and brain are most sensitive to oxygen starvation, they are most critically affected. The body's tendency to compensate for decreased oxygen carrying capacity by increasing the blood flow rate puts an added burden on the heart and may result in unexpected blackouts (Weatherhold et al, 1960). This "internal asphyxiation", combined with the fact that HCN is also absorbed through the skin, explains the extreme rapidity of cyanide poisoning. Symptoms of acute cyanide poisoning may include constriction of the throat, vomiting, vertigo, palpitations, intense dyspnea, unconsciousness, violent convulsions (either tonic or epileptic), opisthotonos or trismus, clenched hands, and feeble and irregular heartbeat which continues after respiration has ceased. Central nervous system involvement is noticeable. Death is due to respiratory arrest. Post mortem examination reveals coagulation of

the blood and hemorrhages, especially of the pleura and pericardium (Underhill and Koppayani, 1936; Valade, 1952). Cyanmethemoglobin is present. Valade (1952) examined dogs who had died of HCN poisoning and found "intense vasodilation with hemorrhages in the central nervous system in the frontal, parietal, and temporal cortex of the brain and also in the central nuclei, bulb, and cervical cord. Degeneration was found in the nerve cells." He suggests that exposure to even mild concentrations of HCN may lead to nervous damage and sequelae after long term exposure.

In nonlethal concentrations,  $CN^-$  can be rapidly destroyed in the body by combining with available sulfur to form the relatively nontoxic sulfocyanides (Henderson and Haggard, 1943), particularly thiocyanate (Gleason, et al., 1963), which are then eliminated in the urine and saliva. Symptoms of chronic poisoning may include headache, dizziness, pallor, anorexia (loss of appetite), and other gastrointestinal symptoms, difficult respiration, asthenia (weakness), nausea, irritation of the upper respiratory tract and eyes, unsteadiness of gait, peripheral neuritis, and thyroid changes including goiter.

The thyroid changes are possibly caused by the presence of the thiocyanate ion ( $CNS^-$ ) which is produced during the continuous detoxification of  $CN^-$  in long term exposures (Hardy, et al., 1950). Because excretion of thiocyanate by the kidneys is irregular, thiocyanate levels in the extracellular fluids may progressively increase during chronic exposure. Studies have shown that thiocyanate itself can have toxic effects and this may explain chronic cyanide poisoning (Hamilton and Hardy, 1974; Wolfsie, 1959). It has also been shown

that thiocyanate can catalytically accelerate the in vivo formation of nitrosamines (Mirvish, et al., 1974; Boyland and Walker, 1974). The  $\text{CNS}^-$  increases the rate of nitrosation of amines through the formation of nitrosyl thiocyanate,  $\text{ON}\cdot\text{CNS}$ . The rate of nitrosamine formation is then proportional to the concentration of thiocyanate, amine, and  $\text{HNO}_2$ , all to the first power. This nitrosamine formation mechanism can compete favorably with the  $\text{HNO}_2$  mechanism mentioned in 5.1.b. Both mechanisms will be discussed more fully in 5.3.b. The catalytic nitrosation of amines by thiocyanate is thought to be of principal significance for smokers because thiocyanate levels in the saliva of smokers is higher than for nonsmokers (Butts, et al., 1974). This is due to the detoxification of HCN which is present in cigarette smoke.

Wetherhold, et al. (1960) have studied the physiological effects of exposure to chemicals which produce cyanosis at high doses. They suggest that chronic exposure to low levels of these chemicals may result in prolonged hemoglobin deficiency or anemia. Nitrogenous species in this category include HCN,  $\text{N}_2\text{O}_3$ , nitrates, and aromatic amino and nitro compounds.

Studies on the biological response to cigarette smoke have shown a relationship between HCN levels and changes in pulmonary function. Rylander (1973) found that HCN concentrations in cigarette smoke had a high correlation to the decrease in the number of free lung cells (macrophages and leukocytes) in guinea pigs exposed to the smoke from 5 cigarettes. Albert, et al. (1974) found that HCN exposure could accelerate mucociliary clearance from the distal bronchii of donkeys exposed to both cigarette smoke and HCN.

The toxicity of HCN has been widely studied, even on human subjects. Table 2-2 lists the findings of these investigations. One interesting discovery is that, inexplicably, dogs were the most susceptible species investigated. It is possible that some animal species are even more sensitive. In man, a breakpoint in the body's ability to detoxify cyanide seems to exist for concentrations of about 100 ppm. Exposure to concentrations lower than this may lead to chronic intoxication. Exposure to 18 to 36 ppm for an unspecified number of hours was noted to produce slight symptoms. This result was used to set the Threshold Limit Value (TLV) of 10 ppm HCN for an industrial exposure of healthy white males for 8 hours a day, 5 days a week. Equation 2-1 may be used in conjunction with the American TLV to yield an Estimated Permissible Level of 0.0165 ppm. No ambient HCN measurements have been undertaken.

b. Nitriles

The organic cyanides (nitriles) other than HCN which have been at least tentatively identified in the exhaust of combustion systems are methyl cyanide, ethyl cyanide, vinyl cyanide, cyanogen, glycolonitrile, phenyl cyanide, and valeronitrile. Of these, no inhalation exposure data are available for phenyl cyanide or valeronitrile. In fact, there is little data on chronic exposure to any of the cyanides other than HCN.

The cyanides attack the body in much the same manner as HCN, since it is the  $CN^-$  ion which attacks enzymes that are vital to respiratory function (Wolfsie and Shaffer, 1959). The data on acute exposure to the cyanides indicates that, like HCN, they attack the respiratory,

TABLE 2-2  
The Acute Toxicity of HCN

<u>Species</u>	<u>Concentration/Exposure</u>	<u>Effect</u>	<u>Reference</u>
Rat	544 ppm/5 min 110 ppm/1.5 hrs	LC <sub>50</sub> lethal	Moore and Gates, 1946 Dudley et al., 1942
Mouse	1300 ppm/1-2 min 169 ppm/30 min 110 ppm/45 min 45 ppm/2.5-4 hrs 40 ppm/7 hrs	lethal LC <sub>50</sub> lethal lethal lethal	Sterner, 1949; Flury & Zernik, 1931 Moore and Gates, 1946 Sterner, 1949; Flury & Zernik, 1931 Sterner, 1949; Flury & Zernik, 1931 Sterner, 1949; Flury & Zernik, 1931
Rabbit	498 ppm/2 min 315 ppm/until death 120 ppm/ ?	LC <sub>10</sub> lethal no symptoms	Christensen & Luginbyhl, 1975 Dudley et al., 1942 Dudley et al., 1942
Cat	2074 ppm/ ? 315 ppm/until death  125 ppm 180 ppm	LC* <sub>10</sub> respiratory paralysis in 2 min. death in 5-10 minutes toxic in 6-7 minutes lethal	Christensen & Luginbyhl, 1975 Dudley et al., 1942  Dudley et al., 1942 Sterner, 1949; Flury & Zernik, 1931
Guinea Pig	315 ppm/until death 200 ppm/1.5 hrs	lethal no symptoms	Dudley et al., 1942 Dudley et al., 1942
Monkey	125 ppm	toxic in 12 minutes	Dudley et al., 1942
Dog	300 ppm/3 min 115 ppm/until death 90 ppm/until death  35-65 ppm  30 ppm	LC <sub>50</sub> lethal tolerated for hours, eventual death vomiting convulsions, recovery or possible death may be tolerated	Moore and Gates, 1946 Dudley et al., 1942 Dudley et al., 1942  Dudley et al., 1942  Dudley et al., 1942

\* the "lowest lethal concentration which has been published" according to Christensen and Luginbyhl, 1975

0000490129166

TABLE 2-2  
(continued)

<u>Species</u>	<u>Concentration/Exposure</u>	<u>Effect</u>	<u>Reference</u>
Human	100 ppm/1 hr	LC* <sub>10</sub>	Christensen and Luginbyhl, 1975
	270 ppm	immediately lethal	Flury & Zernik, 1931; Kobert, 1912
	266 ppm/10 min	lethal	Prentiss, 1951
	200 ppm/30 min	lethal	Prentiss, 1951
	181 ppm/10 min	lethal	Flury & Zernik, 1931; Kobert, 1912
	135 ppm/30 min	lethal	"
	110-135 ppm	lethal in .5-1 hour or later or dangerous to life	"
	45-54 ppm/.5-1 hr	no effects	"
	18-36 ppm/"hours"	slight symptoms after exposure for several hours	"
	27 ppm/10 min	irritant	Prentiss, 1951

---

\*the "lowest lethal concentration which has been published" according to Christensen and Luginbyhl, 1975

cardiovascular, and central nervous systems. Cyanogen is approximately as toxic as HCN and the other nitriles are slightly less toxic.

Because the response to acute exposure of HCN and the other cyanides is similar, the assumption that the effect due to chronic exposure is also similar is justified. The limited toxicological information which is available on the nitriles will be presented in the following paragraphs. No ambient measurements of these species have been made.

An accident which exposed a group of subjects to high concentrations of methyl cyanide (acetonitrile,  $\text{CH}_3\text{CN}$ ) led to several cases of severe illness and one death. However, these results were attributed to secondary thiocyanate poisoning rather than cyanide poisoning (Grabois, 1955). This emphasizes the fact that thiocyanate poisoning itself can be very severe. An early study of methyl cyanide determined that a lethal exposure for rats is 8000 ppm for a duration of 4 hours (Carpenter, et al., 1949). However, susceptibility to methyl cyanide varies widely among different animal species and even from one human individual to another. This was demonstrated by Pozzani, et al. (1959) in animal and human studies. Three human subjects were exposed to 40 ppm, two to 80 ppm, and two to 160 ppm for 4 hours. There was no detectable blood cyanide and urinary thiocyanate levels were inconsistent. One subject who was exposed to 40 ppm and one of those exposed to 160 ppm experienced bronchial tightness commencing several hours after the termination of exposure. This data lead to the adoption of a TLV for methyl cyanide of 40 ppm which infers an estimated permissible level of 0.066 ppm for continuous exposure of the general populace. Olishifski and McElroy (1971) report that methyl cyanide can be smelled at this concentration.

Little toxicological data exist for ethyl cyanide (propionitrile,  $\text{CH}_3\text{CH}_2\text{CN}$ ). A lethal exposure for rats has been shown to be 500 ppm for 4 hours (Smyth, et al., 1951). No TLV or  $\text{CD}_{50}$  exists. Patty (1949) suggests a TLV of 20 ppm which yields an EPL of 0.033 ppm.

Table 2-3 lists the effects of acute exposure of animals to vinyl cyanide (acrylonitrile,  $\text{CH}_2\text{CHCN}$ ). Dudley and Neal (1942) exposed various animals to vinyl cyanide for 4 hours in an effort to find the  $\text{LC}_{10\text{W}}$ , or lowest lethal concentration. As for HCN, dogs seem to be the most susceptible species, one dog dying at an exposure of 55 ppm. Rats could endure up to 635 ppm/4 hours without fatality. A second paper (Dudley, et al., 1942) investigated the effect of chronic exposure. Two dogs and four monkeys were exposed to 56 ppm for 4 hours per day, 5 days a week for four weeks. The monkeys exhibited no toxic symptoms but one dog died four hours after the first exposure and the second developed a transitory paralysis. Sixteen rats, sixteen guinea pigs, three rabbits, and four cats were then exposed to 100 ppm 4 hours per day, 5 days a week for eight weeks. All exhibited lethargy and one of the cats died. In the final set of experiments, sixteen rats, sixteen guinea pigs, four rabbits, four cats, and two monkeys were exposed to 153 ppm for 4 hours per day, 5 days a week for eight weeks. This dose was toxic to all species, especially monkeys and cats. Irritation of eyes and nose, loss of appetite, gastrointestinal complaints, and an incapacitating weakness in the hind legs were noted. However, they concluded that no evidence of cumulative action was observed. This conclusion is questionable since the major toxic symptoms were evidenced either at the very beginning or near the end of the exposure period. Exposure of humans to vinyl cyanide causes flushing

TABLE 2-3  
The Acute Toxicity of Vinyl Cyanide (Dudley and Neal, 1942)

<u>Species</u>	<u>Concentration/ Exposure (ppm/hours)</u>	<u>% Deaths</u>	<u>Effect</u>
Rat	2445/1	81	Deaths in 4 hrs. Slight effects to 24 hours.
	2445/½	0	Marked. Slight residual effects to 24 hours.
	1490/1	25	Deaths in 4 hours. Slight effects to 24 hours
	1490/½	0	Marked. No residual effects after 24 hours
	1260/2	100	Dead in 4 hours
	1270/1	0	Marked. Normal in 48 hours
	1270/½	0	Marked. No residual effects after 24 hours
	665/1	0	Marked, transitory.
	665/½	0	Moderate
	635/4	100	Dead in 4 hours
	595/2	6	Marked, transitory
	320/8	94	Fatal
	315/4	31	Marked. No effects in 24 hours
	305/2	0	Slight, transitory
	270/8	44	Marked. No effects in 24 hours
	210/8	6	Marked, transitory
	135/8	0	Moderate, transitory
	130/4	0	Slight, transitory
	90/8	0	Slight discomfort
Guinea Pig	1160/4	100	Fatal in 1½-18 hours
	575/4	63	Eye and nose irritation Fatal in 3-6 days.
	265/2	0	Slight, transitory
	100/4	0	Slight, transitory

TABLE 2-3  
(continued)

<u>Species</u>	<u>Concentration/ Exposure (ppm/hours)</u>	<u>% Deaths</u>	<u>Effect</u>
Rabbit	580/4	100	Fatal in 3-4 hours
	260/4	100	Fatal in 4-5 hours
	135/4	0	Marked, transitory
	100/4	0	Slight, transitory
Cat	600/4	100	Death in 1½ hours
	275/4	0	Marked. No effect in 24 hours
	100/4	0	Slight, transitory.

of the face and increased salivation. Prolonged exposure leads to eye and nasal irritation, photophobia, and deepened respiration. More severe exposures cause nausea, shallow respiration, vomiting, asthenia, dyspnea, and sometimes headaches and diarrhea (Fairhall, 1969). Jaundice (Wilson, 1944) and dermatitis (Schwartz, 1945) have been reported to result from chronic exposure. Serum thiocyanate levels increase immediately following exposure and the urine thiocyanate level increases 24 to 48 hours after exposure (Lawton, et al., 1943). Like HCN, vinyl cyanide can be readily absorbed through the skin. The TLV of 20 ppm yields an estimated permissible concentration of 0.033 ppm.

Cyanogen (oxalonitrile,  $C_2N_2$ ) is an irritant gas. Table 2-4 lists the effects of inhalation exposure on man and animals to  $C_2N_2$ . A comparison of Table 2-4 with Table 2-1 indicates that cyanogen is at least as toxic as hydrogen cyanide. The lowest lethal concentration of HCN for exposure of cats is 180 ppm while for  $C_2N_2$  it is 90 ppm. For rabbits, the  $LC_{10w}$  for  $C_2N_2$  is 395 ppm for an unspecified duration and for HCN it is 498 ppm for 2 minutes or 315 ppm for an unspecified duration. Unfortunately, the length of exposure is an important parameter in comparing the toxicity of these two cyanides. An  $LC_{50}$  for rats for HCN is 544 ppm/5 minutes and for  $C_2N_2$  it is 350 ppm/1 hour but the difference in duration of exposure may affect this last result. In fact, examination of the data collected by McNerney and Schrenk (1960) indicates that an  $LC_{50}$  for rats for a 5 minute exposure to  $C_2N_2$  would exceed 3000 ppm. Therefore, it seems that rats metabolize  $C_2N_2$  much less effectively than HCN. On the other hand, the lowest toxic concentration for human exposure to  $C_2N_2$  is slightly

TABLE 2-4  
The Acute Toxicity of Cyanogen, C<sub>2</sub>N<sub>2</sub>

<u>Species</u>	<u>Exposure</u>	<u>Effect</u>	<u>Reference</u>
Human	16 ppm/ ?	TD <sub>low</sub> (irritant)	McNerney & Schrenck (1960)
Rat	350 ppm/1 hr	LC <sub>50</sub>	" (1960)
Mouse	345 ppm/ ?	LC <sub>low</sub>	National Defense Research Committee (1942)
Cat	98 ppm/ ?	LC <sub>low</sub>	Flury & Zernik (1931)
Rabbit	395 ppm/ ?	LC <sub>low</sub>	"

lower than that for HCN. Exposure to 18-36 ppm of HCN for several hours was slightly toxic and a 10 minute exposure to 27 ppm resulted in irritation. Cyanogen at 16 ppm immediately caused eye irritation in all subjects and nasal irritation in most subjects almost immediately. A TLV has not been set for  $C_2N_2$  but the data indicate that it should be approximately the same as that for HCN, and the 1968 American Conference of Governmental Industrial Hygienists has tentatively suggested a TLV of 10 ppm. Therefore, an estimated permissible level for continuous exposure to  $C_2N_2$  would be 0.0165 ppm.

The sole toxicological study of glycolonitrile,  $HOCH_2CN$ , found that 8 hours was the maximum period for which exposure of rats to very high concentrations did not result in death within two weeks (Smyth, et al., 1962). Furthermore, exposure of six rats to 250 ppm for 4 hours resulted in four deaths. The toxicological data is insufficient to allow determination of a TLV,  $LD_{50}$  or safe level for continuous exposure to glycolonitrile.

### 2.3 The Amines

Organic derivatives of ammonia are classified as primary, secondary or tertiary amines, depending upon the number of hydrogen atoms that have been substituted for by hydrocarbon radicals. Ammonia is the amine which is most often identified in combustion emissions. This is partially due to the common use of ion electrodes as an analytical technique and the widespread interpretation of the total amine measurement as ammonia. Nevertheless, because  $NH_3$  seems to have the greatest number of combustion sources, it will be discussed first and in greatest detail. Because nitrosamines are carcinogens, they

may be thought of as presenting the greatest hazard to the public health. For this reason, they will be discussed just after  $\text{NH}_3$ . The alkylamines are the only other amines which have been identified as combustion products. They will be discussed at the end of this section.

a. Ammonia ( $\text{NH}_3$ )

Ammonia can be smelled at levels as low as 1 ppm (Smyth, 1956; Patty, 1949) although the odor threshold is often cited as 20 ppm (Braker and Mussman, 1971). Because it is soluble it is normally absorbed by the mucous membranes and attacks the upper respiratory tract. However, high concentrations may penetrate deeper and irritate the alveolar surfaces. It is a severe nasal and eye irritant and has been known to cause temporary blindness. Epidermal contact with a mixture of liquid  $\text{NH}_3$  and oil has been associated with cancer in humans (Shimkin et al., 1954). The following paragraphs will discuss the adverse effects of  $\text{NH}_3$ .

Perturbations in the concentrations of trace species and the greenhouse effect was discussed in detail in section 5.1.c in connection with  $\text{N}_2\text{O}$ . Ammonia can also exert an influence on the energy balance of the earth because it has a strong infrared band centered at  $10.53 \mu\text{m}$ . The major sinks of  $\text{NH}_3$  are attack by hydroxyl radicals, photodissociation, and washout by rain. The atmospheric lifetime of  $\text{NH}_3$  is estimated to be about 10 days. Wang, et al. (1976) state that atmospheric levels of  $\text{NH}_3$  could possibly double by the year 2020. They calculate that this could result in a  $0.12^\circ\text{K}$  rise in the global average temperature. This increase is even more significant if  $\text{N}_2\text{O}$  and  $\text{HNO}_3$  levels also double (see 2.1.c).

Exposure to high concentrations of  $\text{NH}_3$  can lead to conjunctivitis, laryngitis, tracheitis, immediate pain and choking, temporary reflex arrest of breathing, reduced heart beat rate, and bronchoconstriction. Fatal edema of the glottis may be a result. Non-fatal cases may result in respiratory infections, asthma, chronic bronchitis, and dilation of the heart. In rare cases, emphysema and pulmonary fibrosis may develop. Exposure to lower concentrations will result in irritation of the mucous membranes and the consequent rhinitis (nose bleed), pharyngitis, and bronchitis (Gleason, et al., 1963). Because it is a strong irritant, it immediately effects the conjunctiva and the cornea.

Table 2-5 lists the lethal concentrations of  $\text{NH}_3$  for exposure of man and animals. Comparisons of these levels with fatal doses of NO and HCN reveals that  $\text{NH}_3$  is not nearly as acutely toxic as some of the other nitrogenous species.

Boyd, et al. (1944) exposed rabbits and cats to an average of 10,000 ppm for one hour, a dose which was found to be an approximate  $\text{LD}_{50}$ . They noted an increase in respiratory tract fluid output, an increase in plasma lipids, and an increase in hemoglobin which began about 24 hours after exposure. In the initial stages of gassing, the animals exhibited symptoms of central nervous system involvement marked by excitement but toward the end of gassing a curare-like paralysis was exhibited. CNS involvement has also been noted in connection with accidental exposure of humans, but this effect has not been satisfactorily explained since  $\text{NH}_3$  is not considered to act directly on the nervous system (Fairhall,

TABLE 2-5  
The Acute Toxicity of Ammonia, NH<sub>3</sub>

<u>Species</u>	<u>Exposure</u>	<u>Effect</u>	<u>Reference</u>
Human	10000 ppm/3 hrs	LC <sub>10w</sub>	Christensen and Luginbyhl (1975) Braker and Mossman (1971)
	5000 ppm/ ?	Serious edema, strangulation, asphyxia, fatal almost immediately.	
	1700 ppm/ ?	Serious coughing, bronchial spasms, less than a half hour of exposure may be fatal.	"
	700 ppm/ ?	Severe eye irritation. No permanent effect for exposures less than ½ hr.	"
	400 ppm/ ?	Severe irritation of the throat, nasal passages, and upper respiratory tract.	"
	100 ppm/ few minutes	Noticeable irritation of the eyes and upper respiratory tract.	"
	40 ppm/ ?	Possible slight eye irritation.	"
	20 ppm/ ?	First noticeable odor	"
	20 ppm/ ?	TC <sub>10w</sub> irritant.	Vigliani and Zurco (1955)
Rat	2000 ppm/4 hrs	LC <sub>10w</sub>	Carpenter et al.(1949)
Mouse	4837 ppm/1 hr	LC <sub>50</sub>	Christensen and Luginbyhl (1975) Boyd et al. (1944)
Cat	10,066 ppm/1 hr	LC <sub>50</sub>	
Rabbit	10,066 ppm/1 hr	LC <sub>50</sub>	"

1969). Vigliani and Zurlo (1956) found that irritation and discomfort resulted from human exposure to 20 ppm. Dalhamn (1956) found that exposure to 3 ppm resulted in the cessation of respiratory cilia beating in rats. The cilia are one of the major respiratory clearance mechanisms and loss of the cilia activity can be expected to result in increased incidence of respiratory tract diseases and infections.

Apparently, the only study of chronic exposure to  $\text{NH}_3$  was conducted by Weatherby (1952). He exposed animals to 170 ppm for 18 weeks, 6 hours per day, 5 days per week. Surprisingly, the animals did not exhibit respiratory tract complications or CNS involvement but rather, minor changes in the spleen, kidneys, adrenals, and liver. This indicates that the physiological response to chronic exposure may involve more biological systems than does acute exposure to  $\text{NH}_3$ .

The calculated permissible level for continuous exposure to  $\text{NH}_3$  is 0.0825 ppm\*. Rodale (1964) reports that Los Angeles and Charleston have recorded levels as high as 0.2 ppm but does not reveal his source for this information. Jacobs (1960) also states that  $\text{NH}_3$  concentrations in urban communities may reach 0.2 ppm with average concentrations of 0.02 ppm. Pitts (1977) reports levels ranging from 0.005 to 0.040 in urban smog. The ambient concentration is about 0.006 ppm.

#### b. Nitrosamines

Cancer is the third leading cause of mortality in the United States. Anthropogenic environmental agents are estimated as causing

---

\*Based on a TLV of 50 ppm, a value which is currently being reconsidered.

between 60 and 90% of these cancers (Federation of American Scientists, 1976; Train, 1977). Of the various environmental carcinogens, the most potent are the nitrosamines and other N-nitroso compounds. The World Health Organization (Bogovski, 1973) recognizes the N-nitroso compounds as the most powerful carcinogens yet tested against experimental animals. The EPA (1974) states that the nitrosamines have no equals as a family of carcinogens. As previously discussed, it has recently been shown that nitrosamines and nitrosamine precursors can be emitted from combustion systems. If this is the case, then it may not be imprudent to conjecture that, dependent upon emission levels, the nitrosamines may be the most important pollutants associated with combustion. While it is true that other carcinogens, notably benzo(a)pyrene and 3-nitro-3-hexene (see section 5.4, nitro-olefins) have been identified in emissions from combustion systems, none are as powerful as nitrosamines and their sources may not be as numerous or widespread. However, epidemiological studies have not yet shown a direct relationship between exposure to nitroso compounds and human cancer. But, as the EPA (1977) states, "there is no reason to assume that the human species should be immune in view of the available data from animal studies." The EPA goes on to list six reasons why nitrosamines should be considered a public health hazard:

- (1) all mammals studied have been shown to be susceptible to tumor induction by at least one nitrosamine;
- (2) nitrosamines (or their metabolites) are highly effective carcinogens by any route of administration--inhalation and oral intake included;

- (3) some of the animal neoplasms induced by nitrosamines are predominantly epithelial and their organotypic and histologic features resemble those seen in humans;
- (4) nitrosamines are metabolized in vitro similarly by human, guinea pig, and rat tissue;
- (5) nitrosamines occur in the human environment--cured meat and fish products, tobacco and tobacco smoke, and ambient air; and
- (6) evidence is conclusive that nitrosamines or nitrosamides can be formed in vivo, most likely in the mammalian stomach or possibly in the lower gastrointestinal tract, through interaction of secondary and tertiary amines ingested as food or drugs with nitrite and as a result of microbial metabolism.

Table 2-6 lists the nitrosamine concentrations which have been measured in the ambient air. The high concentrations measured in Baltimore are attributable to emissions of dimethylhydrazine (which contained traces of dimethylnitrosamine) from a Food Machinery and Chemical Corporation (FMC) plant. Nitrosamines can also be formed in urban atmospheres from precursors such as NO, NO<sub>2</sub>, HNO<sub>2</sub>, N<sub>2</sub>O<sub>3</sub>, and anthropogenic or naturally occurring secondary amines. An example of this process was reported by Bretschneider and Matz (1974) who measured dimethylnitrosamine and diethylnitrosamine in chemical plants which produced dimethylamine and diethylamine. At present it is impossible to determine the relative importance of natural and anthropogenic sources.

Organic nitroso compounds are produced when a nitrosyl radical (-N=O) is attached to an organic molecule through a nitrogen atom or a carbon atom, yielding N-nitroso and C-nitroso compounds respectively. C-nitroso compounds are of little interest and will not be discussed

TABLE 2-6

## Measurements of Nitrosamine Concentrations in Ambient Air\*

Location	Approx. hours of sampling	Concentration range, $\mu\text{g}/\text{m}^3$ (1 to 2 hr. peaks)		
		DMN	Unknown 1 <sup>a</sup>	Unknown 2 <sup>a</sup>
Baltimore, Md., area				
FMC property	54	1 to 36 ( $\sim$ .219-7.898 ppb)	ND <sup>b</sup> to 0.08	ND <sup>b</sup> to 2.7
Within 0.6 km radius of FMC property	27	0.03 to 7.6 ( $\sim$ .007-1.66 ppb)	ND <sup>b</sup> to 0.17	0.02 to 0.32
Within 0.6 - 1 km radius of FMC property	30	Trace <sup>c</sup> to 2.0 ( $\sim$ .439 ppb)	ND <sup>b</sup> to 0.03	ND <sup>b</sup> to 0.34
Outside 2 km radius of FMC property	14	0.02 to 0.13 ( $\sim$ .004-.029 ppb)	0.02 to 0.04	ND <sup>b</sup> to 0.3
Belle, W. Va.	78	ND <sup>b</sup> to 0.98 ( $\sim$ .215 ppb)	ND <sup>b</sup> to 0.06	ND <sup>b</sup> to 0.08
So. Charleston and Charleston, W. Va.	30	ND <sup>b</sup> to 0.06 ( $\sim$ .013 ppb)	--	--
Nitro, W. Va.	5	ND <sup>b</sup>	--	--
Northern New Jersey	11	ND <sup>b</sup>	--	--
Philadelphia, Pa. <sup>d</sup>	12	ND <sup>e</sup>	ND <sup>b</sup>	ND <sup>b</sup>
Wilmington, Del. <sup>d</sup>	12	ND <sup>e</sup>	ND <sup>b</sup>	ND <sup>b</sup>
Waltham, Mass. <sup>d</sup>	4	ND <sup>e</sup>	ND <sup>b</sup>	ND <sup>b</sup>
New York, N.Y.	10	ND <sup>b</sup> to 0.016 ( $\sim$ .004 ppb)	--	--
Denver, Colo. (Eisenhower Tunnel)	1	Trace	--	--
Los Angeles, Cal.	1	ND <sup>e</sup>	--	--
St. Louis, Mo.	1	ND <sup>e</sup>	--	--

\*from EPA (1977); <sup>a</sup>Unknowns were analyzed only by the TEA technique. Total sampling time for unknowns in Baltimore, Md. was about half that for DMN and in Belle, W. Va., was about one-third that for DMN. <sup>b</sup>ND = not detectable ( $< 0.0002 \mu\text{g}/\text{m}^3$ ); <sup>c</sup>Trace is defined as a detectable but nonquantifiable amount  $< 0.0002 \mu\text{g}/\text{m}^3$ ; <sup>d</sup>Sampled during initial TEA study only; <sup>e</sup>ND = not detectable ( $< 0.1 \mu\text{g}/\text{m}^3$ ).

further. In turn, the N-nitroso compounds may be categorized as either N-nitrosamines or N-nitrosamides. Because there is no evidence that N-nitrosamides or their precursors are emitted from combustion systems, they will not be discussed further. The properties of the nitrosamines are contained in Volume I of the IARC Monographs on the Evaluation of the Carcinogenic Risk of Chemicals to Man (1972).

With the exception of one tertiary amine (aminopyrene), only secondary amines nitrosate to form nitrosamines.\* Dimethylamine is the only secondary amine identified in the exhaust from combustion systems. This is one of the reasons that its nitrosation product, dimethylnitrosamine (DMN), is the focus of much of this section. A second reason is that much of the current nitrosamine research involves DMN because it is one of the easiest nitrosamines to detect and quantify. Finally, the EPA (1977) reports that the acutely toxic dose and the dose required to induce tumors increase with increasing length of the carbon chain of the alkyl group. Therefore, dimethylnitrosamine is one of the more powerful nitrosamines. For example, the LD<sub>50</sub> for a single oral dose to an adult male rat is 27-41 mg/kg of body weight for DMN and 1200 mg/kg for dibutylnitrosamine. These three factors combine to justify the attention devoted to DMN in the remainder of this section.

There is limited information on the atmospheric chemistry of the nitrosamines. Gas phase nitrosamines are not known to degrade thermally in the atmosphere, even in the presence of acidic aerosols. However,

---

\*Trimethylamine may react to form dimethylnitrosamine in a multi-step process which is atypical of nitrosamine formation processes (Scanlan, et al., 1974; Fiddler, et al., 1972).

they do decompose photolytically under ultraviolet and visible light. As evidenced by the data presented in Table 2-6 this photolytic dissociation is not active enough to remove completely nitrosamines from the atmosphere but it is believed that nitrosamine concentrations may be higher at night. Nitrosamines may be formed in the atmosphere through both homogeneous and heterogeneous reactions. The relative importance of these two reaction paths is as yet unknown. Nuerath, et al. (1965) demonstrated that secondary amines ( $R_2NH$ ) could react with NO and  $NO_2$  to form nitrosamines ( $R_2NNO$ ) through the reaction:

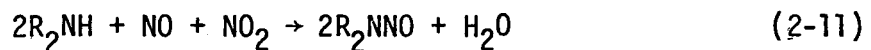

This reaction is catalyzed by the presence of nitrous acid,  $HNO_2$ , which may be formed in the atmosphere through reactions such as:



Hanst, et al. (1976) observed DMN formation at an amine disappearance rate of 4%/min in humid atmospheres containing 0.5 ppm of  $HNO_2$ , 2 ppm NO, 2 ppm  $NO_2$ , and 1 ppm of  $(CH_3)_2NH$ . The formation rate decreased by a factor of 4 in the absence of  $HNO_2$  and water vapor. A night time mixture of 0.18 ppm NO, 0.02 ppm  $NO_2$ , and 20,000 ppm  $H_2O$  would produce 0.01 ppm of  $HNO_2$  at equilibrium. They calculate that dimethylamine could nitrosate at about 6%/hr. After sunrise, the accumulated DMN would disappear at approximately 50%/hr. EPA (1977) calculations indicate that the formation rate derived by Hanst and coworkers may be high. However, gas phase formation can be supplemented by heterogeneous reactions involving atmospheric particulates, especially

nitrites and nitrates. Assuming that optimum pH conditions exist on the surface of aerosols, the dimethylamine nitrosation rate in %/hr can be calculated from:

$$\frac{d(\text{CH}_3)_2\text{NH}}{dt} = k_{13}[\text{NITRITE}]^2 \quad (2-13)$$

where the nitrite concentration is taken on the particle surface. Unfortunately, ambient nitrite levels are uncertain but it is known that urban aerosols contain significant nitrite concentrations. In summary, nitrosamines may be formed in the ambient atmosphere through heterogeneous and homogeneous reactions. Precursors include the amines, particulates, nitrite, nitrate, NO, NO<sub>2</sub>, N<sub>2</sub>O<sub>3</sub>, HNO<sub>2</sub> and possibly other species. The most significant removal process is photolytic dissociation.

Nitrosamines can also be formed in vivo from these same precursors although sources of the precursors and reaction catalysts may differ. In general, the reaction path is as follows:

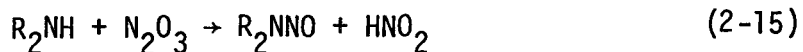

The nitrosamine formation rate can be calculated either through equation (2-16) or (2-17):

$$\frac{d[(\text{CH}_3)_2\text{NNO}]}{dt} = k_{16}[\text{R}_2\text{NH}][\text{HNO}_2]^2 \quad (2-16)$$

$$\frac{d[(\text{CH}_3)_2\text{NNO}]}{dt} = k_{17}[\text{TOTAL AMINE}][\text{TOTAL NITRITE}]^2 \quad (2-17)$$

where "total amine" refers to ionized and nonionized amines. The concentrations of  $R_2NH$  and  $HNO_2$  and the rate coefficient  $k_{17}$  vary with pH, with  $k_{17}$  showing a maximum at a pH of 3.4. It should be noted that  $k_{17}$  for dimethylamine nitrosation is slower than  $k_{17}$  for any other secondary or tertiary amine except piperidine (Mirvish, 1970; EPA, 1977). However, many chemical substances can catalyze the nitrosation reactions, especially thiocyanate. In this case, the reaction proceeds via the steps:

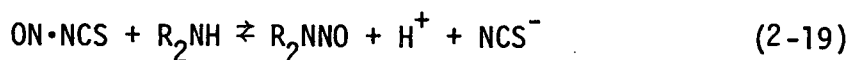
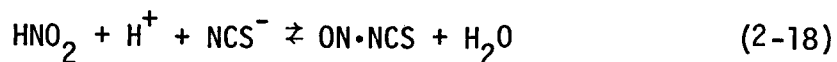

as

$$\frac{d[R_2NNO]}{dt} = k_{20}[R_2NH][HNO_2][H^+][NCS^-] \quad (2-20)$$

or as

$$\frac{d[R_2NNO]}{dt} = k_{21}[\text{amine}][HNO_2][NCS^-] \quad (2-21)$$

This thiocyanate catalyzed nitrosation process can compete favorably with the  $N_2O_3$  mechanism (2-16 and 2-17) at  $pH < 2.5$ , or in the presence of high concentrations of thiocyanate or other catalysts, or at low nitrite concentrations. Other catalysts which have been studied are sulfates, phosphates, halides, and formaldehyde (Keefer and Roller, 1973; Mirvish, 1971). Chemicals which have been shown to inhibit nitrosation are tannins, sulphydryl compounds, ascorbic acid, and glutathione (Bogovski et al., 1972; Sen and Donaldson, 1973; Dahn, et al., 1960).

In vivo formation may occur 1) in the gastrointestinal tract, where the acidity promotes nitrosamine formation reactions, 2) in the

mouth and nasopharyngeal cavity where thiocyanate may catalyze the reactions (the saliva of smokers contains about 6 mM  $\text{NCS}^-$ , compared to gastric fluid which has 0.2 - 0.7 mM  $\text{NCS}^-$ ), or 3) in the pulmonary system, where particulates of a diameter of approximately 0.1  $\mu\text{m}$  may have significantly long residence times. In vivo formation is, therefore, a complex process, but may be a significant source of exposure.

Before the carcinogenic properties of dimethylnitrosamine became known, a toxicological study by Jacobson, et al. (1955) revealed that it is powerful systemic toxin. Table 2-7 reveals the mortality rates of rats, mice, and dogs exposed to DMN a single time for 4 hours. The  $\text{LC}_{50}$  for rats was determined to be 78 ppm, for mice it was 57 ppm, and for dogs it was less than 16 ppm. Within the first few hours during and after exposure, the symptoms included gastrointestinal irritation, nausea, vomiting, diarrhea, increase in body temperature, a transient leukopenia and failure of the blood coagulation mechanism. There were hemorrhages into the wall of the gastrointestinal tract, the abdominal cavity, and other tissues. The greatest damage was done to the liver, and this is assigned primary responsibility for production of a diseased state and death. Humans accidentally exposed to DMN also showed evidence of abnormal liver function, elevated temperature and malaise (Freund, 1937; Barnes and Magee, 1954; Jacobsen et al., 1955). More recent animal experiments have confirmed the hepatotoxic nature of DMN (McLean et al., 1965; Carter et al., 1969; Terracini et al., 1967). Therefore even if DMN were not carcinogenic it might be a significant health hazard near sources.

The carcinogenic properties of DMN were discovered by Magee and Barnes (1956) in research conducted on rats. Besides liver tumors,

TABLE 2-7

## The Acute Toxicity of Dimethylnitrosamine\*

<u>Species</u>	<u>Exposure</u>	<u>Mortality</u>	<u>Group Mortality at 14 days</u>
Rats	188 ppm/4 hrs	1/10 1st day, 8/10 2nd day, 10/10 3rd day	100 %
	151 ppm/4 hrs	9/10 2nd day, 10/10 4th day	100
	103 ppm/4 hrs	1/10 2nd day, 5/10 3rd day, 6/10 6th day, 7/10 7th day	70
	77 ppm/4 hrs	2/10 3rd day, 4/10 4th day, 5/10 5th day	50
	67 ppm/4 hrs	2/10 3rd day, 3/10 4th day, 4/10 6th day	40
	51 ppm/4 hrs	1/10 3rd day	10
	41 ppm/4 hrs	0/10 14th day	0
Mice	67 ppm/4 hrs	7/10 4th day	70
	60 ppm/4 hrs	2/10 1st day, 8/10 2nd day, 9/10 3rd day	90
	55 ppm/4 hrs	3/10 4th day	30
	51 ppm/4 hrs	2/10 2nd day	20
	39 ppm/4 hrs	1/10 1st day	10
Dogs	144 ppm/4 hrs	3/3 1st day	100
	73 ppm/4 hrs	3/3 1st day	100
	43 ppm/4 hrs	2/3 1st day, 3/3 3rd day	100
	16 ppm/4 hrs	2/3 2nd day	67

---

\*from Jacobson et al. (1955)

DMN has produced tumors of the nasal sinus (Druckery et al, 1964), kidney (Magee and Barnes, 1959), and lung (Magee and Barnes, 1967). Nitrosamines have been shown to produce tumors in rats, mice, hamsters, rabbits, guinea pigs, dogs, monkeys, and fish. Cancer has been produced through oral administration, inhalation, subcutaneous injection, and dermal contact. The lowest dose of any nitrosamine shown to cause cancer was reported by Druckery et al. (1967) who fed rats 0.075 mg of DMN per kg of body weight per day for 600 days. Moiseyev and Benemanskii (1975) exposed mice and rats to 0.2 mg/m<sup>3</sup> (~44 ppb) and 0.005 mg/m<sup>3</sup> (~1 ppb) of DMN for 17 months. Eighty-two percent of the rats exposed to the higher dose developed tumors. Only 29% of the control group developed tumors. The group exposed to 1 ppb did not evidence an excess tumor rate. The EPA (1977) reports two studies of DMN exposure by Thomas. In the first investigation, rats, mice, hamsters, and dogs were exposed to 6 ppb of DMN (plus 5 ppm of unsymmetrical dimethylhydrazine, UMDH) for six months. Slight-to-moderate hepatotoxic symptoms were noted in the dogs and no overt symptoms were observed in the other animals. Similar exposure to 0.6 ppb of DMN + 0.5 ppm of UMDH did not result in any overt symptoms of toxicity. In the second investigation, Thomas fed mice oral doses of DMN. The oral doses were calculated as equivalents of inhalation doses for 6 hour daily exposures. The results of the post-mortem histological examinations are listed in Table 2-8. Vacuolization of hepatocytes in controls was thought to result from anesthesia prior to sacrifice. Exposure levels as low as 5 and 10 ppb for 5 days/week for 2 months resulted in an increased incidence of liver damage. These various investigations into the carcinogenic activity of dimethyl-

TABLE 2-8  
Histopathology of Liver Tissue  
from Mice Exposed to Dimethylnitrosamine\*

Oral dose, $\mu\text{g}/\text{kg}$	Inhalation equivalent (6-hr), ppb	Hepatic response	No. animals with response/total no. animals	Percent of animals with response
0	0	Vacuolization	40/61	65
5	5	Vacuolization	48/61	78
10	10	Vacuolization	53/59	90
50	50	Vacuolization	38/38	100
500	500	Vacuolization	33/36	91
1000	1000	Vacuolization	35/36	97
5000	5000	Vacuolization and multifocal hepatic necrosis	35/36 34/36	97 94

\* from Thomas as reported by the EPA (1977)

nitrosamine indicate that it is a powerful carcinogen which acts primarily on the hepatic system.

Because there is no TLV of  $LD_{50}$  for dimethylnitrosamine, it is not possible to define an Estimated Permissible Level for continuous exposure. General policy has been that no exposure to a carcinogen is safe, but the EPA (1977) indicates that this policy may be changing. However, it has been shown that short term, semicontinuous or continuous exposure to 5 - 20 ppb may result in changes in liver structure in experimental animals. A prudent factor of safety for continuous exposure of susceptible humans would be at least 10, yielding an EPL of 0.5 to 2.0 ppb. As noted in Table 2-6, measurements of DMN in U.S. cities or localities may be as high as 1.7 ppb near a source. It must also be noted that nitrosamine exposure also occurs via drugs, food, water, and smoking, and these doses are essentially additive.

c. The Alkyl Amines

Monomethylamine ( $CH_3NH_2$ ), dimethylamine ( $(CH_3)_2NH$ ), trimethylamine ( $(CH_3)_3N$ ), and ethylamine are the alkyl amines which are gaseous at room temperature and atmospheric pressure. Their toxicological properties are similar and they will be discussed as a group rather than individually.

The odor of the alkylamines is described as fish-like at concentrations lower than 100 ppm and ammoniacal at higher concentrations. Prolonged exposure will result in olfactory fatigue. The alkyl amines are irritant gases and attack the eyes, skin, and upper respiratory tract. Contact with the eyes may lead to lacrymation, conjunctivitis and corneal edema. Prolonged exposure of the skin will result in dermatitis. Concentrations in excess of 100 ppm can irritate the mucous membranes of the

respiratory tract and can result in cough, respiratory distress, bronchitis, tracheitis, pneumonitis, and pulmonary edema (Braker and Mossman, 1971 a, b; Olishifski and McElroy, 1971). The American Conference of Governmental Industrial Hygienists (1971) reports a study of the exposure of rats, guinea pigs, mice, rabbits, and monkeys to either 183 or 97 ppm of dimethylamine for 7 hours daily for 18 to 20 weeks. In addition to many of the previously noted effects, the researchers observed central lobular fatty degeneration and necrosis on the parenchymal cells of the liver in rats, guinea pigs, rabbits and mice. Tubular degeneration of the testes of the monkey and the male rabbit was also observed. Dimethylamine and trimethylamine are precursors of the powerful carcinogen, dimethylnitrosamine (see 2.2.b). For this reason, new sources of these amines should be viewed with caution. However, because there are significant natural sources of secondary amines, it is possible that control of atmospheric nitrosamines is more easily obtained through restrictions of  $\text{NO}_x$ , nitrites, and nitrates, rather than amines.

Threshold Limit Values of 10 ppm are recommended for the alkyl amines. This yields an Estimated Permissible Level for continuous exposure of 0.0165 ppm. Additionally, the Bay Area Air Pollution Control District has established an emissions standard of 0.05 ppm for trimethylamine based on its strong odor.

#### 2.4 Other Nitrogenous Species

A number of the nitrogenous species noted in Chapter 3 and Chapter 4 cannot be classified into any of the three categories previously discussed: oxides of nitrogen, nitriles, and amines. Of these, there is no toxicological information about inhalation exposure

to the species listed in Table 2-9. The others may be classified as nitroparaffins, nitrates, nitro-olefins, and aryl and alkyl nitro compounds.

The nitroparaffins include species such as nitromethane, nitroethane, nitropropane and nitrobutane. Of these, only nitromethane ( $\text{CH}_3\text{NO}_2$ ) has been associated with emissions from combustion systems. Like the other nitroparaffins, it is a moderate irritant, acting on the upper respiratory tract, pulmonary system, and central nervous system. It is considered to be less toxic than nitroethane and nitropropane as far as pulmonary system irritation is concerned, but it has been shown to produce more severe central nervous system involvement. Machle and coworkers (1940) have studied the acute toxicology of the nitroparaffins extensively. Symptoms associated with short term exposure to high concentrations of nitromethane include irritation of the upper respiratory tract, narcosis, and salivation. Continued exposure resulted in weakness, ataxia, incoordination, and pronounced nervousness. Of the two guinea pigs exposed to 1000 ppm for 30 hours, one died. The TLV of 100 ppm yields an EPL of 0.165 ppm, a level which is hardly likely to be exceeded in the ambient environment.

The nitrates of interest are composed of an organic group combined with  $-\text{NO}_3$ . Of particular interest are methyl nitrate,  $\text{CH}_3\text{ONO}_2$ , and neo-pentyl nitrate. Unfortunately, not only is there no specific data on the inhalation exposure to these two nitrates, there is no sound data on the toxicology of airborne nitrates at all. However, it is known that nitrates are precursors of a family of known carcinogens, the nitrosamines. Nitrate emissions should, therefore, be regarded with caution.

TABLE 2-9

Nitrogenous Species for Which there are  
No Toxicological Data

Valeronitrile

Imidazole

Pyrazole

2-Ethyl-1-Diazridine

2-Methyl-2-Nitropropane

2,4-Dimethyl Inidazoline

3,6-Dipropyl-1,2,4,5-Tetrazine

$\beta$ -Keto-1-Nitropropane

Phenyl Cyanide

Nitro-olefins have been postulated as one of the lacrimatory constituents of smog, and they have been shown to be potent lacrymators at 0.1 - 0.5 ppm (Lampe et al., 1958). They may be formed in urban atmospheres through a complex set of reactions involving  $\text{NO}_2$  and hydrocarbons. Exposure to nitro-olefins has been shown to produce severe pathological changes in the lungs of rabbits, including extensive hemorrhage, edema, and emphysema (Deichmann et al., 1965). Exposure of guinea pigs to low concentrations also produced changes in pulmonary function. These included increases in pulmonary flow resistance and tidal volume and decreases in respiratory rate. The running activity of the guinea pigs was also noted to decrease. These effects were observed to be reversible after exposure for 2 - 6 hours (Surgeon General, 1962). MacDonald et al. (1963) exposed rats to 4 nitro-olefins including 3-nitro-3-hexene, and observed hemopoietic changes including increased hemoconcentrations and increased levels of immature red blood cells. Most importantly, Diechmann et al. (1963, 1965) exposed mice and rats chronically to one of the nitro-olefins identified in the exhaust of spark-ignition engines. They reported development of primary adenocarcinoma of the lung in 18.5% of the mice exposed for 18 months. Six percent of the rats exposed for 36 months developed undifferentiated carcinoma of the lung. From these data, they concluded that 3-nitro-3-hexene is a potential carcinogen.

## 2.5 Summary

Molecular nitrogen is the only clearly innocuous N-species. Other members of the family of gas phase nitrogenous species are odorants or lacrymators at low concentrations, affect visibility, play a

role in the formation of photochemical smog, take part in atmospheric reactions which threaten the ozone layer, are capable of shifting the energy balance of the earth, are toxic at low levels, are precursors of carcinogens, or are directly carcinogenic. Table 2-10 summarizes the effects of the various N-species, as detailed in this chapter.

The most important N-species, from the public health and air pollution perspectives, are NO, NO<sub>2</sub>, N<sub>2</sub>O, HCN, NH<sub>3</sub>, and nitrosamines. In addition, the alkylamines, nitrates, and nitro-olefins may also be significant air pollutants. This evaluation is based not only on toxicological data and atmospheric chemistry, but also on estimated magnitude of sources, as discussed in Chapters 3 and 4.

TABLE 2-10. Adverse Effects of Nitrogenous Species

COMPOUND	SYMBOL	TOXICITY					ATMOSPHERIC CHEMISTRY			
		Carcinogenic	Carcinogen Precursor	TLV (ppm)	EPL (ppb)	Measured Concentration (ppm)	Greenhouse Effect	Affect Visibility	Role in Smog	Destroy O <sub>3</sub>
Nitric Oxide	NO	-	+	25	40	.02-3.7	-	-	+	+
Nitrogen Dioxide	NO <sub>2</sub>	-	+	5	50*	.02-1.3	-	+	+	+
Nitrous Oxide	N <sub>2</sub> O	-	-	-	?	.3	+	-	-	+
Hydrogen Cyanide	HCN	-	-	10	17	NA**	-	-	HC****	-
Methyl Cyanide	CH <sub>3</sub> CN	-	-	40	66	NA	-	-	HC	-
Ethyl Cyanide	CH <sub>3</sub> CH <sub>2</sub> CN	-	-	-	-	-	-	-	-	-
Vinyl Cyanide	CH <sub>2</sub> CHCN	-	-	20***	33	NA	-	-	HC	-
Cyanogen	C <sub>2</sub> N <sub>2</sub>	-	-	10***	17	NA	-	-	HC	-
Glycoconitrile	HOCH <sub>2</sub> CN	-	-	-	?	NA	-	-	HC	-
Ammonia	NH <sub>3</sub>	-	?	50	83	.005-.2	+	-	?	-
Nitrosamines	RNNO	+	-	-	.5-2	-	-	-	-	-
Alkyamines	RNH <sub>i</sub>	-	+	10	17	to .008	-	-	HC	-
Nitroparaffins		-	-	100	165	NA	-	-	HC	-
Nitrates	RNO <sub>3</sub>	-	+	-	?	NA	-	-	HC	-
Nitro-Olefins		+	-	-	-	NA	-	-	HC	-

\* Federal Air Quality Standard

\*\* Not Available

\*\*\* Suggested

\*\*\*\* May affect smog as a hydrocarbon or as a source of N

### CHAPTER 3

#### Fuel Nitrogen Investigations

Previous investigations of fuel nitrogen conversion will be reviewed in this chapter. Topics will include pyrolysis of fuel nitrogen compounds and fuels containing bound nitrogen, fuel nitrogen investigations in premixed combustion systems, fuel nitrogen studies in turbulent diffusion flame systems, and general conclusions which may be drawn from these investigations. First, a few general characteristics of fuel nitrogen will be discussed.

The increasing severity of the fossil fuel shortage has already impacted on the air pollution problem in the United States and promises to have an even greater influence in the future. Recent declarations of "energy states of emergency" in several states in the Northeast emphasize the fact that domestic use must be given first priority in the allocation of natural gas. In response to this policy, industrial and commercial energy consumers are converting to the use of coal, residual fuel oil, and other fuels which contain high concentrations of bound nitrogen.

Unfortunately, combustion of fuels containing relatively high concentrations of bound nitrogen, or fuel nitrogen as it is commonly called, leads to the emission of large quantities of oxides of nitrogen ( $\text{NO}_x$ ).

In fact, it has been estimated that as much as half of the  $\text{NO}_x$  emissions from stationary sources are due to fuel nitrogen (Sarofim

and Flagan, 1976). As shown in Table 3-1, in July 1976 coal was the primary energy source for 44.2% of the energy consumed by electric utilities. Petroleum contributed 14.6% and natural gas was 16.9%. The amount of natural gas consumed by the electric utilities may be expected to decrease sharply and the consumption of coal and petroleum and, to a lesser extent, hydroelectric and nuclear energy will increase proportionately. Similarly, 46.2% of industrial process heat is derived from the consumption of natural gas, and this should be expected to decrease in the near future. The same publication (Gaynor, 1976) reports that between July 1975 and July 1976 consumption of residual fuel oil increased by 14.1%, consumption of coal increased 10.7%, and consumption of natural gas increased only 1.3%. In comparison, total energy use increased 5.5%, residential and commercial energy use increased only 1.0%, industrial use increased 9.7%, and transportation use increased by 5.8%. These data indicate that the industrial change to coal and residual fuel oil is progressing fairly rapidly. The fuel-NO<sub>x</sub> problem will become even more severe as the switch to these nitrogen-containing fuels approaches completion.

As pointed out by Appleton and Heywood (1973), fuel nitrogen reacts much more readily to form nitric oxide than does atmospheric nitrogen. Only a very small fraction of the N<sub>2</sub> in the reactants of a typical combustion system will be oxidized to NO. However, close to 100% of the fuel bound nitrogen may be oxidized to NO under certain combustion conditions. The molecular bonding involved indicates one reason for this phenomenon. Molecular nitrogen possesses a triple bond with a dissociation energy of 943 kJ/mole. This is much higher than the energy involved in the CN and NH bonds typical of fuel nitrogen compounds.

TABLE 3-1

Primary Energy Consumption by Sector and Source - July 1976\*

	COAL	PETROLEUM**	NATURAL GAS	HYDROELECTRIC AND NUCLEAR	PRIMARY ENERGY CONSUMPTION (10 <sup>15</sup> Btu)
Residential and Commercial	1.6%	61.8%	36.6%	—	.812
Industrial	22.7%	30.9%	46.2%	.2%	1.482
Transportation	<0.1%	97.7%	2.1%	Negligible	1.624
Electric Utilities	44.2%	14.6%	16.9%	23.8%	1.971
Percent of Total Energy Consumption	20.7%	48.1%	23.1%	8.0%	5.89

\* From data tabulated by the Federal Energy Administration (Gaynor, 1976)--Rows may not add to 100% because of round-off errors.

\*\* Includes gasoline, jet fuel, residual fuel oil, distillate fuel oil, and other minor petroleum products. Residual fuel oil accounted for 17.5% of the refined petroleum products which were consumed in July 1976.

Table 3-2 lists the fuels which contain significant bound nitrogen and gives the average nitrogen concentrations in percent by weight. Nitrogen may be bound within a fuel in several different forms. It may be bound in a side chain as an amine or in ring compounds such as the pyridines or carbazoles. Table 3-3 shows the typical ring structures of nitrogen compounds in fossil fuels. In addition, synthetic gaseous fuels such as those derived from coal may contain relatively high concentrations of  $\text{NH}_3$  and HCN.

### 3.1 Thermal and Oxidative Pyrolysis

Most commercial combustion devices have turbulent diffusion flames. In turbulent diffusion combustion, the fuel will thermally decompose (pyrolyze) before combustion, yielding a variety of low molecular weight compounds. The fuel nitrogen compounds also break down into lower molecular weight species. A knowledge of what these species are is important from the perspective of chemical mechanism, kinetics, and modeling. Fuel nitrogen pyrolysis studies are divided into two categories: pyrolysis of fuels containing bound nitrogen and pyrolysis of fuel nitrogen compounds.

Blair et al. (1977) studied the pyrolysis of single microparticles of coal at a heating rate comparable to that in a combustion environment: 20,000 K/sec. With the final temperature set at 1670 K, the yields of HCN and  $\text{NH}_3$  were 5 and 10% respectively. They found that 80 - 85% of the nitrogen was retained in the char and that this fraction increased with decreasing final temperature.

Pohl and Sarofim (1977) found that the long-term retention of nitrogen in the char decreased monotonically with increasing temperature, from virtually 100% below 700 K to 50% at 1400 K to 0% above 1750 K.

TABLE 3-2

Typical Nitrogen Content of Fuels

<u>Fuel</u>	<u>Avg. Nitrogen</u> (wt %)	<u>Range</u> (wt %)	<u>Reference</u>
Crude	0.65		Ball and Roll, 1962
Asphaltine	2.30	2.15-2.50	Ball and Roll, 1962
Heavy Distil- lates (#4,5,6)	1.40	0.60-2.15	Ball and Roll, 1962
Light Distil- lates (#1,2,3)	0.07	0-0.60	Ball and Roll, 1962
Crude	1.14		Nelson, 1958
Oil Shale Syncrude	2.10		U.S. Navy, 1975
Coal Syncrude	0.08		Jones, 1966
Coal	1.40		Sarofim and Flagan, 1976
Crude	.07-.49		Sarofim and Flagan, 1976
Hot Coal Gas	to 0.4		Heap et al., 1977

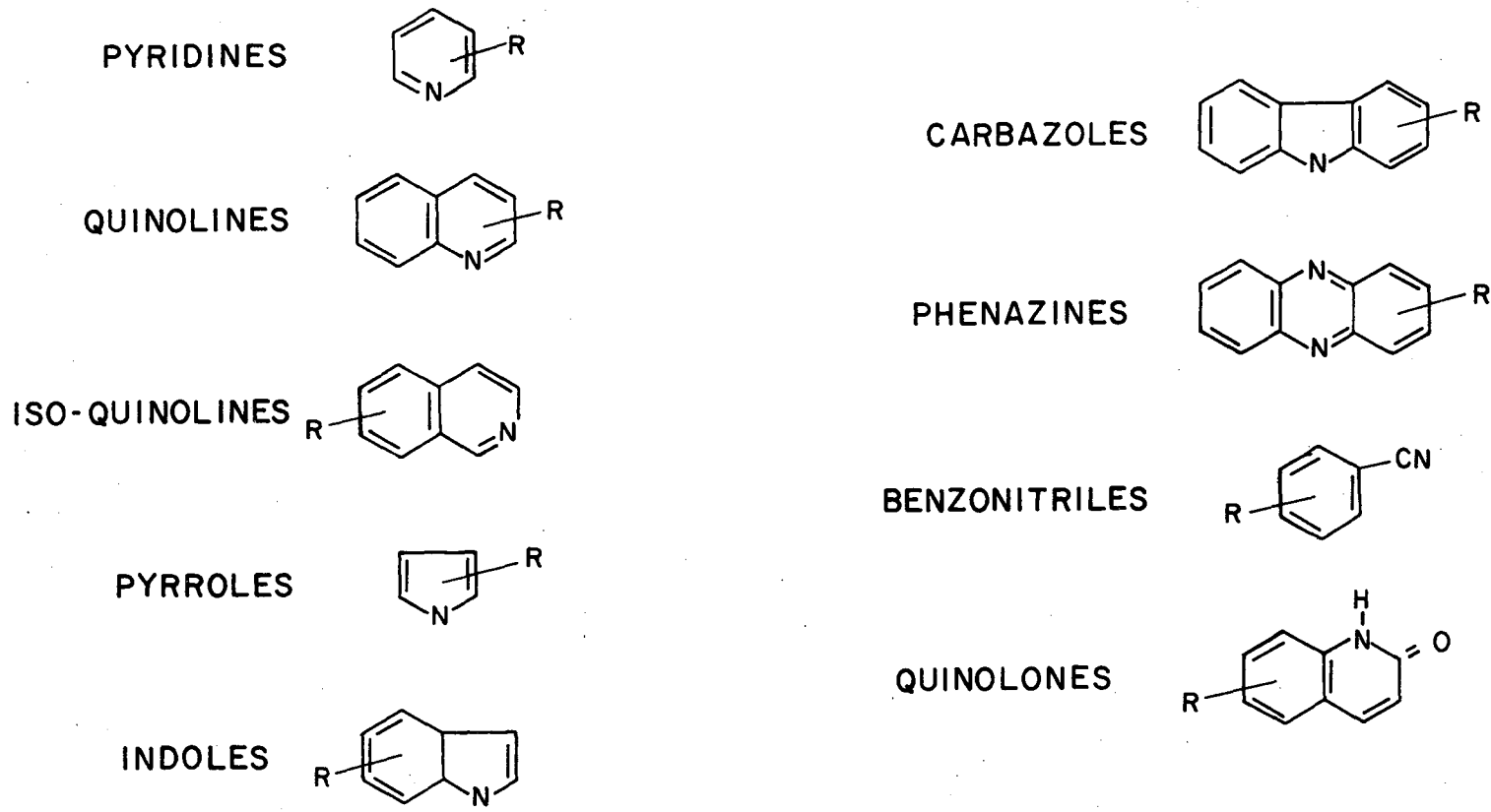

Table 3-3. Nitrogen Compounds in Fossil Fuels (Axworthy and Schuman, 1973)

00004901082  
-65-

This observation is not in agreement with Blair et al. (1977) but does correspond to the results obtained by Axworthy et al. (1975).

Axworthy et al. (1975) and Axworthy and Dayan (1977) studied the inert pyrolysis of No. 6 fuel oil, coal, char, crude oil, liquefied coal, and two treated shale oils. The results of the inert pyrolysis investigation are shown in Table 3-4. The oil pyrolysis experiments revealed that significant conversion to HCN occurs at 1230 K and the fraction converted to HCN increases with increasing temperature. At 1380 K, the HCN yield ranged from 23 to 42%. For the coal samples, the fraction of the fuel nitrogen converted to HCN ranged from 24 to 30%. The char showed negligible conversion to HCN, possibly indicating that the nitrogen compounds in the char are nonvolatile. The alternate fuels exhibited the greatest yield of HCN. Axworthy and Dayan (1977) suggest that this indicates that these alternate fuels may show a greater extent of conversion of fuel-N to  $\text{NO}_x$  during lean combustion. Another significant finding was that the inert pyrolysis of oils doped with benzonitrile (phenyl cyanide) and quinoline gave about the same HCN yields as was observed during the inert pyrolysis of the nitrogen containing additives by themselves. This suggests that there is no significant interaction between the nitrogenous compounds and the rest of the fuel. Secondly, this verifies the significance of the pyrolysis studies which have been conducted on model fuel nitrogen compounds.

Axworthy et al. (1975) and Axworthy and Dayan (1977) also studied the inert pyrolysis of pyridine, pyrrole, quinoline, and benzonitrile. They observed substantial conversion to HCN, with the yield of HCN increasing with increasing temperature. HCN was the sole nitrogenous product of the inert pyrolysis of pyridine at 1380 K. Under these same

TABLE 3-4  
 Results of the Inert Pyrolysis Studies of Axworthy et al. (1975) and Axworthy and Dayan (1977)

SAMPLE	%N	% Conversion at 1230 K		% Conversion at 1380 K	
		to HCN	to NH <sub>3</sub> + N <sub>2</sub>	to HCN	to NH <sub>3</sub> + N <sub>2</sub>
Gulf #6 Fuel Oil	1.41	23.2		38.8	
Conoco #6 Fuel Oil	0.30	20.4		42.0	
EPA #6 Fuel Oil	0.22	24.6	23.8 ± 5	37.0	28.2 ± 1.0
Ultrasystems #6	0.36	17.8		35.2	16.1
#6 from Venezuelan Crude	0.43	19.4		32.9	
#6, Mainly California	1.41	14.5	5.2 ± .8	23.2	5.9 ± .4
Wilmington Crude	0.63	30.3	10.5 ± .8	49.8	10.9 ± .2
Liquefied Coal (Synthoil)	1.30			51.0 ± .3	
Full Boiling Range Shale Oil	0.27			60.0 ± 1.3	
Middle Distillate Shale Oil	0.18			69.5 ± 2.5	
Pittsburg #8 Coal	1.20			23.6 ± 1.5	
Montana Lignite -A	0.61			23.8 ± 1.6	
Montana Coal	0.93			26.8 ± .3	
Coed Char	0.99			1.7 ± .1	
EPA Bituminous	1.17			30.0	
IFRF Bituminous	1.80			24.5	

00004901083

conditions, 82% of the nitrogen in benzonitrile was converted to HCN. At 1230 K, about 50% of the nitrogen in benzonitrile was converted to HCN. Also at 1230 K, they report that the nitrogenous products of pyridine pyrolysis were: HCN (40%), NH<sub>3</sub> (<8%), N<sub>2</sub> (<0.1%), vinyl cyanide (3%), quinoline (3%), and benzonitrile (5%) with 49% of the nitrogen remaining in the residue.

The oxidative pyrolysis of benzonitrile and quinoline was also studied by Axworthy et al. (1975) and Axworthy and Dayan (1977). They found that oxidative pyrolysis is more rapid than thermal pyrolysis. The rate of pyrolysis increased with increasing temperature and oxygen concentration. For oxidative pyrolysis below approximately 1025 K, HCN and NH<sub>3</sub> were the major identified pyrolysis products. Above 1025, the fuel-N was predominantly pyrolyzed to N<sub>2</sub>, N<sub>2</sub>O, NO, and NO<sub>2</sub>. They found that the nitrogenous species in fossil fuels should decompose in fractions of a millisecond for temperatures above 2000 K. They postulate that "when a diffusion flame surrounds a coal particle or oil droplet the volatile fuel nitrogen compounds will be mostly converted to HCN before reaching the flame front."

Jolley (1934) found that the thermal decomposition of methylamine proceeded via the reactions

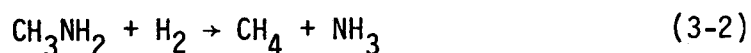

Low temperature oxidation followed the following mechanism:

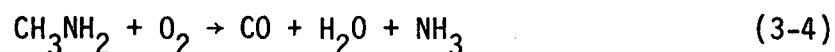
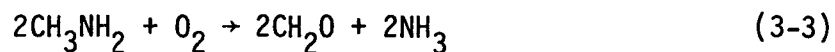

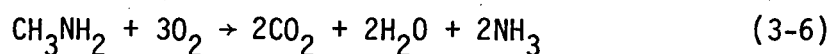

Therefore, for thermal pyrolysis HCN and  $\text{NH}_3$  were the major nitrogenous products but for oxidative pyrolysis,  $\text{N}_2$  was also important. The  $\text{N}_2$  concentration increased with temperature.

The thermal oxidation of methylamine was also studied by Cullis and Smith (1950). In addition, they studied ethylamine, n-propylamine, and n-butylamine. However, they only analyzed for the pyrolysis products of ethylamine and propylamine. At temperatures less than 600 K, HCN was not formed in detectable concentrations, but it did become a significant product at higher temperatures though.  $\text{NH}_3$  and  $\text{NO}_x$  were the major products for the range of temperatures studied. At temperatures less than 600 K, excess  $\text{O}_2$  was reported to promote the formation of  $\text{NO}_x$ .

Smith and Sawyer (1976a, b) also studied the pyrolysis and thermal oxidation of methylamine. They found that the major N-containing pyrolysis products were  $\text{N}_2$  and  $\text{NH}_3$  between 1007 and 1167 K.  $\text{NH}_3$ ,  $\text{NO}_x$ , and  $\text{N}_2$  were the major products of thermal oxidation between 1320 and 1600 K and  $\text{N}_2\text{O}$  was tentatively identified in the oxidation products.

In contrast to the conclusions of Jolley (1934) and Cullis and Smith (1950), Axworthy (1975) and Smith and Sawyer (1976) conclude that considerable pyrolysis can occur in the pre-flame region. The four groups of researchers agree that the activation energy for the global oxidation rate is significantly lower than that for thermal pyrolysis.

In summary, pyrolysis studies have found that low molecular weight N-species such as  $N_2O$ ,  $NO_2$ , HCN,  $NH_3$ , NO, and  $N_2$  are the most significant products of the pyrolysis of fuels and fuel nitrogen compounds. This implies that these gaseous species may be used in fuel nitrogen investigations to model the behavior of the higher molecular weight compounds normally found in commercial fuels.

### 3.2 Fuel Nitrogen Investigations Using Premixed Combustion Systems

Premixed combustion systems are important laboratory tools because they allow a decoupling of the interaction of fluid mechanics and chemical kinetics. That is, premixed combustion, with the exception of catalytic combustion, is kinetically rate limited rather than diffusion limited. The advantages derived from ignoring the role of fluid mechanics include making meaningful determinations of the effect of equivalence ratio and flame temperature on the exhaust properties of interest. In a turbulent diffusion flame, the equivalence ratio is a position dependent parameter and there are significant localized temperature gradients. Some premixed combustion systems have the added advantage of one-dimensionality. Among other advantages, this allows investigation into species concentration and flux profiles. These in turn may lead to the determination of chemical mechanisms and kinetic rate coefficients. For these reasons, review of previous premixed combustion investigations of fuel nitrogen conversion are of interest.

There have been many studies of the oxidation of  $NH_3$ , most of which

were not related to the fuel nitrogen problem. These studies are listed in Table 3-5 and summarized by Sawyer et al. (1976). These investigations are of interest because they develop important information about the chemical interaction of  $\text{NH}_3$ ,  $\text{NO}$ ,  $\text{N}_2$ , and  $\text{O}_2$ . However, because these studies were conducted in hydrocarbon free systems, their results are not directly applicable for the purposes of this thesis.

In the same manner, there have been a number of studies of individual reactions of importance in the fuel nitrogen conversion mechanism. These also are reviewed by Sawyer et al. (1976) and will not be discussed further.

A significant amount of fuel nitrogen research has been done in premixed systems in which the only nitrogenous species measured were  $\text{NO}$  and  $\text{NO}_2$ . These investigations are summarized in Table 3-6. Bartok et al. (1971) examined the effect of model fuel nitrogen compound type on conversion to  $\text{NO}$  in a jet stirred reactor. Comparing addition of  $\text{NO}$ ,  $\text{NO}_2$ ,  $\text{NH}_3$ ,  $\text{C}_2\text{N}_2$ , and  $\text{CH}_3\text{NH}_2$ , they observed that conversion to  $\text{NO}$  was similar for all additives as a function of equivalence ratio. However, the  $\text{NO}$  yield was noted to differ according to additive type by as much as +20%. Fenimore (1972), however, finds that the  $\text{NO}$  yield is approximately independent of additive type for  $0.9 < \phi < 2.0$ ,  $1860 < T < 2250$ , and the four additives:  $\text{NH}_3$ ,  $\text{C}_5\text{H}_5\text{N}$ ,  $\text{CH}_3\text{NH}_2$ , and methacrylonitrile. Merryman and Levy (1974) note the appearance of  $\text{NO}_2$  as an intermediate in the fuel nitrogen conversion mechanism. They suggest that ring-structured compounds react to form  $\text{NO}$  via similar paths, thus explaining their observation that pyridine and piperidine had about the same  $\text{NO}$  yields despite their quite different stabilities.

TABLE 3-5

## Investigations of Ammonia Oxidation in Premixed Combustion Systems

<u>Authors</u> <u>(Date)</u>	<u>Apparatus</u>	<u>Fuel/Oxidizer</u>	<u>Measured Species</u>	<u>Measurement Method</u>
Duxbury & Pratt (1973)	Incident Shock	NH <sub>3</sub> /O <sub>2</sub> -Ar NH <sub>3</sub> /NO-Ar H <sub>2</sub> /NO <sub>2</sub> -Ar H <sub>2</sub> /NO-Ar H <sub>2</sub> /O <sub>2</sub> -NO-Ar	NH <sub>3</sub> , H <sub>2</sub> O, NO <sub>2</sub> , NO	Spectra
Duxbury & Pratt (1974)	Incident Shock	NH <sub>3</sub> /NO-Ar H <sub>2</sub> /NO-Ar	OH, NO, NH <sub>3</sub> , NH	Spectra
Kaskan & Hughes (1973)	FFB	NH <sub>3</sub> /O <sub>2</sub>	T OH, NH, NH <sub>3</sub> , NO	Na Line Spectra
MacLean & Wagner (1967)	low p FFB (20 mm Hg)	NH <sub>3</sub> /O <sub>2</sub>	T H <sub>2</sub> , H <sub>2</sub> O, N <sub>2</sub> O, NO, NH <sub>3</sub> , N <sub>2</sub> OH, NH, OH*, NH*, NO*, NH <sub>2</sub> *	Pt/Pt-Rh MS SPM
Nadler, Wang & Kaskan (1970)	FFB	NH <sub>3</sub> /O <sub>2</sub> -N <sub>2</sub>	OH, NH, Relative NH <sub>2</sub>	Optically
Sawyer, MacLean Maes & (1972)	FFB	NH <sub>3</sub> /O <sub>2</sub> NH <sub>3</sub> /O <sub>2</sub> -N <sub>2</sub>	T H <sub>2</sub> , O <sub>2</sub> , NO, NH <sub>3</sub> , N <sub>2</sub> H <sub>2</sub> O	Pt/Pt-Rh MS Inferred

TABLE 3-6  
 Summary of Fuel Nitrogen Investigations in Premixed Combustion Systems  
 in Which NO and NO<sub>2</sub> were the Only Nitrogenous Species Measured

<u>Authors</u> (Date)	<u>Apparatus</u>	<u>Fuel/Oxidizer</u>	<u>Additive</u>	<u>Probe</u>	<u>Measured Species</u>	<u>Measurement Method</u>
Bartok, et al. (1971)	Jet Stirred Reactor	CH <sub>4</sub> /Air	NO NO <sub>2</sub> NH <sub>3</sub> C <sub>2</sub> N <sub>2</sub> Methalymine	H <sub>2</sub> O cooled	T O <sub>2</sub> O <sub>2</sub> , CO, CO <sub>2</sub> , H <sub>2</sub> , HC's, N <sub>2</sub> SO <sub>2</sub> , NO, NO <sub>2</sub>	Pt/Pt-Rh Paramagnetic GC EMA
Fenimore (1972)	Shielded Meker	C <sub>2</sub> H <sub>4</sub> O <sub>2</sub> -N <sub>2</sub> (or Ar)	NH <sub>3</sub> Pyridine Methalamine Methacrylonitrile	Quartz	T NO	Na Line Chemical
Leonard, Plee & Mellor (1976)	low p FFB (.67 atm)	CH <sub>4</sub> /Air	NH <sub>3</sub>	Quartz	T NO NO <sub>2</sub> CO, CO <sub>2</sub> , CH <sub>4</sub> , H <sub>2</sub> , O <sub>2</sub> , N <sub>2</sub>	Pt/Pt-Rh CLA NDUV GC
Merryman & Levy (1973)	FFB	CH <sub>4</sub> /Air	Monomethyl- amine		NO NO <sub>2</sub>	CLA CLA, Saltzman
Merryman & Levy (1974)	1) FFB 2) low p FFB	CH <sub>4</sub> /Air	Methylamine Pyridine Piperidine	H <sub>2</sub> O cooled	T Stable species O NO NO <sub>2</sub> Fuel N	Pt/Pt-Rh MS NO <sub>2</sub> Titration CLA CLA, Saltzman CLA w/converter

00304901086  
-73-

TABLE 3-6  
(continued)

<u>Authors</u> (Date)	<u>Apparatus</u>	<u>Fuel/Oxidizer</u>	<u>Additive</u>	<u>Probe</u>	<u>Measured Species</u>	<u>Measurement Method</u>
Wendt & Sternling (1974)	Modified Meker	CH <sub>4</sub> /Air	NH <sub>3</sub>		O <sub>2</sub> CO NO <sub>x</sub> , NO <sub>2</sub>	715 NDIR EMA
Wendt Sternling & Matovich (1974)	Meker	CH <sub>4</sub> /Air	NH <sub>3</sub>	Quartz	O <sub>2</sub> CO NO <sub>x</sub>	715 NDIR EMA

Wendt and Sternling (1974) found that the NO yield decreased with increasing equivalence ratio. The NO yield is high and fairly constant for fuel lean flames but drops rapidly for equivalence ratios greater than 1.0.

A number of fuel nitrogen investigations have been carried out in hydrocarbon-free combustion systems. These studies, which yield information which is particularly useful in promoting an understanding of chemical mechanisms, are listed in Table 3-7. Some of them will be mentioned in relation to fuel nitrogen modeling, section 3.4.

Of further interest are the fuel-N investigations in which a variety of nitrogenous intermediates and products were measured. These investigations are listed in Table 3-8 along with pertinent information about the experimental apparatus and measurement techniques. Haynes (1977a) reports that only HCN and NO leave the primary reaction zone of a Meker burner, and  $\text{NH}_i$  species are formed in the post flame gases. In high temperature flames (2070 K), HCN decays rapidly in the post flame zone while NO increases and the  $\text{NH}_i$  remain at a very low value. However, he finds that "the stability of the nitrogen system as a whole ... is very sensitive to the flame temperature." At 1950 K, the HCN decay rate is significantly slower, the  $\text{NH}_i$  are increasing with time and NO is decreasing. This indicates that, in a turbulent diffusion flame where temperature gradients are steep, HCN and  $\text{NH}_i$  may be released as products because the appropriate removal reactions may be quenched. Malte et al. (1976) studied the addition of  $\text{C}_5\text{H}_5\text{N}$ ,  $\text{NH}_3$ , and NO to  $\text{C}_3\text{H}_8$ /air combustion in a jet-stirred reactor. The behavior of the additives was similar as a function of equivalence ratio, producing high NO yields in fuel lean flames and a yield which dropped rapidly with

TABLE 3-7. Fuel Nitrogen Investigations in Hydrocarbon-Free Systems

<u>Authors</u> (Date)	<u>Apparatus</u>	<u>Fuel/Oxidizer</u>	<u>Additive</u>	<u>Probe</u>	<u>Measured Species</u>	<u>Measurement Method</u>
Balakhnine et al. (1977)	FFB	H <sub>2</sub> /N <sub>2</sub> O			NO, N <sub>2</sub> , N <sub>2</sub> O H <sub>2</sub> , O <sub>2</sub>	MS
Bowman (1972)	Reflected Shock	H <sub>2</sub> /O <sub>2</sub> /Ar	NH <sub>3</sub>		OH, H <sub>2</sub> O, NO	Spectra
Flower et al. (1975)	Incident Shock	NO/H <sub>2</sub> /Ar or Kr	NO		NO	Spectra
Kahn & Axworthy (1977)	FFB	H <sub>2</sub> /CO/O <sub>2</sub> /Ar	NH <sub>3</sub>	Quartz	NO, NO <sub>2</sub> , NH <sub>3</sub> HCN	CLA
Koshi et al. (1975)	Incident Shock	NO/Ar NO/H <sub>2</sub> /Ar	NO		T O NO	Unspecified Spectra
Lyon (1976)	Flow Reactor	NH <sub>3</sub> /NO/O <sub>2</sub>		Quartz	NO, NO <sub>2</sub> NH <sub>3</sub>	CLA Wet Chem
Mulvihill & Phillips (1975)	FFB	H <sub>2</sub> /O <sub>2</sub> /N <sub>2</sub>	C <sub>2</sub> N <sub>2</sub>		HCN CO <sub>2</sub> H <sub>2</sub> O H, CN NO, NH, CH	MS Flame Photometry Spectra
Seery & Zabielsky (1977)	FFB	CO/O <sub>2</sub>	NH <sub>3</sub>	Quartz	NO, N <sub>2</sub> , NH <sub>3</sub>	MS

TABLE 3-8

Summary of Fuel Nitrogen Investigations in Premixed Combustion Systems  
in Which Nitrogenous Species Other than  $\text{NO}_x$  were Measured

<u>Authors</u> (Date)	<u>Apparatus</u>	<u>Fuel/Oxidizer</u>	<u>Additive</u>	<u>Probe</u>	<u>Measured Species</u>	<u>Measurement Method</u>
Axworthy (1975)	low p FFB (.1 atm)	$\text{CH}_4/\text{O}_2\text{-Ar}$	$\text{NCH}$ $\text{NH}_3$ $\text{NO}^3$	Quartz	T $\text{O}_2, \text{CH}_4, \text{CO}_2, \text{CO}$ $\text{HCN}, \text{NH}_3, \text{NO}$	TC
de Soete (1974)	FFB	$\text{C}_2\text{H}_4$ $\text{O}_2\text{-Ar}(\text{or He})$	$\text{NH}_3$ Amines		T $\text{O}_2, \text{H}_2, \text{CO}_2, \text{CO},$ $\text{NO}$ $\text{HCN}$	Na Line GC NDIR, CLA Chemical
de Soete (1974)	FFB	$\text{C}_2\text{H}_4$ $\text{O}_2\text{-Ar}(\text{or He})$	$\text{NH}_3$ $\text{C}_2\text{N}_2$	$\text{H}_2\text{O}$ cooled SS	T $\text{O}_2, \text{H}_2, \text{CO}_2, \text{CO},$ $\text{NO}, \text{NO}_2$ HC's $\text{C}_2\text{N}_2, \text{HCN}$	Na Line GC CLA Chemical
Haynes, Iverach & Kirov (1974)	Meker	$(\text{C}_3\text{H}_8, \text{CH}_4,$ $\text{H}_2/\text{CO}, \text{C}_2\text{H}_2,$ $\text{C}_2\text{H}_4/\text{Air})$	$\text{C}_5\text{H}_5\text{N}$ $\text{NO}$	$\text{H}_2\text{O}$ cooled Silica & Alumina	T $\text{CO}, \text{CO}_2$ $\text{O}_2$ $\text{NO}$ $\text{NH}, \text{NH}_2, \text{NH}_3, \text{H}$ CN-species	Na Line NDIR Paramagnetic CLA Chemical
Haynes (1977)	Meker	$\text{C}_2\text{H}_4/\text{Air-N}_2$ $\text{C}_2\text{H}_2/\text{Air}$	$\text{NH}_3$ $\text{NO}$ $\text{C}_5\text{H}_5\text{N}$	$\text{H}_2\text{O}$ cooled Silica	$\text{CN}^-, \text{NH}_i$ H NO	Ion electrodes Li/LiOH NDIR
Kahn & Axworthy (1977)	low p FFB	$\text{CH}_4/\text{O}_2\text{-N}_2$	$\text{NH}_3$ $\text{HCN}$	Quartz	$\text{NO}, \text{NO}_2, \text{NH}_3, \text{HCN}$ $\text{CH}_4, \text{CO}, \text{CO}_2, \text{O}_2,$ $\text{H}_2, \text{N}_2$	CLA MS

00004901088  
-77-

TABLE 3-8  
(continued)

<u>Authors</u> (Date)	<u>Apparatus</u>	<u>Fuel/Oxidizer</u>	<u>Additive</u>	<u>Probe</u>	<u>Measured Species</u>	<u>Measurement Method</u>
Malte et al. (1976)	JSR	C <sub>3</sub> H <sub>8</sub> /Air	C <sub>5</sub> H <sub>5</sub> N NH <sub>3</sub> NO		NO <sub>x</sub> HCN, NH <sub>3</sub> CH <sub>3</sub> CN, CH <sub>2</sub> CHCN	CLA Wet Chem GC
Puechberty & Cottureau (1977)	FFB	C <sub>3</sub> H <sub>8</sub> /O <sub>2</sub>	NH <sub>3</sub>		CN*, CN	Optical

increasing equivalence ratio (above 1.0). However, they noted that the yields of HCN and  $\text{NH}_3$  were increasing with equivalence ratio in fuel rich flames and that the HCN and  $\text{NH}_3$  yields were greater than the NO yield at  $\phi = 1.4$ . At this same condition, they identified  $\text{CH}_3\text{CN}$  and  $\text{CH}_2\text{CHCN}$  in the exhaust. In agreement with other researchers, they observed a decreasing NO yield with increasing fuel nitrogen concentration.

In summary, the premixed combustion experiments have shown that the NO yield from fuel nitrogen combustion is a strong function of equivalence ratio and a weak function of additive (fuel nitrogen compound) type. The NO yield is inversely proportional to the fuel nitrogen concentration. Intermediates such as HCN,  $\text{NH}_3$ , and  $\text{NO}_2$  may be important in the NO formation mechanism. These species and larger nitrogenous molecules may be emitted as products under certain combustion conditions, such as very fuel rich operation. Production of HCN and  $\text{NH}_3$  is very temperature sensitive.

### 3.3 Fuel Nitrogen Investigations Using Diffusion Flame Systems

Turbulent diffusion flame studies of fuel nitrogen conversion are listed in Table 3-9 along with information about the experimental apparatus and measurement techniques. Some of these investigations were intended to evaluate  $\text{NO}_x$  control methods and fuel nitrogen was only of secondary interest. In most of these studies,  $\text{NO}_x$  was the only N-species which was analyzed. Some, however, did study the role of odd nitrogenous species in fuel nitrogen combustion. Some of the significant findings of these investigations will be discussed in the following paragraphs.

Fine et al. (1971) compared fuel nitrogen conversion in premixed

TABLE 3-9

## Summary of Fuel Nitrogen Investigations in Diffusion Flames

<u>Authors (Date)</u>	<u>Apparatus</u>	<u>Fuel/Oxidizer</u>	<u>Additive</u>	<u>Probe</u>	<u>Measured Species</u>	<u>Measurement Method</u>
Appleton & Heywood (1973)	Continuous Flow Combustor	Kerosene/Air	C <sub>5</sub> H <sub>5</sub> N		CO, O <sub>2</sub> , NO CN CN-species	Not specified Spectra Chemical
Blakeslee & Burbach (1973)	Tangentially Fired Boiler	Gas/Air Oil/Air Coal/Air			O <sub>2</sub> NO <sub>x</sub>	Paramagnetic Chemical Electrochemical
Fenimore (1976)	Diffusion Flame	CH <sub>4</sub> -H <sub>2</sub> /O <sub>2</sub> -N <sub>2</sub> (or Ar or He)	C <sub>5</sub> H <sub>5</sub> N		NO	
Fine et al (1971)	Experimental Burner	CH <sub>4</sub> /Air	Monomethylamine	SS	NO	CLA
Haynes & Kirov (1974)	Pot-Furnace	Coal/Air			T O <sub>2</sub> CO <sub>2</sub> , NO	Pt/Pt-Rh Paramagnetic NDIR
Martin & Berkau (1971)	Experimental Furnace	Distillate Oil/Air	C <sub>5</sub> H <sub>5</sub> N		T CO, CO <sub>2</sub> O <sub>2</sub> HC's NO	TC NDIR Paramagnetic FID NDIR
Pereira, et al (1974)	Fluidized Bed	Coal/O <sub>2</sub> -Ar			N <sub>2</sub> , O <sub>2</sub> , CO, CO <sub>2</sub> , H <sub>2</sub> , CH <sub>4</sub> NO <sub>x</sub>	GC CLA

TABLE 3-9  
(continued)

<u>Authors (Date)</u>	<u>Apparatus</u>	<u>Fuel/Oxidizer</u>	<u>Additive</u>	<u>Probe</u>	<u>Measured Species</u>	<u>Measurement Method</u>
Pershing & Wendt (1977)	Turbulent Diffusion Flame	Coal/O <sub>2</sub> -N <sub>2</sub>		H <sub>2</sub> O cooled SS	CO, CO <sub>2</sub> , O <sub>2</sub> , SO <sub>2</sub> NO/NO <sub>x</sub>	— CLA
Pohl & Sarofim (1976)	Muffle Tube	Coal/O <sub>2</sub> -He			NO	—
Shaw & Thomas (1968)	Coal Combustor	Coal/Air			NO <sub>x</sub>	Chemical Hersch NO <sub>2</sub> sensor Mast. NO <sub>2</sub> secsor
Siegmund & Turner (1974)	Package Boiler	Residual Fuel Oil/Air			CO <sub>2</sub> , CO, HC's, O <sub>2</sub> , NO <sub>x</sub>	Not specified
Yamagishi et al (1974)	2 Stage Combustor	CH <sub>4</sub> /Air	NO	Quartz	O <sub>2</sub> CO, CO <sub>2</sub> CH <sub>4</sub> , C <sub>2</sub> H <sub>2</sub> , C <sub>2</sub> H <sub>4</sub> , H <sub>2</sub> CO, N <sub>2</sub> NO, NO <sub>2</sub> HCN, NH <sub>3</sub>	Paramagnetic NDIR GC CLA Chemical

003049018-90

systems to that in diffusion flames. Figure 3-1 illustrates their findings. The NO yield was much higher for premixed flames than for diffusion flames. The premixed flames exhibited the characteristic decrease in NO yield with increasing fuel-N concentration but the NO yield was approximately independent of additive concentration for diffusion flames.

These findings are interesting when compared with the results of Takagi et al. (1977) who noted higher HCN formation in turbulent diffusion flames than in premixed flames. They also found that added NO decomposed to HCN in the fuel rich region while added NH<sub>3</sub> produced both NO and HCN. Under fuel-rich conditions, HCN and NH<sub>3</sub> were emitted from the combustion systems in concentrations of the order of or greater than NO emissions.

It should be noted that Yamagishi et al. (1974) also reported higher formation of HCN in turbulent diffusion flames than in premixed flames. Levels of NH<sub>3</sub> and NO were also higher in turbulent diffusion flames than in premixed combustion. This investigation is discussed in sections 4 and 5.

Pohl and Sarofim (1977) report that the NO yield from coal combustion decreases monotonically from ~ 60% at  $\phi = 0.2$  to less than 10% at  $\phi = 1.5$ . Most importantly, they found that 45% of the original coal nitrogen remained in the char (which was 30% unreacted) at  $\phi = 1.5$ . They go on to say "the presence of nitrogen in the char places constraints on the reduction of emissions of nitric oxide from coal fired units by the use of staged combustion, unless the first stage is operated at high enough temperatures to liberate most of the nitrogen."

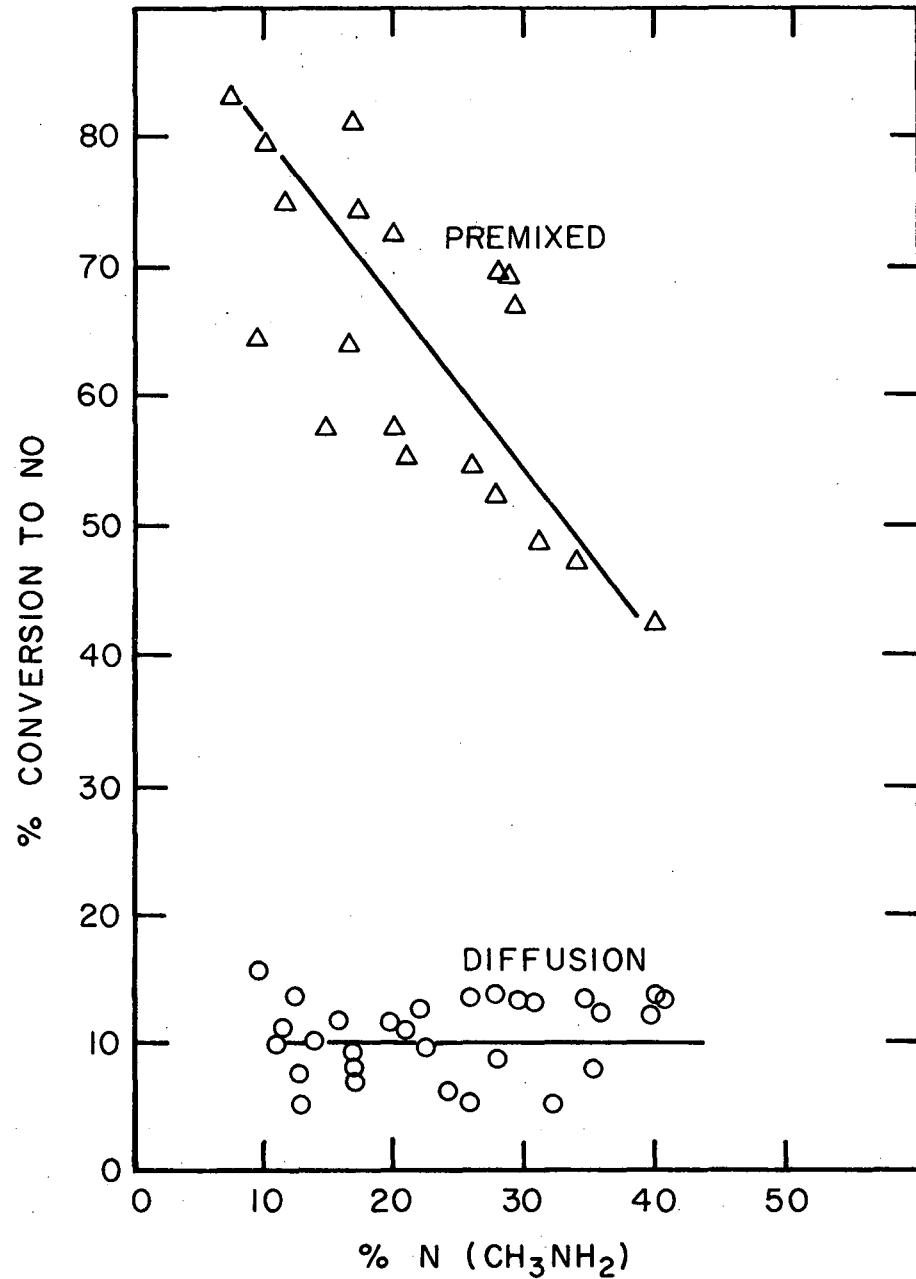

Figure 3-1. Effect of Fuel/Air Mixing on the Relationship Between Fuel Nitrogen Concentration and Nitric Oxide Yield for Fuel Lean Flames (Fine et al., 1971)

Appleton and Heywood (1973) found that the NO yield from a kerosene/air burner doped with pyridine ( $C_5H_5N$ ) was strongly influenced by the fuel/air mixing intensity. They tentatively detected between 30 and 500 ppm of CN species in the exhaust of their burner.

In a series of studies which will be discussed extensively in section 4.1.c, Stumpf and Blazowski (1976) and Conkle et al. (1976) compared nitrogenous organic emissions from a gas turbine burning JP4 and DEL-5. JP4 is a conventional jet fuel based on kerosene and DEL-5 is a blend of JP4, pyridine, and an aromatic stock which simulates an alternate jet fuel which might be produced from coal or an oil shale syncrude. The fuel-N concentration of DEL-5 is 0.3 wt. %. Under the same operating conditions, the nitrogenous organic emissions using DEL-5 were more than 3 times greater than those using JP4, as shown in Table 4-3. The major importance of this study is that it indicates that fuel-N may have a significant impact on emissions of N-species other than  $NO_x$  even in very fuel lean systems.

Sarofim and Flagan (1976) have condensed the results of several researchers to one graph, Figure 3-2, which shows the relation of fuel-N concentration to NO yield for oils and coals. As was observed in premixed combustion systems, the NO yield decreased with increasing concentrations of nitrogen in the fuel\*. The fate of the unaccounted for fuel-N is not clear and is probably a function of overall equivalence ratio, mixing intensity, temperature history, and residence time. For the coals, a portion of the nitrogen may remain in the residue.

---

\*This is in contrast to the work of Fine et al. (1971). The discrepancy may reflect the differences in gaseous versus non-gaseous fuels or may be a function of other combustion parameters.

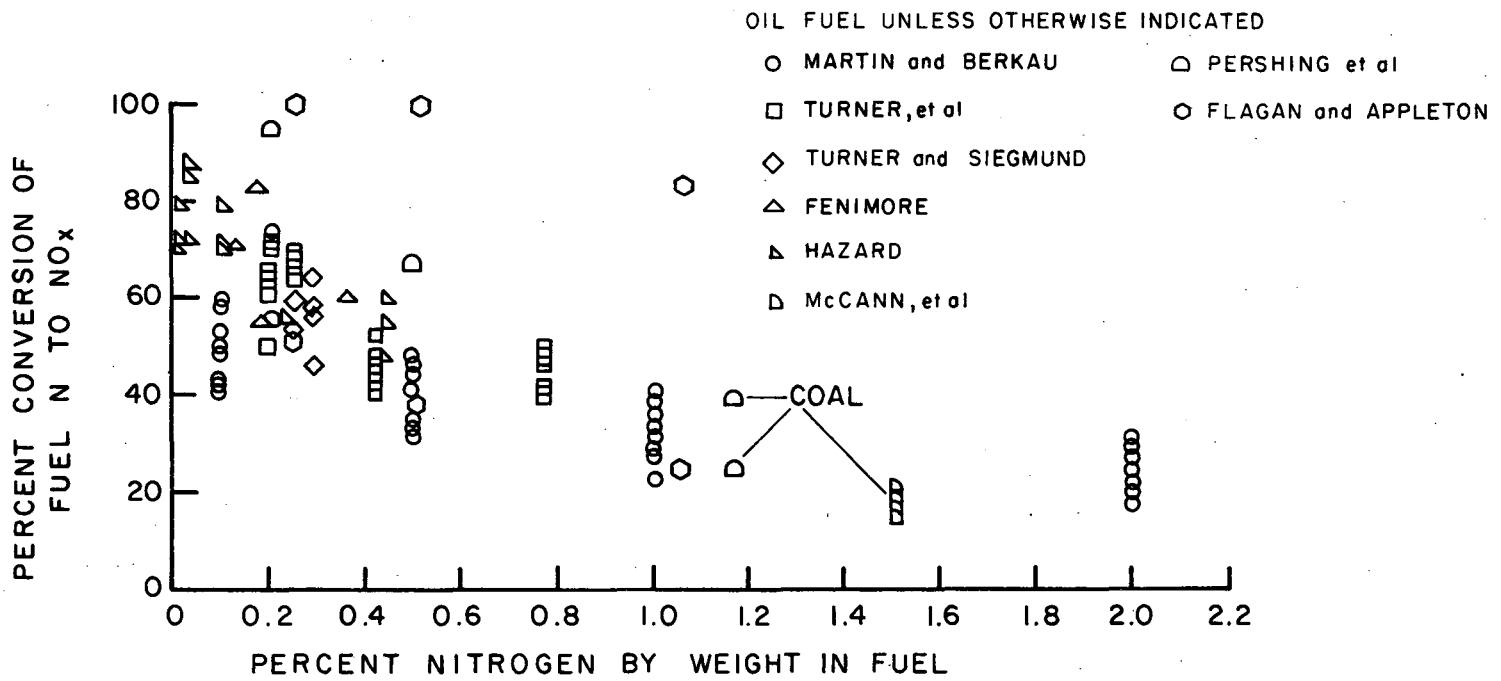

Figure 3-2. Relationship Between Fuel Nitrogen Concentration and Fraction Conversion to NO<sub>x</sub> (Sarofim and Flagan, 1976)

00104901092  
-85-

Recent studies have measured significant levels of  $N_2O$  in the emissions from power plants. Weiss and Craig (1976) report 25.8 ppm in the exhaust of a coal fired power plant and 25.0 ppm in the emissions from a plant fueled with fuel oil. This is in agreement with the data of Pierotti and Rasmussen (1976) who measured 32.7, 32.8, and 37.6 ppm of  $N_2O$  in the emissions from a coal fired power plant. In contrast, Pierotti and Rasmussen found only 3.1 - 11.0 ppm in the stackgases of power plants burning natural gas. This indicates that  $N_2O$  may be a significant product of fuel nitrogen combustion.

In summary, turbulent diffusion flame studies of fuel nitrogen chemistry have shown that the yield of NO may be decreased and the yield of HCN (and, presumably, other N-species) may be increased in turbulent diffusion flames as compared to premixed combustion systems. This is especially true under overall fuel rich conditions. The yield of NO decreases with increasing equivalence ratio and is very sensitive to mixing intensity. The fraction converted to NO either decreases or is independent of increasing fuel-N concentration. A significant portion of the fuel nitrogen may remain in the char during the combustion of coal.

#### 3.4 Models of the Fuel Nitrogen Conversion Mechanism

Several researchers have advanced models of the fuel nitrogen conversion mechanism in an attempt to predict exhaust NO. In general, these models suggest that the fuel nitrogen compound, FN, rapidly decomposes to produce an active intermediate, IN, such as HCN, CH,  $NH_3$ ,  $NH_2$ , NH, HNO, or N.



This active intermediate may then react in one of three ways:

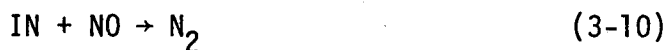

where RO is an oxygen containing species. It has been suggested that the actual process may take the form:

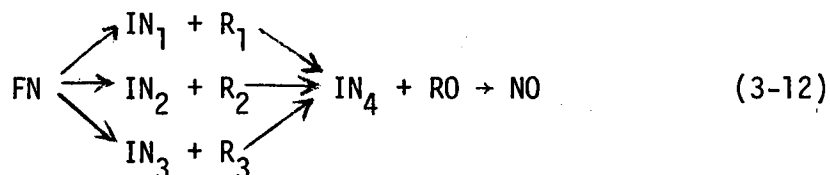

That is, the parent fuel nitrogen may decompose to form several species such as the HCN, NH<sub>3</sub>, NO and N<sub>2</sub> which were noted in the pyrolysis studies. These intermediates then react with other species to form IN<sub>4</sub>, the "indispensable intermediate." All of the NO produced from the fuel nitrogen is formed through this indispensable intermediate.

This indispensable intermediate is believed to be N by deSoete (1973, 1974). He determined kinetic rate coefficients for a global mechanism which modeled his data for addition of NH<sub>3</sub>, C<sub>2</sub>N<sub>2</sub>, and NO to C<sub>2</sub>H<sub>4</sub>/O<sub>2</sub>-Ar (or He) flat flames. Because of the uncertainties in the postulated mechanisms and the rate coefficients for many of the steps, Caretto (1976) agrees that N should be used in modeling efforts. In his model the fuel nitrogen would instantaneously dissociate to form N atoms, which would then form NO and N<sub>2</sub> via the Zeldovich mechanism:



Caretto prefers this model because it is the simplest possible model which predicts the correct trends.

Other researchers believe this indispensable intermediate is HCN. Leonard et al. (1976) have compared deSoete's model with data obtained from NH<sub>3</sub> addition to CH<sub>4</sub>/air combustion on a flat flame burner at 0.67 x 10<sup>5</sup> kPa. They found that deSoete's overall expression predicted their fuel NO formation rates within a factor of ten. However, they noted that a comparison of the HCN/CN partial equilibrium method with deSoete's overall rate suggested that HCN was the intermediate. In this case the NO formation step is



The model used by Leonard et al. uses twelve reactions to predict NO formation in which the reaction



is partially equilibrated, following the suggestion of Haynes et al. (1975) and Mulvihill and Phillips (1975). This approximate method was found to predict NO formation rates reasonably well. Haynes (1977a) notes that only HCN and NO leave the primary reaction zone of hydrocarbon/air flat flames doped with C<sub>5</sub>H<sub>5</sub>N, NH<sub>3</sub>, or NO. The N-H species are subsequently formed in the post flame zone. In Haynes (1977b) view, the decay of HCN in the post flame gases follows a mechanism corresponding to



The NH<sub>i</sub> species are formed via reactions such as



He then finds that if the  $\text{NH}_i$  system ( $i = 0, 1, 2, 3$ ) is internally equilibrated, the NO formation and removal reactions are



It should be noted that reaction (3-23) is the same as reaction (3-14) and reaction (3-22) is the third step in the extended Zeldovich mechanism.

It appears, then, that the extended Zeldovich mechanism may be the significant NO formation and removal reactions in the post flame zone. As noted by Sawyer et al. (1976) and Bowman (1976), the mechanisms for prompt NO and fuel NO in the flame zone are also similar. This indicates that prompt NO and thermal NO may be viewed as specialized cases of fuel NO. Or, it might be stated that NO formation from fuel nitrogen follows a prompt NO type mechanism in the combustion zone and an extended Zeldovich (i.e. thermal NO) type mechanism in the post flame zone.

### 3.5 Summary of Fuel Nitrogen Research

Several general conclusions may be drawn from the fuel nitrogen investigations which have been carried out to date. Bowman (1976) summarizes these as:

- 1) Oxidation of many nitrogen-containing compounds is rapid, occurring on a time scale comparable to that of the combustion reactions.
- 2) In the vicinity of the combustion zone, observed NO concentrations significantly exceed calculated equilibrium values.
- 3) In the post combustion zone, the NO concentration decreases, relatively slowly for fuel-lean mixtures and more rapidly for fuel-rich mixtures.
- 4) The NO yield is particularly sensitive to the fuel/air equivalence ratio. Relatively high yields are obtained for lean and stoichiometric mixtures; relatively low yields are found for rich mixtures.
- 5) NO yields are only slightly dependent on temperature, contrasting with the strong temperature dependence of NO formation from molecular nitrogen.

The following conclusions may be added to Bowman's summary:

- 6) Pyrolysis of fuels containing bound nitrogen and typical fuel nitrogen compounds generally produces low molecular weight nitrogenous species such as HCN,  $\text{NH}_3$ , NO,  $\text{NO}_2$ ,  $\text{N}_2\text{O}$ , and  $\text{N}_2$ .
- 7) The NO yield decreases with increasing fuel nitrogen concentration.
- 8) Decay of HCN, formation of  $\text{NH}_i$  species, and reactions governing NO concentrations in the post flame zone are very

sensitive to temperature. With decreasing temperature, HCN decays more slowly,  $\text{NH}_3$  builds up to higher concentrations and is more stable, and NO decays more rapidly.

- 9) The formation of HCN,  $\text{NH}_3$ , and other nitrogenous species (e.g.,  $\text{CH}_3\text{CN}$  and  $\text{CH}_2\text{CHCN}$ ) is promoted with increasing equivalence ratios.
- 10) The yield of NO may be decreased and the yield of HCN (and, presumably, other N-species) may be increased in turbulent diffusion flames as compared to premixed combustion systems.
- 11) The NO yield is sensitive to mixing intensity and, in practical combustion systems, may also be a function of residence time and temperature history.

## CHAPTER 4

### Other Sources of Nitrogenous Emissions

Investigations which have demonstrated that nitrogenous species (other than NO and N<sub>2</sub>) can be emitted from the combustion of fuels containing bound nitrogen were discussed in Chapter 3. Nitrogenous species are also emitted from sources which are not related to fuel nitrogen combustion. These sources may be generally classified into the following categories: previously unrecognized sources, new sources resulting from efforts to reduce air pollution, and non-combustion sources. This chapter will be devoted to a brief discussion of these sources.

#### 4.1 Previously Unrecognized Sources

Several combustion sources which have existed for a considerable time were not known to emit nitrogenous species until the last decade or so. For example, it has recently been demonstrated that HCN and other N-species may be a product of fires involving plastics (Gaskill, 1970; Wooley, 1972; Wagner, 1972; Gross et al., 1969). This in addition to the fact that a major proportion of municipal refuse is cellulosic, probably explains the results of a 1972 study (Carotti and Kaiser) which found small concentrations of cyanide in the flue gas of a municipal incinerator. Kaneko (1974) also found cyanide in concentrations of less than 1 ppm in incinerator emissions, but found that the levels could increase to 5 - 8 ppm under imperfect combustion

conditions. But these two previously unrecognized sources are probably not significant contributors to urban airborne loadings of N-species. On the other hand, there are some sources which may have been emitting significant amounts of N-species into the atmosphere for a long period of time.

a. Spark Ignition Engines

The most important example of a previously unrecognized source may be the automobile. Schuchmann and Laidler (1972) report that N-species other than  $\text{NO}_x$  may account for as much as 180 ppm of auto exhaust. Table 4-1 lists the nitrogenous species which have been identified in the emissions from spark ignition engines by various researchers.

Several studies have reported measuring HCN emissions from spark ignition engines. Although these studies found only 8 ppm in the exhaust, the tests were not intended to quantify peak HCN emissions and, therefore, were not carried out under the conditions which might be expected to yield the maximum concentration of HCN. Schuchmann and Laidler (1972) found slightly less than 1 ppm of HCN in the exhaust of a 1963 Ford Anglia which was operated under both rich and slightly rich conditions. Myerson and Blair (1976) found up to 8 ppm in the exhaust of a 1972 Ford 302 V8. This investigation will be discussed in more detail later in this chapter in the section dealing with air pollution control technology. Kaneko (1974) has measured cyanide in the exhaust from an automobile using a specific ion electrode. Cyanide concentrations (as HCN) ranged from 2 ppm at idle, to 5 ppm at 40 km/hr, 10 ppm at 60 km/hr, and 15 ppm at 80 km/hr. As discussed in the next section, a catalytic converter reduced CN emissions by 50-90%.

TABLE 4-1

Nitrogenous Emissions from Spark Ignition Engines

Seizinger and Dimitriades (1972)

Phenyl Cyanide

Nitromethane

Schuchmann and Laidler (1972)

Hydrogen Cyanide

Methyl Cyanide

Ammonia and Lower Amines

Bellar and Sigsby (1970)

Methyl Cyanide

Vinyl Cyanide

Ethyl Cyanide

Methyl Nitrate

Nitromethane

Hurn, Alsup, and Cox (1974, 1975)

Hydrogen Cyanide

Cyanogen (unconfirmed)

Nitromethane

Ammonia (unconfirmed)

Lampe and Deichmann (1964)

1-nitro-2-methyl-1-propene

1-nitro-2-methyl-2-propene

Miscellaneous

Cyanides (Kaneko, 1974)

Ammonia (Harkins and Nicksic, 1967)

Alkylamines (Haagen-Smit, private communication with Schuchmann and Laidler, 1972)

Nitrosamines (Fine et al., 1976)

3-nitro-2-methyl-2-butene (Wasserberger et al., 1970)

3-nitro-3-hexene (Lampe and Deichmann, 1965)

Hydrogen Cyanide (Myerson and Blair, 1976)

Hurn et al. (1975, 1976) detected 1 to 1.5 ppm of HCN in the exhaust of 3 1972 Chevrolet vehicles and 2 stationary 1972 Chevrolet engines. Emissions of HCN and other species were not affected by gasoline additives. Gabele et al. (1977) report average HCN emissions from a Honda CVCC as  $11.5 \pm 2.0$  mg/mi over the 1975 Federal Test Cycle. Chrysler vehicles with lean-burn engines emitted  $10.7 \pm 1.6$  mg/mi of HCN.

Other nitriles identified in automotive exhaust are cyanogen, phenyl cyanide, methyl cyanide, vinyl cyanide, and ethyl cyanide. Cyanogen was measured by Hurn et al. (1975, 1976) in the investigations just reviewed. Seizinger and Dimitriades (1972) identified but did not quantify phenyl cyanide in the exhaust of a 1970 Ford 170 CID 6 cylinder which was operated over the seven-mode California driving cycle. Methyl cyanide, ethyl cyanide, and vinyl cyanide were detected by Bellar and Sigsby (1970) using direct gas chromatography. Methyl cyanide was also detected by Schuchmann and Laidler (1972).

Harkins and Nicksic (1967) measured between 1 and 6 ppm of  $\text{NH}_3$  in the exhaust of a 1956 Oldsmobile V8 which was operated over the California Motor Vehicle Pollution Control Board Cycle. Based on these measurements, they calculated that auto exhaust could account for 10% of urban atmospheric  $\text{NH}_3$ . The engine used did not have an emissions control system. The presence of nitrogen-containing detergent additives or lead antiknock compounds in the fuel did not affect the  $\text{NH}_3$  levels in the exhaust. A wet chemical method was used for ammonia quantification. Schuchmann and Laidler (1972) measured levels of  $\text{NH}_3$  and lower amines as high as 180 ppm for slightly rich combustion and 60 ppm for rich combustion. They used a wet chemical technique to analyze the exhaust from a 1963 Ford Anglia. They also report that Haagen-Smit detected alkylamines in auto exhaust. However, in a recent study, Dietzmann (1975) failed to detect  $\text{NH}_3$  in the exhaust of a 1972 and

a 1975 350 CID Chevrolet V8 engine. These engines were operated using the 1975 Light Duty Federal Test Procedure and four different fuel additive combinations were tested. The 1975 V8 was equipped with an exhaust gas recirculation system, an air pump, and an exhaust purification catalyst. One possible explanation for the failure to detect  $\text{NH}_3$  results from the method of taking bag samples of the diluted exhaust. Ammonia and other amines are noted for their tendency to adsorb on surfaces, and any  $\text{NH}_3$  in the exhaust in this test may have adsorbed to the bag surface. Measurement of  $\text{NH}_3$  was attempted using a GC with a Hall Electrolytic Conductivity detector. A Teflon column with Ascarite packing was operated at room temperature. Myerson and Blair (1976) also were unable to detect  $\text{NH}_3$ . They used a 1972 Ford 302 V8 but did not give details of the sampling and analysis techniques which were employed. Hurn and coworkers (1975, 1976) tentatively detected  $\text{NH}_3$  in the exhaust of 5 1972 Chevrolets and 1973-1974 models (one Ford, one Chevrolet, one Volkswagen, and two Mazda rotarys). Because of an interference peak, they were unable to confirm the presence of  $\text{NH}_3$ . The reasons for lack of agreement among the various researchers is unclear and merits further investigation.

Fine et al. (1976) are the sole researchers who have detected nitroso compounds in auto exhaust. Several other researchers have unsuccessfully attempted to detect these carcinogens in the emissions from automobiles (Hurn et al., 1975, 1976; Dietzman, 1975; Lestz, 1975). However, none of these researchers used the analytical technique used by Fine et al. There is concern that the nitrosamines were formed in the sample concentration process, but even this would indicate the presence of precursors. The other investigators also failed to detect

these precursor amines, which might indicate some difficulty with the sample transfer or analytical systems. Recall that other researchers have observed amines (Schuchmann and Laidler, 1972; Haagen-Smit as reported by Schuchmann and Laidler; Harkins and Nicksic, 1967). The lack of agreement among these researchers emphasizes the difficulties in the quantitative analysis of amines in combustion products. Considering the significance of these species, further research is warranted.

Seizinger and Dimitriades (1972) measured as much as 5 ppm of nitromethane in the exhaust of a 1970 Ford 170 CID 6 cylinder Maverick which was operated over the seven-mode California driving cycle. Dietzmann (1975) reports nitromethane levels between approximately 0.1 and 0.5 ppm. Fuel/additive combination, engine configuration, and exhaust treatment did not significantly affect exhaust nitromethane concentrations. Bellar and Sigsby (1970) also detected nitromethane and methyl nitrate in auto exhaust. Hurn et al. (1975, 1976) measured 0.2 - 0.3 ppm of nitromethane in auto exhaust and found that exhaust levels were not affected by the use of a nitrogen containing gasoline additive.

Nitro olefins have been identified in the exhaust of spark ignition engines by several different researchers. Wasserberger et al. (1970) identified 3-nitro-2-methyl-2 butene in the exhaust of a single cylinder four stroke engine which was fueled with 2-methyl-2-butene, the principal olefin in a premium grade gasoline. This same nitro olefin was tentatively identified in the exhaust of a gasoline fueled, 36 horsepower Volkswagen engine during the same investigation. Lampe and Deichmann (1964) investigated the combustion of isobutylene in a

single cylinder, 4 cycle engine. They detected both the conjugated nitro olefin, 1-nitro-2-methyl-1-propane, and the nonconjugated nitro olefin, 1-nitro-2-methyl-2-propane, in the engine exhaust. In a similar experiment, they found 3-nitro-3-hexene and its nonconjugated tautomer in the exhaust when 3-hexene (a normal constituent of gasoline) was the fuel. Stephens and Price (1965) report the tentative identification of nitroethylene and 1-nitro-1-propane in the exhaust of a truck fueled with 1-nitro-1-propane.

b. Compression Ignition Engines

Apparently, very little work has been done in characterizing nitrogenous emissions, other than  $\text{NO}_x$ , from compression ignition engines. Hilliard and Wheeler (1974) report measuring significant concentrations of  $\text{NO}_2$  in diesel exhaust. Braddock and Bradow (1975) found that the  $\text{NO}_2/\text{NO}_x$  ratio in the emissions from a light duty diesel was as high as 27.6% at idle, 16.3% at 30 mph, and 9.1% at 50 mph. This is a much higher  $\text{NO}_2$  emission rate than is exhibited by a comparable spark-ignition automobile. Braddock and Gabele (1977) measured HCN emissions from a diesel powered passenger car. The levels ranged from 0.37 - 1.91 mg/mi, depending on the fuel (Jet A, Local No. 1, national average No. 2, or No. 2-D) and the test cycle (1975 Federal Test Procedure, Highway Fuel Economy Test or Sulfate Emissions Test procedure). However, HCN emissions were lower than for stratified charge, lean-burn, or dual catalyst cars over the same cycle. Fine et al. (1976) report measuring N-nitroso compounds in diesel exhaust. Because of their advantageous fuel consumption characteristics, diesels are becoming more and more popular as engines for passenger cars and light duty trucks. For this reason, research into emissions of N-species from diesel engines should be expanded.

c. Gas Turbines

Two categories of research into emission of N-species from gas turbines will be discussed. The first reveals the emission of organic N-species, primarily methyl cyanide and nitromethane, from gas turbines. Secondly, and of more potential importance, is the observation of significant emissions of  $\text{NO}_2$  from commercial gas turbines.

Table 4-2 lists the N-species measured in a series of studies by Stumpf and Blazowski (1976), Conkle et al. (1976), Sievers et al. (1976), and Roquemore and Hodgeson (1976). These investigations were discussed in section 3.3. Several fuels and two additives were tested in a T56 Series III A single combustor. Six of these combustors, annularly arranged, form the basis of the T56 turboprop engine which is used in the C-130 aircraft. The test facility allowed the simulation of high power operation and the attainment of idle at several different pressure ratios to simulate the operating conditions of other engines. Two factors about the analysis for the N-species should be noted. 1) Analysis was by GC-MS and GC-FID, both using a Porapak Q column. Other studies have indicated difficulty in measuring low concentrations of HCN with this column. Stumpf and Blazowski (1976) state that the "data do not include significant amounts of HCN, contrary to expectations." This may be due to HCN adsorbing on the Porapak Q. Therefore, the results may not be the "percent of total organics which are nitrogenous" but rather the "percent of organics other than HCN which are nitrogenous." 2) The data were quantified on a hexane equivalent basis. That is, the peak area/ppm ratio was derived from a 113 ppm hexane peak. The sensitivity to other hydrocarbons will differ

TABLE 4-2

Nitrogenous Emissions from Gas Turbines  
(from the data of Conkle et al., 1976)

<u>Identified</u>	<u>Tentatively Identified</u>
Methyl Cyanide	Ethyl Cyanide
n-Valeronitrile	Pyrazole
Glycolonitrile	2-Ethyl-1-Diazridine
Nitromethane	
neo-Pentyl Nitrate	
Imidazole	
2,4-Dimethyl Inidazoline	
3,6-Dipropyl-1,2,4,5-Tetrazine	
2-Methyl-2-Nitropropane	
$\beta$ -Keto-1-Nitro Octane	

from that for hexane especially when a Flame Ionization Detector is used for analysis, since the FID signal is proportional to the number of hydrocarbon bonds of the species being measured. Therefore, the quantification of the N-species is rather gross in nature and the error limits may be quite large.

Table 4-3 shows the experimental conditions which were investigated and how they affected the fraction of the organic emissions which were attributable to nitrogenous species. The most obvious trend is that the fraction increases markedly with increasing combustor inlet pressure (pressure ratio). Secondly, the fuel type can affect the fraction when all other conditions remain constant. Results for JP4, JP5, and iso-octane are comparable under mid-pressure ratio idle conditions, but are down by a factor of 5 or 6 for JP8 under the same conditions. Fuel additives also have an impact on the fraction which is nitrogenous. Addition of 0.042 wt. % of ferrocene (an iron containing additive) to JP5 at 75 psig can decrease the fraction which is nitrogenous by more than 50%. Addition of 1.68% pyridine (a nitrogen containing additive) to JP4 at 33 psig increases the fraction which is nitrogenous by more than a factor of 3. This last observation is discussed further in section 3.3. Therefore, the fraction of the organics (other than HCN) which is attributable to N-species increases with increasing pressure and is effected by fuel and additive type.

Table 4-4 details the distribution of nitrogenous organics among the various N-species which were measured. Methyl cyanide and nitromethane were the species most commonly measured, although other species were important in some instances. It should be noted that the actual

TABLE 4-3

Percent of Organic Gas Turbine Emissions which Contain Nitrogen\*

FUEL	JP4	JP4	JP4	JP4	JP8	Iso octane	JP5	JP5
ADDITIVE	---	---	---	1.68 wt % pyridine	---	---	---	0.042 wt % ferrocene
PRESSURE (psig)	15	33	50	33	33	33	75	75
COMBUSTOR INLET TEMPERATURE (°K)	367	439	478	439	438	439	627	627
COMBUSTOR INLET PRESSURE (psig)	2.0	3.2	4.4	3.2	3.2	3.2	6.0	6.0
FUEL/AIR WT. RATIO	.0078	.0076	.0080	.0075	.0075	.0078	.0179- .0188	.0183- .0191
CONDITION	LowPR/dle	MidPR/dle	HiPR/dle	MidPR/dle	MidPR/dle	MidPR/dle	High Power	High Power
N/HC (%)	0.1	2.0	5.5	6.5	0.4	2.5	5.4	2.1

\* from the data of Stumpf and Blazowski (1976)

TABLE 4-4  
 Distribution of Nitrogenous Species in Gas Turbine Exhaust  
 (from data reported by Conkle et al., 1976)

Fuel	JP4	JP4	JP4	C <sub>8</sub> H <sub>18</sub>	C <sub>8</sub> H <sub>18</sub>	JP4	JP4	JP8	JP5**	JP5	JP5
Additive	---	---	---	---	---	Pyri- dine	Pyri- dine	---	---	Ferro- cene	Ferro- cene
Pressure (psig)	15	33	50	33	33	33	33	33	75	75	75
Total N-Species (ppm as Hexane)	.0319	.0743	.0328	.005	.0103	.0374	.0407	.0119		.0008	.039
Distribution											
Methyl Cyanide	43.89	98.25	14.63		25.24	5.61	5.16	17.65	37.78		10.26
Glycolonitrile			3.05								
n-Valeronitrile			0.61								
Nitromethane	15.36		8.54	100.0	33.01	29.41	41.77	72.27	18.41	100.0	89.74
Imidazole	40.75					56.15					
neo-Pentyl Nitrate			73.17								
β-Keto-1-Nitro Octane		1.75									
2,4-Dimethyl Inidazoline							46.68				
3,6-Dipropyl-1,2,4,5- Tetrazine					41.75	6.42					
2-Methyl-2-Nitro Propane									43.81		
(Ethyl Cyanide)*						2.41					
(Pyrazole)							6.39				
(2-Ethyl-1-Diazridine)								10.08			

\*brackets indicate tentative identification

\*\*average of 3 points

00004901101

concentrations of these species are very low, partially due to the diluent effect of the secondary cooling air in gas turbines. The main significance of this series of studies is that it emphasizes that complex nitrogenous species can be formed in commercial combustion systems, even those that are operated under very fuel lean conditions. This is most probably attributable to the nature of the turbulent diffusion flame, and the same emissions characteristics may not be expected for premixed, fuel-lean combustion systems.

Until the early 1970's, it was generally accepted that  $\text{NO}_2$  constituted, at most, 5% of the total oxides of nitrogen in the emissions from gas turbines (Heywood et al., 1971; Fletcher et al., 1971; Mellor, 1972). In late 1971, Airesearch Manufacturing Company reported measuring significant concentrations of  $\text{NO}_2$  in the exhaust of gas turbines of their manufacture. A portion of these measurements are shown in Figure 4-1. Matthews (1972) measured the distribution of oxides of nitrogen in a model gas turbine combustor (Figure 4-2) and confirmed that levels well above previously reported results and equilibrium predictions could be detected. There was much concern that the  $\text{NO}_2$  was an artifact of the sample transfer system, and investigations of this problem are discussed in section 6.5. It is now fairly widely acknowledged that high  $\text{NO}_2/\text{NO}$  ratios may be a characteristic of gas turbines and many other lean turbulent diffusion combustion systems (Mellor, 1976; Noguchi et al., 1976). Emissions of  $\text{NO}_2$  are significant because emission of  $\text{NO}_2$  rather than  $\text{NO}$  will affect the induction period for photochemical smog formation and may increase ambient  $\text{NO}_2$  concentrations near sources.

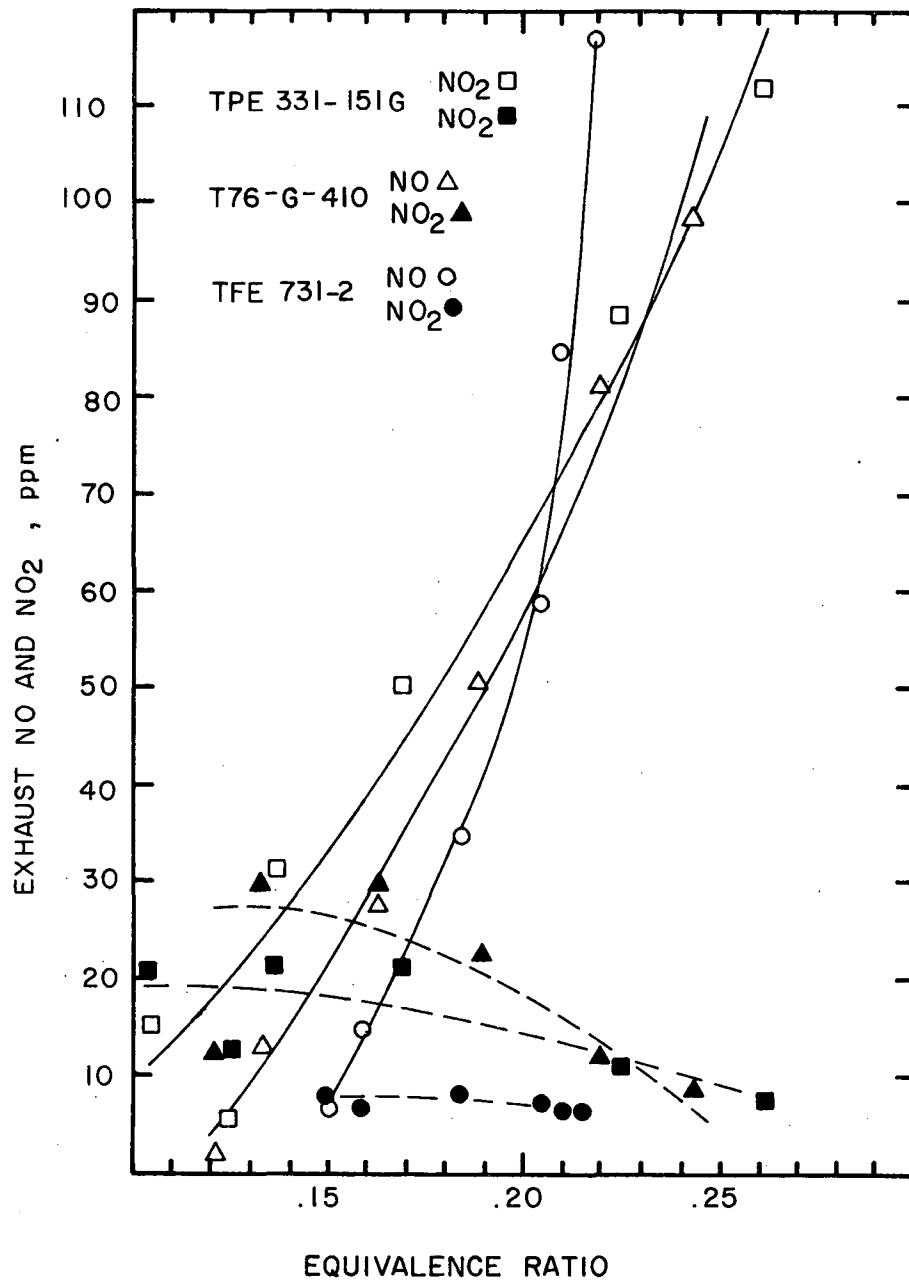

Figure 4-1. Emissions of NO and NO<sub>2</sub> from Commercial Gas Turbines as a Function of Equivalence Ratio (Airesearch, 1971)

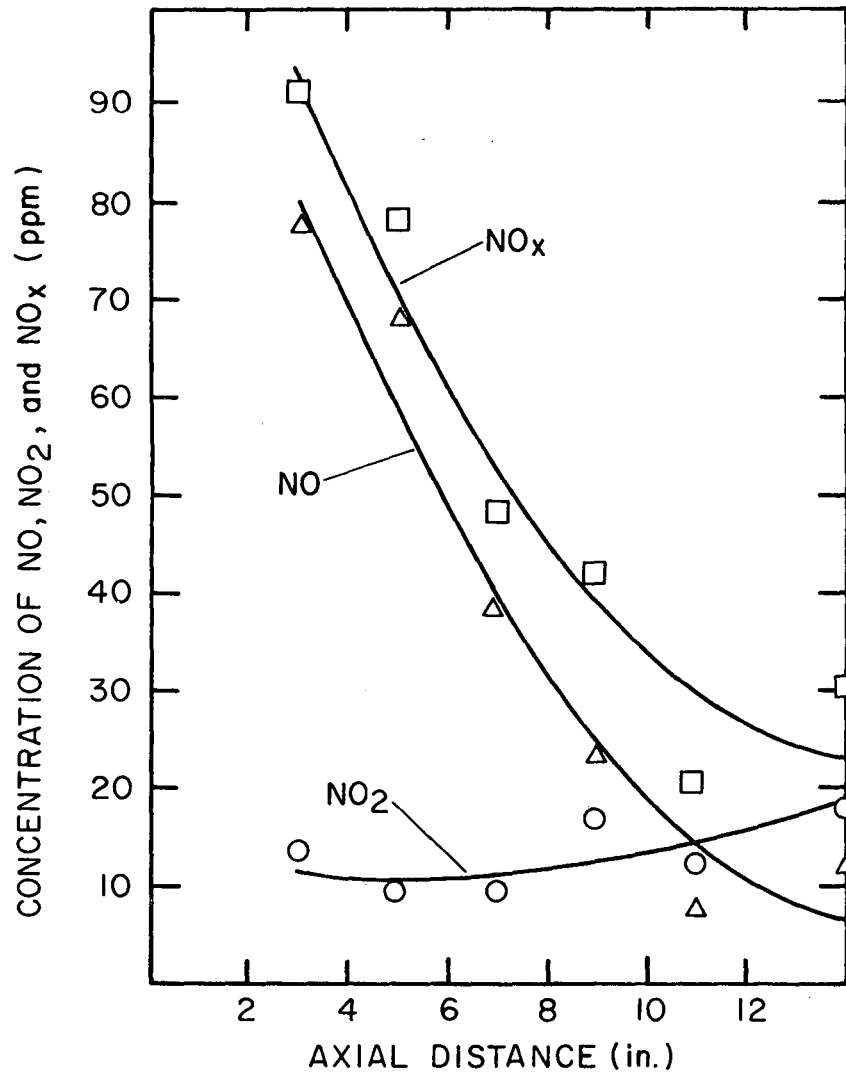

Figure 4-2. Centerline Axial Distribution of NO, NO<sub>2</sub>, and NO<sub>x</sub> in a Model Gas Turbine (Matthews, 1972; Schefer et al., 1973)

#### d. Power Plants

Power plants are among the most obvious candidates for use of fuels containing bound nitrogen rather than natural gas. The switch to coals and residual fuel oils is well under way. This is one of the reasons why there are very few studies of nitrogenous emissions from power plants fueled with natural gas. However, there are a significant number of power plants still using natural gas and knowledge of their nitrogenous emissions is useful not only for its own sake but also because it allows a more accurate assessment of the impact of fuel nitrogen through comparison and contrast. The few studies which have been done will be discussed in the following paragraphs.

Pierotti and Rasmussen (1976) have recently measured  $N_2O$  in the stack gases from power plants burning coal and natural gas. They measured  $N_2O$  concentrations of 3.1 and 11.0 ppm in the exhaust of two power plants operating on natural gas. (Emissions from coal-fired plants were an order of magnitude higher. See 3.3). The  $N_2O$  formation mechanism was previously suggested by Pratt and Malte (1975). They propose that the reaction



is important in combustion processes at temperatures which are lower than  $1800^\circ$  K. In fact, this reaction may be important in other commercial combustion devices, but measurements have only been attempted on one other combustion system: the spark ignition engine. In the same study, Pierotti and Rasmussen report measuring 100 - 200 ppb of  $N_2O$  in auto exhaust. Because this is lower than ambient levels, it is not cause for concern. However, it has been shown (Weiss and Craig, 1976)

that automotive exhaust purification catalysts can increase  $N_2O$  emissions by several orders of magnitude. This will be discussed in section 4.2.b.

Kaneko (1974) reports that emissions of cyanides from the stack of a "general" boiler were below the detectable limit ( $\sim 0.5$  ppm) of an ion electrode. It is not clear whether this was a power plant or another type of boiler. However, it is not expected that emissions of cyanides or amines (other than  $NH_3$ ) from power plants would be significant. Power plants are operated under fuel-lean conditions. More importantly, the residence time in the high temperature region of a power generation boiler is very long. For this reason, emissions of unburned hydrocarbons from power plants are very low. Cyanides and alkylamines contain hydrocarbon groups and, therefore, emissions of these species from power plants should also be low. Table 4-5 shows that in 1970 emissions of hydrocarbons from stationary sources constituted only 1.7% of total HC emissions. In contrast, stationary sources contributed 43.8% of nationwide  $NO_x$  emissions.

e. Experimental Laboratory Combustion Devices and Miscellaneous Industrial, Commercial, and Domestic Combustion Systems

Studies of emissions from laboratory combustion systems can be used to infer potential emissions from commercial combustion devices.

$NO_2$  has been measured in the emissions of many laboratory combustion systems. These investigations are discussed in detail in section 6.1. In general, it has been observed that  $NO_2$  is formed in fuel lean premixed flames or in the cooler regions of turbulent diffusion flames. Survival of  $NO_2$  into the post flame gases depends on several factors such as residence time and temperature history.

TABLE 4-5. Nationwide Source Emissions of Hydrocarbons, 1970  
(Cavender et al., 1973)

Source Category	Emissions 10 <sup>6</sup> tons/yr	Percent of Total
Transportation	19.5	55.9
Motor vehicles	16.7	47.9
Gasoline	16.6	47.6
Diesel	0.1	0.3
Aircraft	0.4	1.1
Railroads	0.1	0.3
Vessels	0.3	0.9
Nonhighway use of motor fuels	2.0	5.7
Fuel combustion in stationary sources	0.6	1.7
Coal	0.2	0.6
Fuel oil	0.1	0.3
Natural gas	0.3	0.8
Wood	Neg <sup>a</sup>	---
Industrial process losses	5.5	15.8
Solid waste disposal	2.0	5.7
Agricultural burning	2.8	8.0
Miscellaneous	4.5	12.9
Forest fires <sup>b</sup>	0.3	0.9
Structural fires	0.1	0.3
Coal refuse burning	0.1	0.3
Gasoline and solvent evaporation	4.0	11.4
<b>TOTAL</b>	<b>34.9</b>	

<sup>a</sup>Negligible (less than  $0.05 \times 10^6$  tons/year).

<sup>b</sup>Includes prescribed burning.

Investigations into the "prompt NO" mechanism have revealed that HCN, in relatively high concentrations, is formed in premixed fuel rich combustion systems (Eberius, 1972; Bachmaier et al., 1973; Haynes et al., 1974; Haynes, 1975; Takagi et al., 1977; Blauwens et al., 1977, Miyauchi et al., 1977; Malte et al., 1976; Morley, 1976). Some of these studies also noted small quantities of NH<sub>3</sub>. This is an indication that HCN and NH<sub>3</sub> formed in the fuel rich region of a turbulent diffusion flame may be emitted as a stable product, under certain conditions. In fact, several studies have shown this to be the case. A study by Takagi et al. (1977) demonstrated that several hundred ppm of HCN could be emitted from turbulent diffusion flames even without the addition of a model fuel nitrogen compound. Yamagishi et al. (1974) showed the same effect in a two stage combustion system. A series of studies on gas turbines had the unexpected result that, even in this very fuel lean combustion system, as much as 5.5 percent of the unburned hydrocarbons were nitrogenous (see section 4.1.c).

Fenimore (1971) proposes that "prompt NO" is formed in fuel rich premixed flames via the reactions



Takagi et al. (1977) include the reaction



and note that in turbulent diffusion flames hydrocarbon fragments survive much longer than in the corresponding premixed case. This results in effectively higher concentrations of CH and CH<sub>2</sub> in the diffusion flame case. They suggest that this may be responsible for

the "higher HCN formation in the turbulent diffusion flames than in the premixed flames." This is an important observation because turbulent diffusion flames are the basis for the vast majority of commercial, industrial, and domestic combustion systems.

The results of Takagi and co-workers agree with those reported by Yamagishi et al. (1975). Staged combustion was studied in a system which allowed continuous variation of the primary zone fuel/air mixture from completely premixed to a conventional turbulent diffusion flame. They found that formation of HCN,  $\text{NH}_3$ , and even NO under fuel rich conditions was dependent on how premixed the primary combustion zone was. As seen in Figure 4-3, these N-species were emitted from the primary combustion zone at maximum concentrations in the turbulent diffusion flame mode with decreasing levels as the  $\text{CH}_4$  and air became more and more premixed. Total  $\text{NO}_x$  in the exhaust followed a similar pattern. However, a chemiluminescent analyzer was used for total  $\text{NO}_x$  analysis, a method which has since come under question (see section 6.2.d).

There are a large number of combustion systems for which there have been no reported measurements of nitrogenous emissions. Whether species such as  $\text{NO}_2$ ,  $\text{N}_2\text{O}$ , HCN, and  $\text{NH}_3$  are emitted may be a function of fuel type, mixing intensity, residence time, and temperature history. Experimental observations referenced in this chapter and in Chapter 3 indicate that a real potential exists for emissions of nitrogenous species from these combustion systems. Assumptions that these species are not present should no longer be considered to be valid.

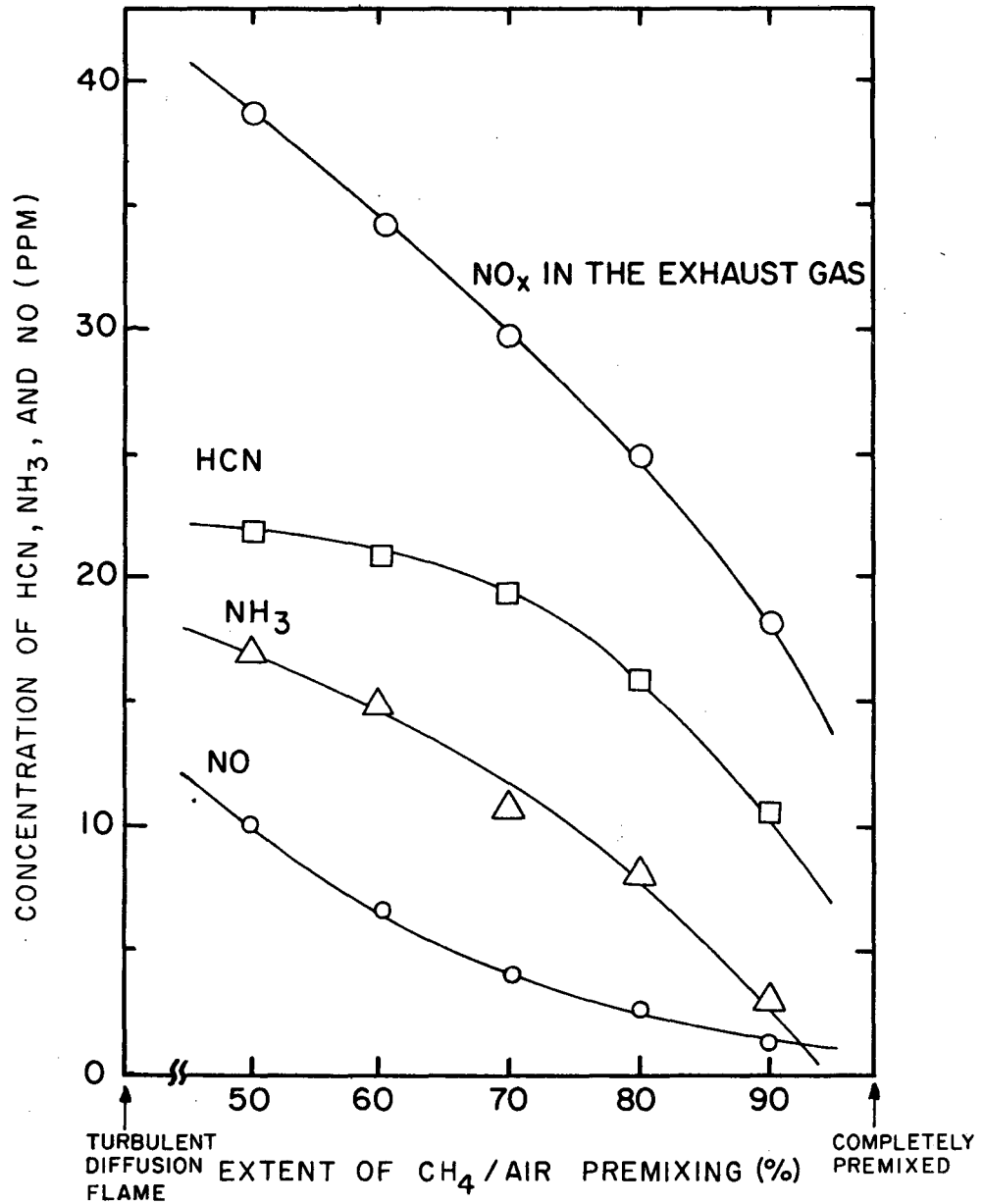

Figure 4-3. Effect of Extent of Fuel/Air Premixing on Formation of HCN, NH<sub>3</sub>, and NO in the Fuel Rich Primary Stage of a Two Stage Combustion System. Also shown is the effect on NO<sub>x</sub> emissions from the second stage (Yamagishi et al., 1974)<sup>x</sup>

## 4.2 Air Pollution Control Technology

Ironically, air pollution control technology may increase the emission of nitrogenous species. Regulations of  $\text{NO}_x$  emissions may result in control strategies which may inadvertently promote the production of HCN,  $\text{NH}_3$ ,  $\text{N}_2\text{O}$ , or other unregulated nitrogenous species. Control strategies may be classified as either heterogeneous or homogeneous exhaust clean-up or combustion modification. Combustion modification for control of  $\text{NO}_x$  was discussed in Chapter 2. Exhaust after-treatment will be discussed in the following paragraphs.

### a. Heterogeneous Techniques

Exhaust purification catalysts are widely used to promote oxidation of CO and unburned hydrocarbons in automotive exhaust. A variation may be used in the near future to reduce  $\text{NO}_x$  emissions. The CO and UHC catalysts are designed to operate under oxidizing conditions, but under some circumstances (such as deceleration or downhill coasting), automotive exhaust is a reducing mixture. Under these conditions, it has been shown (Barnes and Summers, 1975) that  $\text{H}_2\text{S}$  can be formed from exhaust  $\text{SO}_2$  in the presence of a catalyst. Furthermore, Voorhoeve et al. (1975) have demonstrated that as much as 80 ppm of HCN can be formed during passage over a model catalyst of a  $\text{CO}/\text{NO}/\text{H}_2/\text{H}_2\text{O}/\text{SO}_2/\text{He}$  mixture. The production of HCN decreases as the added  $\text{SO}_2$  increases, but under these conditions  $\text{H}_2\text{S}$  is formed. Voorhoeve et al. also noted the formation of what was tentatively identified as dimethylamine,  $(\text{CH}_3)_2\text{NH}$ . Emissions of HCN and  $\text{H}_2\text{S}$  can be minimized by the addition of  $\text{O}_2$  to the exhaust upstream from the catalyst. In fact, Kaneko (1974) has found that a catalytic converter can remove 50 - 90% of the cyanide emissions

normally found in auto exhaust (see 4.1.a). Therefore, it is probable that cyanide emissions from vehicles with oxidation catalysts are not significant except on cars not equipped with air pumps and those with malfunctioning systems. However, it is possible that the observed HCN formation can occur over NO reduction catalysts because, in this case, there is not enough free oxygen available to inhibit the HCN formation reactions. Braddock and Gabele (1977) report an EPA study which measured HCN emissions from a prototype dual-catalyst car. The emission levels ( $4.44 \pm 2.67$  mg/mi) were approximately one-half of that exhibited by lean-burn vehicles or stratified charge engine cars, but were more than twice the HCN emissions exhibited by light duty diesels.

As previously mentioned, two types of automotive catalytic converters are currently being used or may be used in the near future. Oxidation catalysts remove CO and UHC's from auto exhaust and reduction catalysts remove NO. Seinfeld (1975) suggests that  $N_2O$  may be formed over oxidation catalysts via the overall reaction

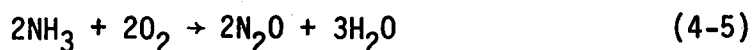

Otto et al. (1970, 1971) have found four overall reactions describing the operation of reduction catalysts:

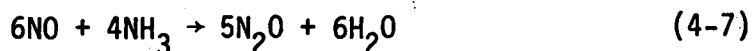
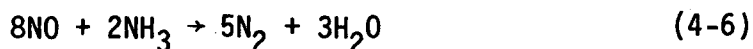

They report that platinum catalysts which are the type being used commercially, exhibit a 45% conversion of NO to  $N_2O$ . Voorhoeve et al. (1973) have studied the effect of catalyst material on NO reduction. Of the 13 rare-earth manganites studied, only one demonstrated 100% conversion

of NO to N<sub>2</sub>. The rest evidenced the production of either NH<sub>3</sub> (up to 50% of the inlet NO) or N<sub>2</sub>O (up to 70%). Lee and Makowski (1974) have demonstrated that NH<sub>3</sub> is an active intermediate in NO removal over NO reduction catalysts. Substantial emission of NH<sub>3</sub> may occur at high inlet NO, low inlet O<sub>2</sub>, and high inlet H<sub>2</sub>. In addition to reactions (4-6) and (4-9), they offer

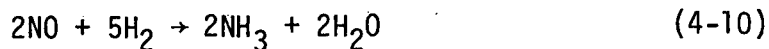

as reactions of significant importance. Pierotti and Rasmussen (1976) found that a catalytic converter could increase N<sub>2</sub>O emissions by as much as a factor of 10 with levels up to 1 ppm being observed. Weiss and Craig (1976) report a personal communication from Cicerone who measured N<sub>2</sub>O emissions up to 10 ppm from 1976 cars equipped with platinum-paladium catalysts. Weiss and Craig predict that emissions as high as 400 ppm are possible from reduction catalysts. Using this value they calculate that N<sub>2</sub>O emissions from catalytic converters could reach 3.3 MT/year. This is of the same order as their calculated value for the combustion of coal and fuel on 2.0 MT/year (Pierotti and Rasmussen estimate that coal combustion contributes 3.5 MT/year). Even without the contribution from exhaust catalysts, Weiss and Craig calculate that combustion sources of N<sub>2</sub>O can explain up to 50% of the observed increase in atmospheric nitrous oxide. Woolsey (1977) reports preliminary findings that average N<sub>2</sub>O emissions from vehicles passing through the tunnel under Boston Harbor are less than 60 ppb or 64 mg/mi. The traffic mix in this study does not contain many catalyst-equipped vehicles.

Three way exhaust catalysts are rapidly cycled from slightly lean to slightly rich. Emissions of CO, UHC's, and NO can be simultaneously reduced using this apparatus. However, no reported research has studied

the emission of other nitrogenous species from these systems. The potential exists for emission of these species, especially  $N_2O$  and  $NH_3$ . Further research is advisable.

b. Homogeneous Techniques

Control of  $NO_x$  emissions by gas phase chemical reactions has been proposed for both automotive and industrial applications.

Two studies aimed at promoting the conversion of  $NO_x$  to  $N_2$  found that injection of a hydrocarbon-oxygen mixture into auto exhaust worked well under optimum conditions. However, one of the studies found that retarding the spark timing by just  $4^\circ$  could increase the HCN emission by an order of magnitude to 125 ppm (Myerson and Blair, 1976). The other investigation revealed that NO and hydrocarbons could react heterogeneously with the metallic components of the exhaust system to form HCN (Pozniak, 1975). A similar investigation (Wendt et al., 1973) which proposed secondary fuel injection to reduce  $NO_x$  emissions from power plants found that injection of methane could reduce  $NO_x$  by 50% and injection of ammonia could decrease  $NO_x$  emissions by as much as 90%.

Muzio et al. (1977) and Exxon (1977) have confirmed these findings using  $NH_3$ ,  $H_2$ , and various hydrocarbons as secondary fuels. However, it has been pointed out (Myerson, 1975) that hydrocarbon injection could work through reactions such as

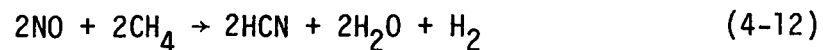

Muzio et al. found that cyanide emissions were less than 1 ppm when  $NH_3$  was the secondary fuel. However, in the Exxon Thermal Denox Process (U.S. Patent 3,900,554),  $H_2$  or  $CH_4$  may be injected with the  $NH_3$  for temperature compensation. With  $CH_4/NH_3$  injection a few ppm of HCN can

be emitted. Emissions of  $\text{NH}_3$  can be kept to about 10 ppm under optimum conditions, but exhaust  $\text{NH}_3$  may be much higher under off-design operation. Between 1 and 2 moles of  $\text{N}_2\text{O}$  may be formed for every 100 moles of  $\text{NO}$  removed. This would constitute a source of  $\text{N}_2\text{O}$  of 0.3 Mtons/year for the application of this process to all stationary sources. Ammonia injection is currently being considered for application to diesels also.

A unique method of smog control has been investigated by Jayanty et al. (1974) and Stockburger et al. (1975). They suggest that adding 0.03 - 0.5 ppm of N, N'-diethylhydroxylamine (DEHA,  $(\text{C}_2\text{H}_5)_2\text{NOH}$ )-- to polluted urban air would inhibit formation of  $\text{O}_3$  and would also inhibit the conversion of  $\text{NO}$  to  $\text{NO}_2$ . They base this suggestion on experiments involving ethylene, propylene, DEHA, and  $\text{NO}_x$  at concentrations of several ppm. They claim that the only byproducts formed which are not already present in the air are ethanol and nitroethane ( $\text{C}_2\text{H}_5\text{NO}_2$ ). However, Pitts et al. (1977) have studied the effect of DEHA on actual urban air and found that it enhanced the formation of  $\text{O}_3$ , peroxyacetyl nitrate (PAN), and  $\text{NO}_2$ . They did confirm that DEHA could inhibit  $\text{O}_3$  and  $\text{NO}_2$  formation when introduced at 2.0 ppm but this is above the odor threshold of DEHA, 0.5ppm. Furthermore, they point out that this control method may simply slow the photochemical reactions so that downwind areas would be more heavily affected. The toxicity of DEHA is still being studied.

#### 4.3 Interaction of the Air Pollution and Energy Problems

Fuel nitrogen is presently responsible for about 50% of the  $\text{NO}_x$  emissions from stationary sources. As the use of high nitrogen fuels increases, this fraction will also increase. Methods aimed at inhibiting the

formation of  $\text{NO}_x$  from this source may inadvertently promote the production of  $\text{HCN}$ ,  $\text{NH}_3$ ,  $\text{N}_2\text{O}$ , or other nitrogenous species. Control techniques which have traditionally been used to reduce emissions of  $\text{NO}_x$  generated by the thermal fixation of atmospheric nitrogen are not generally found to be useful in inhibiting fuel-derived- $\text{NO}$  formation. Flue gas recirculation, water injection, and inert addition were found to increase the yield of  $\text{NO}$  or have no effect. Use of two-stage combustion, however, has been shown to effectively inhibit the conversion of fuel nitrogen to  $\text{NO}$ . However, since the primary stage of this system is fuel rich, the production of  $\text{HCN}$  and  $\text{NH}_3$  rather than  $\text{NO}$  is promoted. The fate of these species in the second stage is unclear and depends on several factors such as residence time, temperature history, and mixing intensity. Catalytic combustion has shown the ability to simultaneously minimize  $\text{CO}$ ,  $\text{UHC}$ 's, and thermal  $\text{NO}_x$  during fuel lean operation. The characteristics of this system during stoichiometric and fuel rich combustion have not been reported. The potential for emitting significant concentrations of  $\text{HCN}$  and  $\text{NH}_3$  when fuels containing bound nitrogen are burned has been exhibited by catalytic combustors. It would be advisable to monitor emissions of N-species such as  $\text{HCN}$ ,  $\text{NH}_3$  and  $\text{N}_2\text{O}$  from any device or strategy aimed at reducing the  $\text{NO}$  yield from fuel nitrogen since it is possible that the  $\text{NO}$  is reduced at the expense of increased emissions of these unwanted nitrogenous compounds.

#### 4.4 Noncombustion Sources

Because combustion generated N-species are a central topic of this report, this discussion of noncombustion sources is intended only for general informative purposes. Therefore, this section will be

cursory and will only cover the species of major importance: NO, NO<sub>2</sub>, N<sub>2</sub>O, HCN, NH<sub>3</sub> and nitrosamines.

Of the oxides of nitrogen, only N<sub>2</sub>O has large noncombustion sources. The principal source of NO is combustion and the major source of NO<sub>2</sub> is atmospheric conversion of NO. The oxides of nitrogen are also given off in the tail gas of nitric acid plants (U.S. Public Health Service, 1966) and from metal cleaning, electric arc welding, electroplating, engraving, and photogravure operations (Gleason et al., 1963). The major source of N<sub>2</sub>O is the bacterial denitrification of agricultural fertilizers. Estimates of production of N<sub>2</sub>O from the soil range from 24 Mtons/year (Hahn, 1974, 1975) to 55 Mtons/year (McElroy, 1975). In addition, the ocean may be a major source, at 134 Mtons/year (Hahn, 1974, 1975), or it may be a major sink, taking up 39 Mtons/year (McElroy, 1975). Because of these major gaps in the understanding of N<sub>2</sub>O, estimates of its atmospheric lifetime vary from 5 years (Hahn, 1974, 1975) to 170 years (Johnston and Selwyn, 1975). Craig et al. (1976) have found that N<sub>2</sub>O levels over the Pacific Ocean have increased 1.5% over the last decade.

Hydrogen cyanide is a protoplasmic poison and is lethal to all insects and animals (Henderson and Haggard, 1943). Therefore it makes an excellent fumigant and is used to kill domestic and agricultural parasites, resulting in the occasional accidental poisoning of farm-workers and fumigation service employees (Hamilton and Hardy, 1974). HCN is a byproduct of the manufacture of insecticides and synthetic chemicals, the extraction of gold and silver ore, and photographic, dying, plating, and steel heat-treating processes (Sterner, 1949).

The nitriles are also occasionally used as fumigants, especially for grains, and are found in many plants, particularly fruits and beans (Gleason et al., 1963). Although HCN is emitted in many industrial operations and was a major source of chemical intoxication 60 years ago (Gleason et al., 1963), it has not been of great concern to industrial toxicologists within the past decade or two.

Ammonia is given off by putrefying organic matter, and may reach concentrations as high as 1500 ppm in the immediate vicinity (Henderson and Haggard, 1943). It is used as a refrigerant and in the petroleum refining, steel, water purification, and fertilizer industries (Fairhall, 1969). Ammonia and amines are products of the anaerobic degradation of protein-rich materials, as in crop residues and manures. Dimethylamine is found in bodily wastes and is formed in the soil from trimethylamine. Amines are found in aquatic habitats and seem to result from the application of fertilizers in nearby agricultural centers. Secondary amines are given off to the air from feedlots and rendering plants. Secondary amines are used in the manufacture of the following products and may be emitted to the ambient air: antioxidants, vulcanization accelerators, pharmaceuticals, self-polishing waxes, synthetic detergents, pesticides, solvents, uranium oxide, wet-strength paper, corrosion inhibitors, animal glues, photographic products, leather, and the rocket fuel 1, 1-dimethylhydrazine. Nitrosamines may also be found in soil, plants, and water. In addition, nitrosamines may be given off in rubber factory processes, the combustion of 1, 1-dimethylhydrazine, fish meal processing, explosives manufacture, and the manufacture of soy bean oil. Although nitrosamines may be given off in an industrial process in which amines are added to power plant exhaust

to modify flyash resistivity, preliminary evidence indicates that they are not. Nitrosamines have also been measured in foods, including soy bean oil, fish meal, spinach, fried bacon, and smoked meat and fish. However, the fate of the amines is unclear (EPA, 1977).

One important source of exposure to nitrogenous species is a combustion source which does not readily correspond to the types of combustion sources covered in this thesis. The principal source of exposure to nitrogenous species for smokers is tobacco smoke, which has been shown to contain NO, NO<sub>2</sub>, HCN, NH<sub>3</sub>, secondary amines, and nitrosamines.

#### 4.5 Summary

The sources of nitrogenous emissions which are not associated with the fuel nitrogen problem may be generally categorized as previously unrecognized sources, new sources resulting from efforts to reduce air pollution, and noncombustion sources.

It was not recognized until relatively recently that nitrogenous species other than NO and N<sub>2</sub> could be emitted from spark ignition engines, compression ignition engines, gas turbines, power plants, or other combustion systems. The most important of these systems are probably automobiles and boilers. The species which may be emitted in the highest concentrations from spark-ignition engines are HCN and NH<sub>3</sub>. The most important previously unsuspected N-species emitted from power plants may be N<sub>2</sub>O. Other boilers may also emit cyanides and amines, especially HCN and NH<sub>3</sub>. The principal factors governing emission of these N-species seem to be: mixing intensity, residence time, and temperature history. It has been shown that odd N-species may be emitted even from very fuel lean

turbulent diffusion flames. The potential for emitting these compounds increases with increasing equivalence ratio. Fuel lean combustion appears to promote emission of  $\text{NO}_2$ .

Many air pollution control strategies which are directed at satisfying  $\text{NO}_x$  emissions regulations may inadvertently promote the emission of other objectionable N-species. Automotive exhaust purification catalysts have been shown to both produce and destroy HCN, depending on the operating conditions. The major pollutant N-species which are formed by these catalysts may be  $\text{NH}_3$  and  $\text{N}_2\text{O}$ . These two species may also be emitted in significant quantities from gas phase  $\text{NO}_x$  removal processes as applied to boilers. Fuel lean combustion systems, while decreasing total  $\text{NO}_x$  emissions, may promote the emission of  $\text{NO}_2$  in significant concentrations. It appears, that very fuel lean systems which are not using fuels containing bound nitrogen are the only combustion systems that are immune from emitting objectionable N-species other than NO.

As the switch to fuels containing bound nitrogen progresses,  $\text{NO}_x$  emissions from stationary sources will increase. Current air pollution control technology may inadvertently promote the production of HCN,  $\text{N}_2\text{O}$ ,  $\text{NH}_3$ , or other nitrogenous species. It would be advisable to monitor emissions of these species from any device which is directed toward reducing the NO yield from fuel nitrogen because it is possible that the NO is reduced at the expense of increased emissions of these unwanted nitrogenous compounds.

## CHAPTER 5

Potential Solutions to the NO Emissions Problem

The development of NO<sub>x</sub> control techniques has been caused by governmental regulations of NO<sub>x</sub> emissions. These controls either remove NO during exhaust aftertreatment or prevent NO formation through combustion system modification.

Exhaust aftertreatment (exhaust aftertreatment techniques were discussed in section 4.2) is advantageous because it controls emissions of both thermal and fuel-NO. However, exhaust aftertreatment devices may not be applicable to large combustion systems such as boilers because of size, cost, and lifetime considerations.

Therefore, combustion system modification for emissions control is of significant interest. Unfortunately, combustion system modifications which successfully control thermal-NO<sub>x</sub> are not universally effective in reducing emissions of fuel-derived NO, as shown in Table 5-1. Water injection and inert addition have been shown to increase the fraction of the fuel nitrogen which is converted to NO (the NO yield). For oil spray flames, increased mixing intensity increases the NO yield. Flue gas recirculation, which is similar to inert addition, may increase, decrease, or have no effect on the NO yield. Combustion staging decreases the NO yield and catalytic combustion probably decreases the amount of fuel-derived NO. However, in staged combustion the primary zone is fuel rich. This promotes the formation of HCN, NH<sub>3</sub>, and

TABLE 5-1

Effect of Thermal NO<sub>x</sub> Treatments on the NO Yield from Fuel-Nitrogen

Water Injection	Increases Fuel-NO	Wilkes & Johnson (1974) Fenimore (1976)
Increased Mixing Intensity	Increases Fuel-NO	Appleton & Heywood (1973)
Inert Addition	Increases Fuel-NO	Fenimore (1976)
Flue Gas Recirculation	May Increase, Decrease, or Have no effect	Brown, et al. (1973) Martin & Berkau (1971) Karo, et al. (1973), Turner, et al. (1972)
Two Stage Combustion	Decreases Fuel-NO	Martin & Dederick (1976) Gibbs, et al. (1976) Turner, et al. (1972)
Catalytic Combustion	Probably Decreases Fuel-NO	Yamagishi, et al. (1974)

nitrogenous species (N-species) other than NO. The fate of these N-species in the fuel lean second stage is unclear and depends on many factors, such as residence time, temperature history, and mixing intensity. As discussed later in this chapter, catalytic combustion exhibits the potential for producing high concentrations of HCN and NH<sub>3</sub>. Again, ultimate conversion to N<sub>2</sub> will depend on several design parameters. It would be advisable to monitor emissions of all N-species from any device or strategy aimed at reducing the NO yield from fuel nitrogen since it is possible that the NO is reduced at the expense of increased emissions of HCN, NH<sub>3</sub>, etc. Unfortunately, most of the studies which have investigated reduction of fuel-derived NO concentrated exclusively on the measurement of NO. There are three main reasons for this pattern:

- 1) NO is the only specifically regulated N-species.
- 2) NO is relatively easy to analyze quantitatively. Most of the other N-species are much more difficult to measure.
- 3) It has been assumed, up until recently, that the dominant nitrogenous species emitted from combustion systems were NO and N<sub>2</sub>. These are the only significant nitrogenous products which are predicted by equilibrium calculations for normal combustion conditions.

However, investigations cited in Chapters 3 and 4 have invalidated this last assumption. Nitrogenous species such as NO<sub>2</sub>, N<sub>2</sub>O, HCN and other cyanides, and NH<sub>3</sub> and other amines (including nitrosamines) have been shown to be emitted from various combustion systems even without the use of fuels containing nitrogen. The form of the nitrogenous products in the emissions from staged combustion systems and catalytic combustion systems is not clear, especially when fuels containing bound nitrogen are burned.

Staged combustion and catalytic combustion fall into another category of combustion modifications: methods of attaining overall fuel lean combustion. Turbulent diffusion flames are used almost universally in practical combustion systems, from compression-ignition engines to gas turbines to industrial boilers and furnaces. If there were a need for a combustion system which could maximize the emission of all major pollutants simultaneously, scientists and engineers would be hard-pressed to develop a better system than the turbulent diffusion flame for this purpose. Fortunately, a method which allows simultaneous minimization of the traditional pollutants has been the subject of much study. This method is generally termed "lean combustion." If combustion can be stabilized at very low fuel/air ratios, then CO and hydrocarbons will be emitted only in insignificant concentrations because of the excess oxygen condition. Furthermore, since lean combustion implies low flame temperatures and the rate of formation of NO through thermal fixation is exponentially dependent on temperature, the emission of thermal NO is also reduced to extremely low levels. Figure 5-1 shows the extent of NO reduction via lean combustion that has been experimentally demonstrated in comparison with data from commercial gas turbines. Another attractive characteristic of lean combustion is that it may improve the energy efficiency of some combustion devices. Unfortunately, little research has been reported which has explored the fate of fuel nitrogen in lean combustion systems.

Methods of stabilizing combustion of unusually fuel lean mixtures will be discussed in the remainder of this chapter, with particular emphasis on catalytic combustion. Catalytic combustion is of special interest because it may be applicable to systems for which the other

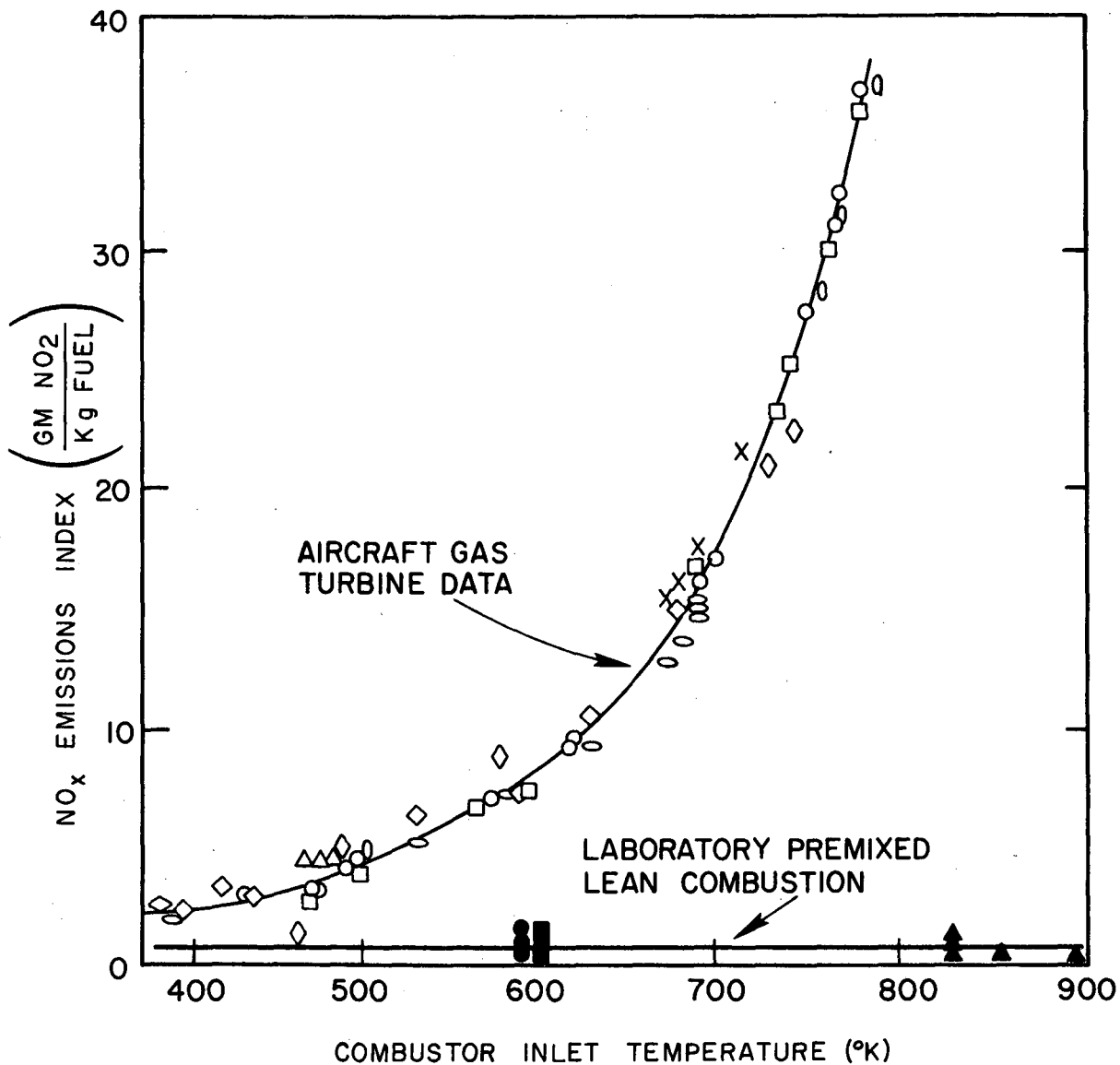

Figure 5-1. Potential for Oxides of Nitrogen Control Through Premixed Lean Combustion (Schefer and Sawyer, 1977)

methods are not practical. Furthermore, it may be possible to operate catalytic combustors in a mode where heterogeneous reactions dominate the  $\text{NO}_x$  formation mechanism. In this circumstance, it may be possible to minimize emission of NO even under fuel rich and stoichiometric conditions.

### 5.1 Lean Combustion

There are a number of methods for stabilizing combustion at equivalence ratios (the actual fuel/air ratio normalized by the stoichiometric fuel/air ratio) which are leaner than those which are attainable in a traditional turbulent diffusion flame. Table 5-2 lists some of these methods and the systems to which they are applicable. This table will be discussed in the following paragraphs.

Addition of hydrogen to other fuels will promote leaner combustion since hydrogen has a much higher flame speed than other fuels. Hydrogen supplementation has been investigated as one method of attaining lean combustion in spark ignition engines. Rupe (1973) and Stebar and Park (1974) have demonstrated the effectiveness of this technique in suppressing emissions of NO from single cylinder engines. The feasibility of hydrogen enrichment in piston engines was shown by Houseman and Cerini (1974), Hoehn and Dowdy (1974), and Houseman and Hoehn (1974).

More recently, Cichanowicz and Sawyer (1976) inhibited NO and CO formation in a rotary engine at equivalence ratios as lean as 0.49. They found that the indicated thermal efficiency could be maintained relatively constant with decreasing equivalence ratio by increasing the  $\text{H}_2/\text{C}_8\text{H}_{18}$  ratio. The brake thermal efficiency was shown to increase marginally with increasing  $\text{H}_2/\text{C}_8\text{H}_{18}$  fraction at constant power. Un-

TABLE 5-2

Lean Combustion

<u>Method</u>	<u>Potential Applications</u>
Hydrogen Supplementation	Spark Ignition Engines, Gas Turbines
Heat Recirculation	Gas Turbines, Boilers & Furnaces
Premix, Prevaporize, Preheat	Gas Turbines, Boilers & Furnaces
Catalytic Combustion	Gas Turbines, Boilers & Furnaces, Space Heaters
Staged Combustion	Gas Turbines, Boilers & Furnaces, Spark Ignition Engines

00004901114  
-129-

fortunately, the UHC emissions increased slightly under lean operation. The differences in rotary and reciprocating engines notwithstanding, Cichanowicz and Sawyer demonstrated that the amount of hydrogen required to attain a given lean operating limit was not significantly different in these two types of spark ignition engines.

Hydrogen supplementation has become even more attractive because of the introduction of onboard hydrogen generators by The Jet Propulsion Laboratory (1974), Siemens, International Materials, and Philips Petroleum. The use of gasoline reformers overcomes the safety, weight, and/or distribution problems associated with the need to carry compressed hydrogen or metal hydrides in the vehicle.

The use of pure hydrogen as a fuel for aircraft engines was suggested more than twenty years ago by Silverstein and Hall (1955). Austin and Sawyer (1973) have noted that the use of hydrogen as a fuel for jet aircraft would not only allow lean combustion and therefore minimize  $\text{NO}_x$  emissions, but would virtually eliminate CO, hydrocarbons, and particulates because of the absence of carbon in the fuel. Hydrogen supplementation to attain lean premixed combustion in a gas turbine is another possible approach.

Heat recirculation is another means of stabilizing lean combustion. In this method, most of the waste heat available in the products of combustion is transferred to the reactants via conduction through the thin separating surfaces of a counterflow heat exchanger. This heat transfer process raises the inlet temperature and provides some of the energy necessary to activate the reaction. Massive heat recirculation not only is capable of stabilizing combustion near what is

normally thought of as the lean flammability limit, but has been shown to be capable of lowering the actual flammability limit to a value bordering on an equivalence ratio of zero (Lloyd and Weinberg, 1975). Therefore, the utilization of fuels of very low heat content is made possible in this combustion system. Furthermore, Lloyd and Weinberg explain how premixed lean combustion with heat recirculation can result in an increase in energy efficiency substantial enough to provide more than twice the energy currently produced by all nuclear and other noncombustion sources.

Early experiments used spiral-type burners (Lloyd and Weinberg, 1974 and 1975; Hardesty and Weinberg, 1974). Recent experiments by Angeli (1977) have demonstrated the feasibility of planar heat exchangers. Ganji, et al. (1976a, b) have applied thermodynamic, chemical kinetic, and heat transfer analyses to the design of an aircraft gas turbine which utilizes heat recirculation. Their calculations indicate that combustion zone equivalence ratios as low as 0.2 can be stabilized. Furthermore, the heat release is maintained with reaction completion occurring substantially before the NO forming reactions can proceed. However, CO can be rapidly oxidized in this region. The heat recirculation combustor size would have to be slightly larger than conventional combustors. They conclude that heat recirculation is a feasible method for the stabilization of lean combustion in gas turbines. This technique has application to space heating, gas turbines, recombustion of exhaust gases, and thermionic power generation.

Premixing, prevaporizing and preheating the reactants is a technique which is especially applicable to gas turbines. Premixing and prevaporization are necessary to ensure a uniform fuel-air distribution. Mixture uniformity eliminates the locally fuel-rich and stoichiometric regions characteristic of turbulent diffusion flames. Therefore, the formation of particulates, unburned hydrocarbons, CO and NO characteristic of these conditions can be significantly reduced. Preheating is necessary to provide the heat of vaporization for liquid fuels and also helps stabilize the lean combustion process (Blazowski and Sawyer, 1975). This latter function is similar to that of Weinberg's heat recirculation, but the amount of preheat is not as extensive. In this case, the preheat is provided by radiative heat transfer from the flame and also as a natural byproduct of the compression process necessary to gas turbine operation. In addition to the substantially decreased emissions of NO, premixed/prevaporized gas turbine combustors can also exhibit improved combustion efficiency at idle (Azelburn, et al., 1973; Mosier and Roberts, 1974; Troth, et al. 1974). Mellor (1976), in his review of gas turbine pollution, notes that premixed/prevaporized engines may have flashback difficulties but indicates that this problem may be overcome through proper design. As mentioned previously, the premixing, preheating, and prevaporizing technique is especially applicable to gas turbines, not only for jet aircraft but also for automotive, truck, and stationary applications as well.

Staged combustion is a method of combining fuel rich combustion with fuel lean combustion to stabilize an overall fuel lean process. The fuel rich stage overcomes the ignitability problems often asso-

ciated with lean combustion.  $\text{NO}_x$  production is inhibited in this stage because of the lack of available oxygen. The exhaust from the first stage is delivered to the second stage, where it is mixed with air and the combustion process is completed. The lean second stage is stabilized by the heat which it receives with the partial oxidation products from the first stage. The low temperatures associated with combustion in the fuel lean second stage inhibit thermal  $\text{NO}_x$  formation. Spark ignition engines, gas turbines, and commercial and industrial boilers are potential applications of staged combustion and will be discussed in the following paragraphs. Investigations concerning the conversion of fuel nitrogen to  $\text{NO}$  during staged combustion will also be discussed.

One common example of the staged combustion concept is the divided chamber stratified charge engine. Honda first introduced its CVCC in 1975, and because of its success other auto manufacturers are investigating its application. However, Noguchi, et al. (1976) have found that significant concentrations of  $\text{NO}_2$  can be emitted from this overall fuel lean system. The divided chamber stratified charge engine is compared with other methods of achieving lean combustion in spark ignition engines in Table 5-3. The divided chamber stratified charge engine exhibits very low  $\text{NO}$ ,  $\text{CO}$ , and UHC emissions with no fuel economy penalty and good durability. Exhaust gas recirculation plus spark retard cannot achieve  $\text{NO}_x$  emissions much less than 2.0 gm/mi and the fuel economy is very poor. The open chamber stratified charge engine has been a subject of investigation for more than three decades. Current versions include the Texaco TCCS, the Ford PROCO, and the Ford "fast-burn" engines. With the aid of exhaust aftertreatment devices

TABLE 5-3

Comparison of Methods for Attaining Lean Combustion In Spark Ignition Engines\*

<u>Concept</u>	$\phi$	<u>Emissions (gm/mi)</u>			<u>Fuel Economy</u>	<u>Durability</u>
		<u>NO</u>	<u>CO</u>	<u>UHC</u>		
EGR & Spark Retard	—	3.1**	15.0	1.5	-10%	good
Open Chamber Stratified charge	—	.4	3.4	.41	0	very poor
Divided Chamber Stratified charge	—	.6-.10***	2.4	.4	0	good
Advanced Carburetion	.79-.88	1.5	9.0	.9	+10-15%	—
H <sub>2</sub> Addition	.5 -.6	.4	3.4	>3	+10.15%	—

---

\* From the data compiled for ERDA by the Aerospace Corporation (1976).

\*\* NO<sub>x</sub> emissions as low as 2.0 gm/mi can be achieved with a severe fuel economy penalty.

\*\*\* 2000 pound weight class. For the 5000 pound class, NO<sub>x</sub> emissions would increase to 1.4-1.7 gm/mi while the CO and UHC emissions would not change significantly.

they can meet the 1978 Federal passenger car emission standards. Without exhaust aftertreatment, they cannot meet the standards but do show a 30% fuel economy gain. Open chamber stratified charge engines have exhibited very poor durability. Advanced carburetion can reduce  $\text{NO}_x$  to 1.5 gm/mi with an increase in fuel economy. This concept is currently being pre-production tested by Dresser Industries. Hydrogen addition can reduce  $\text{NO}_x$  levels even further with a similar fuel savings. However, UHC emissions are high and would require exhaust aftertreatment. The durability of advanced carburetor and hydrogen addition systems has not been investigated.

In a unique configuration of a staged engine, Houseman and Cerini (1976) calculated that the optimum design for a two-stage spark ignition V8 would have 3 rich cylinders and 5 lean cylinders if all cylinders operated on the 4 stroke cycle. However, 2 stroke operation of the first stage would allow a 2/6 rich/lean distribution resulting in more calculated power. They also found that the first stage should operate at equivalence ratios between 1.5 and 2.0 to ensure sufficient heat release to the second stage yet inhibit soot formation. The results of steady state operation on a CFR engine indicate that the two-stage system may be able to meet the 1978 Federal passenger car standards of .4 gm/mi for  $\text{NO}_x$  and .41 gm/mi for HC's. However, CO emissions were shown to be extremely sensitive to overall equivalence ratio and it was considered doubtful that the 3.4 gm/mi standard could be met. Furthermore, the power output was very low although proper engine design may be able to compensate for this weakness.

Verkamp, et al. (1974) have demonstrated that staged combustion can simultaneously lower NO and CO emissions from gas turbines. Staged gas turbine combustors have two fuel injectors and two combustion zones. Only one fuel nozzle is used at idle; both are used at high power. Because there are two combustion zones, the overall equivalence ratio in each can be maintained leaner than in a conventional combustor. Premixing, prevaporization, and preheating may be used in conjunction with fuel staging to further improve emissions and combustion characteristics. Lefebvre and Fletcher (1973) have demonstrated that staged combustion can decrease NO by a factor of 2 below a similar conventional combustor operating under the same conditions. However, Mosier, et al. (1973) have shown that HC and CO may increase with this method. Optimization of combustor and fuel injector designs should overcome this problem and gas turbines utilizing the staged fuel addition concept are expected to be included in designs for the next generation of aircraft engines (Mellor, 1976).

Barnhart and Diehl (1960) have demonstrated the successful application of two-stage combustion to steam power plants. This was accomplished at minimum cost simply by operating some burners at less than stoichiometric air and shutting off the fuel supply to other burners. With both oil and gas firing, a 30% reduction in NO could be attained at 95% stoichiometric air through the operating burners. At 90% stoichiometric, the NO reduction approached 50%. The authors suggest reduction of air by another 5 or 10%.

Two-stage combustion has also been investigated for potential application to industrial boilers. Siegmund and Turner (1974)

and Turner, et al. (1972) found that two-stage combustion inhibited thermal and fuel  $\text{NO}_x$  formation more effectively than flue gas recycle or minimizing excess air. However, they indicate that application of staged combustion to industrial boilers may be much more difficult than for utility boilers, perhaps prohibitively so.

Martin and Dederick (1977) investigated two-stage combustion of a simulated coal derived gas containing  $\text{NH}_3$ . In this laboratory combustion system, they found that  $\text{NO}_x$  emissions could be lowered by about a factor of 8 with a primary zone equivalence ratio of 1.7. However, a small fraction of  $\text{NH}_3$  could pass through the system unreacted under this condition. Also, there was no attempt to measure emissions of other N-species, such as HCN and  $\text{N}_2\text{O}$ .

Yamagishi et al. (1975) studied staged combustion in a system which allowed continuous variation of the primary zone fuel/air mixture from completely premixed to a conventional turbulent diffusion flame. They found that formation of HCN,  $\text{NH}_3$ , and even NO under fuel rich conditions was dependent on how premixed the primary combustion zone was. As seen in Figure 4-3, these N-species were emitted from the primary combustion zone at maximum concentrations in the turbulent diffusion flame mode with decreasing levels as the  $\text{CH}_4$  and air became more and more premixed. Total  $\text{NO}_x$  in the exhaust followed a similar pattern. However, a chemiluminescent analyzer was used for total  $\text{NO}_x$  analysis, a method which has since come under question (see section 6.2.d). Figure 5-2 shows the effect of primary zone equivalence ratio on emissions of NO, HCN, and  $\text{NH}_3$ . Levels of these species are shown to be decreasing with increasing equivalence ratio. However, these conditions may favor the formation of larger

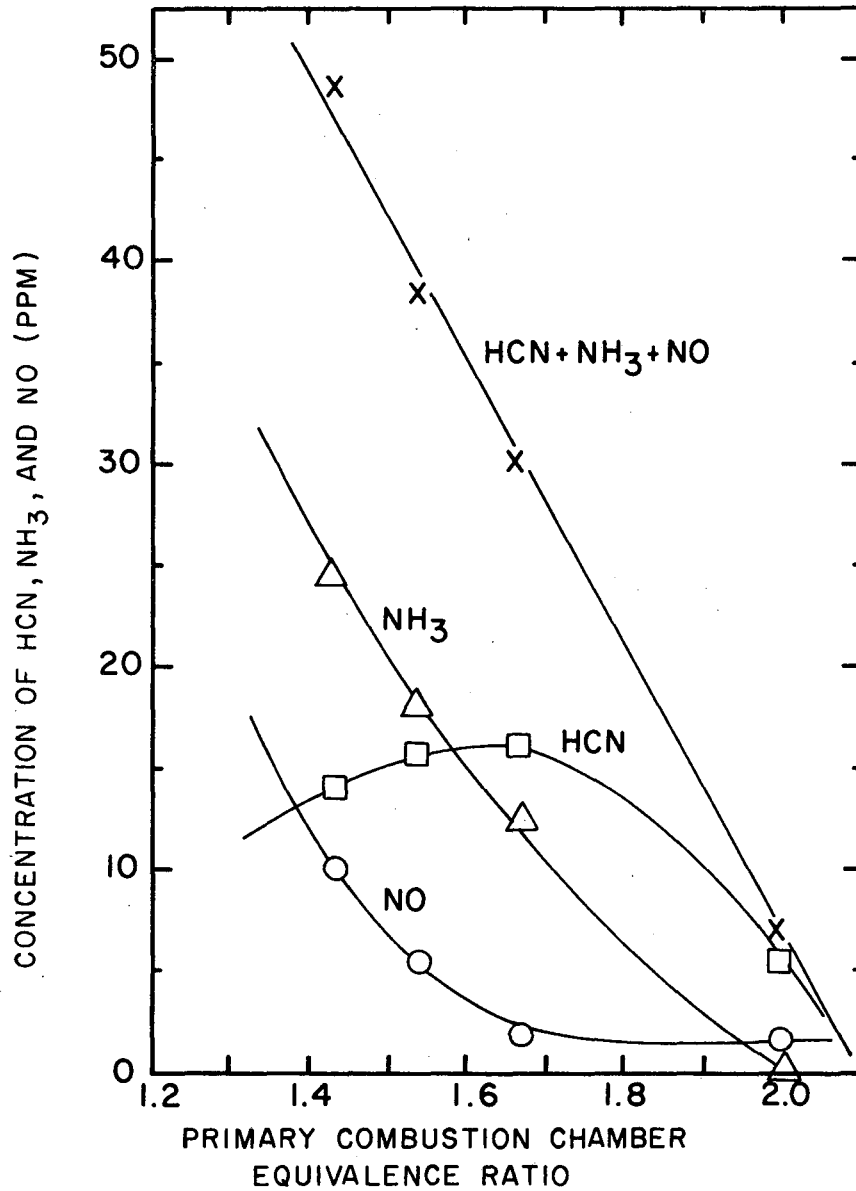

Figure 5-2. Relationship Between Equivalence Ratio and Formation of HCN, NH<sub>3</sub>, and NO in the Primary Combustion Chamber of a Two Stage Combustion System (Yamagishi et al., 1974)

nitrogenous molecules, such as methyl cyanide and dimethylamine, which were not measured. They also found that when NO was added as a model fuel nitrogen compound, it was converted almost completely to HCN in the exhaust. This is a very important investigation because it demonstrates that nitrogenous species other than NO and N<sub>2</sub> may be emitted from the fuel rich primary zone in staged combustion, especially in the presence of fuel-nitrogen. The fate of these species in the secondary zone is uncertain.

Bartok et al. (1971) point out that the problems of developing combustion modification techniques for the control of NO in coal-fired boilers are very difficult. However, Gibbs et al. (1977) have investigated a system which may overcome these inherent problems. They have shown that air staging can significantly reduce NO emissions from fluidized-bed coal combustors. However, no measurements were attempted which would assure that the fuel-nitrogen was converted to N<sub>2</sub> rather than some less desirable product.

Catalytic combustion is the last means of attaining lean combustion which will be dealt with in this chapter. However, because this topic is of central importance in this report, a completely separate section will be devoted to it.

## 5.2 Catalytic Combustion

Catalytic combustion enjoys several general advantages in comparison with the other methods of attaining lean combustion. These advantages are listed in Table 5-4. Catalytically stabilized combustors are capable of utilizing a wide range of fuels, including fuels of very low energy content, residual fuel oil, and perhaps even pulverized coal. They can be operated either in the premixed or in the diffusive mode

TABLE 5-4

Advantages of Catalytically Stabilized Combustion

Multi-Fuel Capability

Low BTU Fuels

$\text{CH}_2$ ,  $\text{CH}_4$ ,  $\text{C}_3\text{H}_8$

JP4, Jet A

Residual Fuel Oil

Possibly Pulverized Coal

Capable of Operating in the Premixed and Diffusive Modes

Operation Over an Extended Range of Equivalence Ratios, Possibly Including Stoichiometric and Fuel Rich Combustion

Wide Range of Potential Applications

Space Heating

Industrial Process Heating

Range Top Burners

Gas Turbines

Boilers and Furnaces

Ignitors

Flame Holders

(Dongworth and Melvin, 1977). Applications include space heating, industrial process heating, range top burners, stationary gas turbines, automotive gas turbines, aircraft gas turbines (if high altitude relight problems can be overcome), ignitors, flame holders, and boilers for industrial, commercial, and domestic use. This last application implies another important characteristic.

Because of the desirability of operating boilers at mixture ratios near stoichiometric to minimize stack losses, the application of catalytic combustors to boilers requires special consideration. It is possible that catalytic combustors could be operated in a mode where heterogeneous reactions are dominant and thereby minimize  $\text{NO}_x$  emissions even near stoichiometric. However, because the current generation of catalytic combustors cannot withstand the temperatures generated by stoichiometric combustion, this possibility has not been tested experimentally. This leaves two other possible means of applying the catalytic combustion concept to boilers: 1) fuel lean combustion with a stack loss or 2) staged catalytic combustion with a rich first stage and a lean second stage to yield an overall stoichiometric system. Energy removal would probably be applied between the two stages. These last two methods require investigation of fuel rich and slightly lean catalytic combustion.

Because of a distinct division in the types of applications of catalytic combustion, previous investigations can be divided into two categories. The first classification involves catalytic combustion under unusually fuel lean conditions. Catalytic combustion of slightly lean, stoichiometric, and rich mixtures is also of significant interest. Research into very lean operation will be discussed first, followed by

a discussion of catalysts operated under near-stoichiometric conditions.

Table 5-5 summarizes the investigations of gas turbine catalytic combustion which have been done to date. The  $\text{NO}_2$  emissions index ( $\text{EI}_{\text{NO}}$ ) for a conventional gas turbine at  $650^\circ\text{K}$  inlet temperature, 9 atmospheres, and an exit temperature of  $1366^\circ\text{K}$  would be more than 10 gm  $\text{NO}_2/\text{kg}$  fuel (Blazowski and Walsh, 1975). The  $\text{EI}_{\text{NO}}$  for catalytic combustion is seen to be less than 0.1 for similar conditions. That is, NO is emitted in concentrations of less than 6 ppm. Fuels investigated included both gas phase ( $\text{CH}_2$ ,  $\text{CH}_4$ , and  $\text{C}_3\text{H}_8$ ) and liquids (JP4 and Jet A). Use of #2 distillate fuel and a low Btu fuel demonstrated the very wide range of applicable fuels (De Corso et al., 1976; Pfefferle et al., 1975). The success of these fuels is important because of the possible need to use alternate fuels by the late 1980's.

An important parameter of interest in these investigations was the combustion efficiency,  $\eta_b$ , which is a measure of completion of combustion. Pfefferle et al. (1975) report that  $\eta_b$  decreases for an equivalence ratio ( $\phi$ ) less than 0.39 for  $\text{C}_3\text{H}_8$  at  $3 \times 10^5$  Pa pressure, an inlet temperature of  $340^\circ\text{K}$ , and an inlet velocity of 13 m/sec. Anderson (1977) shows  $\eta_b$  decreasing for  $\phi$  between 0.26 and 0.30 depending on catalyst material and reference velocity. He also used  $\text{C}_3\text{H}_8$  at  $3 \times 10^5$  Pa but raised the inlet temperature to  $800^\circ\text{K}$ . Blazowski and Walsh (1975) report  $\eta_b$  falling off for  $\phi < 0.037$  using JP4 at  $7 \times 10^5$  Pa, with a reference velocity of 13.7 m/sec and  $650^\circ\text{K}$  inlet mixture. They also demonstrated that  $\eta_b$  decreases with increasing inlet velocity above about 14 m/sec. The efficiency decreased more rapidly for leaner mixtures. Pfefferle et al. (1975) report the same trend with  $\eta_b$  falling below  $\sim 1.0$  at an inlet (or reference) velocity of 12 m/sec and

TABLE 5-5  
Investigations of Very Lean Catalytic Combustion

	Fuel	$\phi$	P (atm)	T <sub>in</sub> (°K)	v <sub>in</sub> (m/sec)	NO <sub>x</sub> (ppm)	EINO <sub>x</sub> (gm/kg fuel)
Blazowski & Walsh (1975)	JP4	.02-.05	4-11	650			<.1
Caton (1976)	CH <sub>2</sub>	.05-.15	1	300-850			
Anderson (1977)	C <sub>3</sub> H <sub>8</sub>	.14-.32	3	800	10-25		<.1
Wampler et al. (1976)	C <sub>3</sub> H <sub>8</sub>		1	530-730			<.1
Anderson et al. (1977)	Jet A		5	800	15	<.5	
	C <sub>3</sub> H <sub>8</sub>		3	800	10-25	<.5	
Pfefferle et al. (1975)	C <sub>3</sub> H <sub>8</sub> , CH <sub>4</sub> , JP4, low Btu #2 Diesel		1-4	500-900	8-26	< 2	
De Corso et al. (1976)	low Btu, #2 distillate propylene		3		22-38	< 6	

00004901121

an inlet temperature of 320° C. The combustion efficiency can be maintained at approximately 1.0 by raising the inlet temperature. For example, at  $T_{IN} = 360^{\circ} \text{C}$ ,  $\eta_b$  does not start to decrease until the reference velocity exceeds 19 m/sec. DeCorso et al. (1976) and Blazowski and Walsh have also noted that combustion efficiency increases with increasing inlet temperature. Lastly, Blazowski and Walsh show that the efficiency is approximately independent of pressure between 4 and  $11 \times 10^5$  Pa. The evidence shows that combustion efficiency increases with increasing equivalence ratio, increasing inlet temperature, and decreasing inlet velocity and is independent of pressure.

Because application of catalytic combustion to aircraft gas turbines poses special problems, the development of a hybrid catalytic combustor has been suggested by Siminski and Shaw (1977). In this system, a fuel rich precombustion zone and secondary air addition precede the catalytic combustor. The principal advantages of this system are ease of ignition and avoidance of the problems associated with premixing and prevaporization. The average EI for  $\text{NO}_x$  is up an order of magnitude compared to conventional catalytic combustors, to 1.8 g/kg fuel. However, this value is still below the 1981 new aircraft emission standards. Unfortunately, UHC emissions are slightly higher than the 1981 standards will permit.

Yamagishi et al. (1974) have also investigated a combination of combustion staging and catalytic combustion. However, in this design the catalyst is situated between the fuel rich primary stage and the section where secondary combustion occurs. The catalyst was one of several methods they investigated for removing the HCN and  $\text{NH}_3$  which are formed in the fuel rich primary stage. The best of the several

catalysts which they tried reduced  $\text{NO}_x$  in the exhaust by 38%. It also lowered the concentration of HCN at the exit of the primary stage (which also is the downstream side of the catalyst) by 59%,  $\text{NH}_3$  by 38%, and NO by 59%. Nevertheless, the concentrations of these species range from 4 - 14 ppm, indicating that a significant fraction of  $\text{NH}_3$ , NO, and HCN entering a catalytic combustor under fuel rich conditions may escape unreacted. This investigation by Yamagishi and coworkers appears to be the only published report of emissions of N-species from fuel rich catalytic combustion. Even in this experiment, the reactants were partially combusted before entering the catalyst. Therefore, it can be stated that there have been no published investigations concerning fuel rich or near stoichiometric catalytic combustion.

### 5.3 Summary of Chapter 5

Emissions of NO due to combustion of fuels containing organically bound nitrogen is a significant air pollution problem and will become even more important in the near future. All but two of the traditional methods for controlling NO from thermal fixation either increase fuel NO or have no effect. These two are staged combustion and catalytic combustion. They also fall into the category of air pollution control strategies which share lean combustion as a common characteristic. It has been shown that staged combustion can decrease emissions of thermal NO and fuel NO but it has also been found that significant levels of HCN and  $\text{NH}_3$  (and presumably other N-species) are formed in

the fuel rich primary stage. The extent of conversion of these species to NO and N<sub>2</sub> at the exit from the combustion device is not clear. Catalytic combustion does not appear to emit significant quantities of N-species under lean operating conditions in the absence of fuel nitrogen. However, very little research has been aimed at investigating nitrogenous emissions in the presence of fuel-N, especially under near-stoichiometric and fuel rich conditions. This last case is of utmost interest because commercial and industrial boilers are the systems which are most likely to utilize the fuels which contain bound nitrogen and system thermal efficiency considerations dictate that they operate near stoichiometric.

## CHAPTER 6

Experimental Objectives and Apparatus

The previous chapters have provided background information on the three major subjects of this thesis: emissions of nitrogenous species other than NO and  $N_2$ , fuel nitrogen, and catalytic combustion. Now that the necessary background information has been assembled, a detailed statement of the experimental objectives will be given and the experimental apparatus will be discussed.

6.1 Detailed Statement of Experimental Objectives

Previous investigations of catalytic combustion have been aimed primarily at developing catalytic combustors for very fuel lean operation. There is very little published information about fuel rich and near stoichiometric catalytic combustion. Furthermore, there have been no major studies of the fate of fuel nitrogen in catalytic combustion systems. The information that is available indicates that significant concentrations of HCN and  $NH_3$  may be emitted. This work examines the effect of catalytic combustion on fuel nitrogen conversion. Because emission of nitrogenous species other than NO is considered to be important, the identification of other N-species in the products is sought. Comparison with emissions from a flat flame burner operating under the same conditions is made to allow an estimation of the extent to which heterogeneous reactions dominate the fuel nitrogen conversion mechanism.

To allow quantification of the  $N_2$  yield (the fraction of the fuel

nitrogen which is converted to  $N_2$ ), an oxygen-argon mixture is used as the oxidizer. Figure 6-1 shows the effect of the oxygen to argon ratio on the adiabatic flame temperature as a function of  $C_3H_8/O_2$  equivalence ratio. By varying the  $O_2/Ar$  ratio while maintaining a constant  $C_3H_8/O_2$  ratio, it is possible to change the flame temperature at constant equivalence ratio. This process is illustrated in Figure 6-1 by line A-B. By varying both ratios simultaneously, it is possible to change the equivalence ratio while maintaining the flame temperature constant, as illustrated by line B-C. Use of the  $O_2$ -Ar mixture as an oxidizer, then, has two advantages: 1) it allows a decoupling of two normally interdependent combustion parameters, equivalence ratio and adiabatic flame temperature; 2) it allows quantification of small concentrations of  $N_2$ , and therefore the  $N_2$  yield.

Even though the kinetics of propane oxidation are not well known,  $C_3H_8$  is chosen as a fuel because its combustion characteristics closely resemble those of commercial fuels. Methane, for which the kinetics are fairly well understood, has been shown to exhibit some anomalous characteristics. Furthermore, propane is the fuel most often used in previous catalytic combustion experiments. These accumulated data may be drawn upon to establish experimental conditions in the present investigation.

Previous investigations of catalytic combustion have found that the combustion efficiency increases with increasing equivalence ratio (for fuel lean combustion), increasing inlet temperature, and decreasing inlet velocity. The combustion efficiency for near stoichiometric and fuel rich catalytic combustion has not been reported. In this investigation, the inlet temperature is constrained to be 298 K. The

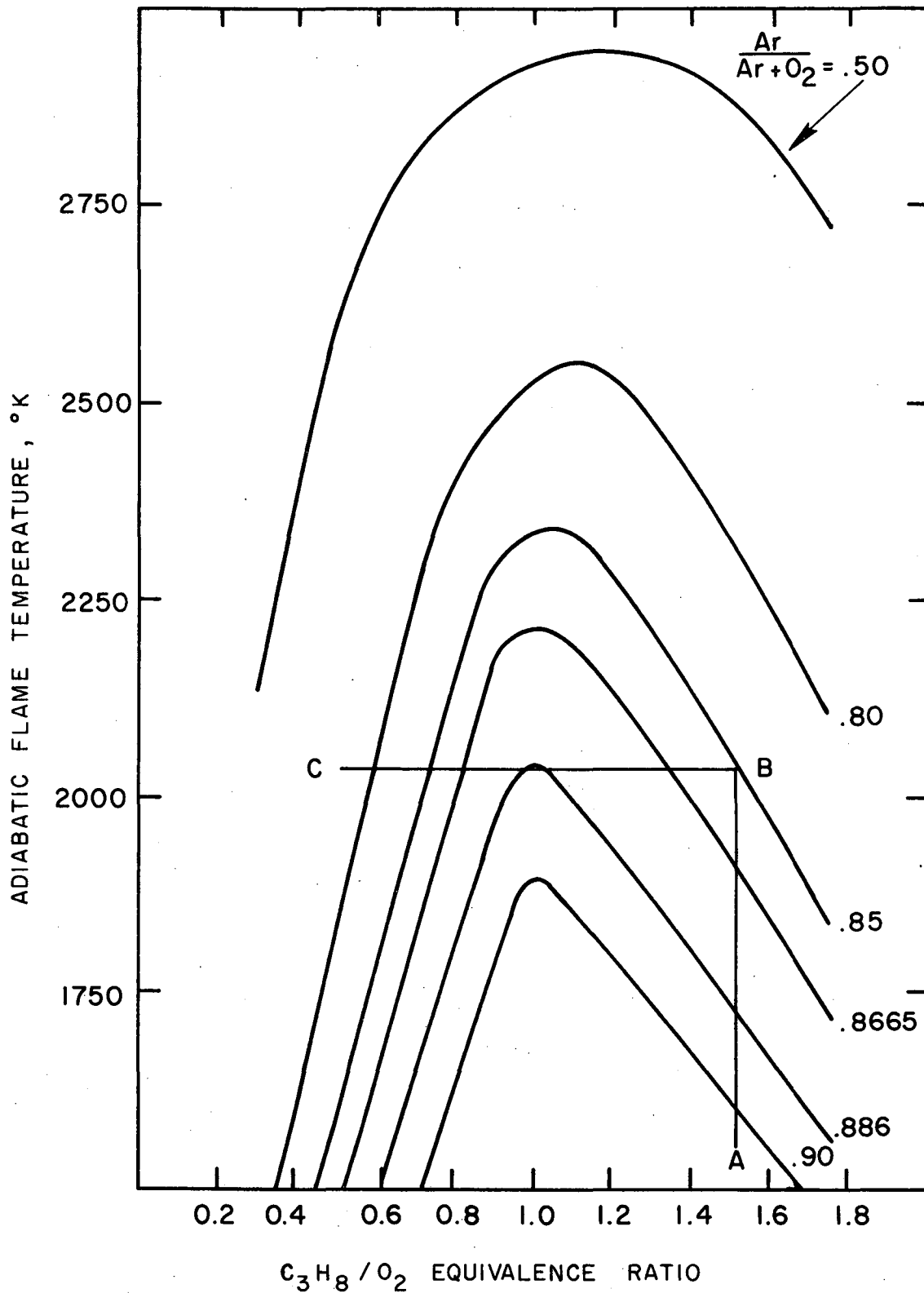

Figure 6-1. Effect of the Argon to Oxygen Ratio on the Relationship Between Equivalence Ratio and Adiabatic Flame Temperature

inlet velocity is about 0.05 m/sec, a value chosen to match the optimum flat flame burner operating conditions. This low inlet temperature might be expected to cause inefficient catalytic combustion, but the very low inlet velocity should increase the combustion efficiency. Because of these questions concerning the combustion efficiency, it is measured experimentally:

The catalytic combustor inlet velocity was chosen at the value for which a flat flame could be stabilized on the flat flame burner. Recall that the two combustion systems were intended to be operated under the same conditions so that comparisons could be drawn. A ceramic, uncooled flat flame burner, similar to the one described by Sawyer et al (1976), was used. Because the burner is uncooled, the range of equivalence ratios over which a flat flame could be stabilized was extremely limited. This combustion system was, therefore, operated only at one equivalence ratio, approximately 1.25. Fuel nitrogen is converted to NO at yields approaching 100% for most lean and stoichiometric flames and at yields approaching 0% for very fuel rich flames. The  $\phi = 1.25$  case was considered to be an interesting intermediate which would allow a comparison between catalytic combustion and homogeneous reaction (i.e. flat flames).

Several trends have been noted in the parametric studies of fuel nitrogen conversion to NO discussed in Chapter 3. Three of the most important of these are investigated to determine the effect of catalytic combustion on NO yields as a function of equivalence ratio, flame temperature and fuel nitrogen concentration. For comparative purposes, the effect of flame temperature and fuel nitrogen concentration on NO yields were studied using the flat flame burner. All experiments were conducted at a pressure of  $10^5$  Pa.

The term fuel nitrogen "concentration" is somewhat confusing because it may be construed to mean the concentration of nitrogen in the fuel or the concentration of fuel nitrogen compound in the reactants. By convention, it generally means the concentration of nitrogen in the fuel. However, fuel nitrogen "fraction" may be a less ambiguous term and is used in the remainder of this thesis in any context where "fuel-N concentration" is not clear. The fuel nitrogen concentration is calculated as the mass flowrate of nitrogen in the reactants divided by the sum of the mass flow rates of the propane and the additive ( $\text{NH}_3$  or  $\text{NO}$ ). In this manner, the additive is defined as a fuel. This results in minor differences in operating conditions when using  $\text{NH}_3$  and  $\text{NO}$  because  $\text{NO}$  is actually an oxidant and  $\text{NH}_3$  is a fuel.

## 6.2 Experimental Apparatus

Figure 6-2 illustrates the experimental apparatus. For convenience the equipment can be divided into four categories: flow metering and measurement, combustors and housing, probe and sample transfer systems, and analytical equipment. Each of these categories will be discussed in the following subsections.

### a. Flow Metering and Measurement

There were four reactants whose flows had to be accurately measured:  $\text{C}_3\text{H}_8$ ,  $\text{O}_2$ , Ar, and either  $\text{NH}_3$  or  $\text{NO}$ . Preliminary experiments indicated that there could be substantial difficulties associated with metering and measuring low flowrates of pure  $\text{NH}_3$  and  $\text{NO}$ . For this reason, mixture gases were used which contained approximately 1%  $\text{NH}_3$  or  $\text{NO}$  in an Ar balance. Four Hastings linear mass flowmeters were used to measure the flowrates of  $\text{C}_3\text{H}_8$ ,  $\text{O}_2$ , Ar and the mixture gas ( $\text{NH}_3$  or  $\text{NO}$  in an Ar balance). By maintaining the flowrates of  $\text{C}_3\text{H}_8$ ,  $\text{O}_2$ , and  $\text{NH}_3/\text{Ar}$  constant and varying the

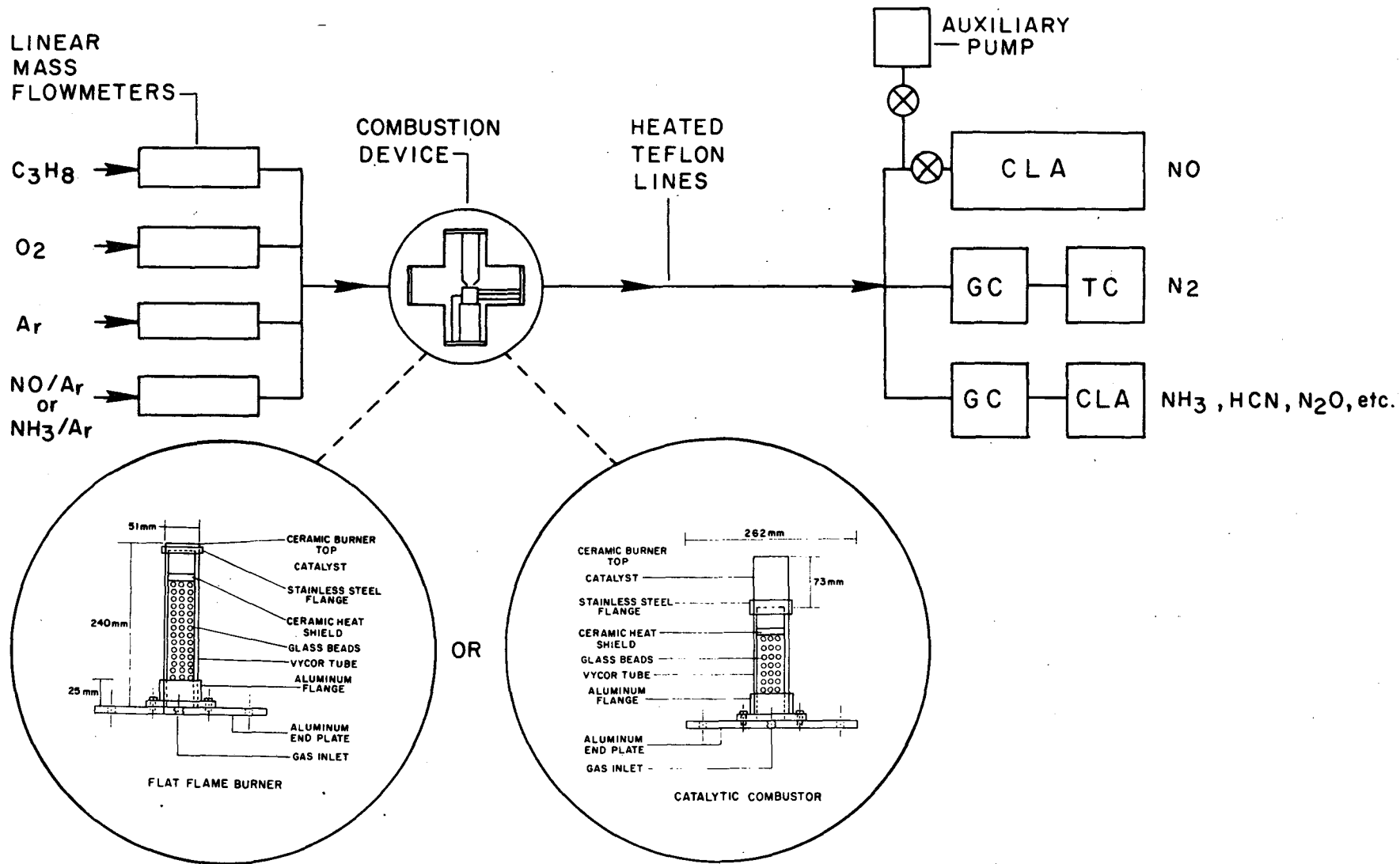

Figure 6-2. Experimental Apparatus

Ar flowrate, the adiabatic flame temperature,  $T_{AD}$ , can be varied at constant equivalence ratio,  $\phi$ , and fuel nitrogen concentration, [FN]. By varying the  $NH_3$  (or NO)/Ar and Ar flowrates only, the [FN] can be varied at constant  $\phi$  and  $T_{AD}$ . All four flowrates must be varied simultaneously to vary  $\phi$  at constant  $T_{AD}$  and [FN].

b. Combustion Devices, Housing, and Traversing Mechanism.

A six inch glass cross is used to house the flat flame burner and catalytic combustor. Each of these combustion devices is mounted on an aluminum end plate which can bolt to the bottom flange of the glass cross. A similar end plate, which holds the probe and traversing mechanism, is bolted to the top flange. Plexiglass end plates are bolted to the two side ports and can be removed to ignite the flame with a propane torch. The cross rests in a wooden cradle, which is visible in Fig. 6-2.

Figure 6-3 is a representation of the flat flame burner, which is similar to the one used by Sawyer et al (1976). It is an uncooled burner with a 4.6 cm diameter surface which is constructed with the Corning Ceramic, Cercor T20-38. The ceramic burner sits atop a Vycor tube which allows visual inspection of the glass beads and ceramic heat shield encased in it. The reactant gas mixture is introduced through the bottom of the end plate. The glass beads are intended to flatten the velocity profile.

Figure 6-3 also shows the catalytic combustor which is very similar to the flat flame burner. It consists of an aluminum end plate, a Vycor housing, glass beads, a ceramic heat shield, and the catalyst. The catalyst consists of a monolithic Cordierite ceramic substrate with a  $\gamma$ -alumina washcoat and a 0.187% platinum loading. This catalyst was made

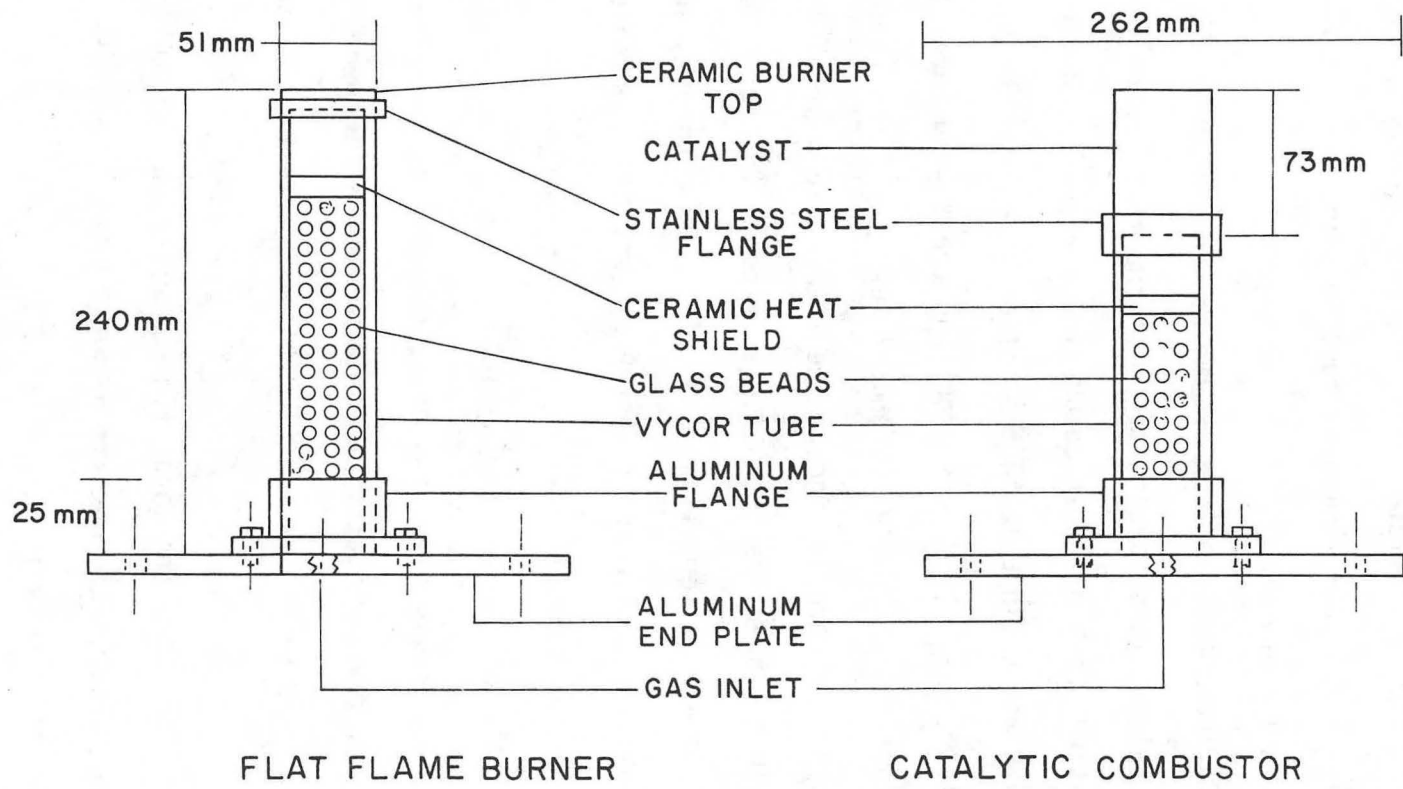
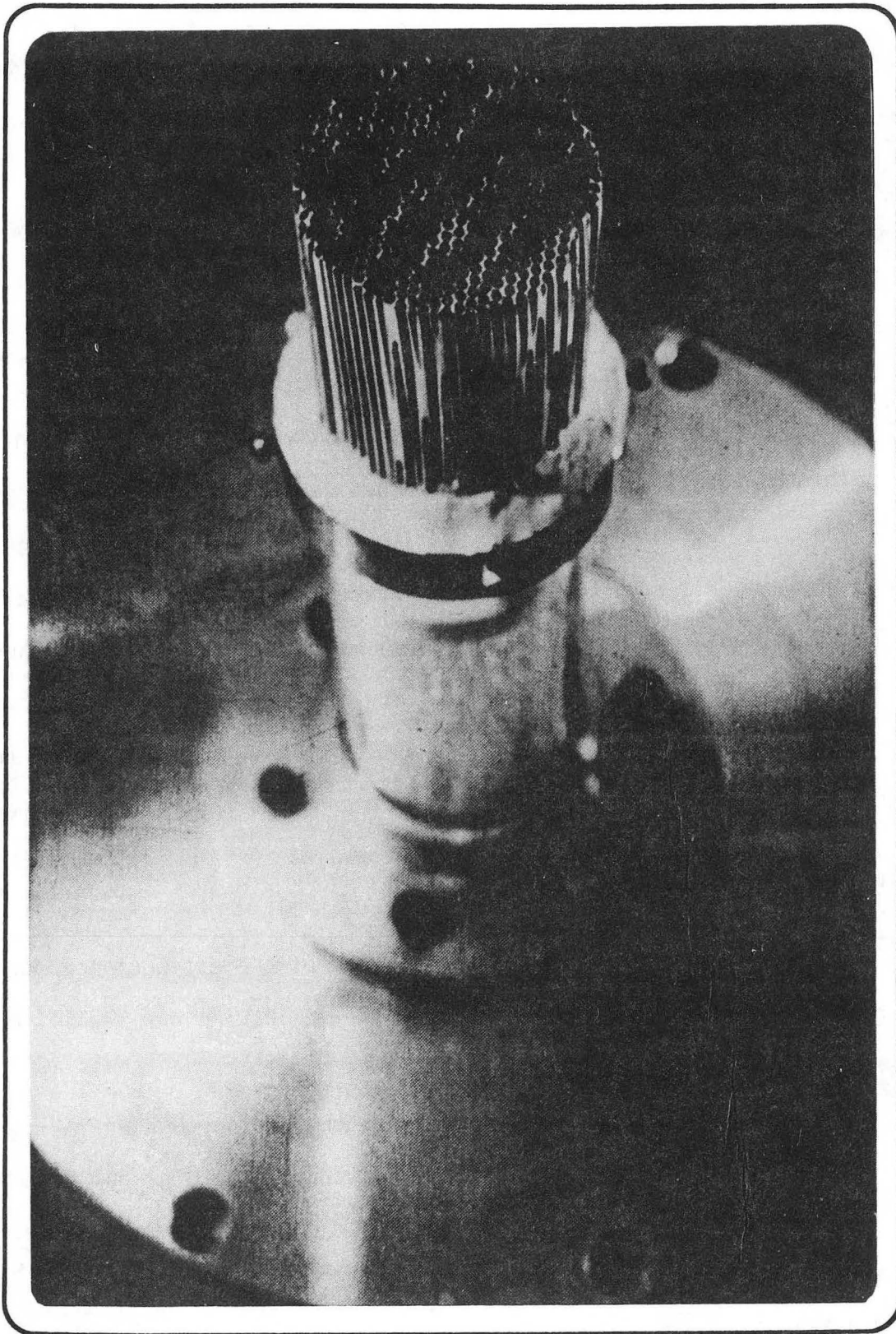

Figure 6-3. Comparison of the Flat Flame Burner and the Catalytic Combustor

available by Accurex/Aerotherm. Three thermocouples are imbedded in the catalyst, 18 mm from the centerline and 19, 36.5, and 56 mm from the upstream face. This approximately corresponds to positions one-quarter, one-half and three-quarters of the distance from the upstream to the downstream face of the catalyst. Previous investigations have shown that this is where the majority of the reaction takes place. In general, preheating of the inlet air leads to autoignition of the catalytic combustion process. In the present case, the inlet mixture was not preheated so another form of ignition had to be used. This catalytic combustor is very similar to an uncooled ceramic flat flame burner, and it was ignited in the same manner. With the reactant mixture flowing through the catalyst, a propane torch was held near the combustor exit and a flat flame was established above the downstream face of the catalytic combustor. Heat transfer from the flame to the combustor would gradually raise the surface temperature above the catalytic ignition temperature. The flame would self-extinguish as the fuel became consumed in the catalyst section. It was noted that the flame would extinguish first on the centerline, leaving a doughnut shaped flame. The radius of the extinguished portion of the flame gradually increased until the combustion was stabilized entirely within the catalyst section.

Several views of the catalytic combustor are shown in Fig. 6.4. Scanning electron micrographs of a section of the platinum coated ceramic which makes up the catalytic combustor are shown in Fig. 6-5. Platinum maps corresponding to several of the scanning electron micrographs are also included in Fig. 6-5. The SEM micrographs and platinum maps were made available by Tom Owens of the Air Force Rocket Propulsion Laboratory. The catalytic surface is observed to be relatively rough, containing irregular blisters. The platinum loading on these



XBB 770-11497

Figure 6-4a. Closeup View of the Catalytic Combustor, Also Showing the Vycor Tube Filled with Glass Beads, End Plate, and Flanges.

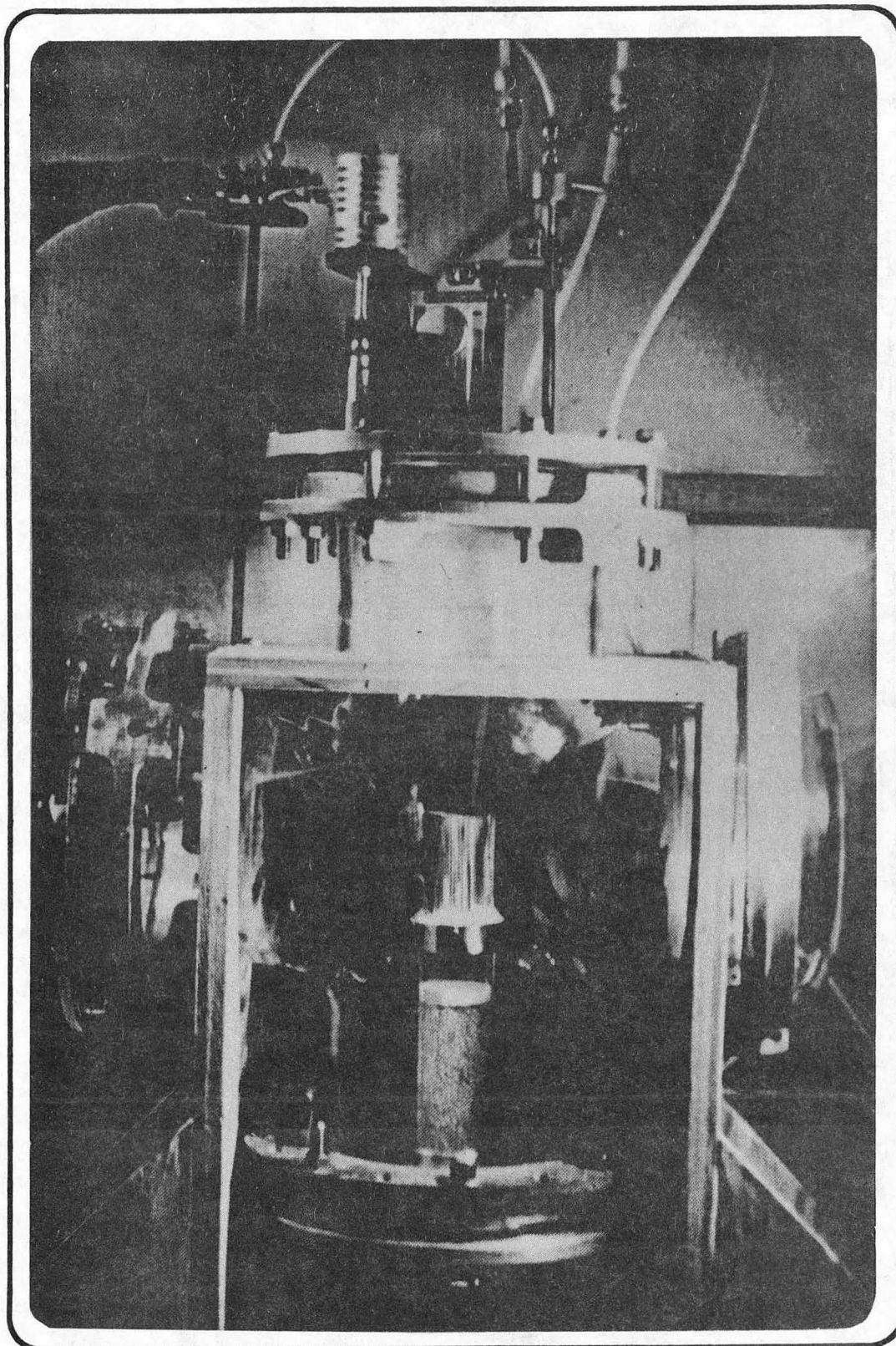

XBB 770-11496

Figure 6-4b. The Catalytic Combustor in the Glass Housing. The probe cooling sleeve, traversing mechanism, and cradle are also shown.

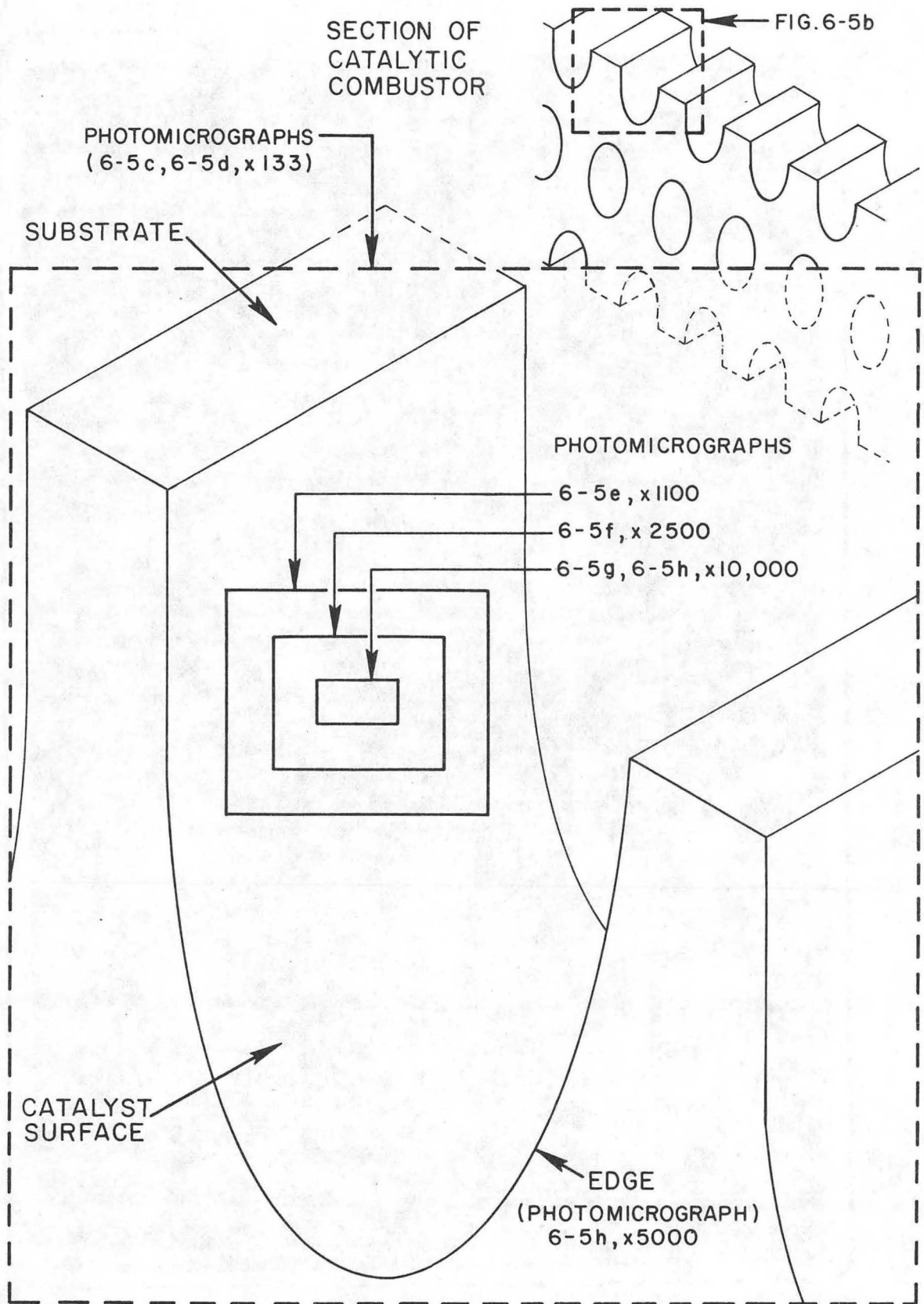
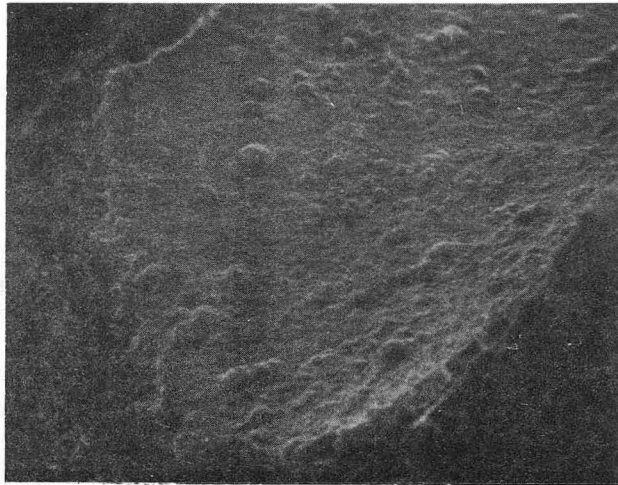
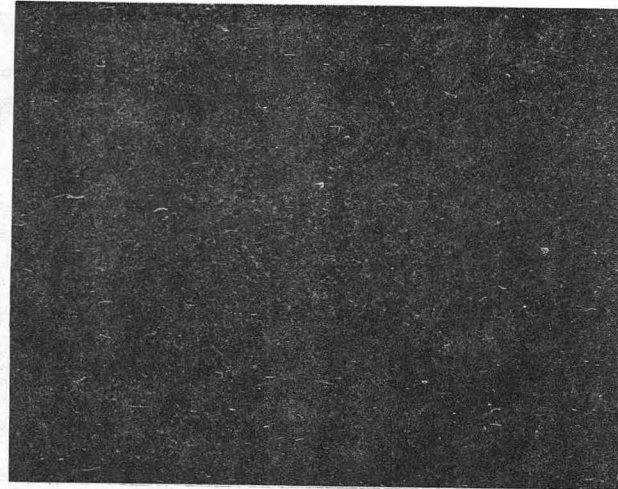

Figure 6-5. a) Drawing of a rectangular section of the catalytic combustor, showing the section of which 6-5b is an enlarged view.  
b) Enlarged drawing of a section of the catalytic combustor showing the approximate locations where Scanning Electron Micrographs 6-5 c-i were photographed.



6-5c. SEM of catalytic combustor x133



6-5d. Platinum map of 6-5c

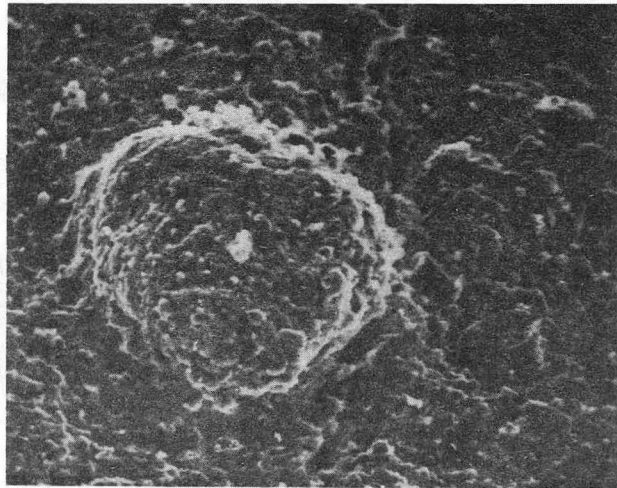

6-5e. SEM blowup of nodule in upper left quadrant of 6-5c x1100

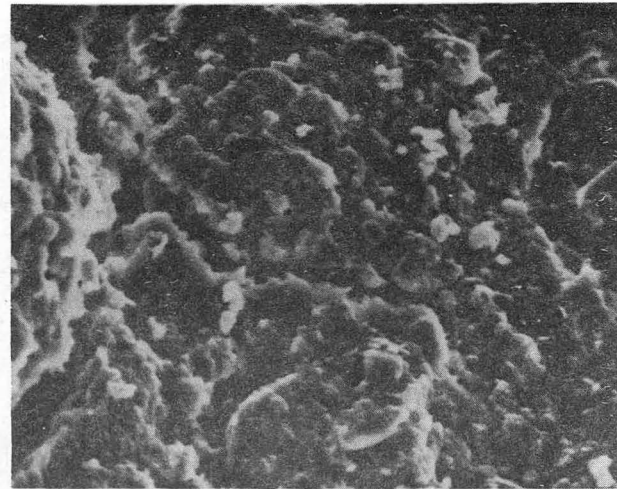

6-5f. SEM blowup of crack visible in 6-5e showing right side of nodule x2500

XBB 770-11500

00004901129

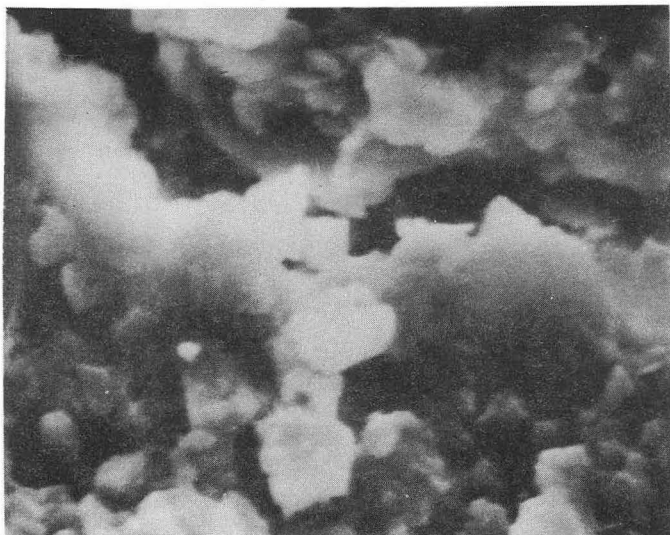

6-5g. Extreme blowup of the crack which runs left-to-right in 6-5f x10,000



6-5h. Platinum map of 6-5g

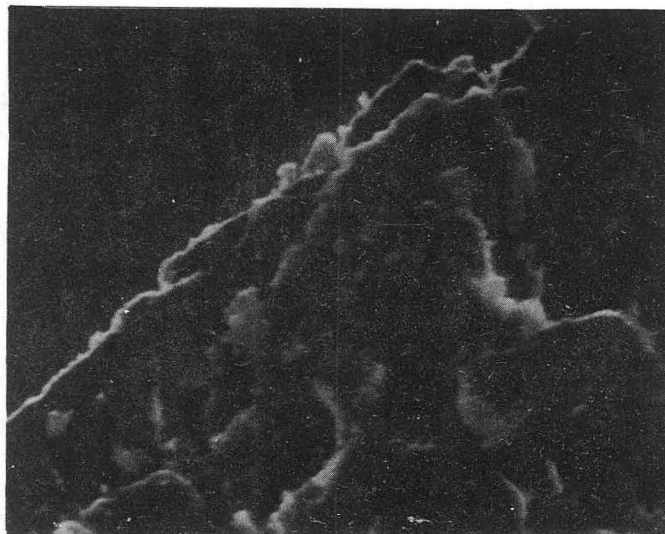

6-5i. View of edge of catalyst showing surface roughness x5000

blisters seems to be less dense than on the open areas, but because the surfaces which are mapped are not flat, the maps are subject to shadowing. It does appear that the platinum loading is fairly uniform except on the blisters.

Figure 6-6 is a picture of the probe traversing mechanism. In the vertical direction, a microscope stage provides coarse adjustment and motorized micro-positioning device provides fine adjustment. This motorized micropositioner is the Ardel Kinematic T-100M and allows steps as small as  $1 \mu$  to be traversed. It is governed by a controller designed and built by Al Shaw, the head electronics technician with the Department of Mechanical Engineering at the University of California, Berkeley. Manual traversing devices allow positioning in the other two degrees of freedom.

#### c. Probe and Sample Transfer System

Since late 1971, there has been general concern over probe effects on measurement of  $\text{NO}_x$  in combustion systems. At that time, Airesearch Manufacturing Company (1971) reported measuring significant concentrations of  $\text{NO}_2$  in the exhaust of gas turbines of their manufacture. As shown in Figure 4-1,  $\text{NO}_2/\text{NO}_x$  ratios as high as 80% could be encountered under combustion conditions which reflected gas turbine operation at idle. Previously, it had been generally accepted that  $\text{NO}_2$  constituted less than 5% of the total oxides of nitrogen in emissions from combustion systems (Heywood et al., 1971; Mellor, 1972). A later study by Matthews (1972) measured significant  $\text{NO}_2$  levels in a model gas turbine combustor, as shown in Figure 4-2. Schefer et al. (1973) report measuring high  $\text{NO}_2/\text{NO}_x$  ratios in turbulent diffusion flames and premixed opposed flow stabilized flames. Cernansky (1976) reports that significant concentrations of  $\text{NO}_2$  have been measured in the exhaust of diesel and spark ignition engines (Hilliard and Wheeler, 1974), gas turbine

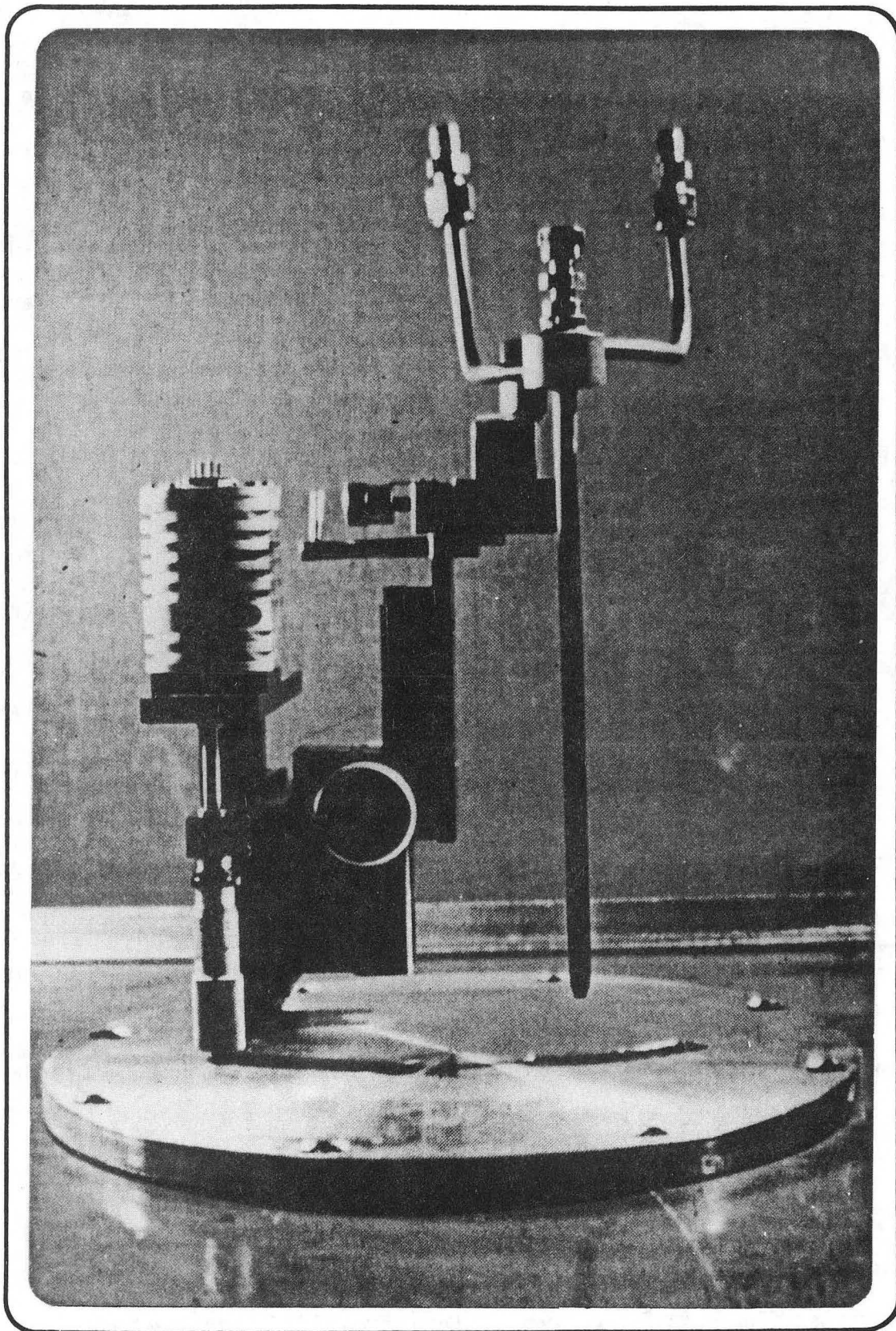

XBB 770-11595

Figure 6-6a. Probe Traversing Mechanism, Motor Drive, and Microprobe Cooling Sleeve Attached to the Top End Plate.

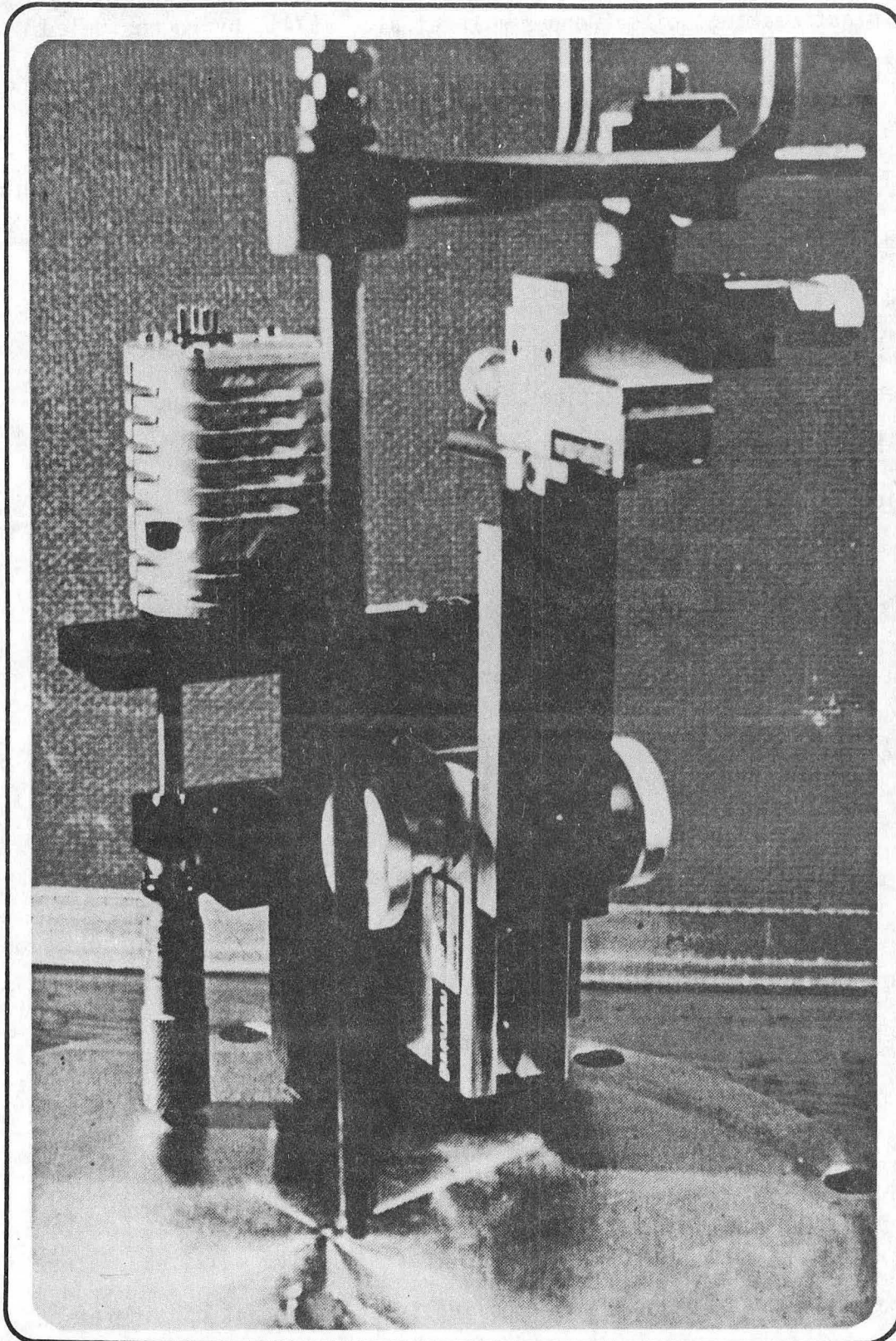

XBB 770-11499

Figure 6-6b. Another View of the Traversing Mechanism, Motor Drive, and Cooling Sleeve.

power plant peaking units (Coppersmith et al., 1974), hydrogen fueled vehicles, vehicles fueled with a blend of methanol and gasoline (Adelman, 1972), and a swirl stabilized combustor (Oven et al., 1977).

It has been postulated that these measurements of NO<sub>2</sub> are the result of NO<sub>2</sub> formation reactions in the probe rather than the actual presence of NO<sub>2</sub> in the flame. Probe reactions can occur either homogeneously or heterogeneously. Several researchers have suggested that the NO<sub>2</sub> may result from radical reactions (Allen, 1975; Cernansky and Sawyer, 1975; Malte and Pratt, 1973). This would occur primarily through reactions such as



in the gas phase and heterogeneous reactions such as

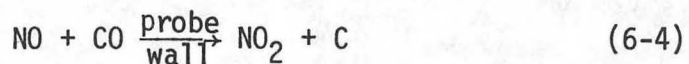

These reactions have been reviewed by Benson et al. (1976). In addition, theoretical and/or experimental studies of probe effects on NO<sub>x</sub> measurement have been carried out by Yanagi (1977), Amin (1977), Kramlich (1976), Schefer et al (1973), and England et al. (1973). Several general conclusions may be drawn from these studies. NO<sub>x</sub> transformation is a function of the particular combustion system under investigation, especially with respect to probe wall temperature and oxygen concentration. Probe cooling is an important consideration. Probe material, surface area, and sampling pressure are important variables. It appears that many of the reactions which have been

postulated to explain  $\text{NO}_2$  formation in probes may also lead to  $\text{NO}_2$  formation in flames, particularly turbulent flames where hot combustion products may be rapidly cooled.  $\text{NO}_2$  measurements appear to be an artifact of the sampling system in some cases but the result of the presence of  $\text{NO}_2$  in the flame in other cases. This last case is illustrated in Figure 4-2, where the maximum  $\text{NO}_2$  levels are greatest at the combustor exit. At this location, radical concentrations should be very low.

A probe of the type used by Schefer (1976) was chosen for this experiment. As shown in Figure 6-7, it is an aerodynamically quenched quartz microprobe which is housed in a water cooled stainless steel sleeve. Quartz has been shown to be less catalytic than the other commonly used probe material, stainless steel. Cooling is considered to inhibit many  $\text{NO}_x$  transformation reactions. The probe pressure was maintained at less than a half an atmosphere to inhibit probe reactions and eliminate water condensation.

The sample transfer lines were obtained from Technical Heaters, Inc. The use of these 1/8" OD heated teflon lines was intended to minimize adsorption of the nitrogenous species, such as  $\text{NH}_3$ , which are known to have an affinity for unheated surfaces.

#### d. Measurement of NO by Chemiluminescent Analysis

In recent years, chemiluminescent analysis has become a widely used method for determination of low concentrations of gas phase nitric oxide and nitrogen dioxide. This popularity is generally attributable to the ease of use, sensitivity, and linearity normally associated with commercially available chemiluminescent analyzers. However, several problems may be encountered during the use of these instruments.

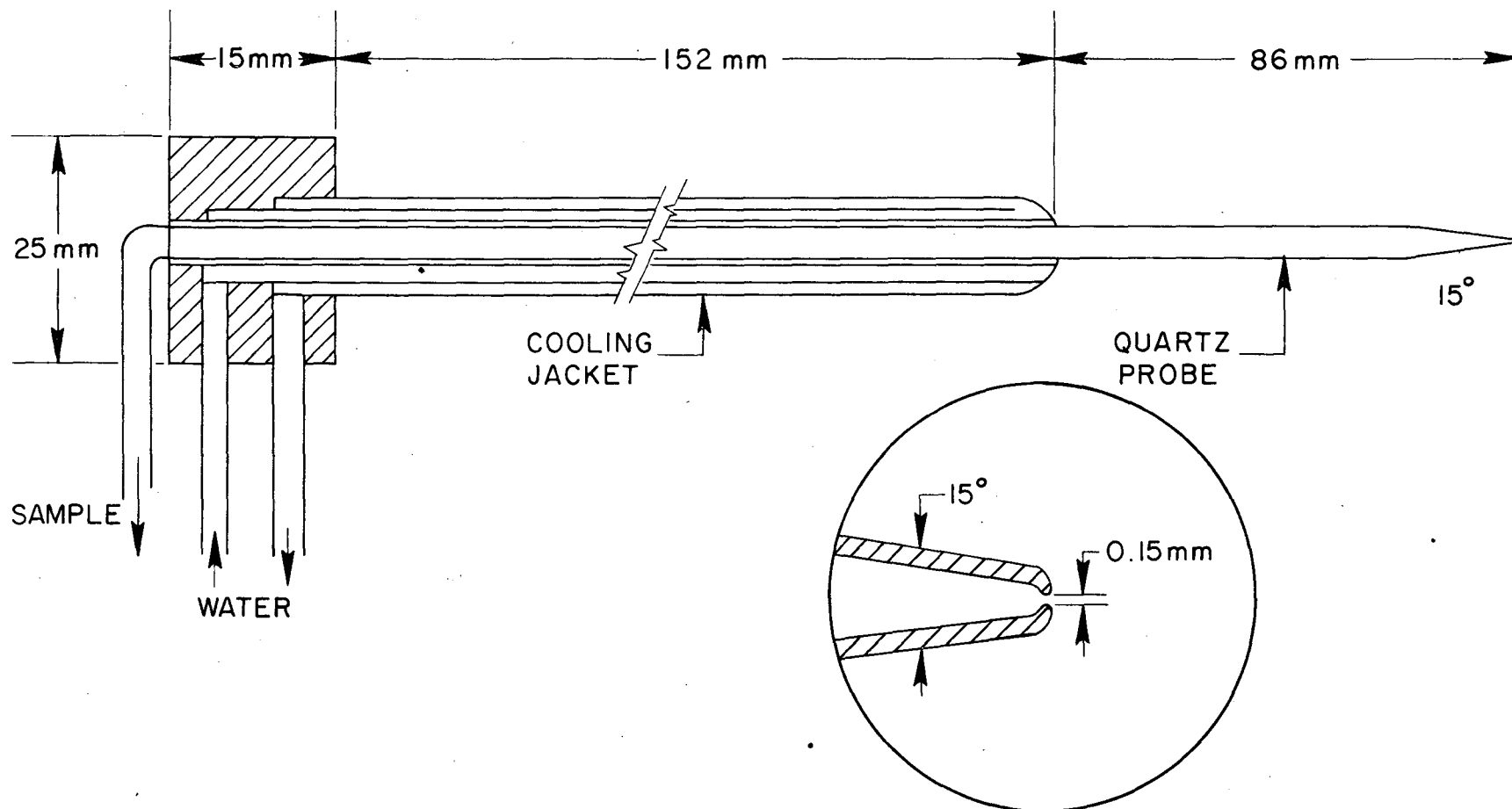

Figure 6-7. Quartz Gas Sampling Microprobe and Cooling Sleeve (Schefer, 1976).

Difficulties which are related to measurements of  $\text{NO}_x$  in fuel rich combustion systems have been previously reported in the literature (Tuttle et al., 1974; Turner, 1974; Allen, 1975; and Siewart, 1975). Two additional factors which may affect the quantification of NO and  $\text{NO}_2$  in combustion products when using chemiluminescent analysis are the dependence of the chemiluminescent intensity on competing third body quenching reactions and the possible conversion of various low molecular weight nitrogen containing compounds (in addition to  $\text{NO}_2$ ) to NO in the commercial  $\text{NO}_x$  converters. Because accurate determination of the concentration of NO in combustion products is essential to this investigation, these last two factors were studied in preliminary experiments (Matthews et al., 1977).

This research revealed that significant errors would be encountered when using chemiluminescent analysis to quantify NO in combustion products. These errors are attributable to the difference between the calibration gas ( $\sim 100\% \text{N}_2$ ) and the sampled gases (containing  $\text{H}_2\text{O}$ ,  $\text{CO}_2$ , CO,  $\text{H}_2$ , Ar, etc.) and is referred to as the relative third body quenching efficiency effect. Matthews and coworkers developed a set of equations which allowed calculation of the actual [NO] given the indicated [NO] and the mole fractions of the important third bodies. In this investigation, the important third bodies were  $\text{CO}_2$ ,  $\text{H}_2\text{O}$ , and Ar. Because Ar is less efficient than  $\text{N}_2$  in quenching the relevant photochemical reaction and  $\text{CO}_2$  and  $\text{H}_2\text{O}$  are more efficient (see Figure 6-8) and because Ar is the major species in the products of combustion in this experiment, the relative quenching efficiencies compensated for each other. This resulted in the difference between actual and indicated NO concentrations never exceeding 5%. Nevertheless, the

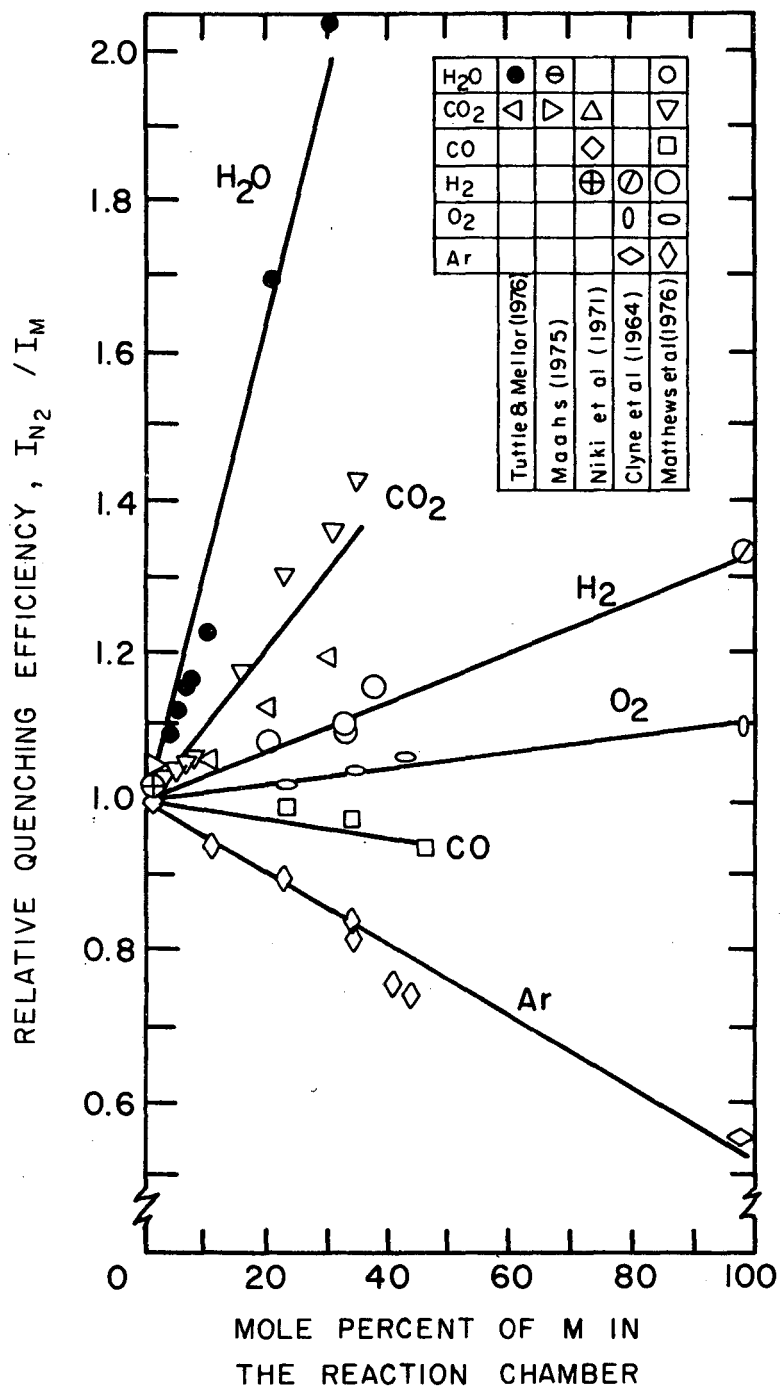

Figure 6-8. Relative Quenching Efficiencies of Common Third Bodies for Chemiluminescent NO Analysis (Matthews et al., 1977).

actual [NO] is always reported unless otherwise specified.

The other result of the preliminary investigation was the conclusion that a wide variety of N-species could be converted to NO in commercial NO<sub>2</sub>-to-NO converters. For this reason, the chemiluminescent converter which is normally used to quantify NO<sub>2</sub> could not be used in this experiment because HCN, NH<sub>3</sub>, and other N-species were expected to be present in the combustion products.

As noted by Sawyer et al. (1976), the commercial chemiluminescent analyzer (CLA) is equipped with a sample bypass system. This system is designed to exhaust any excess sample which flows into the CLA. However, if extremely low sample flow rates are encountered, as is the case when sampling through an aerodynamically quenched microprobe, the flow through the bypass system could reverse directions and dilute the sample. For this reason, the sample bypass system and sample capillaries were disconnected. A valve at the inlet to the CLA was used to maintain the reaction chamber pressure at 15 torr, the normal operating pressure under factory-equipped conditions. This procedure insured that the ratio of sample to ozonated oxygen flowrates into the reaction chamber was a known constant, 0.4545. The importance of this number, the dilution constant, is discussed by Matthews et al. (1977). It is used in the calculations which compensate for differences in relative quenching efficiencies.

An auxilliary pump was used to maintain the probe pressure below a half an atmosphere. It was found that the indicated [NO] was not dependent on probe pressure for pressures less than  $0.5 \times 10^5$  Pa, indicating that there were no significant reactions occurring in the sampling system.

e. Measurement of  $N_2$  by gas chromatography with thermal conductivity detection

Molecular nitrogen was detected using an HP5750 dual column gas chromatograph with a thermal conductivity detector. The column used was a 12' x 1/4" Molecular Sieve 5A which preceded an 18' x 3/16" Molecular Sieve 5A column. The column was maintained at ambient temperature. This combination gave a 420 second separation time between the  $O_2/Ar$  peak and the  $N_2$  peak. The large separation was necessary because the substantial amount of Ar in the exhaust ( $\sim 80\%$ ) would tend to mask the very small  $N_2$  peak with smaller separation times. Calibration of the system with He in Ar mixture gases revealed a minimum detectable limit of slightly less than 100 ppm. Unfortunately, a small air leak developed while taking  $N_2$  data from the combustion systems, making quantification impossible. The attempt to quantify  $N_2$  was abandoned because of insufficient time to correct the leakage problem.

f. Detection of other low molecular weight N-species

Low molecular weight nitrogenous species other than NO and  $N_2$  were detected gas chromatographically and colorimetrically. The effluent from the HP5750 GC was analyzed using thermal conductivity and chemiluminescent analyzers in series. Air was added between the TC and the CLA and a portion of the air/effluent mixture was passed through the stainless steel  $NO_x$  catalyst in the TECO 12A. The  $NO_x$  converter temperature was maintained at 1175 K (900 C). The remainder of the GC effluent was bypassed using a sample splitter. The CLA reaction chamber pressure was maintained at 14 torr. Heated teflon tubing was used to interface the GC and the CLA. A 6' x 3/16" Porapak Q

column was used. The manufacturers of this packing material have shown that it can be used to separate methyl cyanide, vinyl cyanide, nitroparaffins, nitrous oxide, amines and  $\text{NO}_x$ . Under certain operating conditions, reverse flow would develop in the sample splitter system. Because of insufficient time to optimize the interface to alleviate this problem, it was impossible to quantify the concentrations of the other low molecular weight nitrogenous species which were detected.

A dry chemical colorimetric method was also used to detect  $\text{NH}_3$ , HCN,  $\text{NO}_2$ , and vinyl cyanide. Quantitative determination was not possible using this method. The  $\text{NO}_2$  tubes are not felt to be reliable because NO, a known interferent, was never detected in the combustion emissions using this technique.

## CHAPTER 7

### Results of the Flat Flame Burner Study

This investigation of fuel nitrogen conversion in premixed flat flame combustion is an extension of the related work by Sawyer et al. (1976) and will draw from that work to a large extent.

In that investigation, fuel nitrogen conversion at  $\phi = 1.58$  was studied. Minor modifications in the combustion system constrain this burner to operation near an equivalence ratio of 1.25 for flame temperatures compatible with material limitations imposed by the proposed comparison with the catalytic combustor. Sawyer and coworkers characterized the flat flame burner by measuring axial and radial temperature profiles and axial  $\text{CO}_2$ , CO, and NO profiles. A preliminary nitrogen balance across the flame was also reported.

#### 7.1 Experimental Results

This investigation is intended to study the effect of fuel nitrogen concentration and theoretical flame temperature on fuel nitrogen conversion. Because minor modifications have been made in the burner and a different equivalence ratio is to be studied, the post flame zone was characterized again. However, Sawyer et al. (1976) demonstrated that profiles of T,  $\text{CO}_2$ , CO, and NO had similar trends for ceramic flat flame burners. Therefore, only axial NO profiles are researched in an effort to find a position in the post flame zone where gradients are shallow. This axial position will then be used to measure the fuel

nitrogen yield as a function of equivalence ratio and adiabatic flame temperature.

Axial profiles of NO yields were used to determine a region of shallow gradients. Figure 7-1 presents indicated NO yields for NO and  $\text{NH}_3$  addition for various adiabatic flame temperatures. The fuel nitrogen fraction (concentration) is 5% of the total fuel ( $\text{NO} + \text{C}_3\text{H}_8$  or  $\text{NH}_3 + \text{C}_3\text{H}_8$ ) by weight. The yields are not corrected for the relative third body quenching effect because of uncertainties about sample composition in the flame zone. Furthermore, relative third body quenching efficiencies have not been reported for polyatomic molecules such as the hydrocarbons which might be encountered in the flame and preflame zones. The NO yield profiles in Figure 7-1 are relatively flat from an axial position of about 4000  $\mu$  to about 6000  $\mu$  above the burner for all the flame temperatures studied. It is believed that the temperature gradually increases at distances greater than 6000  $\mu$  because of mixing with the surrounding air. The products of fuel rich combustion contain significant concentrations of CO and  $\text{H}_2$ . Mixing with the surrounding air leads to oxidation of these species and a consequent rise in temperature. Similar plots for variation in fuel nitrogen concentration again reveal a flat profile between about 4000 and 6000  $\mu$ , independent of [FN]. Therefore, the position on the centerline 5000  $\mu$  from the burner top was chosen as a reference for the remainder of the data presented in this chapter.

Figure 7-2 presents the data of Figure 7-1 rearranged to produce a plot of NO yield (fraction of fuel nitrogen converted to NO) versus adiabatic flame temperature at constant equivalence ratio and fuel nitrogen concentration. The NO yield is seen to be very weakly dependent

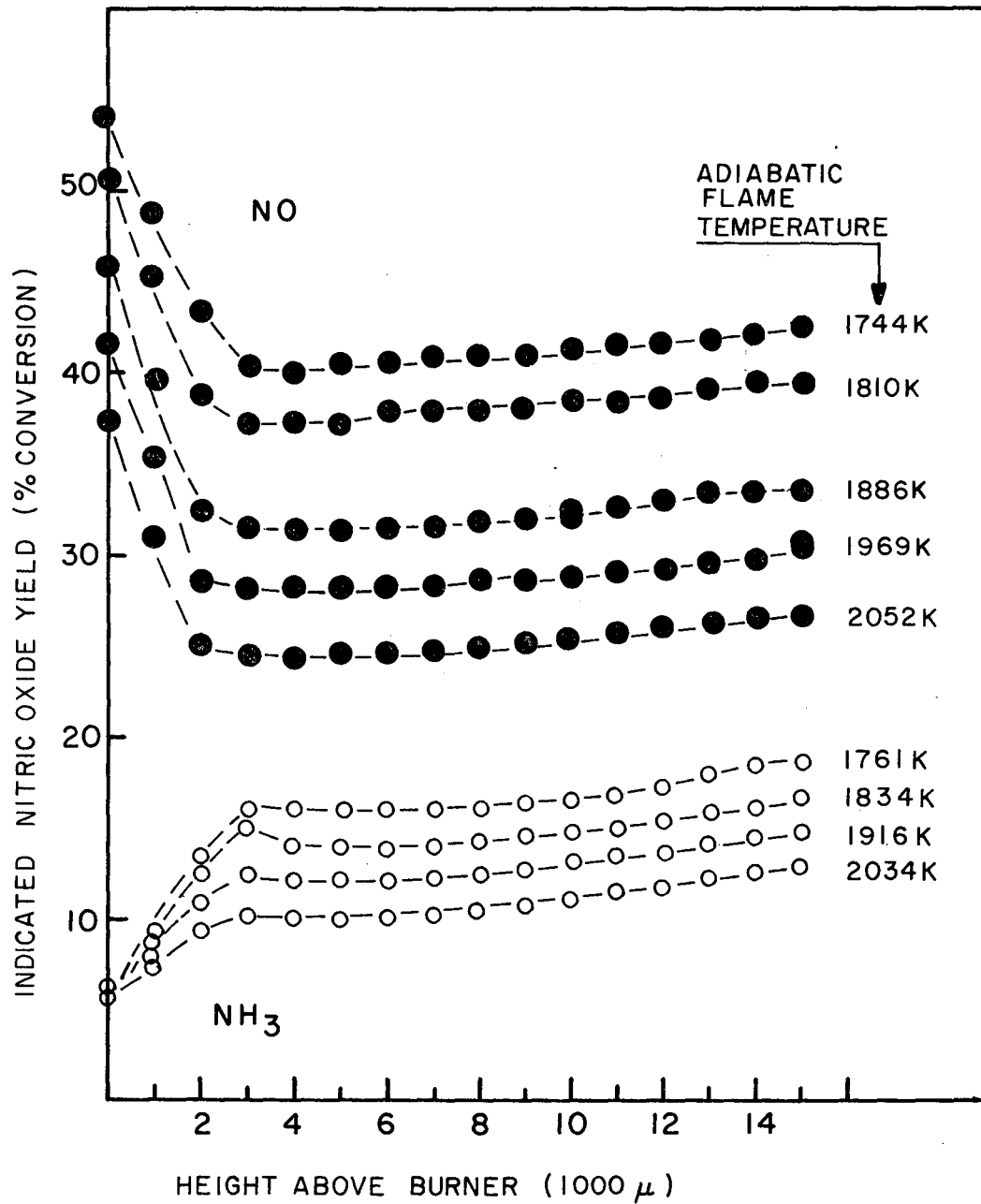

Figure 7-1. Indicated NO Profiles Above the Flat Flame Burner for Various Flame Temperatures. NO and NH<sub>3</sub> were added to yield a fuel nitrogen concentration of 5.0 wt. % of the fuel.

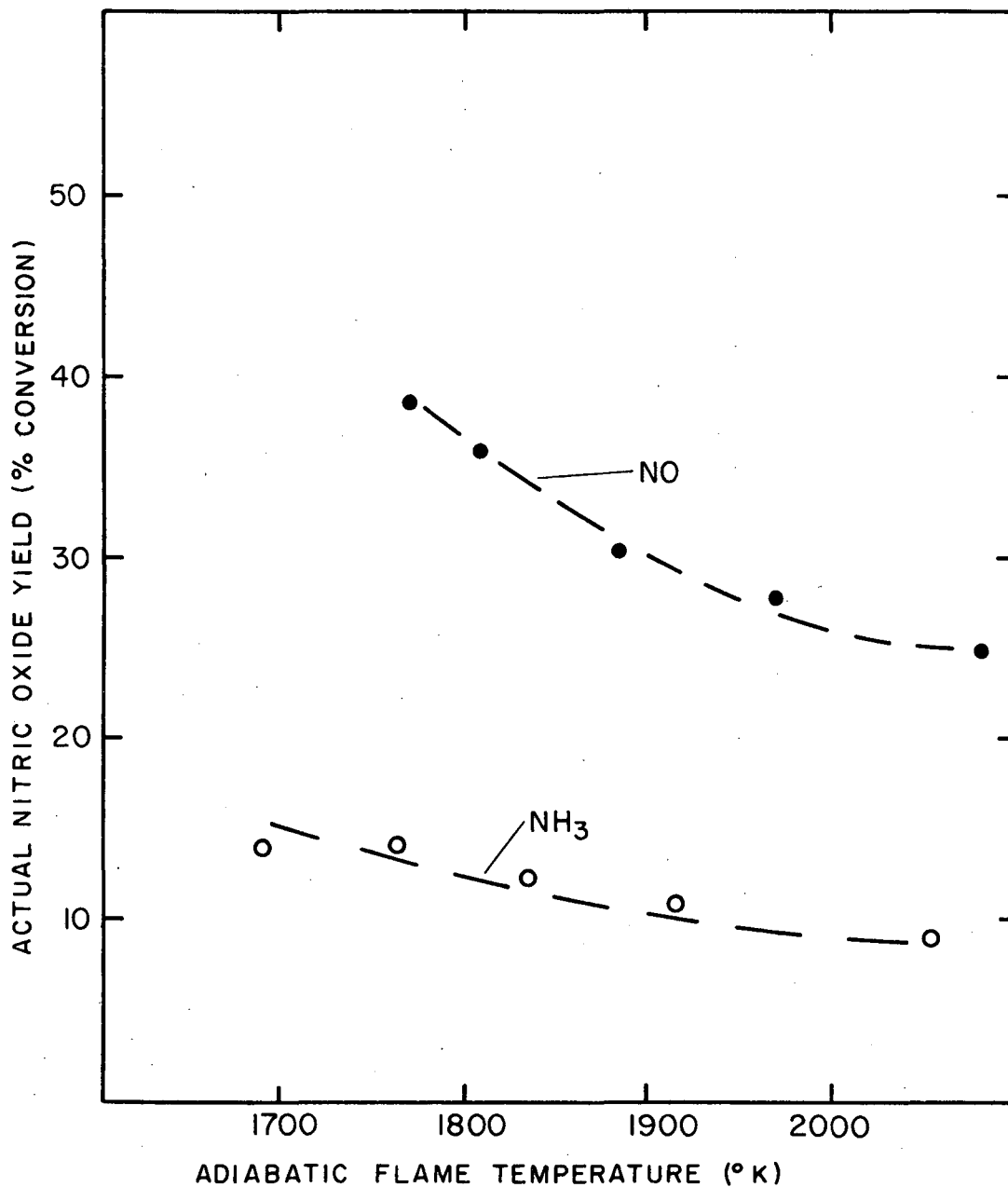

Figure 7-2. Effect of the Adiabatic Flame Temperature on the Conversion of Fuel-N to NO at Constant Equivalence Ratio and Fuel-N Fraction for Fuel Rich Homogeneous Combustion.  
 $\phi_{\text{NO}} = 1.23$ ,  $\phi_{\text{NH}_3} = 1.25$ , [FN] = 5.0 wt. % of fuel.

on temperature. This observation is in agreement with results obtained by previous researchers. The equivalence ratio was maintained at 1.23 for NO addition and 1.25 for NH<sub>3</sub> addition. The fuel nitrogen concentration was 5.0% by weight of the fuel.

The effect of fuel nitrogen concentration on NO yield is presented in Figure 7-3. In agreement with the results reported by previous researchers, the NO yield is observed to decrease with increasing fuel nitrogen concentration. There is relatively little difference between the yields of NO and NH<sub>3</sub> at low concentrations. The data for NO addition were taken at an equivalence ratio of 1.23 and an adiabatic flame temperature of 2069 K. For NH<sub>3</sub>,  $\phi = 1.25$  and  $T_{AD} = 2049$  K.

Gas chromatographic analysis revealed the presence of NH<sub>3</sub> and NO<sub>x</sub> in the FFB exhaust. Two other unidentified N-species were also noted. The retention times for the unidentified peaks did not match the expected elution times for N<sub>2</sub>O, methyl cyanide, vinyl cyanide, or nitroparaffins but may have been amines. If these species were present, the levels must have been below the detectable limits. The colorimetric technique also indicated the presence of small concentrations of NH<sub>3</sub>. In addition, low concentrations of vinyl cyanide and HCN were tentatively noted. NO<sub>2</sub> was not detected.

## 7.2 Discussion and Summary

The fuel nitrogen investigation using the flat flame burner quantified the effect of fuel nitrogen fraction and adiabatic flame temperature on the NO yield. In agreement with the results reported by previous researchers, the NO yield is observed to decrease with increasing fuel nitrogen concentration. The NO yield is seen to be

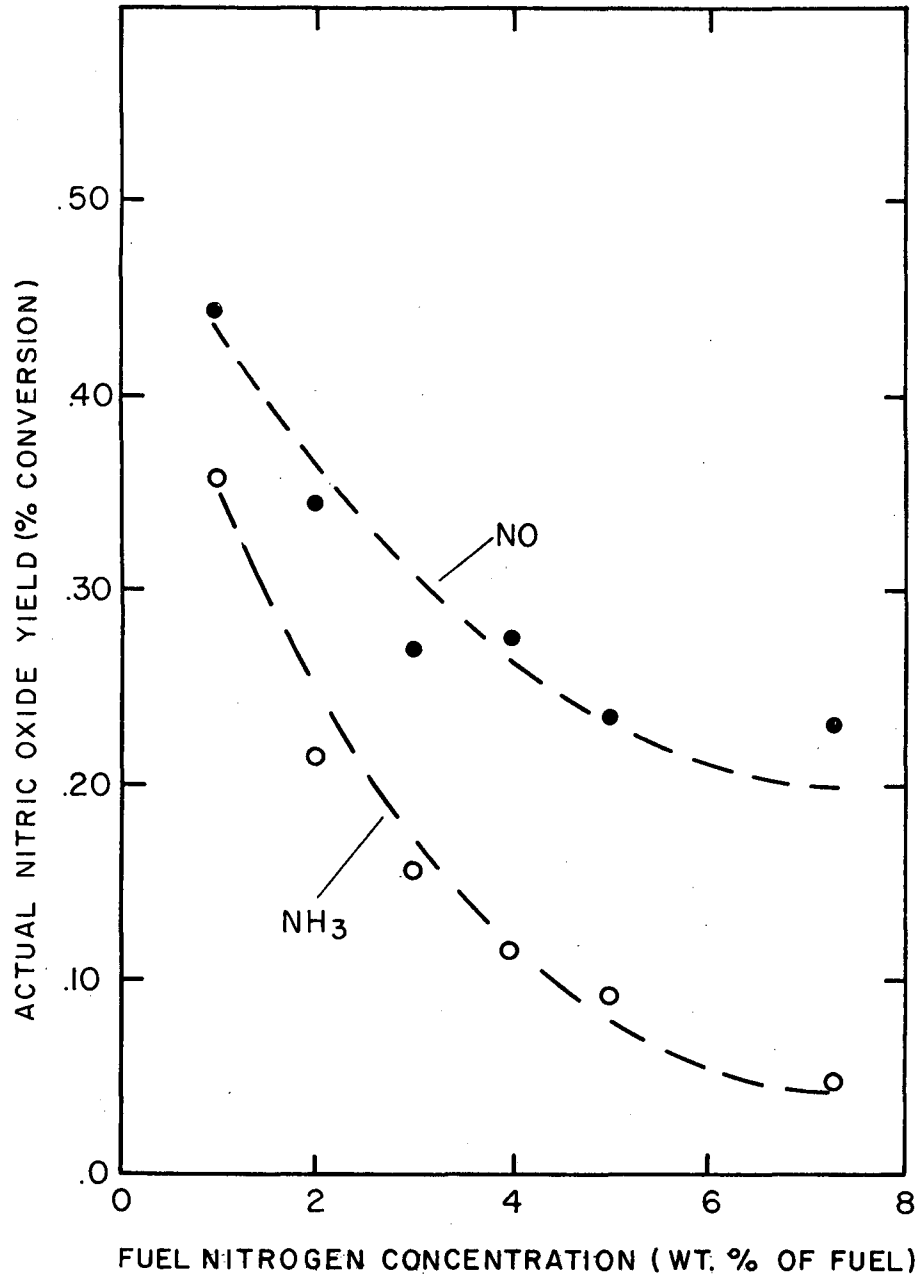

Figure 7-3. Effect of Fuel-N Concentration on the Conversion of Fuel-N to NO at Constant Equivalence Ratio and Adiabatic Flame Temperature for Fuel Rich Homogeneous Combustion. NO addition:  $\phi = 1.23$ ,  $T_{AD} = 2069$  K. NH<sub>3</sub> addition:  $\phi = 1.25$ ,  $T_{AD} = 2049$  K.

very weakly dependent on the flame temperature and decreases slowly with increasing temperature. The NO yield is smaller when  $\text{NH}_3$  is the model fuel nitrogen compound than when NO is the fuel-N species. Vinyl cyanide,  $\text{NO}_x$ , NHC, and  $\text{NH}_3$  were identified in the combustion products. The data obtained using this homogenous combustion system are of particular interest when compared to the results obtained using the catalytic combustor.

## CHAPTER 8

Results of the Catalytic Combustion Study

One major goal was to gather information about lean, stoichiometric, and rich catalytic combustion. The effect of equivalence ratio, adiabatic flame temperature, and fuel nitrogen concentration on fuel nitrogen conversion are presented in this chapter. In addition, the effect of equivalence ratio on measured temperatures, CO, CO<sub>2</sub>, UHC's and combustion efficiency are related.

8.1 Experimental Results

One advantage of using an O<sub>2</sub>/Ar mixture as the oxidant instead of air is that it allows investigation of catalytic combustion in a range of equivalence ratios which includes stoichiometric,  $\phi = 1.0$ . The melting point of this combustor is approximately 1420 K, a lower temperature than the temperature produced by fuel/air combustion under stoichiometric conditions. However, preliminary studies indicated that the temperatures produced during catalytic combustion under the conditions used in this study were much lower than the corresponding adiabatic flame temperatures. This is probably the result of radiation heat loss from the upstream face and additional heat loss through the sides of the combustor. Recall that the thermocouples were located near the periphery of the combustor. Figure 8-1 depicts the temperature distribution in the catalyst as a function of equivalence ratio. The temperature of the upstream face was determined using an optical pyrometer. During the course of the experiment

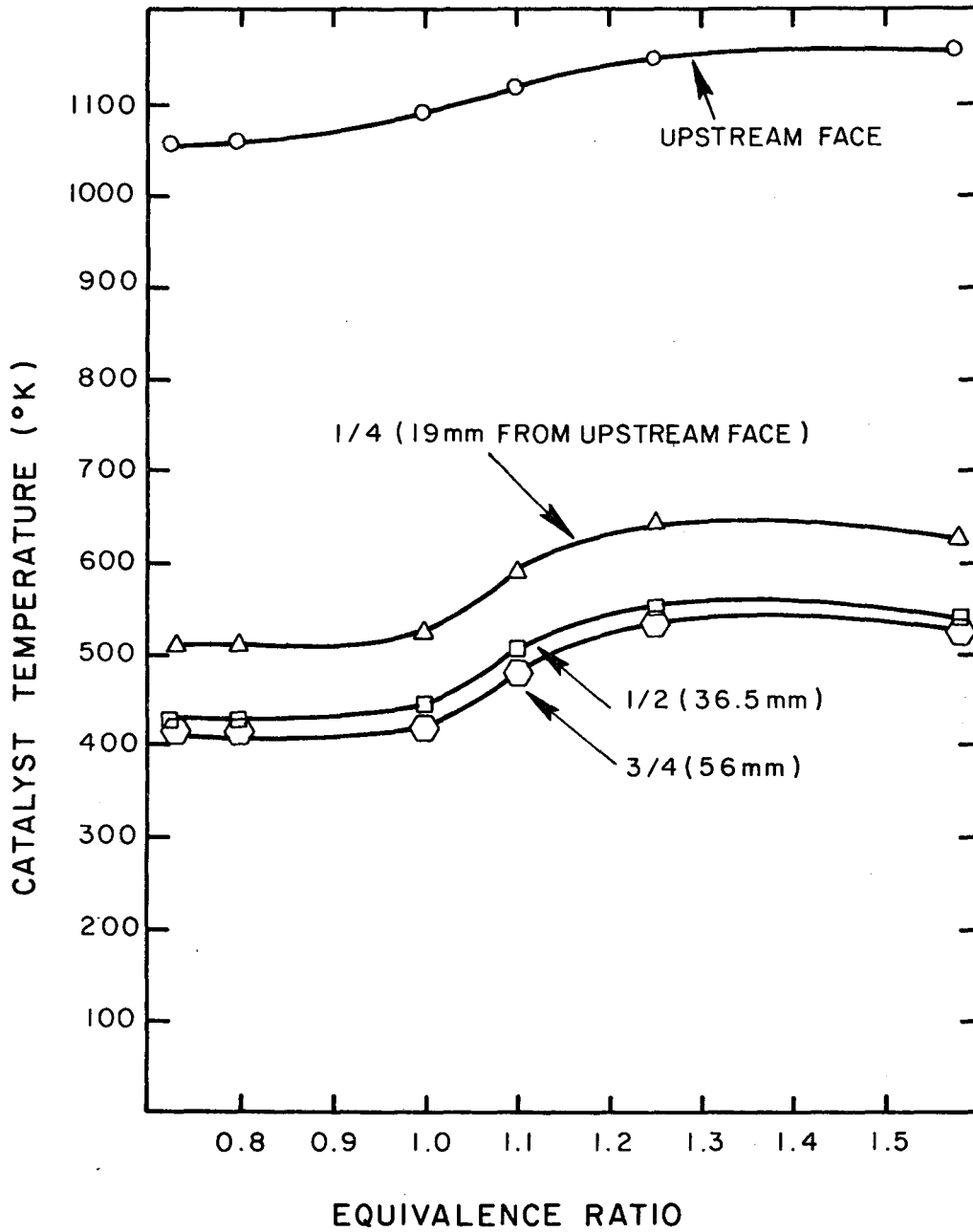

Figure 8-1. Temperature Distribution in the Catalyst as a Function of Equivalence Ratio at Constant Adiabatic Flame Temperature (2020 K).

it was noted that the radiation from the upstream face of the catalyst was visibly more intense during fuel rich combustion. The curves in Figure 8-1 indicate that the temperature profile is very flat throughout the last half of the catalytic combustor.

The combustion efficiency was calculated from the measured concentrations of CO, CO<sub>2</sub>, and UHC's. CO and CO<sub>2</sub> were quantified using NDIR's, and UHC's were measured with an FID. The results of the measurements are presented in Figure 8-2. Calculated equilibrium concentrations of CO and CO<sub>2</sub> are shown (dashed lines) for comparison. Sawyer et al. (1976) noted that CO and CO<sub>2</sub> were emitted from a homogeneous combustion system (a flat flame burner) in concentrations which did not differ significantly from equilibrium predictions under fuel rich conditions. For convenience, it may be assumed that the dashed curves in Figure 8-2 approximately represent homogeneous combustion while the solid curves depict trends observed during catalytic combustion. It is seen that the CO emitted from the catalytic combustor is much lower than predicted equilibrium values for all equivalence ratios investigated. For fuel rich combustion, CO<sub>2</sub> is emitted at levels which are more than two times equilibrium. Measured UHC's (methane equivalent) decrease near stoichiometric and increase as the combustion process becomes richer. Of course, no unburned hydrocarbons are predicted for equilibrium conditions. An 85 - 95% carbon balance was obtained for all equivalence ratios. The difference between the measured and equilibrium concentrations may be attributable to the combustion temperature being much lower than the theoretical adiabatic flame temperature.

The combustion efficiency may be generally defined as the ratio

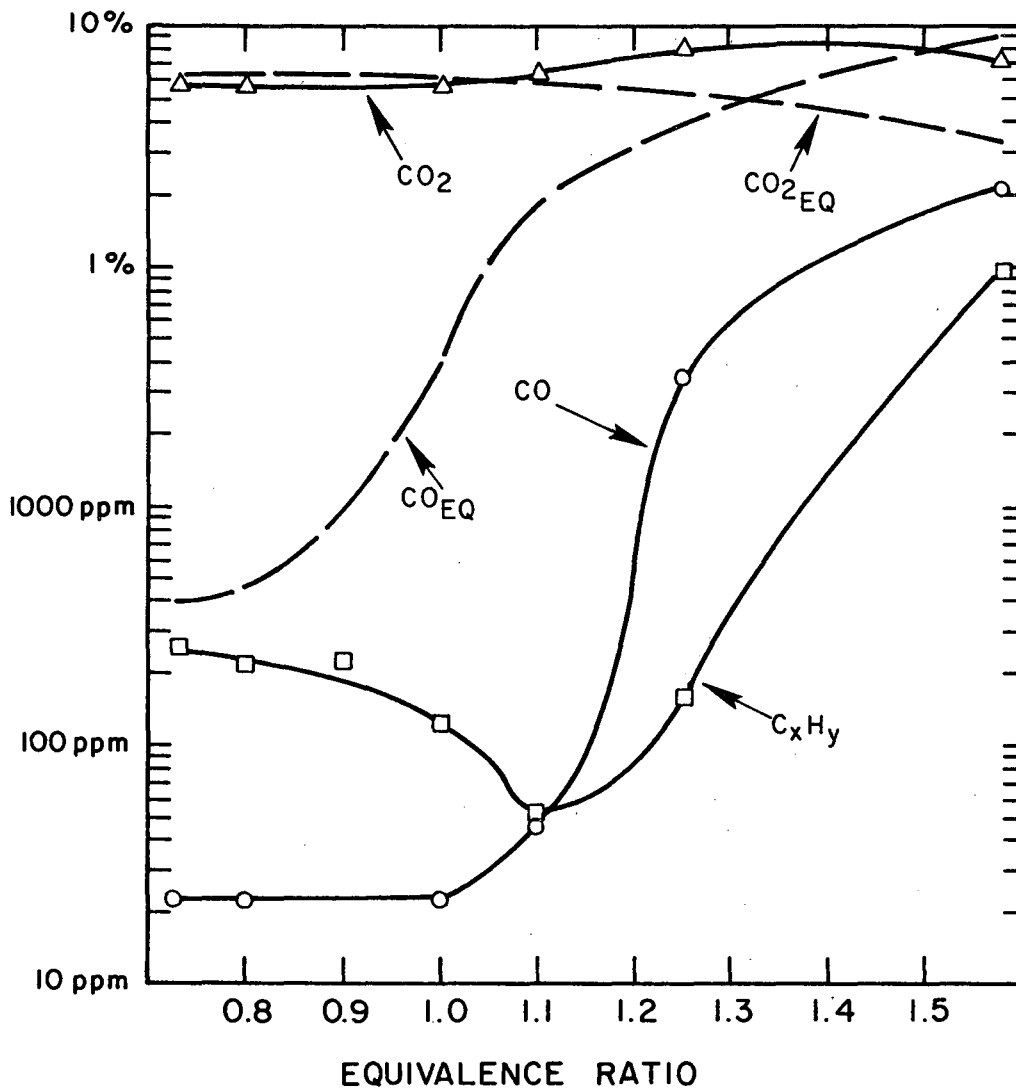

Figure 8-2. Comparison of Equilibrium and Measured Concentrations of CO, CO<sub>2</sub>, and C<sub>x</sub>H<sub>y</sub> as a Function of Equivalence Ratio.

of the actual enthalpy released to the enthalpy which would be released during complete combustion. Complete combustion implies that the sole products are  $\text{CO}_2$  and  $\text{H}_2\text{O}$  (and inerts, if any). In the fuel rich case, it is assumed that the excess propane carries through into the products without reacting. Measured unburned hydrocarbons are converted to a propane equivalent and it is assumed that hydrogen thus bound is not available for the formation of  $\text{H}_2\text{O}$ . The results of these calculations are presented in Figure 8-3. Measured combustion efficiency is graphically compared to the combustion efficiency for equilibrium products as a function of equivalence ratio in this figure. The catalytic combustor exhibits relatively high combustion efficiency for lean and stoichiometric combustion, though not as high as equilibrium products would show. However, for fuel rich operation, the combustion efficiency is much higher for catalytic combustion than for equilibrium conditions. This is because of the much higher  $\text{CO}_2$  and lower  $\text{CO}$  in the measured products in comparison to the equilibrium values.

Figure 8-4 is a plot of the  $\text{NO}$  yield as a function of equivalence ratio at constant temperature. The fuel nitrogen concentration was 5%. For  $\text{NO}$  addition, the calculated adiabatic flame temperature was 2024 K and for  $\text{NH}_3$  was 2015 K. There is not a large effect due to the type of model fuel nitrogen compound ( $\text{NO}$  or  $\text{NH}_3$ ). However, it is notable that the  $\text{NO}$  yield using  $\text{NH}_3$  as the model fuel nitrogen compound is higher than for  $\text{NO}$  as the model fuel-N species. The opposite was the case for gas phase combustion, as illustrated in Figures 7-2 and 7-3.

Figure 8-5 shows the effect of fuel nitrogen concentration on

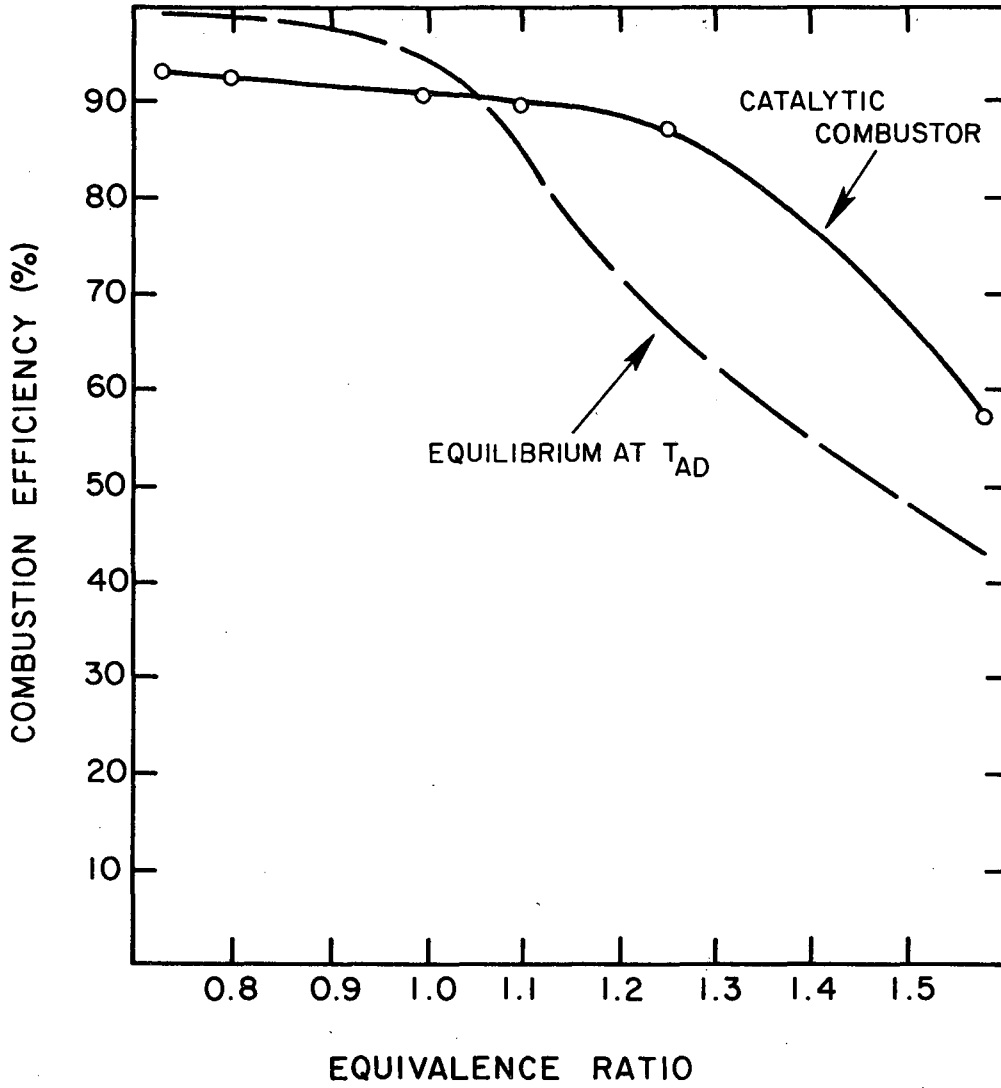

Figure 8-3. Combustion Efficiency as a Function of Equivalence Ratio.

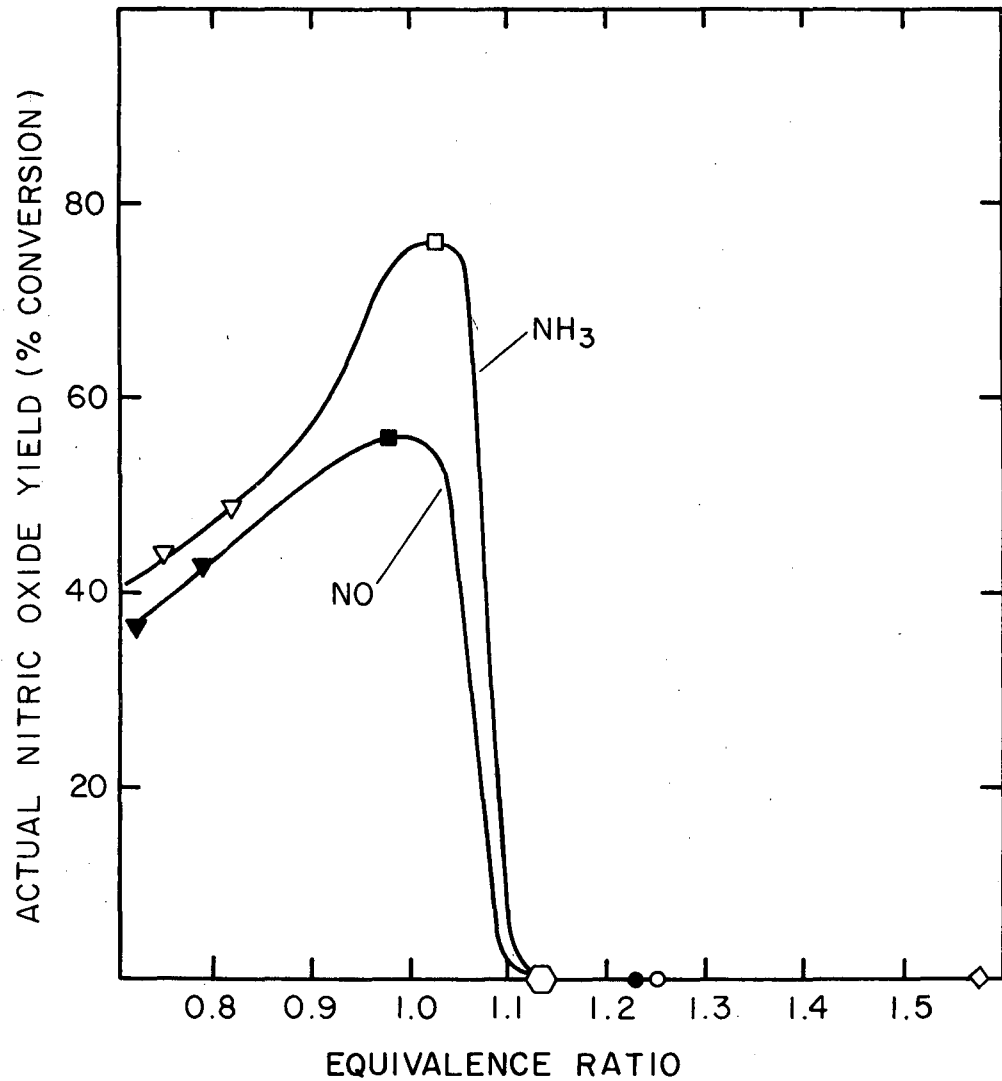

Figure 8-4. Effect of Equivalence Ratio on Conversion of Fuel-N to NO at Constant Adiabatic Flame Temperature and Fuel-N Concentration for Catalytic Combustion. [FN] = 5.0 wt. % of fuel,  $T_{NO} = 2024$  K,  $T_{NH_3} = 2015$  K. Symbols provide a code to the equivalence ratio.

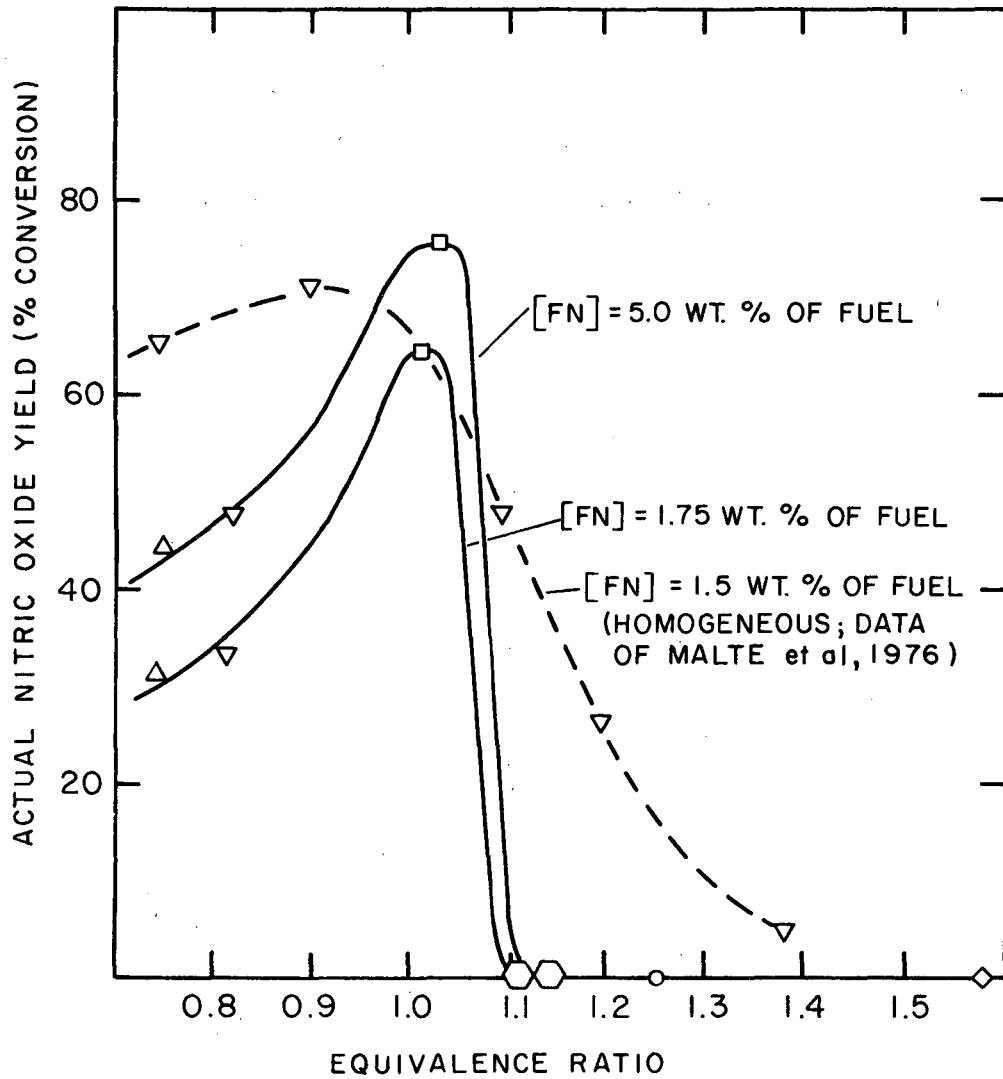

Figure 8-5. Comparison of the Relationship of Equivalence Ratio and NO yields Between Catalytic Combustion (solid curves) and Homogeneous Reaction (dashed curves). Ammonia addition.

the plot of NO yield versus equivalence ratio. The data for this graph were obtained with  $\text{NH}_3$  addition at fuel nitrogen fractions of 5.0 wt. % and 1.75 wt. %.

In Figures 8-4 and 8-5, it is seen that the NO yield increases and reaches a maximum at about  $\phi = 1$  and then drops to zero very rapidly. Decreasing the fuel nitrogen concentration from 5% to 1.75% decreases the NO yield by approximately 10% for stoichiometric and fuel lean catalytic combustion. Because there is no NO produced for either fuel-N concentration, the effect of [FN] is insignificant for fuel rich catalytic combustion. The data obtained by Malte et al. (1976) for  $\text{NH}_3$  addition to premixed  $\text{C}_3\text{H}_8/\text{air}$  combustion in a jet stirred reactor are also presented in Figure 8-5. The results of Axworthy and Schuman (1973) for  $\text{NH}_3$  addition to premixed  $\text{CH}_4/\text{O}_2/\text{Ar}$  flat flames are in excellent agreement with Malte's JSR data. A comparison of the trends for catalytic combustion and homogeneous combustion (Malte's data) reveals that the NO yields for catalytic combustion are much lower except near stoichiometric. The decrease in NO yield for  $\phi > 1$  is much more abrupt with catalytic combustion than with gas phase combustion. The NO yield in fuel lean catalytic combustion is significantly lower than for gas phase reaction. (Recall that if the catalytic combustor did not have the platinum coating, it would resemble the uncooled ceramic flat flame burner).

The effect of fuel nitrogen fraction on the conversion of  $\text{NH}_3$  to NO is presented in Figure 8-6. In the lean and stoichiometric cases, the NO yield increases with increasing fuel nitrogen concentration. For fuel rich catalytic combustion, the yield is independent of

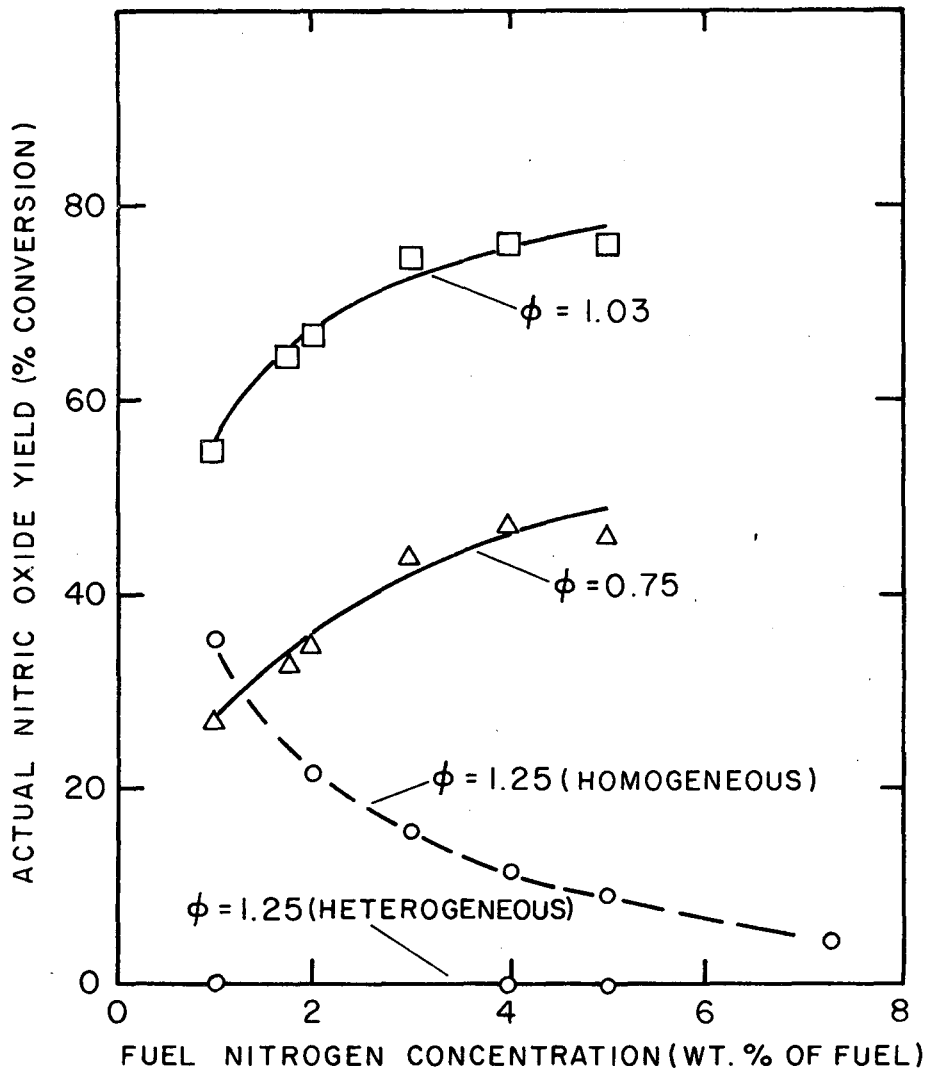

Figure 8-6. Effect of Fuel Nitrogen Concentration on the Conversion of  $\text{NH}_3$  to  $\text{NO}$  at Constant Equivalence Ratio and Adiabatic Flame Temperature. In the fuel rich case, the flat flame burner data are compared with the catalytic combustor data.

[FN] and equals zero. This is in striking contrast to the results of gas phase combustion, as depicted by the dashed curve of Figure 8-6. It has been well established that for both premixed and diffusion flames the NO yield decreases with increasing [FN]. Exactly the opposite trend is exhibited by catalytic combustors. The conclusion which may be drawn from the characteristics shown in Figures 8-4, 8-5, and 8-6 is that the fuel nitrogen conversion mechanism is dominated by surface reactions for catalytic combustion, at least for the conditions:  $P = 1$  atm,  $T_{in} = 298$  K, and  $v_{in} = 0.05$  m/sec.

Figure 8-7 shows that under near stoichiometric ( $\phi = 1.03$ ) conditions, the NO yield is relatively independent of the adiabatic flame temperature. This is shown as a function of fuel nitrogen concentration for  $NH_3$  addition at 5% and 1.75% by weight of the total fuel. Figure 8-8 demonstrates this same independence for rich ( $\phi = 1.23$ ), lean ( $\phi = 0.73$ ), and stoichiometric ( $\phi = 1.03$ ) conditions. The [FN] was 1.75% and the model fuel nitrogen compound was  $NH_3$ . Data from the flat flame burner experiments are also presented for comparison. The gas phase combustion results are shown with the dashed curve and are for  $\phi = 1.23$  and  $NH_3$  addition at a rate which yielded [FN] = 5.0%. In all cases a change in flame temperature of about 15% changed the NO yield by less than 5%. The combination of the following facts indicate the fuel-N conversion mechanism is influenced by surface reactions independent of the adiabatic flame temperature: 1) the major effect of increased inlet temperature is an increase in the adiabatic flame temperature and 2) the NO yield is relatively independent of flame temperature in both gas phase and catalytic combustion.

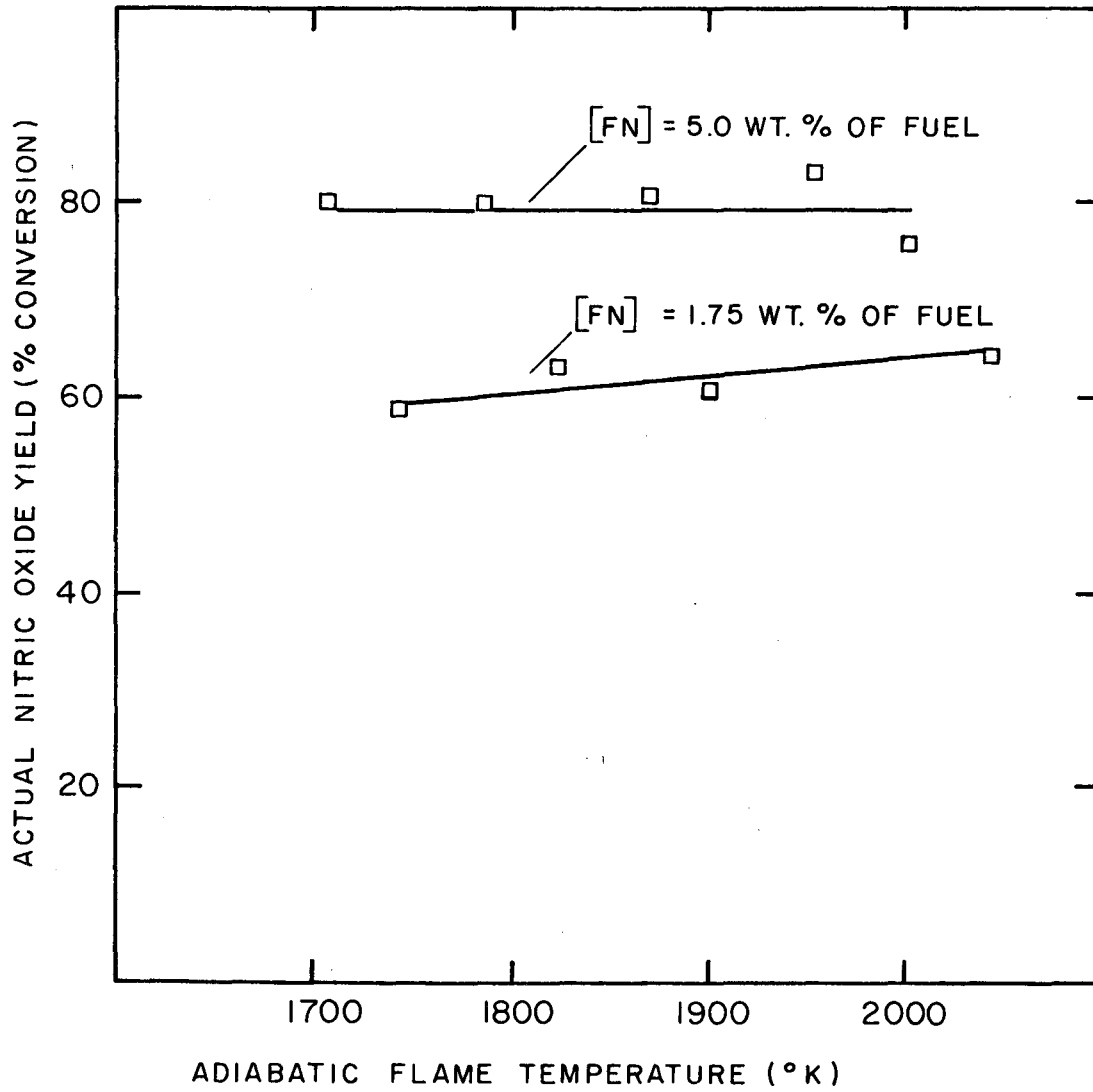

Figure 8-7. Effect of the Adiabatic Flame Temperature on the Conversion of  $\text{NH}_3$  to  $\text{NO}$  for Two Fuel-N Concentrations at  $\phi = 1.25$ , Catalytic Combustion.

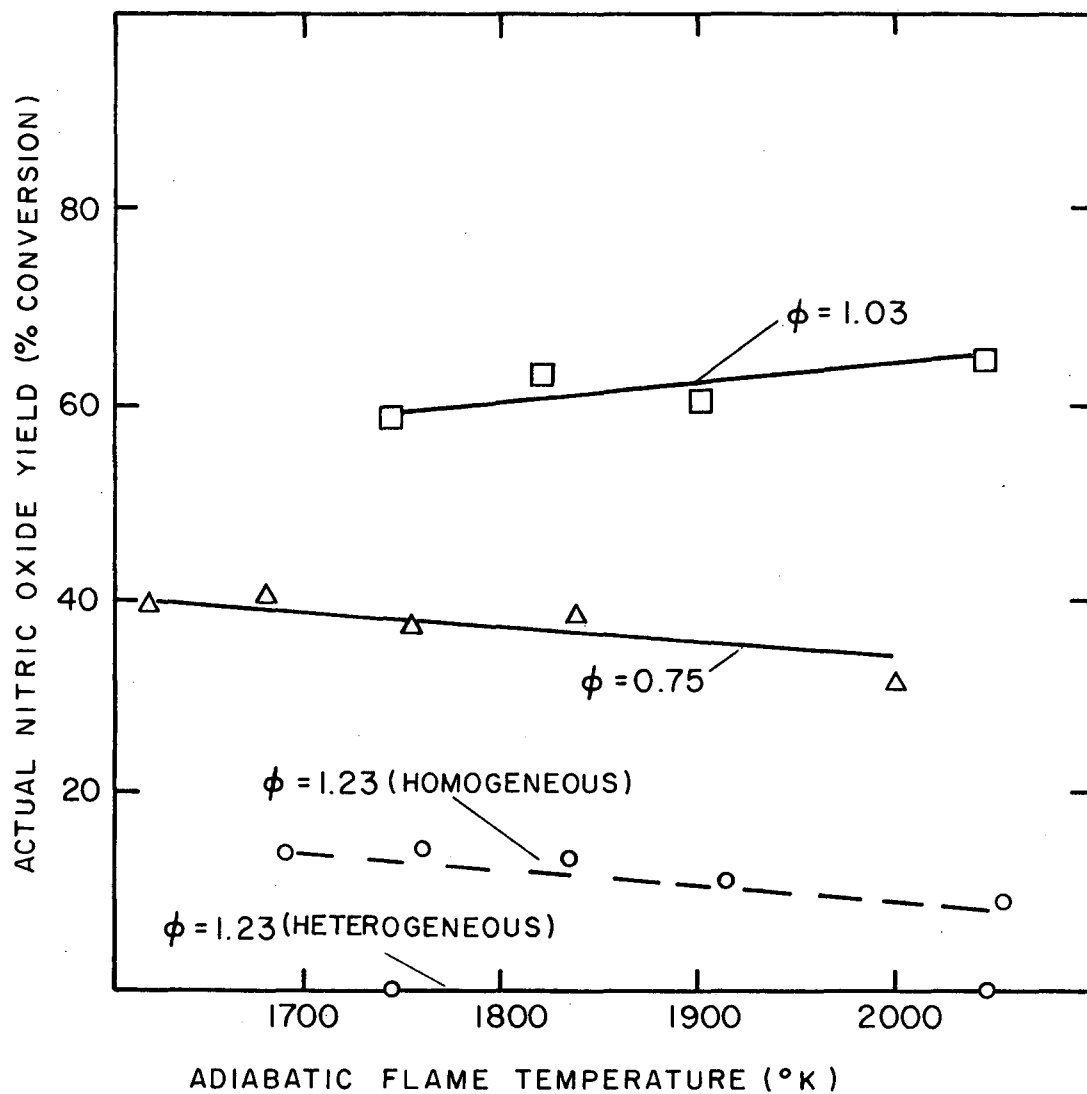

Figure 8-8. Effect of the Adiabatic Flame Temperature on the Conversion of  $\text{NH}_3$  to  $\text{NO}$  for Lean, Stoichiometric and Rich Catalytic Combustion.

The GC-CLA system revealed the presence of  $\text{NO}_x$ ,  $\text{NH}_3$ , and other unspecified N-species in the exhaust. One of these unidentified species may have been  $\text{N}_2\text{O}$  in the fuel lean case. The  $\text{NH}_3$  yield was qualitatively determined to be higher than for the flat flame burner under fuel rich conditions. Furthermore, tentative  $\text{NH}_3$  measurements indicated the yield to be relatively independent of equivalence ratio. In the fuel lean and stoichiometric cases a large peak was detected which did not match the expected elution times for  $\text{N}_2\text{O}$ , methyl cyanide, vinyl cyanide, or the nitroparaffins. This peak might be attributable to an amine because of its tailing characteristic. The colorimetric technique also indicated that  $\text{NH}_3$  was emitted from the catalytic combustor in much higher concentrations than from the flat flame burner. HCN was also identified. Vinyl cyanide and  $\text{NO}_2$  were not detected.

## 8.2 Discussion and Summary

A number of trends are observed when operating the catalytic combustor at atmospheric pressure, ambient inlet temperature, and an inlet velocity of 0.05 m/sec.

The measured temperatures in the catalytic combustor are significantly lower than the corresponding adiabatic flame temperatures. For fuel rich catalytic combustion,  $\text{CO}_2$  levels are significantly higher and CO emissions are much lower than equilibrium predictions. This results in the calculated combustion efficiency being higher than for equilibrium products for fuel rich operation.

The conversion of fuel nitrogen to NO is found to be strongly dependent on equivalence ratio, weakly dependent on calculated adiabatic

flame temperature, and moderately dependent on fuel nitrogen concentration. The NO yield increases with increasing equivalence ratio and reaches a maximum at about  $\phi = 1$ . It then drops to zero very rapidly. The NO yield is much lower for catalytic combustion than for gas phase combustion for all equivalence ratios except near stoichiometric. The NO yield increases with increasing fuel nitrogen fraction for lean and stoichiometric catalytic combustion and equals zero for rich catalytic combustion. This contrasts sharply with the behavior reported for homogeneous combustion systems, in which case the NO yield decreased with increasing fuel nitrogen fraction for lean, stoichiometric, and rich flames. Another contrast between catalytic and homogeneous combustion involves the relative conversion efficiencies of  $\text{NH}_3$  and NO in the fuel to NO in the products. In homogeneous combustion systems,  $\text{NH}_3$  is converted less efficiently, and in catalytic combustion systems it is converted more efficiently than is NO. This may be partially attributable to the nature of each species,  $\text{NH}_3$  being a fuel while NO is an oxidant. These contrasts indicate that the fuel nitrogen conversion mechanism may be dominated by surface reactions during catalytic combustion.

The evidence gathered in this investigation indicates that staged catalytic combustion might be preferable to homogeneous staged combustion or stoichiometric catalytic combustion. Fuel-NO yields should be much lower and overall combustion efficiencies should be higher in a staged catalytic combustion device than in a gas phase staged combustion system. Stoichiometric catalytic combustion appears to have no advantages over stoichiometric homogeneous combustion from the fuel-nitrogen and combustion efficiency perspectives. The NO

yield is relatively independent of the adiabatic flame temperature in both gas phase and catalytic combustion.

$\text{NH}_3$ , HCN,  $\text{NO}_x$ , and other unidentified nitrogenous species were noted in the catalytic combustion products.

Further research is necessary to determine the effect of pressure, inlet temperature, model fuel nitrogen compound, and especially inlet velocity on the fuel nitrogen conversion mechanism. Future investigations should also attempt to quantify emissions of nitrogenous species other than NO, especially  $\text{N}_2$ .

## CHAPTER 9

Summary and Conclusions

There have been three principal topics of this thesis: emission of nitrogenous species from combustion systems, fuel nitrogen, and catalytic combustion. The following paragraphs will be devoted to summarizing the information presented in this thesis and drawing conclusions based on this information.

Combustion sources account for more than 95% of the nationwide emissions of NO. It has recently been shown that a wide variety of other nitrogenous species are also emitted from combustion systems. This is a cause for concern because molecular nitrogen is the only clearly innocuous N-species. Other members of the family of gas phase nitrogenous species are odorants or lacrymators at low concentrations, affect visibility, play a role in the formation of photochemical smog, take part in atmospheric reactions which threaten the ozone layer, are capable of shifting the energy balance of the earth, are toxic at low levels, are precursors of carcinogens, or are directly carcinogenic. The most important N-species from the public health and air pollution perspectives are probably NO, NO<sub>2</sub>, N<sub>2</sub>O, HCN, NH<sub>3</sub>, and nitrosamines. In addition, the alkylamines, nitrates, and nitro-olefins may also be significant air pollutants. This evaluation is based not only on toxicological data and atmospheric chemistry, but also on estimated magnitude of sources.

Combustion generated N-species may be derived either from thermal fixation of  $N_2$  or from the use of fuels containing high concentrations of bound nitrogen. Several general conclusions may be drawn from the fuel nitrogen investigations which have been carried out to date.

Bowman (1976) summarizes these as:

- 1) Oxidation of many nitrogen-containing compounds is rapid, occurring on a time scale comparable to that of the combustion reactions.
- 2) In the vicinity of the combustion zone, observed NO concentrations significantly exceed calculated equilibrium values.
- 3) In the post combustion zone, the NO concentration decreases, relatively slowly for fuel-lean mixtures and more rapidly for fuel-rich mixtures.
- 4) The NO yield is particularly sensitive to the fuel/air equivalence ratio. Relatively high yields are obtained for lean and stoichiometric mixtures; relatively low yields are found for rich mixtures.
- 5) NO yields are only slightly dependent on temperature, contrasting with the strong temperature dependence of NO formation from molecular nitrogen.

The following conclusions may be added to Bowman's summary:

- 6) Pyrolysis of fuels containing bound nitrogen and typical fuel nitrogen compounds generally produces low molecular weight nitrogenous species such as HCN,  $NH_3$ , NO, and  $N_2$ .
- 7) The NO yield decreases with increasing fuel nitrogen concentration.
- 8) Decay of HCN, formation of  $NH_i$  species, and reactions governing

NO concentrations in the post flame zone are very sensitive to temperature. With decreasing temperature, HCN decays more slowly,  $\text{NH}_3$  builds up to higher concentrations and is more stable, and NO disappears more rapidly.

- 9) The formation of HCN,  $\text{NH}_3$ , and other nitrogenous species (e.g.,  $\text{CH}_3\text{CN}$  and  $\text{CH}_2\text{CHCN}$ ) is promoted with increasing equivalence ratios.
- 10) The yield of NO may be decreased and the yield of HCN (and, presumably, other N-species) may be increased in turbulent diffusion flames as compared to premixed combustion systems.
- 11) The NO yield is sensitive to mixing intensity and, in practical combustion systems, may also be a function of residence time and temperature history.

The sources of nitrogenous emissions which are not associated with the fuel nitrogen problem may be generally categorized as previously unrecognized sources, new sources resulting from efforts to reduce air pollution, and noncombustion sources.

It was not recognized until relatively recently that nitrogenous species other than NO and  $\text{N}_2$  could be emitted from spark ignition engines, compression ignition engines, gas turbines, power plants, or other combustion systems. The most important of these systems are probably automobiles and boilers. The species which may be emitted in the highest concentrations from spark-ignition engines are HCN and  $\text{NH}_3$ . The most important previously unsuspected N-species emitted from power plants may be  $\text{N}_2\text{O}$ . Other boilers may also emit cyanides and amines, especially HCN and  $\text{NH}_3$ . The principal factors governing emissions of these N-species seem to be: mixing intensity, residence time, and temperature history. It has been shown that odd N-species

may be emitted even from very fuel lean turbulent diffusion flames. The potential for emitting these compounds increases with increasing equivalence ratio. Fuel lean combustion appears to promote emission of  $\text{NO}_2$ .

Many air pollution control strategies which are directed at satisfying  $\text{NO}_x$  emissions regulations may inadvertently promote the emission of other objectionable N-species. Automotive exhaust purification catalysts have been shown to both produce and destroy HCN, depending on the operating conditions. The major pollutant N-species which are formed by these catalysts may be  $\text{NH}_3$  and  $\text{N}_2\text{O}$ . These two species may also be emitted in significant quantities from gas phase  $\text{NO}_x$  removal processes as applied to boilers. Fuel lean combustion systems, while decreasing total  $\text{NO}_x$  emissions, may promote the emission of  $\text{NO}_2$  in significant concentrations. It appears that very fuel lean systems which are not using fuels containing bound nitrogen are the only combustion systems that are immune from emitting objectionable N-species other than NO.

As the switch to fuels containing bound nitrogen progresses,  $\text{NO}_x$  emissions from stationary sources will increase. Current air pollution control technology may inadvertently promote the production of HCN,  $\text{N}_2\text{O}$ ,  $\text{NH}_3$ , or other nitrogenous species. It would be advisable to monitor emissions of these species from any device which is directed toward reducing the NO yield from fuel nitrogen because it is possible that the NO is reduced at the expense of increased emissions of these unwanted nitrogenous compounds.

Emissions of NO due to combustion of fuels containing organically bound nitrogen is a significant air pollution problem and will become

even more important in the near future. All but two of the traditional methods for controlling NO from thermal fixation either increase fuel NO or have no effect. These two are staged combustion and catalytic combustion. They also fall into the category of air pollution control strategies which share overall lean combustion as a common characteristic. It has been shown that staged combustion can decrease emissions of thermal NO and fuel NO but it has also been found that significant levels of HCN and  $\text{NH}_3$  (and presumably other N-species) are formed in the fuel rich primary stage. The extent of conversion of these species to NO and  $\text{N}_2$  at the exit from the combustion device is not clear. Catalytic combustion does not appear to emit significant quantities of N-species under lean operating conditions in the absence of fuel nitrogen. However, very little research has been aimed at investigating nitrogenous emissions in the presence of fuel-N, especially under near-stoichiometric and fuel rich conditions. This last case is of utmost interest because commercial and industrial boilers are the systems which are most likely to utilize the fuels which contain bound nitrogen and system thermal efficiency considerations dictate that they operate near stoichiometric.

This project investigates the emissions of N-species, especially NO and  $\text{N}_2$ , from catalytic combustors in the presence of fuel nitrogen. Equivalence ratios studied vary from lean (0.72) to rich (1.58) and include stoichiometric (1.0). For direct comparison with fuel rich catalytic combustion, the same species are monitored in the exhaust of a flat flame burner operating under the same conditions. This comparison allows some estimation of the extent to which heterogeneous reactions are controlling the conversion of fuel nitrogen.

The flat flame burner study of fuel nitrogen conversion was important because it confirmed and quantified characteristics reported by previous researchers. The experiments were carried out by adding NO or NH<sub>3</sub> to fuel rich C<sub>3</sub>H<sub>8</sub>/O<sub>2</sub>/Ar flat flames supported on an uncooled ceramic burner. Profiles of the fraction converted to NO (the NO yield) versus height above the burner were obtained for various adiabatic flame temperatures and fuel nitrogen concentrations. This resulted in the determination of a position where the reactions of importance to fuel nitrogen conversion were complete. The effect of fuel nitrogen concentration and adiabatic flame temperature on the NO yield is graphically displayed for both additives. The fraction of the additive converted to NO decreases with increasing fuel nitrogen concentration and is relatively independent of flame temperature. The NO yield is smaller when NH<sub>3</sub> is the model fuel nitrogen compound than when NO is the fuel-N species. Vinyl cyanide, HCN, NO<sub>x</sub>, and NH<sub>3</sub> were identified in the products. Other N-species were also detected but not identified. The data obtained when using this homogeneous combustion system are of particular interest when compared to the results obtained using the catalytic combustor.

A number of trends are observed when operating the catalytic combustor at atmospheric pressure, ambient inlet temperature, and an inlet velocity of 0.05 m/sec.

The measured temperatures in the catalytic combustor are significantly lower than the corresponding adiabatic flame temperatures. For fuel rich catalytic combustion, CO<sub>2</sub> levels are significantly higher and CO emissions are much lower than equilibrium predictions.

This results in the calculated combustion efficiency being higher than for equilibrium products for fuel rich operation.

The conversion of fuel nitrogen to NO is found to be strongly dependent on equivalence ratio, weakly dependent on calculated adiabatic flame temperature, and moderately dependent on fuel nitrogen concentration. The NO yield increases with increasing equivalence ratio and reaches a maximum at about  $\phi = 1$ . It then drops to zero very rapidly. The NO yield is much lower for catalytic combustion than for gas phase combustion for all equivalence ratios except near stoichiometric. The NO yield increases with increasing fuel nitrogen fraction for lean and stoichiometric catalytic combustion and equals zero for rich catalytic combustion. This contrasts sharply with the behavior reported for homogeneous combustion systems, in which case the NO yield decreased with increasing fuel nitrogen fraction for lean, stoichiometric, and rich flames.

Another contrast between catalytic and homogeneous combustion involves the relative conversion efficiencies of  $\text{NH}_3$  and NO in the fuel to NO in the products. In homogeneous combustion systems  $\text{NH}_3$  is converted less efficiently than is NO. This may be partially attributable to the nature of each species,  $\text{NH}_3$  being a fuel while NO is an oxidant. These contrasts indicate that the fuel nitrogen conversion mechanism may be dominated by surface reactions during catalytic combustion. The evidence gathered in this investigation indicates that staged catalytic combustion might be preferable to homogeneous staged combustion or stoichiometric catalytic combustion. Fuel-NO yields should be much lower and overall combustion efficiencies should be higher in

a staged catalytic combustion device than in a gas phase staged combustion system. Stoichiometric catalytic combustion appears to have no advantages over stoichiometric homogeneous combustion from the fuel-nitrogen and combustion efficiency perspectives. The NO yield is relatively independent of the adiabatic flame temperature in both gas phase and catalytic combustion.

NH<sub>3</sub>, HCN, NO<sub>x</sub>, and other unidentified nitrogenous species were noted in the catalytic combustion products.

Further research is necessary to determine the effect of pressure, inlet temperature, model fuel nitrogen compound, and especially inlet velocity on the fuel nitrogen conversion mechanism. Future investigations should also attempt to quantify emissions of nitrogenous species other than NO, especially N<sub>2</sub>.

REFERENCES

- Adelman, H.G., Andrews, D.G. and Devoto, R.S. (1972). Exhaust emissions from an ethanol fueled automobile. SAE Paper No. 720693.
- Airesearch (1971). Exhaust emissions test: Airesearch aircraft propulsion and auxiliary power gas engines. Report No. GT-8747-R, 10 September.
- Albert, R.E., Berger, J., Sanborn, K. and Lippmann, M. (1974). Effects of cigarette smoke components on bronchial clearance in the donkey. Arch. Environ. Health, 29, 96-101.
- Allen, J.D. (1975). Probe sampling of oxides of nitrogen from flames. Combustion and Flame, 24, 133-136.
- Amin, H. (1977). Effect of heterogeneous removal of oxygen atoms on measurement of nitrogen dioxide in combustion gas sampling probes. Combustion Science and Technology, 15, 31-40.
- Anderson, D.N. (1977). Emissions and performance of catalysts for gas turbine catalytic combustors. ASME Report No. 77-GT-65.
- Anderson, D.N., Tacina, R.R. and Mroz, T.S. (1975). Performance of a catalytic reactor at simulated gas turbine combustor operating conditions. NASA Technical Memorandum, NASA TM-71747.
- Angeli, J.W. (1977). Design and testing of a heat recirculation combustor for a gas turbine. MS Thesis, Department of Mechanical Engineering, University of California, Berkeley.
- Appleton, J.P. and Heywood, J.B. (1973). The effects of imperfect fuel-air mixing in a burner on NO formation from nitrogen in the air and the fuel. Fourteenth Symposium (International) on Combustion, 777.
- Austin, A.L. and Sawyer, R.F. (1973). The hydrogen fuel economy and aircraft propulsion. AIAA Paper No. 73-1319.
- Axworthy, A.E. and Schuman, M. (1973). Investigation of the mechanism and chemistry of fuel nitrogen conversion to nitrogen oxides in combustion. Presented at the Coal Combustion Symposium, Environmental Protection Agency, Research Triangle Park, North Carolina.
- Axworthy, A.E. (1975). Flat flame burner studies with HCN, NH<sub>3</sub>, and NO addition. Presented at the June EPA Contractors Meeting.

- Axworthy, A.E., Schneider, G.R. and Dayan, V.H. (1975). Chemical reactions in the conversion of fuel nitrogen to  $\text{NO}_x$ , EPA Conference, Atlanta, Georgia.
- Axworthy, A.E. and Dayan, V.H. (1977). Chemical reactions in the conversion of fuel nitrogen to  $\text{NO}_x$ : Fuel pyrolysis studies. 2nd Stationary Source Combustion Symposium, New Orleans, August.
- Azelborn, N.A., Wade, W.R., Secord, J.R. and McLean, A.F. (1973). Low emissions combustion for the regenerative gas turbine. Part 2: experimental techniques, results, and assessment. ASME Paper No. 73-GT-12.
- Bachmaier, F., Eberius, K.H. and Just, Th. (1973). The formation of nitric oxide and the detection of HCN in premixed hydrocarbon-air flames at 1 atmosphere. Combustion Science and Technology, 7, 77-84.
- Balakhnine, V.P., Vandooren, J. and Van Tiggelen, P.J. (1977). Reaction mechanism and rate constants in lean hydrogen-nitrous oxide flames. Combustion and Flame, 28, 165-173.
- Ball, J.S. and Roll, H.T. (1962). Nonhydrocarbon components of a California petroleum. Presented at the 27th Midyear Meeting of the API Refinery Division, San Francisco, California.
- Barnes, J.M. and Magee, P.N. (1954). Some toxic properties of dimethylnitrosamine. Brit. J. Indust. Med., 11, 167.
- Barnes, G.J. and Summers, J.C. (1975). Hydrogen sulfide formation over automotive oxidation catalysts. SAE Paper No. 750093, Automotive Engineering Congress. Detroit Michigan.
- Barnhart, D.A. and Diehl, E.K. (1960). Control of nitrogen oxides in boiler flue gases by two-stage combustion. J. APCA, 10, 5, 397-405.
- Bartok, W., Engleman, V.S., Goldstein, R. and Del Valle, E.G. (1971). Basic kinetic studies and modeling of nitric oxide formation in combustion processes. AICHE Symposium Series, 68, 126, 30-38.
- Battigelli, M.C. (1971). Biological significance of nitrogen oxides. SAE Paper No. 710298 in Medical Aspects of Air Pollution, Society of Automotive Engineers, New York.
- Bellar, T.A. and Sigsby, J.E. (1970). Direct gas chromatographic analysis of low molecular weight substituted organic compounds in emissions. Environmental Science and Technology, 4, 2, 150-156.
- Benson, R., Samuelson, G.S. and Peck, R.E. (1976). Oxides of nitrogen transformation while sampling combustion products containing carbon monoxide. Presented at the Spring Meeting of the WSS/CI, Salt Lake City, Utah.

- Berkowitz, B.A., Ngai, S.H. and Finck, A.D. (1976). Nitrous oxide "analgesia": resemblance to opiate action. Science, 194, 967-968.
- Blair, D.W., Wendt, J.O.L. and Bartok, W. (1977). Evolution of nitrogen and other species during controlled pyrolysis of coal. Sixteenth Symposium (International) on Combustion, The Combustion Institute, Pittsburgh, 475.
- Blakeslee, C.F. and Burbach, H.E. (1973). Controlling NO<sub>x</sub> emissions from steam generators. Journal of the Air Pollution Control Association, 23, 1.
- Blauwens, J., Smets, B. and Peeters, J. (1977). Mechanism of "prompt" nitric oxide formation on hydrocarbon flames. Sixteenth Symposium (International) on Combustion, The Combustion Institute, Pittsburgh, 1055.
- Blazowski, W.S. and Sawyer, R.F. (1975). Fundamentals of pollutant formation, Chapter 3 of CIAP Monograph 2, Propulsion Effluents in the Stratosphere. Report No. DOT-TST-75-52.
- Blazowski, W.D. and Walsh, D.E. (1975). Catalytic combustion: an important consideration for future applications. Combustion Science and Technology, 10, 233-244.
- Bogovski, P. (1973). Use of environmental carcinogens. Chapter 2 in Annual Report 1972-1973. International Agency for Research on Cancer. World Health Organization, Lyon, France.
- Bogovski, P., Castegnaro, M., Pignatelli, B. and Walker, E.A. (1972). The inhibiting effect of tannins on the formation of nitrosamines. In N-Nitroso Compounds: Analysis and Formation, Bogovski, Preussman, and Walker, Editors. IARC Scientific Publication No. 3, Lyon, France.
- Boren, H.G. (1964). Carbon as a carrier mechanism for irritant gases. Arch. Env. Health, 8, 119.
- Bowman, C.T. (1973). Kinetics of nitric oxide formation in combustion processes. Fourteenth Symposium (International) on Combustion, 729, The Combustion Institute, Pittsburgh.
- Bowman, C.T. (1976). Kinetics of pollutant formation and destruction in combustion. Prog. Energy Combust. Sci., 1, 33.
- Boyd, E.M., MacLachlan, M.L. and Perry, W.F. (1944). Experimental ammonia gas poisoning in rabbits and cats. J. Ind. Hyg. and Tox., 26, 1, 29-34.
- Boyland, E. and Walker, S.A. (1974). Catalysis of the reaction of aminopyrine and nitrite by thiocyanate. Argneimittel-Forsch., 24, 1181-1184.

- Braddock, J.N. and Bradow, R.L. (1975). Emissions patterns of diesel-powered passenger cars. SAE Paper No. 750682.
- Braddock, J.N. and Gabele, P.A. (1977). Emission patterns of diesel-powered passenger cars--Part II. SAE Paper No. 770168.
- Braker, W. and Mossman, A.L. (1971). Mattheson Gas Data Book, 5th Edition, Mattheson, Milwaukee, Wisconsin.
- Bretschneider, K. and Matz, J. (1973). Nitrosamines (NA) in the atmospheric air and in the air at the workplace. Archiv. fur Geschwulst-Forsch., 42, 36-41.
- Butts, W.C., Kuehneman, M. and Widdowson, G.M. (1974). Automated method for determining serum thiocyanate, to distinguish smokers from nonsmokers. Clin. Chem., 20, 1344-1348.
- Caretto, L.S. (1976). Mathematical modeling of pollutant formation. Prog. Energy Comb. Sci., 1, 47-71.
- Carotti, A.A. and Kaiser, E.R. (1972). Concentrations of twenty gaseous chemical species in the flue gas of a municipal incinerator. J. APCA, 22, 4, 248-253.
- Carpenter, C.P., Smyth, H.F. and Pozzani, U.C. (1949). The assay of acute vapor toxicity and the grading and interpretation of results on 96 chemical compounds. J. Ind. Hyg. and Tox., 31, 6, 343-346.
- Carson, T.R., Rosenholtz, M.S., Wilinski, F.T. and Weeks, M.H. (1962). The responses of animals inhaling nitrogen dioxide for single, short-term exposures. Am. Ind. Hyg. Assoc. J., 23, 457-462.
- Carter, R.L., Percival, W.H. and Roe, F.J.C. (1969). Exceptional sensitivity of mink to the hepatotoxic effects of dimethylnitrosamine. J. Path., 97, 79-88.
- Caton, J.A. (1976). Heterogeneous catalysis of lean ethylene/air mixtures by platinum coated wire screens. ASME Report No. 76-WA/GT-2.
- Cernansky, N.P. (1976). Sampling and measuring for NO and NO<sub>2</sub> in combustion systems. AIAA Paper No. 76-139, presented at the 14th Aerospace Sciences Meeting, Washington, D.C.
- Cernansky, N.P. and Sawyer, R.F. (1975). NO and NO<sub>2</sub> formation in a turbulent hydrocarbon/air diffusion flame. Fifteenth Symposium (International) on Combustion, The Combustion Institute, Pittsburgh, 1039-1050.
- Chenoweth, L.B. and Machle, W. (1938). Industrial Hygiene. Crofts, New York, NY, 110.

- Christensen, H.E., Luginbyhl, T.T., editors. (1975). Registry of Toxic Effects of Chemical Substances. U.S. Department of Health, Education, and Welfare Health Service, National Institute of Occupational Safety and Health.
- Cichanowicz, J.E. and Sawyer, R.F. (1976). Rotary engine combustion with hydrogen addition. Society of Automotive Engineers, Paper No. 760611.
- Climatic Impact Assessment Program (1975). Monograph I. Report DOT-TST-75-51, Department of Transportation, Washington, pp. 1-20.
- Conkles, J.P., Lackey, W.W., Martin, C.L. and Miller, R.L. (1976). Organic compounds in turbine combustor exhausts. International Conference on the Sensing of Environmental Pollutants, Las Vegas, Nevada, Paper No. 27-2.
- Coppersmith, F.M., Jastrozelski, R.F., Giovanni, D.V. and Hersh, S. (1974). Con Edison's gas turbine test program: A comprehensive evaluation of stationary gas turbine emission levels. APCA Paper No. 74-12.
- Craig, H., Weiss, R.F. and Dowd, W.L. (1976). Paper presented at the AGU Symposium on the Terrestrial Nitrogen Cycle and Possible Atmospheric Effects. Manuscript in preparation.
- Crutzen, P.J. (1970). Quart. J. Roy. Meteorol. Soc., 96, 320.
- Crutzen, P.J. (1971). Ozone production rates in an oxygen, hydrogen, nitrogen oxide atmosphere. J. Geophys. Res. 76, 7311.
- Cullis, C.F. and Smith, L.S.A. (1950). The thermal oxidation of the aliphatic amines. Transactions of the Faraday Society, 46, p. 42.
- Dahn, A., Loewe, L., and Bunton, C.A. (1960). Über die oxidation von Ascorbinsäure durch salpetrige Säure, VI. Übersicht und Diskussion der Ergebnisse. Helv. Chem. Acta, 43, 320.
- Dalhamn, T. (1956). Acta Physiol. Scand. 36, Suppl., 123, 1-161.
- De Corso, S.M., Mumford, S., Carrubba, R. and Heck, R. (1976). Catalysts for gas turbine combustors--experimental test results. ASME Paper No. 76-GT-4.
- Deichmann, W.B., MacDonald, W.E. and Anderson, W.A.D. (1963). Adenocarcinoma in the lungs of mice exposed to vapors of 3-nitro-3-hexene. Toxic Appl. Pharmacol. 5, 446.
- Deichmann, W.B., MacDonald, W.E. and Lampe, K.F. (1965). Nitro-olefins as potential carcinogens in air pollution. Indust. Med. Surg. 34, 800-807.

- De Soete, G.G. (1974). Overall reaction rates of NO and N<sub>2</sub> formation from fuel nitrogen. Fifteenth Symposium (International) on Combustion, The Combustion Institute, Pittsburgh, 1093.
- Dietzmann, H.E. (1975). Protocol to characterize gaseous emissions as a function of fuel-additive composition. EPA Report No. EPA-600/2-75-048.
- Documentation of the Threshold Limit Values. (1971). American Conference of Governmental Industrial Hygienists, Third Edition.
- Dongworth, M.R. and Melvin, A. (1977). Diffusive catalytic combustion. Sixteenth Symposium (International) on Combustion, The Combustion Institute, Pittsburgh, 255.
- Druckrey, H. Preussmann, R., Ivankovic, S. and Schmahl, D. (1967). Organotrope carcinogene Wirkungen bei 65 verschiedenen N-nitrosoverbindungen an BD-Ratten. Z. Krebsforsch. 69, 103-201.
- Druckrey, H., Preussmann, R., Ivankovic, S. Schmidt, C.H., Mennel, H.D. and Stahl, K.W. (1964). Selective induction of bladder cancer in rats with dibutyl and N-butyl-N-(4-hydroxybutyl)-nitrosamine. Z. Krebsforsch 66, 280-290.
- Dudley, H.C. and Neal, P.A. (1942). Toxicology of acrylonitrile (vinyl cyanide), I. J. Ind. Hyg. Toxicol. 24, 2, 27-36.
- Dudley, H.C., Sweeney, T.R. and Miller, J.W. (1942). Toxicology of acrylonitrile (vinyl cyanide) II. J. Ind. Hyg. and Toxicol. 24, 255-259.
- Duxbury, J. and Pratt, N.H. (1973). A shock tube investigation of the fuel nitrogen-nitric oxide problem. Combustion Institute European Symposium, Academic Press, 433-438.
- Duxbury, J. and Pratt, N.H. (1974). A shock tube study of NO kinetics in the presence of H<sub>2</sub> and fuel-N. Fifteenth Symposium (International) on Combustion, The Combustion Institute, Pittsburgh, 843.
- Eberius, K.H. (1972). in comments. Fourteenth Symposium (International) on Combustion. The Combustion Institute, Pittsburgh, 775.
- England, C. Houseman, J. and Texeira, D.P. (1973). Sampling nitric oxide from combustion gases. Combustion and Flame, 20, 439-442.
- EPA (1974). Summary report on atmospheric nitrates. U.S. Environmental Protection Agency, National Environmental Research Center, Research Triangle Park, North Carolina.
- EPA (1977). Scientific and technical assessment report on nitrosamines. U.S. Environmental Protection Agency, Report EPA-600/6-77-001.

- Exxon (1977). A way to lower  $\text{NO}_x$  in utility boilers. Environmental Science and Technology, 11, 3, 226-228.
- Fairhall, L.T. (1969). Industrial Toxicology. Hafner, New York.
- Federation of American Scientists (1976). Public Interest Report, 29, 5, 1.
- Fenimore, C.P. (1971). Formation of nitric oxide in premixed hydrocarbon flames. Thirteenth Symposium (International) on Combustion, The Combustion Institute, Pittsburgh, 373.
- Fenimore, C.P. (1972). Formation of nitric oxide from fuel nitrogen in ethylene flames. Combustion and Flame, 19, 289-296.
- Fenimore, C.P. (1976). Reactions of fuel-nitrogen in rich flame gases. Combustion and Flame, 26, 249-256.
- Fenimore, C.P. (1977). Effects of diluents and mixing on NO from fuel nitrogen in diffusion flames. Sixteenth Symposium (International) on Combustion, The Combustion Institute, Pittsburgh, 1065.
- Fine, D.H., Rounbehler, D.P., Belcher, N.M. and Epstein, S.S. (1976). N-nitroso compounds: detection in ambient air. Science, 192, 1328-1330.
- Fine, D.H., Ruffa, F., Lieb, D., and Epstein, S.S. (1974). A possible nitrogen oxide nitrosamine-cancer link. Bull. Environmental Contamination and Toxicol., 11, 1, 18-19.
- Fine, D.H., Slatter, S.M., Sarofim, A.F., Williams, G.C. (1971). The importance of nitrogen in coal as a source of NO. for presentation at AIChE 64th Annual Meeting, San Francisco, November 28- December 2.
- Flower, W.L., Hanson, R.K. and Kruger, C.H. (1975). Kinetics of the reaction of nitric oxide with hydrogen. Fifteenth Symposium (International) on Combustion, The Combustion Institute, Pittsburgh, 823.
- Flury, F., Zernik, F. (1931). Schadliche Gase, Springer, Berlin.
- Freeman, G. Crane, S.S. and Furiosi, N.J. (1969a). Healing in rat lung after subacute exposure to nitrogen dioxide. Am. Rev. Resp. Dis., 100, 662-676.
- Freeman, G. Crane, S.C., Stephens, R.J. and Furiosi, N.J. (1969b). The subacute nitrogen dioxide-induced lesion of the rat lung. Arch. Env. Health, 20, 566.
- Freund, H.A. (1937). Clinical manifestations and studies in parenchymatous hepatitis. Ann. Int. Med., 10, 1144.

- Gabele, P.A., Braddock, J.N. and Bradow, R.L. (1977). A characterization of exhaust emissions from lean-burn, rotary, and stratified charge engines. Society of Automotive Engineers, Paper No. 770301.
- Ganji, A., Branch, M.C. and Oppenheim, A.K. (1976). Design study of a gas turbine combustor with heat recirculation. AIAA Paper No. 76-611, AIAA/SAE 12th Propulsion Conference, Palo Alto, California.
- Ganji, A.J., Short, J., Branch, M.C. and Oppenheim, A.K. (1976). Gas turbine combustor stabilization by heat recirculation. AIAA Journal 14, 6, 809-812.
- Gaskill, J.R. (1970). Smoke development in polymers during pyrolysis or combustion. Journal of Fire and Flammability, 1, 183.
- Gaynor, J., editor (1976). Monthly Energy Review. Federal Energy Administration. NTISUB/B/127-76/011, November.
- Gibbs, B.M., Pereira, F.J. and Beér, J.M. (1977). The influence of air staging on the NO emissions from a fluidized-bed coal combustor. The Sixteenth Symposium (International) on Combustion, The Combustion Institute, Pittsburgh, 461-474.
- Gibson, Q.H. and Roughton, F.J.W. (1957). The kinetics and equilibria of the reactions of nitric oxide with sheep haemoglobin. J. Physiol. 136, 507.
- Gleason, M.N., Gosselin, R.E. and Hodge, H.C. (1963). Clinical Toxicology of Commercial Products, Williams and Wilkins, Baltimore, pp. 54-56.
- Grabois, B. (1955). Monthly Review, Division of Industrial Hygiene, New York State Department of Labor, 34, 1.
- Gray, E. LeB. (1959). Oxides of nitrogen: their occurrence, toxicity, hazard; brief review. Arch. Ind. Health, 19, 479.
- Gray, E. LeB., Goldberg, S.B. and Patton, F.M. (1954). Toxicity of the oxides of nitrogen, III. AMA Arch. Ind. Hyg. 10, 423-425.
- Gray, E. LeB., McNamee, J.K. and Goldberg, S.B. (1952). Toxicity of NO<sub>2</sub> vapors at very low levels. AMA Arch. Ind. Hyg. 6, 20.
- Gray, E. LeB., Patton, F.M., Goldberg, S.B. and Kaplan, E. (1954). Toxicity of the oxides of nitrogen, II. AMA Arch. Ind. Hyg. 10, 418-422.
- Grobecker, A.J., Coroniti, S.C. and Cannon, R.H. (1974). The effects of stratospheric pollution by aircraft. Final Report, Climatic Impact Assessment Program, U.S. Department of Transportation, DOT-TST-75-50.

- Gross, D. Loftus, J.J., Lee, T.G., Gray, V.E. (1969). Smoke and gases produced by burning aircraft interior materials. NBS Building Science Series 18.
- Hackney, D., Linn, W.S., Mohler, J.G., Pederson, E., Breisacher, P. and Russo, A. (1975). Experimental studies on human health effects of air pollutants. Arch. Environ. Health, 30, 379-390.
- Hahn, J. (1974). The north Atlantic Ocean as a source of atmospheric N<sub>2</sub>O, Tellus, 26, 160-168.
- Hahn, J. (1975). N<sub>2</sub>O measurements in the northeast Atlantic Ocean, Meteor Forsch. Ergebnisse A, 16, 1-14.
- Hamilton, A. and Hardy, H.L. (1974). Industrial Toxicology, Publishing Sciences Group, Acton, Massachusetts, Chapter 5.
- Handy, R. and Schindler, A. (1976). Estimation of permissible concentrations of pollutants for continuous exposure. Prepared for the EPA. NTIS Publication PB-253-959.
- Hanst, P.L., Spence, J.W. and Miller, M.F. (1976). Atmospheric chemistry of N-nitroso dimethylamine. Presented before the Division of Environmental Chemistry, American Chemical Society, New York.
- Hardesty, D.R. and Weinberg, F.J. (1974). Burners producing large excess enthalpies. Combustion Science and Technology, 8, 201-214.
- Hardy, H.L., Jeffries, W.McK., Wasserman, M.M. and Waddell, W.R. (1950). Thiocyanate effect following industrial cyanide exposure. New Engl. J. Medicine, 24, 968-972.
- Harkins, J.H. and Nicksic, S.W. (1967). Ammonia in auto exhaust, Environmental Science and Technology, 1, 749-750.
- Haynes, B.S. (1975). The formation and behavior of nitrogen species in fuel rich hydrocarbon flames, Ph.D. Thesis, University of New South Wales.
- Haynes, B.S. (1977a). Reactions of ammonia and nitric oxide in the burnt gases of fuel-rich hydrocarbon-air flames. Combustion and Flame 28, 81-91.
- Haynes, B.S. (1977b). The oxidation of hydrogen cyanide in fuel-rich flames, Combustion and Flame, 28, 113-121.
- Haynes, B.S., Iverach, D. and Kirov, N.Y. (1975). The behavior of nitrogen species in fuel rich hydrocarbon flames. Fifteenth Symposium (International) on Combustion, The Combustion Institute, Pittsburgh, 1103.

- Haynes, B.S. and Kirov, N.Y. (1974). Nitric oxide formation during the combustion of coal. Combustion and Flame, 23, 277.
- Heap, M.P., Tyson, T.J., Cichanowicz, J.E., Gershman, R., Kau, J., Martin, G.B., Lanier, W.S. (1977). Environmental aspects of low BTU gas combustion. Sixteenth Symposium (International) on Combustion, The Combustion Institute, Pittsburgh, 535.
- Henderson, Y. and Haggard, H.W. (1943). Noxious Gases. Reinhold, New York, pp. 172-175.
- Henry, M.C., Ehrlich, R. and Blair, W.H. (1969). Effect of nitrogen dioxide on resistance of squirrel monkeys to Klebsiella Pnuemoniae infection. Arch. Env. Health, 18, 580.
- Heywood, J.B., Fay, J.A. and Linden, L.H. (1971). Jet aircraft air pollutant production and dispersion. AIAA J., 9, 5, 841-850.
- Hickey, R.J., Boyce, De. E., Harner, E.B. and Clelland, R.C. (1970). Ecological statistical studies on environmental pollution and chronic disease in metropolitan areas of the United States. RSRI Discussion Paper Series No. 35. Philadelphia Regional Science Research Institute.
- Hilliard, J.C. and Wheeler, R.W. (1977). Catalyzed oxidation of nitric oxide to nitrogen dioxide. Combustion and Flame, 29, 15-19.
- Hoehn, F.W. and Dowdy, M.W. (1974). Feasibility demonstration of a road vehicle with hydrogen-enriched fuel. Proceedings of the 9th Intersociety Energy Conversion Conference.
- Hoffmann, D. (1974). Comparative chemical analysis of Indian Bidi and American cigarette smoke. International Journal of Cancer, 14, 49-53.
- Houseman, J. and Cerini, D.J. (1974). On board hydrogen generator for a partial hydrogen injection internal combustion engine. SAE Paper No. 740600.
- Houseman, J. and Cerini, D.J. (1976). Two-stage combustion for low emissions without catalytic convertors. SAE Paper No. 760759.
- Houseman, J. and Hoehn, F.W. (1974). A two charge engine concept: hydrogen enrichment. SAE Paper No. 741169.
- Hurn, R.W., Allsup, J.R. and Cox, F.W. (1974). Effect of gasoline additives on gaseous emissions. EPA report no. EPA-650/2-75-014.
- Hurn, R.W., Cox, F.W. and Allsup, J.R. (1976). Effect of gasoline additives on gaseous emissions, part II. EPA report no. EPA-600/2-76-026.
- Industrial Hygiene Quarterly (1956). AIHA Journal, September, 347-349.

- Jacobs, M.B. (1960). The Chemical Analysis of Air Pollutants, Interscience, New York, pp. 413-415.
- Jacobson, K.H., Wheelwright, H.J., Clem, J.H., and Shannon, R.N. (1955). Studies on the toxicology of N-nitrosodimethylamine vapor. AMA Arch. Ind. Health, 12, 617-622.
- Jayanty, R.K.M., Simonaitis, R. and Heicklen, J. (1974). The inhibition of photochemical smog--III. Inhibition by diethylhydroxylamine, N-methylaniline, triethylamine, diethylamine, ethylamine, and ammonia. Atmos. Environ. 8, 1283-1289.
- Jet Propulsion Laboratory (1974). JPL Final Report on EPA-Supported Studies Related to Ultralean Combustion with Hydrogen Addition. JPL, Pasadena, California.
- Johnston, H.S. (1971). Reduction of stratospheric ozone by nitrogen oxide catalysts from supersonic transport exhaust. Science, 173, 517-522.
- Johnston, H.S. and Selwyn, G.S. (1975). New cross section for the absorption of near ultraviolet radiation by nitrous oxide. Geophys. Res. Letters, 2, 549-551.
- Jolley, C.J. (1934). The thermal oxidation of methylamine. Journal Chem. Soc., 1957-1966.
- Jones, J.F. (1966). Coal Oil Energy Development. Office of Coal Research, Contract No. 14-91-601-235. Washington, D.C.
- Kaneko, M. (1974). On cyanide in air. Air Pollution Abstracts, 5, 9, 22.
- Kant, V. (1970). Formation of nitrosamines (in lung tissue) after inhalation of nitrogen oxides. Cezk. Hyg., 1970, 213-215.
- Kaskan, W.E. and Hughes, D.E. (1973). Mechanism of decay of ammonia in flame gases from an NH<sub>3</sub>/O<sub>2</sub> flame. Combustion and Flame, 20, 381-388.
- Keefer, L.K. and Roller, P.P. (1973). N-nitrosation by nitrite ion in neutral and basic medium. Science, 181, 1245-1246.
- Kobert, R. (1912). Komp. des Prak. Toxicol. Stuttgart, p.45.
- Koshi, M., Ando, H., Oya, M. and Asaba, T. (1975). Shock tube study of decomposition of nitric oxide at high temperature. Fifteenth Symposium (International) on Combustion, The Combustion Institute, Pittsburgh, 809.
- Kramlich, J.C. (1976). Computer modeling of chemical kinetics in quartz gas sampling probes. Report for Department of Mechanical Engineering, Washington State University, Pullman, Washington.

- Lampe, K.F. and Deichmann, W.B. (1961). The identification of nitro-olefins in the combustion products of hydrocarbons. Indust. Med. Surg., 33, 281-283.
- Lampe, K.F. and Deichmann, W.B. (1965). The identification of nitro-olefins in the combustion products of hydrocarbons, II. Indust. Med. Surg., 34, 151.
- Lampe, K.F., Mende, T.J. and Deichmann, W.B. (1958). Evaluation of conjugated nitro-olefins as eye irritants in air pollution. Indust. Med. Surg., 27, 375-377.
- Lawton, A.H., Sweeney, T.R., and Dudley, H.C. (1943). Toxicology of acrylonitrile (vinyl cyanide), III. J. Ind. Hyg. Toxicol. 25, 13.
- Lee, C.H. and Makowski, M.P. (1974). Some aspects of the mechanism of NO<sub>x</sub> reduction over nickel alloy catalysts. SAE Paper No. 741080.
- Lefebvre, A.H. and Fletcher, R.S. (1973). A preliminary study on the influence of fuel staging on nitric oxide emission from gas turbine combustors. Atmospheric Pollution by Aircraft Engines, AGARD, CP No. R5.
- Leonard, P.A., Plee, S.L. and Mellor, A.M. (1976). Nitric oxide formation from fuel and atmospheric nitrogen. Combustion Science and Technology, 14, 183-193.
- Lestz, S.S. (1975). Analysis of combustion products from nitrogenous gasoline additives. Pennsylvania State University, Interim Report to the EPA.
- Lloyd, S.A. and Weinberg, F.J. (1974). A burner for mixtures of very low heat content. Nature, 251, 47-49.
- Lloyd, S.A. and Weinberg, F.J. (1975). Limits to energy release and utilization from chemical fuels. Nature, 257, 367-370.
- Lyon, R.K. (1976). The NH<sub>3</sub>-NO-O<sub>2</sub> reaction. International Journal of Chemical Kinetics, 8, 315-318.
- Machle, W., Scott, E.W. and Treon, J.F. (1940). The physiological response of animals to some simple mononitroparaffins and to certain derivatives of these compounds. J. Ind. Hyg. and Toxicol. 22, 315.
- MacLean, D.I. and Wagner, H. Gg. (1967). The structure of the reaction zones of ammonia-oxygen and hydrazine decomposition flames. Eleventh Symposium (International) on Combustion, The Combustion Institute, Pittsburgh, 871.
- Magee, P.N. and Barnes, J.M. (1956). The production of malignant primary hepatic tumors in the rat by feeding dimethylnitrosamine. Brit. J. Cancer, 10, 114-122.

- Magee, P.N. and Barnes, J.M. (1959). The experimental production of tumors in the rat by dimethylnitrosamine (N-nitroso dimethylamine). Acta Union Intl. Contra Cancrum, 15, 187-190.
- Magee, P.N. and Barnes, J.M. (1967). Carcinogenic nitroso compounds. Adv. Cancer Res., 10, 163-246.
- Malte, P.C., Halgren, C.A., Monteith, L.E., Corlett, R.C. and Pratt, D.T. (1976). The fate of organic nitrogen in jet-stirred combustion. Fall Meeting, Western States Section, The Combustion Institute, La Jolla, California.
- Malte, P.C. and Pratt, D.T. (1973). Oxides of nitrogen formation for fuel-lean jet-stirred carbon monoxide combustion. Presented at the Fall Meeting of the Western States Section, The Combustion Institute, El Segundo, California.
- Martin, G.B. and Berkau, E.E. (1971). An investigation of the conversion of various fuel nitrogen compounds to  $\text{NO}_x$  in oil combustion. AICHE National Meeting, Session: The Combustion Process and Air Pollution, Atlantic City, New York, August.
- Matthews, R.D. (1972). Distributions of  $\text{NO}$ ,  $\text{NO}_2$ , and  $\text{NO}_x$  in a model gas turbine combustor. M.S. Thesis, Department of Mechanical Engineering, University of California, Berkeley.
- Matthews, R.D., Sawyer, R.F. and Schefer, R.W. (1977). Interferences in the chemiluminescent measurement of  $\text{NO}$  and  $\text{NO}_2$  emissions from combustion systems. Environmental Science and Technology (in press).
- MacDonald, W.E., Dekhmann, W.B. and Bernal, E. (1963). Subacute effects of vapors of nitro-olefins upon experimental animals. Amer. Ind. Hyg. Assoc. J., 24, 539-540.
- McElroy, M.B. (1975). Chemical processes in the solar system: a kinetic perspective. MTP International Review of Science.
- McKean, T. (1934). The carotid sinus as an etiological factor in sudden anesthetic death. Am. Surg., 99, 974.
- McLean, E., Bras, G. and McLean, A.E.M. (1965). Venous occlusions in the liver following dimethylnitrosamine. Brit. J. Expl. Path., 46, 367-369.
- McNerney, J.H. and Schrenk, H.H. (1960). The acute toxicity of cyanogen. Amer. Ind. Hyg. Assoc. J., 21, 121-124.
- Mellor, A.M. (1972). Current kinetic modeling techniques for continuous flow combustors. In: Emissions from Continuous Combustion Systems, Cornelius, W. and Agnew, W.G. (eds.), Plenum, New York, p.23.
- Mellor, A.M. (1976). Gas turbine engine pollution. Prog. Energy Combust. Sci., 1, 111-133.

- Merryman, E.L. and Levy, A. (1973).  $\text{NO}_x$  formation in combustion: anomalous early  $\text{NO}_2$  formation. Presented at the Third International Clean Air Congress, Dusseldorf, West Germany.
- Merryman, E.L. and Levy, A. (1974). Nitrogen oxide formation in flames: the roles of  $\text{NO}_2$  and fuel nitrogen. Fifteenth Symposium (International) on Combustion, The Combustion Institute, Pittsburgh, 1073.
- Miller, S.G. (1975). The role of atmospheric nitrogen dioxide in carcinogenesis. AVRAM Company Report, Falls Church, Virginia.
- Mirvish, S.S. (1970). Kinetics of dimethylamine nitrosation in relation to nitrosamine carcinogenesis. J. Nat. Cancer Inst. 44, 633.
- Mirvish, S.S. (1971). Kinetics of nitrosamide formation from alkylureas, N-alkylurethans, and alkylguanidines: possible implications for the etiology of human gastric cancer. J. Nat. Cancer Inst. 46, 299-340.
- Miyauchi, T., Mori, Y. and Imamura, A. (1977). A study of nitric oxide formation in fuel-rich hydrocarbon flames: roles of cyanide species, H, OH and O. Sixteenth Symposium (International) on Combustion, The Combustion Institute, Pittsburgh, 1073.
- Moiseev, G.E. and Benemanskii, V.V. (1975). Carcinogenic activity of low concentrations of nitrosodimethylamine in inhalation. Vopr. Omkol., 21, 6, 107 (Chem. Abstr. 83, 173618Z, 1975).
- Moore, S. and Gates, M. (1946). Summary Technical Report of Division 9. National Defense Research Committee, 1.
- Morgan, W.K.C. and Seaton, A. (1975). Occupational Lung Disease. Saunders, London, U.K.
- Morley, C. (1976). The formation and destruction of hydrogen cyanide from atmospheric and fuel nitrogen in rich atmospheric pressure flames. Combustion and Flame 27, 189-204.
- Mosier, S.A. and Roberts, R. (1974). Low power turbo propulsion combustor exhaust emissions. Vol. II: Demonstration and total emission analysis and prediction. AFAPL-TR-73-36.
- Mosier, S.A., Roberts, R. and Henderson, R.E. (1973). Development and verification of an analytical model for predicting emissions from gas turbine engine combustors during low-power operation. Atmospheric Pollution by Aircraft Engines, AGARD CP No. 125.
- Mulvihill, J.N. and Phillips, L.F. (1975). Breakdown of cyanogen in fuel-rich  $\text{H}_2/\text{N}_2/\text{O}_2$  flames. Fifteenth Symposium (International) on Combustion, The Combustion Institute, Pittsburgh, 1113.
- Muzio, L.J., Arand, J.K., Teixeira, D.P. (1977). Gas phase decomposition of nitric oxide in combustion products. Sixteenth Symposium (International) on Combustion. The Combustion Institute, Pittsburgh, 199.

- Myerson, A.L. (1975). The reduction of nitric oxide in simulated combustion effluents by hydrocarbon-oxygen mixtures. Fifteenth Symposium (International) on Combustion, 1085-1092.
- Myerson, A.L. and Blair, D.W. (1976). Reduction of nitric oxide in automobile engine exhaust by ethane-air injection, Environmental Science and Technology 10, 5, 461-466.
- Nadler, M.P., Wang, V.K. and Kaskan, W.E. (1970). The decay of radicals in ammonia-oxygen-nitrogen flames. Journal of Physical Chemistry, 70, 917.
- National Defense Research Committee (1942). Office of Scientific Research and Development, 2.
- Nelson, W.L. (1958). Petroleum Refinery Engineering, fourth edition. McGraw Hill, New York, NY.
- Nicolet, M. and Vergison, E. (1971). Aeronom. Acta, 90, 1.
- Noguchi, M., Sanda, S. and Nakamura, N. (1976). Development of Toyota lean burn engine. SAE Paper No. 760757.
- Nuerath, G., Pirmann, B., Luttich, H. and Wichern, H. Zur frage der N-Nitrosoverbindungen im tabakrauch, II. Beitr. Tabakforsch. 3, 251.
- Olishifski, J.B. and McElroy, F.E. (1971). Fundamentals of Industrial Hygiene, National Safety Council, Chicago.
- Otto, K., Shelef, M. and Kummer, J.T. (1971). Studies of surface reactions of NO by isotope labeling. II. Deuterium kinetic isotope effect in the ammonia--nitric oxide reaction on a supported platinum catalyst. J. Phys. Chem. 75, 875-879.
- Otto, K. Shelef, M. and Kummer, J.T. (1970). Studies of surface reactions of nitric oxides by nitrogen-15 isotope labeling. I: The reaction between nitric oxide and ammonia over supported platinum at 200-250°. J. Phys. Chem. 4, 2690-2698.
- Oven, M.J., McLean, W.J. and Gouldin, F.C. (1977). NO-NO<sub>2</sub> measurements in a methane-fueled swirl-stabilized combustor. Presented at the Spring meeting of the Central States Section of the Combustion Institute, NASA Lewis.
- Patty, F.A. (1949). Industrial Hygiene and Toxicology, Interscience, New York.
- Pereira, F.J., Beer, J.M., Gibbs, B. and Hedley, A.B. (1975). NO<sub>x</sub> emissions from fluidized bed coal combustors. Fifteenth Symposium (International) on Combustion, The Combustion Institute, Pittsburgh, 1149.

- Pershing, D.W. and Wendt, J.O.L. (1977). Pulverized coal combustion; the influence of coal composition on thermal and fuel  $\text{NO}_x$ . The Sixteenth Symposium (International) on Combustion, Combustion Institute Pittsburgh, 389.
- Pfefferle, W.C., Heck, R.M., Carrubba, R.V. and Roberts, G.W. (1975). Catathermal combustion: a new process for low emission fuel conversion. ASME Report No. 75-WA/Fu-1.
- Pierotti, D. and Rasmussen, R.A. (1976). Combustion as a source of nitrous oxide in the atmosphere. Geophysical Research Letters 3, 5, 265-267.
- Pitts, J.N. (1977). personal communication.
- Pitts, J.N., Smith, J.P., Fitz, D.R. and Grosjean, D. (1977). Enhancement of photochemical smog by N, N-Diethylhydroxylamine in polluted ambient air. Science 197, 255-257.
- Pohl, J.H. and Sarofim, A.F. (1977). Kinetics of devolatilization and oxidation of coal nitrogen. Sixteenth Symposium (International) on Combustion, The Combustion Institute, Pittsburgh, 491.
- Pozniak, D.J. (1975). Exhaust port fuel injection for chemical reduction of nitric oxide. SAE Paper No. 750173. Automotive Engineering Congress, Detroit, Michigan.
- Pozzani, U.C., Carpenter, C.P., Palm, P.E., Weil, C.S. and Nair, J.H. (1959). Mammalian toxicity of acetonitrile. J. Occ. Med., 1, 634.
- Pratt, D.T. and Malte, P.C. (1975). Formation of thermal and prompt  $\text{NO}_x$  in a jet-stirred combustor. AIChE Symposium Series 71, 148, 150-157.
- Prentiss, A.M. (1951). Civil Defense in Modern War. McGraw-Hill, New York.
- Puechberty, D. and Cottureau, M.J. (1977). Measurement of absolute number density profiles of CN in a low pressure flame. Combustion and Flame 29, 99-102.
- Renzetti, N.A. and Doyle, D.J. (1960). Photochemical aerosol formation in sulfurdioxide-hydrocarbon systems. Intern. J. Air Pollution 2, 327.
- Ripperton, L.A. and Johnston, D.R. (1959). Effects on growing animals of a continuous exposure to experienced concentrations of nitrogen dioxide. Am. Ind. Hyg. Assoc. J. 20, 324-326.
- Rodale, J.J. (1964). Our Poisoned Earth and Sky. Rodale Books, Emmaus, Pennsylvania, 493.
- Roquemore, W.M. and Hodgson, F.N. (1975). Fluorescence of hydrocarbons in jet engine exhaust. Paper No. 27-4, International Conference on the Sensing of Environmental Pollutants. Las Vegas, Nevada.

- Rupe, R. (1973). Hydrogen enrichment of hydrocarbon fuels as a means for obtaining low emissions and high thermal efficiency in a spark ignition engine. Presented at the Fall meeting of the Western States Section of the Combustion Institute.
- Rylander, R. (1973). Toxicity of cigarette smoke components: free lung cell response in acute exposures. Am. Rev. Resp. Disease 108, 1279-1282.
- Sarofim, A.F. and Flagan, R.C. (1976). NO<sub>x</sub> control for stationary combustion sources. Prog. Energy Comb. Sci. 2, 1-25.
- Sawyer, R.F., Brown, N.J., Matthews, R.D., Branch, M.C. and Banna, S.M. (1976). The formation of nitrogen oxides from fuel nitrogen. Electric Power Research Institute, Report EPRI 223-1.
- Sawyer, R.F., McLean, W.J. and Maes, C.M. (1972). The production of nitric oxide in ammonia oxidation flames. Combustion Science and Technology 6, 47.
- Sax, N.I. (1974). Industrial Pollution. Van Nostrand Reinhold, New York.
- Schefer, R.W. (1976). Pollutant formation in recirculating reacting flows. Ph.D. Thesis, Department of Mechanical Engineering, University of California, Berkeley.
- Schefer, R.W., Matthews, R.D., Cernansky, N.P. and Sawyer, R.F. (1973). Measurement of NO and NO<sub>2</sub> in combustion systems. Paper No. WSCI 73-31, presented at the Fall meeting of the Western States Section of the Combustion Institute, El Segundo, California.
- Schefer, R.W. and Sawyer, R.F. (1977). Lean premixed recirculating flow combustion for control of oxides of nitrogen. Sixteenth Symposium (International) on Combustion, The Combustion Institute, Pittsburgh, 119.
- Schuchmann, H.P. and Laidler, K.J. (1972). Nitrogen compounds other than NO in automobile exhaust gas. J. APCA 22, 1, 52.
- Schwartz, L. (1945). Skin hazards in the manufacture and processing of synthetic rubber. J. Am. Med. Assoc. 127, 389.
- Seery, D.J. and Zabielsky, M.F. (1977). Mass spectrometer probing of a CO-NH<sub>3</sub>-O<sub>2</sub> flame. Combustion and Flame 28, 93-99.
- Seinfeld, J.H. (1975). Air Pollution: Physical and Chemical Fundamentals. McGraw-Hill, New York, p. 415.
- Seizinger, D.E. and Dimitriades, B. (1972). Oxygenates in exhaust from simple hydrocarbon fuels. J. APCA 22, 1, 47-51.

- Sen, N.P. and Donaldson, B.C. (1973). The effect of ascorbic acid and glutathione on the formation of nitrosopiperazines from piperazine adipate and nitrite. In N-Nitroso Compounds: Analysis and Formation Bogovski, P., Preussmann, R. and Walker, E.A., editors. IARC Scientific Publication No. 9, Lyon, France.
- Shapley, D. (1976). Nitrosamines: scientists on the trail of prime suspect in urban cancer. Science 191, 268-270.
- Shapley, D. (1977). Will fertilizers harm ozone as much as SST's? Science 195, 658.
- Shaw, J.T. and Thomas, A.C. (1968). Oxides of nitrogen in relation to the combustion of coal. Presented at the Seventh International Conference on Coal Science, Prague, Czechoslovakia.
- Shimkin, M.B., DeLorimier, A.A., Mitchell, J.R. and Burroughs, T.P. (1954). Appearance of carcinoma following single exposure to a refrigeration ammonia-oil mixture. AMA Arch. Ind. Health 9, 186.
- Shy, C.M., Creason, J.P., Pearlman, M.E., McClain, K.E., Benson, F.B. and Young, M.M. (1970a). The Chattanooga school children study: effects of community exposure to nitrogen dioxide. I: Methods, descriptions of pollutant exposure, and results of ventilatory function testing. J. Air Pollution Control Admin. 20, 539-545.
- Shy, C.M., Creason, J.P., Pearlman, M.E., McLain, K.E., Benson, F.B. and Young, M.M. (1970b). The Chattanooga school children study: effects of community exposure to nitrogen dioxide. II: Incidence of acute respiratory illness. J. Air Pollution Control Admin. 20, 582-588.
- Siegmund, C.W. and Turner, D.W. (1974). NO<sub>x</sub> emissions from industrial boilers: potential control methods. Journal of Engineering for Power, Transactions of the ASME.
- Sievers, R.E., Blacks, M.S., Rehg, W.R. and Brooks, J.J. (1976). Analysis of the hydrocarbon fraction of jet engine exhaust by subtractive gas chromatography. Paper No. 27-3. International Conference on the Sensing of Environmental Pollutants. Las Vegas, Nevada.
- Siewert R. (1975). Hydrogen interference in chemiluminescent NO<sub>x</sub> analysis. Combustion and Flame 25, 273-276.
- Silverstein, A. and Hall, E.W. (1955). Liquid hydrogen as a jet fuel for high altitude aircraft. NACA RM E55C28A.
- Siminski, V.J. and Shaw, H. (1977). Development of a hybrid catalytic combustor. ASME Report No. 77-AT-84.

- Smith, O.I. and Sawyer, R.F. (1976a). The thermal oxidation of methalamine. Presented at the Spring meeting of the Western States Section of the Combustion Institute, Salt Lake City, Utah.
- Smith, O.I. and Sawyer, R.F. (1976b). The thermal pyrolysis of methalamine. Presented at the Spring meeting of the Western States Section of the Combustion Institute.
- Smyth, H.F., Jr. (1956). Hygienic standards for daily inhalation. Am. Ind. Hyg. Quart. 17, 145.
- Smyth, H.F., Carpenter, C.P. and Weil, C.S. (1951). Range finding toxicity data: List IV. AMA Arch. Ind. Hyg. Occ. Med. 4, 119-122.
- Smyth, H.F., Carpenter, C.P., Weil, C.S., Pozzani, U.C. and Striegel, J.A. (1962). Range finding toxicity data: List VI. Am. Ind. Hyg. Assoc. J. 23, 95-101.
- Stebar, R.F. and Parks, F.B. (1974). Emission control with lean operation using hydrogen supplemental fuel. SAE Paper No. 740187.
- Stephens, E.R. and Price M.A. (1965). Search for some nitro-olefins in polluted air. J. Air Poll. Cont. Assoc. 15, 320-322.
- Sterner, J.H. (1949). The cyanides and cyanogen compounds. In Hygiene and Toxicology, Patty, F.A., editor, Reinhold, New York, pp. 631-632.
- Stockburger, L., Sie, B.K.T. and Heicklen, J. (1975). The inhibition of photochemical smog. V. Products of the diethyl hydroxylamine inhibited reaction. Report 407-75. Center for Air Environment Studies, Pennsylvania State University.
- Stumpf, S.A. and Blazowski, W.S. (1976). Detailed investigations of organic compound emissions from aircraft gas turbine engines. Paper No. 27-1. International Conference on the Sensing of Environmental Pollutants. Las Vegas, Nevada.
- Surgeon General (1962). Motor Vehicles, Air Pollution, and Health. U.S. Dept. of Health, Education and Welfare, Public Health Service.
- Takagi, T., Ogasawara, M., Daizo, M., Tatsumi, T. (1977). NO<sub>x</sub> formation from nitrogen in fuel and air during turbulent diffusion combustion. Sixteenth Symposium (International) on Combustion, The Combustion Institute, Pittsburgh, 181.
- Tebbens, B.D. (1966). Air pollutants measured for various periods of time. Experimental Biology, Bethesda: Fed. Am. Soc. Exp. Biology, p. 273.
- Terracini, B., Magee, P.N. and Barnes, J.M. (1967). Hepatic pathology in rats on low dietary levels of dimethylnitrosamine. Brit. J. Cancer, 21, 559-565.

- Train, R.E. (1977). Environmental cancer. Science 195, 4277, 1.
- Troth, D.C., Verdouw, A.J., Williams, J.R. and Dodd, R.G. (1974). Investigation of aircraft gas turbine combustors having low mass emissions. ASME Paper No. 74-GT-36.
- Turner, G.S. (1974). Eliminating errors in chemiluminescence NO<sub>x</sub> determination in automobile exhaust. Society of Automotive Engineers, Paper No. 741032.
- Turner, D.W., Andrews, R.L. and Siegmund, C.W. (1972). Influence of combustion modification and fuel nitrogen content on nitrogen oxides emissions from fuel oil combustion. Combustion, 21-30.
- Tuttle, J.H., Shisler, R.A., and Mellor, A.M. (1974). Nitrogen dioxide formation in gas turbine engines: measurements and measurement methods. Combustion Science and Technology 9, 261-271.
- Underhill, F.P. and Koppanyi, T. (1936). Toxicology. P. Blakiston's Son, Philadelphia. pp. 46-50.
- U.S. Public Health Service (1966). Atmospheric emissions from nitric acid manufacturing processes. PHS Publ. No. 999-AP-27.
- U.S. Navy (1975). The production and refining of 10,000 barrels of crude shale oil into military fuels, Executive Summary Report. Contract N00014-75C-0055, Applied Systems Corp., Vienna, Virginia.
- Valade, P. (1952). Injuries to the central nervous system in chronic experimental poisoning by hydrocyanic acid gas. Bull. Acad. Nat. Med. 136, 280. Abstracted in Archives of Industrial Hygiene and Occupational Medicine 7, 265.
- Verkamp, F.J., Verdouw, A.J. and Tomlinson, J.G. (1974). Impact of emission regulations on future gas turbine engine combustors. J. Aircraft 11, 340.
- Vigdortschik, N.A., Andreeva, E.C., Matuswitch, K., Nikulina, M.M., Frumina, L.M. and Striter, V.A. (1937). Symptomatology of chronic poisoning with oxides of nitrogen. J. Ind. Hyg. Toxicol. 19, 469.
- Vigliani, E.C. and Zurlo, N. (1956). Abstracted in Arch. Ind. Health 13 403.
- Voorhoeve, R.J.H., Patel, C.K.N., Trimble, L.E. and Kerl, R.J. (1975). Hydrogen cyanide production during reduction of nitric oxide over platinum catalysts, Science 190, No. 4210, 149.
- Voorhoeve, R.J.H., Remeika, J.P. and Johnson, D.W. (1973). Rare-earth manganites: catalysts with low ammonia yield in the reduction of nitrogen oxides. Science 180, 62-64.

- Wagner, J.P. (1972). Survey of toxic species evolved in the pyrolysis and combustion of polymers. Fire Research Abstracts and Reviews 14, 1-23.
- Wampler, F.B., Clark, D.W. and Gaines, F.A. (1976). Catalytic combustion of  $C_3H_8$  on Pt coated monolith. Combustion Science and Technology 14, 25-31.
- Wang, W.C., Yung, Y.L., Lacin, A.A., Mo, T. and Hansen, J.E. (1976). Greenhouse effects due to man-made perturbations of trace gases. Science 194, 4266, 685-690.
- Wasserberger, M.S., Radomski, J.L. and Deichmann, W.B. (1970). Nitro-olefins, combustion products of hydrocarbons. Industrial Medicine 39, 49-52.
- Weatherby, J.H. (1952). Chronic toxicity of ammonia fumes by inhalation. Proc. Soc. Exptl. Biol. Med. 81, 300-301.
- Weiss, R.F. and Craig, H. (1976). Production of atmospheric nitrous oxide by combustion. Geophysical Research Letters 3, 12, 751-753.
- Wendt, J.O.L. and Sternling, C.V. (1974). Effect of ammonia in gaseous fuels on nitrogen oxide emissions. Journal of the Air Pollution Control Association 24, 11, 1055.
- Wendt, J.O.L., Sternling, C.V. and Matovich, M.A. (1973). Reduction of sulfur trioxide and nitrogen oxides by secondary fuel invection. Fourteenth Symposium (International) on Combustion, The Combustion Institute, Pittsburgh, 897-904.
- Wetherhold, J.M., Linch, A.L. and Charsha, R.C.C. (1960). Chemical cyanosis--causes, effects, and prevention. Arch. Envir. Health 1, 353-361.
- Williamson, S.J. (1973). Fundamentals of Air Pollution. Addison-Wesley, Menlo Park, California.
- Wilson, R.H. (1944). Health hazards encountered in the manufacture of synthetic rubber. J. Am. Med. Assoc. 124, 701.
- Wolfsie, J.H. and Shaffer, C.B. (1959). Hydrogen cyanide. J. Occ. Med. 1, 281-288.
- Wooley, W.D. (1972). Nitrogen-containing products from the thermal decomposition of flexible polyurethane foams. Brit. Polymer J. 4, 27-43.
- Woolsey, S. (1977). Personal communication. Center for Earth and Planetary Physics, Harvard University.

Yamagishi, K, Nozawa, M., Yoshie, T., Tokamoto, T, and Kakegawa Y. (1975).  
A study of  $\text{NO}_x$  emission characteristics in two stage combustion.  
Fifteenth Symposium (International) on Combustion, The Combustion  
Institute, Pittsburgh, 1157.

Yanagi, T. (1977). Effects of probe sampling rates on sample composition.  
Combustion and Flame 28, 33-44.

This report was done with support from the Department of Energy. Any conclusions or opinions expressed in this report represent solely those of the author(s) and not necessarily those of The Regents of the University of California, the Lawrence Berkeley Laboratory or the Department of Energy.

TECHNICAL INFORMATION DEPARTMENT  
LAWRENCE BERKELEY LABORATORY  
UNIVERSITY OF CALIFORNIA  
BERKELEY, CALIFORNIA 94720