

# Lawrence Berkeley National Laboratory

## Recent Work

### Title

NONLINEAR OPTICS WITH SURFACE ELECTROMAGNETIC WAVES

### Permalink

<https://escholarship.org/uc/item/39h5c9vd>

### Author

Shen, Y.R.

### Publication Date

1978-09-01

Presented at the First International  
School on Laser Application in Atomic  
Molecular and Nuclear Physics  
Vilnius, USSR, August, 1978

LBL-8223

c.2

NONLINEAR OPTICS WITH  
SURFACE ELECTROMAGNETIC WAVES

Y. R. Shen

September 1978

DEC 19 1978

Prepared for the U. S. Department of Energy  
under Contract W-7405-ENG-48

**TWO-WEEK LOAN COPY**

*This is a Library Circulating Copy  
which may be borrowed for two weeks.  
For a personal retention copy, call  
Tech. Info. Division, Ext. 6782*

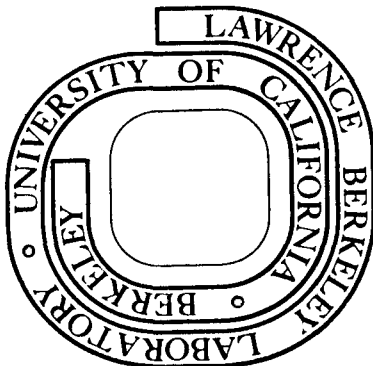

LBL-8223  
c.2

## **DISCLAIMER**

This document was prepared as an account of work sponsored by the United States Government. While this document is believed to contain correct information, neither the United States Government nor any agency thereof, nor the Regents of the University of California, nor any of their employees, makes any warranty, express or implied, or assumes any legal responsibility for the accuracy, completeness, or usefulness of any information, apparatus, product, or process disclosed, or represents that its use would not infringe privately owned rights. Reference herein to any specific commercial product, process, or service by its trade name, trademark, manufacturer, or otherwise, does not necessarily constitute or imply its endorsement, recommendation, or favoring by the United States Government or any agency thereof, or the Regents of the University of California. The views and opinions of authors expressed herein do not necessarily state or reflect those of the United States Government or any agency thereof or the Regents of the University of California.

Proceedings of the First International  
School on Laser Application in Atomic  
Molecular and Nuclear Physics  
Vilnius, USSR, August, 1978

LBL-8223

NONLINEAR OPTICS WITH  
SURFACE ELECTROMAGNETIC WAVES

Y. R. Shen

Physics Department  
University of California  
Berkeley, California 94720

and

Materials and Molecular Research Division  
Lawrence Berkeley Lab  
Berkeley, California 94720

SEPTEMBER, 1978

In recent years, stimulated by the growing interest in surface physics, the problems of surface electromagnetic waves on metals and semiconductors have attracted a great deal of attention.<sup>1</sup> By definition, a surface em wave is an em wave propagating along the surface with its intensity decaying exponentially away from the surface as is schematically shown in Fig. 1. Since the exponential decay lengths into adjoining media are of the order of the optical wavelength, the surface wave characteristics are in fact mainly determined by the bulk dielectric constants of the two media. Nevertheless, they are sensitive to perturbations on the surface. Thus, for example, surface em waves have been used to detect the presence of a submonolayer of absorbed gas on metals.<sup>2</sup>

The propagation of the surface em wave is of course governed by the wave equation together with the usual boundary conditions.<sup>3</sup> Consider, for simplicity, two isotropic media bounded by an infinite plane surface. The wave equation is

$$\nabla \times (\nabla \times \vec{E}) + (\omega^2 \epsilon / c^2) \vec{E} = \vec{S}(\omega) \quad (1)$$

where  $S$  is a source term for the  $\vec{E}(\omega)$  field. With  $S = 0$ , the free wave solution of the equation is

$$\begin{aligned} \vec{E} &= (\hat{x}\epsilon_{ax}^0 + \hat{z}\epsilon_{az}^0) \exp(i\vec{k}_a \cdot \vec{r}) && \text{in medium a} \\ &= (\hat{x}\epsilon_{bx}^0 + \hat{z}\epsilon_{bz}^0) \exp(i\vec{k}_b \cdot \vec{r}) && \text{in medium b} \end{aligned}$$

assuming both  $\vec{E}$  and  $\vec{k}$  are in the  $\hat{x} - \hat{z}$  plane (TM wave). The boundary

conditions at the surface are

$$\begin{aligned} \mathcal{E}_{ax}^0 &= \mathcal{E}_{bx}^0 \\ \epsilon_a \mathcal{E}_{az}^0 &= \epsilon_b \mathcal{E}_{bz}^0 \quad \text{or} \quad \epsilon_a \left( \frac{k_{ax}}{k_{az}} \right) \mathcal{E}_{ax}^0 = - \epsilon_b \left( \frac{k_{bx}}{k_{bz}} \right) \mathcal{E}_{bx}^0 \end{aligned} \quad (2)$$

where  $k_{ax} = k_{bx} \equiv k_x$ , and  $k_{az} = [k_a^2 - k_x^2]^{1/2} = i\alpha_a$  and  $k_{bz} = [k_b^2 - k_x^2]^{1/2} = -i\alpha_b$  are both purely imaginary for a surface wave (see Fig. 1) if  $\epsilon_a$  and  $\epsilon_b$  are real, and  $k_{a,b}^2 = \omega^2 \epsilon_{a,b} / c^2$ . In order to have nonzero solution of  $\mathcal{E}_a^0$  and  $\mathcal{E}_b^0$ , Eq. (2) requires  $\epsilon_a k_{bz} + \epsilon_b k_{az} = 0$  which can be rewritten in the form

$$k_x^2 = K_x^2 \equiv (\omega^2 / c^2) [\epsilon_a \epsilon_b / (\epsilon_a + \epsilon_b)] \quad (3)$$

This is actually the dispersion relation for the surface wave provided  $k_x^2 > k_{a,b}^2$  or  $\epsilon_a \epsilon_b / (\epsilon_a + \epsilon_b) > \epsilon_{a,b}$ . The latter condition can be satisfied if either  $\epsilon_a$  or  $\epsilon_b$  is negative. If  $\epsilon_b < 0$ , then  $|\epsilon_b|$  must be larger than  $\epsilon_a$ . A negative dielectric constant exists below the plasma frequency in metals or in the reststrahlung band of a solid. More generally, the source term  $S$  in Eq. (1) is nonzero. If  $S$  oscillating at frequency  $\omega$  has a wave vector component along  $\hat{x}$  equal to  $k_x$  given by Eq. (3), then the surface wave can be excited resonantly as we shall see later.

Since the surface em wave is confined to the surface, it will not leak out into bulk radiation unless the surface is subject to perturbation or imperfection. This follows directly from the requirement of matching of  $k_x$  along the surface. Conversely, it is also impossible to

excite the surface wave by shining a light beam of the same frequency directly on a smooth surface. Thus, in order to study the surface wave properties, various excitation and detection methods have been devised, namely, inelastic electron scattering,<sup>4</sup> Raman scattering,<sup>5</sup> and linear<sup>6</sup> and nonlinear<sup>7-9</sup> optical excitation and detection.

In the linear optical excitation and detection, the coupling between the surface wave and the bulk radiation mode is achieved through perturbation on the surface. The so-called Otto method<sup>6</sup> uses a prism to couple the surface wave and the bulk radiation. The prism sits on top of the surface with a small gap of the order of a wavelength. The coupling is established through the evanescent wave in the gap. A variation of the method is to use a grating deposited on the surface instead of the prism for the radiation coupling. In fact, surface roughness can be regarded as a random grating and is therefore also effective in establishing the coupling, although the coupling efficiency is rather small. An alternative method due to Kreschmann<sup>6</sup> uses a film deposited on a prism. The surface wave on the surface between the film and the surrounding medium can be coupled to the bulk radiation mode in the prism through the film. In these linear methods, the surface is clearly perturbed; consequently, the surface wave becomes radiative and its dispersion curve is slightly modified. Such difficulty can in principle be avoided in the nonlinear optical excitation and detection method.<sup>7-9</sup> As we shall discuss here, the nonlinear optical method also offers the advantage of being able to measure directly the resonant frequency and the damping constant of the surface wave.

In the nonlinear optical scheme, the surface wave is excited by

beating of two laser beams at  $(\vec{k}_1, \omega_1)$  and  $(\vec{k}_2, \omega_2)$  which create a non-linear polarization  $P^{NL}(\omega = \omega_1 \pm \omega_2)$  in, for example, medium "b". This nonlinear polarization acts as a source for the E field at  $\omega$ , i.e.,  $\vec{S} = -4\pi(\omega^2/c^2)P^{NL}(\omega)$  in Eq. (1). The general solution of Eq. (1) with the plane surface boundary conditions has been worked out by Bloembergen and Pershan for the case of sum- or difference-frequency generation near a plane boundary.<sup>10</sup> The solution consists of two parts: a particular solution  $\vec{E}_p \exp(i\vec{k}_s \cdot \vec{r})$  with  $\vec{k}_s = \vec{k}_1 \pm \vec{k}_2$  representing the driven bulk wave at  $\omega$  in medium "b" and a homogeneous solution  $\vec{E}_0^{(a)} \exp(i\vec{k}_a \cdot \vec{r})$  in medium "a" and  $\vec{E}_0^{(b)} \exp(i\vec{k}_b \cdot \vec{r})$  in medium "b". We have explicitly

$$\begin{aligned} \vec{E}_p &= -4\pi \epsilon_b^{-1} (k_s^2 - k_b^2)^{-1} \left\{ \hat{x} [-P_x^{NL} k_{bz}^2 + P_z^{NL} k_x k_{sz}] + \right. \\ &\quad \left. \hat{z} [P_x^{NL} k_x k_{sz} + P_z^{NL} (k_{sz}^2 - k_b^2)] \right\} \\ \vec{E}_0^{(a)} &= \frac{-4\pi(\hat{x}k_{az} + \hat{z}k_x)}{(\epsilon_a k_{bz} + \epsilon_b k_{az})(k_s^2 - k_b^2)} [P_x^{NL} (k_s^2 - k_b^2) - \\ &\quad (k_{bz} + k_{sz})(k_{sz} P_x^{NL} - k_x P_z^{NL})] \\ \vec{E}_0^{(b)} &= \frac{4\pi(\hat{x}k_{bz} + \hat{z}k_x)\epsilon_a}{\epsilon_b(\epsilon_a k_{bz} + \epsilon_b k_{az})(k_s^2 - k_b^2)} [P_x^{NL} (k_s^2 - k_b^2) - \\ &\quad \left( \frac{\epsilon_b}{\epsilon_a} k_{az} - k_{sz} \right) (k_{sz} P_x^{NL} - k_x P_z^{NL})] \end{aligned} \quad (4)$$

Two denominator factors appear in the above equations. As is well known, the vanishment of  $(k_s^2 - k_b^2)$  corresponds to the phase-matched generation of the field at  $\omega$  in medium "b". The other denominator factor  $(\epsilon_a k_{bz} +$



$\epsilon_b k_{az}$ ) is usually always positive if  $\epsilon_a$  and  $\epsilon_b$  are both positive, and therefore does not play any important role in the ordinary sum- and difference-frequency generation process. However, as we showed earlier,  $\epsilon_a k_{bz} + \epsilon_b k_{az} = 0$  actually describes the dispersion of the surface wave when either  $\epsilon_a$  or  $\epsilon_b$  is negative. Therefore the vanishment of  $(\epsilon_a k_{bz} + \epsilon_b k_{az})$  in the denominator of  $\vec{\epsilon}_0$  should correspond to the resonance excitation of the surface wave.

More rigorously, since  $\epsilon_a$  and  $\epsilon_b$  are generally complex, we should write

$$\epsilon_a k_{bz} + \epsilon_b k_{az} = [(\epsilon_a^2 - \epsilon_b^2) / (\epsilon_a k_{bz} - \epsilon_b k_{az})] 2K'_x (-\Delta k_x + iK''_x)$$

where

$$K_x = K'_x + iK''_x = (\omega/c) [\epsilon_a \epsilon_b / (\epsilon_a + \epsilon_b)]^{1/2}$$

$$\Delta k_x = k_{sx} - K'_x \quad (5)$$

Physically,  $\Delta k_x$  is the phase mismatch in the surface wave excitation,  $\Delta k_x = 0$ , corresponds to exact resonance, and  $K''_x$  is the damping constant for the surface wave. The excited surface wave with the wavevector component  $k_x$  along the surface has an amplitude

$$\vec{\epsilon}_0^{(a,b)} \propto (-\Delta k_x + iK''_x)^{-1} \quad (6)$$

Since  $k_x = k_{1x} \pm k_{2x}$  is completely prescribed by the wavevectors of the

two input laser beams and can be different from the wavevector  $K'_x$  of the free surface wave, we call  $\vec{E}_o^{(a,b)}$  in Eq. (6) a driven surface wave.

In the complete solution, we should however also include the free surface wave which is also a homogeneous solution of Eq. (1). Let the free surface wave be  $\vec{E}_f^{(a,b)} \exp(iK'_x x - \alpha_{a,b} z)$ . Then the complete surface wave solution is

$$\vec{E}_{\text{sur}}^{(a,b)} = \vec{E}_o^{(a,b)} \exp(i\vec{k}_{a,b} \cdot \vec{r}) + \vec{E}_f^{(a,b)} \exp(iK'_x x - \alpha_{a,b} z) \quad (7)$$

Since  $\vec{E}_o^{(a,b)}$  is known,  $\vec{E}_f^{(a,b)}$  can be calculated from the boundary condition along  $\hat{x}$  on the surface. For example, assuming  $P^{\text{NL}} = \text{constant}$  for  $0 \leq x \leq \ell$  and  $P^{\text{NL}} = 0$  elsewhere and assuming  $k_x \cong K'_x$  so that  $k_{az} \cong i\alpha_a$  and  $k_{bz} \cong -i\alpha_b$ , we find

$$\begin{aligned} \vec{E}_{\text{sur}}^{(a,b)} &= 0 && \text{for } x \leq 0 \\ &= \vec{E}_o^{(a,b)} \left[ e^{i\Delta k_x x} - e^{-K''_x x} \right] e^{iK'_x x - \alpha_{a,b} z} && \text{for } 0 \leq x \leq \ell \\ &= \vec{E}_o^{(a,b)} \left[ e^{i\Delta k_x \ell} - e^{-K''_x \ell} \right] e^{iK'_x x - K''_x(x-\ell) - \alpha_{a,b} z} && \text{for } x \geq \ell \quad (8) \end{aligned}$$

where we have neglected the reflection of surface wave at  $x = 0$  and  $\ell$ .

This result is quite similar to the result for sum- or difference-generation in the bulk. In the present case, however, the free wave contribution is often negligible because of the large  $K''_x$ . Then, following Eqs. (6) and (8), the excited surface wave is given, to a good approximation, by

$$\vec{E}_{\text{sur}}^{\uparrow}(a,b) \propto (-\Delta k_x + iK_x'')^{-1} \exp(ik_x x - \alpha_{a,b} z) \text{ for } 0 \leq x \leq \ell$$

$$= 0 \quad \text{otherwise} \quad (9)$$

The excited surface wave can of course be detected by the linear optical coupling schemes we mentioned earlier, but it can also be detected by a nonlinear optical method. In the latter method, a probe beam  $E_3 \times \exp(i\vec{k}_3 \cdot \vec{r})$  at frequency  $\omega$  is directed onto the surface excitation region to beat with the excited surface wave. The beating creates a nonlinear polarization  $P^{\text{NL}}(\omega_4 = \omega \pm \omega_3)$  in medium "b". It then generates a coherent radiating field at  $\omega_4$  in the phase-matched direction determined by  $k_{4x} = k_x' \pm k_{3x}$ . Knowing the nonlinearity of the medium, the output power at  $\omega_4$  can easily be evaluated. This nonlinear detection method together with the nonlinear excitation constitutes a four-wave mixing process. Thus, in short, we have here a special case of the general four-wave mixing scheme for studying resonance excitations in a medium.<sup>11</sup>

Using either linear or nonlinear method to detect the nonlinearly excited surface wave, the output power is proportional to  $|E_{\text{sur}}|^2$  or

$$I \propto [(\Delta k_x)^2 + K_x''^2]^{-1} \quad (10)$$

which is a Lorentzian with its peak at  $\Delta k_x = 0$  and its half width given by  $K_x''$ . Measurements of  $I$  versus  $k_x$  at various  $\omega$  can therefore yield directly the dispersion characteristics  $K_x'(\omega)$  and  $K_x''(\omega)$  of the surface wave. Note that unlike the linear excitation method, the nonlinear excitation method allows us to map out the  $\omega - k_x$  space by varying  $\omega$  and  $k_x$ .

independently.

Study of surface em waves using the nonlinear optical method has been demonstrated in two cases. In the first case,<sup>8</sup> the surface phonon-polariton which lies in the phonon reststrahlung band was probed using the nonlinear excitation and detection method. The crystal under investigation was GaP. The output signal at  $\omega_4$  was estimated to be of the order of few tenths of a  $\mu\text{W}$  with 50 KW in the exciting and probe beams. The experimental arrangement is shown in Fig. 2, and typical data of  $I$  versus  $\Delta k_x$  fitted with Lorentzian curves shown in Fig. 3. The values of  $K'_x(\omega)$  and  $K''_x(\omega)$  deduced from the experimental results are presented in Fig. 4 in comparison with the theoretical curves derived from Eq. (5). The solid and the dashed curves correspond to a single-oscillator model and a multi-oscillator model for the dielectric constant of GaP respectively. Deviation of the experimental points of  $K''_x(\omega)$  from the theoretical curves at smaller  $\omega$  is mainly due to the divergence of the focused laser beams which sets a minimum to the width of the measured resonance peak. We notice that if the damping constant  $K''_x$  did not increase so rapidly as  $\omega$  approaches the longitudinal phonon frequency and the laser beams used had sufficiently narrow linewidths, then we would be able to probe the dispersion characteristics of the surface phonon-polaritons over a wavevector range from  $k_x = k_{1x} - k_{2x} \sim (\omega/c)\epsilon_b(\omega_1)$  to  $k_x = (k_{1x} + k_{2x}) \sim 2(\omega_1/c)\epsilon_b(\omega_1)$ .

In the second case,<sup>9</sup> the surface exciton-polariton in ZnO was probed. Since the exciton reststrahlung band of ZnO is in the ultraviolet, sum-frequency excitation of the surface wave should be used. In our experiment, we simply used one laser beam at  $\omega_1$  to excite the surface wave at

$\omega = 2\omega_1$ . Then, because the surface always appears to be somewhat rough on the scale of the uv wavelength, a certain fraction of the excited surface wave is expected to be scattered out by the surface roughness. Even if it is only a small fraction, the photodetector is so sensitive in the uv that the scattered radiation can easily be detected. This was actually the detection scheme we used. With a 50-KW dye laser pumped by a Q-switched ruby laser, we estimated an output signal of  $10^7$  photons/pulse assuming an output coupling coefficient of 1%. The experimental results connected to the C exciton in ZnO are shown in Figs. 5 and 6. Since ZnO is anisotropic, the dispersion relation of the surface wave takes a somewhat different form, e.g.,

$$K_x^2 = (\omega/c)^2 [\epsilon_a \epsilon_{bz} (\epsilon_{bx} - \epsilon_a) / (\epsilon_{bx} \epsilon_{bz} - \epsilon_a^2)] \quad (11)$$

In this case, two points are worth mentioning. First, Fig. 5 shows that the widths of the resonance peaks  $2K_x''$  are about two orders of magnitude smaller than  $K_x'$ . This means that even if the experimental data points are poorly scattered, the peak position  $K_x'$  can still be determined with an accuracy of about 1%. Second, since the surface exciton-polariton is only present at cryogenic temperature, application of the linear optical excitation and detection method is very difficult. The nonlinear optical excitation method we have described is, on the other hand, quite simple and straight forward.

The nonlinear optical method can of course also be used to study surface plasmons on metal surfaces. Simon and coworkers<sup>12</sup> have excited the surface plasmons at the fundamental frequency to enhance second-har-

monic generation from a metal surface. It is possible to nonlinearly excite the surface plasmon by sum-frequency mixing using the Otto or Kretschmann geometry<sup>13</sup> or by difference-frequency mixing using noncolinear laser beams impinging on the surface from the non-metal side. The optical nonlinearity of metals is generally small. Therefore, in order to enhance the nonlinear optical process, it is advisable to place a nonlinear crystal with a large second-order nonlinear susceptibility  $\chi^{(2)}$  on the metal surface.<sup>12,13</sup>

With laser excitation, intense surface em wave can be propagated along the surface. Then, observation of nonlinear interaction between surface em waves becomes possible. Nonlinear optics of surface waves is a field yet to be explored. Sum- and difference-frequency generation can be easily observed, but exact phase matching of such process is usually not possible in the case where the dispersion curve  $\omega$  versus  $K'_x$  concaves downward. Effects resulting from third-order nonlinear interaction between surface waves can also be observed. For example, using surface plasmons in a four-wave mixing scheme, the Raman resonances in a liquid film on the metal surface can be probed.<sup>13</sup>

The nonlinear optical method is probably most useful for studying surface em waves at cryogenic temperature. This is because of the difficulties inherent in the application of the linear method at low temperature. The surface wave characteristics are often very sensitive to the change in the dielectric constants of the adjoining media. It has therefore been proposed as a means to study phase transitions.<sup>14</sup> Then, with the nonlinear optical method, one can probably use the surface wave to study phase transitions at low temperature, for example, the normal-super-

conducting phase transitions in solids.

**Acknowledgement:**

This work was the result of collaboration between our group at Berkeley and Prof. F. DeMartini's group at the University of Rome. It was partially supported by the Division of Materials Sciences, Office of Basic Energy Sciences, U. S. Department of Energy, and by a NATO D2417 joint program between Università di Roma and University of California at Berkeley.

References

1. See, for example, review articles by D. L. Mills and E. Burstein, Report on Progress in Physics 37, 817 (1974); R. H. Ritchie, Surface Science 34, 1 (1973); E. Burstein, W. P. Chen, Y. J. Chen, and A. Hartstein, J. Vac. Sci. Technol. 11, 1004 (1974); V. M. Agranovitch, Sov. Phys. Uspekki [English translation] 18, 99 (1975).
2. W. H. Weber, Phys. Rev. Lett. 39, 153 (1977).
3. J. Zenneck, Ann. Phys. 23, 846 (1907); A. Sommerfeld, Ann. Phys. 28, 665 (1909).
4. H. Ibach, Phys. Rev. Lett. 24, 1416 (1970); 27, 253 (1971).
5. D. J. Evans, S. Ushioda, and J. C. McMullen, Phys. Rev. Lett. 31, 369 (1973); J.-Y. Pricur and S. Ushioda, Phys. Rev. Lett. 34, 1012 (1975).
6. A. Otto, Z. Phys. 216, 398 (1968); E. Kretschmann, Z. Physik 241, 313 (1971); N. Marschall and B. Fischer, Phys. Rev. Lett. 28, 811 (1972); A. S. Barker, Phys. Rev. Lett. 28, 892 (1972); L. Lagois and B. Fischer, Phys. Rev. Lett. 36, 680 (1976); E. Burstein, in "Polaritons" edited by E. Burstein and F. DeMartini (Plenum Press, N.Y., 1974).
7. F. DeMartini and Y. R. Shen, Phys. Rev. Lett. 36, 216 (1976).
8. F. DeMartini, G. Giuliani, P. Mataloni, E. Palange, and Y. R. Shen, Phys. Rev. Lett. 37, 440 (1976).
9. F. DeMartini, M. Colocci, S. E. Kohn, and Y. R. Shen, Phys. Rev. Lett. 38, 1223 (1977).
10. N. Bloembergen and P. S. Pershan, Phys. Rev. 128, 606 (1962).
11. See, for example, the lecture notes of Prof. S. A. Akhmanov in this



Summer School.

12. H. J. Simon, D. E. Mitchell, and J. G. Watson, Phys. Rev. Lett. 33, 1531 (1974); H. J. Simon, R. E. Benner, and J. G. Rako, Optics Comm. 23, 245 (1977).
13. F. DeMartini, F. E. Palange, P. Ristori, E. Santamato, A. Vena, A. Zammit, and Y. R. Shen, in Xth international Quantum Electronics Conference, Atlanta, Georgia, June, 1978, paper J.2.
14. V. M. Agranovitch, JETP Lett. 24, 558 (1976).

## Figure Captions

- Fig. 1 Schematical drawing showing a surface wave propagating on a plane surface. The intensity of the surface wave decays exponentially away from the surface.
- Fig. 2 Experimental setup. The inset shows the wavevector diagram for the four-wave mixing process.
- Fig. 3 Experimental results of normalized  $I(\omega_4, \Delta k_x)$  versus  $\Delta k_x$  at  $\omega = 370, 380, 390,$  and  $395 \text{ cm}^{-1}$  in GaP. The solid curves are Lorentzian used to fit the data points.
- Fig. 4 Measured dispersion characteristics of surface polaritons in GaP. ( $\circ$  —  $K'_x$  versus  $\omega$ ;  $\Delta$  —  $2K''_x$  versus  $\omega$ ). The solid curves are calculated from Eq. (5) using a single-oscillator model. The dashed curves are calculated from the multi-oscillator model of A. S. Barker, Phys. Rev. 165, 917 (1968).
- Fig. 5 Experimental results of normalized  $I(\omega, \Delta k_x)$  versus  $\Delta k_x$  at four output frequencies in ZnO. The solid curves are Lorentzian used to fit the data points.
- Fig. 6 Measured dispersion and damping characteristics of surface exciton-polariton in ZnO. ( $\circ$  —  $K'_x$  versus  $\omega$ ;  $+$  —  $K''_x$  versus  $\omega$ ). The solid curves are calculated from Eq. (11).

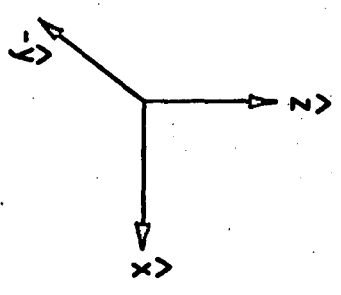
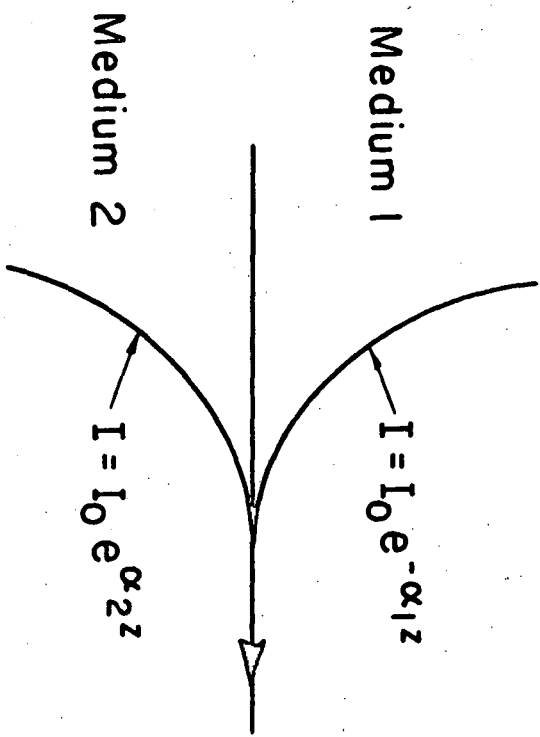

XBL 789-5817

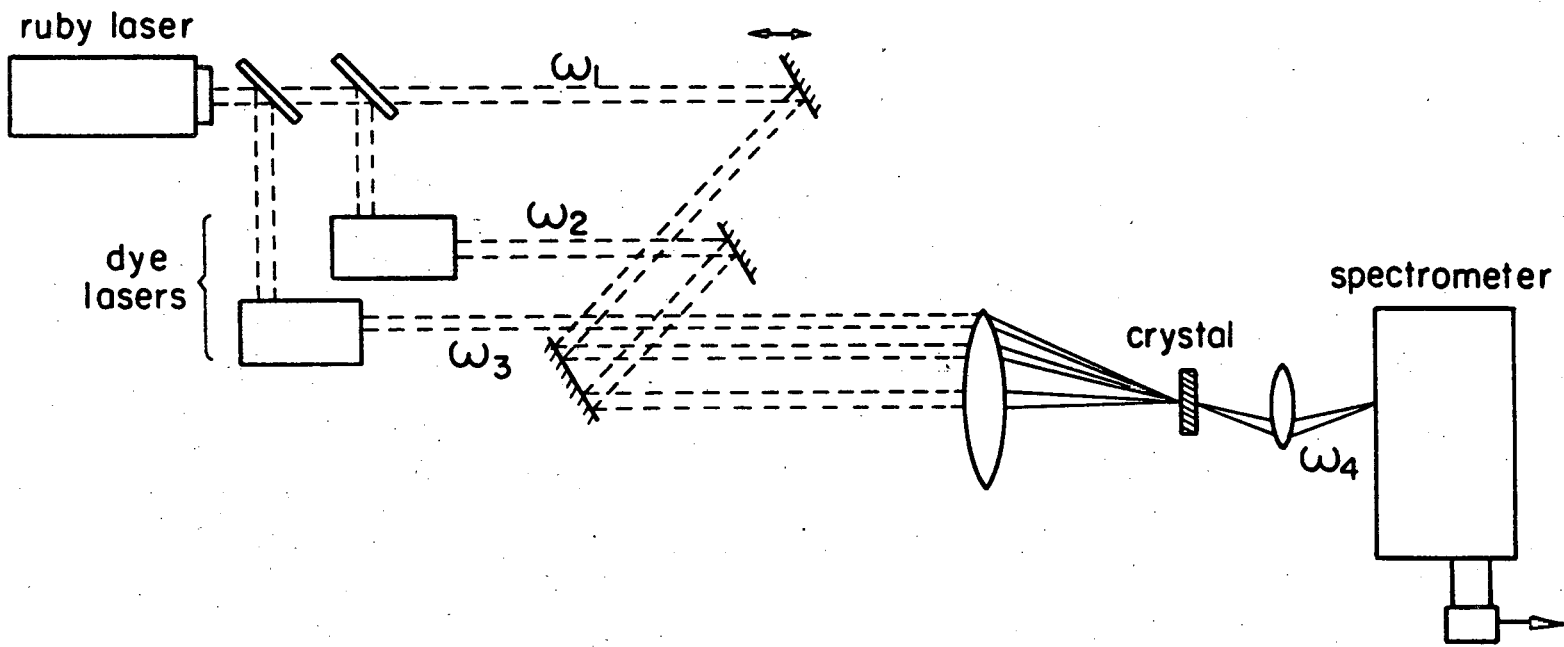
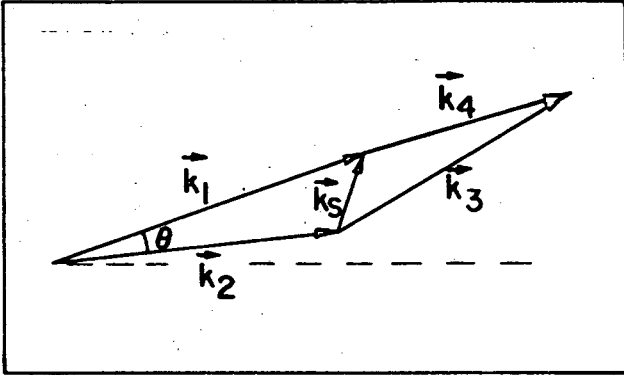

XBL 764-6740

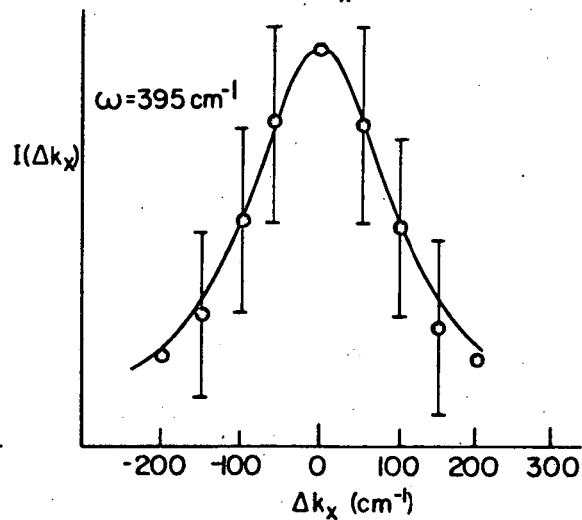
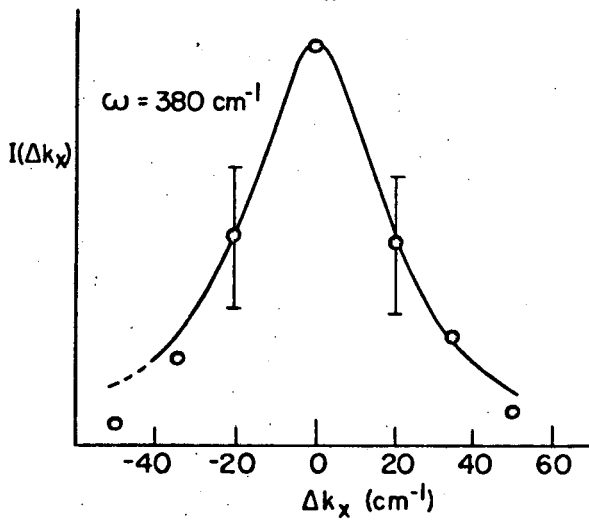
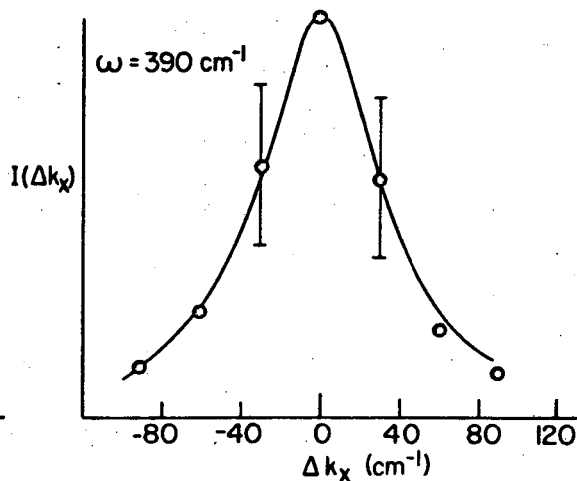
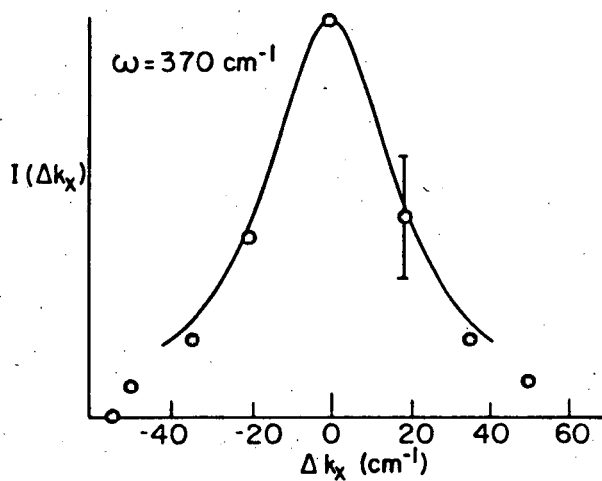

XBL 764 - 674I

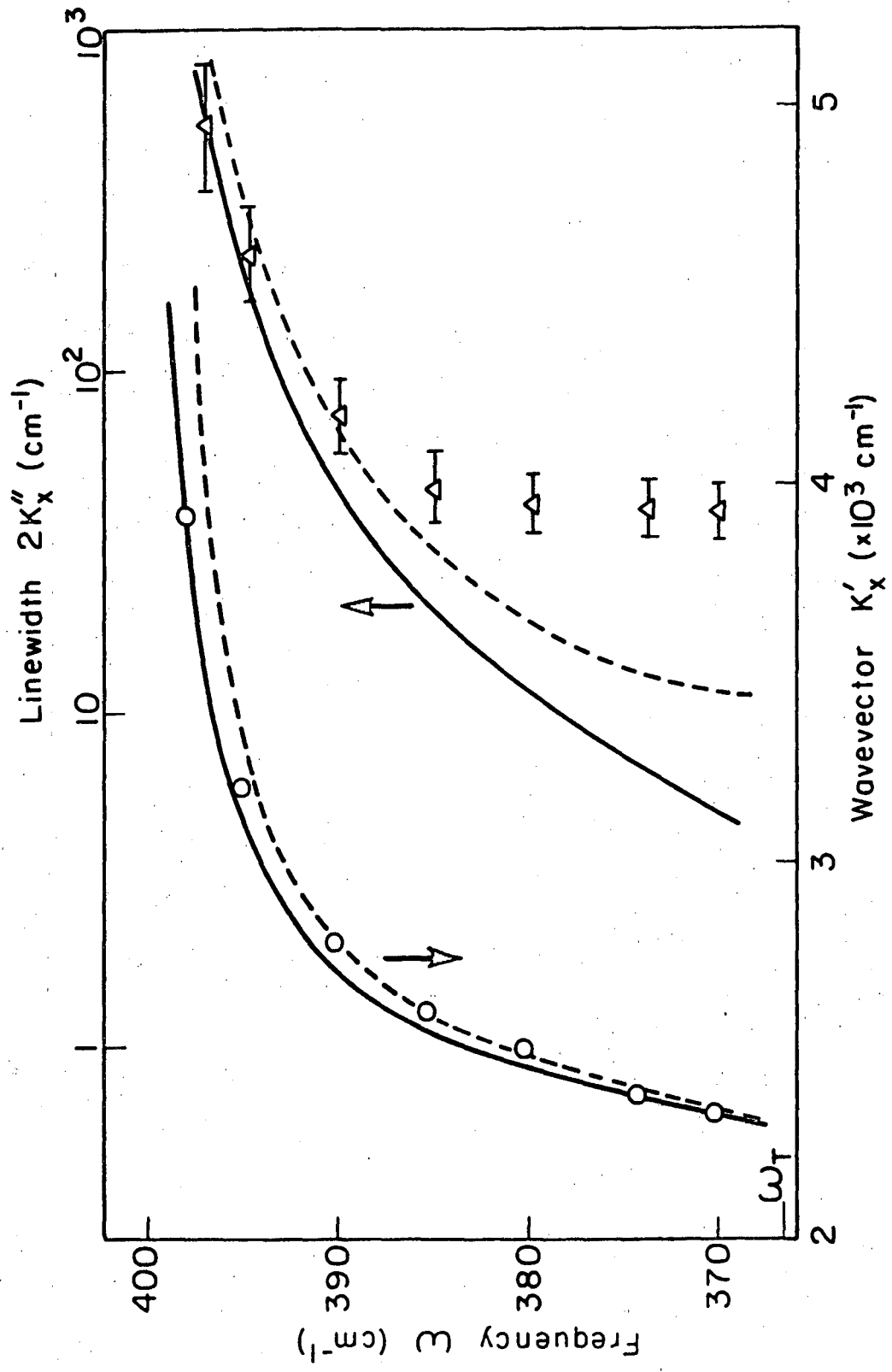

XBL 764- 6739

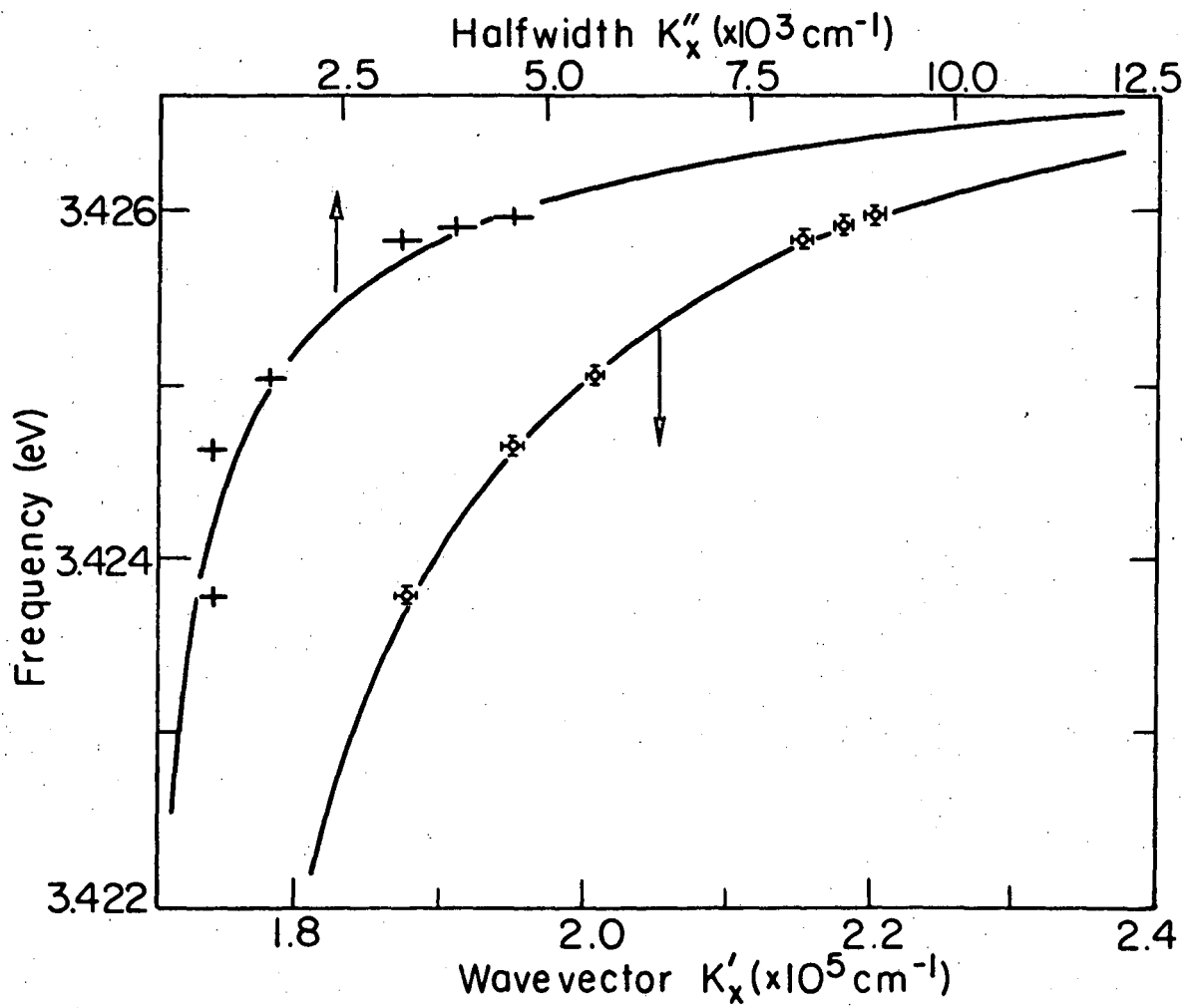

XBL772-5094

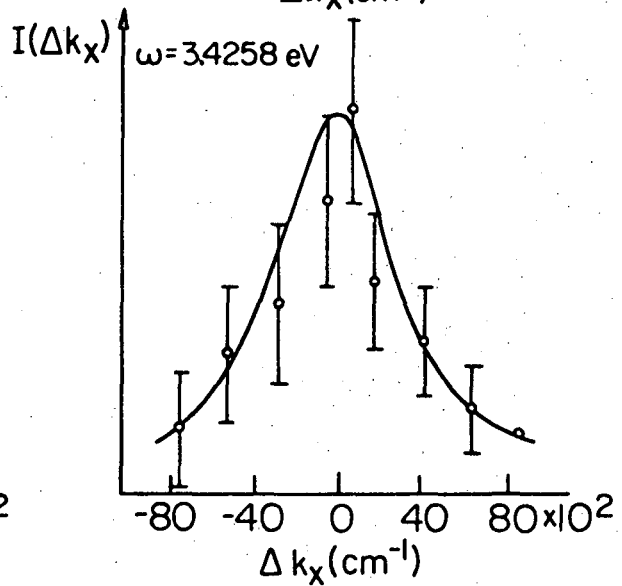
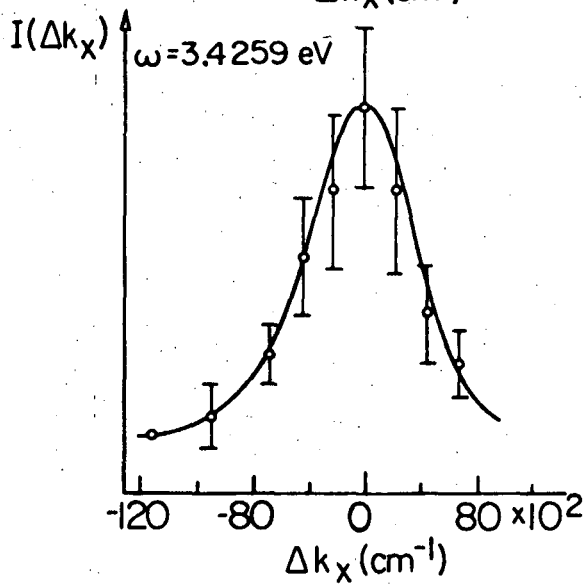
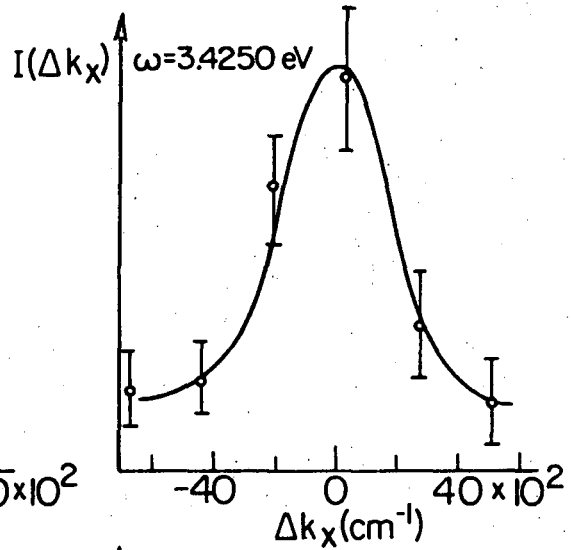
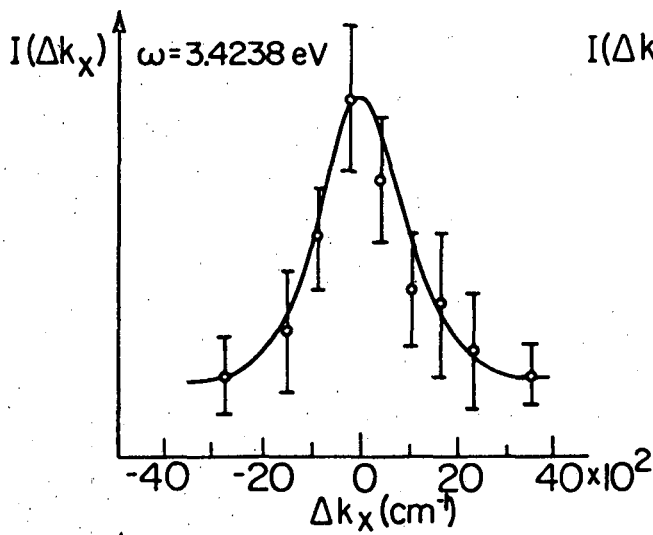

XBL 772-5093



This report was done with support from the Department of Energy. Any conclusions or opinions expressed in this report represent solely those of the author(s) and not necessarily those of The Regents of the University of California, the Lawrence Berkeley Laboratory or the Department of Energy.

TECHNICAL INFORMATION DEPARTMENT  
LAWRENCE BERKELEY LABORATORY  
UNIVERSITY OF CALIFORNIA  
BERKELEY, CALIFORNIA 94720