

# Lawrence Berkeley National Laboratory

## LBL Publications

### Title

Improved Delay Lines for Proportional Wire Chamber Readout

### Permalink

<https://escholarship.org/uc/item/3bb0b1b5>

### Authors

Grove, R

Perez-Mendez, V

Sperinde, J

### Publication Date

1972-08-01

Submitted to  
Nuclear Instruments and Methods  
as a Letter to the Editor

**RECEIVED** LBL-1035 Rev.  
LAWRENCE Preprint  
RADIATION LABORATORY

NOV 3 1972

LIBRARY AND  
DOCUMENTS SECTION

IMPROVED DELAY LINES FOR  
PROPORTIONAL WIRE CHAMBER READOUT

R. Grove, V. Perez-Mendez, and J. Sperinde

August 1972

AEC Contract No. W-7405-eng-48

**TWO-WEEK LOAN COPY**

This is a Library Circulating Copy  
which may be borrowed for two weeks.  
For a personal retention copy, call  
Tech. Info. Division, Ext. 5545



LBL-1035 Rev.

37

## **DISCLAIMER**

This document was prepared as an account of work sponsored by the United States Government. While this document is believed to contain correct information, neither the United States Government nor any agency thereof, nor the Regents of the University of California, nor any of their employees, makes any warranty, express or implied, or assumes any legal responsibility for the accuracy, completeness, or usefulness of any information, apparatus, product, or process disclosed, or represents that its use would not infringe privately owned rights. Reference herein to any specific commercial product, process, or service by its trade name, trademark, manufacturer, or otherwise, does not necessarily constitute or imply its endorsement, recommendation, or favoring by the United States Government or any agency thereof, or the Regents of the University of California. The views and opinions of authors expressed herein do not necessarily state or reflect those of the United States Government or any agency thereof or the Regents of the University of California.

IMPROVED DELAY LINES FOR PROPORTIONAL WIRE CHAMBER READOUT

R. Grove, V. Perez-Mendez, and J. Sperinde

Lawrence Berkeley Laboratory

Berkeley, California

August, 1972

ABSTRACT

Various modifications to the electromagnetic delay lines used for wire chamber readout are described. These consist of changing the cross-section of the lines, decreasing the eddy current losses, the dielectric losses, and increasing the characteristic impedance. The effect of these modifications is to increase the coupling efficiency to the chamber wires and to make the delay-to-risetime ratio equal to 30 for a 50-cm long delay line, with a total delay of 2.65 microseconds.

In previous papers<sup>1</sup> a readout scheme for multiwire proportional chambers using electromagnetic delay lines has been presented. This method has the advantage of being both simpler and cheaper than the amplifier array method as well as providing higher spatial resolution. The construction and electrical characteristics of phase-compensated distributed parameter electromagnetic delay lines suitable for use with

multiwire proportional chambers were also described.<sup>2</sup>

The changes in the design of the delay line described below were made in order to increase the coupling efficiency as well as to improve the high frequency response and thus obtain better two pulse resolution and less attenuation. The coupling efficiency is increased in two ways. First the line is made wider and thus the coupling capacity is increased. In addition, the delay line characteristic impedance has been increased by increasing the ratio  $L/C$  where  $L$  is the inductance per unit length and  $C$  is the capacitance per unit length. Since the coupling impedance and the delay line characteristic impedance behave as a voltage divider, the signal on the delay line will be increased by both of the above changes. Note that since the chambers are current limited sources further increases in the coupling capacity merely load the signals on the chambers producing at most about a 50% increase in the amplitude of the delay line output signal even in the case in which the chamber wires are directly coupled to the delay line.

The improvement in the higher frequency response was obtained as the result of several changes. First, the lines have been made thinner. This has the effect of decreasing the distance over which there is significant mutual inductance, thereby increasing the frequency at which inductance becomes dependent on frequency and dispersion becomes important. To keep the delay per unit length at the desired value of 50 - 100 ns/cm both the width of the line and the number of turns per cm of helical winding were increased. Eddy current losses in the distributed ground strip, the compensating pads, and the coupling pads can be reduced either by making the conducting strips less than 1 mm wide

or making them slightly resistive ( $\sim 1 \Omega/\text{sq}$ ). In the line described below, narrow strips were used for the distributed ground and the resistive material for the compensating pads. Finally, dielectric losses in the distributed capacitance of the delay line have been minimized by making the former of Nema G-7 (a glass-fibre plastic impregnated with low-loss silicone resin) and the dielectric spacer between the ground plane and the helical winding of Polyethylene.

The construction of the delay line is shown in fig. 1. The electrical characteristics are given in Table I along with the characteristics of an old line which are included for comparison.

Table I  
Mechanical and electrical parameters of the delay line.

Parameter	New	Old
Length	51 cm	57 cm
Width	3.2 cm	2.6 cm
Thickness	.33 cm	.9 cm
Windings (#38 wire)	78 turns/cm	34 turns/cm
Ground Strip Width	2.5 cm	3.4 cm
Compensation Strip Width ( $45^\circ$ )	$\approx 1$ cm	1.8 cm
Inductance	77 $\mu\text{h}/\text{cm}$	30 $\mu\text{h}/\text{cm}$
Capacity	36 pf/cm	49 pf/cm
Impedance	1500 $\Omega$	750 $\Omega$
Delay	52 ns/cm	39 ns/cm
Coupling Efficiency	18%	5%
Attenuation	5 db/m	6.5 db/m
Band pass	-3 db @ 3 MHz	-3db @ 2.5 MHz
Delay/Risetime	30:1	15:1
D.C. resistance	590 $\Omega$	300 $\Omega$

From the table, taking the delay-to-risetime ratio as a figure of merit, it is seen that the new line with a value of 30 is appreciably better in its overall frequency response than the previously described line. The coupling efficiency is now 18%, a substantial increase over the old line. Typical pulses from the delay line are seen in fig. 2a. Pulses showing the line response versus the two pulse separation are shown in fig. 2b.

We would like to thank Drs. Daniel Maeder and Sherwood Parker for contributing useful comments and suggestions.

This work was done under the auspices of the United States Atomic Energy Commission.

FIGURE CAPTIONS

Fig. 1. Details of rectangular cross-section delay line with floating patch phase-compensation.

Fig. 2. Response of delay line to simulated chamber inputs fed in capacitively. (a) Output pulse amplitude and shape as a function of distance of input pulse. (b) Output pulse shape as a function of distance between input pulses at 25 cm down the line.



REFERENCES

1. R. Grove, K. Lee, V. Perez-Mendez, and J. Sperinde, Nuc. Inst. & Methods 89 (1970) 257.
2. R. Grove, I. Ko, B. Leskovar, V. Perez-Mendez, Nuc. Inst. & Methods 99 (1972) 381.

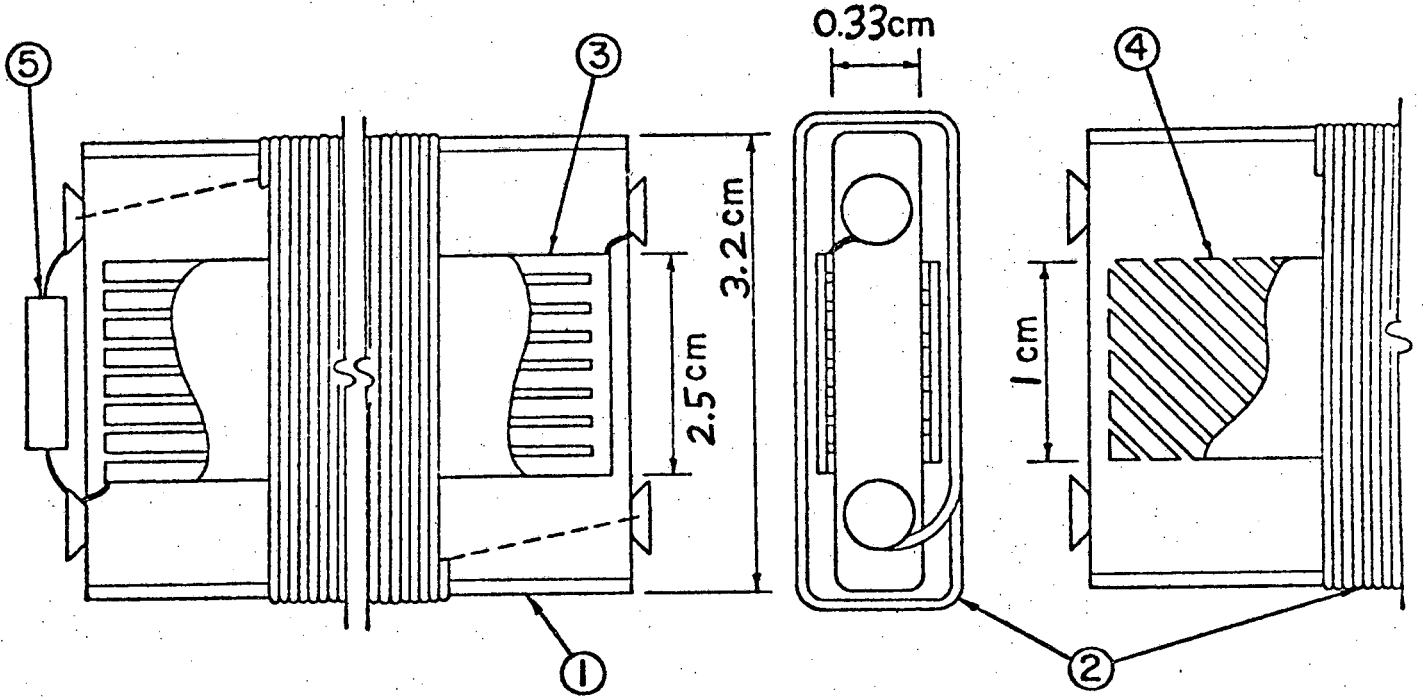

1. G-7 Fiberglas core (silicone resin binder).
2. Winding (#38 wire, 8 turns/mm).
3. Ground Strips (10 strips/cm of 25  $\mu$ m Cu. Strip width = 0.5 mm, gap width = 0.5 mm).
4. Compensating Strips (metalized strips on plastic).
5. Terminating Resistor.

Fig. 1

DELAY LINE PULSES

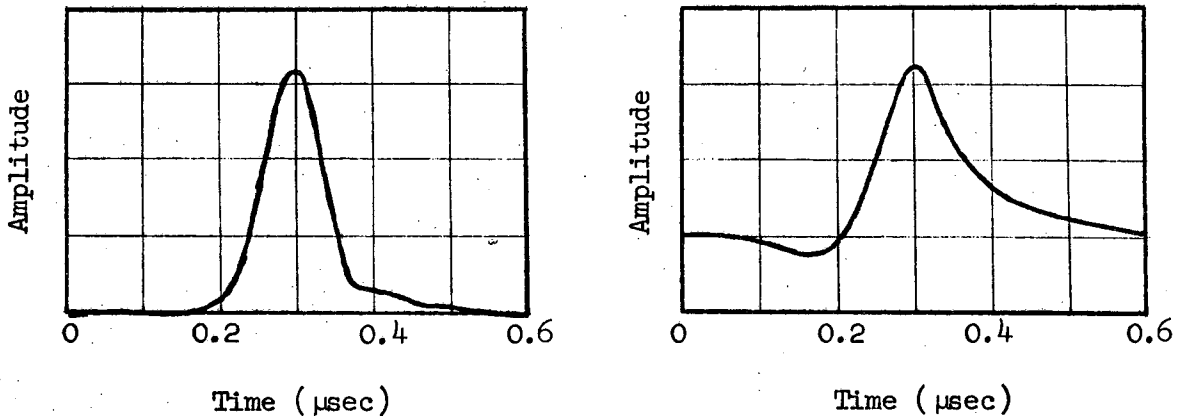

Output Pulses from Delay Line  
(10 cm down line)                      (40 cm down line)

Fig. 2a

DELAY LINE PULSES FOR TWO SIMULTANEOUS EQUAL-AMPLITUDE INPUT PULSES

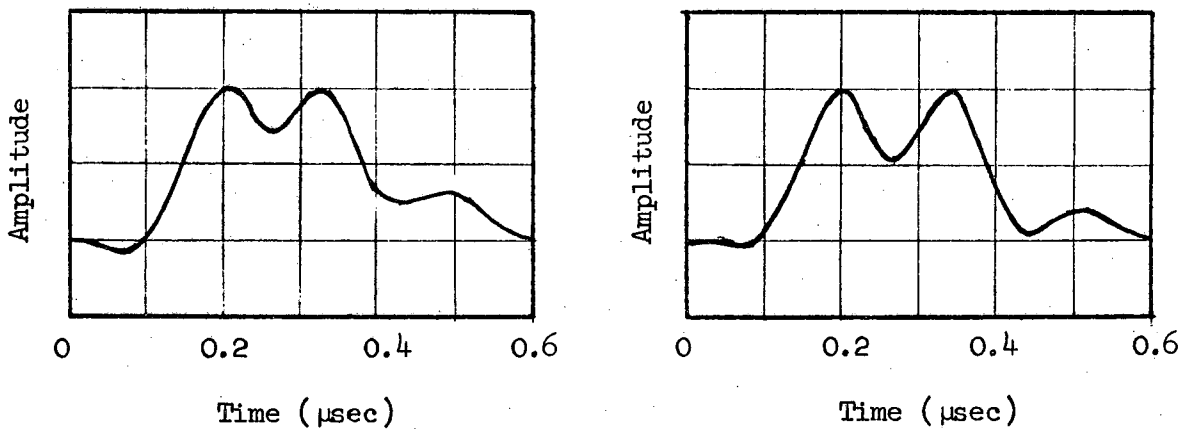

Input Pulse Separation

(2 cm)

(2.5 cm)

Fig. 2b

Submitted to  
Nuclear Instruments and Methods  
as a Letter to the Editor

LBL-1035 Rev.  
Preprint

IMPROVED DELAY LINES FOR  
PROPORTIONAL WIRE CHAMBER READOUT

R. Grove, V. Perez-Mendez, and J. Sperinde

August 1972

AEC Contract No. W-7405-eng-48



LBL-1035 Rev.