

Lawrence Berkeley National Laboratory

Recent Work

Title

RF Plasma source for a heavy ion fusion injector

Permalink

<https://escholarship.org/uc/item/3c50q8wb>

Authors

Westenskow, G.A.

Grote, D.P.

Halaxa, E.

et al.

Publication Date

2004-07-24

TH.P-12

RF PLASMA SOURCE FOR A HEAVY ION FUSION INJECTOR *

G.A. Westenskow, D.P Grote, E. Halaxa, Lawrence Livermore National Laboratory

J.W Kwan, W.L Waldron, Lawrence Berkeley National Laboratory

Abstract

We are developing high-current ion sources for Heavy Ion Fusion applications. Our proposed RF plasma source starts with an array of high current density mini-beamlets (of a few mA each at ~ 100 mA/cm²) that are kept separated from each other within a set of acceleration grids. After they have gained sufficient kinetic energy (>1.2 MeV), the mini-beamlets are allowed to merge together to form a high current beam (about 0.5 A) with low emittance. Simulations have been done to maximize the beam brightness within the physical constraints of the source.

We have performed a series of experiments on an RF plasma source. A 80-kV 20- μ s source has produced up to 5 mA of Ar⁺ in a single beamlet. We have measured the emittance of a beamlet, energy spread, and the fraction of ions in higher charge states. We have tested a 50-kV 61-hole multi-beamlet array. We are assembling a test of the extraction gap and first four Einzel Lens at the full gradient proposed for an injector. This experiment will produce a 0.3 A beam. We are constructing hardware for an experiment with merged beamlets. It will be tested at one-quarter the normal gradient proposed for a full injector. It should produce a low-emittance 56-mA beam.

TH.P-12;

PAC codes: (07.77.Ka Charged-particle beam sources and detectors)(41.85.Ar Beam extraction, beam injection)(29.27.Ac Beam injection and extraction)

Keywords: Ion Source, Particle Injector, Heavy Ion Fusion

Glen Westenskow; LLNL, L-645; PO Box 808, Livermore, CA 94551 , westenskow1@llnl.gov

I. BACKGROUND ON RF PLASMA SOURCE

Following a proposal that the usual limits on brightness for compact ion-beam sources used in Heavy Ion Fusion can be circumvented by using a multi-beamlet injector¹ we have started an experimental program to examine practical issues. The final source envisioned (see Fig. 1) will start with ~200 5-mA beamlets across a 100-kV gap. The beamlets will be focused by Einzel Lens while their energy is increased to about 1.2 MeV. The beamlets are then merged to produce a 1-A beam with a normalized 4*rms emittance of 1π -mm-mrad at 1.6 MeV.

Beyond providing a low-temperature source that can provide ion emission densities of ~100 mA/cm², the main physics issues involved in the multi-beamlet approach are emittance growth and envelope matching in the merging process. In computer simulations, if the initial emittance is in the range of measured values, the final emittance increases only a few percent due to the initial emittance of the individual beamlets[1].

II. STUDYING INDIVIDUAL BEAMLETS

We are using an rf plasma source to produce an argon ion beam. The plasma chamber has 26-cm inner diameter with multicusp permanent magnets to confine plasma (see Figure 2) . RF power (13 MHz) is applied to the source via a 2-turn, 11-cm diameter antenna inside the chamber for producing beam pulses of 20 μ s at up to 10 Hz. We have shown that we can extract 100 mA/cm² from the chamber (see Fig. 3). Optimum performance at 80 kV was achieved with ~2 mTorr gas in the plasma chamber and a 22 kW. At the lower gap potential of 50kV the best emittance (optics) was achieved with a 12 kW drive.

Our first step was to characterize the current in a single beamlet from the rf plasma source. We believe that the “roll-over” in Fig. 3 occurred when ions were lost during transport to the cup.

Increasing the source pressure above 2 mTorr continued to increase the ion density in the chamber, but did not yield higher extracted currents from the gap. Increasing the source pressure will also increase the charge exchange in the gap. Current density was found to increase with RF power in the source as long as there was sufficient extraction voltage. At 80 kV, we have reached our goal of producing 100 mA/cm² of Ar⁺ ions (i.e. 4.9 mA per beamlet). At drive powers higher than 10 kW, we estimated that less than 5% of the extracted ions were in the Ar⁺⁺ state.

We used a narrow slit and a slit cup to examine the $x - x'$ phase space of a beamlet. An example is shown in Fig. 4. The normalized emittance for the beamlet was about 0.02π -mm-mrad. The emittance is minimized when the source current density matched the space charge limit. At the optimum condition, the normalized emittance (measured by a double-slit scanner) of 0.0186π -mm-mrad has an equivalent ion temperature of about 2.0 eV.

An early concern was that collisions between the extracted ions and the background gas would yield an excessive amount of charge exchange. The newly created ions would leave the gap with lower energies and different transverse motion. At 2 mTorr source pressure, the amount of this component is < 0.3% of the full energy component and was spread over a range of 2 keV below the full energy [2].

Additional details about the rf plasma source have been published [2,3].

III. MULTI-BEAMLET EXPERIMENTS

We have tested a multi-beamlet extraction array. The bottom beam-forming plate shown in Fig. 2 has Pierce Cones for each of the beamlets. The apertures in the bottom plate are 2.2 mm diameter. The holes in the top plate are 4.0 mm diameter.

The plate shown in Fig. 2 are held with three High-Gradient Insulators. At 50 kV across the 1.6 cm gap they would occasionally flash over, but usually recondition rapidly. Individually they would hold 80

kV DC potential without beam. A conservative working voltage is about 40 kV/cm for a 20- μ sec pulse in the gap environment.

Figure 5 shows the change in the opacity of a kapton sheet hit with 50-kV 20- μ s beamlets from the array. The kapton sheet was 2 cm from the extraction plate.

An Einzel Lens (shown in Fig. 6) was added to the extraction gap. In the Full-Gradient and the Merge Experiments the lens will be used to also boost the energy of the beamlets. We separated the lens with high-gradient insulators. The separation of the lens was about 1 cm.

We tested the 61-hole multi-beamlet array up to about 50 kV. Merging of the beamlets was not done at this stage because the perveance is too high. Also, minimizing the final transverse phase space will require curved plates for the Einzel Lens.

IV. FULL GRADIENT EXPERIMENT

The Full-Gradient Experiment (see Fig. 7) was designed to test our ability to hold electrical fields in the working environment of the RF Plasma source. The dimensions and electric fields are typical of what we would like to use in an actual injector. Since we are limited to about 400-kV of pulsed voltage, we are only going to test the first 5 gaps of a full system (see Fig. 8 and 9). To reduce the cost we did not use curved plates that we feel are essential in an actual injector to achieve a high quality merged beam.

There is gas streaming through the extraction holes at beam time. The gas pressure in the Plasma Chamber will be about 2 mTorr at beam time. The gas is introduced into the chamber about 100 msec before beam time. As the number of beamlets increases there will be less differential pumping between the chamber and the lens. The voltage pulse length (>90% level) is 17 μ sec in duration. There will be some beam spill on the plates from the halo particle.

The highest vacuum electric field gradient occurs between the 336-kV plate and the 208-kV plate (shown in Fig. 8), and is 100 kV/cm on axis. This gap is 1.2 cm. Fields at the edge of the holes are expected to be about 120 kV/cm for this gap. The gradient along the insulators is 30 kV/cm. The insulators between cups are either 4.27 cm or 2.13 cm. We have used HGI at up to 50 kV/cm. Achieving these gradients is expected to require conditioning of the surfaces. There are 2-k Ω resistors between the column voltage tapoffs and the plates to limit energy that would be dumped into an electrical arc if it occurs between the plates.

The current per beamlet is 3.8 mA at an extraction current density of 100 mA/cm². There are 61 beamlets for a total current of 232 mA. We plan to measure the total current, and acquire images of the beamlets, but will not measure other characteristics of the total beam. The field direction in the fourth gap is reversed to help focus the beamlets.

V. MERGING EXPERIMENT

For a proof-of-principle test of the merging process, we have designed an experiment at full dimensions but which will operate at one-quarter the voltage of an actual injector. Since all the voltages in this electrostatic system are reduced by the same factor, and the current density is scaled according to the “three-half” space charge limited condition, the beam optics of merging remains unchanged. A layout is shown in Fig. 10. The concept of merging beams is presented elsewhere in these proceedings[2]. There is an extraction plate and 10 lens plates in the experiment. Figure 11 shows a sample plate in the lens assembly. Because the voltages between plates is reduced by factor of four, we did not design reentrant cups, as in the Full-Gradient Experiment (see Fig. 9), to hold the lens. We can use HGI directly between the plates to hold the assemble together.

The emittance growth (normalized to a constant beam current) is minimized when the beamlet energy is high (at the time of merging), the number of beamlets is large, and the beamlets are close to each others. The final emittance depends on the initial beamlet convergent angle and weakly on the ion temperature[1]. Figure 12 shows the evolution of 91 beamlets in configuration space. The x and y rms emittance was found to initially rise to different values because of the elliptical shape but later came to an equilibrium value (average between x and y emittance) in about 10 m distance

VI. ACKNOWLEDGEMENT

We would like to thank Gary Freeze, Robert Hall, and Jon Kapica for their assistance with the experiments.

VII. REFERENCES

- [1] D.P. Grote, E. Henestroza, J.W. Kwan, *PRST Accelerators and Beams* **6**, 014202 (2003).
- [2] J.W. Kwan, et al., “Ion Source and Injector Experiments at the HIF/VNL” in these proceedings.
- [3.] G.A. Westenskow, et al., “High Current Ion Source Development for Heavy Ion Fusion”, to be published in the proceedings The Third International Conference on Inertial Fusion Sciences and Applications (IFSA2003), Monterey, California, September 7-12, 2003.

.
*This work has been performed under the auspices of the US DOE by UC-LBNL under contract DE-AC03-76SF00098 and by UC-LLNL under contract W-7405-ENG-48, for the Heavy Ion Fusion Virtual National Laboratory.

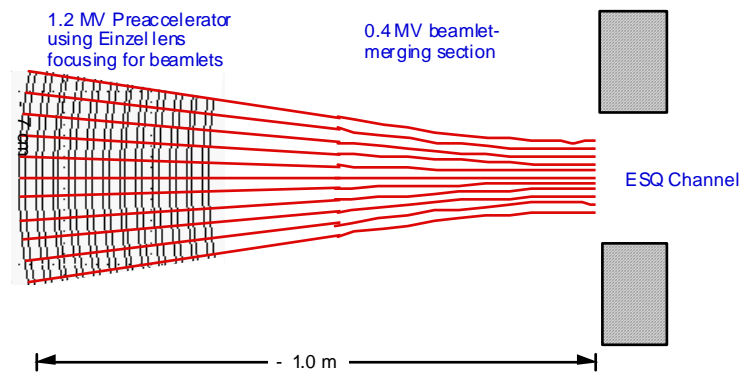

Fig. 1. Layout for the full injector using merging.

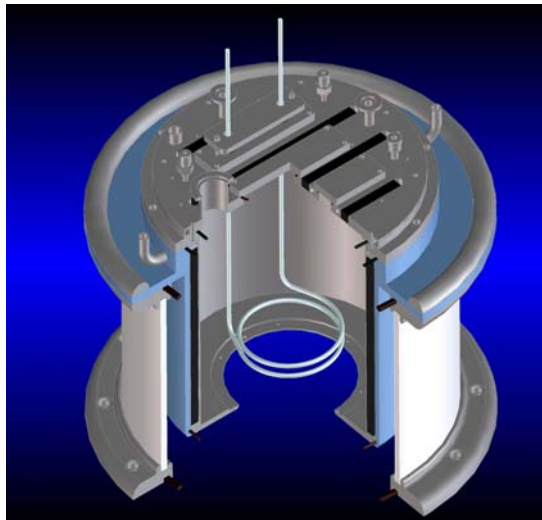

Fig. 2. RF multicusp source and Einzel lens to produce 61 high current density beamlets.

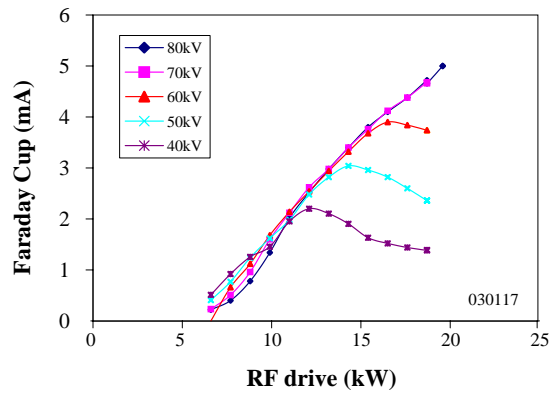

Fig. 3. Current detected at the Faraday Cup for a single beamlet at 2-mTorr source pressure. The source aperture was 2.5 mm diameter. The curves are at different extraction-gap potentials.

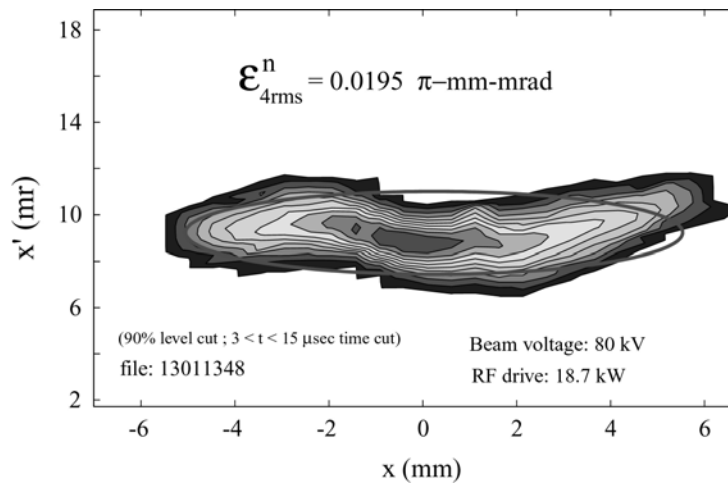

Fig. 4. Transformed phase space of the beamlet shown in the previous figure.

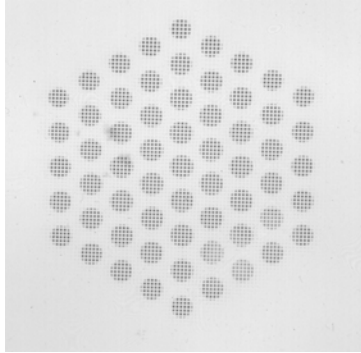

Fig. 5. Image of 61 beamlets on a Kapton sheet. The fine lines on the beam spots are due the presence of a mesh in front of the Kapton to neutralize the deposited beam charge.

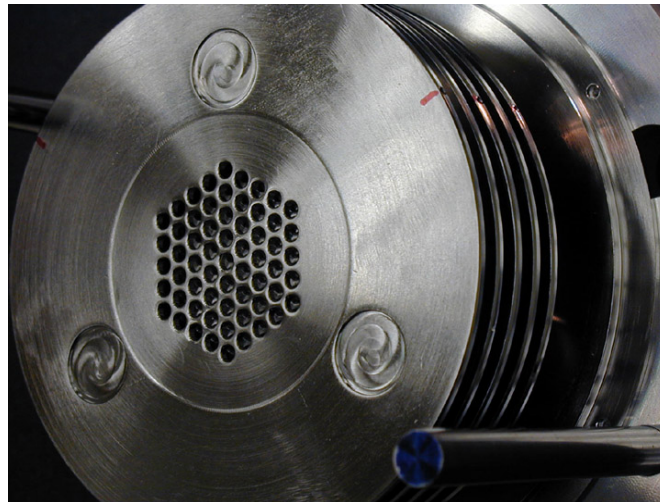

Fig. 6 Einzel Lens installed on the 61 hole extraction array. The distance between top and bottom beamlet hole is 5.2 mm.

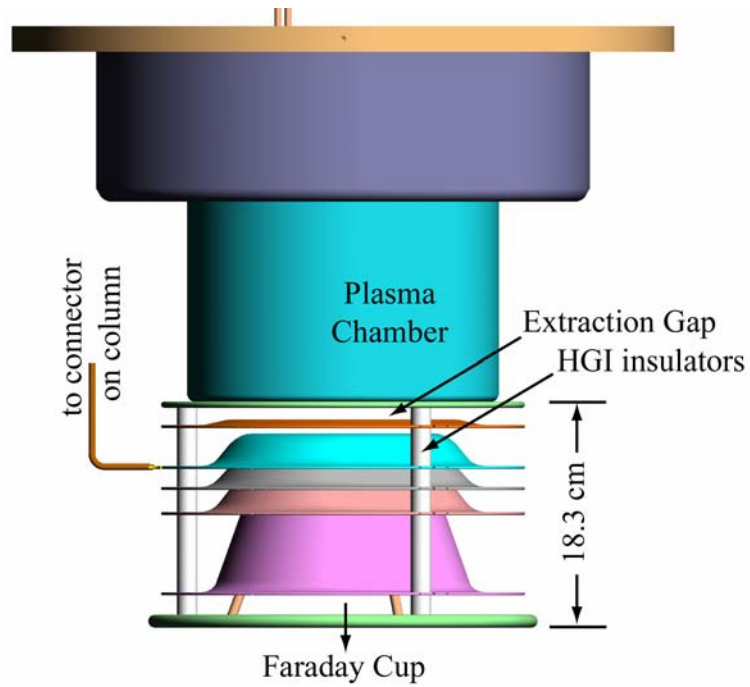

Fig. 7. Layout for the Full-Gradient Experiment.

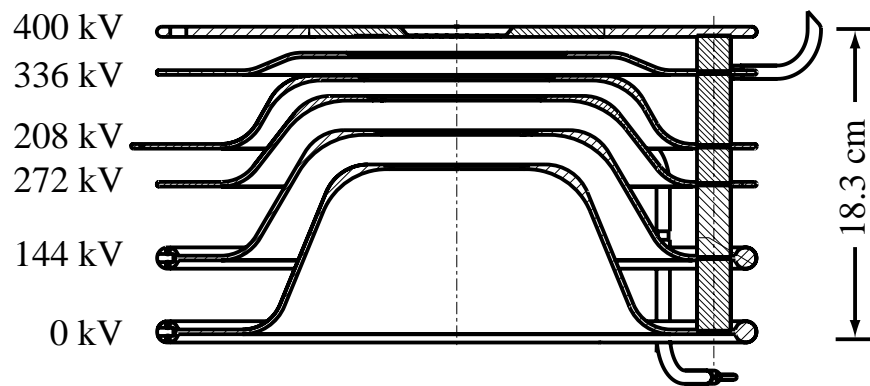

Fig. 8. Layout of the plates in the Full-Gradient Experiment.



Fig. 9 Last reentrant cup in the Einzel Lens assembly before it was assembled into the stack.

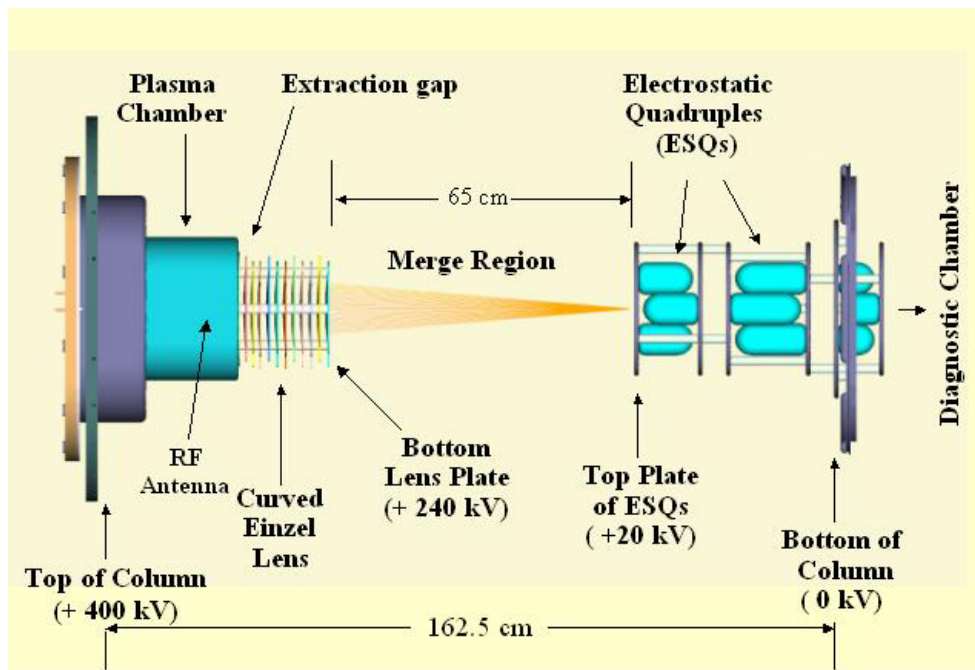

Fig. 10. Layout of the Merge Experiment.

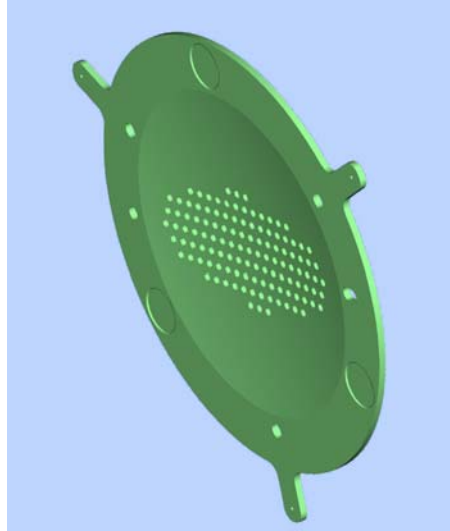

Fig. 11. One of the lens plates used in the assemble. The curvature of the plate is about 60 cm. There are 119 holes for the beamlets, with about 6 mm between holes. The plate's outer diameter is 20 cm. The plates of Stainless Steel.

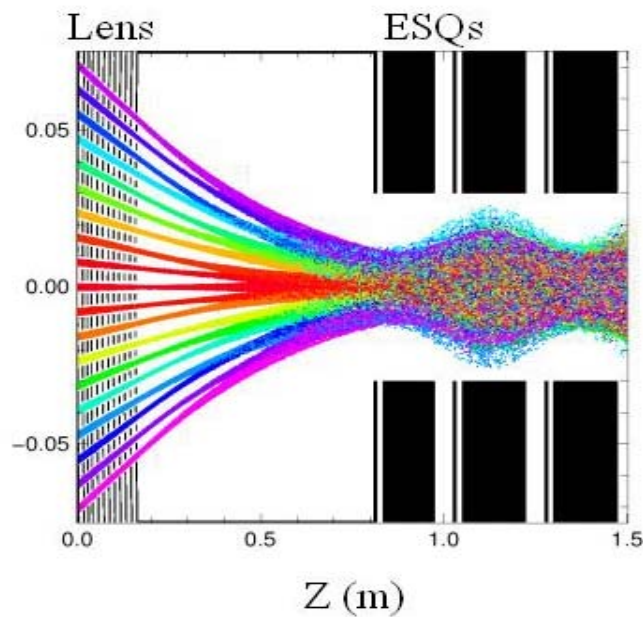

Fig. 12. Simulation showing mixing of the beamlets in the Merge and ESQs Regions. View is from the top of previous figure.