

# UC Berkeley

## Planning & Evaluation

### Title

Achieving More With Less: Efficiency and Economics of Motor Tools

### Permalink

<https://escholarship.org/uc/item/3c82x7pz>

### Authors

Agamloh, Emanuel  
Butler, Kitt  
Kaufman, Nicole  
[et al.](#)

### Publication Date

2006-03-22

Achieving More  
with Less:  
Efficiency and  
Economics of Motor  
Decision Tools [2006]

| PREPARED BY ADVANCED ENERGY |



909 Capability Drive, Suite 2100 | Raleigh, NC 27606-3870  
919-857-9000 | [www.advancedenergy.org](http://www.advancedenergy.org)

**PROJECT TITLE**

Achieving More with Less: Efficiency and Economics of Motor Decision Tools  
Solicitation 03-STAC-01

**COVERING PERIOD**

October 1, 2003, to March 22, 2006

**DATE OF REPORT**

March 22, 2006

**RECIPIENT ORGANIZATION**

Advanced Energy

**PARTNERS**

Washington State University Energy Program  
California Energy Commission  
New York State Energy Research and Development Authority

**TECHNICAL CONTACT**

Daniel Welch, P.E.  
Advanced Energy  
909 Capability Drive, Suite 2100 | Raleigh, NC 27606  
919-857-9007 | Fax: 919-832-2696  
[dwelch@advancedenergy.org](mailto:dwelch@advancedenergy.org)

**BUSINESS CONTACT**

Maggy Inman  
Advanced Energy  
909 Capability Drive, Suite 2100 | Raleigh, NC 27606  
919-857-9004 | Fax: 919-832-2696  
[minman@advancedenergy.org](mailto:minman@advancedenergy.org)

## **AUTHORS**

*Advanced Energy*

Emanuel Agamloh

Kitt Butler

Nicole Kaufman

Ziba Kellum

Jeremy Morrison

Dan Welch

## **CONTRIBUTORS**

*Advanced Energy*

Sharon Gladwell

Camden Watts

Maribeth Weakland

Michelle Zahn

# Table of Contents

Preface .....	5
Executive Summary.....	8
Abstract .....	11
Introduction.....	12
Project Approach.....	13
Project Outcomes .....	14
Phase I: 100 Motor Study .....	16
Phase II: Economics of Motor Reliability .....	35
Phase III: Horsepower Breakpoint Curve Update.....	45
Phase IV: Dissemination of Results.....	55
Conclusions and Recommendations .....	59
References .....	60
Appendices.....	63

# Preface

This project report presents for the first time measured efficiency data from a population of older motors in industry. The project also presents load data collected from these motors that will be useful in projecting the savings to be gained from future motor energy conservation efforts.

Also included is informative work projecting the life-cycle benefits of improved motor reliability. Although an approach for projecting life-cycle benefits of reliability is presented, the baseline data is apparently not available in the public domain.

What is most striking about the work in both motor efficiency and reliability is the lack of data available to make important decisions in industry. We hope that this report will add to the body of knowledge and inspire others to collect the essential data that is needed to enable industry to make these critical decisions.

This publication also introduces a new simplified tool for producing customized horsepower breakpoint curves. This tool is now online and available at

*[www.advancedenergy.org/motors\\_and\\_drives/horsepower\\_breakpoint/tool](http://www.advancedenergy.org/motors_and_drives/horsepower_breakpoint/tool)*

Advanced Energy, located in Raleigh, N.C., submitted this report as the project lead.

Advanced Energy is a state-chartered institution, member of ASERTTI and affiliate member of NASEO. Also contributing to this project and report was the Washington State University (WSU) Cooperative Extension Energy Program, which has contributed to the literature search and field research. The California Energy Commission (CEC) and the New York State Energy Research and Development Authority (NYSERDA) have also participated financially and with in-kind assistance.

A key strength of this project has been partnerships with four states: California, New York, North Carolina and Washington. Advanced Energy, the project primary lead proposer, has been a leader in the motor industry for more than 20 years, and operates the nation's only independent accredited motor test laboratory. Also a leader in the motor industry, WSU has vast experience in motor systems research and training. It also operates the U.S. Department of Energy's (DOE) Industrial Technologies Program information hotline and maintains one of the few technical libraries for industry. Advanced Energy and WSU have formed a partnership to create the Motor Resource Center (MRC). Merging the skills and abilities of both organizations, the MRC provides a wide range of motor services.

In addition to the primary proposers mentioned above, this project has included a broad range of government and private partners. The California Energy Commission and the New York State Energy Research and Development Authority have each participated in the program,

providing both in-kind and cash contributions. A number of motor manufacturers, including Emerson, Reliance, Toshiba, WEG, TECO-Westinghouse, Regal-Beloit and General Electric, have provided in-kind assistance by discounting their NEMA Premium™ motors for replacing motors removed for testing.

This mix of public and private partnerships demonstrates value of the project for all parties involved. Improving energy efficiency, reducing electricity demand, increasing profitability and increasing reliability are all goals of this project.

#### NASEO Members

Washington State University Energy Program

California Energy Commission

New York State Energy Research and Development Authority

Advanced Energy [affiliate member]

#### ASERTTI Members

Advanced Energy

Washington State University Energy Program

California Energy Commission

New York State Energy Research and Development Authority

#### Other Partners

Brithinee Electric

Emerson Motor Technologies

General Electric

Regal-Beloit Corporation

Rockwell Automation Reliance Electric

TECO-Westinghouse Motor Company

WEG Electric Motors

Toshiba Industrial Division

This project has also garnered broad support from a wide range of industry and energy efficiency organizations, including the National Electrical Manufacturers Association (NEMA), the Consortium for Energy Efficiency (the *Motor Decisions Matter* campaign), the American Council for an Energy Efficient Economy (ACEEE), the Motor Resource Center (MRC)

Advisory Group and Applied Proactive Technologies, which oversees New England's MotorUp Premium Efficiency Motor Initiative and NYSERDA's Premium-Efficiency Motors Program.

We wish to acknowledge all project participants and thank them for their support and guidance.



# Executive Summary

## “Achieving More with Less: Efficiency and Economics of Motor Decision Tools”

### Project Objectives

Broadly stated, the objective of the project has been to make the U.S. motor stock as energy efficient and reliable as possible. Accomplishing this will appreciably impact the nation's energy consumption and make the nation's manufacturing more competitive. Our original hypothesis was that there may be much greater economic justification for replacement of old motors with the newer, high efficiency motors available today than the current motor decision tools indicate. Specifically, the objectives of this project were to:

1. Replace the anecdotal estimates of energy consumption of existing motors used for virtually all motor calculation software with fact-based data.
2. Obtain in-plant, historical data for the purpose of estimating the economic impact of reliability differences between new motors and older, rewind motors. Reliability is the most important consideration in motor repair versus replace decisions, but motor users currently do not have fact-based information in this area.
3. Update the horsepower breakpoint curves as distributed in the DOE *Horsepower Bulletin*, the industry's most widely used motor decision tool. Incorporate the results of the baseline studies into these curves.
4. Provide data for more accurate default efficiency numbers on existing motors for future revisions of MotorMaster+ and IMSSA.
5. Disseminate the results of these studies as widely as possible to have the greatest impact on motor management decisions and to foster regional revitalization through reduced energy costs and increased motor reliability.

### Major Findings and Outcomes

The results of this study show:

1. Motors in the field appear to operate below their nameplates and below the projections of many of the standard motor decision tools. The differences were appreciable; however, due to the high variance in the data and the small number of data points, they are not statistically significant and should be used with caution.
2. MotorMaster+ 4.0 provides relatively accurate efficiency information for evaluating the economics of motor repair versus replace decisions when operating at rated load (full load).

At the actual operating load conditions found in the field, MotorMaster+ 4.0 was found to over-estimate annual energy cost savings by 5.8 percent. Using the nominal efficiency to calculate annual energy savings provides an even closer estimate of annual dollar savings, over-estimating by 4.5 percent.

3. Many motors appear to be dramatically oversized or under loaded, indicating opportunities to improve allocation of capital to incur appreciable efficiency penalties. Nearly thirty percent of the motors were found to be operating below 50 percent load.
4. Efficiency testing of 20 NEMA Premium™ motors was conducted as an unfunded addition to the scope of work. These test data indicate that the NEMA Premium™ motors meet their stated nameplate efficiencies with statistical certainty as a sample, although some motors tested below the EPCA minimum efficiency.
5. The study verified that the NEMA Premium™ motors generally maintain a flatter efficiency curve as the motor load is reduced. That is, they maintain their efficiency better at lower loads.
6. NEMA Premium™ motors installed as part of this project are now saving an estimated 3.19 GBTU per year or 934 MWh per year. This will result in savings of \$39,423 per year for California participants, \$29,591 per year for New York participants and \$41,121 per year for North Carolina participants.
7. Motor reliability appears to have a great impact on the life-cycle cost of motor operations. The meager preliminary data available under this project suggest that the value of motor reliability may be far greater than the value of energy efficiency, and that motor reliability alone may justify the selection of a new motor versus rewinding.
8. A simplified method for producing customized horsepower breakpoint curves was developed as part of this project and is available at:  
[www.advancedenergy.org/motors\\_and\\_drives/horespower\\_breakpoint/tool](http://www.advancedenergy.org/motors_and_drives/horespower_breakpoint/tool)

## Project Recommendations

1. Continue to use the standard motor management tools, such as MotorMaster+ 4.0, to estimate motor efficiency benefits with caution recognizing overestimated savings until a revision is made to the software.
2. If facilities are not using the more involved motor decision tools, such as MotorMaster+ 4.0, they should use the simplified online tool for horsepower breakpoint curves to customize curves for their location to guide their repair versus replace decisions. The tool is located at: [www.advancedenergy.org/motors\\_and\\_drives/horespower\\_breakpoint/tool](http://www.advancedenergy.org/motors_and_drives/horespower_breakpoint/tool)
3. Use life-cycle cost methods to estimate reliability improvements for new versus rewind motors, *if that data is available*. We found that information is generally not available.
4. Facilities should track mean time between failures (MTBF) and the root cause of motor failures. This should become part of standard motor management practice. In future years, this data can provide justification for motor purchase decisions that will allow industry to reduce life-cycle operating costs.
5. The DOE or public energy efficiency advocacy agencies should encourage the tracking of MTBF data. If these data support the benefits of replacing failed motors with new motors, that may help transform the existing motor population to newer, higher efficiency motors. Since current practice is to rewind virtually all larger motors, and these larger motors use a disproportionate share of the energy, the potential impact of MTBF tracking is immense.

# Abstract

Approximately 70 percent of industrial electricity is used to power electric motors. Recent studies show that there is still tremendous energy-saving potential in converting to new, higher efficiency motors. The objective of this project was to provide fact-based information that has the potential to significantly affect motor choices in U.S. industry. The methodology of this project was to conduct analysis and testing in two areas: energy efficiency of in-service motors and the reliability of new versus repaired motors.

The project involved partners from four states: California, New York, North Carolina and Washington. Advanced Energy, the primary proposer, has been a leader in the motor industry for more than 20 years and operates the only independent, NIST-accredited motor test laboratory in the United States. The Washington State University Energy Program has also been a leader in the motor industry for more than a decade. Project partners also include the California Energy Commission and the New York State Energy Research and Development Authority (NYSERDA). Strong support came from a number of motor manufacturers, who have provided in-kind support exceeding 40 percent of the total project cost. The project also has had the support of a wide range of other parties, including the National Electrical Manufacturers Association (NEMA), the Consortium for Energy Efficiency (CEE) and its *Motor Decisions Matter* campaign, the Copper Development Association and the American Council for an Energy Efficient Economy (ACEEE).

This project has provided the first fact-based information for estimating motor efficiency in older motor populations. It verified that many of the assumptions are reasonably accurate and should continue to be used. It also demonstrated that motor reliability should be more strongly considered in the repair versus replace decision, but points out that data to support these decisions is extremely weak. One of the major recommendations is that motor users and industry advocates should be doing a better job of collecting data on motor reliability (the mean time between failures) of their motor populations.

## Introduction

A key market barrier to improving motor system efficiency is the absence of hard data to support the benefits of change. With hard data, the economics of the repair versus replace decision could change significantly. This could justify further penetration of NEMA Premium™ motors with a broad geographic impact, appreciatively boosting the efficiency of the industrial motor population, lowering production costs and improving industrial competitiveness. It will also reduce the environmental impact of energy generation and the national insecurity resulting from imported energy resources.

Nadel et al (2002) indicate potential savings of 79 TWH per year for increased use of the Energy Policy and Conservation Act (EPCA) level and NEMA Premium™ integral horsepower motors. This project sought to provide information to make the economic case for broad replacement of older, inefficient motors. If the results can help achieve just half of this potential, the impact would be a reduction of approximately 40 TWH per year. This is equivalent to about seven 1,000 MW power plants, about 35 million tons of coal per year or about 100 million barrels of oil per year.

There is also a very immediate impact from the 100 NEMA Premium™ motors that were installed as a direct result of this project. These motors should save 881 megawatt-hours per year and more than \$59,000 per year for those companies participating in this study.

Because motors are considered by many to be the largest of all cross-cutting technologies in industry, they provide great opportunities for energy savings. On average, industries consume 70 percent of their total electrical energy through motors, and that number may even be higher for the three Standard Industrial Classification (SIC) codes targeted by this proposal and solicitation.

# Project Approach

This project consisted of four phases with a different approach for each:

## **Phase I — 100 Motor Study**

In exchange for old, in-service motors, facilities were offered free, new NEMA Premium™ motors. Old motors were shipped to Advanced Energy's accredited lab for testing.

## **Phase II — Economics of Motor Reliability**

Reliability data from user tracking was sought to enable estimation of reliability (mean time between failures) of new motors versus older, rewound motors.

## **Phase III — Horsepower Breakpoint Curve Update**

The intent was to update the horsepower breakpoint curves with the new data from this project and make them more site specific and user friendly.

## **Phase IV — Dissemination of Results**

Presentations and publications have been made and will continue to be made in a number of industry venues.

More detail on the approach for each phase is provided in their respective report section.

# Project

## Outcomes

Results of this study show:

1. Motors in the field appear to operate below their nameplates and below the projections of many of the standard motor decision tools. The differences were appreciable; however, due to the high variance in the data and the small number of data points, they are not statistically significant and should be used with caution.
2. MotorMaster+ 4.0 provides relatively accurate efficiency information for evaluating the economics of motor repair versus replace decisions when operating at rated load (full load). At the actual operating load conditions found in the field, MotorMaster+ 4.0 was found to over-estimate annual energy cost savings by 5.8 percent. Using the nominal efficiency to calculate annual energy savings provides an even closer estimate of annual dollar savings, over-estimating by only 4.5 percent.
3. Many motors appear to be dramatically oversized or under-loaded, indicating opportunities to improve allocation of capital to incur appreciable efficiency penalties. Nearly thirty percent of the motors were found to be operating below 50 percent load.
4. Efficiency testing of 20 NEMA Premium™ motors was conducted as an unfunded addition to the scope of work. These test data indicate that the NEMA Premium™ motors meet their stated nameplate efficiencies with statistical certainty as a sample, although some motors tested below the EPCA minimum efficiency.
5. The study verified that the NEMA Premium™ motors generally maintain a flatter efficiency curve as the motor load is reduced. That is, they maintain their efficiency better at lower loads.
6. NEMA Premium™ motors installed as part of this project are now saving an estimated 3.19 GBTU per year or 934 MWh per year. This will result in savings of \$39,423 per year for California participants, \$29,591 per year for New York participants and \$41,121 per year for North Carolina participants.
7. Motor reliability appears to have a great impact on the life-cycle cost of motor operations. The meager preliminary data available under this project suggest that the value of motor reliability may be far greater than the value of energy efficiency, and that motor reliability alone may justify the selection of a new motor versus rewinding.

8. A simplified method for producing customized horsepower breakpoint curves was developed as part of this project and is available at:

*[www.advancedenergy.org/motors\\_and\\_drives/horespower\\_breakpoint/tool](http://www.advancedenergy.org/motors_and_drives/horespower_breakpoint/tool)*

10. Motor reliability appears to have a great impact on the life-cycle cost of motor operations. The meager data suggest that the value of motor reliability may be far greater than the value of energy efficiency.



## **Phase I — The 100 Motor Study**

### **Introduction**

The total motor base in the United States exceeds 100 million motors and consumes more than 50 percent of all electricity generated in the country. Small motors (20Hp down to fractional horsepower) make up 99 percent of the motor population but consume only 25 percent of all generated electricity [1, 4, 22, 36]. Large motors — while only one percent of the general motor population — consume 25 percent of all electricity generated in the United States and are primarily located in commercial and industrial applications.

Electric motors convert electrical energy into mechanical work at such a magnitude that their energy costs eclipse their initial purchase cost. In fact, 10 years of full time operation of an energy efficient 50Hp motor at the current average motor list price and average energy cost of \$0.05 per kWh shows initial cost accounts for less than one percent of life-cycle costs, while energy costs make up 99 percent of the life-cycle costs. Therefore, any increase in operational efficiency can have significant impacts on the life-cycle costs of the motor, particularly in terms of payback on the incremental cost of a higher efficiency motor. Because these motors are heavy consumers of electricity, their efficiency has significant impact on their replacement economics.

This phase of the project report discusses the first attempt to characterize the population of motors through a general field study and subsequent IEEE 112B testing of displaced old, in-service motors. Its purpose is to update efficiency and operating point assumptions in commonly used motor management tools such as MMr+. The results of lab testing on the old motors in comparison to the newly installed NEMA Premium™ motors are interpreted in terms of its effects on the economics of motor replacement.

### **Problem Statement**

The hypothesis is, that with hard data, the economics of motor repair versus replace decisions could change significantly. If true, this could appreciably boost the efficiency of the industrial motor population through increased penetration of high efficiency motors, such as the NEMA Premium™ line.

The energy savings from motor replacement depend on the difference between the efficiency of the new motor and that of the old motor. However, more investigating has been done on new motor efficiency than the actual running efficiency of older motors in the field. Motors that have operated for years, experiencing failures and repairs, are believed to have efficiency below the nameplate efficiency.

The difference in operational efficiency is highly dependent on several factors, including efficiency and operating speed of the old motor, efficiency and operating speed of the new motor, loading condition and loading type. New induction motor efficiency improvements have been well studied [4, 5, 19, 20, 24] and are controlled through standards set forth in the Energy Policy Act of 1992. Motors currently operating in industry, referred to here as *old motors*, also have been surveyed to determine population distributions within particular industries or geographical locations [30]. Additionally, several authors have considered the economics of motor repair versus replace decisions from a theoretical stance [7, 12, 15, 31, 36].

While these studies concede the importance of motor loading on the effective operational efficiency of the motor, they do not utilize standard testing methods to determine this efficiency but rather assume nameplate values for their comparisons. Motor decision tools — such as MM+, published by DOE to aid motor users in selecting the best motor management options — assume that a motor operates near its nominal efficiency if loading condition is not known. If the motor load is between 25 percent and 125 percent of rated load, then the software interpolates an average efficiency based on all motors in its database (MM+). Additionally, some studies [8, 9] have shown that motor repair can change the operational motor efficiency, for better or worse. Therefore, old motor efficiency is a large unknown in the payback equation.

Since the efficiency of the motor to be replaced is such a critical component of the economic analysis, it is important to understand whether this assumption of nominal efficiency is valid. The purpose of this study was to determine the appropriateness of assuming the actual efficiency of an old motor is near its nominal efficiency through laboratory testing of old motors, where nominal efficiency is defined as the full load efficiency printed on the nameplate of the motor or the MM+ default value for the motor at full load when no efficiency is printed on the nameplate. The appropriateness of the nominal efficiency assumption was then scrutinized by comparing nominal efficiency to tested efficiency as if the loading condition is not known, and then considering the efficiency of the motor at its current loading condition.

### **Phase I Summary**

To test the appropriateness of the nominal efficiency assumption, this project installed 100 NEMA Premium™ motors in industry while testing the displaced old motors in Advanced Energy's accredited lab. Savings and paybacks are calculated, providing powerful case study information to disseminate to industrial and commercial motor users. In addition, the actual tested efficiency of the old motors is available to replace anecdotal estimates of baseline efficiency that are used in virtually all motor calculation software packages in use.

For the purposes of this study, nominal efficiency was assumed to be the nameplate efficiency, when one is listed, and the default efficiency value from the MM+ database for a standard motor with the same horsepower, speed, frame and enclosure ratings. Based on testing results of 78 out of 100 surveyed motors, it was determined that the tested efficiencies at rated load of the displaced motors do not deviate significantly from their nominal efficiency, particularly when nominal is derived from the MM+ database. When considering the operating conditions and load factors of the old motors, the operating efficiency averages -1.58 percent from the nominal efficiency. By comparison, new NEMA Premium™ motors showed no significant deviation between their tested value and their nominal nameplate value, as well as between their operational efficiency and nominal efficiency.

However, while the tested efficiencies of the old motors did not deviate with statistical significance from either the nominal or actual tested operational efficiency, the deviations were appreciable as reflected in the overestimates of the economics of annual energy cost savings. Neither using the nominal efficiency, nor using MM+, consistently provided an accurate depiction of the annual energy cost savings, varying from overestimating by 1.9 percent to more than 13.5 percent. This is likely due to the loading conditions observed, where just under 30 percent of observed motors operated at less than 50 percent of their rated load — significantly lower than the often assumed load of 75 percent. Therefore, it is recommended that future motor decision tools focus on proper motor sizing and more accurate economic evaluations. It is also recommended that a future study add at least 300 more data points to this study to provide statistically significant findings on efficiency deviations.

### **Phase I Approach**

The 100 Motor Study concepts seemed simple enough: offer facilities free, new NEMA Premium™ motors in exchange for old, in-service motors; ship the old motors to Advanced Energy; test them and then report on the results. It was much more difficult than initially believed to find willing participants and motors that met the established selection criteria.

#### *Selection Criteria*

Candidate motors had to meet several criteria to qualify for replacement through this program. The criteria were determined by sales records to include the most common motors in the mid-size horsepower range to replicate the operating conditions of the selected motors, by available funding and the need to obtain statistical significance within the 100 available data points. The criteria include:

- Horsepower rating of 50Hp, 75Hp, 100Hp or 150Hp

- Foot mounted, T or TS frame, NEMA Design B
- 1800RPM synchronous speed rating (4-pole design)
- At least 4,000 operating hours each year
- Constant loading condition (little fluctuation or impact loading)
- Line energized; not controlled by an adjustable speed or variable frequency drive
- Manufactured before 1997, with preference for motors manufactured before 1992 (due to manufacturing ramp-up to meet 1997 deadline)

Energy efficient models of motors and even models that today are classified as NEMA Premium™ were available in the late 1980s and early 1990s, although not regulated. Therefore, even these higher efficiency motors were accepted into the study when found to meet the six established criteria in order to provide an accurate picture of the motors within this pre-EPAAct population.

*Selected Motors*

To date, all 100 motors for this study have been identified for replacement, but only 78 have been returned to the Advanced Energy lab and tested due to lack of voluntary participation by facilities or availability of the motors from the supplier, especially as a result of major hurricane damage. The remaining 20 displaced motors will be tested, subsequent analysis completed and a revision of this report issued by June 2006. The 100 motors accepted into this study operated primarily in centrifugal load situations as either fans or pumps, as shown in Figure 1 below.

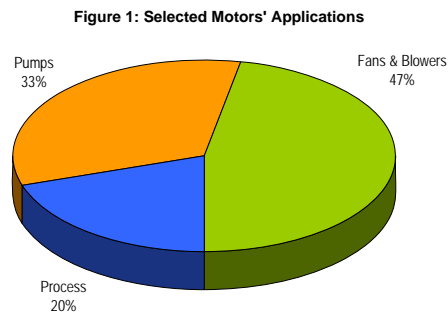

By industry, the motors are primarily from the food and beverage (24), chemical (23), and aggregate and mining (21) industries, with wood, pulp and paper (19), textiles (7), and facilities (6) also contributing a number of motors, as shown in Figure 2.

It has been significantly easier to find 75Hp motors matching the criteria set forth in the original design of this study. As a result, the study is slightly heavier in the lower

Horsepower ratings; the motors distribution is 26 x 50Hp, 31 x 75Hp, 23 x 100Hp, and 20 x 150Hp.

**Figure 2: Industries Represented**

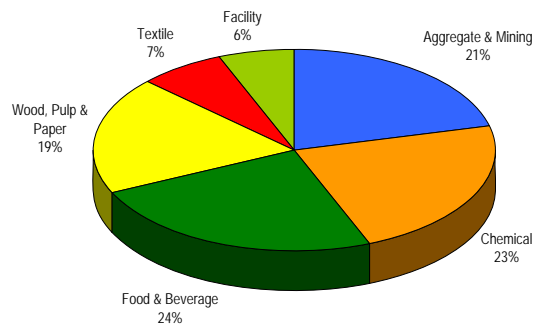

### *Testing Standard and Set Up*

Several induction motor testing standards are in use; however, the most common by far is IEEE Standard 112-1996 [3, 10, 14, 32]. This standard is the basis for many other testing standards, including the Canadian Standard Association Standard C390, IEC Standard 34-2 and JEC Standard.

The IEEE 112 Standard lists five testing methods, which differ in whether or not they determine the various categories of motor efficiency losses [18] and if so, how. Each of the methods measure input and output power to determine efficiency. Method A determines full load efficiency only and is most effective for testing small motors where it is difficult to segregate losses within the limits of instrumentation. Method B relies on direct measurement of losses through measuring motor input voltage, current, power and output torque and speed at seven dynamometer-coupled load points and six uncoupled voltage points to segregate losses for each category. It is the only method that allows measurement of stray load losses of the tested motor. Method C also measures input and output at several points, and then determines dynamometer system losses and divides the losses between the tested motor and the generator. This method is very similar to the IEC Standard. Method E, an equivalent standard to the JEC standard, does not measure output power and instead assumes percentage of input power as loss. Method F, like Method E, is an indirect standard, and uses the equivalent circuit for the motor and a calibrated load point to calculate the segregated motor losses.

Since it is the only method that allows direct measurement of all loss categories, IEEE 112, Method B, provides the most accurate segregation of efficiency losses and therefore is referenced as the required testing standard for motor efficiency in the NEMA MG-1 and the Energy Policy Act of 1992 [5, 19, 27]. Therefore, this test standard and method was used for testing old motors accepted into this study.

The tests were performed at Advanced Energy's motor lab on N.C. State University's Centennial Campus. This motor test facility was the first in the world to complete the National Institute of Standards' (NIST) National Voluntary Lab Accreditation Program (NVLAP) and has conducted more than 1,000 IEEE 112-B tests in its 15-year history. The facility has five active dynamometers that allow it to perform tests from the fractional horsepower range up to 300Hp with a maximum of 0.20 percent uncertainty in any measured values and with high test reproducibility.

Tests were conducted on one of three dynamometers with input power measured on the same power measurement panel. The primary dynamometer is a Clayton water brake power absorption unit. This unit converts mechanical power into heat through the friction of the water interacting in the vanes of the stator and rotor of the water brake. The heat is then dissipated by pumping the water through a chiller. The secondary dynamometer is a 300Hp direct current generator. In this setup the motor drives the generator, which produces an electrical power output that must be dissipated as heat through resistance. The figures on page 22 illustrate the setup with each dynamometer. The tertiary system consisted of upgrading the power absorption unit in the primary setup from a water brake to an eddy current brake, providing greater load control and less torque ripple.

The secondary system was used when the primary system was retired from service for a scheduled lab system upgrade. The tertiary system replaced the primary system at that time. Internal lab quality assurance, including retesting of a handful of motors, guarantees that the efficiency results from one dynamometer are reproducible on the other dynamometer, so this setup change was not a source of error within this study.

**Figure 3a: Primary Dynamometer Set Up**

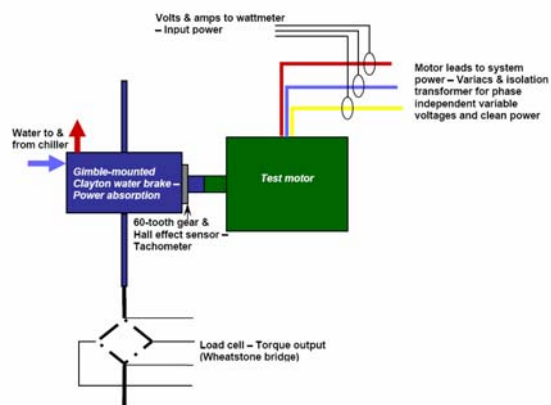

Figure 3b: Secondary Dynamometer Set Up

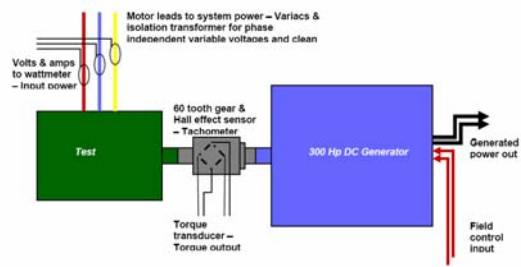
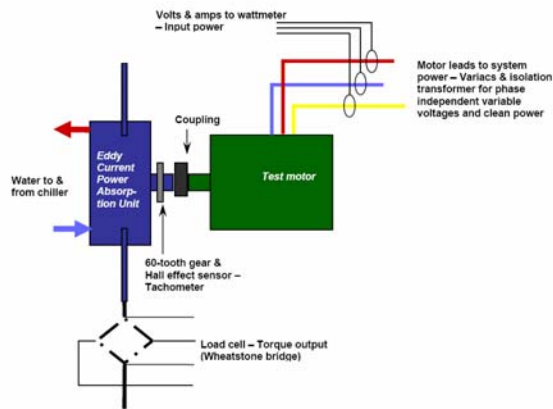

Figure 3c: Tertiary Dynamometer Set Up



### Phase I Outcomes

The deliverables for this project included 100 motors replaced with NEMA Premium™ motors, testing results from the 100 displaced old motors, analysis of the testing results, creation of case studies from the data and dissemination of the results. Dissemination of the results is discussed under Phase IV • Dissemination.

### Testing Results

A summary of the testing results as well as calculated values used for the analyses of the displaced old motors are shown in Table 1. Results for the NEMA Premium motors are shown in Table 2. Complete testing results and calculations for the analyses are attached.

Additionally, one may note that only 94 data points presented. Four of the displaced old motors failed during testing. Interestingly, all four motors operated in the aggregates and mining industry and were observed operating at loads below 50 percent of their rated horsepower. Another two motors were lost or damaged in shipping and therefore unable to be tested.

**Table 1: 'Old' Motor Testing and Analysis Results**

Hp	Annual Run Hours	Observed Operating Load	'Old' Motor Efficiencies				NEMA Premium Efficiencies		NEMA Premium Price	Actual* Saving	Difference in Estimated Savings	
			Full load		At Operating load		Nominal	At Operating Load			Using Nominal	Using Motor Master
			Nominal	Tested	Calc'd from Testin g	Motor Master						
50	6540	38.4%	91.30	90.64	92.10	87.70	94.50	93.96	\$3,183	\$128	-3.9%	3.4%
50	5000	83.2%	91.70	91.75	92.27	91.50	94.50	95.05	\$3,183	\$314	-0.8%	1.8%
50	5500	79.2%	91.30	91.14	91.86	91.60	94.50	95.07	\$3,183	\$381	1.2%	2.1%
50	7810	76.4%	91.30	91.61	92.56	91.60	94.50	95.07	\$3,183	\$405	5.7%	6.9%
50	8520	80.0%	94.10	91.59	92.38	94.80	94.50	95.07	\$3,183	\$495	-8.5%	-9.3%
50	8000	62.8%	91.30	89.62	89.59	91.30	94.50	94.91	\$3,183	\$749	3.1%	4.8%
50	8000	86.7%	93.00	93.83	94.39	93.40	94.50	95.01	\$3,183	\$114	-2.0%	-1.4%
50	8000	98.2%	91.30	91.23	91.77	91.30	94.50	94.75	\$3,183	\$642	10.9%	12.6%
50	8000	22.2%	94.50	93.29	92.01	91.10	94.50	92.83	\$3,183	\$41	-10.8%	-8.1%
50	8000	28.8%	94.50	93.35	92.84	92.40	94.50	93.33	\$3,183	\$31	-10.8%	-9.0%
50	8000	82.6%	91.30	89.99	90.56	91.50	94.50	95.05	\$3,183	\$821	7.5%	9.3%
50	8000	85.4%	91.30	91.59	92.39	91.50	94.50	95.03	\$3,183	\$487	8.1%	9.9%
50	8000	88.1%	90.20	91.09	91.94	91.50	94.50	94.99	\$3,183	\$586	15.8%	10.3%
50	8000	87.5%	90.20	91.51	92.33	91.50	94.50	95.00	\$3,183	\$506	15.6%	10.2%
50	8000	67.5%	91.30	91.52	91.80	91.40	94.50	95.00	\$3,183	\$472	4.1%	5.9%
50	8000	52.5%	93.60	92.65	93.30	93.10	94.50	94.62	\$3,183	\$149	-7.6%	-5.4%
50	8000	73.5%	94.50	94.31	94.55	94.80	94.50	95.06	\$3,183	\$80	-10.8%	-9.6%
50	8000	33.9%	95.00	94.21	92.69	92.90	94.50	93.68	\$3,183	\$74	-12.0%	-9.0%
50	8000	48.4%	93.00	92.88	91.41	92.80	94.50	94.45	\$3,183	\$324	-5.9%	-5.4%
50	8000	40.6%	95.00	93.53	92.48	93.60	94.50	94.08	\$3,183	\$142	-12.2%	-9.5%
50	8000	45.2%	95.00	93.99	93.01	94.10	94.50	94.31	\$3,183	\$128	-12.3%	-10.2%
50	8000	106.9%	82.40	92.25	92.21	91.30	94.50	94.43	\$3,183	\$518	88.5%	12.4%
50	8000	91.1%	91.30	91.89	92.50	91.40	94.50	94.93	\$3,183	\$480	9.4%	11.3%
50	8000	93.9%	91.00	91.68	92.31	91.40	94.50	94.87	\$3,183	\$522	12.0%	11.6%
75	6540	49.4%	91.70	92.30	92.23	90.80	95.40	94.85	\$5,118	\$345	2.8%	3.8%
75	6540	47.5%	91.70	91.65	91.04	90.30	95.40	94.76	\$5,118	\$478	2.4%	4.5%
75	6540	48.9%	91.70	92.18	91.80	90.70	95.40	94.82	\$5,118	\$398	2.7%	4.0%
75	3250	87.2%	91.70	92.06	92.84	91.80	95.40	95.46	\$5,118	\$299	1.6%	1.5%
75	3250	82.1%	91.70	91.40	92.43	91.90	95.40	95.49	\$5,118	\$331	1.1%	0.9%
75	4200	57.0%	95.40	94.54	94.38	91.20	95.40	95.13	\$5,118	\$71	-6.7%	0.8%
75	8400	108.3%	91.70	91.58	91.46	91.70	95.40	94.96	\$5,118	\$1,307	20.1%	17.0%
75	4200	33.9%	95.00	93.75	92.92	91.60	95.40	94.02	\$5,118	\$64	-6.3%	-3.9%
75	8400	92.2%	91.70	92.46	93.04	91.80	95.40	95.40	\$5,118	\$734	16.1%	15.5%
75	8520	78.9%	93.00	94.06	94.78	94.30	95.40	95.49	\$5,118	\$189	5.9%	-0.5%
75	6500	89.9%	91.70	92.53	93.02	91.80	95.40	95.43	\$5,118	\$566	10.5%	10.2%
75	8000	99.3%	95.40	94.92	95.18	95.40	95.40	95.25	\$5,118	\$20	-6.7%	-7.7%
75	8000	77.5%	95.40	94.83	95.39	95.50	95.40	95.49	\$5,118	\$24	-6.7%	-6.8%
75	6240	112.7%	91.70	92.44	92.12	91.70	95.40	94.77	\$5,118	\$763	14.0%	10.6%
75	6240	109.4%	91.70	91.61	91.76	91.70	95.40	94.91	\$5,118	\$881	13.4%	10.8%
75	6240	112.2%	91.70	92.61	92.65	91.70	95.40	94.80	\$5,118	\$610	13.9%	10.6%
75	7920	13.9%	91.70	92.48	87.90	76.10	95.40	92.48	\$5,118	\$222	-3.5%	11.2%
75	7920	77.9%	91.70	91.08	91.61	91.90	95.40	95.49	\$5,118	\$977	11.4%	10.9%
75	8000	103.1%	91.70	91.74	92.27	91.70	95.40	95.14	\$5,118	\$962	17.6%	15.9%
75	8000	88.0%	95.40	94.67	95.15	95.50	95.40	95.45	\$5,118	\$84	-6.7%	-7.0%
75	8000	28.7%	95.00	94.28	92.99	93.00	95.40	93.67	\$5,118	\$65	-6.0%	-5.5%
75	8000	85.3%	91.00	91.62	92.10	91.90	95.40	95.48	\$5,118	\$937	17.4%	12.7%
75	8000	37.7%	94.10	92.80	91.38	92.10	95.40	94.26	\$5,118	\$360	-3.7%	-1.5%
75	8000	38.7%	91.70	92.69	88.72	88.30	95.40	94.31	\$5,118	\$739	2.4%	8.9%
75	8000	48.3%	94.10	93.50	92.76	93.50	95.40	94.80	\$5,118	\$320	-2.8%	-2.8%
75	8000	31.0%	91.70	90.88	84.23	86.50	95.40	93.83	\$5,118	\$1,073	0.6%	8.9%
75	8000	79.3%	91.70	92.35	92.92	91.90	95.40	95.50	\$5,118	\$658	12.0%	11.4%
75	8000	27.3%	91.70	91.61	91.25	85.60	95.40	93.57	\$5,118	\$213	-0.3%	8.4%
100	6540	57.0%	92.30	92.87	93.49	91.50	95.00	94.65	\$6,167	\$233	3.3%	4.9%
100	6540	51.8%	92.30	93.18	92.11	91.30	95.00	94.41	\$6,167	\$426	2.5%	3.8%
100	8760	23.1%	92.30	89.55	85.17	85.30	95.00	92.29	\$6,167	\$874	-0.8%	8.3%
100	8760	18.3%	90.20	91.01	82.62	82.10	95.00	91.80	\$6,167	\$924	1.3%	10.3%



100	8520	83.7%	92.30	91.68	92.49	92.20	95.00	95.23	\$6,167	\$1,057	11.4%	13.4%
100	8520	70.5%	94.10	94.01	94.91	94.50	95.00	95.09	\$6,167	\$57	-0.9%	-2.6%
100	6000	33.3%	93.00	93.49	93.31	87.90	95.00	93.19	\$6,167	-\$13	-2.1%	4.4%
100	6000	41.7%	92.30	93.57	93.72	89.60	95.00	93.81	\$6,167	\$13	0.4%	4.1%
100	8000	49.2%	95.50	95.25	94.12	94.60	95.00	94.27	\$6,167	\$32	-7.3%	-6.7%
100	8000	55.6%	92.30	93.19	92.18	91.50	95.00	94.59	\$6,167	\$587	5.0%	6.7%
100	8000	72.9%	92.30	91.71	91.89	92.10	95.00	95.14	\$6,167	\$1,030	8.3%	10.0%
100	8000	83.6%	93.60	92.82	93.31	94.60	95.00	95.23	\$6,167	\$689	2.5%	-2.0%
100	8000	68.7%	90.20	91.30	90.66	92.00	95.00	95.05	\$6,167	\$1,332	18.2%	9.2%
100	8000	54.8%	95.40	94.93	93.38	94.90	95.00	94.55	\$6,167	\$277	-7.1%	-6.9%
100	8000	93.8%	95.40	93.26	93.74	95.40	95.00	95.15	\$6,167	\$563	-8.2%	-7.2%
100	8000	12.6%	95.00	95.51	89.51	84.10	95.00	91.17	\$6,167	\$97	-5.6%	1.6%
100	8000	101.0%	95.00	95.40	95.63	94.50	95.00	95.00	\$6,167	-\$270	-5.6%	-2.2%
100	8000	94.4%	92.30	90.48	91.14	92.20	95.00	95.14	\$6,167	\$1,657	12.3%	13.9%
100	8000	49.3%	93.60	93.92	92.16	91.10	95.00	94.28	\$6,167	\$457	-0.8%	5.7%
100	8000	55.3%	92.40	93.67	93.48	91.50	95.00	94.58	\$6,167	\$261	4.5%	6.6%
100	8000	62.8%	92.40	93.68	93.95	91.70	95.00	94.88	\$6,167	\$249	5.9%	8.6%
100	8000	57.4%	92.40	93.64	93.64	91.50	95.00	94.67	\$6,167	\$255	4.9%	7.4%
150	8520	86.2%	93.00	93.13	93.77	92.90	95.87	96.38	\$9,301	\$1,516	14.4%	18.2%
150	8520	92.8%	92.90	92.93	93.45	93.00	95.87	96.33	\$9,301	\$1,809	16.5%	18.9%
150	6500	94.9%	93.00	93.78	94.21	93.00	95.87	96.31	\$9,301	\$1,018	11.5%	13.8%
150	5000	79.3%	93.00	94.96	95.32	92.80	95.87	96.38	\$9,301	\$328	6.1%	8.5%
150	8400	94.7%	93.60	93.78	94.28	93.00	95.87	96.31	\$9,301	\$1,271	11.7%	18.8%
150	6240	101.5%	93.00	93.08	93.53	93.00	95.87	96.19	\$9,301	\$1,336	11.9%	13.6%
150	6240	94.4%	93.00	91.26	91.89	93.00	95.87	96.31	\$9,301	\$2,101	10.8%	13.0%
150	7920	73.1%	93.00	94.69	94.87	92.70	95.87	96.33	\$9,301	\$662	10.6%	14.4%
150	7920	44.5%	93.00	92.86	90.62	90.40	95.87	95.53	\$9,301	\$1,425	5.0%	12.4%
150	6000	73.8%	93.00	94.54	94.82	92.70	95.87	96.34	\$9,301	\$526	7.2%	10.2%
150	8000	61.9%	93.00	94.23	93.66	92.10	95.87	96.13	\$9,301	\$970	8.5%	13.6%
150	8000	83.6%	93.00	94.58	95.05	92.90	95.87	96.39	\$9,301	\$695	12.8%	16.3%
150	8000	49.5%	93.00	92.46	90.14	91.40	95.87	95.74	\$9,301	\$1,834	6.1%	11.4%
150	8000	80.5%	93.00	92.54	92.68	92.80	95.87	96.39	\$9,301	\$1,906	12.2%	16.1%
150	8000	75.2%	94.10	90.60	90.04	92.80	95.87	96.35	\$9,301	\$3,123	5.3%	14.6%
150	8000	62.6%	93.00	94.61	94.69	92.10	95.87	96.15	\$9,301	\$573	8.7%	13.9%
150	8000	63.4%	94.50	92.59	92.43	92.20	95.87	96.17	\$9,301	\$1,521	2.2%	13.7%
150	8000	72.8%	93.00	92.47	92.77	92.70	95.87	96.33	\$9,301	\$1,654	10.7%	14.5%
150	8000	66.5%	94.10	93.92	94.10	94.80	95.87	96.23	\$9,301	\$896	4.3%	2.7%
150	8000	73.6%	93.00	93.35	93.36	92.70	95.87	96.34	\$9,301	\$1,390	10.8%	14.7%

\* At the U.S. average industrial electric rate of \$0.058/kWh (Energy Information Administration, February 2006)

Table 2: NEMA Premium™ Test Results			
Hp	Nameplate Rated Load Efficiency	Tested Efficiency at Rated Load	Deviation
50	94.50%	94.90%	0.40%
50	94.50%	94.05%	-0.45%
75	95.40%	95.71%	0.31%
75	95.40%	95.37%	-0.03%
75	95.40%	94.30%	-1.10%
75	95.40%	94.33%	-1.07%
75	95.40%	94.63%	-0.77%
75	95.40%	95.05%	-0.35%
75	95.40%	95.21%	-0.19%
75	95.40%	94.68%	-0.72%
75	95.40%	95.24%	-0.16%
75	95.40%	95.14%	-0.26%
75	95.40%	95.20%	-0.20%
100	95.00%	94.72%	-0.28%
150	95.80%	96.25%	0.45%
150	95.80%	95.47%	-0.33%
150	95.80%	95.60%	-0.20%
150	96.20%	96.36%	0.16%
150	95.80%	96.33%	0.53%
150	95.80%	96.06%	0.26%

### *Comparisons*

The value of this testing is to determine the accuracy of results that a plant engineer or maintenance manager could obtain from existing motor decision tools with only information gathered by observing the motor in operation: current, voltage and nameplate information. Therefore, the observational data is compared to the testing results — referred to as the actual efficiency of the motor — to determine the accuracy of several ways one may choose to determine the annual energy cost savings of the motor. As a result, the findings are discussed in terms of the deviation between the tested, or actual, efficiency and the comparative efficiency. Variance is used instead of standard deviation to avoid confusion between calculated deviation in efficiencies and variation in the data.

### Rated Load Efficiency

For the purposes of this analysis, nominal efficiency is defined as the nameplate efficiency or the MM+ efficiency for a standard motor of the same size and speed ratings and enclosure type at rated load. Overall, there is no significant deviation in tested rated load efficiency compared to the nominal. The difference, or deviation, in the tested efficiencies is negligible at 0.060 percent, particularly compared to the variance, a measure of the scatter of the data (the higher the variance, the more scattered the data; the lower the variance, the less scattered and more statistically significant the results are). The relative scatter of data indicated by this deviation and variance are shown in Figure 6, where the tested results are plotted against the nominal efficiency. Ideally, the data points should fall directly along the 45 degree line, where Nominal = Tested, or the deviation is 0.00 percent. As seen in Figure 6, the data follows the line well with a significant number of points both above and below the line, resulting in the small deviation. However, the data ranges well above and below the line, resulting in the larger variance. The test results of 20 NEMA Premium™ motors are shown for comparison and to serve as a control. They demonstrate a larger deviation than the old motors at 0.200 percent below nominal efficiency but a significantly smaller variance, or range of results, of only 0.22 percent.

There are clear differences in the deviations among the various horsepower ratings tested; however, none of the horsepower ratings demonstrated statistically significant deviations. The 50Hp motors tested an average of 0.105 percent below their average nominal efficiency with a large variance of 5.428 percent. By comparison, the 75Hp motors tested an average of less than 0.033 percent from the average nominal efficiency, with the least variance of all horsepower ratings at only 0.547 percent. On the other hand, the 100Hp motors showed the greatest deviation between tested and nominal with a difference of

0.149 percent (1.050 percent variance), and 150Hp motors tested barely lower than nominal with a negligible deviation of -0.022 percent and variance over 2.000. Of course, with such large variances in comparison to the deviations, none of the results are statistically significant.

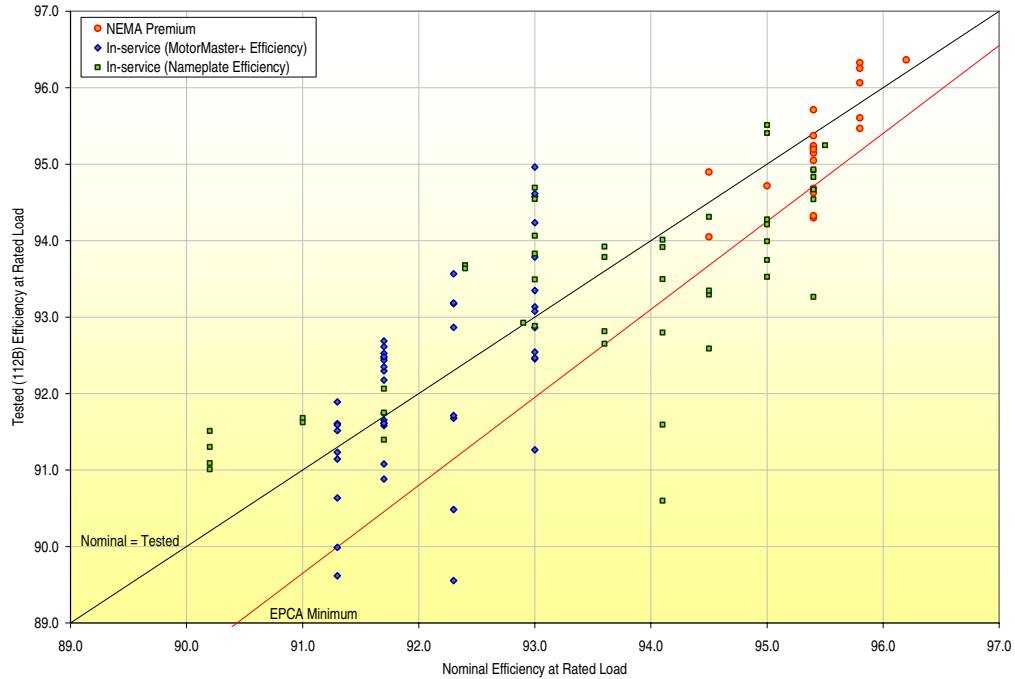

Figure 4: Nominal vs. Tested Efficiencies for Displaced ‘Old’ Motors

Since the nominal efficiency is derived from two sources, the results are compared by source to determine any confounding effects:

*Tested versus Nominal (Nameplate)*

Forty-eight motors included in the analysis had an efficiency value printed on their nameplates. These ranged from well below the required EPCA level to the current Premium level, as seen in Table 1. Overall, motors with a nameplate value tested an average of 0.021 percent above their nameplate value, but, as shown by the green squares in Figure 6, still ranged greatly with a variance of 3.327 percent. Therefore, this deviation is not statistically significant. Interestingly, many of the greatest deviations seen among the data come from motors with a nameplate nominal efficiency, resulting in the large variance and resulting statistical insignificance.

*Tested versus Nominal (MotorMaster+)*

Since NEMA did not require that efficiency values be printed on a motor’s nameplate before 1991, a 46 of the motors accepted into this study required outside assistance to determine

a nominal efficiency. Because of its widespread use, MotorMaster+ was selected. The default standard efficiency for a motor of the same size, speed rating and enclosure type is assumed as the nominal efficiency for motors in this group. As a result, there are only four nominal efficiencies for motors in this group, hence the vertical lines of blue diamonds in Figure 4. However, these motors tested an average of 0.102 percent above their assumed nominal efficiency. Still, with a variance of 0.923 percent, this is clearly the closest among the comparisons of tested versus nominal. Yet, the large variance compared to the deviation results in no statistical significance.

### Operational Efficiency

Because motors rarely operate at exactly their rated load, and this significantly impacts the amount of energy the motor requires, it is also important to consider the operational efficiency, or efficiency of the motor under its current operating conditions, and how that compares to common methods for assuming an operational efficiency — the nominal efficiency value at rated load and the MM+ value for operational efficiency.

For this exercise, load is calculated by two methods. Whenever input power data was able to be collected for the motor, the load is calculated by subtracting the no load power measured during testing from the observed power measurement, and the difference divided by the rated power of the motor to determine load as a percent of rated load. When only current and voltage data is available, the load is calculated using corrected average current compared to nameplate according to the method listed in the EASA Technical Article “Calculating Motor Loads,” where motor load is expressed as a percent of the motor’s rated load and calculated as

$$Load = 1 - \frac{FLA - I_{measured}}{FLA - NLA}$$

where *FLA* is the nameplate rated load current, *NLA* is the measured current with no connected load at rated voltage, and *I<sub>measured</sub>* is the current measured on site corrected to rated voltage. *NLA* were measured during the motor test.

Then, the efficiency values at the seven load points collected during the IEEE112B testing of the motor is modeled in SAS JMP to find a quadratic equation describing the efficiency curve. The equation is evaluated at the load point to estimate the motors actual operational efficiency. For comparison, the new motor efficiency curves are averaged together by horsepower and then the average is modeled in SAS JMP and the resulting quadratic equation evaluated at the load point to determine the operational efficiency of the new or replacement motor. Additionally, the calculated load is entered into MM+ with information on the motor’s size, speed and enclosure to find MM+’s estimation of the operational efficiency.

### Motor Load Conditions

Before looking at the operational efficiencies, it is useful to learn as much as possible from the loading conditions under which these motors are operating. As discussed earlier, 80 percent of the motors accepted into this study operated a centrifugal load. Looking at the actual load that many of these motors operated, it is much lower than the 70-75 percent of rated load that is normally assumed. In fact, the average actual load is 68.2 percent. Since efficiency is a function of motor load, this could have significant impact on the economics of motor replacement.

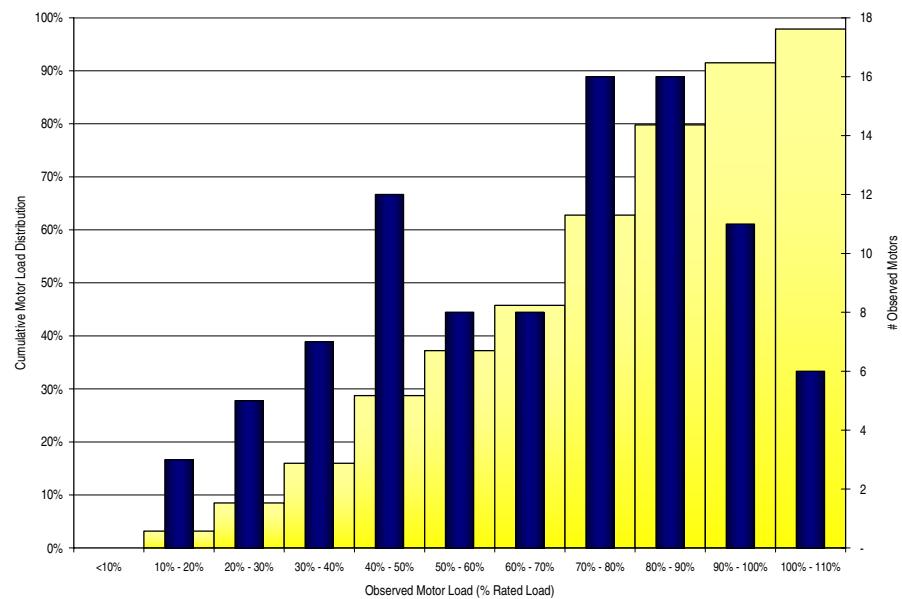

Figure 5: Observed Motor Load Frequency Distribution

### Actual versus Nominal

One method that may be employed to estimate the annual energy cost savings of replacing a motor may be to use the nominal efficiency of the motor in the payback equation. Therefore, the deviation of actual efficiency to the nominal efficiency is compared.

Results show that the actual efficiency averages 0.284 percent below the nominal efficiency for the motor. However, the deviation is not statistically significant since the variance of the deviation is 5.061 percent. When the nominal efficiency is taken from the nameplate, the average deviation is just below the population average at -0.364 percent, with a similarly large variance of 6.166 percent.

Likewise, when the nominal comes from MM+, the average deviation is just above the population average at -0.201 percent, with a variance of 4.005 percent. With such a range

of results as evidenced by the large variances, none of these results are statistically significant, but are clearly appreciable.

#### *Actual versus MotorMaster+ (MM+) at Operating Load*

Another method to estimate the annual energy cost savings of replacing a motor may be to utilize MM+. In this case, since motor characteristics (such as size and speed rating and enclosure type) are selected from a drop box, the only other information required is the load condition.

The efficiency estimated by MM+ at the actual load averages 0.717 percent lower than the actual efficiency of the motor at its operating condition. However, the variance is appreciable at 3.725 percent, indicating that the deviation, while large, is not statistically significant.

#### Economics

In addition to requiring the old and new motor efficiencies, the simple payback calculation requires the motor load to determine the energy draw (kWh) of the motor. Taking into account the differences in the motor efficiencies and the motor load, how does this affect the economics of motor replacement?

First, motor economics are ruled by the simple payback equation (shown below) where the motor is repaired if the simple payback exceeds the corporate standard, and the motor is replaced if the simple payback period is less than the corporate standard. The denominator of this equation calculates the annual energy cost savings, and since the cost to repair or replace a motor varies by site, the annual energy cost savings will be used as an economic indicator for this analysis

$$SPP = \frac{X_{replace} - X_{repair}}{0.746 \times Hp \times SF \times C \times HPY \left( \frac{100}{\eta_{old}} - \frac{100}{\eta_{new}} \right)}$$

where SPP is the simple payback period in years,  $X_{replace}$  is the purchase price of the new motor including any discounts,  $X_{repair}$  is the cost to repair the old motor, Hp is the horsepower rating of the motor, SF is the motor operating load, expressed as a percent of full load, C is the average facility electric cost (\$ per kWh), HPY is the annual operating hours of the motor, and  $\eta_{old}$  and  $\eta_{new}$  are the full load efficiency of the old and new motor, respectively.

As seen in Table 1, the actual annual energy cost savings vary greatly from zero to more than \$2,300 per motor. This value is based on the actual load, which accounts for the minimum power required to spin the machine, the efficiency resulting from a quadratic model of the tested efficiency curve, annual operating hours estimated by the facility and

the average U.S. industrial electric rate (currently \$0.0638 per kWh). The total value of energy saved by participating facilities is even greater since many are in California and New York, where energy prices are considerably higher. These values allow us to determine which estimating technique produces the most accurate economic model for motor repair and replace decisions.

Unlike previous calculations, the difference between the actual savings and the different models is compared by the percent difference in annual energy savings normalized by the NEMA Premium™ list price of a new motor for the same horsepower rating, speed, enclosure, etc., or in equation form:

$$\% \text{ difference} = \frac{\text{Model} - \text{Actual}}{\text{NEMA\_Premium\_List}}$$

This method normalizes the data and keeps the statistics directly related to the annual energy cost savings — the value that provides the payback and justifies the decision whether to repair or replace the motor.

Unfortunately, none of the following methods show very accurate results as compared to the actual energy cost savings: neither using the nominal efficiency at load nor using the load to find a MotorMaster+ (MM+) operational efficiency. Using the nominal efficiency at load provides the closest estimate to actual savings, overestimating by an average of 4.57 percent with statistical confidence greater than 99.95 percent. On the other hand, using the actual load to find a MM+ operational efficiency overestimates the annual savings by more than 5.78 percent with statistical confidence greater than 99.999 percent. Since the actual load is used to calculate these values, it results in less energy consumption; therefore, efficiency deviations and horsepower ratings play a significant role. The nominal efficiency overestimates the actual efficiency by 0.284 percent while the MM+ estimated operational efficiency at the actual load underestimates the actual efficiency by nearly one percent creating the range of percent difference values seen. However, since all percent difference values are normalized by the list price of a new NEMA Premium™ motor, which is not linear by horsepower rating, the difference ranges by horsepower. A summary of average percent differences is shown in Table 3.

<b>Table 3: Percent Difference in Annual Energy Savings by Estimation Method</b>		
<b>Efficiency Source</b>	<b>Actual Load</b>	
	<b>Nominal</b>	<b>MM+</b>
50Hp	3.51%	1.49%
75Hp	4.16%	5.10%
100Hp	1.91%	4.15%
150Hp	9.36%	13.66%

## Case Studies

One deliverable of this project includes case studies. To protect the identity of the participating facilities and to increase the number of motors represented by each sample, the cases were divided by state and by industry. Each of the nine case studies is attached. Since only 78 of the 100 motors have been tested to date, revised case studies will be included with the revision of this report. Final versions of the case studies will be available electronically at [www.advancedenergy.org/motors\\_and\\_drives/knowledge\\_library](http://www.advancedenergy.org/motors_and_drives/knowledge_library). The case studies are organized by state and industry:

State	Industry
California	Aggregates & Mining
New York	Chemical
North Carolina	Facility
	Food & Beverage
	Textile
	Wood, Pulp & Paper

## **Conclusions and Recommendations**

This study was the first attempt to characterize the motor population through a general field study and subsequent IEEE 112B testing of displaced old in-service motors in order to update efficiency and operating point assumptions in commonly used motor management tools such as MM+. One hundred motors were identified from several industries all over the states of California, New York and North Carolina and participating sites received a new NEMA Premium™ motor for each motor accepted into the program. The displaced old motors were returned to Advanced Energy for IEEE 112B testing and analysis.

Analysis of the different methods for calculating the economics of motor replacement provided statistically significant results indicating appreciable inaccuracies, all with greater than 95 percent confidence. The first method takes the stance of personnel who simply look at the motor nameplate and the listed efficiency for the replacement motor but use measured operating power to determine the motor load. This method overestimated annual energy cost savings by an average of 4.57 percent. Another method relies on the popular and publicly available motor decision tool, MotorMaster+ (MM+). The same load condition is evaluated in MM+ using the motor size and speed ratings, enclosure type and nameplate efficiency to select efficiency level, if one is printed on the nameplate. Although the efficiencies do not deviate significantly, they are noted to be considerably different than the actual tested operational efficiency of the motor, averaging nearly a one percent deviation



when evaluated at the actual load. As a result, the economics calculated by MM+ exceed the annual energy cost savings by more than 5.78 percent when evaluated at load.

Therefore, it is recommended that a more consistently accurate method of determining annual energy cost savings be developed since none of the methods provide an accurate evaluation of the economics of motor replacement. When MM+ is used replacement with a new motor may be overly favored. A more accurate tool will shift this balance in an unknown direction, based on rate of adoption.

Additionally, this new tool should focus more on motor management and specifically on proper motor sizing. Loading conditions on the observed motors were significantly lower than expected. In general, it is assumed that a motor operates at 70-75 percent of its rated load. However, the average actual load observed (where no-load current is considered in the calculation) was just over 68 percent of rated load. Moreover, the 100Hp motors' average actual load was merely 58 percent. This indicates gross oversizing of motors in industry and potential savings if a motor could be downsized at replacement, creating better economics for replacement since smaller motors cost less, and moving the operating condition closer to the motor's peak efficiency. However, personnel need to be made aware of the risks in downsizing and need help in calculating the proper motor size for an application.

Based on the results of this work, a sample of at least an additional 300 motors is needed to determine with statistical significance the accuracy of current motor decision tools and methods with regards to efficiency, and much more information is needed to determine the effects of repair on motor efficiency. The results of the IEEE 112B test method provide not just efficiencies, but segregated losses. However, without knowing whether each motor had been repaired or not, no useful conclusions could be derived, just hypotheses. Many facilities did not have motor maintenance records. This is highly recommended as a best practice that promotes better economical decisions by identifying trouble motors or applications. Such recordkeeping could also significantly aid future motor research.

## **Phase II – Economics of Motor Reliability**

### **Introduction**

During the past few years, motor efficiency has been the driving factor behind motor management policy, with many of the existing motor management tools providing the basis for making motor repair versus replace decisions. While these tools have served industry well, the issue of reliability is hardly addressed. Also, the motor lifetime savings computed by the tools based on efficiency do not consider the cost of lost production due to motor failure.

In view of the huge costs associated with downtime, motor reliability is now considered one of the most important factors in repair versus replace decisions. However, actual in-plant data on motor reliability is sparse. The goal of this project was to obtain in-plant historical motor data for the purpose of estimating the mean time between failure (MTBF) of new and rewind motors. This information was expected to serve as a body of knowledge for generating the necessary statistical metrics for assessing the economic impact of reliability. It was anticipated that if a relative value could be placed on motor reliability as a result of this study, then when a motor failed the user would have a more complete economic justification for either a repair or replace decision.

This phase of the project was initiated with a literature search to find published material on motor reliability. Also, a number of industry sources were contacted to obtain historical data of in-plant motor related activity. Out of about 150 plants contacted, only one plant was found that tracks MTBF, and only for new motor installations. Other sites that were found to be documenting motor activity collected motor information for inventory tracking purposes and did not distinguish between new and repaired motors in their records and did not maintain installation, failure and replace dates.

A thorough data search established that the statistically relevant data required to determine and compare MTBF for new and rewind motors in industry probably does not exist. The search for data was therefore discontinued due to project budget and schedule, and it was decided to summarize the qualitative and anecdotal information contained in available data, articles and reports collected for the final report.

This report presents some of the issues of motor reliability and also includes information on best practices that would encourage the documentation of the MTBF of new and rewind motors.

## Phase II Approach

The proposed task plan was to:

- Conduct a thorough literature search
- Identify up to 100 target companies for this study
- Select up to 10 companies to participate in the study
- Obtain relevant records from all participant companies
- Develop average life comparisons between new and rewound motors
- Place results in an economic model

### *Literature Search*

The literature search was performed by Advanced Energy and Washington State University (WSU). The WSU Energy Program Library searched for published material on electric motor reliability in the following databases available at the WSU Library website.

For business literature, the following ProQuest databases were searched:

- ABI/INFORM Dateline  
Business, economics: local and regional business publications.  
Contains news and analysis gathered from major business tabloids, magazines, daily newspapers, wire services, and city, state and regional business publications.
- ABI/INFORM Global  
Business, finance, economics: journals, company profiles, *Wall Street Journal* .  
Provides scholarly and comprehensive coverage of nearly 1,800 worldwide business periodicals; covers business theory and practice, economic conditions, management techniques and more; coverage: 1971 to present.
- ABI/INFORM Trade & Industry  
Business, economics: trade and industry periodicals and newsletters.  
Covers more than 750 business periodicals and newsletters with a trade or industry focus for every major industry, including finance, insurance, transportation, construction and more; coverage: 1971 to present.
- ProQuest Newspapers

Indexes and summarizes the full text of 70 national, regional and business newspapers.

- ProQuest Research Library

Comprehensive access to full-text journals across a wide range of subject areas, including business, education, literature, political science, and psychology; coverage: 1971 to present.

The EI Compendex database was searched for engineering and technical articles. EI Compendex is a comprehensive interdisciplinary engineering database with 7.5 million records, updated weekly, that reference 5,000 engineering journals and conference materials dating from 1969 to present. This database was accessed through Engineering Village 2, a web-based interface for information specialists and researchers in applied science and engineering.

The search was limited to items published after 1990 in both ProQuest and EI Compendex. To supplement the searches in ProQuest and EI Compendex, a multiple-database search was performed in DIALOG, an online provider of a wide range of electronic databases. This search was limited to English language publications from 1994 and later. The following specialized files were chosen:

- File 6: NTIS National Technical Information Service; provides summaries of unclassified government-sponsored research reports from 1964 to present.
- File 34: SciSearch; indexes significant articles and papers in the literature of science and technology; contains all the records published in the Science Citation Index, from 1990 to present.
- File 65: Inside Conferences; covers all papers presented at conferences received at the British Library Document Supply Center from 1993 to present.
- File 103: Energy Science & Technology; prepared by the U.S. DOE; contains references to scientific and technical research literature from the U.S. and many foreign countries, from 1974 to present.
- File 240: Paperchem; covers international patent and journal literature related to pulp and paper technology from 1967 to present.
- File 248: PIRA; indexes and abstracts the literature of the pulp and paper, packaging, printing, publishing, imaging and nonwovens industries from 1975 to present.
- File 315: Chemical Engineering and Biotechnology Abstracts; international coverage from 1970 to present.

- File 323: RAPRA; indexes and summarizes the literature of the rubber and plastics industries from 1972 to present.

#### *Targeted Companies for This Study*

A number of companies were identified and targeted for inclusion into the data search process to obtain historical data of in-plant motor related activity. These companies were compiled from the combined network of motor relationships of Advanced Energy and WSU, and other partners and affiliates of the two organizations. The criteria for selecting a target company included:

- Fairly balanced number from states (roughly proportional to funding)
- Concentrated in chemicals, forest products, & food processing industries
- Larger, multi-site companies likely to have more sophisticated engineering staff
- Companies where contacts pre-exist, or introductions could be obtained through a network of: previous customers, inquiries about motor services, associates of the Motor Resource Center Advisory Group, etc.

Companies that were targeted include Weyerhaeuser, BASF, DuPont, Milliken (chemicals group), Hoechst-Celanese (now KoSa), Cargill, etc. A contacts list of about 150 representatives of target companies was developed. About 50 of these companies were short listed for further action. Of that group, about 45 companies were contacted to solicit historical data on their motors.

#### *Revised Project Task*

We requested historical data from the industry for several months, but only one company responded with historical records that show MTBF. The search for data was therefore discontinued. Several companies, that were contacted and found to be documenting motor activity, tended to collect the information for inventory tracking purposes. It was observed that the specific data being requested was unavailable.

The project task was therefore revised in order to: analyze the data, articles and reports collected, summarize the qualitative and anecdotal information they contain, and to discuss issues and factors relating to motor reliability. This report also includes information related to issues that affect the reliability of repaired and new motors. Recommendations about best practices that would encourage the documentation of MTBF of new and rewind motors are also offered.

## **Motor Reliability Issues**

### *Reliability and Motor Failure*

Reliability is often defined as the capability of a product to perform its specified function in a given environment for a minimum period of time. The desire to have equipment, systems or processes perform when required is encountered in many situations and sometimes indirectly influences repair versus replace decisions. Many do not expect a new motor to fail shortly after installation, and would therefore be more accommodating to a failed rewind motor than a new motor. This kind of expectation intuitively attaches some value to motor reliability.

How long a motor should last before failure is still an open discussion. Some experts suggest a design life of about 15 to 20 years on motors. Many motors are known to last much longer than that, while others fail in the first few years of operation [25]. This is consistent with a bathtub curve in which the front end of the curve relates to manufacturing defects or failure due to neglect, and the other end relates to aging of the motors [26]. During the course of this project, one new motor failed on the test stand in the Advanced Energy lab. Another new motor delivered to one of the participants of this study failed shortly after installation. These two situations relate to the front end of the curve. Motors that have survived this defects period usually enjoy a period of normal performance until the aging period sets in.

Since all the motors in a given population do not fail at the same time, a mean time between failure covers an average time period between failure for motors in the population. Also, when motors are rewind several times (thereby extending their operating life) there can be issues regarding the total life-cycle of the motor and when it actually ends, or what kinds of failures are considered.

A motor failure, for the purposes of the STAC Motor Reliability Research, is considered to be the condition requiring removal of the motor from service to repair a fault (if the fault is not due to any system component other than the motor itself) that results in an inability to provide one or more fundamental functions, or as a necessary action to avoid the imminent loss of one or more fundamental functions.

### *Cost of Downtime (COD)*

Many industrial processes are driven by motors. One of the reasons motor reliability is important is the huge costs associated with lost production and downtime. The cost of downtime due to equipment failure is not always measured in monetary terms.

In evaluating the COD, failures that result in environmental or human safety are of highest priority. Next are failures that incur significant loss of production, and finally those that incur the cost replacing equipment.

For some applications, the damage done to the environment and the safety hazard that results from equipment failure cannot be easily quantified in monetary terms. The environmental and safety issues relating to equipment failure in these applications are a broad and difficult subject area that exists outside of the scope of this work, and are therefore not further discussed in this report.

In most industries the cost of the equipment that has failed is often much less than the cost of the downtime. The cost of downtime is therefore best quantified in terms of the monetary costs associated with production loss.

In recent discussions with industry contacts it was found that product downtime cost varies greatly, especially when considering whether the company has sold out capacity. The low end of downtime cost would be estimated at about \$4,000 per hour for building materials to about \$10,000 per hour for cement plants and to two million dollars per hour for the refining industry [2]. These numbers may serve as a useful range that many other specific applications and processes can fit into well.

In 2001, a management consultancy firm polled a number of companies online to determine the cost of downtime to business [11]. Of those companies that participated in the survey:

- 46 percent said each hour of downtime would cost their companies up to \$50K
- 28 percent said each hour would cost between \$51K and \$250K
- 18 percent said each hour would cost between \$251K and \$1M
- 8 percent said it would cost their companies more than \$1M per hour

A prior study on cost of downtime reported provided the following estimates [29]:

Table 3: Estimated Cost of Downtime (COD)	
Industry	Average COD per hour
Forest Products	\$7,000
Food Processing	\$30,000
Petroleum and Chemical	\$87,000
Metal Casting	\$100,000
Automotive	\$200,000

These numbers vary significantly from industry to industry and the methods of calculating them are not known and may in fact be questionable. It also appears that some numbers are presumably high but the conclusion to be drawn from them is that unplanned downtime due to equipment failure can be very expensive.

#### *Data Received from Industry*

One participant company in the manufacturing industry (referred to as Company A) submitted a summary of actual plant historical data from their operations. The data covered a period from 1995 to 2004. A summary of the data from Company A is as follows:

- Maintenance histories on a total of 5,880 repaired motors
- An average mean time between failure of 8.9 years based on 3,730 new motor installations
- Average annual operating hours of 5,200

#### *Previous Related Studies*

Motor reliability issues have been discussed from both motor design and motor operations perspectives. At the design level, reliability comparisons between standard and energy efficient induction motors have been carried out, considering design differences, performance tradeoffs, reported failure differences and testing [6]. The study concluded that the transition towards higher efficiency levels need not compromise motor performance or efficiency. Another published paper has debunked myths and complaints associated with the reliability differences between standard and energy efficient motors [23]. These publications indicate that users of motors sometimes have a different view of their performance than manufacturers. Most people agree that from the operations standpoint, motors fail mainly for mechanical reasons.



The IEEE subcommittee, Power System Reliability, carried out another study relating to motor reliability in 1985 and updated it in 1998 [28]. This study related to large motors (>200 Hp) in industrial and commercial installations. The Electric Power Research Institute (EPRI) also carried out a study on the reliability of motors operating primarily in power plants.

Although all these studies relate to different motor populations, types and ratings, their basic findings also confirm that bearing faults are predominate, followed by winding faults.

One other published set of data relating to motor reliability was from a study by Weyerhaeuser, one of the largest forest products companies in the world [17]. With about 57,000 motors in operation and 30,000 in inventory, the company found it prudent to have a motor management policy in place. This policy covers motor specifications as well as repair versus replace decisions aimed at reducing downtime.

The study's findings are:

- Many motors continue operating in the mill for 15 years or more
- 50 percent of new motors fail in seven years
- 50 percent of rewinds last only 3.5 years
- Practice has been to rewind if less than 10 years old
- Replace failed motors with new motor after 10 to 15 years' service
- Replace failed motors 50Hp or less
- Evaluate motors 60Hp or larger that fail for repair versus replacement using MM+
- Motor repairs should follow a specific written motor repair and rewind specification

A spreadsheet economic model was created to assess the value of new versus repaired motors for a typical industrial establishment using 7½ and 15 years MTBF for repaired and new motors, respectively. The other assumptions used in the model include: \$5,000 for cost of lost production per occurrence and 4 man hours to replace a failed motor at a labor cost of \$40 per hour.

The reliability premium of new versus replaced motors is calculated as the annualized net present value of the investment over the life of the motors, in this case 15 years. The cost of lost production was increased to \$20,000 to include industries with very critical motors and high cost of downtime.

Table 4: Reliability Premium of New Versus Rewound Motors		
HP	Cost of Lost Production / Event	
	\$5,000	\$20,000
50	\$312	\$1232
75	\$300	\$1221
100	\$279	\$1199
150	\$202	\$1123
200	\$184	\$1104

As shown in Table 2, for a plant with a population of about 100 repaired 50Hp motors versus 100 replaced 50Hp motors, the 100 repaired motors would cost about \$31,200 per year more to operate. In other words, a new motor will provide a reliability premium of \$312 per year as compared to a repaired motor. With a \$20,000 downtime cost, the premium is about \$1,232. This calculation is for reliability benefits only and does not include the efficiency benefits of new motors. The spreadsheet and assumptions for this calculation are attached as Appendix VI.

### Conclusion

After an extensive literature research and contact with almost 150 industrial facilities, we found only one industrial facility that could provide MTBF motor data and that was only for new motor installations. Some technical papers addressed reliability data for motors, but only for utilities, large petroleum refineries or offshore oil rigs, and they included only motors of 200Hp or larger. Other information available in technical papers and articles is anecdotal and did not meet the criteria for data to determine MTBF for new or repaired motors.

Some sources were found that provided insight into the costs of downtime of production machinery resulting from an unexpected motor failure. This information described a very broad range for the costs of production downtime that varied by industry type and process. However, if applied by industry and process and combined with MTBF data for new and repaired motors, it would have enabled development of the economic metrics to include in repair versus replace decisions.

Given the lack of motor tracking information from industrial facilities, it is not possible to develop a representative MTBF for new or repaired industrial motors. We are, therefore, unable to refine the economic evaluation of the repair versus replace decision to accommodate possible differences in motor reliability to meet the objectives of this project phase.

This report demonstrates there is a premium for reliability of motors. Future best practice in industrial motor management could provide the MTBF data needed to make the repair versus replace decision reflect the true economic picture.

Facilities that have a significant interest in managing their motors should establish and maintain a motor management policy. A significant part of a good policy includes tracking motors throughout their life in the facility, from initial purchase to final disposal. Best practices motor life tracking should include all dates associated with any status change in the motor, including installations, failures, repairs, etc, and operating hours. In addition, an effective policy should attempt to determine and document the root cause of any motor failure. These records will enable a determination of average MTBF for new and repaired motors so that the economics of reliability can be included in their repair versus replace evaluations. This will provide significant improvement in reducing motor energy use per unit of production and reduced downtime of production equipment due to motor failures.

All efforts to promote good motor management practices in industry as partially described above will benefit facilities by reducing energy use and improving motor reliability, thus reducing downtime and production costs. These benefits extend to the U.S. industrial base and the country as a whole by improving our ability to compete with off shore industry and retain U.S. manufacturing jobs.

## **ADDENDUM**

Reliability investigation subcommittee members:

- Bruce Benkhart, Director of Industrial programs, Applied Proactive Technologies
- John Malinowski, Marketing AC and DC motors, Baldor
- Dick Nailen, Technical Editor, Barks Publications
- Daryl Cox, Oak Ridge National Lab
- Gil McCoy P.E., Energy Systems Engineer, Washington State University Energy Program
- Johnny Douglass P.E., Senior Engineer, Industrial, Washington State University Energy Program

## Phase III — Horsepower Breakpoint Curve Update

### Introduction

Updating the *Horsepower Bulletin* covers all the activities associated with updating the text and developing horsepower breakpoint curves. Horsepower breakpoint curves are a set of curves that allow one to quickly approximate the motor horsepower above which you should repair the motor and below which you should buy a new motor as a replacement. This concept is considered to be one of the most widely used motor management methods.

The horsepower breakpoint concept was the main focus of the *Horsepower Bulletin* that was created by Advanced Energy for the DOE in 1991 and updated in 1995. It is still distributed by the DOE through the Industrial Technologies Program Clearinghouse. The *Horsepower Bulletin* currently being distributed by the Industrial Technologies Program Clearinghouse contains horsepower breakpoint curves that were generated with data that is now 10 years old. By using the curves in the *Horsepower Bulletin*, a facility could decide beforehand which motors in the facility should be repaired and which ones should be replaced with a new energy efficient motor. This helps eliminate a rush decision that often can cost the company thousands of dollars in operating cost until the next time that motor fails.

Experience indicates that a majority of industrial facilities are still using this horsepower breakpoint concept, and for most this is the only motor management tool regularly used [33]. While the concept is still valid, it has been seen that the breakpoint selection is generally based on old data that gives misleading or outdated results. Therefore, the two main goals for this phase of the project were to update the curves for a revision of the *Horsepower Bulletin* and to develop an online tool so users can create their own horsepower breakpoint curves.

The process of creating new horsepower breakpoint curves began with a review of the assumptions used in creating the original curves included in the 1995 revision of the *Horsepower Bulletin*. The review consisted of determining whether the assumptions were still valid and whether the assumptions used have been proven to be correct. Below are the assumptions and the conclusions that were reached for each one during the review.

#### 1995 Horsepower Bulletin Assumptions

1. Motors operate at 75 percent load.

The review of this assumption determined that it was no longer needed due to allowing users to create their own horsepower breakpoints online and select the operating load.

2. Efficiency of replacement energy efficient motors (EEM's) is the average of EEM's in MotorMaster (V2.1).

This assumption was changed so that the assumed efficiency is the average of the energy efficient motors in MotorMaster+ 4.0 [21]. The NEMA Premium™ level motors were also taken from MotorMaster+ 4.0 and include the average of all motors with nameplate efficiency greater than or equal to the NEMA Premium™ standard. Note that by selecting the nameplate efficiency we are introducing some error because efficiency changes with load.

3. Repaired standard motor efficiency is 5.3 points below new EEM efficiency (Advanced Energy Motor Test Lab data, June 1995).

This assumption was revised because the efficiency difference from 1Hp to 200Hp is not constant. As motors get larger they have to be more efficient to prevent them from over heating themselves. The efficiency difference for lower horsepower motors may be 5.3 percent or more, but at 100Hp, 200Hp and above they have to be more efficient so you will not have a 5.3 percent point difference in efficiency between a motor that is currently running and a new motor. The new assumption that is used compares efficiencies in MM+ 4.0. MM+ 4.0 has default values that represent the average of all motors that fit the definition on NEMA Premium™ and EPCA Energy Efficient. MotorMaster+ 4.0 also has a default for motors with unknown nameplate efficiencies. This default is used for old motors that are not energy efficient. By comparing the efficiencies in the old motors default to the NEMA Premium™ and EPCA Energy Efficient default, an efficiency difference that varies with horsepower results.

Data Sources:

- Compare Defaults Worksheet (EFF\_level 2), MotorMaster+ 4.0, 4-20-05.
- Compare Defaults Worksheet (EFF\_level 1), MotorMaster+ 4.0, 4-20-05.
- Efficiencies Worksheet (EFF\_level 1), MotorMaster+ 4.0, 4-20-05, plus NEMA EE min for 250-500 Hp from NEMA MG1 2002. Data was added from NEMA MG1 because MotorMaster+ 4.0 does not include data above 200 Horsepower in the defaults.

4. Rewind of an EEM is assumed to result in a one percent efficiency reduction (from BC Hydro and Ontario Hydro studies).

This assumption was removed because the efficiency difference was defined by the default tables in Assumption 3.

5. New EEM costs are average list price for EEM's from MM+ 4.0 times a 0.6 multiplier (40 percent discount).

This assumption is now being covered with a selection box that allows the user to select the discount percentage that they receive on motors. The prices that are being used also come from the same MotorMaster+ 4.0 Defaults listed in Assumption 3.

6. Repair costs from Vaughen's Price Guide 1992 for random wound AC TEFC motors including bearing replacement.

This assumption is still valid. The price data has been updated to Vaughen's Price Guide 2005 [37].

7. Repair versus replace breakpoints use two year simple payback for 1800RPM or 3600RPM.

The payback period for the online tool is a user input, so this assumption is not fixed. The new online tool has been expanded to include 1200RPM motors as well.

An unstated assumption that was included in text on the graph but not in the assumptions, was the enclosure of the motor had to be totally enclosed fan cooled (TEFC). The new online tools allow you to select between open drip proof (ODP) and TEFC enclosures.

### Data Collection

After the review of the assumptions, the next step was to gather all the data necessary to build the new horsepower breakpoint curves. As included above, the two sources of data were MotorMaster+ 4.0, 4-20-05 and Vaughen's Price Guide 2005. From of these two sources the following data was collected.

Table 5: Horsepower Breakpoint Curve Data Sources		
No.	Data	Source
1	Average Efficiency for NEMA Premium™ Motor	Compare Defaults Worksheet (EFF_level 2), MotorMaster 4.0, 4-20-05
2	Average Cost of NEMA Premium™ Motor	Compare Defaults Worksheet (EFF_level 2), MotorMaster 4.0, 4-20-05
3	Repair Cost for NEMA Premium™ Motor	Vaughen's Price Guide 2005
4	Average Efficiency for EPCA (Energy Efficient) motor	Compare Defaults Worksheet (EFF_level 1), MotorMaster 4.0, 4-20-05
5	Average Cost of EPCA (Energy Efficient) motor	Compare Defaults Worksheet (EFF_level 1), MotorMaster 4.0, 4-20-05
6	Repair Cost of EPCA (Energy Efficient) motor	Vaughen's Price Guide 2005.

7	Old Motor Efficiency for 1 -500 Horsepower	Efficiencies Worksheet (EFF_level 1), MotorMaster 4.0, 4-20-05, plus NEMA EE min for 250-500 Hp from NEMA MG1 2002
8	Efficiency difference between NEMA Premium™ and an old motor	Compare No. 1 and No. 7
9	Efficiency difference between NEMA Premium™ and EPCA (Energy Efficient) motor	Compare No. 1 and No. 4
10	Efficiency difference between EPCA (Energy Efficient) motor and an old motor	Compare No. 4 and No. 7

### Development of Horsepower Breakpoint Curves and Modeling Data

Once all data was gathered it was sorted and cut into sections based on the enclosure type (ODP and TEFC) and the motor's synchronous speed (1200RPM, 1800RPM and 3600RPM). By sorting the data, curves based on user inputs were developed. Along with enclosure and motor speed, other user inputs or variables that need to be specified are the cost paid for each kilowatt-hour, the percentage of the list price paid, the operating load of the motor and the length of time the investment could be paid back. All of these variables are selections that can be made by the user to generate a horsepower breakpoint curve that is unique to the facility.

The formula below can be used to calculate the number of hours per year that the motor needs to operate to recover the investment of purchasing a new motor instead of repairing the currently operating motor.

$$HPY = \frac{DF[NC(HP)] - RC(HP)}{N \cdot LF \cdot P \cdot PC \cdot \left( \frac{1}{\eta_{Old}} - \frac{1}{\eta_{New}} \right)}$$

Where HPY = hours per year (h), DF = discount factor, NC(HP) = new cost of the motor as a function of Horsepower (\$), RC(HP) = rewind cost of the motor as a function of horsepower (\$), N = desired payback period, LF = load factor (%), P = power (kW), PC = power cost (\$/kWh),  $\eta_{Old}$  = efficiency old motor,  $\eta_{New}$  = efficiency new motor.

Figure 8: Example of a Horsepower Breakpoint Curve

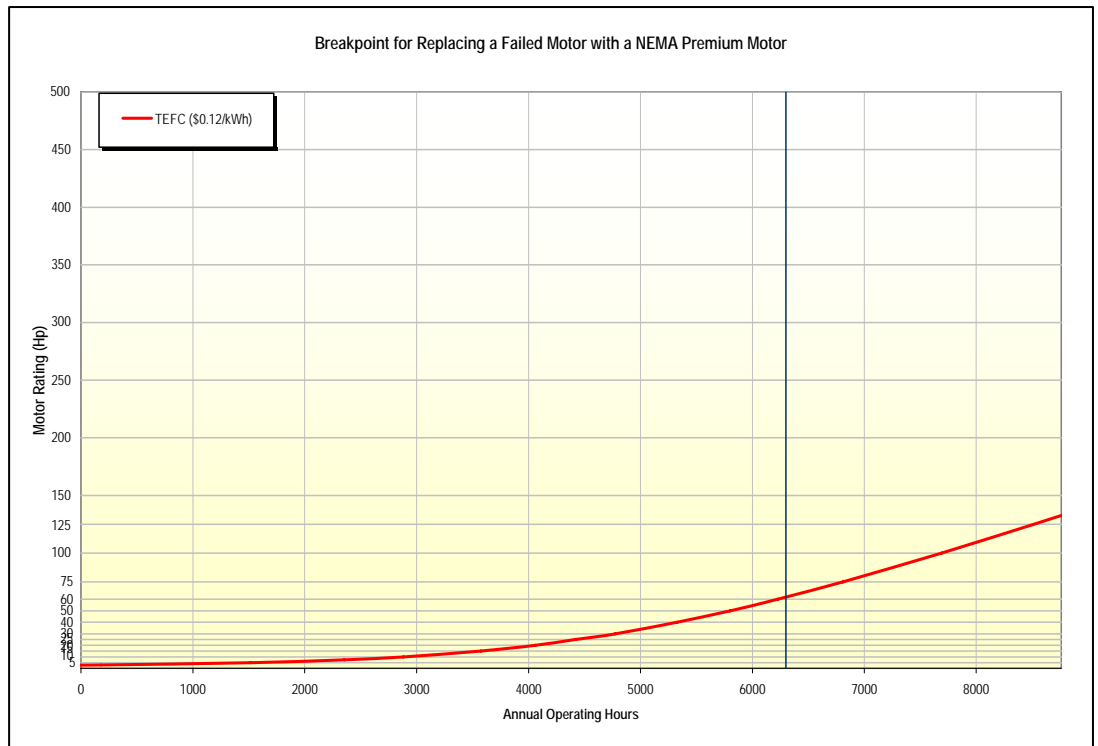

Plotting hours on the x axis and horsepower on the y axis gives a curve that allows the user to determine the size (in horsepower) that meets the required payback period. To determine the horsepower breakpoint, find the hours per year that this motor operates on the x axis and follow that up to the curve. From the curve travel horizontal over to the y axis.

Wherever you cross the y axis is the horsepower breakpoint. That size of motor and below will meet the financial investment payback requirement. For example, if a facility operates two shifts a year (6,240 hours), pays \$0.12 per kWh, receives a 40 percent discount off list price for a new motor and the enclosure is TEFC, the horsepower breakpoint curve would look like Figure 8. In Figure 8, a vertical line has been placed on 6,240 hours. Where this line intersects the horsepower breakpoint curve is the facility horsepower breakpoint. For this example the intersection occurs at 60 horsepower, the horsepower breakpoint for the facility.

Horsepower breakpoint curves were drawn using the actual data, but the graphs were very difficult to understand because the new motor cost per horsepower (list price divided by motor horsepower), the cost per horsepower for rewind, and the efficiency difference per horsepower are not linear. The nonlinearity of these inputs caused the graphs to bend and turn, which could provide multiple horsepower breakpoints for each set of inputs. A primary goal of this effort is to make the output easy to understand so that plant personnel will take



action. To accomplish this, either the input data needed to be smoothed or the output needed to be smoothed. Although this compromises the accuracy slightly in some situations, it was necessary to achieve simplicity and to get the desired behavior from motor users.

**Figure 9: Comparison of Data Models**

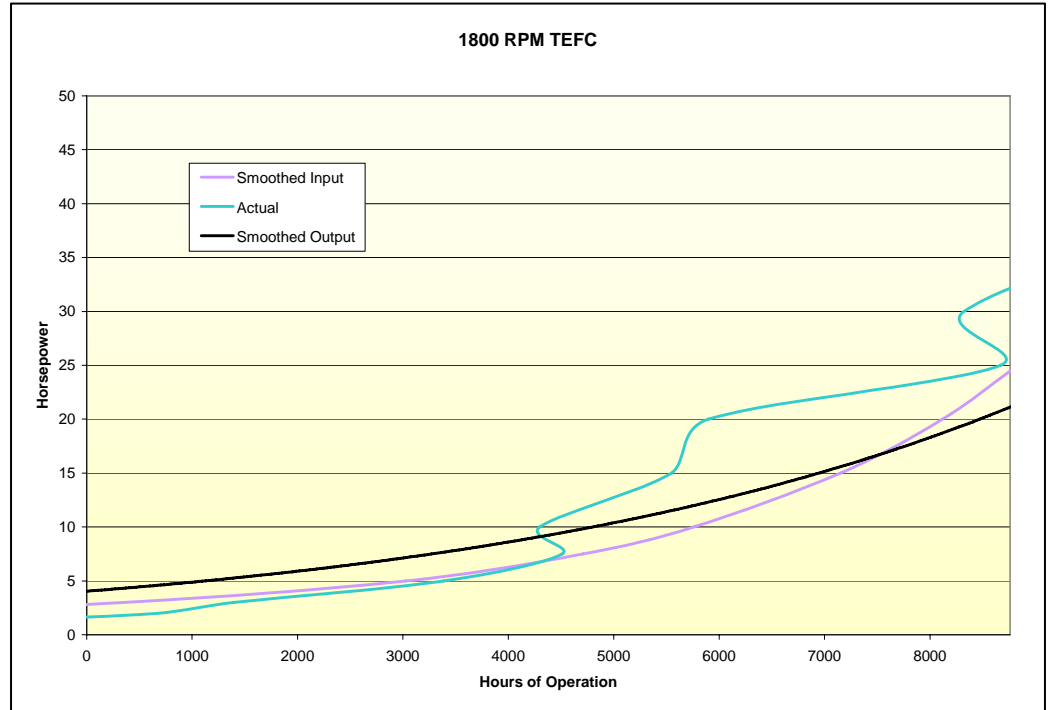

After reviewing the pros and cons of smoothing the input versus smoothing the output, smoothing the input data was chosen. Figure 9 shows the modeling of both the input and the output, and demonstrates how modeling the input during the operating hours of zero to 8,760 is a better approximation of the real data.

Figure 9 also illustrates why using the actual data without smoothing is not the best option. If a facility operated 8,500 hours per year, what would the horsepower breakpoint be for that facility, 25Hp, 27Hp or 32Hp? This confusion might paralyze motor users into inaction.

### **Development of Online Horsepower Breakpoint Curves**

Once the assumptions and the techniques for smoothing were determined for the horsepower breakpoint curve, an online tool was developed. The online tool is available at [www.advancedenergy.org/motors\\_and\\_drives/horsepower\\_breakpoint/tool](http://www.advancedenergy.org/motors_and_drives/horsepower_breakpoint/tool). The online tool asks for user inputs to produce customized breakpoint curves for the facility. The inputs used by the tool are motor enclosure type, motor synchronous speed, percentage of list price paid for new motors, power cost, payback period required for investments, load factor

of the motor and type of comparison the user wants to run. The tool can run comparisons between:

- a) New NEMA Premium™ motors and the replacement of old motors
- b) New NEMA Premium™ motors and new EPCA (Energy Efficient) motors
- c) New EPCA (Energy Efficient) motors and old motors

Figure 10 is a screen shot of the online tool. This screen shot shows the user selected a TEFC enclosure and 1800RPM. The percentage of list price the user pays is 75 percent, the cost of electricity is \$.05 per kWh, the investment needs to be paid back within two years and the average motor in the facility is operating at 75 percent of its full load. Finally, the user evaluates replacing old motors with NEMA Premium™ motors.

The output of the tool is a visual reference telling the user when they should repair or replace the motor based on the number of hours the motor is operating. In this example, if the motor in question operates 7,000 hours per year and if it is above 10Hp, it should be repaired and if it is below 10Hp it should be replaced with a new NEMA Premium™ motor. On the other hand, if a motor 5Hp and under fails, it should be replaced no matter how many hours it operates.

To help users understand the horsepower breakpoint curves and how to use them in their facility and motor management strategies, the *Horsepower Bulletin* has been updated to include more text regarding motor management and horsepower breakpoint curves. Along with updating the *Horsepower Bulletin* text, the same approach for an introductory page is being used for the online tool. By the time users get to point of inputting information about their facility, they will have a good understanding of the importance of motor management and how to get started in their facility.

Figure 10: Screen Shot of Online Horsepower Breakpoint Tool

### Economics of Motor Repair vs. Replacement

Inputs		Assumptions
Enclosure	TEFC	<ul style="list-style-type: none"> <li>Efficiencies and List Price taken from Motor Master 2004</li> <li>Rewind cost taken from Vaughen's Price Guide, 2005</li> <li>Replacement of energy efficient with NEMA Premium</li> </ul>
Speed	1800	
% List	75%	
Pwr Cost (\$/kWh)	<input type="text" value="0.05"/>	
Payback	2	
Load Factor	75%	
Comparison	NEMA Premium compared to Motor Rewindin	
<input type="button" value="Compare"/> <input type="button" value="Reset"/>		Definitions
		<ul style="list-style-type: none"> <li><b>Power Cost</b> - price of power in \$/kWh</li> <li><b>List Price</b> - full price in motor catalogs</li> <li><b>Load Factor</b> - average percent of full load the motor operates</li> <li><b>Payback period</b> - number of years over which the motor should</li> </ul>

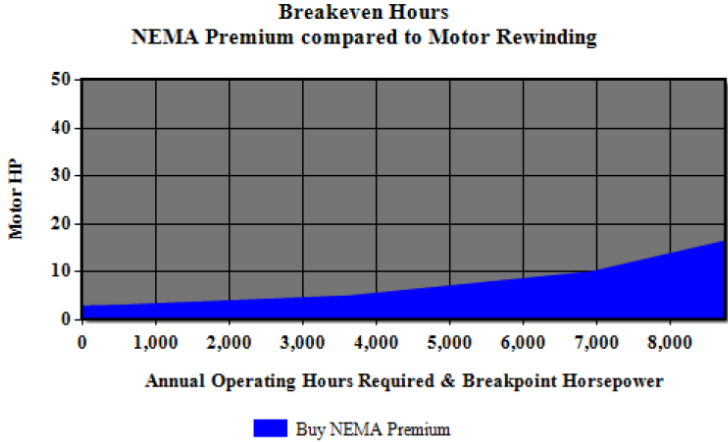

**Updated Horsepower Bulletin**

The original text used in the 1991 and 1995 *Horsepower Bulletin* focused on providing the reader with information about basic motor management policy. The document did not do a good job of tying together all the steps of motor management together to form a policy that is useable in industry. Along with the basic information the document included only energy efficient motors that were defined by the Energy Policy Act of 1992.

The *Horsepower Bulletin* introduced horsepower breakpoints as a way to make decisions regarding motors before they failed and caused a process shutdown. The breakpoints in the bulletin were a fixed set of cost per kilowatt-hour lines that a user could use to determine their facility horsepower breakpoint based on the facility's operating hours per year. Having this tool was a big step in the motor management world. The ability to make a decision on a motor before it failed allowed facilities to determine the action that needed to be taken for

each motor in the facility before it failed. Allowing facilities to make these decisions ahead of time made it possible for facilities to have a plan for motor failure instead of panic during a failure. Without a plan, the quickest action for a facility facing a motor failure was to repair. If repair was a bad decision for that particular motor, the facility was stuck with that decision for the next five to 10 years before the motor failed again.

The revised *Horsepower Bulletin* takes the same basic approach, but ties everything together into a how-to guide for basic motor management. The revised *Horsepower Bulletin* provides more background on why a facility should consider improving all areas of motor management from purchasing to repair versus replace decisions. It focuses more on the life-cycle cost of a motor and why that should be considered when purchasing motors. Like the previous version of the bulletin, the new one encourages planned replacements instead of the approach that encourages the quickest thing possible solution.

Along with more background information, the new *Horsepower Bulletin* includes an update of efficiencies to include NEMA Premium™ motors and how they should be included in all future motor management decisions. As mentioned previously, NEMA Premium™ motors are also included in the new horsepower breakpoint curves. Instead of trying to use one graph to provide all users with a horsepower breakpoint, an example was created that teaches users how to use the curves and how they can create their customized curves by going to the online tool.

Besides including examples of how the horsepower breakpoint curves fit into motor management, the revised *Horsepower Bulletin* provides a streamlined decision tree for fitting the curves into the decision making process. This streamlined decision tree covers when motors should be repaired and when motors should be replaced. It gives the user a step-by-step process for determining whether the motor should be repaired or replaced with a new motor. It covers replacement with NEMA Premium™ and replacement with energy efficient motors. This decision tree was designed to make it easier for companies to do motor management.

Based on Advanced Energy's experience of visiting 50 plus facilities each year and its relationships with companies in the southeast United States, it was concluded that motor management is still being done without preparation and planning. By revising the bulletin, it is hoped that facilities will be more proactive about motor management and motor decisions when faced with the repair versus replace decision.

## Future Improvements

The customizable online horsepower breakpoint curves are a great first step, but there is more work to be done. The next step would be to add other enclosures, such as the NEMA 841. This would add specialized motors that have higher initial cost, but have the same efficiencies as the NEMA Premium™ motors. Facilities are using NEMA 841 as replacements now, but by using the online horsepower breakpoint tool they would understand the economics of these replacements.

Another update would be the adjustment of the efficiencies of motors based on the motor load. Motor efficiency varies as the load on the motor changes. If the efficiency of three-phase induction motors is plotted versus the operating load, the resulting graph would be a curve. The peak point of the curve is usually between 75 and 100 percent load. If the motor is not operating between 75 and 100 percent load, the efficiency drops off. With older motors, the rate at which the efficiency drops off is usually much higher than the new energy efficient and NEMA Premium™ motors. Because of this, there is more of an efficiency improvement for replacing an older motor with an energy efficient motor or NEMA Premium™ motor.

The final recommendation for improvement will be the inclusion of reliability data. This would increase the benefit of replacing an old motor with a new motor. Currently, the economics of motor reliability are still being constructed, and not enough firm data exists to add this to the present *Horsepower Bulletin*. It is hoped that future work can provide the information needed to add reliability to the repair versus replace decision. If the *Horsepower Bulletin* continues to receive a major update every 10 years, at that point the inclusion of the benefits of reliability in the cost structure of motor replacement may be included.

## Conclusion

Phase III of Achieving More with Less: Efficiency and Economics of Motor Decision Tools focused on updating and improving the *Horsepower Bulletin* and especially the horsepower breakpoint curves. Based on new price, rewind cost and efficiency data, the horsepower breakpoint curves look very different than those included in the 1995 version of the *Horsepower Bulletin*. The new horsepower breakpoint curves included in the revised *Horsepower Bulletin* can be created online through an interactive tool located at [www.advancedenergy.org/motors\\_and\\_drives/horsepower\\_breakpoint/tool](http://www.advancedenergy.org/motors_and_drives/horsepower_breakpoint/tool). The revised *Horsepower Bulletin* now serves more as a how-to guide for motor management instead of serving as an informational document.

## Phase IV — Dissemination of Results

The goal of this project was to provide credible evidence to support or improve the assumptions made by many of the motor decision tools used by industry. In order to best achieve this goal, the project was split into four major tasks to specifically address the economics currently being used: 100 Motor Study, Economics of Motor Reliability, Horsepower Breakpoint Curve Update and Dissemination of Results. This section of the report focuses on the dissemination phase of the project.

The 100 Motor Study was the largest and most complex task of the four. The goal for this task was to better clarify operating efficiencies of older motors (pre-EPCA) operating in the field. Almost every motor decision tool uses the same calculation method requiring the user to start with efficiency obtained either from the nameplate or from previously established tables if nothing is on the nameplate. Many variables affect a motor's efficiency over its useful life. Using the number on the nameplate or from a table can be misleading if used as the basis for making a repair or replace decision. It does not allow the decisionmaker to base action on evidence of the actual motor's efficiency. Accurately testing each motor before making a decision is not practical or economical, resulting in assumptions that are forcibly made. This study encourages informed decisions by providing data that did not previously exist.

The 100 Motor Study continues to receive the most attention of the four project tasks from external stakeholders in the motor market, including those that promote the use of motor decision tools. Consequently, the bulk of our dissemination efforts are focused in this area. Below is a list of discussions of project results to date and two that will happen after the due date of this final report.

- March 7, 2005 — Kitt Butler presented 100 Motor Study results to date to the Motor Decisions Matter (MDM) group in Chicago, Ill. MDM is an awareness campaign focused on making small and medium sized business aware of the potential savings associated with sound motor management. Advanced Energy has been a sponsoring partner of this campaign for almost six years, and its employees serve on several of the committees, one of which is the MDM 1-2-3 process. This is a spreadsheet tool for making motor decisions. It also is designed for motor professionals to begin to open a dialogue with potential customers on the topic of motor management. It makes assumptions and calculations, but is not considered a tool for long-term motor management. Other sponsors include NEMA, DOE, EASA, EPA, various electric utilities, several motor manufacturers and a host of energy efficiency advocates similar to Advanced Energy. A complete listing of sponsors can be found at [www.motorsmatter.org](http://www.motorsmatter.org). The presentation given updated the group on

project progress to date and solicited input from the group for sites that could be considered for both the 100 Motor Study and the reliability study.

- May 23, 2005 — Nicole Kaufman made a presentation at the SPS Electric Automation America conference in Chicago, Ill. This is a conference that focuses primarily on the motor controls industry but attracts representatives from many of the major industrial motor manufacturers. The audience for this presentation included representatives from industry, other motor testing organizations and ABB. The presentation discussed the results of the 100 Motor Study to date. A conference paper with results to date was published in the proceedings and is attached in the appendix of this report.
- July 20, 2005 — Nicole Kaufman presented a poster at the American Council for an Energy Efficient Economy (ACEEE) summer study in West Point, N.Y. The poster is titled “A 100 Motor Study: Investigating pre-empt motors as a subset of the industrial motor population, preliminary results.” A copy of this presentation and the paper for the conference proceedings are included in the appendix section of this report. The following day at the same conference a meeting of the Motor Resource Center (MRC) Advisory Group was held to discuss the project in greater detail. The MRC is a voluntary group that works to improve the design, application and operation of motors and motor-driven systems by bringing together private and public organizations to make motor systems increasingly productive, reliable and efficient. The founding partners of the MRC are Advanced Energy and the Washington State University (WSU) Energy Program. The Advisory Group includes:

ACEEE, American Council for an Energy Efficient Economy

BASF

BJM Corporation

Brithinee Electric

California Energy Commission

CDA, Copper Development Association

Duke Power

DuPont

EASA, Electrical Apparatus Service Association

Electrical Apparatus Magazine

Emerson

GE

Kaman Industrial Technologies

Leeson

MEEA, Midwest Energy Efficiency Alliance

MotorUp

N.C. Electric Membership Corporation

NEEA, Northwest Energy Efficiency Alliance

NEEP, Northeast Energy Efficiency Partnerships

NEMA, National Electrical Manufacturers Association

North Carolina State University  
Northeast Utilities  
NYSERDA, New York State Energy Research & Development  
Authority  
Platts Research & Consulting, E Source Technology Assessment  
Group  
Progress Energy  
R.J. Reynolds  
Siemens  
TECO  
Toshiba  
U.S. Department of Energy  
University of Illinois  
WEG  
Weyerhaeuser  
Wisconsin Energy Office

- November 2005 — A conference paper written by Nicole Kaufman, presenting the results to date of the 100 Motor Study was published in the proceedings of the annual ASME International Mechanical Engineering Congress and Exposition. A copy of this paper can be found in the appendix section of this report.
- February 9, 2006 — A short report detailing the 100 Motor Study tested efficiencies to date was prepared for the NEMA Motor and Generator Section meeting held in Washington, D.C. The report was included in the meetings proceeding and the closed-door group allowed Kitt Butler and Nicole Kaufman 15 minutes via telephone to discuss it live.
- April 6, 2006 — Kitt Butler will present final project results to the MDM group at their annual meeting in Chicago.
- May 11, 2006 — Advanced Energy has been accepted to and has written a paper for the Industrial Energy Technology Conference in New Orleans. Nicole Kaufman's paper is titled "Replacing Motors, Counting Savings: Results from a 100 Motor Study". A copy of this paper can be found in the appendix section of this report.
- May 2007 — Advanced Energy has been invited to write a paper for and present results of this study at the IEEE Pulp and Paper International Committee meeting to take place in Williamsburg, Va.

In addition to these efforts, Advanced Energy has created a new online horsepower breakpoint analysis tool and *Horsepower Bulletin* for future dissemination to anyone interested in better motor management. The bulletin is an update to our original *Horsepower Bulletin* created in 1991 under contract with DOE. The online breakpoint tool includes all of the data discovered during the project and eliminates many of the



assumptions made in the original document (before test data on pre-EPCA motors and NEMA Premium motors was available to us). People accessing this tool can input their motor and facility metrics and get a much more accurate answer immediately. The online horsepower breakpoint curve is free to anyone and accessible by all at [www.advancedenergy.org/motors\\_and\\_drives/horespower\\_breakpoint/](http://www.advancedenergy.org/motors_and_drives/horespower_breakpoint/).

Case studies for each state in the project (California, New York and North Carolina) and each industry represented by the participating sites (chemical, food, wood/paper, cement, facilities, textile) were generated to show the energy savings achieved by replacing older motors with NEMA Premium™ motors. These case studies are attached and available in electronic form to be used by project participants in any manner they see fit. Each case study will also be available on Advanced Energy's website at [www.advancedenergy.org/motors\\_and\\_drives/knowledge\\_library/](http://www.advancedenergy.org/motors_and_drives/knowledge_library/).

Our dissemination goal is to build confidence and gain consensus among engineers and energy efficiency advocates so that our completed findings will be adopted into all of the motor decision tools currently in the marketplace. Fortunately, our partner in the MRC and one of the contractors on the project is the Washington State University Energy Program, which also manages the most widely recognized motor decision tool, MotorMaster+. Advanced Energy supports and is well connected to the Motor Decisions Matter Campaign, which uses another credible tool created by a cross section of industry stakeholders, MDM 1-2-3. As mentioned earlier, the data from this project will be used to improve the accuracy in our own motor decision tools. Advanced Energy will also make the results of this project available to anyone interested, and will directly approach others promoting the use of credible motor decision tools.

# Conclusions and Recommendation

1. Continue to use the standard motor management tools, such as MotorMaster+ 4.0, to estimate motor efficiency benefits with caution recognizing overestimated savings until a revision is made to the software.
2. Use life-cycle cost methods to estimate reliability improvements for new versus rewind motors *if that data is available*. However, we found it generally was not.
3. Track Mean Time Between Failures (MTBF) and root cause of motor failures. This should be part of standard motor management practice. In future years, this data can provide justification for motor purchase decisions that will allow reductions in life-cycle operating costs.

## References

1. A.D. Little, Inc. "Efficiency Standards in Commercial and Industrial Electric Motors and Equipment." Contract No. CO-04-50127-00, January 1976. Case #78537.
2. Boeteler, Rob. personal communication.
3. Boglietti, A., A. Cavagnino, M. Lazzari, and M. Pastorelli. "International Standards for the Induction Motor Efficiency Evaluation: A Critical Analysis of the Stray-Load Loss Determination." IEEE Transactions on Industry Applications, Vol. 40, No. 5, September / October 2004. Pages 1294-1301.
4. Bonnett, Austin H. "An Overview of How AC Induction Motor Performance Has Been Affected by the October 24, 1997, Implementation of the Energy Policy Act of 1992." IEEE Transactions on Industry Applications, Vol. 36, No. 1, January / February 2000.
5. Bonnet, Austin H. "Energy Policy Act of 1992: Review as it Pertains to AC Induction Motors." IEEE Paper No. PPIC 94-04, 1994.
6. Bonnet, Austin H. "Reliability Comparison between Standard and Energy Efficient Motors," IEEE Transactions on Industry Applications, Vol. 33, No. 1, January / February 1997.
7. Brethauer, Dale M., Richard L. Doughty, and Robert J. Puckett. "The Impact of Efficiency on the Economics of New Motor Purchase, Motor Repair, and Motor Replacement." IEEE Paper No. PCIC-93-05, 1993.
8. Colby, Roy S. and Denise L. Flora. "Measured Efficiency of High Efficiency and Standard Induction Motors." IEEE Paper 90/CH 2935-5/90/0000-018, 1990.
9. Darby, E. Steve. "Managing Electric Motors." IEEE Paper 0-7803-3297-0/96, 1996.
10. de Almeida, Anibal T. "Comparative Analysis of IEEE 112-B and IEC 34-2 Efficiency Testing Standards Using Stray Load Losses in Low-Voltage Three-Phase, Cage Induction Motors." IEEE Transactions on Industry Applications, Vol. 38, No. 2, March/April 2002. Pages 608-614.
11. Eagle Rock Alliance. "Online Survey Results; 2001 Cost of Downtime." [www.contingencyplanningresearch.com/2001%20Survey.pdf](http://www.contingencyplanningresearch.com/2001%20Survey.pdf).
12. El-Ibiary, Yehia. "An Accurate Low Cost Method for Determining Electric Motors' Efficiency for the Purpose of Plant Energy Management." IEEE Paper No. PCIC-2002-29, 2002.

13. Energy Information Administration. Manufacturing Energy Consumption Survey. Table N.11.3. Quantity of Purchased Electricity, Natural Gas, and Steam, 1998.  
[http://www.eia.doe.gov/emeu/mecs/mecs98/datatables/d98n11\\_3.htm](http://www.eia.doe.gov/emeu/mecs/mecs98/datatables/d98n11_3.htm).
14. Gray, Gerald and Walter Martiny. "Efficiency Testing of Medium Induction Motors: A Comment on IEEE Std 112-1991." IEEE Transactions on Energy Conversion, Vol. 11, No. 3, September 1996. Pages 495-499.
15. Guenther, Donald and Thomas Shearer. "An Economic Model for Purchasing, Owning, and Maintaining Induction Motors." IEEE Paper CH3142-7/92/0000-0051, 1992.
16. Hines, William W., Douglas C. Montgomery, David M. Goldsman, and Connie M. Borrer. Probability and Statistics in Engineering. 4th Edition. Danvers, MA: John Wiley and Sons, 2003.
17. Holmquist, John R. "Reasons for Using IEEE Standard 841-1994 Motors for the Forest Products Industry" IEEE PPIC Conference Record, 1998.
18. IEEE Standard 112-1996, "Standard Test Procedure for Polyphase Induction Motors and Generators," New York, Institute of Electrical and Electronic Engineers, 1997.
19. Kellum, Ziba. "The Energy Policy Act and its Effect on Industrial Motors." IEEE Paper 0-7803-4962-8/98, 1998.
20. Malinowski, John, Jim McCormick and Kevin Dunn. "Advances in Construction Techniques of AC Induction Motors: Preparation for Super-Premium Efficiency Levels." IEEE Paper No. PCIC-2003-22, 2003.
21. MotorMaster+ 4.0 User's Manual, U.S. Department of Energy and Washington State University Energy Program, 2003. 58-60.
22. Nadei, Steve, et al. "Energy Efficient Motor Systems: A Handbook on Technology, Programs, and Policy Opportunities." American Council for an Energy Efficient Economy, Washington, D.C., and Berkeley, CA, 1991.
23. Nailen, Richard L. "Are Energy Efficient Motors Reliable?" Electrical Apparatus, October 1998.
24. Nailen, Richard L. "Energy Efficient Motors—Myths vs. Reality." Textile, Fiber and Film Industry Technical Conference, 1993, IEEE 1993 Annual, 4-6 May 1993.
25. Nailen, Richard L. "How long should a motor last?"  
[http://www.brithinee.com/resources/How\\_Long.htm](http://www.brithinee.com/resources/How_Long.htm).
26. Nailen, Richard L. "Is a repaired motor less reliable?" Electrical Apparatus, January 2004.

27. National Electric Manufacturers Association, NEMA Standards Publication No. MG1-1998, Revision 2.
28. O'Donnel, P. "Report of Large Motor Reliability Study of Industrial and Commercial Installations (Parts I, II, III)", IEEE Transactions on Industry Applications Parts I & II, July / August 1986, pp. 852-872; Part III, January / February 1987, pp. 162- 168
29. Penrose, H.W. "Test Methods for Determining the Impact of Motor Condition on Motor Efficiency and Reliability." [www.alltestpro.com/pdf/Test%20Methods.pdf](http://www.alltestpro.com/pdf/Test%20Methods.pdf).
30. Pillay, Pragsen. "Factors to Consider in the Application of Energy Efficiency Motors." Proceedings of the IEEE International Symposium on Industrial Electronics, Vol. 1, 10-14 July 1995. Pages 99 – 109.
31. Pillay, Pragsen and Kelli A. Fendley. "The Contribution of Energy Efficient Motors to Demand and Energy Savings in the Petrochemical Industry." IEEE Transactions on Power Systems, Vol. 10, No. 2, May 1995.
32. Renier, B., K. Hameyer, and R. Belmans. "Comparison of standards for determining efficiency of three phase induction motors." IEEE Transactions on Energy Conversion, Vol. 14, No. 3, September 1999. Pages 512-517.
33. "State of the EASA Industry." Indian River Consulting Group, 2003.
34. Stroker, John J. "Higher Efficiency—What is the Real Cost?" IEEE Paper 0-7803-7254-9/02 2002.
35. U.S. Department of Energy. "Annual Energy Outlook through 2025." 2005.
36. U.S. Department of Energy. "United States Industrial Electric Motor Market Opportunity Assessment." 1998.
37. Vaughen's Motor and Pump Repair Price Guide, Ed. 2005, Vaughen's Price Publishing Co., Inc.

# Appendices

## Appendix I — Analysis

## Appendix II — 100 Motor Case Studies

- Motors in California
- Motors in New York
- Motors in North Carolina
- Motors in the Aggregate Industry
- Motors in the Chemical Industry
- Commercial Facility Motors
- Motors in the Food and Beverage Industry
- Motors in the Textile Industry
- Motors in the Wood Products Industry

## Appendix III — Updated *Horsepower Bulletin*

## Appendix IV — Report for the SPS Electric Automation America Conference, May 2005

## Appendix V — Report for the ASME International Mechanical Engineering Congress and Exposition, November 2005

## Appendix VI — Report for the Industrial Energy Technology Conference, May 2006

## Appendix VII — Reliability Economic Model

