

UC Berkeley

Faculty Research

Title

Structural Equation Modeling of Travel Choice Dynamics

Permalink

<https://escholarship.org/uc/item/3dj9x6wr>

Author

Golob, Thomas F.

Publication Date

1988-12-01



**Structural Equation Modeling of
Travel Choice Dynamics**

Thomas F. Golob

December 1988

Working Paper No. 4

**The University of California
Transportation Center**

University of California
Berkeley, CA 94720

**The University of California
Transportation Center**

The University of California Transportation Center (UCTC) is one of ten regional units mandated by Congress and established in Fall 1988 to support research, education, and training in surface transportation. The UC Center serves federal Region IX and is supported by matching grants from the U.S. Department of Transportation, the California State Department of Transportation (Caltrans), and the University.

Based on the Berkeley Campus, UCTC draws upon existing capabilities and resources of the Institutes of Transportation Studies at Berkeley, Davis, and Irvine; the Institute of Urban and Regional Development at Berkeley; the Graduate School of Architecture and Urban Planning at Los Angeles; and several academic departments at the Berkeley, Davis, Irvine, and Los Angeles campuses. Faculty and students on other University of California campuses may participate in

Center activities. Researchers at other universities within the region also have opportunities to collaborate on selected studies. Currently faculty at California State University, Long Beach, and at Arizona State University, Tempe, are active participants.

UCTC's educational and research programs are focused on strategic planning for improving metropolitan accessibility, with emphasis on the special conditions in Region IX. Particular attention is directed to strategies for using transportation as an instrument of economic development, while also accommodating to the region's persistent expansion and while maintaining and enhancing the quality of life there.

The Center distributes reports on its research in working papers, monographs, and in reprints of published articles. For a list of publications in print, write to the address below.



**University of California
Transportation Center**

108 Naval Architecture Building
Berkeley, California 94720
Tel: 415/643-7378
FAX: 415/643-5456

Authors of papers reporting on UCTC-sponsored research are solely responsible for their content. This research was supported by the U.S. Department of Transportation and the California State Department of Transportation, neither of which assumes liability for its content or use.

**Structural Equation Modeling
Of Travel Choice Dynamics**

Thomas F. Golob

Institute of Transportation Studies
University of California at Irvine

Working Paper No. 4

December 1988

The University of California Transportation Center
University of California at Berkeley

1. OBJECTIVES AND SCOPE

This research has two objectives. The first objective is to explore the use of the modeling tool called "latent structural equations" (structural equations with latent variables) in the general field of travel behavior analysis and the more specific field of dynamic analysis of travel behavior. The second objective is to apply a latent structural equation model in order to determine the causal relationships between income, car ownership, and mobility.

Many transportation researchers might be unfamiliar with latent structural equation modeling, which is also known as "latent structural analysis," "causal analysis," and "soft modeling." However, most researchers will be quite familiar with techniques that are special cases of latent structural equations: e.g., conventional multiple regression and simultaneous equations, path analysis, and (confirmatory) factor analysis. Furthermore, recent advances in estimation techniques have made it possible to incorporate discrete choice variables and other non-normal variables in structural equations models. Thus, probit choice models (binomial, ordered, and multinomial) can be incorporated within the general model framework.

The empirical analysis reported here involves dynamic travel demand data from the Dutch National Mobility Panel for the three years 1984 through 1986. All variables in the model, with the exception of income level in the first year, are endogenous: income is treated as an ordinal (four category) variable; car ownership is treated as either an ordinal (ordered probit) or a categorical (multinomial probit) choice variable; and mobility, in terms of car trips and public transport trips, is treated as two censored (tobit) continuous variables. The model fits the data well, but only scratches the surface of the potential of latent structural equation modeling with panel data. Some possible extensions are outlined.

The methodological discussion is not intended as a comprehensive overview of structural equation modeling with latent variables. Rather, the aim is to explore the technique in comparison to conventional methods of travel behavior analysis. Many extensive overviews are available, due to the popularity of the

technique in the fields of sociology and psychology, and more recently in marketing research. The technique as described here has been in use since the early 1970s, but, because of recent rapid developments, current overviews are more relevant to transportation researchers. Such overviews are provided by Bentler (1980), Bentler and Weeks (1985), Fornell and Larcker (1981), Hayduk (1987), and Jöreskog and Wold (1982), among others. In particular, Hayduk (1987) provides an extensive bibliography. Historical developments are reviewed in Bentler (1986) and Bielby and Hauser (1977).

The author is aware of three computer programs for latent structural equation modeling: LISREL (Jöreskog and Sörbom, 1984; 1987), EQS (Bentler, 1985), and LISCOMP (Muthén, 1987). Each program is based on a different approach to estimation and testing and each has its advantages and disadvantages. The three approaches are briefly reviewed in Section 6 on estimation methods. The application results presented here were obtained using the LISCOMP program. It is also possible to replicate the approaches of these programs by implementing several separate estimation procedures (e.g., maximum likelihood estimations of probit models and tobit models, and generalized least square and maximum likelihood estimations of simultaneous equations) in sequential and recursive order, but this is inefficient in view of the available comprehensive packages.

2. METHODOLOGY

2.1 Structural equation modeling

A structural equation (or, structural relationships) model is a specific type of simultaneous equation system in which the variables are divided into two sets--endogenous variables and exogenous variables--and each equation in the system represents the direct effect of one variable upon another variable. Thus, any structural equation system can be expressed as

$$y = \alpha + \Gamma x + \zeta \quad (1)$$

where y is a $(p \times 1)$ column vector of p endogenous (dependent) variables, x is an $(m \times 1)$ column vector of m exogenous (independent) variables, α is a $(p \times 1)$ vector of mean values (regression intercepts), ζ is

a $(p \times 1)$ vector of disturbances, \mathbf{B} is a $(p \times p)$ parameter matrix of regression coefficients for the equations directly relating the endogenous variables, and Γ is a $(p \times m)$ parameter matrix of regression coefficients for the equations relating the endogenous and exogenous variables. A necessary condition for identification of the simultaneous equation system is that the matrix $(\mathbf{I} - \mathbf{B})$ be nonsingular.

Each (β_{ij}) element in the \mathbf{B} parameter matrix represents the direct effect of endogenous variable y_j on endogenous variable y_i , and the main diagonal of \mathbf{B} is specified to contain only zeros. Similarly, each γ_{ij} element in the Γ matrix represents the direct effect of exogenous variable x_j on endogenous variable y_i . Consequently, there is a one-to-one correspondence between equation (1) system and a flow diagram in which there is a unidirectional arrow between each variable pair with nonzero elements in the \mathbf{B} and Γ matrices.

For example, a simple multiple regression with three independent and one dependent variables can be expressed in the notation of system (1) as

$$y_1 = \alpha_1 + \gamma_{11} x_1 + \gamma_{12} x_2 + \gamma_{13} x_3 + \zeta_1 \quad (2)$$

where $p = 1$ and $m = 3$; so y , α , and ζ are scalars, \mathbf{B} (1×1) is zero by definition, and Γ (1×3) has three parameter elements. The corresponding flow diagram is shown in Figure 1.

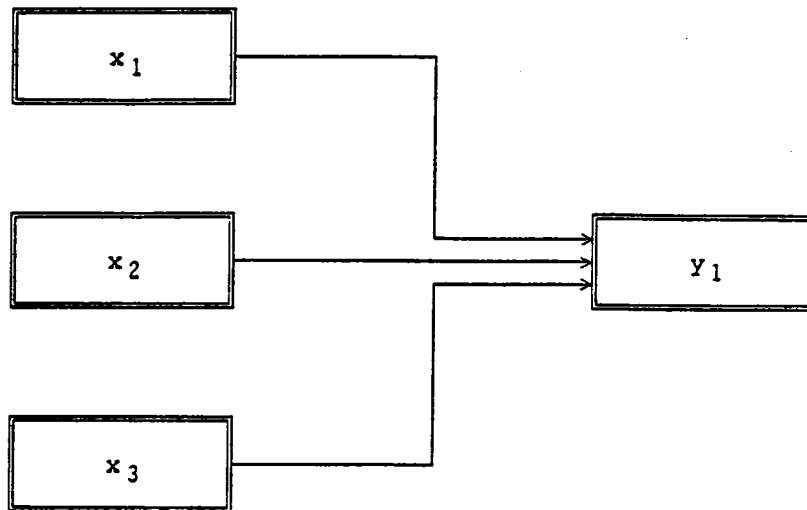

FIGURE 1

FLOW DIAGRAM OF A MULTIPLE REGRESSION MODEL INVOLVING THREE INDEPENDENT AND ONE DEPENDENT VARIABLE

However, very few substantive problems in travel behavior analysis involve only a single endogenous (dependent) variable. Certainly activity-based approaches encompass multiple variables indicating, for example, the satisfaction of different activities in spatial and temporal dimensions. Moreover, dynamic studies have focused on mobility levels, demand elasticities for various transport modes, and other travel behavior manifestations that are by definition multidimensional. The present analysis concerns the dynamic interrelations among four variables: income, car ownership, and trip-making by two modes (car and public transport). Clearly, the multiple regression structure of equation (2) and Figure 1 is inappropriate; there are multiple dependent variables in such a problem.

A possible model of the contemporaneous causal structure among the four variables in question follows Golob (1989): system (1) is specified with $p = 3$ endogenous variables ($y_1 =$ car ownership; $y_2 =$ car trip rate; and $y_3 =$ public transport trip rate) and $m = 1$ endogenous variable ($x_1 =$ income). It is postulated that income affects both car ownership and public transport trip-making, but not car trip-making; car trip-making is affected only by car ownership. Also, public transport trip-making is affected by both car ownership and car trip-making, as well as income. These causal relationships can be represented by equation system (1), with

$$\mathbf{B} = \begin{bmatrix} 0 & 0 & 0 \\ \beta_{21} & 0 & 0 \\ \beta_{31} & \beta_{32} & 0 \end{bmatrix} \quad (3a)$$

and

$$\mathbf{\Gamma} = \begin{bmatrix} \gamma_{11} \\ 0 \\ \gamma_{31} \end{bmatrix} \quad (3b)$$

There are five parameters in this system, represented by the nonzero elements in the \mathbf{B} and $\mathbf{\Gamma}$ matrices. This structural equation model is thus depicted unambiguously by the five arrows in the flow diagram of Figure 2.

Estimation of the \mathbf{B} and $\mathbf{\Gamma}$ parameters in a structural equation model such as (1)-(3a)-(3b) (Figure 2) is straightforward with conventional assumptions concerning the endogenous y variables and the covariances of the ζ disturbance terms. If multivariate normality is assumed for the distribution of the y

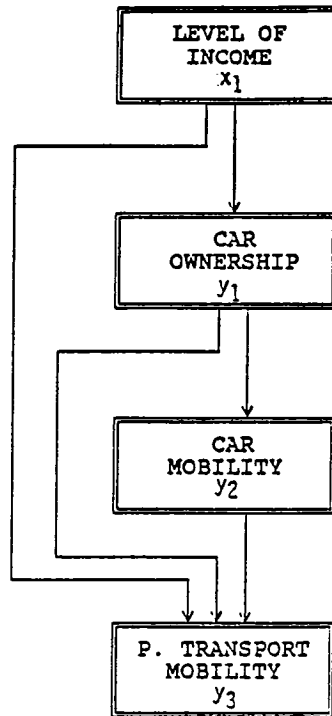

FIGURE 2

FLOW DIAGRAM OF A STRUCTURAL EQUATION MODEL INVOLVING ONE INDEPENDENT AND THREE DEPENDENT VARIABLES

variables conditional on the x variables, it is sufficient to consider only the first and second order moments

$$E(y | x) = (I - B)^{-1} \alpha + (I - B)^{-1} \Gamma x \quad (4)$$

and

$$\Sigma(y | x) = (I - B)^{-1} \psi (I - B)^{-1} \Gamma x \quad (5)$$

where E ($p \times 1$) and Σ ($p \times p$) are the first and second order moments, ψ ($p \times p$) is the second order moment matrix of the ζ disturbances, and it is assumed that ζ is uncorrelated with x . The second order moment matrices are typically variance-covariance matrices, but can also be correlations (variance-covariances of standardized variables).

For most analyses with a single population group, the mean vector is unconstrained and it is sufficient to consider the Σ model variance-covariance matrix in relation to the sample variance-covariance matrix S . The fitting function F for maximum-likelihood estimation of B and Γ is

$$F = 1n | \Sigma | + \text{trace}(S \Sigma^{-1}) - 1n | S | - (p + m) \quad (6)$$

and the fitting function for unweighted least squares is

$$F = 1/2 \text{ trace } [(S - \Sigma)^2]. \quad (7)$$

Unfortunately, such a straightforward approach to the specification and estimation of structural equation models is inappropriate for many problems in travel behavior modeling which involve y variables that are not continuous and normally distributed. This is true of car ownership, income measured in terms of ordinal categories, and even the trip rate variables in the present problem (the trip rate variables taking on only positive values, with spikes in the distributions at zero). Also, unique opportunities in analyzing panel data argue for extending the structural equation system (1) to accommodate more general disturbance term structures. Non-normal variables and other useful generalizations are accommodated by introducing nonlinear transformations and latent, or unobserved, variables into structural equations models.

2.2 Latent Variables

The usefulness of structural equation models can be greatly enhanced by introducing the concept of latent variables into the equation system. A latent variable is a theoretical construct that does not correspond exactly to an observed variable. The discrepancy between the theoretical construct and its observed indicator variable or variables might be due to inaccuracy in measurement or the inability to capture the concept through variables obtained from survey data. Whatever the source of the discrepancy, explicit recognition of measurement problems is critical in the development of improved behavioral models (Blalock, 1979; 1982). Structural equation models with latent variables (also known as "latent structure analysis" and "soft modeling") provide a means of integrating measurement concerns with the specification, estimation, and testing of causal hypotheses (Bohrstedt, 1983; Wold, 1982; Hayduk, 1987).

Latent variables are introduced by expanding system (1) into a system involving two submodels:

$$y = \nu + \Lambda \eta + \epsilon \quad (8a)$$

$$\eta = \alpha + \mathbf{B} \eta + \Gamma x + \zeta \quad (8b)$$

where η is a $(q \times 1)$ column vector of latent variable constructs, ν is a $(q \times 1)$ vector of latent variable expected values (measurement model intercepts), Λ is a $(q \times p)$ matrix of coefficients in the measurement model relating the latent variable constructs and the observed endogenous variables, and ϵ is a $(q \times 1)$

vector of measurement errors. The measurement submodel (8a) is also known as the inner relationships, while submodel (8b) is also known as the block structure (Wold, 1982). The entire system (8a) and (8b) is to be solved simultaneously.

It is also possible to introduce latent variable constructs for the exogenous x variables, and these are generally denoted as ζ variables. However, there is no loss in generality in disregarding these concepts in the present discussion. Statistical estimation problems arise from non-normal endogenous rather than exogenous variables, so the η endogenous constructs of system (8) are of utmost importance in travel behavior modeling. These latent variable constructs can serve as indicators for observed choice variables that are dichotomous, ordered polytomous, or censored continuous variables.

Latent variables with multiple observed variables (i.e., measurement submodels where p observed variables are summarized by $q < p$ latent constructs) are common in applications of latent structural equation modeling in the social sciences. A hypothetical model is given by system (8) with $p = 5$ endogenous variables, $q = 2$ latent variables, $m = 2$ exogenous variables, and

$$\Lambda = \begin{bmatrix} \lambda_{11} & 0 \\ \lambda_{21} & 0 \\ \lambda_{31} & \lambda_{32} \\ 0 & \lambda_{42} \\ 0 & \lambda_{52} \end{bmatrix} \quad (9a)$$

$$B = \begin{bmatrix} 0 & 0 \\ 0 & 0 \end{bmatrix} \quad (9b)$$

and

$$\Gamma = \begin{bmatrix} \gamma_{11} & 0 \\ \gamma_{21} & \gamma_{22} \end{bmatrix} \quad (9c)$$

This model is shown in the flow diagram of Figure 3. It could be a confirmatory factor analysis model with two factors (latent variables) representing five endogenous y variables, with factor scores being related to two exogenous x variables. Typically, the y variables would be attitudinal scales or test items, and the x variables would be sociodemographic variables (such as age, sex, income).

Even if there is a one-to-one correspondence between the latent variable constructs and the observed endogenous variables (i.e., when $p = q$ and the measurement Λ matrix has only nonzero main diagonal elements), the measurement submodel of a latent structural equations system can be important: If the

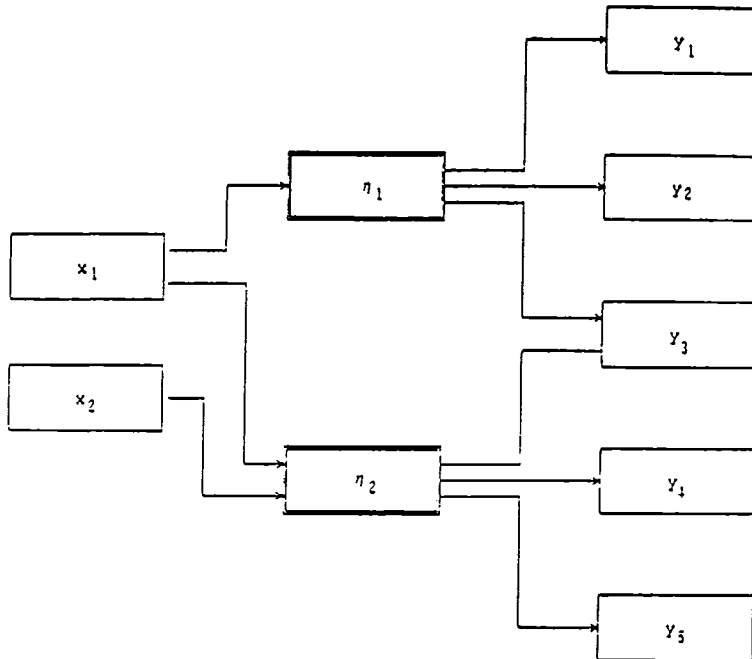

FIGURE 3

FLOW DIAGRAM OF A STRUCTURAL EQUATION MODEL INVOLVING TWO LATENT VARIABLES, TWO OBSERVED INDEPENDENT VARIABLES, AND FIVE OBSERVED ENDOGENOUS VARIABLES (A CONFIRMATORY FACTOR ANALYSIS WITH REGRESSOR VARIABLES)

continuous latent construct is indicated by an observed dichotomous, ordered polychotomous, or censored continuous observed variable, then the measurement model can capture nonlinear (e.g., probit or tobit) transformations. This generalization makes latent structural equation modeling a particularly appropriate tool for travel behavior analysis.

As an example of a nonlinear measurement model transformation structure, consider the model of system (1)-(3a)-(3b) and Figure 2, this time with all variables considered to be endogenous and with each latent construct indicated by a single (non-normal) observed variable. The resulting latent structural equation model is depicted in the flow diagram of Figure 4. The equations are specified by system (8) with

$$\Lambda = \begin{bmatrix} \lambda_{11} & 0 & 0 & 0 \\ 0 & \lambda_{22} & 0 & 0 \\ 0 & 0 & \lambda_{33} & 0 \\ 0 & 0 & 0 & \lambda_{44} \end{bmatrix} \quad (10a)$$

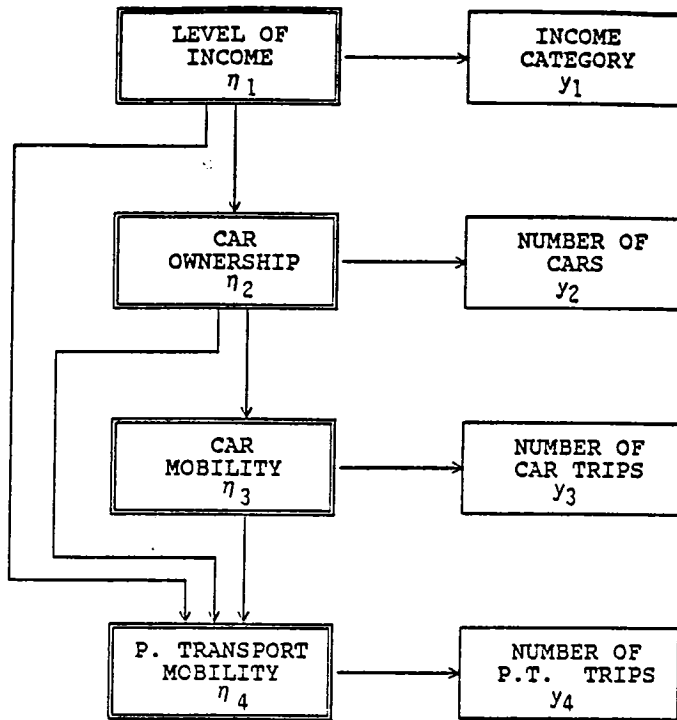

FIGURE 4

FLOW DIAGRAM OF A STRUCTURAL EQUATION MODEL WITH MEASUREMENT SUBMODEL INVOLVING FOUR LATENT ENDOGENOUS VARIABLES AND FOUR OBSERVED ENDOGENOUS VARIABLES

$$B = \begin{bmatrix} 0 & 0 & 0 & 0 \\ \beta_{21} & 0 & 0 & 0 \\ 0 & \beta_{32} & 0 & 0 \\ \beta_{41} & \beta_{42} & \beta_{43} & 0 \end{bmatrix} \quad (10b)$$

where $p = 4$ endogenous variables ($y_1 =$ income category; $y_2 =$ number of cars owned; $y_3 =$ car trips; and $y_4 =$ public transport trips); $q = 4$ latent variables ($\eta_1 =$ income level; $\eta_2 =$ car ownership or accessibility; $\eta_3 =$ car mobility; and $\eta_4 =$ public transport mobility); and $m = 0$ (no x variables). This model structure is the cross-sectional basis of the dynamic model discussed in Section 7, where the transformations underlying the measurement submodel are extended to be nonlinear, as described in the next section.

Estimation of the Λ , B , and Γ parameters in a latent structural equation model (8a)-(8b) is a direct extension of estimation of the structural equation model without the measurement submodel. The first and second order moments (4) and (5) of the structural equation model become, in the presence of the measurement submodel:

$$E(y | x) = \nu + \Lambda (I-B)^{-1} \alpha + \Lambda (I-B)^{-1} \Gamma x \quad (11)$$

and

$$\Sigma (y | x) = \Lambda (I-B)^{-1} \psi (I-B)^{-1} \Lambda' + \theta \quad (12)$$

where θ is the second order moment matrix of the ϵ measurement errors. The objective functions of the maximum likelihood and least squares solutions (6) and (7) are unchanged in terms of the expanded Σ function (12).

2.3 Non-Normal Choice Variables

Very few variables that are indicative of travel behavior decisions are continuous and normally distributed: Such variables tend to be dichotomous (e.g., whether to purchase a public transport season ticket or not, or whether to make a certain journey or not), polytomous (e.g., which of several modes to choose for a particular journey), ordered polytomous (e.g., how many cars to own), continuous, censored at zero (e.g., how many trips are made by a certain mode during a particular time period) or continuous, censored at both zero and an upper bound (e.g., time or distance traveled within a certain time interval, such as peak hours). Recent advances in latent structural equation modeling make it possible to consistently estimate systems containing endogenous (dependent) variables of any of these non-normal types.

Variables that are non-normally distributed can be accommodated within a latent structural equation model by adding an additional submodel that relates the noncontinuous, censored, or truncated observed variables to continuous indicator variables. In modeling travel choice, noncontinuous dichotomous and ordered polytomous variables are of utmost importance, as are variables censored with a lower bound of zero (e.g., trip rates or distances traveled).

The transformation from an observed ordered polytomous indicator variable y_i with c_i categories to an underlying continuous latent indicator variable y_i^* is given in terms of an unknown K threshold vector by

$$y_i = \begin{cases} c_i-1 & \text{if } k_{i, c_i-1} < y_i^* \\ c_i-2 & \text{if } k_{i, c_i-2} < y_i^* \leq k_{i, c_i-1} \\ \vdots & \\ 1 & \text{if } k_{i, 1} < y_i^* \leq k_{i, 2} \\ 0 & \text{if } y_i^* \leq k_{i, 1} \end{cases} \quad (13)$$

Dichotomous variables are a special case of (13) with $c_i = 2$.

For a continuous y_i observed indicator variable that is censored from below at the lower bound d_i , the transformation is given by

$$y_i = \begin{cases} d_i & \text{if } y_i^* - k_{i,0} \leq d_i \\ y_i^* - k_{i,0} & \text{if } y_i^* - k_{i,0} > d_i \end{cases} \quad (14)$$

(where the lower bound d_i is usually zero for endogenous travel behavior variables).

The thresholds $K_{i,j}$ ($j = 0$ or $J = 1, \dots, c_i - 1$) in transformations (13) and (14) are estimated so that the underlying latent continuous y_i^* variables are distributed multivariate normally. Transformation (13) is thus a probit model (binomial probit with $c_i = 2$, or ordered-response probit with $c_i > 2$). For the ordered-response probit model (or, simply the ordered probit model) developed by Aitchison and Silvey (1957) and Ashford (1959), equation (13) can be expressed as

$$\begin{aligned} P(y_i = j \mid x) &= P(k_{j,i} \leq y_i^* < k_{j+1,i}) \\ &= \Phi[(k_{j+1,i} - \pi_i'x) - (k_{j,i} - \pi_i'x)] \end{aligned} \quad (15)$$

where $\pi_i'x = E(y_i^* \mid x)$ are the conditional expectations of the latent y_i^* variable on the exogenous x variables, and Φ denotes the standard cumulative normal distribution function (Maddala, 1983).

Transformation (14) is the tobit transformation (Tobin, 1958) used to eliminate bias in regressions with censored dependent variables (Amemiya, 1973; Maddala, 1983). An estimation approach to establishing the threshold values internally in the estimation of the entire structural equation model is outlined in Section 6.

The y_i^* variables can thus replace the y indicator variables in latent structural equations whenever the y variables are noncontinuous (dichotomous or ordered polytomous) or censored continuous. The measure of association between two noncontinuous y variables is the correlation between the two latent y^* variables underlying the noncontinuous indicators. This correlation is called a "polychoric" correlation coefficient. In the special case of two transformed dichotomous variables, the polychoric correlation is referred to as a "tetrachoric" correlation; and in the case of a pair involving a continuous variable and a transformed polychotomous variable, it is referred to as a "polyserial" correlation. These correlations are important concepts in model estimation.

As an application of structural equations with non-normal endogenous variables, consider system (10a)-(10b) and Figure 4 with the following transformations between the four pairs of observed and latent

variables: There is an ordered probit model relating the latent level of income variable to observed income in four categories, another ordered probit model relating the latent car ownership variable to three observed categories of the number of cars owned (0, 1, and 2+), and two tobit transformations between the latent mobility variables and trip rates by car and public transport. An alternative treatment of the car ownership latent variable is to break the observed indicator into two dichotomous observed variables--zero versus one car, and one versus two or more cars--and relate each observed dichotomous variable to a corresponding latent car ownership variable. The resulting two binomial probit models, with an error covariance link between the two latent variables is equivalent to a multinomial probit model (Muthén, 1982). Each of these ways of incorporating non-normal variables in a latent structural equation model is used in the application documented in the present paper.

2.4 Longitudinal Models

Latent structural equation models can be particularly effective in analyzing the dynamics of travel behavior. Applied to panel data, such models can incorporate changes over time ("growth curves") of several variables simultaneously, while also including lagged causal relationships between variables. In addition, autocorrelated error structures can be introduced to account for specific types of biases in panel data (Jöreskog and Sörbom, 1977; Jöreskog, 1979).

The ability to postulate responses with time lags is important in many applications, because this allows tests of alternative causality to be conducted: Does y_t cause y_{t+1} , or does y_{t+1} cause y_t ? For an appropriate time interval between panel waves at t and $t + 1$, this implies testing alternative B matrix elements: (1) from $y_{i,t}$ to $y_{i,t+1}$, versus (2) from $y_{i,t+1}$ to $y_{i,t}$. This application of structural equations model represents a generalization of the technique of cross-lagged panel correlation (Kenny, 1973; 1975; Kenny and Horackiewicz, 1979; Rogosa, 1980) and examples are described in Bentler (1984).

The general application to panel data can be visualized by partitioning the vector of endogenous latent variables into T sets of q variables, where the panel data involves the repeated measurement of the q variables over T waves. The corresponding partitioning of the B coefficient matrix in system (8a)-(8b), introduced by Golob and Meurs (1988), is

$$\mathbf{B} = \begin{bmatrix} \mathbf{B}_{11} & \mathbf{B}_{12} & \dots & \mathbf{B}_{1T} \\ \mathbf{B}_{21} & \mathbf{B}_{22} & & \\ \vdots & & \ddots & \\ \mathbf{B}_{T1} & & & \mathbf{B}_{TT} \end{bmatrix} \quad (16)$$

where each $\mathbf{B}_{i,j}$ is a $(q \times q)$ matrix.

Without loss of generality, with three panel waves:

$$\mathbf{B} = \begin{bmatrix} \mathbf{B}_{11} & \mathbf{B}_{12} & \mathbf{B}_{13} \\ \mathbf{B}_{21} & \mathbf{B}_{22} & \mathbf{B}_{23} \\ \mathbf{B}_{31} & \mathbf{B}_{32} & \mathbf{B}_{33} \end{bmatrix} \quad (17)$$

This partitioning of matrix (17) can be depicted in the manner of Figure 5. The \mathbf{B}_{11} , \mathbf{B}_{22} , and \mathbf{B}_{33} matrices in the block diagonal of Figure 5 capture the contemporaneous (cross-sectional) relationships among the endogenous variables; each of these three matrices is defined to have zero elements in the diagonal. The

	<u>Time t_1 Variables</u>	<u>Time t_2 Variables</u>	<u>Time t_3 Variables</u>
<u>Time t_1 Variables</u>	\mathbf{B}_{11} Contemporaneous Effects Time t_1	\mathbf{B}_{12} Anticipatory Effects t_2 to t_1	\mathbf{B}_{13} Anticipatory Effects t_3 to t_1
<u>Time t_2 Variables</u>	\mathbf{B}_{21} Lagged Effects t_1 to t_2	\mathbf{B}_{22} Contemporaneous Effects Time t_2	\mathbf{B}_{23} Anticipatory Effects t_3 to t_2
<u>Time t_3 Variables</u>	\mathbf{B}_{31} Lagged Effects t_1 to t_3	\mathbf{B}_{32} Lagged Effects t_2 to t_3	\mathbf{B}_{33} Contemporaneous Effects Time t_3

FIGURE 5

PARTITIONING THE B STRUCTURAL EQUATIONS PARAMETER MATRIX FOR
THREE-WAVE PANEL DATA

\mathbf{B}_{21} and \mathbf{B}_{32} matrices capture the lagged relationships for a single time period; the diagonal elements of \mathbf{B}_{21} and \mathbf{B}_{32} represent the history-dependence (or inertia) of each variable. And the \mathbf{B}_{31} matrix captures two-period lagged effects. The diagonal elements of \mathbf{B}_{21} , \mathbf{B}_{32} , and \mathbf{B}_{31} for each variable $i = 1, 2, \dots, q$ together comprise the temporal trend (growth curve) for that variable. Nonlinear trends generally require significant multiperiod effects (nonzero diagonal elements in \mathbf{B}_{31}), while linear trends can generally be described with only single-period (first-order) autocorrelations. For a panel with large T , these structural equation parameters can reproduce auto-regressive moving average (ARMA) models (Maravall and Aigner, 1977). The \mathbf{B}_{12} , \mathbf{B}_{23} , and \mathbf{B}_{13} matrices capture effects that are backward in time. In general these will be null matrices, but in some situations there can be effects of "anticipated" variables.

As an example of dynamic structural parameters, a single-lag structure between two waves of the four travel behavior variables in the contemporaneous model of Figure 2 is

$$\mathbf{B}_{21} = \begin{bmatrix} \beta_{11} & 0 & 0 & 0 \\ \beta_{21} & \beta_{22} & \beta_{23} & \beta_{24} \\ \beta_{31} & 0 & \beta_{33} & \beta_{34} \\ 0 & 0 & 0 & \beta_{44} \end{bmatrix} \quad (18)$$

which corresponds to the flow diagram of Figure 6. Here it is postulated that income level at time 2 is a dynamic function only of income level at time 1. Car ownership in time 2, however, is a function of all previous variables: The lagged effect of income on car ownership is consistent with economic theory, and the lagged effects of car and public transport mobility on car ownership represent pressures to increase car ownership in response to high levels of travel demand. Similarly, car mobility is postulated to be lagged function of income and previous public transport mobility. This model can be tested using panel data, provided of course that the system of simultaneous equations is identified.

Dynamic structural equation models also provide a unique opportunity to isolate and correct certain errors that plague predictive behavioral models. This is accomplished by taking advantage of the repeated measurements aspect of panel data. For instance, consistent estimates can be generated even in the presence of model misspecification by either introducing individual regression constants for each individual in the panel sample or adding additional disturbance terms expanding the error variance (an error component model) (Tuma and Hannan, 1984, pp. 438-446; Arminger, 1986; Maddala, 1987). However, Arminger (1987) has demonstrated that some of these corrections for misspecification are not possible when

there are lagged causal effects among the variables. These extensions are beyond the scope of the present paper.

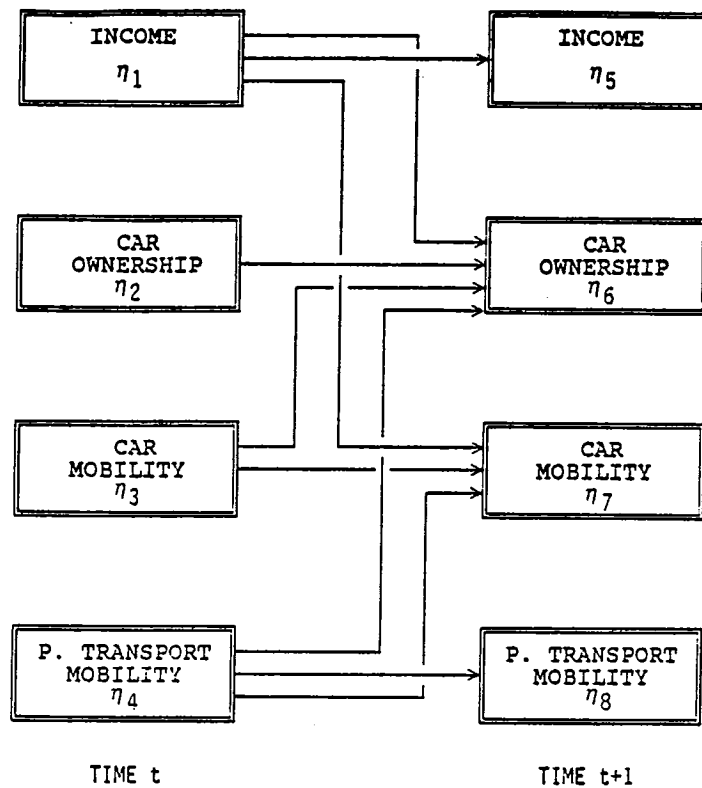

FIGURE 6

FLOW DIAGRAM OF A DYNAMIC STRUCTURAL EQUATION MODEL INVOLVING EIGHT ENDOGENOUS LATENT VARIABLES REPRESENTING FOUR VARIABLES MEASURED AT TWO POINTS IN TIME

2.5 Estimation Methods

Latent structural equation models can be estimated using either maximum likelihood or least squares methods. The former method has traditionally been based on theories appropriate for continuous variables with multivariate normal distributions. Normal theory maximum likelihood estimation was the first estimation method for latent structural equations to be readily available (Jöreskog, 1969; Gruvaeus and Jöreskog, 1970). It is the basis for the widely used LISREL program developed by Jöreskog (1973) (Jöreskog and Sörbom,

1984; 1987). Extensive LISREL applications are documented in Hayduk (1987, pp. xii-xiv), Bentler (1980, 1986), and Blalby and Hauser (1977); applications in the field of travel behavior analysis are provided by den Boon (1980), Golob and Zondag (1983), Golob and Meurs (1987; 1988), and Golob (1989).

Systems with non-normal endogenous variables can be estimated using maximum likelihood methods, if separate pre-estimations of polychoric correlations are conducted. However, it is preferable to employ a generalized least squares approach with non-normal variables because such least squares estimates have been shown to be asymptotically distribution-free. Generalized least square estimators that explicitly accommodate non-normal variables are a relatively recent phenomena (Browne, 1982; 1984; Bentler, 1983a; 1983b; Muthén, 1983; 1984). These recent breakthroughs are based on previous work on elliptical and arbitrary distribution theory by Browne (1974), and Lee and Bentler (1980), among others, and the work on polychoric correlations by Olsson (1979) and Muthén (1978; 1979), among others.

Two generalized least squares computer programs are available: EQS, developed by Bentler (1985), and LISCOMP, developed by Muthén (1987). The LISCOMP program is used in the present application. The remainder of this section outlines the estimation procedure in LISCOMP; the procedures is documented in detail in Muthén (1983; 1984).

The estimation involves a three-stage limited-information generalized least squares (GLS) procedure. In the first stage, the first order statistics for all endogenous variables are consistently estimated using maximum likelihood. For ordered polytomous (including dichotomous) variables, this establishes thresholds that are cut points on the normal distributions. With exogenous variables present, the normal distributions are conditional; for a noncontinuous variable the conditional estimation amounts to a univariate probit regression of the variable on all x variables.

In the second stage, second order statistics are consistently estimated by conditional maximum likelihood given the first order statistics. For p endogenous variables, $p(p-1)/2$ tetrachoric correlation coefficients need to be estimated at this stage. With exogenous variables present, the estimates represent reduced-form residual correlations.

In the third and final stage, the second order statistics are invoked as the weight matrix in a weighted least squares estimation of the parameters of the structural equation and measurement submodels. The objective function of the least squares solution of equation (7) is thus generalized to

$$F = (\mathbf{S} - \Sigma)' \mathbf{W}^{-1} (\mathbf{S} - \Sigma) \quad (19)$$

where \mathbf{W} is the positive-definite weight matrix of second-order statistics estimated in stage two of the procedure. The Σ matrix captures the model parameters (equation (12)), as well as scaling factors (see Muthén, 1983; 1984; for a more detailed treatment). The objective function is minimized using a modified Fletcher-Powell algorithm.

The resulting estimates, as well as those generated by the alternative EQS approach of Bentler (1985), are consistent for any distribution on an asymptotic basis. Thus, relatively large sample sizes should be used with these estimation approaches, and Bentler (1985) recommends a ratio of sample size to the number of free parameters to be estimated of 10:1 or greater. Also, the approaches are computationally expensive in terms of computing time and memory storage. For example, the second stage in the LISCOMP procedure requires the assessment of probabilities for the entire sample at each iteration, where there is an integration of the cumulative normal distribution function of an order equal to the number of noncontinuous endogenous variables. This places a practical limit on the complexity of the model in a microcomputing environment.

3. APPLICATION: INCOME, CARS, AND MOBILITY

3.1 Data description

The application of dynamic latent structural equations with non-normal variables involves four observed travel behavior variables measured at three points in time. The data source is the Dutch National Mobility Panel (J. Golob, et al., 1986; Meurs and van Wissen, 1987). The three points in time are the spring of each of the years 1984, 1985, and 1986, corresponding to waves one, three and five of the Panel. Trip rate data have been weighted to account for bias due to panel attrition and respondent fatigue, according to the weighting scheme described in Meurs and van Wissen (1987).

The four variables are income, car ownership, trips by car, and trips by public transport, all at the household level. Income is measured in terms of four categories, and car ownership is in terms of three

categories (0, 1, and 2 or more cars, there being an insignificant number of households with more than two cars in the sample). The two trip rate variables were extracted from seven-day travel diaries completed by all household members ("diary keepers") over eleven years of age. The variables are in terms of trips per week per diary keeper to account for differences in household size. The variables are described in Table 1.

The analyses employ a sample of 620 households, representing those panel households that did not change the number of diary keepers (members over eleven years of age) over the course of the three waves (1984 through 1986). This sample size implies that the number of free parameters in the models estimated using the asymptotically distribution-free generalized least squares method should be kept below 62 to adhere to the rule-of-thumb of ten observations per parameter.

3.2 Model specification

The application involves the twelve variables listed in Table 1, representing four measurements repeated at three points in time. Each of these non-normal variables, denoted by y_i ($i = 1, \dots, 12$), is postulated to be the observed consequences of a latent variable y_i^* ($i = 1, \dots, 12$). These latent variables are distributed multivariate normally. For the ordinal variables y_1 , y_5 , and y_9 (income measured at the three points in time), the relationship between y_i and y_i^* is

$$y_i = \begin{cases} 3 & \text{if } k_{i,3} < y_i^* \\ 2 & \text{if } k_{i,2} < y_i^* \leq k_{i,3} \\ 1 & \text{if } k_{i,1} < y_i^* \leq k_{i,2} \\ 0 & \text{if } y_i^* \leq k_{i,1} \end{cases} \quad (20)$$

for $i = 1, 5, 9$. For the ordinal variables y_2 , y_6 , and y_{10} (car ownership measured at three points in time), the relationship is

TABLE 1
VARIABLE DESCRIPTIONS

<u>Variable</u>	<u>Measurement</u>	<u>Time Period</u>	<u>Variable Type</u>	<u>Treatment</u>
y_1	household income	1984	4-category ordinal	ordered probit
y_2	household car ownership	1984	3-category ordinal	ordered probit
y_3	car trips per week per diary keeper	1984	zero and positive continuous	censored normal
y_4	public transport trips per week per diary keeper	1984	zero and positive continuous	censored normal
y_5	household income	1985	4-category ordinal	ordered probit
y_6	household car ownership	1985	3-category ordinal	ordered probit
y_7	car trips per week per diary keeper	1985	zero and positive continuous	censored normal
y_8	public transport trips per week per diary keeper	1985	zero and positive continuous	censored normal
y_9	household income	1986	4-category ordinal	ordered probit
y_{10}	household car ownership	1986	3-category ordinal	ordered probit
y_{11}	car trips per week per diary keeper	1986	zero and positive continuous	censored normal
y_{12}	public transport trips per week per diary keeper	1986	zero and positive continuous	censored normal

$$y_i = \begin{cases} 2 & \text{if } k_{i,2} < y_i^* \\ 1 & \text{if } k_{i,1} < y_i^* \leq k_{i,2} \\ 0 & \text{if } y_i^* \leq k_{i,1} \end{cases} \quad (21)$$

for $i = 2, 6, 10$. Finally, for the trip rate variables $y_3, y_4, y_7, y_8, y_{11}$, and y_{12} , which are censored at zero, the corresponding relationship is

$$y_i = \begin{cases} y_i^* & \text{if } y_i^* > k_i \\ 0 & \text{otherwise} \end{cases} \quad (22)$$

for $i = 3, 4, 7, 8, 11, 12$.

The measurement model for the application (equation system (8a)) postulates an identity relationship between the η latent constructs and the y^* variables. Also, there are no exogenous x variables. The structural equations part of the model (equation system (8b)) is thus simplified to

$$y^* = \mathbf{B}y^* + \zeta \quad (23)$$

where y^* and ζ are 12-element vectors and \mathbf{B} is the (12x12) parameter matrix.

The ζ residual terms in (23) can be standardized to unit variance without loss of generality because there are no unconstrained continuous observed variables, and the disturbance term covariances are postulated to be zero because all relationships among the variables are postulated to be captured in the \mathbf{B} matrix structure. This implies

$$\psi = \zeta'\zeta = \mathbf{I} \quad (24)$$

where \mathbf{I} denotes the identity matrix.

The parameters to be estimated in the model defined by equations (20) through (24) are the unknown thresholds in equations (20) (21) and (22) and the elements specified to be nonzero in the (12x12) \mathbf{B} matrix of the structural equation system (23). The thresholds in equations (20) and (21) are estimated using ordered-response probit models (equation (15)); and the thresholds in equation (22) are estimated using the tobit transformations, both as described in Section 2.3. The structural equation (\mathbf{B}) parameters are estimated conditional upon the thresholds using the generalized least squares approach described in Section 2.5.

The \mathbf{B} parameter matrix partition of equation (17) and Figure 5 is used, with \mathbf{B} (12 x 12) and each \mathbf{B}_{ij} (4 x 4). The contemporaneous relationships among the variables at each point in time, $\mathbf{B}_{11} = \mathbf{B}_{22} = \mathbf{B}_{33}$, is

given by system (10b). These contemporaneous relationships are depicted together with the measurement of model (10a) in Figure 4.

The dynamic relationships representing lagged effects for one time period, $B_{21} = B_{32}$, is given by definition (18) and depicted in the flow diagram of Figure 6. The B_{31} , two-period effect submatrix is specified to be diagonal in order to account for nonlinear temporal trends. The B_{12} , B_{23} , and B_{13} matrices are null, with the exception of four parameters representing the effects of anticipated income; these are described in the following section.

3.3 Parameter estimation

The model fit the data well with only a few modifications. The final model had 36 free parameters, and the standardized estimates and z-statistic for the free parameters are listed in Table 2. The chi-square statistic for the model, evaluated at the minimum value of the objective function (19), is 38.23 with 30 degrees of freedom. This represents a probability of $p = .144$; the model cannot be rejected at the $p = .05$ level. The root-mean-square-residual statistic (Golob and Meurs, 1988) is 0.027, indicating very good correspondence between the sample variance-covariance matrix and the variance-covariance matrix replicated by the model.

A key subset of model results involve the effects on the four variables at the central time period, $t = 2$ (1985). These are the estimates of the parameters for the fifth through eighth rows of the B (12×12) matrix: β_{ij} ($i = 4, 5, 6, 7; j = 1, 2, \dots, 12$). There were sixteen parameters in this portion of the matrix that were postulated to be nonzero, and these are parameters numbered 8 through 23 in Table 2. All parameters with the exception of the last one (parameter number 23) were significantly different from zero at the $p = .05$ level for one-tailed tests (Table 2).

The sixteen standardized parameters are displayed in the flow diagram of Figure 7, which is a subset of the complete model flow diagram. Focusing on the contemporaneous relationships among the variables in the 1985 (second) time period:

- (1) Car ownership is a contemporaneous (positive) function of income.

- (2) Car mobility is a contemporaneous (positive) function of car ownership, but the effect of income on car mobility is channeled exclusively through car ownership (no direct income-car mobility link).
- (3) Public transport is a (negative) function of both car ownership and car mobility; i.e., both owning and using cars implies less public transport use. However, public transport mobility is a positive function of income; holding car ownership and use constant, a higher level of income implies a higher use of public transport.

The dynamic relationships can be divided into three groups, the first of which are inertial effects for each variable (the diagonal elements in the B_{21} submatrix of equation (16)). The strongest inertia is for car ownership, and the weakest is for car mobility. This indicates that, while there is very little turnover in car ownership over the time period, there is considerably more variation in levels of car trip-making from 1984 to 1985.

The second group of dynamic relationships are the cross-lagged effects from 1984 to 1985 (off-diagonal elements in the B_{21} submatrix):

- (1) Income has a lagged effect on both car ownership and car mobility, but not on public transport mobility.
- (2) Car ownership in 1985 is a (positive) function of car mobility in 1984; higher car use implies a need to increase car ownership.
- (3) Car ownership in 1985 is also a (negative) function of public transport mobility in 1984; high public transport use implies a need to reduce car ownership.

Finally, the third group of dynamic relationships involves the effects from future time 1986 to present time 1985 (the elements of the B_{23} submatrix). In general, these effects are illogical (Golob and Meurs, 1988). However, with regard to car ownership and mobility they capture the influences of anticipated future income:

- (1) Households with higher future income levels have higher car ownership levels, all else constant.
- (2) Households with higher future income levels also exhibit higher levels of public transport mobility, all else constant.

These effects of anticipated future income were not originally postulated; rather, they were discovered through investigations of the first derivatives of the objective function (19). Tests of nested models revealed that the effects of anticipated income are significant at the $p < .01$ level. This is an example of the insights into travel behavior that might be gained using latent structural equation models.

TABLE 2

MODEL ESTIMATES

(*indicates coefficient significantly different from zero at $p = .05$ for one-tailed tests)

<u>Parameter Number</u>	<u>Beta Element</u>	<u>Standard-ized Estimate</u>	<u>Z-Statistic</u>	<u>Parameter Number</u>	<u>Beta Element</u>	<u>Standard-ized Estimate</u>	<u>Z-Statistic</u>
1	(2,1)	.433	11.20*	19	(8,4)	.762	18.38*
2	(2,5)	.122	6.44*	20	(8,5)	.083	2.64*
3	(3,2)	.655	27.72*	21	(8,6)	-.155	-4.55*
4	(4,1)	.256	4.59*	22	(8,7)	-.079	-2.02*
5	(4,2)	-.321	-6.68*	23	(8,9)	.041	1.45
6	(4,3)	-.276	-6.81*	24	(9,1)	.676	28.91*
7	(4,5)	.043	1.80*	25	(9,5)	.178	12.09*
8	(5,1)	.847	75.95*	26	(10,2)	-.314	-4.49*
9	(6,1)	.312	4.85*	27	(10,3)	.133	3.01*
10	(6,2)	1.125	12.96*	28	(10,6)	1.034	23.25*
11	(6,3)	.203	4.34*	29	(10,9)	.041	1.83*
12	(6,4)	-.176	-3.68*	30	(11,3)	.407	11.94*
13	(6,5)	.090	4.14*	31	(11,5)	.040	2.56*
14	(6,9)	.050	1.93*	32	(11,7)	.496	17.17*
15	(7,1)	-.110	-2.91*	33	(11,210)	.147	7.50*
16	(7,3)	.541	18.39*	34	(12,4)	.407	8.35*
17	(7,4)	.055	2.15*	35	(12,8)	.445	10.66*
18	(7,6)	.205	9.20*	36	(12,10)	-.044	-1.88*

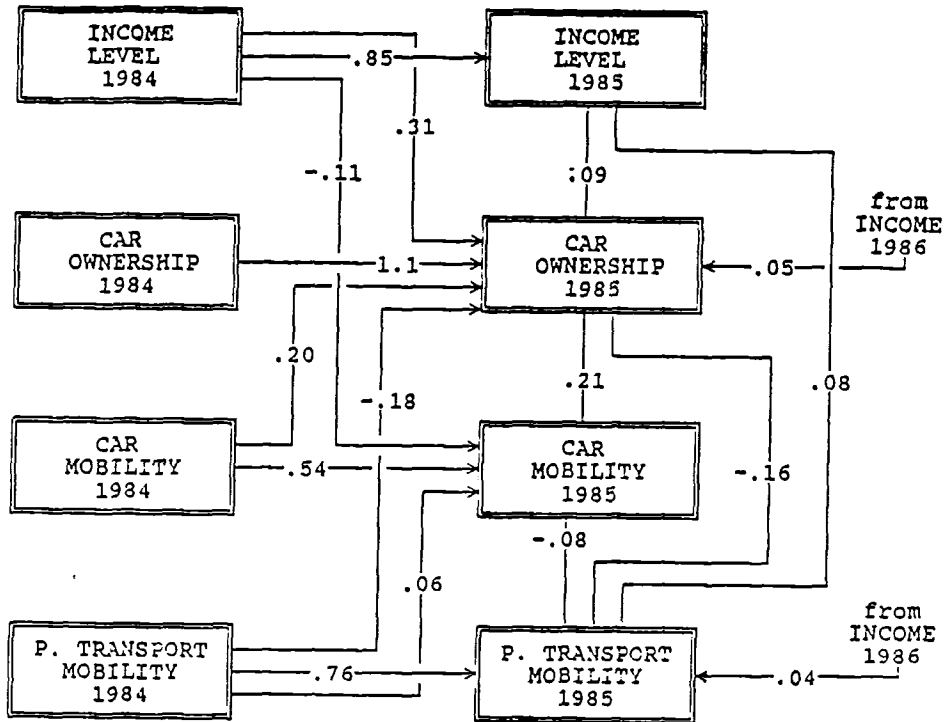

FIGURE 7
 FLOWS TO THE VARIABLES AT THE SECOND POINT IN TIME, WITH
 STANDARDIZED COEFFICIENT VALUES, FOR THE ESTIMATED MODEL

3.4 Total causal effects

Each of the elements β_{ij} of the **B** parameter matrix estimated in Table 1 and partially depicted in the flow diagram of Figure 7 represent the direct causal effects of variable y_j^* on variable y_i^* , as postulated by the structural equations model. However, the total causal effect of any variable on any other variable is the sum total of the direct effect, if it exists, and all of the indirect effects represented by paths through intermediate variables. That is, variable y_j can influence variable y_i even if there is no direct effect from y_j to y_i ($\beta_{ij} = 0$) provided that variable y_j affects at least one other variable, y_k , that affects y_i ($\beta_{ik} \neq 0$).

Total effects are calculated from the structural equation system (23) as the coefficients of the reduced-form regression equations. Denoting the (12x12) matrix of direct effects in the present application as **A**, with elements α_{ij} :

$$\mathbf{A} = (\mathbf{I} - \mathbf{B})^{-1} \cdot \mathbf{I}$$

where, as before, **I** denotes the identity matrix and **B** is the matrix of structural equation coefficients.

The total effects calculated from the model results of Table 2 are listed in Table 3. Some of the key results are:

- (1) There are relatively strong total effects from income in the base year to car mobility in the base year and in subsequent years, even though there are no positive direct effects; the effects are indirect, mostly through car ownership.
- (2) The contemporaneous total effects of income on public transport mobility in each year are positive, but these total effects are relatively small and less than the contemporaneous direct effects; all lagged total effects of income on public transport mobility are negative and relatively small.
- (3) There are relatively strong negative total effects on public transport mobility in all time periods from both car ownership and car mobility in the base year, with the car ownership effects being consistently stronger than the car mobility effects.
- (4) Public transport mobility in the base year has negative total effects on car ownership in subsequent years, indicating the public transport use is somewhat effective in suppressing car ownership.

TABLE 3
TOTAL EFFECTS BETWEEN VARIABLES (ONLY NONZERO VALUES SHOWN)

	y_1	y_2	y_3	y_4	y_5	y_6	y_7	y_8	y_9	y_{10}	y_{11}	y_{12}
y_1	-	-	-	-	-	-	-	-	-	-	-	-
y_2	0.54	-	-	-	0.12	-	-	-	-	-	-	-
y_3	0.35	0.66	-	-	0.08	-	-	-	-	-	-	-
y_4	0.02	-0.50	-0.28	-	-0.02	-	-	-	-	-	-	-
y_5	0.85	-	-	-	-	-	-	-	-	-	-	-
y_6	1.10	1.35	0.25	-0.18	0.26	-	-	-	0.05	-	-	-
y_7	0.31	0.60	0.58	0.02	0.10	0.21	-	-	0.01	-	-	-
y_8	-0.07	-0.64	-0.30	0.79	0.03	-0.17	-0.08	-	0.03	-	-	-
y_9	0.83	-	-	-	0.18	-	-	-	-	-	-	-
y_{10}	1.05	1.17	0.39	-0.18	0.24	1.03	-	-	0.09	-	-	-
y_{11}	0.48	0.74	0.75	-0.02	0.16	0.25	0.50	-	0.02	0.15	-	-
y_{12}	-0.07	-0.54	-0.26	0.77	-0.01	-0.12	-0.04	0.45	0.01	-0.04	-	-

8. Acknowledgments

The author would like to thank Bureau Goudappel Coffeng of Deventer, The Netherlands, for providing the data, technical assistance, and consulting environment necessary to support this research. In particular, thanks are due to Henk Meurs, Co Holzapfel, and Jacqueline Visser of Bureau Goudappel Coffeng, and Leo van Wissen of the Amsterdam Free University for their help and advice. The research represents an extension of the Dutch National Mobility Panel projects supported by the Project Bureau for Integrated Transport and Traffic Studies and the Office of the Director General of Transport of the Ministry of Transport and Public Works of the Netherlands. Cynthia Wenks and Jean Galbraith of ITS-Irvine expertly prepared the manuscript. The author is solely responsible for all views expressed and any remaining errors.

REFERENCES

- Aitchison, J., and S. Silvey (1957). The generalization of probit analysis to the case of multiple responses. *Biometrika*, 44: 131-140.
- Amemiya, T. (1973). Regression analysis when the dependent variable is truncated normal. *Econometrica*, 41: 997-1016.
- Arminger, Gerhard (1986). Linear stochastic differential equation models for panel data with unobserved variables. In Nancy Brandon Tuma (ed.), *Sociological Methodology 1986*: 187-212. San Francisco: Jossey-Bass.
- Arminger, Gerhard (1987). Misspecification, asymptotic stability, and ordinal variables in the analysis of panel data. *Sociological Methods and Research*, 15: 336-348.
- Ashford, J.R. (1959). An approach to the analysis of data for semi-quantal responses in biological response. *Biometrics*, 15: 573-581.
- Bentler, P.M. (1980). Multivariate analysis with latent variables: Causal modeling. *Annual Review of Psychology*, 31: 419-456.
- Bentler, P.M. (1983a). Some contributions to efficient statistics in structural models: Specification and estimation of moment structures. *Psychometrika*, 48: 493-517.
- Bentler, P.M. (1983b). Simultaneous equation systems as moment structure models. *Journal of Econometrics*, 22: 13-42.
- Bentler, P.M. (1984). Structural equation models in longitudinal research. In S.A. Mednick, M. Harway, and K.M. Finello (eds), *Handbook of Longitudinal Research*, Vol. 1: 88-105. New York: Praeger.
- Bentler, P.M. (1985). Theory and implementation of EQS, a structural equations program, Version 2. Los Angeles: BMDP Statistical Software.
- Bentler, P.M. (1986). Structural modeling and Psychometrika: An historical perspective on growth and achievements. *Psychometrika*, 51: 35-51.
- Bentler, P.M., and David G. Weeks (1985). Some comments on structural equation models. *British Journal of Mathematical and Statistical Psychology*, 38: 120-121.
- Bielby, W.T., and R.M. Hauser (1977). Structural equation models. *Annual Review of Sociology*, 3: 137-161.
- Blalock, H.M., Jr. (1979). Measurement and conceptualization problems: The major obstacle to integrating theory and research. *American Sociological Review*, 44: 881-894.
- Blalock, H.M., Jr. (1982). *Conceptualization and Measurement in the Social Sciences*. Beverly Hills: Sage.
- Bohrnstedt, G.W. (1983). Measurement. In Peter Rossi, James Wright, and Andy Anderson (eds), *Handbook of Survey Research*: 69-121. New York: Academic Press.

- Browne, M.W. (1974). Generalized least squares estimators in the analysis of covariance structures. *South African Statistical Journal*, 8: 1-24. (Reprinted in D.J. Aigner and A.S. Goldberger, eds, (1977). *Latent Variables in Socio-Economic Models*. Amsterdam: North-Holland.)
- Browne, M.W. (1982). Covariance structures. In Douglas M. Hawkins (ed.), *Topics in Applied Multivariate Analysis*: 72-141. Cambridge: Cambridge University Press.
- Browne, M.W. (1984). Asymptotically distribution-free methods for the analysis of covariance structures. *British Journal of Mathematical and Statistical Psychology*, 37: 62-83.
- den Boon, A.K. (1980). *Opvattingen over autogenbruik en milieuvuiling*. Baschwitz Instituut, Universiteit van Amsterdam, Nederland.
- Golob, J.M., L.J.M. Schreurs, and J.G. Smit (1986). The design and policy applications of a panel for studying changes in mobility over time. In *Behavioural Research for Transport Policy*: 81-95. Utrecht, The Netherlands: VNU Press.
- Golob, T.F. (1989). The causal influences of income and car ownership on trip generation by mode. *Journal of Transport Economics and Policy* (forthcoming).
- Golob, T.F., and H. Meurs (1987). A structural model of temporal change in multi-modal travel demand. *Transportation Research*, 21A: 391-400.
- Golob, T.F., and H. Meurs (1988). Development of structural equations models of the dynamics of passenger travel demand. *Environment and Planning A*, 20: 1197-1218.
- Golob, T.F., and E.R. Zondag (1983). A causal model of mobility. Presented at the Tenth Transportation Planning Research Colloquium, Zandvoort, The Netherlands, 14-16 December 1983.
- Fornell, C., and D.F. Larcker (1981). Structural equation models with unobservable variables and measurement error: Algebra and statistics. *Journal of Marketing Research*: 382-388.
- Gruvaeus, G.T., and K.G. Jöreskog (1970). A computer program for minimizing a function of several variables. Research Bulletin 70-14. Princeton, NJ: Educational Testing Service.
- Hayduk, L.A. (1987). *Structural Equation Modeling with LISREL*. Baltimore: Johns Hopkins University Press.
- Jöreskog, K.G. (1969). A general approach to confirmatory maximum likelihood factor analysis. *Psychometrika*, 34: 183-202.
- Jöreskog, K.G. (1973). A general method for estimating a linear structural equation system. In A.S. Goldberger and O.D. Duncan (eds), *Structural Equation Models in the Social Sciences*: 85-112. New York: Seminar Press.
- Jöreskog, K.G. (1979). Statistical estimation of structural models in longitudinal-developmental investigations. In J. Nesselroade and P. Baltes (eds), *Longitudinal Research in the Study of Behavior and Development*: 303-351. New York: Academic Press.
- Jöreskog, K., and D. Sörbom (1977). Statistical models and methods for analysis of longitudinal data. In D. Aigner and A.S. Goldberger (eds), *Latent Variables in Socioeconomic Models*: 285-325. Amsterdam: North-Holland.
- Jöreskog, K., and D. Sörbom (1984). *LISREL VI: Analysis of Linear Structural Relationships by Maximum Likelihood, Instrumental Variables, and Least Squares Methods*. Mooresville, Ind.: Scientific Software, Inc.

- Jöreskog, K., and D. Sörbom (1987). New developments in LISREL. *Data Analyst*, 4: 1-22.
- Jöreskog, K., and H. Wold (eds) (1982). *Systems under Indirect Observation: Causality, Structure, Prediction*, Part I. New York: North-Holland.
- Kenny, D.A. (1973). Cross-lagged and synchronous common factors in panel data. In A.S. Goldberger and O.D. Duncan (eds), *Structural Equation Models in the Social Sciences*: 887-903. New York: Seminar Press.
- Kenny, D.A. (1975). Cross-lagged panel correlation: A test for spuriousness. *Psychological Bulletin*, 82: 887-903.
- Kenny, D.A., and J.M. Horackiewicz (1979). Cross-lagged panel correlation: Practice and promise. *Journal of Applied Psychology*, 64: 372-379.
- Lee, S.Y., and P.M. Bentler (1980). Some asymptotic properties of constrained least squares estimation in covariance structure models. *South African Statistical Journal*, 14: 121-136.
- Maddala, G.S. (1983). *Limited-Dependent and Qualitative Variables in Econometrics*. Cambridge: Cambridge University Press.
- Maddala, G.S. (1987). Recent developments in the econometrics of panel data analysis. *Transportation Research*, 21A: 303-326.
- Maravall, A. and D.J. Aigner (1977). Identification of the dynamic shock-error model: The case of dynamic regression. In D.J. Aigner and A.S. Goldberger (eds), *Latent Variables in Socio-Economic Models*: 349-383. Amsterdam: North-Holland.
- Meurs, H., and L. van Wissen (1987). Analysis of panel data. Presented at Round Table Conference on the Analysis of Panel Data, The Hague, May 14-15, 1987.
- Muthén, B. (1978). Contributions to factor analysis of dichotomous variables. *Psychometrika*, 43: 551-560.
- Muthén, B. (1979). A structural probit model with latent variables. *Journal of the American Statistical Association*, 74: 807-811.
- Muthén, B. (1982). Some categorical response models with continuous latent variables. In K.G. Jöreskog and H. Wold (eds), *Systems under Indirect Observation: Causality, Structure, Prediction*. Amsterdam: North-Holland.
- Muthén, B. (1983). Latent variable structural equation modeling with categorical data. *Journal of Econometrics*, 22: 43-65.
- Muthén, B. (1984). A general structural equation model with dichotomous, ordered categorical, and continuous latent variable indicators. *Psychometrika*, 49: 115-132.
- Muthén, B. (1987). Some uses of structural equation modeling in validity studies: Extending IRT to external variables. In H. Wainer and H. Braun (eds), *Test Validity*. Hillsdale, NJ: Erlbaum Associates (in press).
- Olsson, U. (1979). Maximum likelihood estimation of the polychoric correlation coefficient. *Psychometrika*, 44: 443-460.
- Rogosa, D. (1980). A critique of cross-lagged correlation. *Psychological Bulletin*, 88: 245-258.

- Tobin, J. (1958). Estimation of relationships for limited dependent variables. *Econometrica*, 26: 24-36.
- Tuma, N.B., and M.T. Hannan (1984). *Social Dynamics: Models and Methods*. Orlando, FL: Academic Press.
- Wold, H. (1982). Soft modeling: The basic design and some extensions. In K.G. Jöreskog and H. Wold (eds.), *Systems under Indirect Observation: Causality, Structure, Prediction*; Vol. II: 1-54. Amsterdam: North-Holland.