

Lawrence Berkeley National Laboratory

Recent Work

Title

SIMPLIFIED HELIUM CRYOSTATS FOR SUPERCONDUCTING DIPOLES AND QUADRUPOLE MAGNETS

Permalink

<https://escholarship.org/uc/item/3f5975cc>

Author

Green, Michael A.

Publication Date

1970-07-01

RECEIVED
LAWRENCE
RADIATION LABORATORY

UCRL-19764
UC-38 Eng. and Equip.
TID-4500 (56th Ed.)

NOV 13 1970

c. 2

LIBRARY AND
DOCUMENTS SECTION

SIMPLIFIED HELIUM CRYOSTATS FOR
SUPERCONDUCTING DIPOLES AND QUADRUPOLE
MAGNETS

Michael A. Green

July 29, 1970

AEC Contract No. W-7405-eng-48

TWO-WEEK LOAN COPY

*This is a Library Circulating Copy
which may be borrowed for two weeks.
For a personal retention copy, call
Tech. Info. Division, Ext. 5545*

LAWRENCE RADIATION LABORATORY
UNIVERSITY of CALIFORNIA BERKELEY

UCRL-19764

c. 2

DISCLAIMER

This document was prepared as an account of work sponsored by the United States Government. While this document is believed to contain correct information, neither the United States Government nor any agency thereof, nor the Regents of the University of California, nor any of their employees, makes any warranty, express or implied, or assumes any legal responsibility for the accuracy, completeness, or usefulness of any information, apparatus, product, or process disclosed, or represents that its use would not infringe privately owned rights. Reference herein to any specific commercial product, process, or service by its trade name, trademark, manufacturer, or otherwise, does not necessarily constitute or imply its endorsement, recommendation, or favoring by the United States Government or any agency thereof, or the Regents of the University of California. The views and opinions of authors expressed herein do not necessarily state or reflect those of the United States Government or any agency thereof or the Regents of the University of California.

SIMPLIFIED HELIUM CRYOSTATS FOR SUPERCONDUCTING DIPOLES AND QUADRUPOLE MAGNETS

Michael A. Green

Lawrence Radiation Laboratory
University of California
Berkeley, California 94720

July 29, 1970

ABSTRACT

The most expensive part of a superconducting magnet installation is often the magnet cryostat. Extensive use of superconducting dipole and quadrupole magnets requires study of the cryostat problem from a systems viewpoint.

This paper presents a number of suggestions that should lead to magnet cryostats of minimum cost. The interaction of the cryostat with the refrigeration system is discussed. Basic cryostat design parameters are treated and design conditions for three types of superconducting dipole and quadrupole cryostats are presented.

INTRODUCTION

The most ignored and often the most expensive part of a superconducting magnet installation is the magnet cryostat. Only a few papers have been written that describe the cryostat problem.¹⁻³ The user of superconducting dipoles and quadrupoles for accelerator experimental areas or synchrotrons requires that the cryostat problem be investigated from a systems viewpoint. The basic problem is to assure that a cryostat be made to perform all the functions required of it and still be made as economically as possible. It is quite obvious that there are no pat answers to this problem, but it is also obvious that present laboratory techniques are both inadequate and expensive for large-scale use of superconducting dipoles and quadrupoles.

A magnet cryostat performs only two primary functions. The first is to insulate

the cold helium (I avoid the words "liquid helium," because that makes an assumption which in some cases is not valid) from the room-temperature environment. The second is to support the magnet rigidly against a variety of forces that can exist between the room-temperature and cold environments. The forces that must be considered include not only magnet and electrical forces but also gravitational force.

The method used to refrigerate the magnet is intimately involved with a design of a magnet cryostat. Refrigeration of superconduction magnets is therefore treated here (and in other papers). The characteristics of materials used to build and insulate cryostats are discussed.

The cost of a dipole or quadrupole cryostat is influenced by the geometric shape of the cryostat; the number and type of cold and warm joints; the number and size of connections with

the outside world; the type of support system (i. e., tension or compression rods), which is influenced by the magnitude and direction of the forces as well as by the geometric constraints of the system; the inclusion of intermediate-temperature shields and support points; and whether the magnet has a warm or cold bore.

I stated in the first paragraph that there are no pat solutions to the cryostat problem. However, reasonable solutions can be found for a number of the major types of superconducting dipole and quadrupole systems. Recommendations are therefore presented for (a) short, large-bore experimental magnets for low-energy machines such as the LRL Bevatron; (b) long relatively small-aperture experimental magnets for machines such as Brookhaven AGS and the NAL machine; and (c) high-energy superconducting synchrotron magnets.

REFRIGERATION OF SUPERCONDUCTING MAGNETS

The refrigeration of large systems of superconducting magnets has been discussed in a number of papers.⁴⁻⁷ There are four primary methods of providing refrigeration for superconducting magnets. They include (a) an open liquid-helium pot, where the liquid is supplied by a liquefier and warm gas is returned to the liquefier, (b) conventional helium refrigeration,^{1, 7} where a mechanical refrigerator provides the liquid helium and takes back all or most of the cold boiloff gas, (c) supercritical single-phase dense gas refrigeration, where the magnet is cooled by supercritical helium in tubes,⁸ and (d) superfluid refrigeration, where helium II is used at temperatures near 2°K.⁹

It is my opinion that the first and fourth methods will not be used in large-scale superconducting dipoles and quadrupoles. It is quite

possible that superfluid refrigeration will be used on superconducting magnets that are to be in or near a superconducting linear accelerator, or on magnets that need the low temperatures and exceptional heat-transfer properties of helium II. Both the first and the fourth methods of refrigeration suffer from the fact that they cost several times as much per watt in both capital and operating cost (see Table I).⁴⁻⁶ Both methods of refrigeration require complicated (therefore expensive) cryostats in order to bring the heat load down to a tolerably low level.

It is my belief that conventional refrigeration and supercritical (gas cooling) refrigeration will see wide use in future installations involving large numbers of superconducting dipoles and quadrupoles. The capital and operating costs of the two refrigeration systems are nearly the same. It is clear that supercritical refrigeration offers some distinct advantages in reducing cryostat costs for certain kinds of magnet systems. The design of the cryostat is therefore quite dependent on the choice of refrigeration system.

The conventional refrigeration system, whether it involves many small refrigerators or one large refrigerator, must have a magnet cryostat that meets the following requirements: (a) it must have a container or pot, to be filled with liquid helium, that surrounds the superconducting magnet; (b) the pot must have necks to the outside world for electrical leads, for refrigeration, and for venting in the event of magnet quench; (c) in the design of Dewar and magnet special precautions must be taken so that the magnet can be cooled down; (d) a support system must be supplied; (e) the liquid helium region must be insulated from the room-temperature region.

Supercritical refrigeration will greatly simplify cryostat construction. The following components of the conventional Dewar can be

Table I. Capital and operating costs of refrigeration.

Refrigeration source	Incremental capital cost US \$/Watt	Incremental operating cost US \$/Watt hour
Purchased liquid - no gas recovery	-----	2.50 to 4.00
Liquid from small liquefier (9 to 20 liters/h); gas recovered warm	3000 to 5000	0.30 to 0.60
Liquid from large liquefier (60 to 200 liters/h); gas recovered warm	1000 to 2500	0.10 to 0.30

One small refrigerator (40 to 100 W at 4.5°K ^b); small compressors	800 to 1500	0.040 to 0.15 ^c
Many small refrigerators (40 to 100 W at 4.5°K ^b); many units operated on a large compressor system	500 to 900	0.015 to 0.05
One large refrigerator (200 to 1000 W at 4.5°K ^b); single-unit concentrated load	300 to 700	0.015 to 0.07
Several large refrigerators (200 to 1000 W at 4.5°K ^b); run off large central compressor house	225 to 400	0.01 to 0.04
Very large refrigerator (10 000 W and up at 4.5°K ^b) for synchrotron	100 to 175	0.005 to 0.012

Large helium II refrigerator (200 to 500 W at 1.9°K); single unit	700 to 1500	0.04 to 0.20
Very large helium II refrigerator (5000 W up at 1.9°K	300 to 500	0.02 to 0.04

a. Refs. 4 through 6.		
b. Note that ordinary 4.5°K refrigeration and 5°K supercritical refrigeration cost the same. Note also that the capital and operating costs of helium transfer lines are not included here.		
c. Based on LRL operating costs, (Ref. 12).		

eliminated the cryogenic vessel itself, because (a) the cold gas is carried in tubes; (b) a neck for venting, and leads, because a magnet transition produces no large volumes of gaseous helium to be disposed of; (c) special cooldown apparatus, because the cooldown is direct. The support system and insulation system are still required, but in many cases they can be simplified. The only other thing that would be required is an additional Joule-Thomson (J-T) heat exchanger (probably near

the magnet) and a J-T valve in the refrigeration circuit.

Supercritical helium refrigeration is attractive when used in the following ways:

(a) In large superconducting magnets, in which high current densities are not needed and in which hollow superconductor can be used without difficulty.^{8, 10}

(b) In special magnets, such as thin septa and thin beam-slitting magnets where thin conductors and moderate fields are needed.¹¹

Supercritical helium will also become attractive for the general experimental area, and for superconducting synchrotron dipoles and quadrupoles (which require high-current-density windings), if these magnets are made with extremely fine-stranded, intrinsically stable, low-ac-loss materials. The heat generated in these magnets is low enough to be conducted through windings to cooling fins or tubes located at the winding boundary. Experimental work now under way can prove or disprove the validity of the above statement.

A comparison of refrigeration costs is shown in Table I.²⁻⁴ The top of the table shows the costs involved with liquefier capitalization and operation. The bottom of the table shows costs associated with a superfluid helium system (helium below the λ point). It is quite clear these costs are much higher than for the various schemes for conventional refrigeration shown in the middle of the table. Supercritical refrigeration systems are assumed to cost the same if they operate at 5°K instead of 4.5°K. In any event it must be assumed that large systems of superconducting dipoles and quadrupoles will be operated on refrigerator, not on liquid with warm gas return.

When one discusses refrigeration for superconducting magnets one must understand the effect of gas flow through shields and leads. In general the flow of 1 liquid liter per hour of gas (25 SCFH, or 0.708 m³/hr at STP) through leads or shields being returned to the system at room temperature is equivalent to 3 to 4 watts of refrigeration.^{7, 13} This equivalent load must be added to the heat leak entering the Dewar. It is quite clear that most studies of leads are useless for understanding lead performance on a refrigerator. In general, the refrigeration required to operate a magnet lead pair is of the order of 7 to 13 watts per 1000 A (the minimum figure is the

theoretical and has not been achieved at LRL). The refrigeration needed for gas-cooled shields and support points is of the order of 0.25 to 0.4 W per watt intercepted at the shield. These refrigeration requirements must be considered in the design of minimum-cost cryostat for use on a conventional or supercritical refrigerator.

CRYOSTAT DESIGN PARAMETERS

This section describes a number of things that influence the design and cost of cryostats for quadrupoles and dipoles. The design parameters discussed in this section are:

- (a) the cryostat geometry,
- (b) the cryostat insulation system,
- (c) the cryostat support system
- (d) the effect of iron location on design,
- (e) cryostat materials,
- (f) the cryostat bore temperature, and
- (g) the effect of intermediate shields on cost.

Included in the section are tables that describe the parameters of insulations and support system materials.

Geometry

The geometry of the cryostat influences both its function and its cost. Complicated geometric shapes should be avoided if costs are to be minimized. Cryostats (for supercritical helium operation) which have no inner vessel, hence, no necks, can be made considerably cheaper than ones with an inner liquid-containing vessel with its associated necks. A cylindrical-geometry inner vessel with a small number of relatively small necks probably is least expensive. Adequate room should be provided for insulation and long supports. Breakable cold joints and seals should be minimized. Welded joints probably are cheapest if the magnet is not to be removed. Adequate space in the inner can should be provided for leads and the refrigeration J-T valve when

Table II. Heat flow through various insulation systems (Refs. 14, 15).

Insulation system	Heat flow (W)	
	300 to 4°K No intermediate shield	80 to 4°K 80°K intermediate shield
Vacuum $\epsilon = 1$	4.65×10^{-2}	2.30×10^{-4}
Vacuum $\epsilon = 0.5$	1.52×10^{-2}	7.60×10^{-5}
Vacuum $\epsilon = 0.2$	5.06×10^{-3}	2.56×10^{-5}
Vacuum $\epsilon = 0.1$	2.38×10^{-3}	1.21×10^{-5}

Superinsulation, ^a $\epsilon = 0.02$ for each layer		
1 layer	8×10^{-4}	4×10^{-6}
5 layers	3×10^{-4}	1.5×10^{-6}
10 layers	1.5×10^{-4}	
20 layers	7×10^{-5}	less than 10^{-6} unless compacted
50 layers	3×10^{-5}	

Powder insulation evacuated expanded perlite with a density of 0.08 to 0.1 g/cm ³ , layer 15 cm thick	$\approx 1.3 \times 10^{-4}$	$\approx 2 \times 10^{-5}$ (no better than vacuum)

a. The superinsulation values are an order-of-magnitude estimate which can be used for estimating insulation requirements for magnet cryostats.		

conventional refrigeration is to be used. The inner vessel should be capable of withstanding 60 to 100 psig when conventional refrigeration is used; the tubes carrying supercritical helium should have an operating pressure rating of 300 psi.

Insulation

Several insulation systems are commonly used in cryogenic vessels today. The best of these systems is the vacuum superinsulation system^{14, 15} (see Table II). If a gas-cooled or liquid-nitrogen-cooled shield is used, only

a few layers of superinsulation are required between it and the liquid-helium-temperature system. Systems that must withstand moderate amounts of support pressure (a few psi) across the insulation can use nylon netting between layers without greatly increasing the heat leak through the insulation. The cost of nylon netting and double-sided aluminized Mylar is of the order of 0.02 to 0.03 U.S. dollars per ft² (0.20 to 0.30 U.S. \$/m²).¹⁶ Some improvement in insulation efficiency can be gained by using materials that cost an order of magnitude more; in general, the extra cost is not justified.

The cost of applying superinsulation systems is greatly affected by the geometry of the cryostat, the type of supports, and the number of necks. Cryostats cooled with supercritical helium should be somewhat cheaper to superinsulate than those using conventional refrigeration.

Support

Support (from the outside world) of the cold environment may be by either tension or compression members.^{2, 17} A number of materials are suitable for use as support members; these are compared in Table III.^{14, 17} The type of material to be used and its length are functions of the type of loading to be encountered and whether or not intermediate shields are to be used.

Two general types of support systems can be considered for use in dipole or quadrupole cryostats. They are (a) the constant-position system; which can be designed for forces in any direction,² and (b) a support system which supports well in only one direction, for cases in which gravity is the dominant force. The first type of support system may use either tension or compression members.¹⁷ This system must be used where strong magnetic forces can be expected to be encountered; it has the further advantage that no change of the magnet position occurs during cooldown. The second system, which involves supporting the cold vessel (or magnet) from below or hanging it from above, can be used only for systems in which gravity is by far the predominant force. This system's primary advantage is its lower cost. However, one must take into consideration the effects of expansion and contraction on the magnet position.

Iron Location

Iron in some form is used in most dipole and quadrupole systems. The reasons for this are as follows: (a) To increase field for the same number of ampere-turns. (b) To shield adjacent equipment from the field in the magnet (particularly important for pulsed magnet systems). (c) To shield charged-particle beams from other magnets. (d) To help shape the field in some types of magnets.¹⁸ In recent years discussions have centered around both saturated and unsaturated iron systems (in this paper I define saturation as the point at which the relative permeability of iron drops below 75). Saturated iron systems have the advantage of more field per ampere turn; however, their primary disadvantage is a large increase in field aberrations (particularly sextupole and decapole in superconducting dipoles) as the magnet iron begins to saturate. Only by using unsaturated iron can the good field region be kept large over a wide range of magnet excitations.

The iron in a superconducting magnet system may be used at either room temperature or helium temperature. (There appears to be no advantage in using iron at intermediate temperatures.) The advantages for having unsaturated iron at room temperature are obvious:

- (a) There is no large iron mass to be cooled down.
- (b) The area and weight of the cryostat is minimized.
- (c) There is no iron hysteresis loss at helium temperatures for a pulsed magnet system.

The use of unsaturated iron at helium temperature has some important advantages which are often overlooked.

Table III. Heat-transport properties of support-system materials (Ref. 14).

Material	Thermal conductivity integrals (W/cm)		Reasonable design stress
	80°K to 4°K	300°K to 4°K	
<u>Tension-Rod Materials</u>			
Titanium	2.00	16.5	60 000 psi (41 500 Nt/cm ²)
304 Stainless steel	3.2	30.6	40 000 psi (27 600 Nt/cm ²)
Fiberglass epoxy	0.18	1.99	30 000 psi (20 700 Nt/cm ²)
<u>Compression-Member Materials</u>			
Fiberglass epoxy	0.18	1.99	50 00 psi in short lengths (34 600 Nt/cm ²)
Nylon	0.13	0.89	10 000 psi (6 900 Nt/cm ²)
Undusted washers, 302 stainless steel, 0.0008 in. thick	0.05	0.58	1 000 psi (6 900 Nt/cm ²)
Dusted washers, 302 stainless steel, 0.002 in thick (dust MnO ₂)	≈ 0.01	0.095	1 000 psi (6 900 Nt/cm ²)

(a) The forces between the magnet coils and the iron can be supported with minimum deflection. (These forces are unstable; the greater the deflection the greater the force.)¹⁹ This deflection can be a serious problem in long magnets such as synchrotron magnets.

(b) Aberrations due to coil-to-iron shell placement error are minimized.

(c) The iron can easily be extended beyond the magnet coil end for improved and predictable integrated field uniformity.

(d) Leads and crossover aberrations can be reduced because the leads and crossovers may be made outside the iron shield. Magnetic fields generated by leads and crossovers can be shielded by the use of mumetal.

(e) Most important magnetic forces are eliminated (unless an unshielded magnet is put adjacent to the cryostat). A gravitational support system may be used.

The advantages of having unsaturated iron at helium temperature outweigh the disadvantages when the magnet aperture is small, particularly for quadrupoles. When saturated iron is used in a magnet it is generally cold.

Cryostat Materials

Cryostat outer vacuum vessels can be made from materials such as aluminum or nonmagnetic stainless steel. Inner vessels and support members can be made of nonmagnetic stainless steel if the magnet charge

rate is low or if the magnet is not required to sustain continued pulsing. The inner vessel can be made of fiberglass epoxy, laminated structural members of nonmagnetic stainless steel, or corrugated metal-epoxy tubes when the magnet pulsing is expected to create eddy currents.

Bore Temperature

An experimental-area dipole or quadrupole can have either a warm or cold bore. Warm bores can be insulated effectively use of super-insulation and nylon netting. The insulation can be less than half an inch thick. Warm-bore cryostats should be used when the magnet is short compared with its aperture, when the bore is greater than 6 in. (15 cm), or when the magnet bore must contain a gas. The cold bore can be advantageous for long, small-bore experimental-area dipoles and quadrupole combinations provided the bore can be evacuated. Superconducting synchrotron magnets should have cold bores for the following reasons: (a) the magnets are long and heat leaks are negligible compared with other losses; (b) 70% of the vacuum-bore tube is cold--this surface cryopumps without outgassing, hence, very high vacuums in the range 10^{-9} to 10^{-10} torr are obtainable at relatively low cost; (c) the magnet cryostat cost is reduced. Cold-bore cryostats appear to be attractive for long small-bore experimental-area magnets and superconducting synchrotron magnets.

Intermediate Shields

Intermediate-temperature shields are an important part of conventional liquid pot cryostats. It is desirable to minimize all heat leaks into the Dewar because of the high capital and operating cost of liquid operation (where a liquefier is used instead of a refrigerator). This approach should be re-evaluated when magnets are to run on refrigerators, because

the cost of refrigeration is relatively low and the heat leaks into the Dewar are dominated by other loads such as leads and ac losses.

Two general methods are used to provide intermediate-temperature shield cooling. The first is to use liquid nitrogen as a coolant; the second is to use cold gas bled from the cold section of the cryostat. Two types of liquid nitrogen systems can be used:

(a) The conventional liquid reservoir and tube system, where the cryostat is almost literally surrounded by liquid nitrogen. The tank is kept full by a system which senses the liquid level in the reservoir. This method is expensive and old-fashioned, and should not be used unless it is necessary.

(b) The liquid nitrogen is bled through the shield system through a continuous tube and allowed to evaporate in the tube. The nitrogen gas flow is controlled by sensing the temperature as the gas leaves the cryostat. This system is relatively simple and direct. This system increases the cryostat price by \$1000 or more over an unshielded cryostat (price includes control system).

Gas-cooled shields are similar to the second type of nitrogen shielding system and are of comparable cost. The operating cost of gas-cooled shields is 30 to 50% of the refrigeration cost saved.

The decision to use intermediate-temperature shields and support points is purely an economic one. It is dependent on the capital and operating cost of refrigeration and whether or not operating costs are relevant. In general, one might well dispense with intermediate-temperature shields on a large experimental-area dipole and quadrupole magnet system or on a superconducting synchrotron.

PROBABLE DESIGN CONDITIONS THREE TYPES OF MAGNET CRYOSTATS

This section describes design parameters that will probably result in minimum-cost cryostat systems for the three types of magnet cryostats: (a) large-bore short cryostats for medium-energy beams from machines such as the Bevatron, (b) small-bore long cryostats for high-energy machines such as the NAL machine, and (c) high-energy superconducting synchrotron cryostats. The design parameters are highly dependent on physical and economic factors. The design parameters suggested here can be used only on dipoles and quadrupoles that are not restricted geometrically.

Each Dewar type is discussed in a separate section. These sections describe the characteristics of the cryostat, the source of heat leaks, both real and apparent, and probable design parameters that result from an analysis of cryostat characteristics, heat loads, and economic factors. Tables IV, V, and VI present a refrigeration analysis of various kinds of cryostat systems.

Bevatron-Type Beam Transport Magnet Dewar

A cryostat for dipoles and quadrupoles designed for use on machines like the Bevatron has the following characteristics:

- (a) The required aperture is large, 6 to 12 in. (15 to 30 cm).
- (b) The ratio of magnet length to aperture is generally low, for example, from 2 to 10.
- (c) Magnetic field changes can be made slowly; ac loss and eddy currents are not a problem.
- (d) Low field excitation is highly improbable.
- (e) Radiation is not usually an important factor on many secondary beams.
- (f) The magnet duty factor is likely to be low, with the magnet position to be changed relatively frequently.

(g) Iron shielding may or may not be required.

(h) Refrigeration may not be mandatory for short runs with a couple of magnets; however, helium refrigerators are definitely justified for larger magnet systems, particularly when long-duration (>2000 hr) experiments are expected.

The refrigeration load generated by a Bevatron-type Dewar results from heat leaks through the insulation, supports, and leads, as well as from gas used to cool leads and shields. A Dewar of the Bevatron type has a large surface area on both the outer portion of the Dewar and the bore tube. As a result insulation becomes more important. The support system should be capable of supporting a couple of tons in any direction as well as a rather large gravitational force due to the magnets' large mass. The heat leaks through the support system should not be any greater than for the other two Dewar types mentioned later in this report because longer support rods can be used. Direct heat leaks through leads will be small. The refrigeration required to supply gas cooling to the leads will dominate in many cases.

A minimum-cost Bevatron-type Dewar will very likely have the following design parameters:

- (a) All-metal construction is probable except for the supports (metal components should all be nonmagnetic; it should be noted that some nonmagnetic stainless steels become slightly magnetized when strained at cryogenic temperatures).
- (b) Warm-bore construction is always indicated.
- (c) If the magnet has iron shields they will be at room temperature.
- (d) Epoxy glass or titanium tension- or compression-rod support system will probably be most satisfactory.

Table IV. Estimated refrigeration requirements for a Bevatron-type Dewar.

Characteristics of the cryostat

Dewar length, 1 meter.
 Iron at room temperature.
 Cryostat warm bore 8 in. (20 cm).
 A simple foil intermediate-temperature shield in the superinsulation.
 Intermediate-temperature support points.
 Current 200 A; 1000 A through gas-cooled leads.
 Insulation vacuum superinsulation: 40 layers
 Tension-rod support 10 titanium rods 20 cm long, each supports
 4000 lb. (epoxy glass compression rods could also be used)

Refrigeration loads for the cryostat

<u>Heat source</u>	<u>Cryostat load (W)</u>	
	<u>200-A leads</u>	<u>1000-A leads</u>
Superinsulation	1.0	1.0
Tension-rod supports and necks	2.0	2.0
Gas shielding load	2.0	2.0
Electrical lead load	2-4	8-13
-----	-----	-----
Total heat load	7-9	13-18
-----	-----	-----
Purchased refrigeration capacity (transfer line load not included)	15 more for cooldown	25-30

Table V. Estimated refrigeration requirements for an NAL experimental-area Dewar.

Characteristics of the cryostat

Dewar length, 2 meters.
 Unsaturated iron at 5°K.
 Cryostat warm bore 4 in. (10 cm).
 No intermediate-temperature shields or support points.
 Current 200 A; 1000 A through gas-cooled leads.
 Insulation vacuum superinsulation: 40 layers
 Titanium rod support system: six rods 30 cm long, 4 support
 5000 lb, two support 2000 lb (epoxy glass compression rods
 could also be used).

Refrigeration required for the cryostat:

	<u>Cryostat load (W)</u>	
	<u>200-A leads</u>	<u>1000-A leads</u>
Superinsulation heat leak	1.5	1.5
Support system and neck heat leak	2.5	2.5
Gas-cooled leads	2-4	8-13
-----	-----	-----
Total heat load	6-8	12-17
-----	-----	-----
Purchased refrigeration capacity (transfer line load not included)	12 more for cooldown	20-25

Table VI. Estimated refrigeration requirements for a superconducting synchrotron Dewar.

<u>Characteristics of the cryostat and its magnet</u>			
Magnet field, 45 kG			
Cryostat cold aperture, 4 in. (10 cm)			
Conductor size, 4×10^{-4} in. (10 μ) twisted			
Repetition rate, 0.1 Hz			
Unsaturated iron (18 kG) at 5°K			
Cryostat length, dipole 10 ft (3 m), quadrupole 2 ft (0.6 cm)			
Lead current, 3000 A			
<u>Refrigeration Requirements</u>			
<u>Heat Source, both real and apparent</u>	<u>Heat loads (W)</u>		
	<u>Dipole</u>	<u>Quadrupole</u>	
Insulation heat leak (no intermediate-temperature shields, 20 layers superinsulation)	1.5	0.5	
Support-system heat leak (titanium rods), 20 000 lb support, no intermediate- temperature shield (compression rod of epoxy glass appears very attractive here)	2.0	2.0	
Heat load due to leads (only some magnets need leads to outside)	30	30	
<u>ac Losses</u>			
Superconductor losses based on LRL- measured data (Ref. 21)	75-120	20-35	
Eddy current (design value)	10-15	2-3	
Iron hysteresis, transformer steel at 18 kG	10-20	2-4	
Total ac heating	100-160	24-42	

Total heat load (transfer line heat leak not included)	With leads	135-190	60-75
	Without leads	105-160	30-45

(e) Many layers of superinsulation are economically justified.

(f) Intermediate-temperature shields probably economically justified if they are kept simple. Dewars with high-current leads run on a large refrigeration system may not need intermediate-temperature shields.

The above design parameters are subject to change as new design techniques are perfected (such as filament-winding techniques). The estimated cost for a Bevatron-type Dewar should be \$10 000 to \$15 000 per meter.¹⁵ Design improvements and mass-production techniques could reduce this price by as much as a factor of 2.

NAL-Type Beam-Transport Magnet Dewar

A dipole or quadrupole cryostat designed for use in a high energy accelerator, such as the NAL machine, has the following characteristics.

(a) The aperture of the magnet is relatively small, 2 to 4 in. (5 to 10 cm).

(b) The ratio of magnet cryostat length to aperture is large, from 10 to 50.

(c) Magnetic field changes are slow, so ac loss and eddy currents are not a problem.

(d) Low-field excitation is more probable than in the Bevatron type Dewar.

(e) Radiation is much more likely to be a problem because of higher beam intensities and energies.

(f) The magnet duty factor is low, but not so low as for lower-energy machines. The magnet position will not be permanent.

(g) Iron shielding will probably be required.

(h) Refrigeration either by conventional or supercritical means will be mandatory, for economic reasons.

(i) The number of magnets and cryostats is likely to be large.

The refrigerator will be required to overcome heat leaks through the insulation and supports as well as the effects of gas flowing through magnet leads. The surface area per unit length of this type of Dewar can be expected to be about half that for Bevatron-type Dewar. A warm-bore tube is probably justified economically except for special magnets. The support system should be capable of supporting forces of a couple of tons in any direction unless the iron is at helium temperatures. The refrigeration required for gas-cooling the leads will be a dominant part of the required refrigeration in most cases.

A minimum-cost NAL-type dipole or quadrupole Dewar will have many of the following design parameters.

(a) Nonmagnetic metals can and will be used throughout the Dewar.

(b) The magnets will be warm-bore, except when the magnets have small bores and are long and the bore can be evacuated.

(c) There are a number of strong incentives for the iron to be at helium temperature (unsaturated). This is reasonable because of the small magnet aperture, hence small iron dimensions.

(d) A simple gravitational or low-force tension-rod system can be used if the iron is cold.

(e) Multilayer insulation with no intermediate-temperature shields is economically justified in nearly all cases.

(f) The lead current chosen will be a function of magnet winding cost, refrigeration cost, and power-supply cost. One should look at the whole system before deciding.

(g) The use of supercritical refrigeration appears to be both possible and economical if low-ac-loss intrinsically stable superconductors are used to make the magnet.

A cryostat for use on NAL-type dipoles and quadrupoles should be simpler and less expensive than a Bevatron-type cryostat. Cost of \$4 000 to \$6 000 per meter for mass-produced Dewars does not seem unreasonable.

Superconducting Synchrotron Dewars

A cryostat for a high-energy superconducting synchrotron will have the following characteristics: (a)

- (a) The aperture is small, 3 to 4 in. (7 to 10 cm).
- (b) The ratio of magnet length to aperture is 5 to 10 for the quadrupoles and 25 to 50 for the dipoles.
- (c) There are strong technical and economic reasons for having a cold bore.
- (d) Various types of ac losses are the dominant refrigeration load.
- (e) Iron shielding is required for both economic and technical reasons.
- (f) Large refrigerators will be used to supply refrigeration.
- (g) The magnet duty factor is high and the magnet installation is permanent.
- (h) The magnet will be required to provide a good-quality field over the whole useful aperture at rather low excitation (during injection).
- (i) The number of identical magnets and cryostats will be large.
- (j) Radiation effects will play a role in determining cryostat design parameters.

Heat leaks through the insulation, support system, and bore tube will be at least an order of magnitude lower than the ac losses. Leads for many of the Dewars will be superconducting even though they carry large currents. Gas-cooled leads will be brought out in only few cryostats. The refrigerator load will be almost exclusively refrigeration, with no liquefaction (apparent or otherwise). Heating from the beam (which contributes to the refri-

geration load), will not be negligible in some parts of the synchrotron. Heating due to beam interactions and radiation damage to Dewar and coil components may both prove to be serious problems in synchrotron design. The dominant heat load in the Dewar will be ac losses from four sources: hysteresis and eddy currents in the superconductor, small shorts in the coils as frequency-dependent loss; conventional eddy currents in the cryostat and magnet structure, and hysteresis losses in the iron. The little data available indicates that some types of transformer steel shields will have losses substantially below those of the superconductor provided the steel is not driven beyond saturation (19 or 20 kG for medium-silicon transformer steels). Care must be taken in trying to use loss data for room-temperature iron, because the loss per cycle is 1.5 to 2 times that at helium temperature.²⁰

A minimum-cost superconducting synchrotron will have the following design parameters.

- (a) The use of metals will be limited by eddy currents. Nonmetallic structures may dominate. All metals used will be nonmagnetic, or corrugated metals can be used to a limited extent.

- (b) The magnet will have a cold bore. The interconnection between magnets will probably also be cold. Vacuum system costs are reduced substantially by use of a cold-bore system.

- (c) The iron shield should be unsaturated and cold. The advantages listed early in this paper predominate. Cooldown of the iron is not a problem--there is plenty of refrigeration available for this. The only disadvantage of cold iron is its hysteretic loss when pulsed. This loss appears to be much smaller than the superconducting ac losses.

- (d) The magnet is completely shielded from magnetic forces--a gravitational support

system can be used if expansion and contraction are considered.

(e) A multilayer insulation system with no intermediate-temperature shield should be used.

(f) Supercritical or cold light-gas refrigeration in tubes would be desirable if methods are developed to get the heat out of the coils. Conventional liquid refrigeration systems may have to be used because of the heat-transfer problem. A second J-T valve and J-T heat exchanger will become part of the magnet cryostat, the first stage of J-T expansion would occur within the refrigerator.

(g) Superconducting leads from magnet to magnet will have to be developed. Gas-cooled leads should be required only for some magnet cryostats.

(h) The cryostat outer vessel can probably be a cylinder with only a few access ports.

A cryostat for a superconducting synchrotron should be the utmost in simplicity. A reserve liquid volume (stored refrigeration) is unnecessary, hence it can be eliminated. Therefore the refrigeration system should be capable of handling all the energy of a magnet quench. Synchrotron cryostats would also be mass produced. The result is an inexpensive cryostat which we currently would estimate to cost \$1 000 to \$2 000 per meter.

SUMMARY

Large-scale use of superconducting dipoles and quadrupoles will require the production of cheap reliable cryostats. It is quite clear that the type of cryostat design used in most cryogenic laboratories of the world is both inadequate and expensive. The large-scale use of refrigeration requires a change in cryostat design in order to have a satisfactory minimum-cost cryogenic system.

As refrigerators become more reliable, more innovative cryostat designs can and should be used. The use of the refrigerator instead of liquid is an important first step toward low-cost cryogenics. The second and even bigger step will be the elimination of the reservoir of liquid helium. When both these steps are taken, low-cost helium-temperature cryogenic systems for superconducting dipole and quadrupole magnets will be a reality.

REFERENCES

1. B. Colyer, Cryogenic Problems of Superconducting Magnet Systems, in Proceedings of the International Conference on Magnet Technology, 1967 p. 624.
2. R. B. Meuser, W. H. Chamberlain, and R. E. Hintz, A Solenoid Having a Horizontal Axis and Room Temperature Aperture, in Proceedings of the 1968 British Cryogenic Conference, April 1968 (UCRL-18179, April 1968).
3. G. Del Castillo, R. J. Lari, and L. O. Oswald, Preliminary Steps for Applying Superconductors to FFAG Accelerators, in Proceedings of the 1968 Summer Study on Superconducting Devices and Accelerators, Part III, BNL-50155, July 1968, p. 1075.
4. T. R. Strobridge, D. B. Chelton, and D. B. Main, A Preliminary Analysis of Refrigeration Requirement for Superconducting Magnets in the Experimental Area of the 200-GeV Accelerator, NBS Report 9259, Oct. 31, 1966.
5. M. A. Green, G. P. Coombs, and J. L. Perry, Refrigeration for Superconducting Magnets in the 200-GeV Accelerator, Weston, Illinois (500 Incorporated, Cambridge, Mass., June 1, 1968).
6. T. R. Strobridge, Refrigeration for Superconducting and Cryogenic Systems, IEEE

- Trans. Nucl. Sci. NS-16 [3], 1104
(June 1969).
7. M. A. Green, Refrigeration of Superconducting Magnets, UCRL-19758, April 1970.
 8. H. H. Kolm, M. J. Leopold, and R. D. Hay, Heat Transfer by the Circulation of Supercritical Helium, Adv. Cryog. Eng. **11**, 539 (1965).
 9. S. C. Collins, Refrigeration at Temperatures Below the Boiling Point of Helium, in Proceedings of the 1969 Summer Study on Superconducting Devices and Accelerators, Part I, BNL-50155, July 1968, p. 59.
 10. H. Brechna, Materials and Conductor Configurations in Superconducting Magnets, in Proceedings of the 1968 Summer Study on Superconducting Devices and Accelerators, Part II, BNL-50155, July 1968, p. 478.
 11. M. A. Green, Heat Deposition and Heat Transfer in a Superconducting Thin Septum Magnet, UCID-3168, April 1968.
 12. Michael A. Green, The First Year of Operation of the LRL Liquefier, UCID-3429 (to be issued).
 13. Michael A. Green, Operating Procedure for the LRL Liquefier, UCID-3428, Dec. 23, 1969.
 14. R. B. Scott, Cryogenic Engineering (D. Von Nostrand Co., New York, 1959).
 15. Michael A. Green, The Transport of Energy by Radiation and Conduction Through a Stack of Parallel Plates, LRL Engineering Note M4061, June 1969.
 16. R. A. Kilpatrick, R. B. Meuser, and W. Vogen (LRL-Berkeley), private communication on the cost of magnet cryostats and their components.
 17. W. H. Chamberlain, R. A. Kilpatrick (LRL-Berkeley) private communication on the tension-rod and compression-rod support systems.
 18. R. B. Meuser, Magnetic Shields for Superconducting Bending and Quadrupole Magnets, UCRL-18318, June 1968.
 19. K. Halbach, Fields and First-Order Perturbation Effects in Two-Dimensional Conductor-Dominated Magnets, UCRL-18947, July 1969.
 20. A. McInturff and J. Claus, Low-Temperature Iron Measurements, Brookhaven National Laboratory report (to be published).
 21. Ferd Voelker (LRL-Berkeley), on LRL ac loss measurement in fine stranded Nb-Ti superconductor.

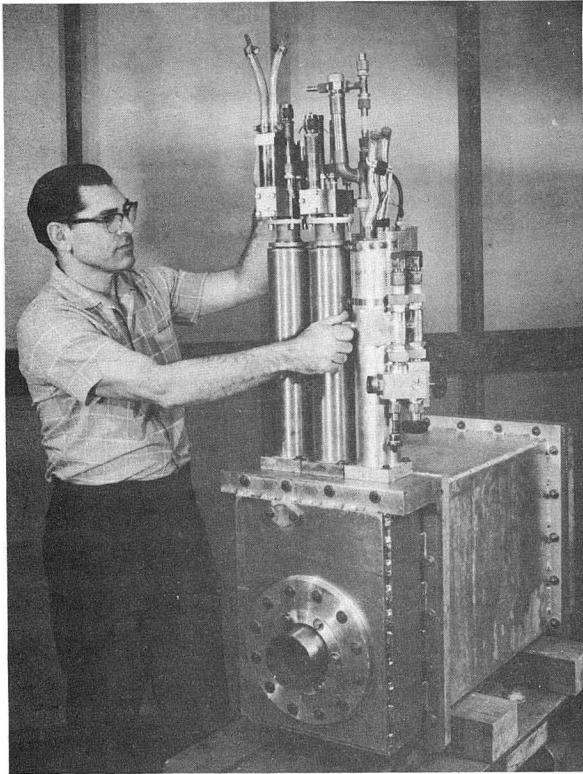

Fig. 1. Completed LRL warm-bore Zorba superconducting magnet cryostat, used on a 184-inch cyclotron experiment.
CBB-684-2004

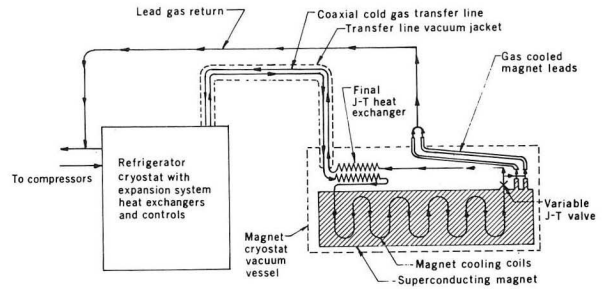

Fig. 3. A superconducting magnet with a supercritical helium refrigeration system.
XBL-708-6232

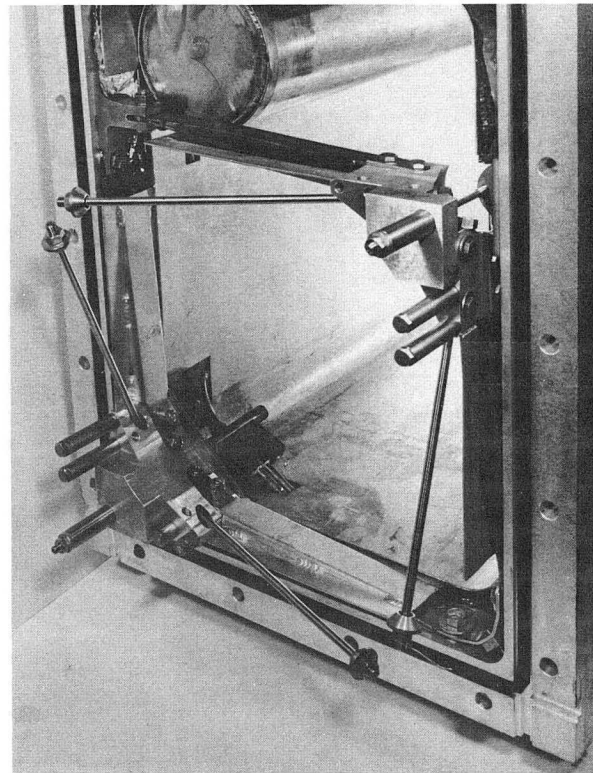

Fig. 4. Tension-rod support system for the Zorba superconducting magnet cryostat. The nitrogen shield and gas cooling points are shown.
XBB-681-184

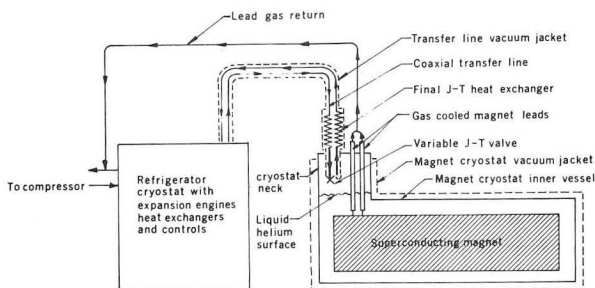

Fig. 2. A superconducting magnet with a conventional refrigeration system.
XBL-708-6233

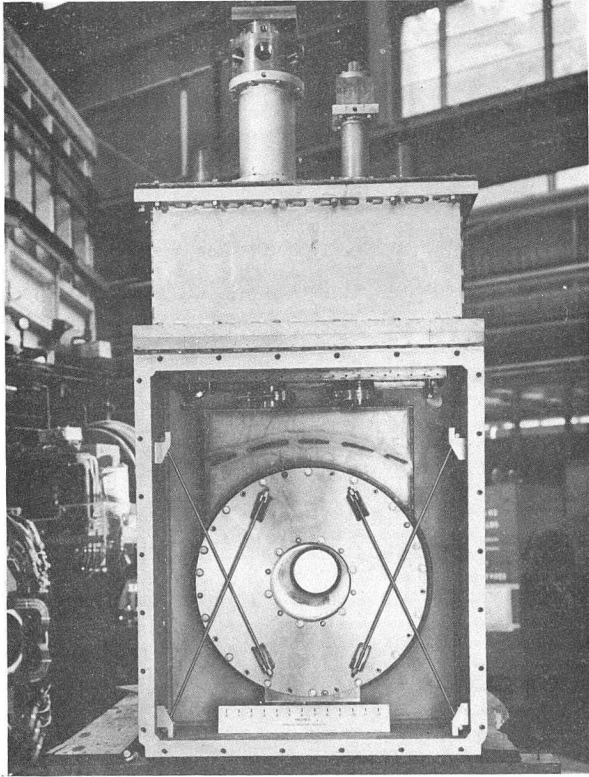
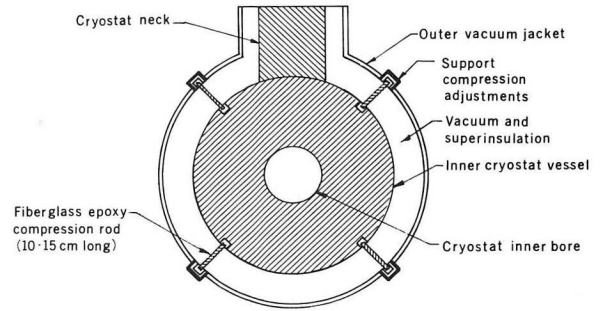
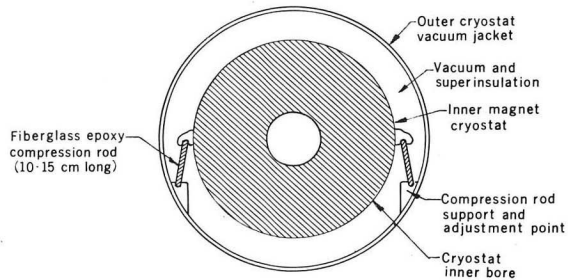

Fig. 5. Simplified tension-rod support system for a LRL superconducting dipole magnet cryostat. XBB-6912-8300



a) Even position support system



b) Gravitational force support system

Fig. 7. Typical compression-rod support systems. XBL-708-6234

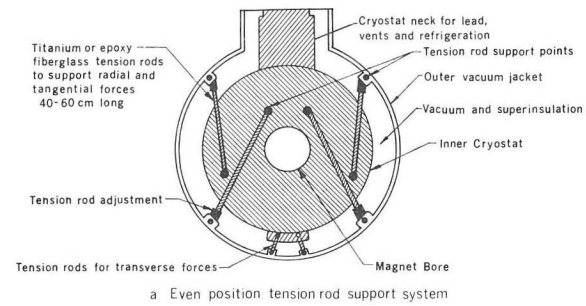

a) Even position tension rod support system

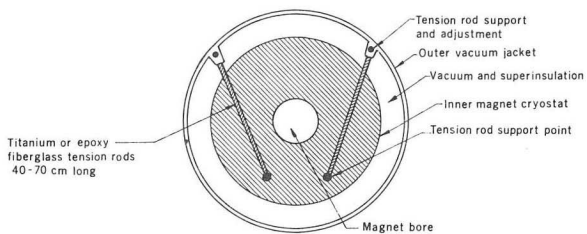

b) Gravitational force tension rod support system

Fig. 6. Typical tension-rod support systems. XBL-708-6235

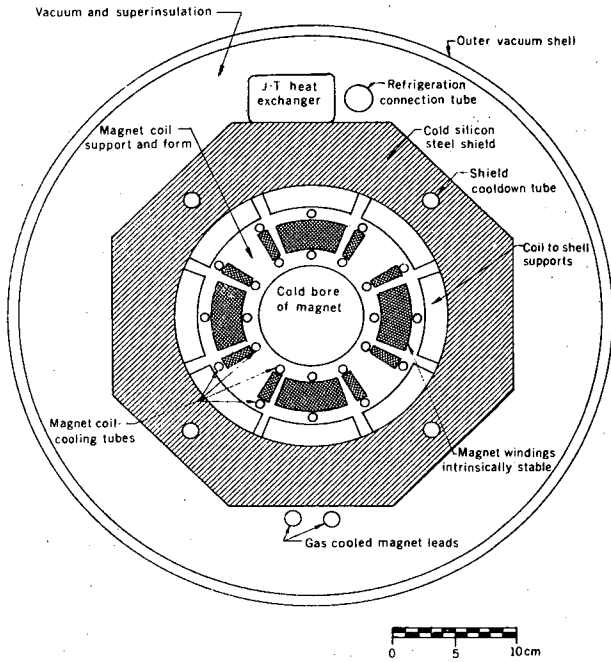

Fig. 8. Cross section of a supercritical cooled quadrupole. XBL-708-6236

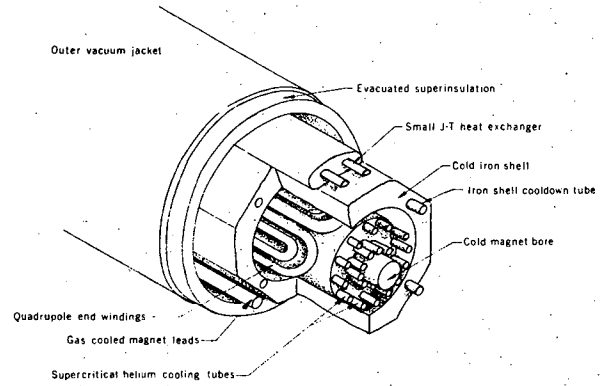

Fig. 9. Cutaway view of the end of a supercritical cooled quadrupole. XBL-708-6237

LEGAL NOTICE

This report was prepared as an account of Government sponsored work. Neither the United States, nor the Commission, nor any person acting on behalf of the Commission:

- A. Makes any warranty or representation, expressed or implied, with respect to the accuracy, completeness, or usefulness of the information contained in this report, or that the use of any information, apparatus, method, or process disclosed in this report may not infringe privately owned rights; or*
- B. Assumes any liabilities with respect to the use of, or for damages resulting from the use of any information, apparatus, method, or process disclosed in this report.*

As used in the above, "person acting on behalf of the Commission" includes any employee or contractor of the Commission, or employee of such contractor, to the extent that such employee or contractor of the Commission, or employee of such contractor prepares, disseminates, or provides access to, any information pursuant to his employment or contract with the Commission, or his employment with such contractor.

TECHNICAL INFORMATION DIVISION
LAWRENCE RADIATION LABORATORY
UNIVERSITY OF CALIFORNIA
BERKELEY, CALIFORNIA 94720