

UC Berkeley

UC Berkeley Electronic Theses and Dissertations

Title

I. Measuring and Reducing Stress and Surface Roughness in IBAD MgO Films and II. Developing Tools to Measure Transfer in Undergraduate Chemistry Students

Permalink

<https://escholarship.org/uc/item/3t5190jm>

Author

Antonakos, Cory Dale

Publication Date

2016

Peer reviewed|Thesis/dissertation

I. Measuring and Reducing Stress and Surface Roughness in IBAD MgO Films
and
II. Developing Tools to Measure Transfer in Undergraduate Chemistry
Students

by

Cory Dale Antonakos

A dissertation submitted in partial satisfaction of the
requirements for the degree of
Doctor of Philosophy
in
Chemistry
in the
Graduate Division
of the
University of California, Berkeley

Committee in charge:

Professor Frances Hellman, Co-chair
Professor Angelica Stacy, Co-chair
Assistant Professor Tanja Cuk
Professor Mark Asta

Summer 2016

**I. Measuring and Reducing Stress and Surface Roughness in IBAD MgO Films
and
II. Developing Tools to Measure Transfer in Undergraduate Chemistry
Students**

Copyright 2016
by
Cory Dale Antonakos

Abstract

- I. Measuring and Reducing Stress and Surface Roughness in IBAD MgO Films
and
II. Developing Tools to Measure Transfer in Undergraduate Chemistry Students

by

Cory Dale Antonakos

Doctor of Philosophy in Chemistry

University of California, Berkeley

Professor Frances Hellman, Co-chair

Professor Angelica Stacy, Co-chair

I. MgO may be grown with a biaxial texture onto an amorphous substrate with the use of ion beam assisted deposition (IBAD). This MgO film may then be used as a platform on which to grow epitaxial films on an amorphous membrane for characterization purposes. However, the IBAD MgO film is stressed, causing buckles in the amorphous membrane and problems with further film growth on the IBAD MgO. This dissertation work explores the source of this film stress and develops methods to relax the stress and reduce surface roughness with annealing and increased growth temperature. It is determined that annealing and increased growth temperature coupled with a higher ion-to-atom ratio (IAR) during film growth reduce stress and surface roughness sufficiently to use even thinner IBAD MgO films as an intermediate layer between an amorphous membrane and epitaxial film.

II. Much of the existing literature on knowledge transfer concludes that transfer is rare and does not occur spontaneously. However, studies supporting that transfer is rare often use methods that focus on binary success or failure to solve a problem correctly and do not analyze thought process. This dissertation work aims at developing transfer questions that allow open-ended responses, developing a method of analysis for these responses that looks for transfer in the problem-solving process, and assessing the methodology itself and its sensitivity, validity, and utility as a general transfer measurement technique for use across a broad range of expertise levels in chemistry.

Detailed analysis of responses to each transfer question show that some transfer questions are more effective at distinguishing between expertise levels while also allowing responders of all levels to show knowledge transfer. Simpler questions that are more accessible to students of introductory chemistry proved the most useful at eliciting a range of responses that correlate with expertise level while still showing some degree of transfer in all levels of responders. More challenging questions with complex systems and common misconceptions

are too advanced for lower level undergraduates to show knowledge transfer, but may be useful to show transfer in advanced undergraduates and experts.

To Gia gia

Contents

Contents	ii
List of Figures	iv
List of Tables	x
1 Introduction and Background	1
1.1 Introduction	1
1.2 History of IBAD development	2
1.3 Details of past work on IBAD MgO	4
1.4 Stress, strain, and structural distortion in IBAD MgO	5
1.5 Growth temperature and annealing to control stress and surface roughness	7
2 Growth and in-situ characterization of IBAD MgO	9
2.1 Basics of MgO growth	9
2.2 Ion gun electrical deposition	10
2.3 Ion to atom ratio	11
2.4 RHEED monitoring	15
2.5 IBAD and homoepitaxial MgO growth	15
3 X-ray diffractometry of IBAD MgO	20
3.1 Introduction	20
3.2 Details of silver growth	21
3.3 XRD of Ag on IBAD MgO	21
4 Stress and surface roughness in IBAD MgO	27
4.1 Introduction to stress measurements	27
4.2 Film stress measurements using the Flexus	28
4.3 Results of film stress measurements	29
4.4 Results of annealing on film stress	35
4.5 Results of homoepitaxial layer growth temperature on film stress	36
4.6 Effect of growth conditions and annealing on surface roughness of IBAD MgO films	36

5	Conclusion	43
5.1	Conclusion	43
6	Introduction and Background	44
6.1	Transfer in science education research	44
6.2	Previous research on transfer	44
6.3	Improving measurement methods for transfer	46
6.4	Goals of this work	47
6.5	Summary	48
7	Methods: Development and testing of tools to measure transfer	50
7.1	Introduction	50
7.2	Transfer question design	50
7.3	Testing transfer questions	53
7.4	Evaluating answers to transfer questions	53
7.5	Expected response range	57
7.6	Summary	58
8	Results: Sensitivity of transfer questions	59
8.1	Introduction	59
8.2	Summary of evaluated responses	59
8.3	Qualitative analysis of each question	69
8.4	Questions eliciting expected response range	81
8.5	Questions eliciting unexpected response range	82
8.6	What makes a more or less useful and sensitive transfer question?	84
8.7	Summary	87
9	Conclusion and Future Work	88
9.1	Conclusion	88
9.2	How can these findings be used by researchers and educators?	89
9.3	Future work	89
	Bibliography	90

List of Figures

- 1.1 Microcalorimetry device using an amorphous SiN platform to thermally isolate the sample [13]. An example of a measurement platform on which an epitaxial film cannot be directly grown. The largest green-colored square in this image is the 1 cm x 1 cm silicon frame. The 0.5 cm x 0.5 cm amorphous membrane can be seen as the turquoise-colored square inside the larger green-colored square. The red 0.25 x 0.25 cm square in the center is the sample itself. The gray-colored pieces are the device's electronics: heater and three different thermometers used to measure heat capacity. Image courtesy of Dr. Daniel Queen. 3
- 1.2 Cartoon showing difference between single crystal, biaxially textured, uniaxially textured, and randomly oriented thin films. Uniaxial texture applies to films grown on an amorphous surface. This is what the MgO would look like without the ion beam's intervention. This is also what most films would look like when grown onto an amorphous surface, and demonstrates the need for the IBAD MgO intermediate layer to grow epitaxial thin film samples on amorphous membrane platforms. Biaxial texture is what the ion beam induces in the MgO and represents the IBAD MgO thin films. Single crystal also has fixed orientation both in and out of plane, but does not have the grain boundaries seen in the biaxially textured film. Single crystal quality is seen in commercially purchased substrates. This image came from the PhD dissertation of Dr. James Randal Groves, Ion-beam Texturing At Nucleation: Investigation of the Fundamental Mechanism of Biaxial Texture Development In Ion Beam Assisted Deposition and Applications. 2010. [20] 4

1.3	Phase-contrast optical microscope image of 30 nm amorphous SiN membrane with IBAD MgO deposited. The flat red areas, both narrow and wide, are thick Pt layers (with IBAD MgO) and are flat; the colorful patterns between are areas of membrane with IBAD MgO on them, showing significant tensile strain. The membrane is the platform of a nanocalorimetry device. This is a smaller version of the device shown in Figure 1.1, used for measuring heat capacity of small thin film samples. The wrinkles in the membrane are caused by the strain in the IBAD MgO film. This demonstrates the problem that IBAD MgO's in-plane strain presents for its use for growing epitaxial thin films on amorphous membranes. Image taken by Dr. Dave W. Cooke: Strain Fields of a Buckled Silicon Nitride Membrane APS March Meeting 2010, 3/17/10, Portland, OR.[10]	6
2.1	(Original figure modified from IBS 250 Power Supply Technical Manual. Veeco Instruments, Inc. 2002.) [36] Cross sectional drawing of 3 cm DC ion source. This drawing shows what each component looks like and its physical arrangement inside the ion gun.	11
2.2	(Original figure modified from IBS 250 Power Supply Technical Manual. Veeco Instruments, Inc. 2002.) [36] Electrical schematic diagram of the 3 cm DC ion source and its connections to the 250 IBS power supply. This diagram shows the outputs and readings on the power supply, and how they correspond to the electrical function of the ion source.	12
2.3	RHEED diffraction pattern for amorphous $\text{Si}_x\text{N}_{(1-x)}$ substrate.	16
2.4	RHEED diffraction pattern for polycrystalline MgO grown onto amorphous $\text{Si}_x\text{N}_{(1-x)}$	17
2.5	RHEED diffraction pattern for IBAD MgO only grown onto amorphous $\text{Si}_x\text{N}_{(1-x)}$	18
2.6	RHEED diffraction pattern for homoepitaxial MgO grown on top of biaxially textured IBAD MgO grown on amorphous $\text{Si}_x\text{N}_{(1-x)}$	19
3.1	Omega-2-theta XRD scan of 50 nm Ag films grown on top of 1 nm IBAD MgO with no homoepitaxial layer.	22
3.2	Omega-2-theta XRD scan of 50 nm Ag films grown on top of 1 nm IBAD + 11 nm homoepitaxial MgO.	23
3.3	Omega-2-theta XRD scan of 50 nm Ag films grown on top of single crystal (100) MgO substrates.	24
3.4	360° phi XRD scan of the 111 Bragg reflection of 50 nm Ag films grown on top of IBAD MgO + 11 nm homoepitaxial MgO.	25
3.5	360° phi XRD scan of the 111 Bragg reflection of 50 nm Ag films grown on top of commercial single crystal (100) MgO substrates.	26

4.1	Film stress in as-grown state and after annealing, measured by radius of wafer curvature parallel to projection of ion beam during growth. Plot shows three different samples: IBAD MgO film only, IBAD + 5 nm homoepitaxial MgO grown at 350°C, and IBAD + 15 nm homoepitaxial MgO grown at 350°C. Error bars determined by standard error of mean value from 3 to 5 measurements are included in plots, though most are very small and inside marker symbols.	30
4.2	Film stress in as-grown state and after annealing, measured by radius of wafer curvature perpendicular to projection of ion beam during growth. Plot shows three different samples: IBAD MgO film only, IBAD + 5 nm homoepitaxial MgO grown at 350°C, and IBAD + 15 nm homoepitaxial MgO grown at 350°C. Error bars determined by standard error of mean value from 3 to 5 measurements are included in plots, though most are very small and inside marker symbols.	31
4.3	Cartoon showing wafer bow direction as a result of compressive film stress. Because the atoms in a film under compressive stress are squeezed too close together with an excess of atoms per unit area, interatomic Coulomb repulsions cause the film to bend the wafer outward.	32
4.4	Cartoon showing wafer bow direction as a result of tensile film stress. Because the atoms in a film under tensile stress are spread too far apart from each other with a deficit of atoms per unit area, interatomic Coulomb attraction causes the film to bend the wafer inward.	33
4.5	Film stress change with annealing and additional change of growth temperature, measured by radius of wafer curvature parallel to projection of ion beam during growth. Plot shows five different samples: IBAD MgO film only, IBAD + 5 nm homoepitaxial MgO grown at 350°C, IBAD + 15 nm homoepitaxial MgO grown at 350°C, IBAD + 15 nm homoepitaxial MgO grown at 425°C, and IBAD + 15 nm homoepitaxial MgO grown at 500°C. Films with homoepitaxial MgO grown at 425 and 500°C were not annealed after growth. Error bars determined by standard error of mean value from 3 to 5 measurements are included in plots, though most are very small and inside marker symbols.	37
4.6	Film stress change with annealing and additional change of growth temperature, measured by radius of wafer curvature perpendicular to projection of ion beam during growth. Plot shows five different samples: IBAD MgO film only, IBAD + 5 nm homoepitaxial MgO grown at 350°C, IBAD + 15 nm homoepitaxial MgO grown at 350°C, IBAD + 15 nm homoepitaxial MgO grown at 425°C, and IBAD + 15 nm homoepitaxial MgO grown at 500°C. Films with homoepitaxial MgO grown at 425 and 500°C were not annealed after growth. Error bars determined by standard error of mean value from 3 to 5 measurements are included in plots, though most are very small and inside marker symbols.	38

4.7	AFM image of IBAD only MgO film surface A. after growth, no annealing and B. after 500°C anneal for 30 minutes. It can be seen that the range of height of the vertical features decreases after the anneal. Visually, it can also be seen that the diameter of the grains decreases after the anneal. The rms roughness values were calculated from lateral profiles across the centers of each image.	39
4.8	AFM image of IBAD + 5 nm homoepitaxial MgO film surface A. after growth, no annealing but homoepitaxial layer grown at 350°C and B. after 500°C anneal for 30 minutes. It can be seen that the range of height of the vertical features decreases after the anneal. The rms roughness values were calculated from lateral profiles across the centers of each image.	40
4.9	AFM image of IBAD + 15 nm homoepitaxial MgO film surface A. after growth, no annealing but homoepitaxial layer grown at 350°C and B. after 500°C anneal for 30 minutes. It can be seen that the range of height of the vertical features decreases after the anneal. The rms roughness values were calculated from lateral profiles across the centers of each image.	41
4.10	Roughness values for three different IBAD MgO films as-grown and after each post-growth anneal. Samples include IBAD MgO only, IBAD + 5 nm homoepitaxial MgO grown at 350°C, and IBAD + 15 nm homoepitaxial MgO grown at 350°C. Roughness calculated from lateral profiles of AFM images. Error bars determined by standard error of mean value from 2 measurements are included in plots, though most are very small and inside marker symbols.	42
7.1	Bloom's Taxonomy [2]: a hierarchy of educational learning goals with increasing depth and complexity. The first three (remember, understand, apply) are observed in responses to transfer questions in this work. The higher level learning goals of the three are observed with increasing frequency as expertise level of responder increases.	55
8.1	Percentage of responses showing recognition of applicable chemical principle needed to answer the question, separated by question (x axis) and level of expertise of responder (Introductory Chemistry student, Organic Chemistry student, field expert). A significant percentage of respondents in each level of expertise were able to recognize the applicable chemical principle for each question. That responders with a range of expertise levels are able to recognize the applicable chemical principle makes these questions useful for showing and measuring transfer across a range of expertise levels. However, it can still be seen that percentage of responses showing recognition of the applicable chemical principle increases as expertise level increases.	61
8.2	Percentage of responses explicitly showing understanding of applicable chemical principle needed to answer the question, separated by question (x axis) and level of expertise of responder (Introductory Chemistry student, Organic Chemistry student, field expert).	62

- 8.3 Percentage of responses showing application of chemical principle needed to answer the question, separated by question (x axis) and level of expertise of responder (Introductory Chemistry student, Organic Chemistry student, field expert). Note that application of a chemical principle does not necessarily mean responder applied the correct chemical principle, only that he or she made a connection between a chemical principle and the macroscale observation described in the question. 63
- 8.4 Percentage of responses showing correct application of chemical principle needed to answer the question, separated by question (x axis) and level of expertise of responder (Introductory Chemistry student, Organic Chemistry student, field expert). This category is the closest measure of the responder's complete and correct answer to the question. 64
- 8.5 Percentage of responses showing logical flow and connection of ideas. This may also be described as thinking like a scientist. Separated by question (x axis) and level of expertise of responder (Introductory Chemistry student, Organic Chemistry student, field expert). 65
- 8.6 Percentage of responses using a nanoscale view to answer the question. This may also be described as thinking like a chemist. Separated by question (x axis) and level of expertise of responder (Introductory Chemistry student, Organic Chemistry student, field expert). 66
- 8.7 Percentage of responses using a structural view to answer the question. A structural view includes a nanoscale view with the addition of description of molecular structure and bonding. Separated by question (x axis) and level of expertise of responder (Introductory Chemistry student, Organic Chemistry student, field expert). Notice that not all questions are included in this figure, as some questions did not elicit a structural view from any responders. 67
- 8.8 Percentage of responses showing a misconception in the answer to the question. Separated by question (x axis) and level of expertise of responder (Introductory Chemistry student, Organic Chemistry student, field expert). Note that only the three questions that elicited common misconceptions are included in this figure. 68

- 8.9 Model of transfer question attributes. This model summarizes and describes the minimum levels of expertise capable of showing transfer when different levels of complexity of question are asked as transfer tasks. The first step shown in the plot shows the type of question in which Introductory chemistry students are capable of showing transfer. The next step shows the type of question in which Organic students, and likely other intermediate and advanced level undergraduates, are capable of showing transfer. The highest step describes the type of complex transfer question in which only field experts show a significant amount of knowledge transfer. The x-axis, while showing the specific levels of students and experts measured in this work may also show more continuously an increase in content knowledge as well as time on task and practice thinking like a chemist as expertise level increases. The y-axis shows an increase in the progress the responder makes in his or her response to the transfer question along the transfer pathway, frequency of logical flow, and frequency of nanoscale view used by the responder. 86

List of Tables

2.1	Parameters used for gas flow, chamber pressure, and voltage and current settings of ion gun components.	13
3.1	FWHM of Ag (200) peaks	22

Acknowledgments

Thank you first and foremost to Frances and Angy. Graduate school is hard, and I imagine mentoring a student through it is no easy task. There is a great variety of advisors and mentors out there, and I feel incredibly fortunate to have the two that I did. Frances pushed me to evolve into a researcher by allowing me to figure things out on my own when I could and providing guidance and expertise when necessary. I appreciated the evolution of our relationship as I came to a better understanding of academic research. I am especially grateful that she allowed me to take control of my own research project. The best mentors recognize and support the independence, individuality, and nuances of their mentees. Thank you Frances for providing comfort without hand-holding and supporting me in making this work my own.

Angy believed in me and supported me from day one, even and especially when I did not believe in myself. Perhaps most importantly, she proposed to me an alternative path to keep me from quitting when I had all but decided I was going to. I appreciate and enjoyed her guidance through my chemistry education research. This dissertation would not be here without her support.

Thank you to Norman Phillips and Yuri Suzuki for supporting me through the qualifying exam process. Thank you to Mark Asta for supporting me through my dissertation. And thank you to Tanja Cuk for sticking with me through both my qualifying exam and through my dissertation completion.

Thank you to Dr. Vertes for supporting me as an undergraduate developing a thirst for research and through my transition into graduate school.

As I hope more people come to understand, science is never done alone. I have relied on countless people throughout this dissertation work. All of my labmates in the Hellman Lab, the SESAME group, staff and members of the Nanolab, other professors, postdocs, graduate students, undergraduates, and technicians outside of my own groups, friends, and family. I've only been able to do my work by standing on the shoulders of others before me - Daniel Queen, Dave Cooke, and Randy Groves certainly paved the way with their work so that I could do mine. Daniel was especially supportive in my early years in the Hellman lab, teaching me to run Cp measurements and answering all of my questions while I studied for my qualifying exam. Chloe spent months in the Nanolab with me, teaching me how to make the Cp devices. She was a great mentor and friend as I was trying to get my research off the ground. Hilary taught me to question things with confidence and communicate clearly and fearlessly. She was also a great partner to have in my later years navigating endless lab maintenance tasks while trying to move forward with research. Thank you Alex for teaching me to use the AFM and making days in the lab more fun. The rest of the Hellman lab offered support in both their expertise and their friendship: Dave, Zoe, Julie, Laura, Michalis, Simca, Siming, and Manel. Thank you most especially to Cathy Bordel for your unwavering assistance with e-beam maintenance, perseverance with the IBAD MgO growths, and your constant overall support, positivity, expertise, mentorship and friendship. The lab was always a much better place with you in it.

Thank you to the whole SESAME group for filling my Fridays in grad school with your Chem Ed expertise, positivity, laughter, and support.

Graduate school was as much of an emotional challenge as a mental challenge. Thank you to all of my friends and family for your support through the ups and downs of this journey. Thank you Mom, Dad, Brandon, and Tasha for loving and accepting all of me all the time, for pushing me through an academically rigorous education and helping me grow into a person with enough confidence to take a stab at this PhD. Thank you to all of my friends who rode the grad school roller coaster with me. The journey would have been much more drab without you all. Thank you Jen and Sara for your empathy, encouragement, helping make Berkeley my home, and providing stability when I lost my own. Thank you Alice, Brooke, Rachel, Kyle, Jes, and Domino for making me feel sane and normal through every grad school struggle.

Words cannot do justice to the value of Keenan's love, support, and reliability throughout this journey and into the next one. Thank you for sticking by me always.

Chapter 1

Introduction and Background

1.1 Introduction

Thin films materials hold interest in the scientific community due to unique behavior distinct from their bulk counterparts. The novel physical phenomena observed in thin films are interesting from a fundamental physics perspective and also useful in engineering new micro- and nano-scale devices and technologies such as those developed for high-density computer processing and memory storage.

Typically, in order to create a high quality film with few defects including grain boundaries, an epitaxial film is needed, requiring a single crystal substrate of suitable lattice constant. The substrate controls the film's structure by causing it to grow epitaxially with in-plane grain alignment. However, several methods used to study thin films rely on an amorphous membrane sample stage. These methods include X-ray and/or electron transmission measurements as well as measurements of thermal properties such as temperature-dependent phenomena and specific heat capacity (Figure 1.1). Additionally, there is a need to grow thin films on polycrystalline tape. Using amorphous membranes or polycrystalline tape limits structural control of the sample. Materials deposited will develop either an amorphous structure or a polycrystalline structure with no in-plane grain alignment.

Over the past two decades, a new method for thin film growth has emerged, initially motivated by its use as an intermediate platform for depositing high T_c superconducting materials such as yttrium barium copper oxide (YBCO) onto inexpensive substrates [37]. This growth method employs a 750 eV beam of Ar^+ cations to create biaxial texture in MgO (Figure 1.2) grown onto an amorphous substrate. This technique, called ion beam assisted deposition (IBAD) removes the need for a single crystal substrate to create a single crystal thin film. Work to date has focused on MgO because of its usefulness as a substrate on which many materials can be grown epitaxially; the technique can likely be extended to many other materials.

Without the use of the ion beam, MgO grows (100) out-of-plane, due to low surface energy, but will be randomly oriented in-plane. During an IBAD growth, the Ar^+ cations bombard

the film at a fixed angle of 45° during deposition, producing a uniform in-plane film texture through a channeling effect along the (202) direction. In a single crystal MgO film oriented (100) both in-plane and out-of-plane, the largest channels occur along the (202) direction. Because IBAD MgO has a (100) texture both out-of-plane and in-plane, thin films of interest that can grow epitaxially on (100) single crystal MgO substrates can also grow epitaxially on IBAD MgO.

The IBAD growth technique remains in a state of development and presents scientists with an array of new phenomena to understand. This dissertation work seeks to understand and control an IBAD MgO film's unique crystal structure and its response to growth temperature, thickness, and most importantly, post-growth heat treatment.

1.2 History of IBAD development

IBAD was initially developed to create biaxially textured yttria-stabilized zirconia (YSZ) films. However, these IBAD YSZ films required long processing times and thicknesses close to 500 nm to achieve in-plane alignment. IBAD MgO films were then developed with thicknesses as low as 10 nm achieving better in-plane alignment than the thicker IBAD YSZ films [16].

The IBAD technique has so far been developed to grow biaxially textured films of only very few materials - namely YSZ and MgO - onto amorphous surfaces. There are a multitude of other materials of interest to be studied using amorphous platform measurements. The IBAD technique, therefore, is not used for the film of interest itself. The IBAD YSZ and MgO films are instead used as an intermediate layer between the amorphous platform and the film of interest. The IBAD films serve as a substrate onto which to grow an epitaxial film to be measured, so it is advantageous for the IBAD film to be as thin as possible. Therefore, IBAD MgO, requiring only 10 nm, is more promising for applications than IBAD YSZ, which requires 500 nm. Furthermore, as shown in this dissertation work, the actual IBAD MgO layer need only be 1 nm thick. The other 9 nm is a homoepitaxial layer of MgO grown on top to improve surface quality.

FeRh thin films are studied using amorphous membrane platforms for heat capacity measurements as well as temperature-dependent X-ray transmission measurements [3][9]. FeRh thin films exhibit a first-order magnetic phase transition just above room temperature. Heat capacity and temperature-dependent X-ray transmission measurements help us further understand the nature of this unique phase transition. FeRh thin films grow epitaxially on (100) MgO single crystal substrates, as well as on IBAD + homoepitaxial MgO [8]. IBAD + homoepitaxial MgO allows us to study epitaxial FeRh thin films using heat capacity and temperature-dependent X-ray transmission measurements. Several studies on this magnetic phase transition in FeRh thin films using amorphous membrane platforms have motivated my interest in the growth of IBAD MgO.

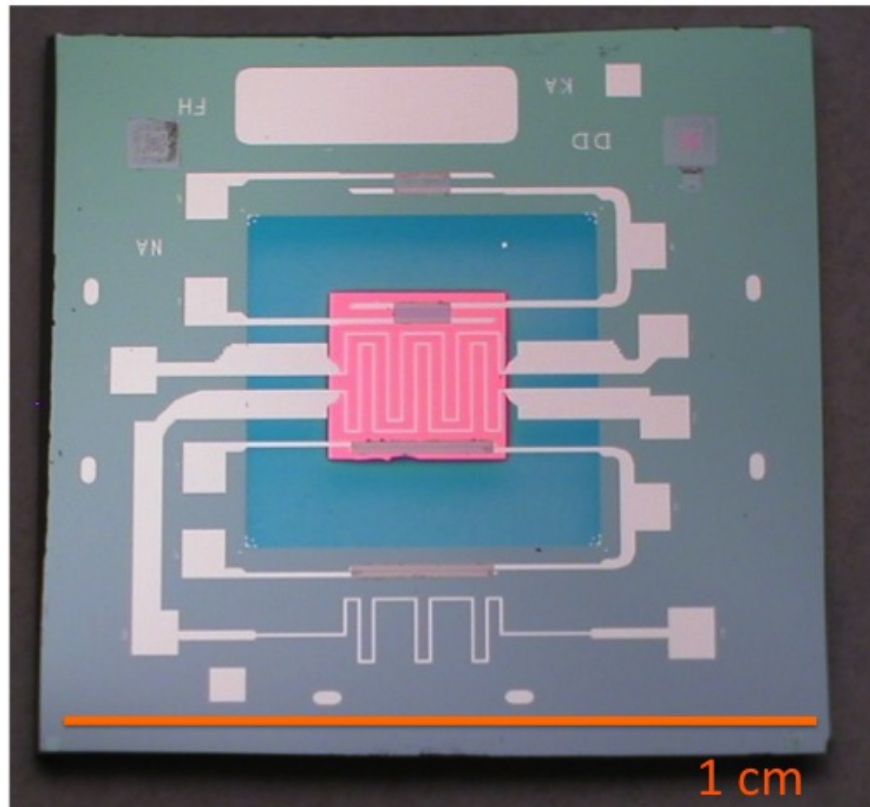

Figure 1.1: Microcalorimetry device using an amorphous SiN platform to thermally isolate the sample [13]. An example of a measurement platform on which an epitaxial film cannot be directly grown. The largest green-colored square in this image is the 1 cm x 1 cm silicon frame. The 0.5 cm x 0.5 cm amorphous membrane can be seen as the turquoise-colored square inside the larger green-colored square. The red 0.25 x 0.25 cm square in the center is the sample itself. The gray-colored pieces are the device's electronics: heater and three different thermometers used to measure heat capacity. Image courtesy of Dr. Daniel Queen.

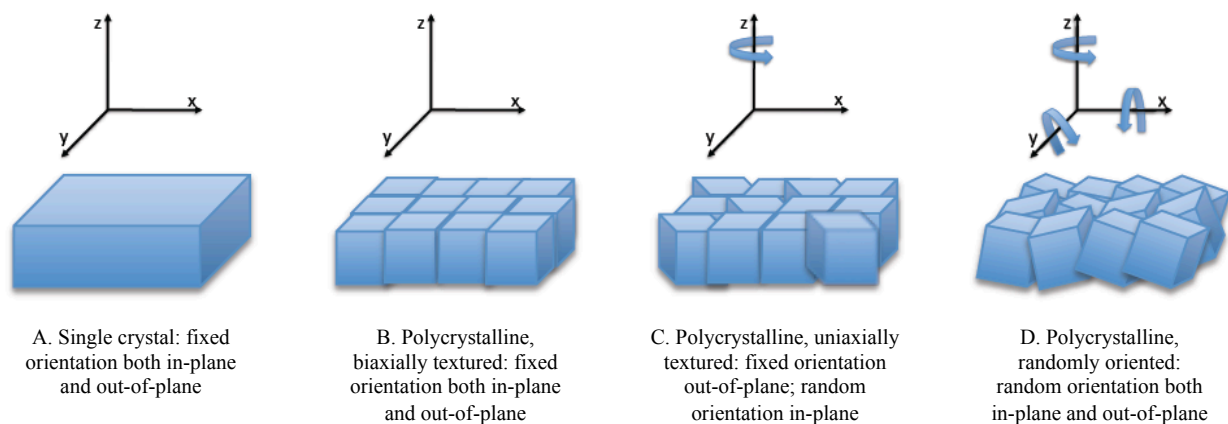

Figure 1.2: Cartoon showing difference between single crystal, biaxially textured, uniaxially textured, and randomly oriented thin films. Uniaxial texture applies to films grown on an amorphous surface. This is what the MgO would look like without the ion beam's intervention. This is also what most films would look like when grown onto an amorphous surface, and demonstrates the need for the IBAD MgO intermediate layer to grow epitaxial thin film samples on amorphous membrane platforms. Biaxial texture is what the ion beam induces in the MgO and represents the IBAD MgO thin films. Single crystal also has fixed orientation both in and out of plane, but does not have the grain boundaries seen in the biaxially textured film. Single crystal quality is seen in commercially purchased substrates. This image came from the PhD dissertation of Dr. James Randal Groves, Ion-beam Texturing At Nucleation: Investigation of the Fundamental Mechanism of Biaxial Texture Development In Ion Beam Assisted Deposition and Applications. 2010. [20]

1.3 Details of past work on IBAD MgO

In most previous work, IBAD MgO is deposited onto an amorphous SiN surface. Without the use of the ion beam, MgO grows (100) out-of-plane, due to low surface energy. However, MgO will grow randomly oriented in-plane. During IBAD deposition, the MgO film is bombarded with a 750 eV Ar^+ ion beam to induce biaxial texture in the MgO. The ion beam is oriented 45° relative to the surface of the substrate, causing the MgO to grow with (100) in-plane orientation [20]. The (100) in-plane orientation is achieved through a channeling effect of the Ar^+ ion beam through the (202) channels in (100) MgO. The (202) direction exhibits the largest channels in (100) in-plane MgO. However, the mechanism for the nucleation of texture is not well understood. Work has been done to study the mechanism of IBAD's texture development [20], but a mature, well-supported model has not yet been formed. Approximately 10 nm of IBAD MgO was grown at room temperature, followed by a homoepitaxial MgO layer grown at 300°C without the ion beam. The homoepitaxial layer improves the quality of the MgO surface, creating a better substrate onto which to grow an

epitaxial thin film. For application purposes, the homoepitaxial layer to date has been grown as thin as 15 nm [37]. However, thicker homoepitaxial layers, up to 100 nm, have been grown to characterize the IBAD MgO film using X-ray diffraction (XRD). XRD measurements have shown that the in-plane texture of IBAD + homoepitaxial MgO comes close to the quality of single crystal MgO [19]. In-situ monitoring of the IBAD MgO and homoepitaxial layers is done during deposition using reflection high-energy electron diffraction (RHEED) to confirm the existence of in-plane texture [19][37].

IBAD was first developed for use by the high T_c superconducting community [1]. Its potential for extending the reach of membrane-based thin film characterization measurements was only recently tapped [8]. IBAD + homoepitaxial MgO has been used for measuring the heat capacity of epitaxial FeRh thin films, demonstrating its effectiveness as an intermediate layer for growing epitaxial thin films on amorphous membranes. In this previous work, 10 nm of IBAD MgO and 15 nm of homoepitaxial MgO was grown onto the 200 nm amorphous SiN membrane of a microcalorimeter. FeRh was then grown epitaxially on top of the homoepitaxial MgO [8]. IBAD MgO was also grown onto a 30 nm amorphous SiN membrane of a nanocalorimeter used for taking thermal measurements of small thin film samples. The IBAD MgO caused the membrane to wrinkle (Figure 1.3), indicating significant strain. The wrinkly membrane presents a clear problem for growing an epitaxial thin film onto this membrane. IBAD MgO appears to have reached a limit in usefulness for growing epitaxial samples onto amorphous membranes.

1.4 Stress, strain, and structural distortion in IBAD MgO

The wrinkly membrane is a result of in-plane stress causing strain and structural distortion in the IBAD MgO film. In addition to this image (Figure 1.3) as evidence for the IBAD MgO's strain, high intensity XRD measurements of the IBAD MgO film confirm the existence of in-plane strain [8]. Bulk MgO is cubic, with a lattice constant of 4.212 Angstroms. IBAD MgO is orthorhombic. The out-of-plane lattice constant in IBAD MgO is the same as the bulk. However, IBAD MgO exhibits in-plane lattice constants of 4.228 Angstroms along the [020] and 4.202 along the [200]. The ion beam is pointed along the [202] during growth. This means that the lattice parameter parallel to the projection of the ion beam is smaller than the bulk, and the lattice parameter perpendicular to the projection of the ion beam is larger than the bulk [8].

Film stress can come from a variety of sources including a mismatch in lattice constant between the film and the substrate, growth mechanism such as coalescence of islands during growth, bombardment due to high energy growth techniques such as sputtering or use of an ion beam, and differential thermal contraction between film and substrate when growth and characterization take place at different temperatures. IBAD MgO films have no epitaxial relationship to the amorphous substrate, and they are grown at room temperature. There-

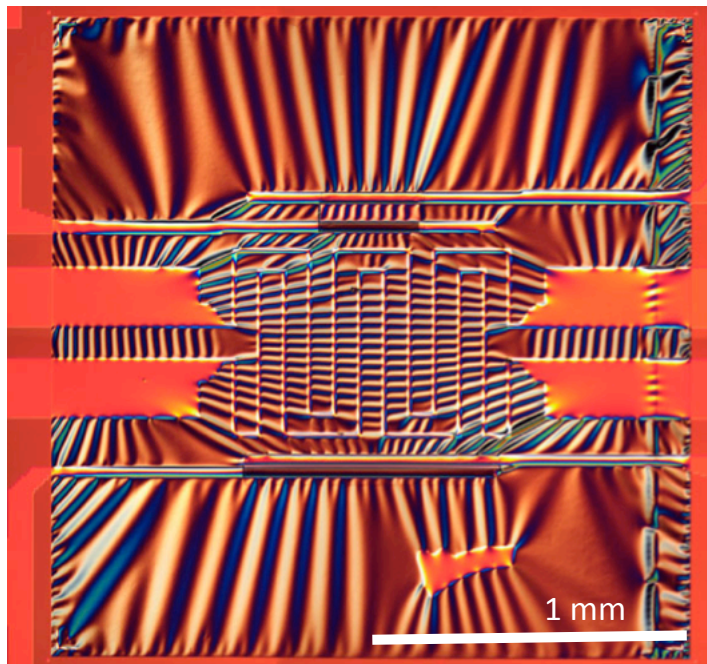

Figure 1.3: Phase-contrast optical microscope image of 30 nm amorphous SiN membrane with IBAD MgO deposited. The flat red areas, both narrow and wide, are thick Pt layers (with IBAD MgO) and are flat; the colorful patterns between are areas of membrane with IBAD MgO on them, showing significant tensile strain. The membrane is the platform of a nanocalorimetry device. This is a smaller version of the device shown in Figure 1.1, used for measuring heat capacity of small thin film samples. The wrinkles in the membrane are caused by the strain in the IBAD MgO film. This demonstrates the problem that IBAD MgO's in-plane strain presents for its use for growing epitaxial thin films on amorphous membranes. Image taken by Dr. Dave W. Cooke: Strain Fields of a Buckled Silicon Nitride Membrane APS March Meeting 2010, 3/17/10, Portland, OR.[10]

fore, a mismatch in lattice constant between film and substrate as well as differential thermal contraction are not the sources of stress causing the observed strain in IBAD MgO films. It is likely that the energy of the bombardment of the film by the ion beam causes film stress, and it is possible that the IBAD MgO growth mechanism, also caused by the ion beam bombardment, leads to film stress as well. However, a solid model for the growth mechanism is still in development, so the origin of the observed strain and structural distortion is not well understood, and little has been done to control or relax it. Further characterizing and tuning the stress would deepen our understanding of IBAD MgO films, increase the stability of IBAD films, as well as expand their use to supporting smaller samples on thinner membranes. Furthermore, being able to adjust the crystal structure of IBAD MgO from orthorhombic to cubic also expands the types of films that can be grown epitaxially on the

IBAD MgO.

1.5 Growth temperature and annealing to control stress and surface roughness

There are several parameters of the IBAD MgO film that may affect film stress including film thickness, growth temperature, and post-growth annealing. Previous work has shown that as the thickness of the IBAD MgO layer increases, the [020] in-plane lattice parameter perpendicular to the projection of the ion beam decreases and reaches the bulk value just below 5 nm film thickness, showing a relaxation of strain. The same work showed no change in the [200] in-plan lattice parameter parallel to the projection of the ion beam as the thickness of the IBAD MgO layer increased up to 5 nm, showing no change in strain [20].

No known work has been done to explore the effect of growth temperature and/or growth rate on the stress and strain of IBAD MgO films. While the work in this dissertation does explore the effect of growth temperature on IBAD MgO film stress, this work focuses particularly on the effect of annealing on IBAD MgO film stress. Post growth annealing is easy to control and proves to be a valuable tool for controlling both film stress as well as surface roughness.

RHEED measurements have shown that annealing IBAD MgO (without a homoepitaxial layer) improves its surface quality [30]. Annealing the IBAD MgO film also improved the quality of a LaMnO₃ (LMO) film grown directly on top of it to be comparable to an LMO film grown on top of IBAD MgO with a 20 nm homoepitaxial MgO layer. Previous work [30] determined that it was unclear whether the annealing simply improves the cleanliness of the surface or if it induces atomic mobility and affects the IBAD MgO film's structure. The work done in this dissertation determines that annealing does indeed affect the structure of the IBAD MgO itself.

These observations of the effects of annealing on IBAD MgO film quality suggest that annealing may relax the stress in IBAD MgO films. This dissertation work investigates the effect that annealing has on the IBAD MgO film stress and surface roughness. Understanding the way the film stress and surface roughness respond to annealing can give us a deeper insight into the stability and behavior of IBAD MgO films, as well as their growth mechanism. This deeper understanding will also help expand the uses and applications of IBAD MgO films and perhaps enable development of new types of IBAD films.

In this dissertation work, IBAD MgO film growth was done similarly to previous work. Films are grown onto amorphous silicon nitride or thermal silicon oxide by electron beam (e-beam) deposition in an ultra high vacuum (UHV) chamber. Ar⁺ ions are produced from a 750-volt DC Kaufmann ion source aimed at the substrate at a 45° angle. Film growth and texture of IBAD MgO, homoepitaxial MgO, and epitaxial films of Ag are monitored in-situ using RHEED. A full description of the growth is detailed in Chapter 2 of this dissertation.

The most significant difference between IBAD MgO film growth in previous work and

IBAD MgO film growth in this work is the ion to atom ratio (IAR). This is the ratio of the rate at which Ar^+ ions arrive at the substrate to the rate at which Mg and O atoms (i.e. MgO molecules) arrive at the substrate. Calculation of the IAR is detailed in Section 2.3. In this dissertation work, a substantially higher IAR is used than in previous work.

Film stress and surface roughness is measured for samples of both IBAD MgO and IBAD + homoepitaxial MgO. Film stress is calculated from wafer curvature measurements using laser interferometry. Wafer curvature is measured before and after film growth as well as after sequential annealing steps. Similarly, film surface roughness is calculated after the same annealing steps in order to determine any effects the annealing may have on roughness. Roughness is calculated from atomic force microscopy (AFM) measurements of IBAD MgO films alone as well as homoepitaxial MgO films of varying thicknesses grown on top of IBAD MgO. The film's quality as a substrate for epitaxy is also evaluated by growing films on top of the IBAD MgO and characterizing their structure using XRD. This is necessary due to the low z value of MgO, making the thin IBAD MgO and homoepitaxial MgO films (less than 15 nm in thickness) undetectable using X-ray diffractometry. Stress and roughness measurements are detailed and discussed in Chapter 4. XRD characterization of films grown on top of IBAD MgO and IBAD + homoepitaxial MgO are discussed in Chapter 3.

This dissertation work finds that annealing decreases both stress and roughness in IBAD MgO films, both with and without a homoepitaxial layer. Additionally, this study finds that an increase in growth temperature of the homoepitaxial layer also decreases film stress. Lastly, this work determines that using a high IAR during IBAD MgO film growth along with post-growth annealing may remove the need for the homoepitaxial layer when using IBAD MgO as an intermediate surface for growing epitaxial films on an amorphous platform.

Chapter 2

Growth and in-situ characterization of IBAD MgO

2.1 Basics of MgO growth

The MgO was grown in a Thermionics electron-beam (e-beam) evaporator. The e-beam chamber has a base pressure of 1×10^{-10} Torr. In e-beam evaporation, a beam of electrons is produced by a charged filament to which a potential difference of 8 kV is applied. A magnetic field aims the electron beam at a source of MgO pellets. The MgO pellets are purchased from Kurt Lesker in bottles of 50 mg of 3-6 mm pieces of fused MgO, 99.95% pure with a Ca content less than 750 ppm. The beam heats the MgO until it sublimates, producing an MgO vapor that deposits onto the substrate positioned above the source. A quartz crystal monitor (QCM) measures the MgO deposition rate during growth of both the IBAD layer and homoepitaxial layer. The QCM does not have line of sight to the ion gun.

The IBAD MgO layer was grown at room temperature. The homoepitaxial MgO layer was grown at 350 °C (unless otherwise stated) at a rate of 0.08 Angstroms/sec.

The ion gun was oriented 45° relative to the substrate's surface. This fixed orientation of the ion gun caused the argon ions to selectively bombard away MgO molecules that are not depositing in the desired orientation while the film is being grown. The argon ions create channels through the MgO film. The result is an MgO layer that is two-dimensionally textured and serves as a surface onto which homoepitaxial MgO can be grown without the use of the ion gun [20].

IBAD MgO grows (001) oriented on smooth, amorphous surfaces [20]. For this work, IBAD MgO was initially grown on low stress $\text{Si}_x\text{N}_{(1-x)}$ coated silicon substrates (1 cm²) and later on thermal oxide coated silicon wafers (2" diameter) to be used for laser interferometry measurements. Thermal oxide was eventually chosen over silicon nitride because it is cheaper and provides an equally smooth surface for IBAD MgO growth [31].

2.2 Ion gun electrical deposition

In order to induce biaxial texture in MgO while it's depositing onto the amorphous substrate, an Ar^+ ion beam is targeted at the substrate while MgO is depositing. Ar^+ ions are produced from a 3-cm 750-volt DC Kaufmann ion source aimed at the substrate at a 45° angle.

The ion source is operated at a pressure of 1.0×10^{-4} Torr. This pressure is established by flowing argon gas into the ion gun's discharge chamber (Figures 2.1 and 2.2) at a rate between 1.86 and 5.27 SCCM (standard cubic centimeters per minute). The flow rate is reported as a range because the flow rate required to establish a chamber pressure of 1.0×10^{-4} Torr varies over the course of several months of growth as small changes happen in the chamber's base pressure. There is an electrical discharge between the cathode and anode inside the discharge chamber, which creates positively charged argon ions. Above the discharge chamber are the screen grid and the accelerator grid. The accelerator grid is negatively biased, causing the Ar^+ cations to move from the discharge chamber, through the screen grid, toward the accelerator grid. Above the accelerator grid is a tungsten neutralizer filament that adds electrons to the ion beam. These electrons do not recombine with the Ar^+ cations. Instead, they offset the mutual repulsion between the Ar^+ cations.

A 750 volt power supply made by Ion Beam Scientific, model IBS 250 is used to operate the ion source. A standard preset recipe (parameters detailed below) is used to ramp up and sustain the ion beam from the ion gun. Operating parameters used by the power supply can be seen in Table 2.1. All pre-set values are reached automatically by the power supply except for the beam current. The recipe used has a beam current of 30 mA. After the beam is established, the beam current is manually turned down to 10 mA in order to lower the ion flux. Lowering the ion flux is necessary in order to establish the correct Ar ion to MgO atom ratio (IAR) for the IBAD MgO growth. IAR is detailed further in Section 2.3 of this dissertation.

In order to ramp up and turn on the ion beam from the ion source, the following steps are done automatically by the power supply. The discharge voltage, which is the voltage between the cathode and the anode, is increased. The discharge voltage is used to ionize the argon molecules to become Ar^+ cations. This voltage therefore needs to provide energy equal to or greater than 15.7596 eV, the first ionization energy of argon [12]. A discharge voltage of 40 volts is typically used for this. After a discharge voltage is established, a cathode current is set. The cathode current, which is the current running through the cathode filament, must be sufficient to generate a thermionic emission off of the tungsten cathode filament. Electrons emitted from the cathode are accelerated toward the anode. These accelerating electrons create a discharge current between the cathode and anode. The discharge current will ionize the argon gas to create Ar^+ ions. Next the neutralizer filament current is set. Similar to the cathode current, the neutralizer filament current must be high enough to produce an emission current of electrons coming off of the filament. A beam voltage of 750 volts is set. This is the voltage applied to the anode and is proportional to the kinetic energy of the Ar^+ cations. Next, an accelerator voltage is set. This is the voltage applied to the accelerator grid, which channels the Ar^+ ions out of the discharge chamber and through the

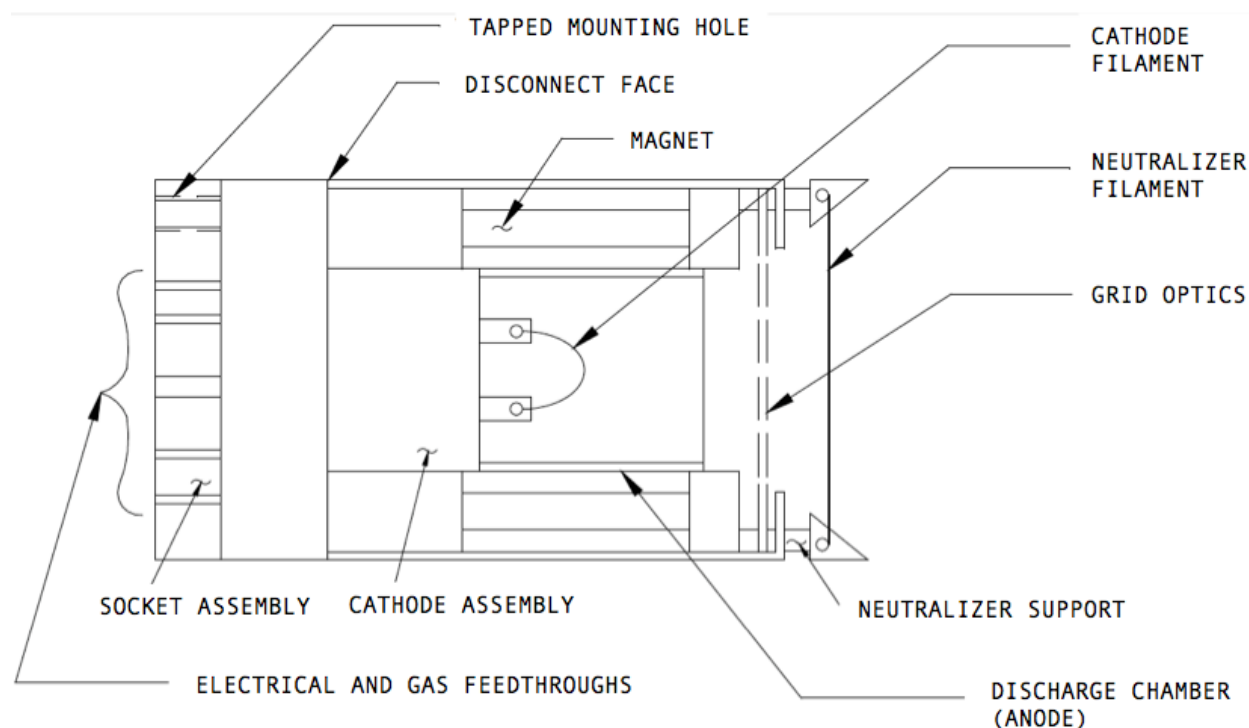

Figure 2.1: (Original figure modified from IBS 250 Power Supply Technical Manual. Veeco Instruments, Inc. 2002.) [36] Cross sectional drawing of 3 cm DC ion source. This drawing shows what each component looks like and its physical arrangement inside the ion gun.

screen grid.

After the above voltages and currents are established, the beam voltage and accelerator voltage adjust relative to each other to reach a 5:1 ratio of beam voltage to accelerator voltage. Next, the cathode current is adjusted to reach the desired beam current. In the recipe used, the beam current is set at 30 mA, but then manually reduced to 10 mA after a beam is established. The neutralizer filament current is then adjusted to reach an emission current that matches the beam current. Finally, the accelerator voltage is adjusted to equal 15-20% of the beam voltage.

2.3 Ion to atom ratio

The key parameter in the growth of IBAD MgO is the ion to atom ratio (IAR). This is the ratio of the rate at which Ar^+ ions arrive at the substrate to the rate at which Mg and O atoms (i.e. MgO molecules) arrive at the substrate. Too much Ar^+ relative to MgO will bombard away too much MgO, resulting in insufficient MgO to form a film. Too much MgO relative to Ar^+ will result in a polycrystalline non-textured film similar to one that would

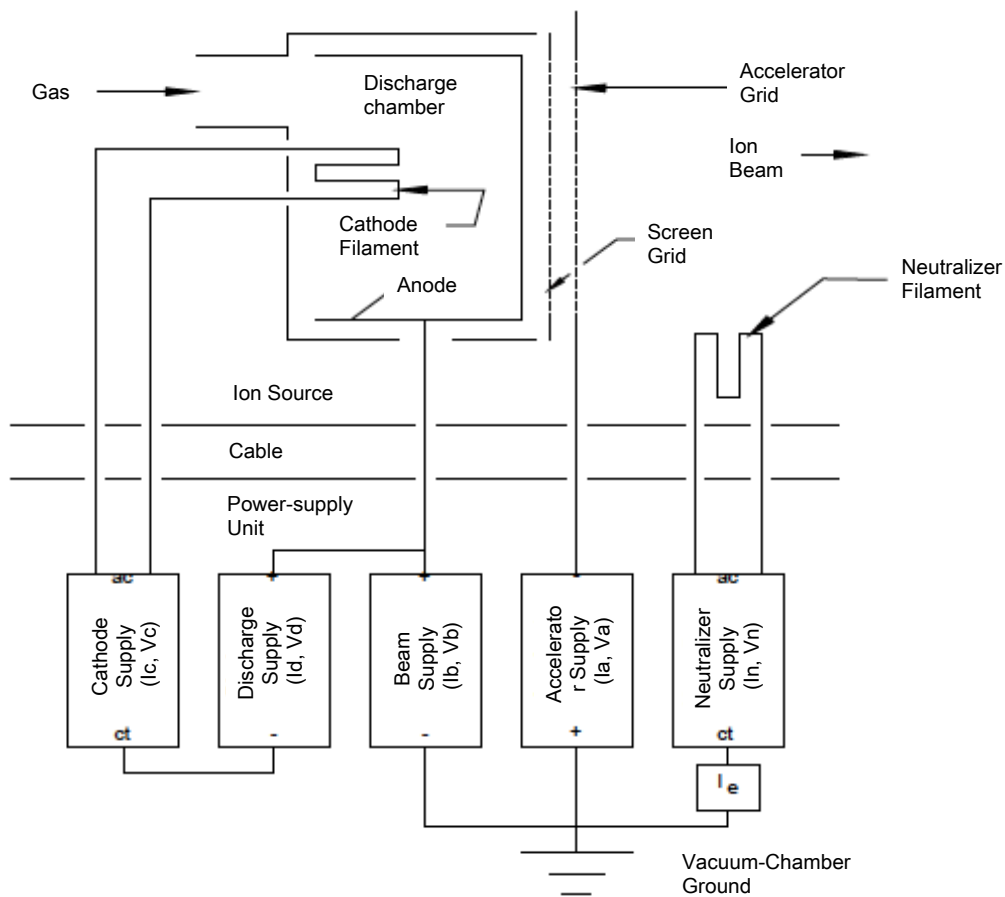

Figure 2.2: (Original figure modified from IBS 250 Power Supply Technical Manual. Veeco Instruments, Inc. 2002.) [36] Electrical schematic diagram of the 3 cm DC ion source and its connections to the 250 IBS power supply. This diagram shows the outputs and readings on the power supply, and how they correspond to the electrical function of the ion source.

Ion gun parameter	value
Ar gas flow (SCCM)	1.86-5.27
Chamber pressure (Torr)	$1 \cdot 10^{-4}$
Cathode filament current (amps)	6.2
Discharge current (amps)	0.57-1.59
Beam current (mA)	10
Beam voltage (volts)	750
Accelerator current (mA)	0-0.1
Accelerator voltage (volts)	112.5
Neut emis current (mA)	14.8-16.8
Ion flux ($\mu\text{A} \cdot \text{cm}^{-2}$)	190

Table 2.1: Parameters used for gas flow, chamber pressure, and voltage and current settings of ion gun components.

form without an ion beam there at all, since there is insufficient Ar^+ to affect the film's structure.

In order to determine the IAR being used in our IBAD MgO growth, the Ar^+ ion flux and the MgO deposition rate were measured. The ion flux was measured using a Faraday probe connected to a Keithley 2400 Sourcemeter with a bias of -90 volts applied to eliminate contributions from electrons and measure only Ar^+ flux. The Faraday probe was placed at the location of the sample during growth, and flux was measured with the ion gun and argon gas turned on, using all parameters used during an IBAD MgO growth. The MgO deposition was not turned on while measuring the ion flux. The ion flux increased slowly for approximately 20 minutes before stabilizing. For this reason, the ion gun was warmed up for at least 20 minutes before an IBAD MgO growth.

Parameters on the ion gun were adjusted to achieve the lowest stable ion flux. Because the lowest stable ion flux produced by the ion source used was relatively high, at $190 \mu\text{A} \cdot \text{cm}^{-2}$, the MgO rate was adjusted to fit this ion flux to achieve an IAR that produced a biaxially textured MgO film. Calculation of this MgO rate is detailed below.

The MgO deposition rate was measured using a QCM located above the MgO source, but not in the same location as the sample during film growth. Because the QCM is not located close to the sample plate, previous MgO rate checks were done to determine a tooling factor for the crystal monitor. Approximately 1000 Angstroms of MgO was grown onto a $\text{Si}_x\text{N}_{(1-x)}$ substrate, and the thickness was measured using an Alpha Step IQ Profilometer. The ratio of the thickness measured by the profilometer to the thickness measured by the QCM was used to determine the tooling factor for the QCM. This tooling factor was used for the remaining MgO growths.

The pressure increase from the argon gas flow used for the ion gun affects the MgO deposition rate. Therefore, the MgO rate used to calculate the IAR was measured with the argon gas flow on using pressure and flow parameters used during an IBAD MgO growth.

The ion gun is turned off during this MgO rate measurement. The MgO rate used was 1.12 Angstroms/sec.

In order to calculate the ion to atom ratio, the following three equations are used. To calculate the Ar⁺ ion flux:

$$F_{Ar} = \frac{F_{ion}}{A_p e} \quad (2.1)$$

where F_{Ar} is the Ar⁺ flux in ions sec⁻¹ cm⁻², F_{ion} is the charge flux as measured by the Faraday probe in amperes, A_p is the surface area of the Faraday probe, and e is the elementary charge of a proton in Coulombs. In this dissertation work, A_p is equal to 1 cm⁻², so F_{Ar} is equal to F_{ion} . To calculate the MgO flux:

$$F_{MgO} = \frac{rpN_A}{M} \quad (2.2)$$

F_{MgO} is the MgO flux in molecules sec⁻¹ cm⁻², r is the MgO deposition rate as measured by the QCM in cm/sec, p is the standard density of bulk MgO in g/cm³, M is the molecular weight of MgO, and N_A is Avogadro's constant. Using Equations 2.1 and 2.2, the IAR can be calculated:

$$IAR = \frac{F_{Ar}}{F_{MgO}} \quad (2.3)$$

The ion flux and MgO deposition rates measured in this work as described above result in a calculated IAR of 1.98. This IAR is not directly comparable to that used in previous work, since it is calculated differently. In the literature, the Ar⁺ flux is calculated the same way as in this work. However, the MgO rate is measured differently in the literature. In this work, the MgO rate is measured as the rate of deposition onto a crystal monitor that is close in proximity to the substrate but that is not in the line of sight of the ion gun. In literature describing previous work on IBAD MgO, the MgO rate is measured as the rate of MgO accumulation on the substrate during an IBAD MgO growth; this rate includes the effect of the ion gun bombardment on the MgO accumulation rate on the substrate [20]. In order to compare this work to previous IBAD MgO growths, I have calculated this alternative IAR value for my growths. The IBAD MgO rate used was approximately 0.15 Angstroms/sec. This is the rate of actual thickness accumulation on the substrate with the ion gun bombarding away a substantial fraction of the MgO. This rate is determined by growth time (the amount of time shutter is open to both ion flux and MgO flux simultaneously) and IBAD layer thickness measured after growth by X-ray reflectivity (XRR). The MgO rate measured by the QCM was much higher than this because the QCM is only in the path of the MgO and not in the path of the ion gun. While this method of calculating the IAR is different from the first one proposed in this work, it is necessary for comparability to previous work growing IBAD MgO. Using this rate of IBAD MgO accumulation of 0.15 Angstroms/sec, the

IAR is 14.77. This is over an order of magnitude higher than that used in the literature. An additional difference between the IBAD MgO films grown in this work and the ones grown in the literature is the absence of a polycrystalline layer of MgO preceding the appearance of biaxial texture as measured by the RHEED. In previous work, a polycrystalline RHEED pattern is observed before a biaxially textured pattern. These films also have a higher critical thickness (2 nm) at the onset of biaxial texture. In this work, the critical thickness is lower (1 nm), and biaxial texture is the first RHEED pattern observed. It is possible that the higher IAR affects the mechanism of texture formation in IBAD MgO and leads to a faster development of texture in the film.

2.4 RHEED monitoring

In order to determine if the ion flux, MgO rate, and IAR being used was indeed producing a biaxially textured film, the film was monitored in-situ during growth using reflection high-energy electron diffraction (RHEED).

RHEED is a surface-sensitive diffraction measurement that provides structural information about the surface of a film. RHEED uses a 25 kV electron source and a photoluminescent phosphor screen. The source produces a beam of electrons aimed at the sample at a glancing angle. The electrons diffract off of the sample surface at specific angles, depending on the crystal structure of the sample, and constructively interfere. The constructive interference of the diffracted electrons creates a pattern on the phosphor screen. When used during deposition, RHEED can show changes in the film's structure as it is growing. Read simply, a RHEED pattern can distinguish between an amorphous surface, a uniaxially textured surface, and a biaxially textured surface (Figures 2.3, 2.4, 2.6, and 2.5).

2.5 IBAD and homoepitaxial MgO growth

Careful observation of the RHEED pattern is crucial during the IBAD growth. When the growth begins, no RHEED pattern is observed, indicating the amorphous character of the $\text{Si}_x\text{N}_{(1-x)}$ or thermal oxide surface (Figure 2.3) onto which the IBAD MgO is grown. During the IBAD growth, the substrate is left at room temperature, though it does heat up by 10-15 °C during the 40-60 seconds of IBAD growth due to heat generated from the Ar^+ ions striking the substrate's surface.

After approximately 40 seconds of IBAD, faint spots begin to appear on the RHEED screen (Figure 2.5). The appearance of these spots indicates a presence of a biaxially textured IBAD MgO layer. After they are observed, the substrate shutter is abruptly closed. The ion gun and argon gas flow are turned off, the power on the MgO e-gun is reduced until a rate of 0.08 Angstroms/sec is measured by the QCM, and the substrate temperature is set to 350°C. After the substrate reaches 350°C, the substrate shutter is opened, and the QCM's thickness measurement is set to zero to measure the thickness of the homoepitaxial MgO layer as it

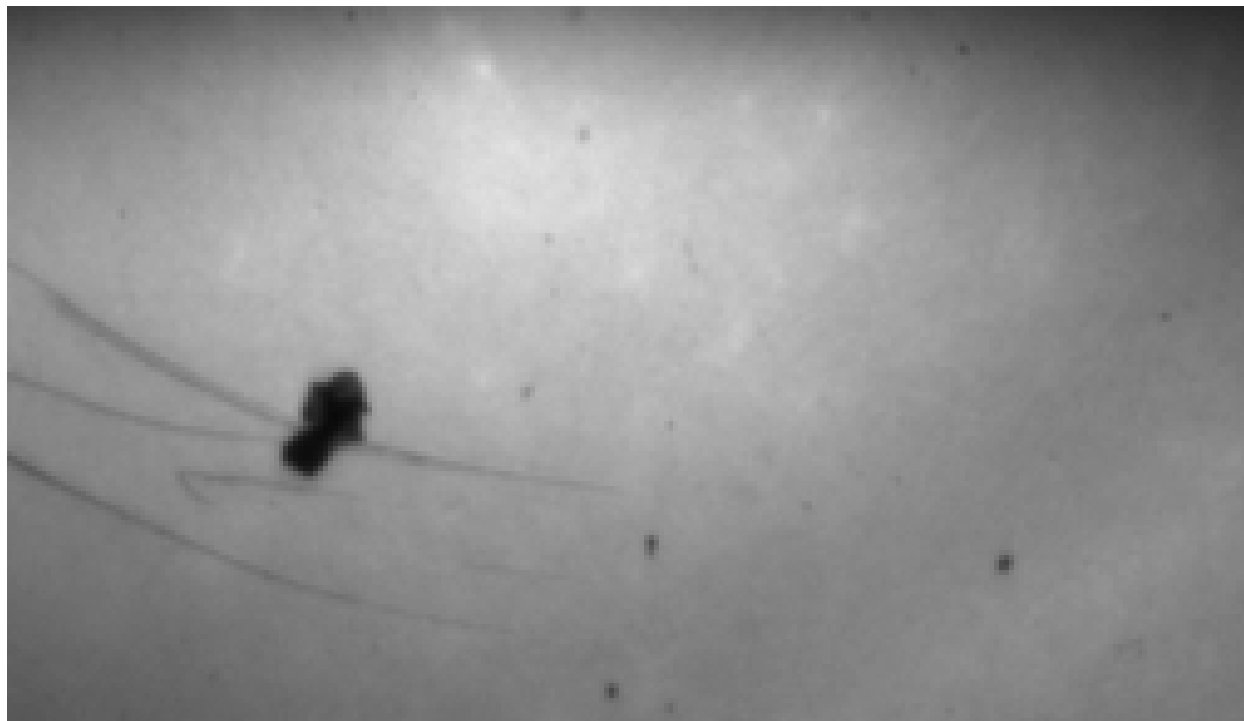

Figure 2.3: RHEED diffraction pattern for amorphous $\text{Si}_x\text{N}_{(1-x)}$ substrate.

accumulates. Now the homoepitaxial MgO layer is grown on top of the IBAD MgO layer. The intensity of the RHEED pattern increases as the thickness of the homoepitaxial layer increases (Figure 2.6). Apart from an increase in intensity, the pattern of spots does not change as the thickness of the homoepitaxial layer increases.

The standard thickness of the homoepitaxial MgO layer is 15 nm. However, this dissertation work explores thicknesses of both 5 nm and 15 nm for the homoepitaxial MgO layers. For application purposes, especially for thermal measurements, a thinner MgO layer contributes less to background heat capacity of the measurement platform.



Figure 2.4: RHEED diffraction pattern for polycrystalline MgO grown onto amorphous $\text{Si}_x\text{N}_{(1-x)}$.

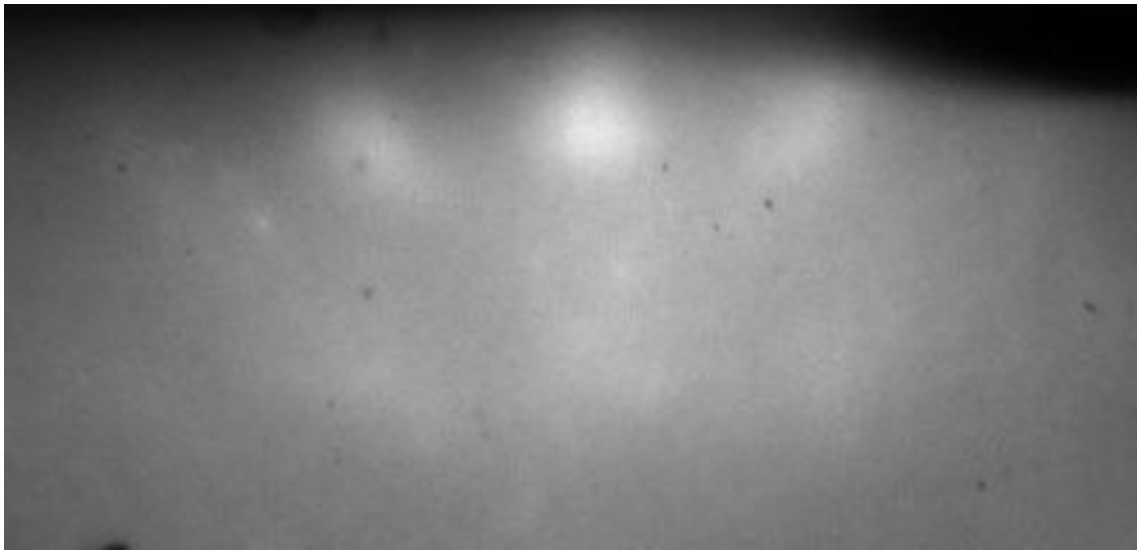

Figure 2.5: RHEED diffraction pattern for IBAD MgO only grown onto amorphous $\text{Si}_x\text{N}_{(1-x)}$.

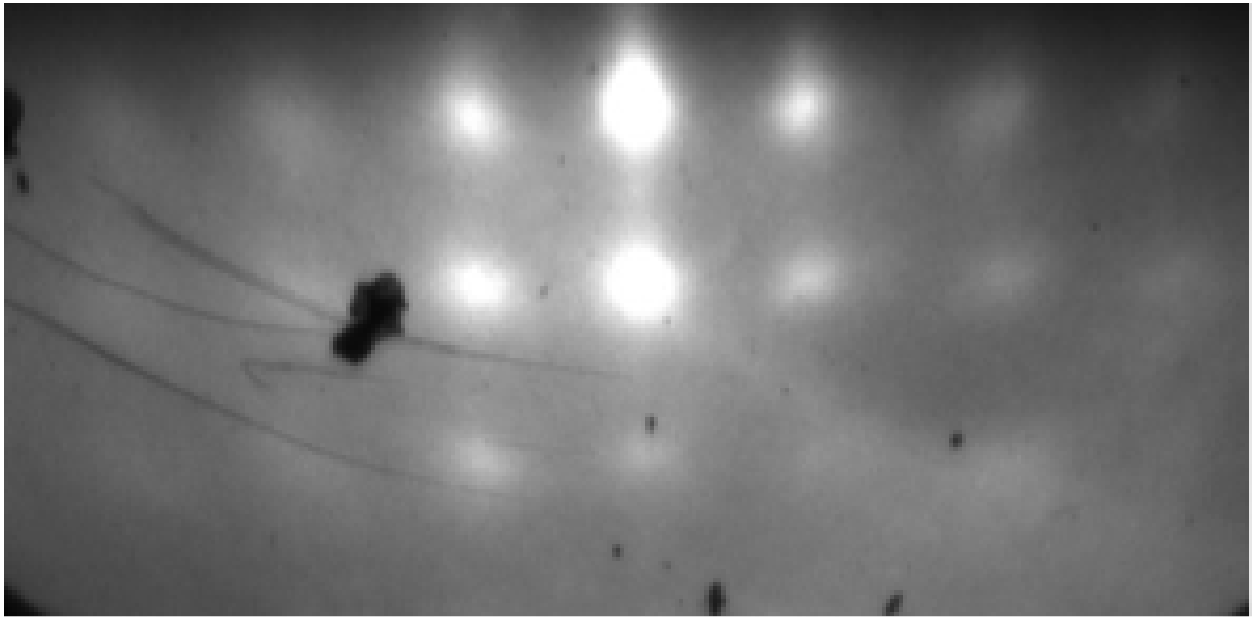

Figure 2.6: RHEED diffraction pattern for homoepitaxial MgO grown on top of biaxially textured IBAD MgO grown on amorphous $\text{Si}_x\text{N}_{(1-x)}$

Chapter 3

X-ray diffractometry of IBAD MgO

3.1 Introduction

IBAD and IBAD + homoepitaxial MgO has been developed to serve as an intermediate, biaxially textured layer between an amorphous surface and a biaxially textured film of interest. IBAD and IBAD + homoepitaxial MgO is intentionally very thin to minimize its interference with and contributions to background of properties being measured in the film grown on top of the IBAD and IBAD + homoepitaxial MgO. The IBAD MgO layer is approximately 1 nm in thickness, and the homoepitaxial MgO layer is 11 nm in thickness. Because the IBAD MgO is very thin and has a relatively low atomic number, high intensity synchrotron X-rays would be necessary to characterize the IBAD and/or homoepitaxial MgO layers directly. Previous work has been done using synchrotron X-rays to characterize some aspects of the IBAD MgO directly [20], but it did not explore the effects of annealing on the IBAD MgO film as this dissertation work does. Considering the function of the IBAD and IBAD + homoepitaxial MgO, the effectiveness of an IBAD or IBAD + homoepitaxial MgO film can alternatively be measured by the quality of a film grown on top of it. In order to characterize the effectiveness of the IBAD and IBAD + homoepitaxial MgO films, a silver (Ag) film approximately 500 Angstroms in thickness was grown on top. The thickness and atomic number of Ag allow it to be characterized by the laboratory X-ray diffractometer available to us. The quality of the Ag film was measured using X-ray diffraction (XRD).

Silver grows polycrystalline on an amorphous substrate and epitaxially with a (100) out-of-plane orientation on (100) MgO. By comparing the quality of a silver film grown on a commercial, single crystal, (100) MgO substrate to one grown on the IBAD MgO, we can measure the effectiveness of IBAD MgO as an intermediate layer. XRD measurements were done on a PANalytical X'Pert X-ray diffractometer with a Cu k-alpha X-ray source of wavelength 1.54178 Angstroms and a Ge 2220 monochromator.

3.2 Details of silver growth

The silver was grown in the same e-beam evaporator as the IBAD MgO. It was grown in-situ directly after the MgO growth. A QCM measured the Ag deposition rate during growth. The Ag layer was grown at room temperature at a rate of 0.02-0.06 Angstroms/sec. All Ag films in this work were 50 nm thick.

3.3 XRD of Ag on IBAD MgO

Ag films were grown onto two types of IBAD MgO films: 1 nm IBAD + 11 nm of homoepitaxial MgO and 1 nm IBAD MgO only with no homoepitaxial layer. 50 nm of Ag was grown on top of each of these IBAD MgO films, and omega-2-theta XRD scans were done on the Ag film. As described in Chapter 2, IBAD MgO is grown at room temperature, while the homoepitaxial MgO layer is grown at 350°C. This difference in growth temperature between the IBAD-only film and IBAD + homoepitaxial film could be responsible for differences in surface quality, and therefore measured differences in Ag film quality. Therefore, in order to remove growth temperature as a variable, the IBAD-only films were heated to 350°C for 30 minutes (approximately the time it takes to deposit the homoepitaxial layer) after depositing the IBAD MgO layer. The heater was then turned off, and the samples were cooled back down to room temperature before depositing the Ag film.

For comparison, Ag films were also grown on top of commercial single crystal (100) MgO substrates purchased from the MTI Corporation. These substrates were also heated to 350°C for 30 minutes and cooled to room temperature before Ag deposition.

The omega-2-theta XRD scans were done with a 2-theta range of 30-75 degrees. This range includes the Ag 111 and 200 Bragg reflections as well as the Si 400 reflection. The IBAD MgO films are grown on top of 1000 Angstroms of amorphous $\text{Si}_x\text{N}_{(1-x)}$ or thermal oxide of silicon. The $\text{Si}_x\text{N}_{(1-x)}$ and thermal oxide were both grown via chemical vapor deposition on top of (100) silicon wafers. Therefore, the prominent substrate peak comes from the Si 400 Bragg reflection. For Ag films grown on top of the single crystal MgO substrates, the 2-theta range was 35-48 degrees. This range includes the Ag 111 and 200 Bragg reflections as well as the MgO substrate's 200 reflection.

Figures 3.1, 3.2, and 3.3 show the XRD spectra of Ag grown on top of 1 nm of IBAD MgO, 1 nm IBAD + 11 nm homoepitaxial MgO, and, a single crystal MgO substrate, respectively. Figure 3.1 shows both Ag 200 and 111 Bragg reflections, indicating a substantial presence of grains with both (100) and (111) orientations out-of-plane and a lack of biaxial texture and epitaxy with the MgO. This tells us that IBAD MgO only without the homoepitaxial layer is not an effective substrate for growing silver epitaxially. Figures 3.2 and 3.3 show only Ag 200 Bragg reflections, indicating that the Ag is (100) out-of-plane, as it grows epitaxially on (100) MgO. The quality of these Ag films can be quantified using the full width at half maximum (FWHM) of the Ag peaks in the XRD spectra. FWHM values for each Ag peak in each XRD spectrum are listed in Table 3.1.

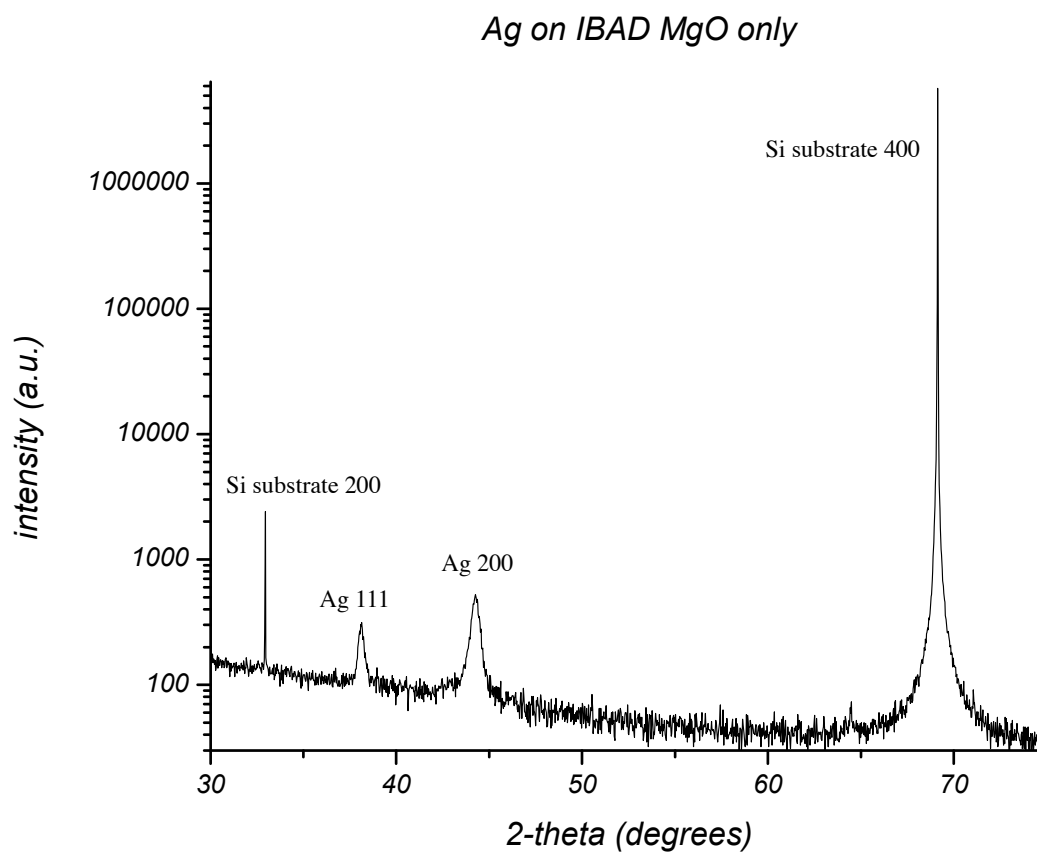

Figure 3.1: Omega-2-theta XRD scan of 50 nm Ag films grown on top of 1 nm IBAD MgO with no homoepitaxial layer.

Film	Ag on IBAD MgO only	Ag on IBAD + 11 nm homoepi MgO	Ag on MgO 100 single crystal substrate
Peak pos (deg)	44.265 +/- 0.025	44.286 +/- 0.025	44.310 +/- 0.025
FWHM (deg)	0.52 +/- 0.02	0.45 +/- 0.02	0.44 +/- 0.02

Table 3.1: FWHM of Ag (200) peaks

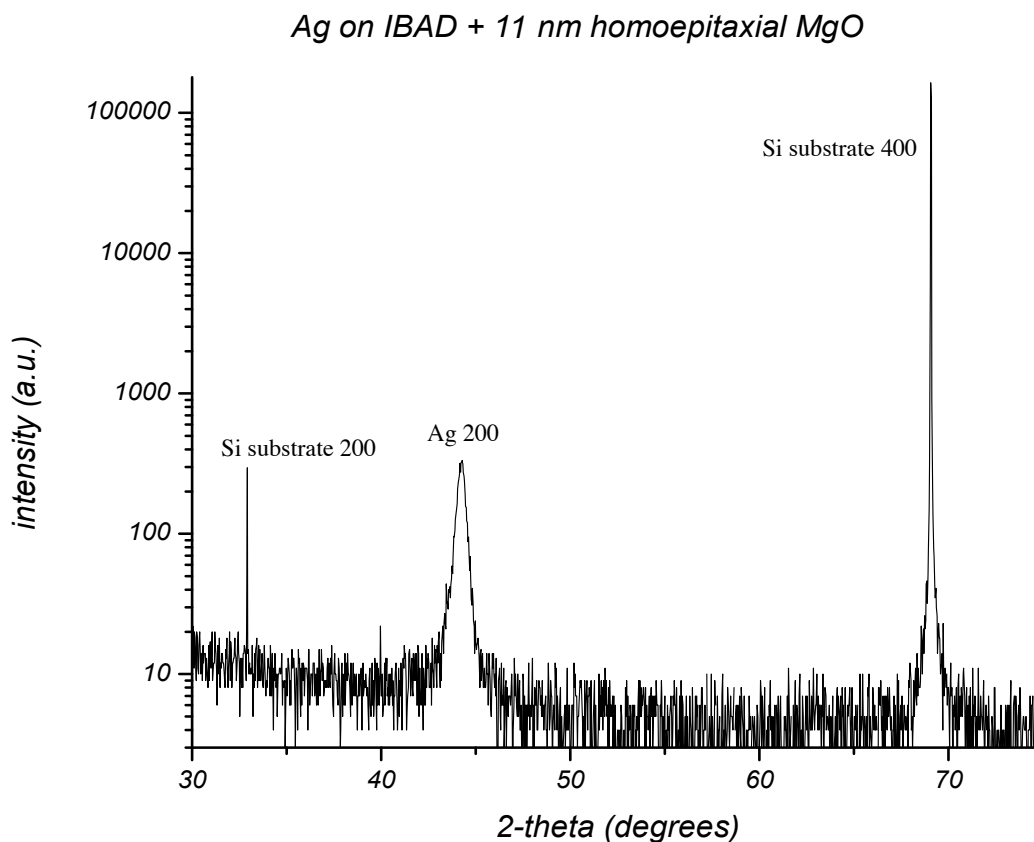

Figure 3.2: Omega-2-theta XRD scan of 50 nm Ag films grown on top of 1 nm IBAD + 11 nm homoepitaxial MgO.

The FWHM values of the Ag 200 Bragg reflections suggest that a single crystal MgO substrate allows for a Ag film of comparable quality to the IBAD + 11 nm homoepitaxial MgO. The Ag film on IBAD MgO only shows the largest value for FWHM, suggesting the lowest film quality, in agreement with its presence of a Ag 111 Bragg reflection.

The Ag films that showed only a Ag 200 Bragg reflection in the omega-2-theta scans are of higher quality than the one showing both Ag 200 and 111 reflections. In order to compare the two higher quality Ag films in more detail, 360° phi scans were done on the Ag 111 off-axis Bragg reflection. If the Ag film is biaxially textured, it will show four Bragg reflections in the phi scan, indicating 4-fold in-plane symmetry of the silver's cubic crystal structure.

Figures 3.4 and 3.5 show the results of the 360° phi scan measurements on the Ag film grown on IBAD + homoepitaxial MgO and a commercial MgO substrate, respectively. Both phi scans of the Ag 111 Bragg reflection show 4-fold in-plane symmetry of the Ag film,

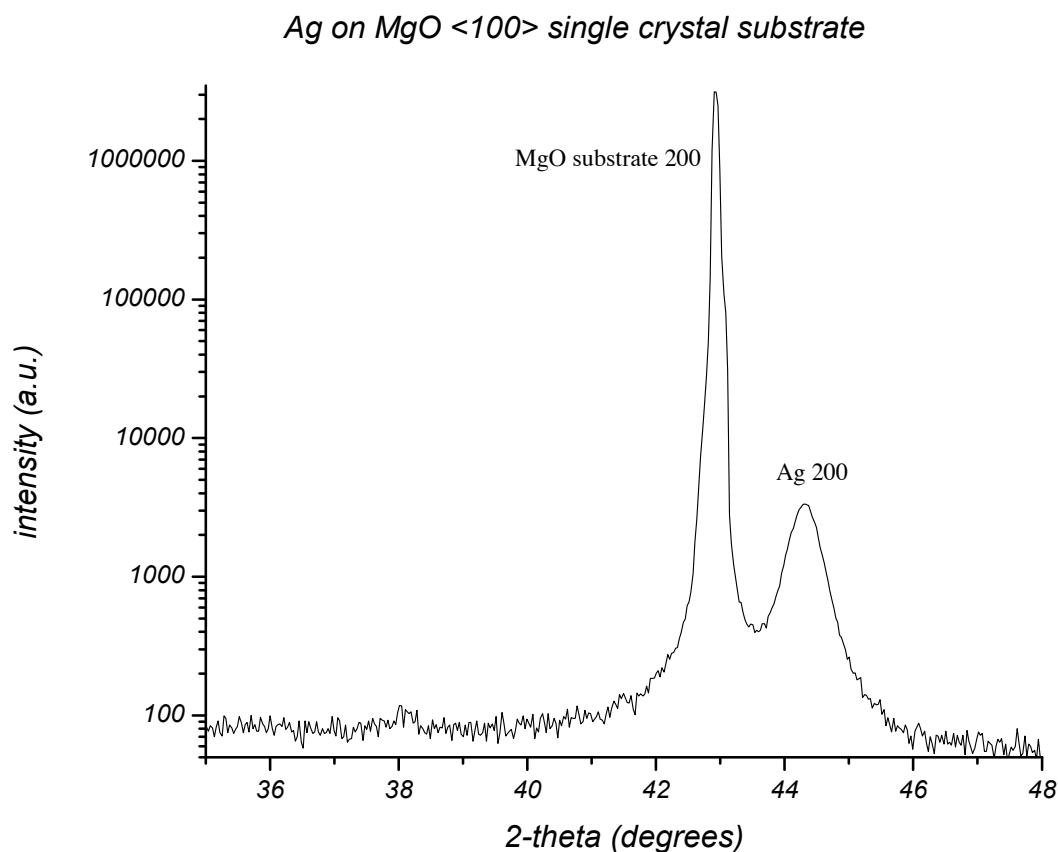

Figure 3.3: Omega-2-theta XRD scan of 50 nm Ag films grown on top of single crystal (100) MgO substrates.

indicating epitaxy of the Ag with the MgO surface.

Visually, it is clear that the Bragg reflections from the Ag film grown on the commercial MgO substrate are sharper than those from the Ag film grown on the IBAD + homoepitaxial MgO. The average FWHM of the reflections from the film grown on the commercial MgO substrate is 2.25 degrees. The average FWHM of the reflections from the film grown on the IBAD + homoepitaxial MgO is 7.63 degrees. The larger average peak width for the Ag film grown on IBAD + homoepitaxial MgO suggests higher mosaicity and therefore poorer epitaxy with the MgO than that of the Ag film grown on a commercial substrate. While the IBAD MgO method cannot produce Ag films of equal quality to those grown on a single crystal substrate, the clear 4-fold symmetry to the Ag film grown on the IBAD + homoepitaxial MgO demonstrates the effectiveness of the IBAD process for use as an intermediate layer on which to grow epitaxial films on an amorphous surface.

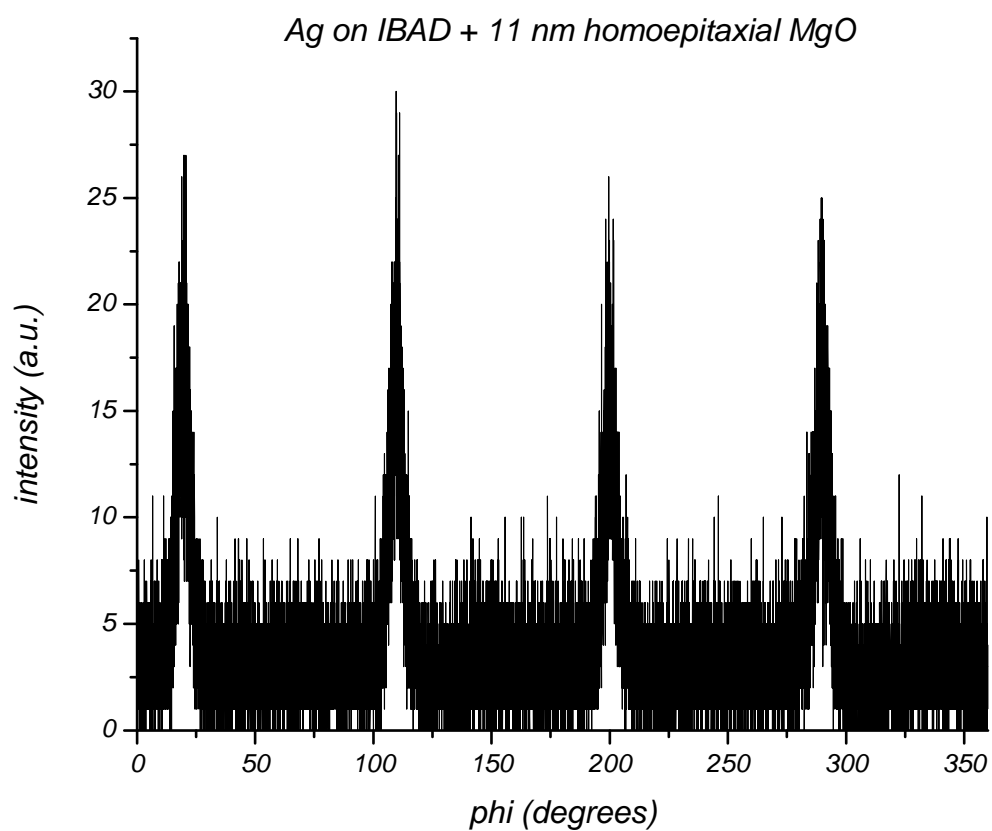

Figure 3.4: 360° phi XRD scan of the 111 Bragg reflection of 50 nm Ag films grown on top of IBAD MgO + 11 nm homoepitaxial MgO.

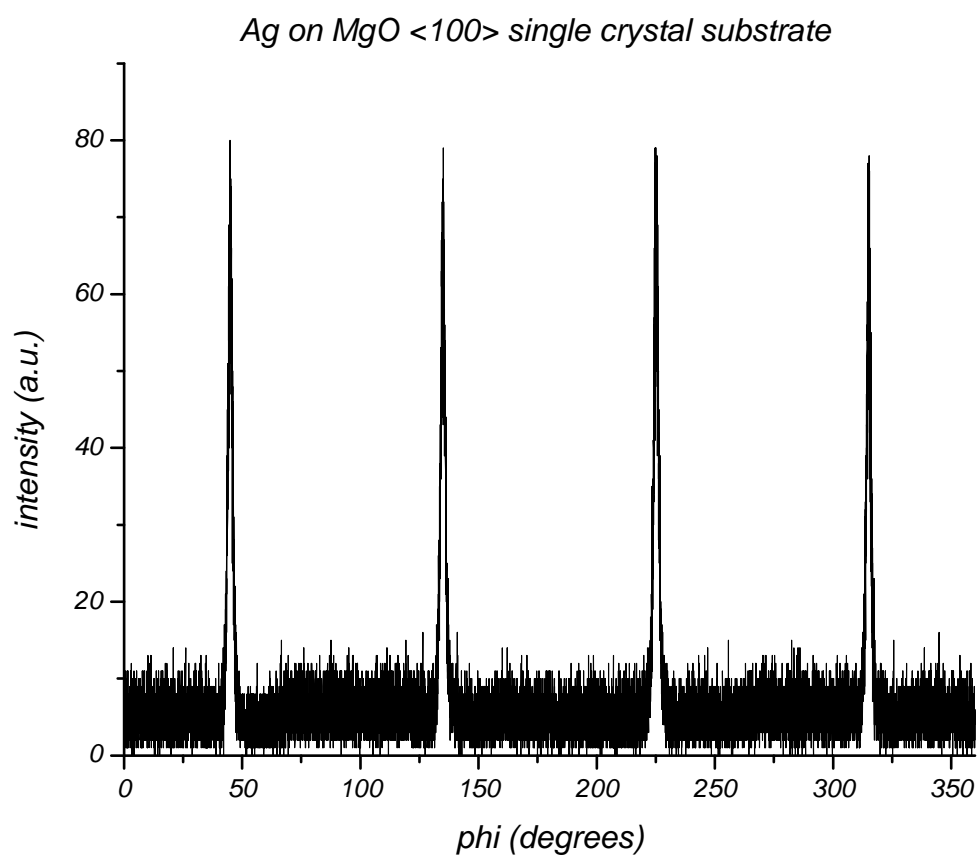

Figure 3.5: 360° phi XRD scan of the 111 Bragg reflection of 50 nm Ag films grown on top of commercial single crystal (100) MgO substrates.

Chapter 4

Stress and surface roughness in IBAD MgO

4.1 Introduction to stress measurements

Stress in the IBAD and IBAD + homoepitaxial MgO films has been evidenced by phase-contrast optical microscope images of IBAD MgO grown on 50 nm amorphous $\text{Si}_x\text{N}_{(1-x)}$ membranes (Figure 1.2) [10]. The wrinkles in the membrane are caused by the internal stress in the IBAD MgO film, visible when the membrane is viewed under a phase-contrast optical microscope. Stress describes the force applied to the film, while strain is the change in lattice constant of the film in response to this stress. Thin films can experience biaxial stress, in which the film may be stressed in both in-plane directions, x and y, but not in the out-of-plane direction, z. The amount of strain observed in response to biaxial stress is shown by the following three relationships:

$$\epsilon_x = \frac{1}{Y} (\sigma_x - \nu\sigma_y) \quad (4.1)$$

$$\epsilon_y = \frac{1}{Y} (\sigma_y - \nu\sigma_x) \quad (4.2)$$

$$\epsilon_z = \frac{-\nu}{Y} (\sigma_x + \sigma_y) \quad (4.3)$$

where ϵ_x , ϵ_y , and ϵ_z are film strain in the x, y, and z directions, respectively, σ_x , σ_y , and σ_z are film stress in the x, y, and z directions, respectively, Y is Young's Modulus of the material being stressed, and ν is the Poisson ratio of the material being stressed. The stress in IBAD MgO films has also been evidenced previously by observation of strain from synchrotron XRD measurements of in-plane lattice parameters in IBAD MgO. Results from previous work showed that while bulk MgO has a cubic unit cell, with $a = b = c = 4.212$ Angstroms, IBAD MgO has an orthorhombic unit cell in which $a = 4.228$ along the [020], $b = 4.202$ along

the [200], and $c = 4.212$ out-of-plane, which is equal to the bulk value [8]. The ion beam is directed along the [202], so a compression of the lattice parameter parallel to the projection of the ion beam is observed, as well as an expansion in the lattice parameter perpendicular to the ion beam's projection; the out-of-plane lattice parameter is unaffected by the ion beam. In this dissertation work, the film stress in the IBAD and IBAD + homoepitaxial MgO is further evidenced and quantified through measurements of wafer curvature using laser interferometry.

In addition to measuring the film stress in as-grown IBAD and IBAD + homoepitaxial MgO of varying film thicknesses, this work tests the hypothesis that post-growth annealing can decrease the stress in the film. In order to further understand as well as relax the stress in the IBAD and IBAD + homoepitaxial MgO films, film stress was measured after growth as well as at incremental post-growth annealing temperatures. The effect of changing growth temperature of the homoepitaxial MgO layer on film stress is also measured. Lastly the effect of annealing temperature on film surface roughness, another aspect of film quality, is measured using atomic force microscopy (AFM). The larger goal of improving IBAD and IBAD + homoepitaxial MgO film quality with post-growth annealing and growth temperature is evaluated.

4.2 Film stress measurements using the Flexus

Stress of the IBAD and IBAD + homoepitaxial MgO film was measured using a Tencor FLX-2320, also called a Flexus. The Flexus uses a laser interferometer to measure the radius of curvature of the wafer, and from that calculates the stress of the thin film grown on the wafer. The laser reflects off the surface of the wafer at several points in a straight line across the diameter of the wafer. These measurements are taken before the film is grown, and again after the film is grown. The difference in the radius of curvature before and after film growth can be used to calculate the film stress with the following equation [6]:

$$\sigma = \frac{E}{1 - \nu} * \frac{h^2}{6t} \left(\frac{1}{R_{film}} - \frac{1}{R_{nofilm}} \right) \quad (4.4)$$

where σ is film stress in Pa, $E(1 - \nu)^{-1}$ is the biaxial elastic modulus of the substrate, equal to 1.805×10^{11} Pa for the [100] silicon wafer used, h is the substrate thickness, approximately $300 \mu\text{m}$, t is the film thickness of the MgO, ranging from 1 to 16 nm, R_{film} is the radius of curvature of the wafer after film growth, and R_{nofilm} is the radius of curvature of the wafer before film growth.

The Flexus stress measurements rely on the film's being grown on a circular wafer. In order to measure stress of IBAD and IBAD + homoepitaxial MgO films, 2-inch silicon wafers coated in 1000 Angstroms of amorphous thermal oxide were used as substrates. Wafers were purchased from WRS Materials and had a thickness of 256-306 μm including thermal oxide

coating on both sides. IBAD and homoepitaxial MgO films were grown in the same e-beam deposition system and using the same technique described in Chapter 2 of this dissertation.

After initial measurements to determine film stress after growth, wafers were annealed for 30 minutes under vacuum in 100°C increments (500°C, 600°C, 700°C, and 800°C) and re-measured in the Flexus after each anneal. These measurements showed the change in film stress as a result of annealing. All measurements were taken at room temperature. Before growth of IBAD and homoepitaxial MgO films, all wafers were annealed under vacuum at 800°C for 30 minutes so that any changes in wafer bow after post-growth anneals can be attributed to change in MgO film stress rather than annealing-induced change in the thermal oxide film or the silicon wafer itself.

Based on previous synchrotron measurements showing an asymmetry in the in-plane lattice constants of IBAD MgO, it was expected that the IBAD and IBAD + homoepitaxial MgO film stress would be asymmetric. Therefore, the stress was measured in two directions: parallel and perpendicular to the projection of the ion beam during growth.

IBAD MgO films used in previous work [8] had 15 nm of homoepitaxial MgO grown on top of the IBAD layer. This homoepitaxial thickness was therefore used as the standard IBAD + homoepitaxial MgO thin film sample. However, a thinner homoepitaxial layer would be better for applications such as nanocalorimetry, in which the IBAD + homoepitaxial MgO layer contributes to the background heat capacity of the device and limits the magnitude of heat capacity that can be measured. Ideally, the MgO film should be as thin as possible while still functioning as an intermediate layer on which to grow epitaxial samples. Therefore, in addition to measuring a standard film of IBAD + 15 nm of homoepitaxial MgO, we also studied films with a 5 nm homoepitaxial layer, as well as films of IBAD MgO only, with no homoepitaxial layer. If the quality of these thinner samples can be improved with post-growth annealing, it could remove the need for a 15 nm homoepitaxial layer as described in Chapter 1 of this dissertation.

4.3 Results of film stress measurements

The IBAD and IBAD + homoepitaxial MgO films have a compressive film stress in the in-plane direction parallel to the projection of the ion beam, as shown by the as-grown data points in Figure 4.1. This is consistent with previous synchrotron XRD measurements of IBAD MgO showing a decrease in the in-plane lattice parameter parallel to the projection of the ion beam. The as-grown data points in Figure 4.2 show that the IBAD and IBAD + homoepitaxial MgO films also have a compressive film stress in the in-plane direction perpendicular to the projection of the ion beam. This is not consistent with previous synchrotron XRD measurements of the lattice parameters of IBAD MgO showing an increase in the in-plane lattice parameter perpendicular to the projection of the ion beam (i.e. tensile strain). It is important to note that while the Poisson ratio of the MgO film (0.187) [25] is positive, the observed compressive stress in both in-plane directions does not necessarily contradict the material's positive Poisson ratio. While both in-plane lattice constants are

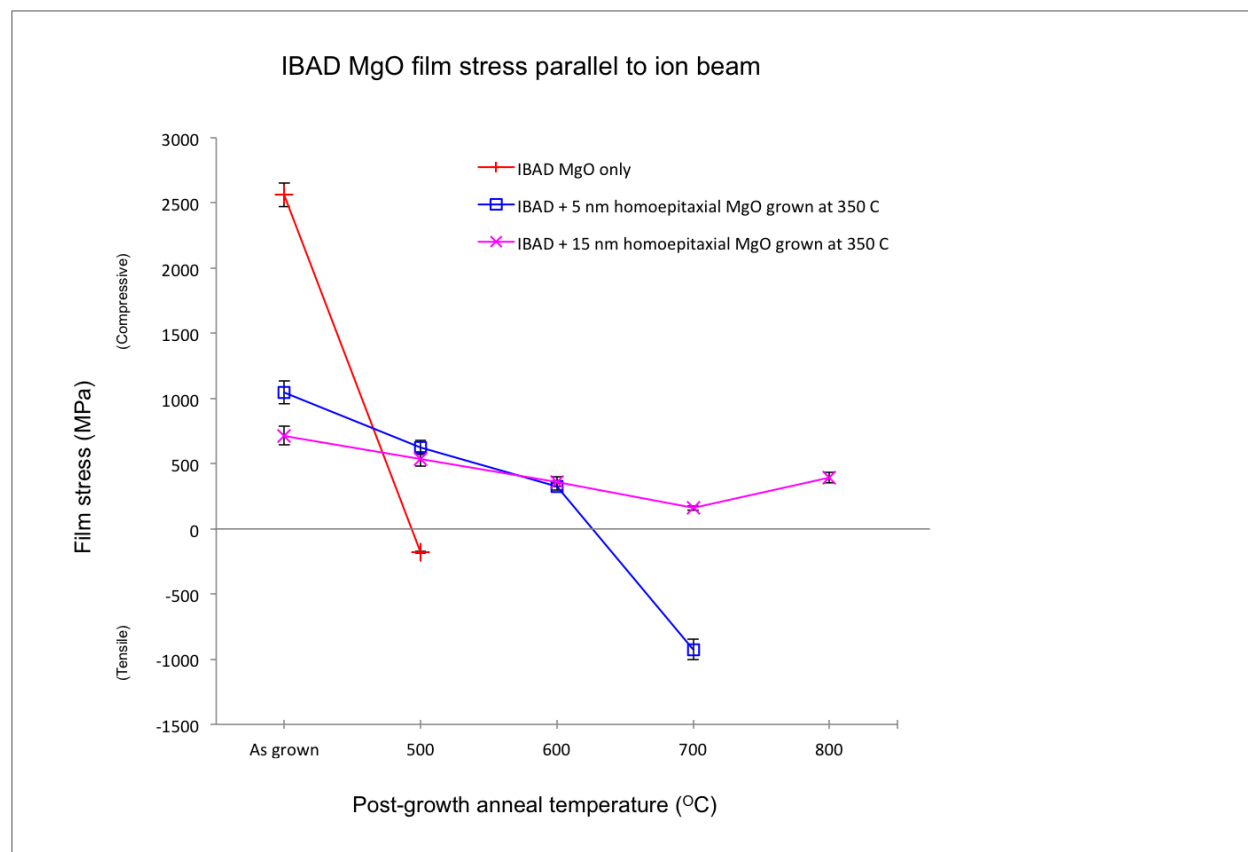

Figure 4.1: Film stress in as-grown state and after annealing, measured by radius of wafer curvature parallel to projection of ion beam during growth. Plot shows three different samples: IBAD MgO film only, IBAD + 5 nm homoepitaxial MgO grown at 350°C, and IBAD + 15 nm homoepitaxial MgO grown at 350°C. Error bars determined by standard error of mean value from 3 to 5 measurements are included in plots, though most are very small and inside marker symbols.

likely decreasing as a result of compressive stress in both in-plane directions, out-of-plane stress may be tensile, and out-of-plane lattice constant may be increasing in the MgO film, accounting for the positive Poisson ratio of the material.

Film stress can come from a variety of sources including a mismatch in lattice constant between the film and the substrate, growth mechanism such as coalescence of islands during growth, bombardment due to high energy growth techniques such as sputtering or use of an ion beam, and differential thermal expansion between film and substrate when the sample is exposed to high temperatures. IBAD MgO films have no epitaxial relationship to the amorphous substrate; therefore, a mismatch in lattice constant between film and substrate is not causing the observed stress in IBAD and IBAD + homoepitaxial MgO films.

It is likely that the energy of the bombardment of the film by the ion beam causes film

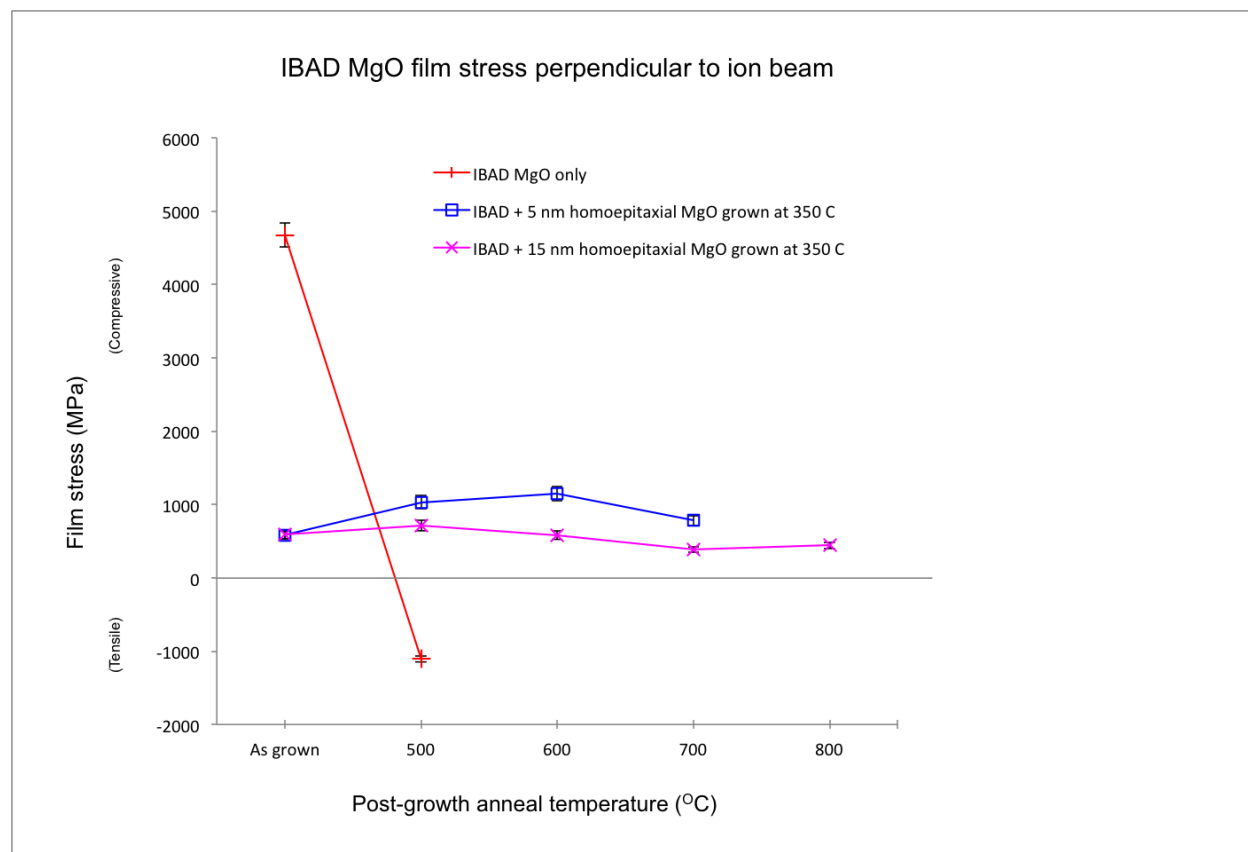

Figure 4.2: Film stress in as-grown state and after annealing, measured by radius of wafer curvature perpendicular to projection of ion beam during growth. Plot shows three different samples: IBAD MgO film only, IBAD + 5 nm homoepitaxial MgO grown at 350°C, and IBAD + 15 nm homoepitaxial MgO grown at 350°C. Error bars determined by standard error of mean value from 3 to 5 measurements are included in plots, though most are very small and inside marker symbols.

stress in the in-plane direction parallel to the projection of the ion beam, and it is possible that the IBAD MgO growth mechanism, also caused by the ion beam bombardment, leads to film stress in either or both in-plane directions. Lastly, differential thermal expansion between the MgO film and the substrate may also contribute to the stress.

One model to explain how the ion gun induces film stress parallel to the ion beam projection is the collision between the Ar^+ ions and the MgO lattice [38]. While most of the Ar^+ ions create channels in the film by bombarding away Mg and O atoms, some of the Ar^+ ions will also hit the Mg and O atoms in the lattice. This collision compresses the MgO lattice in the direction of the ion beam by squeezing excess Mg and O atoms per area in the plane of the film. Because the atoms are squeezed together, the response is interatomic repulsion between the Mg and O atoms. This repulsion, as a result of the compressive film

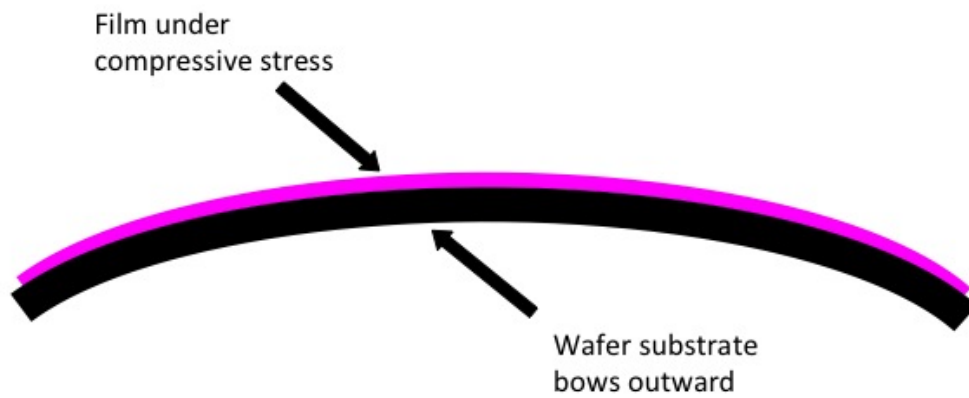

Figure 4.3: Cartoon showing wafer bow direction as a result of compressive film stress. Because the atoms in a film under compressive stress are squeezed too close together with an excess of atoms per unit area, interatomic Coulomb repulsions cause the film to bend the wafer outward.

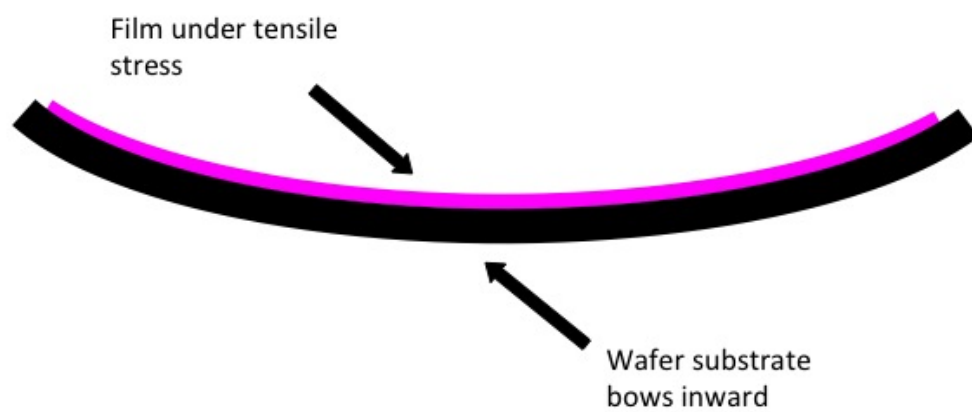

Figure 4.4: Cartoon showing wafer bow direction as a result of tensile film stress. Because the atoms in a film under tensile stress are spread too far apart from each other with a deficit of atoms per unit area, interatomic Coulomb attraction causes the film to bend the wafer inward.

stress, manifests in the stress measurements as the wafer bowing outward (Figure 4.3).

The as-grown data points in Figure 4.2 show that the IBAD and IBAD + homoepitaxial MgO films also have a compressive film stress in the in-plane direction *perpendicular* to the projection of the ion beam. This is not consistent with previous synchrotron XRD measurements of the lattice parameters of IBAD MgO showing an *increase* in the in-plane lattice parameter perpendicular to the projection of the ion beam (i.e. tensile strain). One possible reason for this difference could be the order of magnitude increase in IAR used in film growth in this work relative to previous work. The substantially higher IAR used in this work as well as the lack of observation of polycrystalline RHEED pattern before the appearance of a biaxially textured RHEED pattern point to the possibility of a different mechanism of texture formation when using substantially more ions during growth. This change in texture development could be connected to this observed change in stress.

Another possible reason for this difference could be differential thermal expansion and contraction. The thermal expansion coefficient for the silicon wafer is $2.6 \times 10^{-6} \text{ K}^{-1}$ [29], while that of MgO is $10.4 \times 10^{-6} \text{ K}^{-1}$ [24]. In order to determine the film stress caused by this difference in thermal expansion coefficient, the following equation can be used [22]:

$$\sigma_{th} = E_f \Delta T (\alpha_f - \alpha_w) \quad (4.5)$$

where σ_{th} is the maximum possible theoretical thermal stress applied to the MgO film, E_f is the elastic modulus of the MgO film (248.17 GPa) [25], ΔT is the temperature change that the MgO-coated wafer is exposed to, α_f is the thermal expansion coefficient of the MgO film, and α_w is the thermal expansion coefficient of the wafer.

Because the IBAD MgO layer is grown at the same temperature at which it is characterized for stress, one may not expect differential thermal expansion to result in any net change in film stress. According to Equation 4.5, any stress caused by differential thermal expansion during annealing should be lost when the film cools back down to room temperature before it is characterized. The σ_{th} for heating should be equal in magnitude and opposite in sign as the σ_{th} for cooling. However, this is only true if the annealing takes place quickly and does not provide sufficient time for the atoms in the film to rearrange to a lower stress state. Because films are annealed for 30 minutes, the atoms likely rearrange themselves to a lower stress state at the annealing temperature. Therefore, the atomic arrangement is different after reaching the peak annealing temperature and, upon cooling, may not shift back to the arrangement it had before heating, thereby creating a net stress caused by the cycle of heating and cooling. Even for the IBAD only MgO film that has not yet been annealed, the substrate temperature heats up by 10-15°C during the 40-60 seconds of IBAD growth due to heat generated from the Ar^+ ions striking the substrate's surface. Furthermore, the homoepitaxial MgO layers are grown at 350°C. For these films, there is a difference in growth temperature and characterization temperature. The differential thermal contraction between the homoepitaxial MgO film and the substrate may create film stress upon cooling from the growth temperature to the characterization temperature.

4.4 Results of annealing on film stress

It is clear that post-growth annealing decreases compressive film stress parallel to the ion beam for all samples measured. Annealing also decreases the compressive film stress perpendicular to the ion beam in the IBAD MgO only film, while doing very little to the perpendicular stress of the other two samples. This shows that annealing is effective at decreasing film stress in IBAD and IBAD + homoepitaxial MgO films. Parallel stress in the thickest film (IBAD + 15 nm homoepitaxial MgO) starts to flatten out as annealing temperature is increased, but never reaches zero or crosses into tensile stress. In the two thinner films (IBAD MgO only and IBAD + 5 nm homoepitaxial MgO), the parallel stress value decreases with increasing annealing temperature until the value crosses zero and becomes tensile.

Annealing induces mobility in the atoms in the films. The annealing gives the atoms energy to move into a state of lower energy and lower stress, stabilizing at low energy with a film stress close to zero for the higher film thickness. In the thinner films, annealing results in a crossover from compressive to tensile film stress. The change to tensile stress is likely due to stress relaxation followed by differential thermal contraction upon cooling.

There is an inverse correlation between film thickness and magnitude of film stress decrease brought about by annealing, as shown in Figure 4.1, in which the sharpness of the stress decrease after each annealing step is highest for the thinnest film of IBAD MgO only, and lowest for the thickest film of IBAD + 15 nm homoepitaxial MgO. Stress relaxation in thinner films occurs more readily most likely because less energy in the form of heat is required to nucleate and move the defects that relax the film stress.

The IBAD MgO only film (1 nm of IBAD MgO) is the most susceptible to stress relaxation by annealing. An annealing temperature of 500°C is sufficient to bring the compressive film stress slightly below zero and into the tensile range. In principle, a slightly lower annealing temperature may be used to put the film stress at zero. The next most substantial stress decrease is seen in the IBAD + 5 nm homoepitaxial MgO film. An annealing temperature between 600 and 700°C can bring this film's stress to zero. The IBAD + 15 nm homoepitaxial MgO film shows the least stress relaxation with annealing. This film stress did not reach zero with the annealing temperature range used (up to 800°C). As film thickness increases, the annealing temperature necessary to relax the film stress increases. This can be explained by comparing surface mobility to bulk mobility. Bulk atomic mobility requires more energy than surface atomic mobility due to the difference in number of nearest neighbors for surface atoms vs. bulk atoms. Because the IBAD-only film is only 1 nm (2-3 monolayers) thick, surface atoms account for nearly all of the film's volume. In the films with 5 and 15 nm of homoepitaxial MgO grown on top of the IBAD layer, surface atoms account for a smaller proportion of the film's volume. The thicker films have a greater proportion of atoms in the bulk rather than at the surface. These bulk atoms require more energy, and therefore a higher annealing temperature, to relax the stress.

It is also important to note that annealing brought the film stress of the two thinner films below the initial film stress of the standard 15 nm homoepitaxial film. This is promising

that post-growth annealing can be used to improve the quality of thinner IBAD and IBAD + homoepitaxial MgO films and possibly remove the need for a homoepitaxial layer.

4.5 Results of homoepitaxial layer growth temperature on film stress

The positive effect that annealing had to decrease film stress brought into question the effect of increasing the growth temperature of the homoepitaxial layer. All of these films had used 350°C as the homoepitaxial layer growth temperature. Could a higher temperature have a similar effect on film stress as post-growth annealing? If so, this could make the IBAD and IBAD + homoepitaxial MgO growth process more efficient.

To measure the effect of growth temperature on film stress, two IBAD + 15 nm homoepitaxial MgO films were grown onto wafers for stress measurements. These films were grown with the same parameters as previous films, except for the growth temperature of the homoepitaxial layer. One film's homoepitaxial MgO layer was grown at 425°C, and the other's was grown at 500°C. Like the previous films, the wafers were pre-annealed under vacuum for 30 minutes at 800°C. The film stress of these films were measured as-grown. These films were not exposed to further annealing steps.

It can be seen in Figures 4.5 and 4.6, which show the film stress measurements of IBAD MgO films with varying growth temperature for the homoepitaxial layer, that a homoepitaxial MgO growth temperature of 425°C had almost no effect on the film stress relative to a growth temperature of 350°C. However, a growth temperature of 500°C brings the compressive film stress below zero and into the tensile range. I suggest that a growth temperature between 425 and 500°C will produce a film stress of zero.

4.6 Effect of growth conditions and annealing on surface roughness of IBAD MgO films

While annealing has the beneficial effect of reducing the film stress in IBAD and IBAD + homoepitaxial MgO, there was concern that the increased mobility given to surface atoms with annealing could also increase surface roughness. This would be problematic for using the film as an intermediate layer on which to grown biaxially textured films. In order to monitor the change in surface roughness with annealing, AFM images were taken after film growth and repeated at the same annealing increments as the stress measurements: 500°C, 600°C, 700°C, and 800°C. AFM is a scanning probe microscopy technique with vertical resolution below 1 nm and lateral resolution between 1 and 5 nm [23].

Three different samples were measured using AFM: IBAD MgO only, IBAD + 5 nm homoepitaxial MgO grown at 350°C, and IBAD + 15 nm homoepitaxial MgO grown at 350°C. These samples were grown on 1 cm x 1 cm silicon substrates with 1000 Angstroms

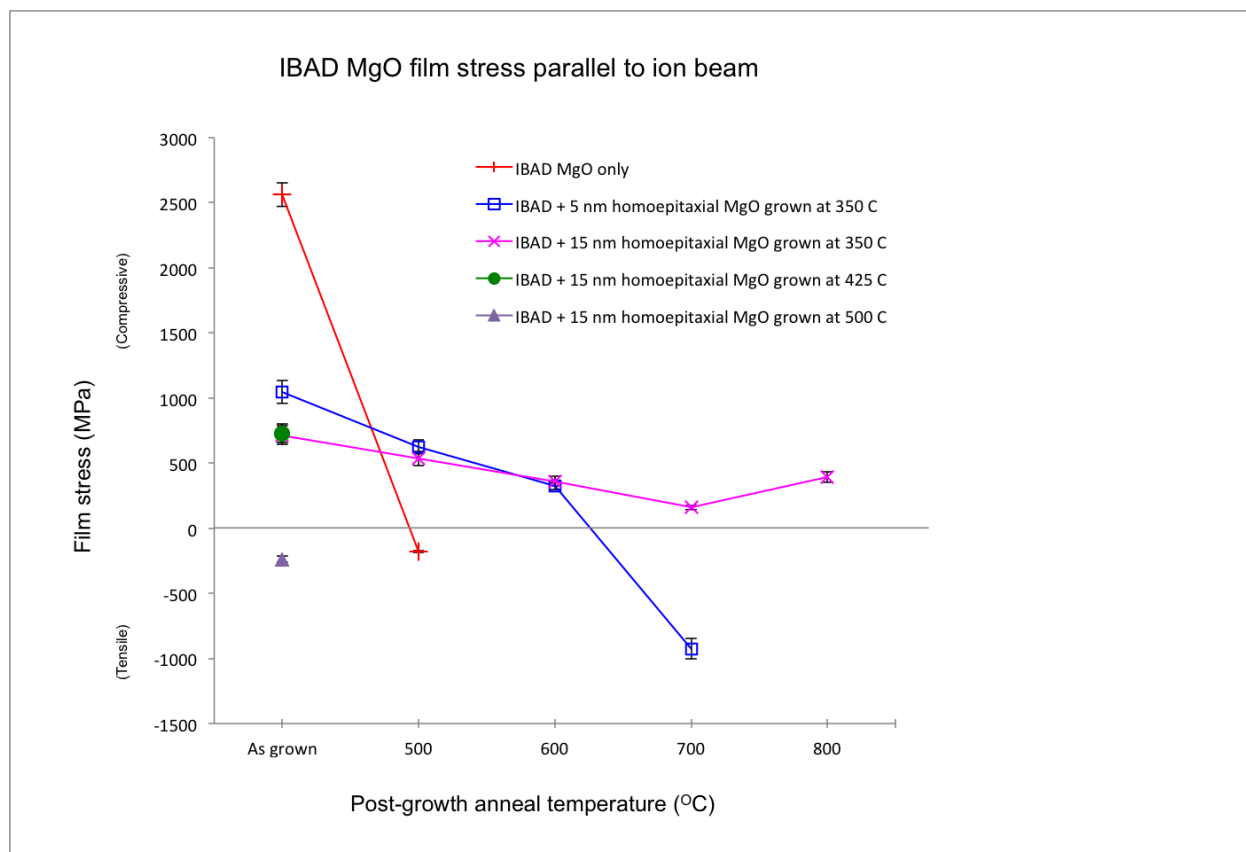

Figure 4.5: Film stress change with annealing and additional change of growth temperature, measured by radius of wafer curvature parallel to projection of ion beam during growth. Plot shows five different samples: IBAD MgO film only, IBAD + 5 nm homoepitaxial MgO grown at 350°C, IBAD + 15 nm homoepitaxial MgO grown at 350°C, IBAD + 15 nm homoepitaxial MgO grown at 425°C, and IBAD + 15 nm homoepitaxial MgO grown at 500°C. Films with homoepitaxial MgO grown at 425 and 500°C were not annealed after growth. Error bars determined by standard error of mean value from 3 to 5 measurements are included in plots, though most are very small and inside marker symbols.

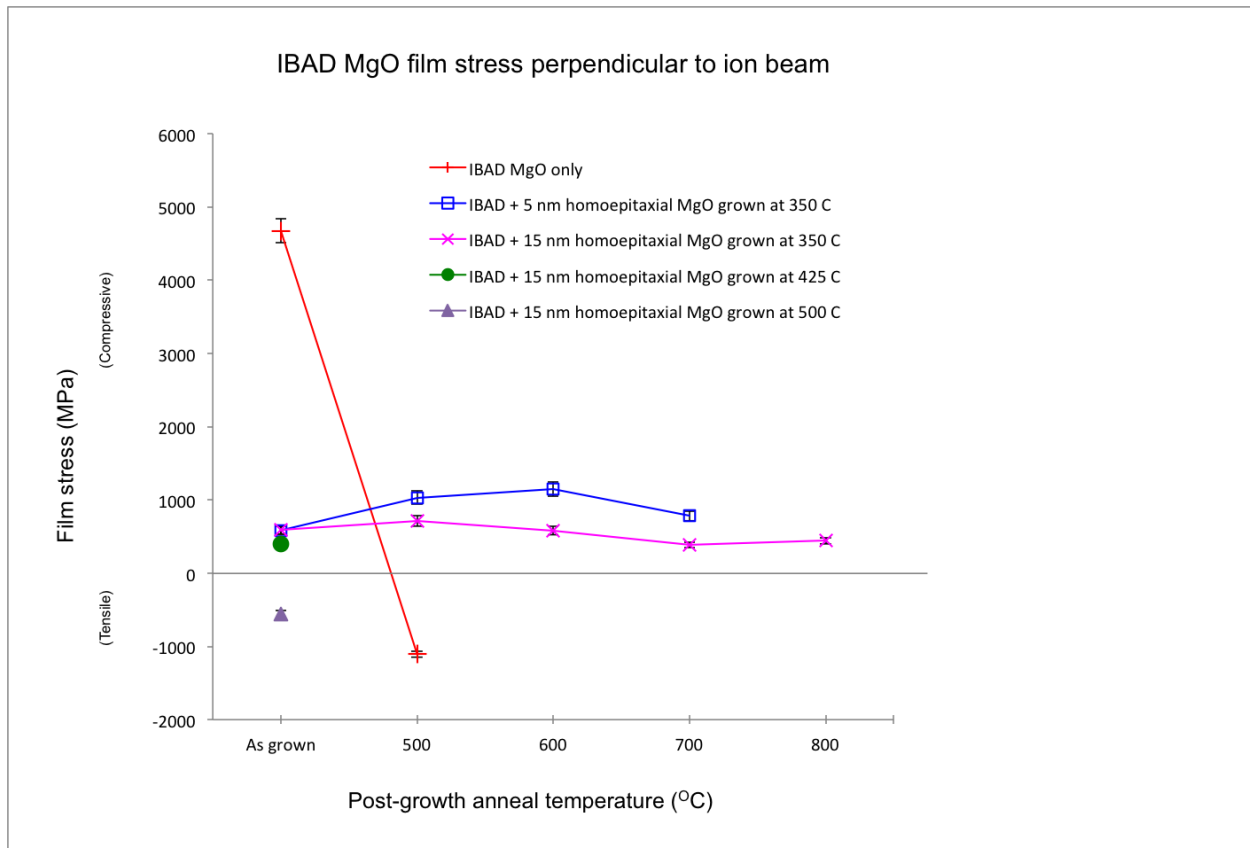

Figure 4.6: Film stress change with annealing and additional change of growth temperature, measured by radius of wafer curvature perpendicular to projection of ion beam during growth. Plot shows five different samples: IBAD MgO film only, IBAD + 5 nm homoepitaxial MgO grown at 350°C, IBAD + 15 nm homoepitaxial MgO grown at 350°C, IBAD + 15 nm homoepitaxial MgO grown at 425°C, and IBAD + 15 nm homoepitaxial MgO grown at 500°C. Films with homoepitaxial MgO grown at 425 and 500°C were not annealed after growth. Error bars determined by standard error of mean value from 3 to 5 measurements are included in plots, though most are very small and inside marker symbols.

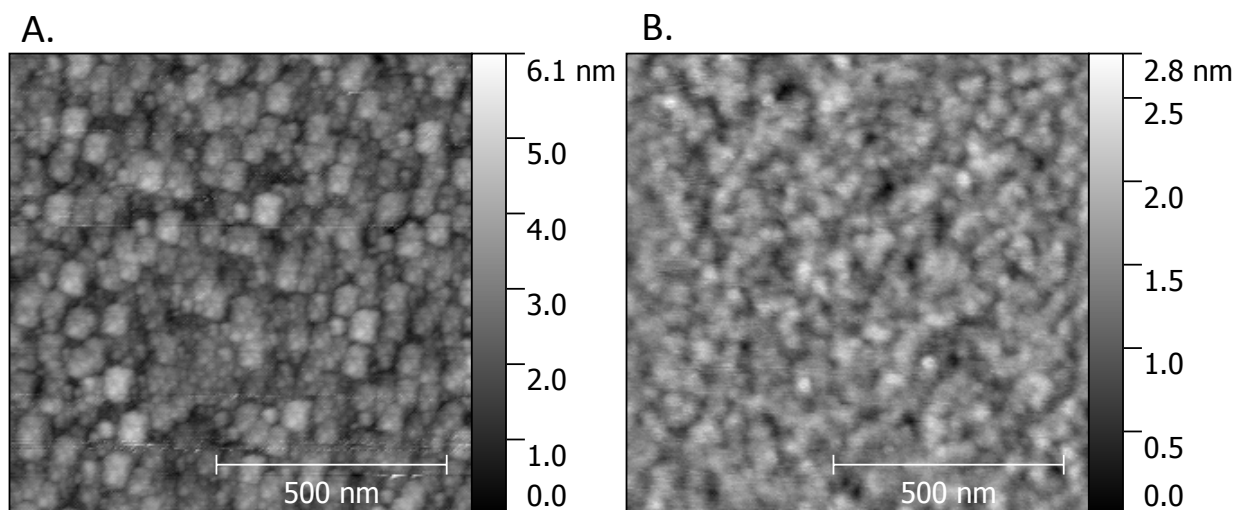

Figure 4.7: AFM image of IBAD only MgO film surface A. after growth, no annealing and B. after 500°C anneal for 30 minutes. It can be seen that the range of height of the vertical features decreases after the anneal. Visually, it can also be seen that the diameter of the grains decreases after the anneal. The rms roughness values were calculated from lateral profiles across the centers of each image.

of amorphous thermal oxide. Each sample was measured as-grown, and then after each 30-minute annealing step. All measurements were taken at room temperature. Unlike the wafers used for stress measurements, these substrates were not pre-annealed at 800°C because these measurements are surface sensitive only, and any change in the substrate caused by annealing should not effect the surface roughness measurements. AFM images showing the most dramatic changes in surface roughness - before and after the 500°C anneal - are shown in Figures 4.7, 4.8, and 4.9.

Images were analyzed for roughness. Roughness was determined across a linear profile of the image, and root mean square (rms) roughness was calculated. Figure 4.10 shows a plot of the roughness values calculated for each sample and at each annealing step.

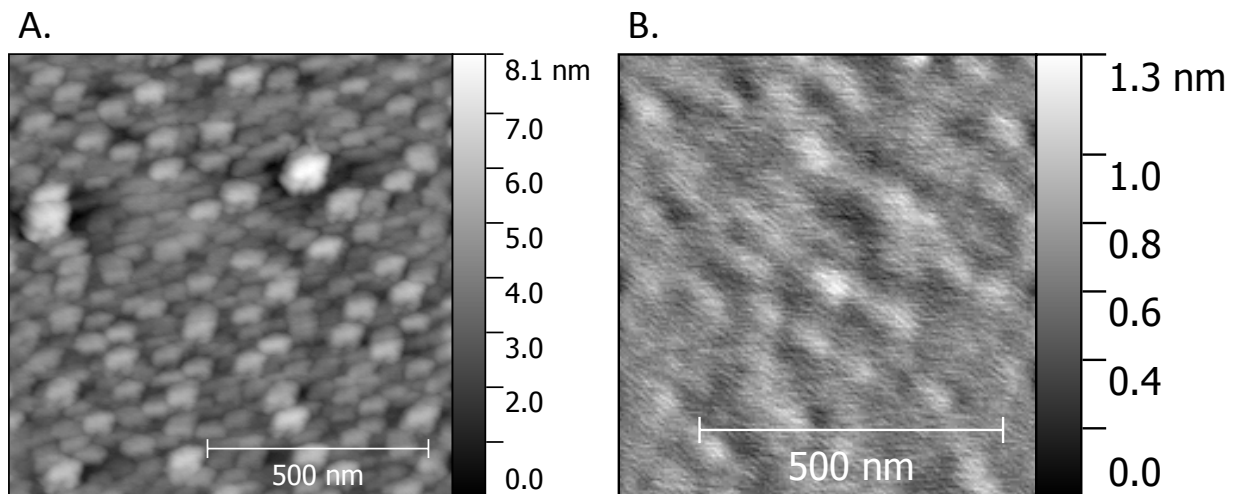

Figure 4.8: AFM image of IBAD + 5 nm homoepitaxial MgO film surface A. after growth, no annealing but homoepitaxial layer grown at 350°C and B. after 500°C anneal for 30 minutes. It can be seen that the range of height of the vertical features decreases after the anneal. The rms roughness values were calculated from lateral profiles across the centers of each image.

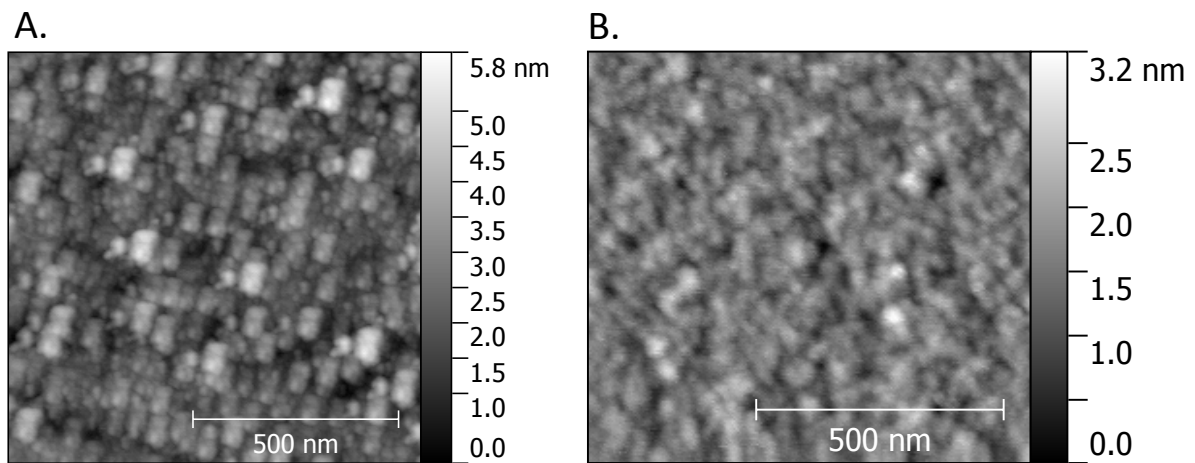

Figure 4.9: AFM image of IBAD + 15 nm homoepitaxial MgO film surface A. after growth, no annealing but homoepitaxial layer grown at 350°C and B. after 500°C anneal for 30 minutes. It can be seen that the range of height of the vertical features decreases after the anneal. The rms roughness values were calculated from lateral profiles across the centers of each image.

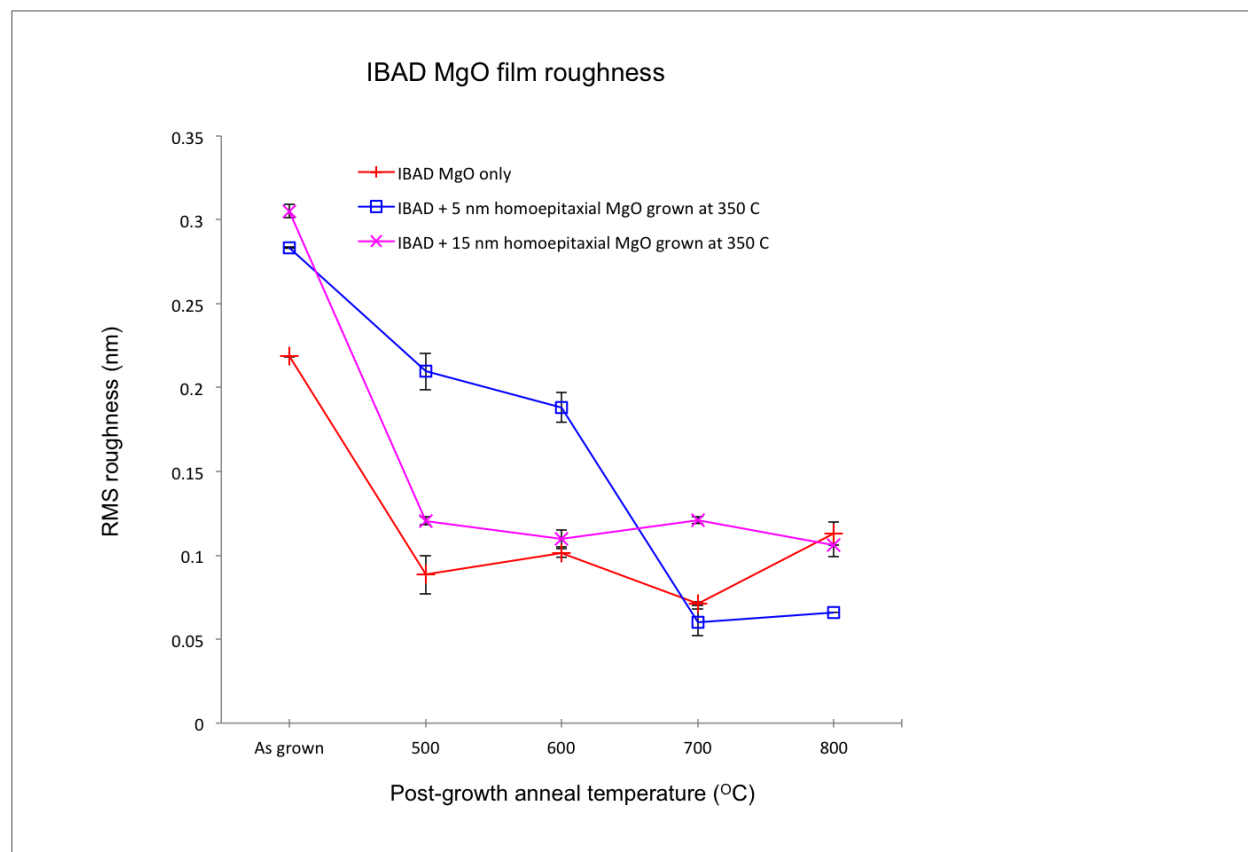

Figure 4.10: Roughness values for three different IBAD MgO films as-grown and after each post-growth anneal. Samples include IBAD MgO only, IBAD + 5 nm homoepitaxial MgO grown at 350°C, and IBAD + 15 nm homoepitaxial MgO grown at 350°C. Roughness calculated from lateral profiles of AFM images. Error bars determined by standard error of mean value from 2 measurements are included in plots, though most are very small and inside marker symbols.

These surface roughness results show that annealing decreases roughness on each of the three different IBAD and IBAD + homoepitaxial MgO films. The magnitude of decrease in roughness is very similar for each sample, giving more promise to the prospect of using thinner IBAD and IBAD + homoepitaxial MgO films without sacrificing film quality.

The decrease in roughness brought about by annealing correlates positively with the decrease in film stress caused by annealing. It appears that post-growth annealing has a beneficial effect on the quality of the IBAD and IBAD + homoepitaxial MgO films in terms of both film stress and surface roughness. Annealing provides the atoms with sufficient energy to reach this more stable state. These results are also promising for improving the quality of IBAD and IBAD + homoepitaxial MgO films while also decreasing thickness.

Chapter 5

Conclusion

5.1 Conclusion

The goal of this work was to further understand film stress in IBAD and IBAD + homoepitaxial MgO thin films. Specifically, this work sought to characterize the film stress and investigate the effect that annealing and growth temperature have on the IBAD and IBAD + homoepitaxial MgO film stress and surface roughness, two key aspects of film quality. Understanding and improving film quality help expand the uses and applications of IBAD and IBAD + homoepitaxial MgO films.

This dissertation work found that post-growth annealing decreases both stress and surface roughness in IBAD and IBAD + homoepitaxial MgO films. Additionally, this study found that an increase in growth temperature of the homoepitaxial layer also decreases film stress. Lastly, this work determined that the increased IAR used in IBAD MgO film growth, coupled with post-growth annealing may remove the need for the homoepitaxial layer when using IBAD MgO as an intermediate surface for growing epitaxial films on an amorphous platform.

The results of this work show that using a higher IAR during growth, increased growth temperature, and post-growth annealing of IBAD and IBAD + homoepitaxial MgO can be used to improve the quality of the films. This quality improvement may allow for the use of IBAD MgO only or thinner homoepitaxial layers in IBAD + homoepitaxial MgO films used as platforms for growth of epitaxial materials on amorphous membranes. Growing another film such as Ag or Fe on top of an IBAD MgO only film annealed slightly below 500 °C and an IBAD + homoepitaxial MgO film with a homoepitaxial layer grown between 425 and 500 °C followed by characterization of the epitaxial film (Ag, Fe, etc.) with X-ray diffractometry would more thoroughly test the effectiveness of annealing and growth temperature to improve the utility of IBAD MgO as a platform for epitaxial growth.

Future work is currently underway to measure the effect that annealing and growth temperature of the IBAD and IBAD + homoepitaxial MgO has on the quality of a film grown on top of the IBAD and IBAD + homoepitaxial MgO.

Chapter 6

Introduction and Background

6.1 Transfer in science education research

What is the purpose of taking and succeeding in a science course, specifically a chemistry course? Many students don't think beyond fulfilling major requirements or pre-requisites for an advanced degree in a health-related field. Of course, chemistry courses are required for good reason, so that students may apply the knowledge they acquire and method of thinking they practice in a chemistry course to solving problems in both their personal and professional lives. Part of the goals for any chemistry course includes the students' being able to apply their learning to an experience outside the classroom. In education research, this action is known as knowledge transfer.

Unfortunately, while most teachers want their students to be able to apply what they've learned to situations outside the classroom, the need to cover a substantial amount of material in a limited timeframe often limits time spent practicing knowledge transfer in a chemistry course. Consequently, knowledge transfer is not always an obvious goal to the students who may see chemistry as esoteric and not applicable to life outside the classroom. Without making this goal clear to the students, and without sufficient time to practice transfer, it's possible that students are not walking away from a chemistry course with an improved ability to apply their chemistry knowledge and thought process to everyday problems. In order to support transfer from the chemistry classroom, we must move toward a well-defined understanding of transfer. By deliberately measuring transfer in chemistry students, we can determine whether this learning goal is being accomplished and what can be done to improve this aspect of student learning in chemistry.

6.2 Previous research on transfer

Over the past century, there have been several studies aiming to define, model, and empirically measure knowledge transfer in science students of varying age and educational level. Several reviews explore the large body of literature on knowledge transfer [15], [33], [4], [14],

[11]. The great variation and lack of consistency in definition, theoretical framework, and empirical measurement methods of transfer in previous work is the source of many of the disagreements among findings.

Some of the early research on knowledge transfer took place over a century ago, by Thorndike and Woodworth [35]. Their work involved testing subjects' abilities to correctly estimate the areas of shapes. Subjects first practiced estimating unknown areas of rectangles while referring to rectangles with known areas. After making estimates, subjects were told the areas of their unknown rectangles. Subjects then estimated the areas of parallelograms, and then of irregular shapes, without any new references or ever being told the areas of these unknown shapes. The conclusions of this work were based on how close subjects' estimated areas were to the actual areas. The subjects' knowledge transfer was measured only by their resulting numbers. This study did not analyze the thought process subjects took in arriving at their answers. The researchers determined that practice with the rectangles did very slightly improve subjects' accuracy in estimating areas of parallelograms and irregular shapes. Conclusions were that some, but very little knowledge transfer occurred.

Some of the early work that focused specifically on knowledge transfer in chemistry was published in 1938 by Evelyn Mudge [27]. In her work, the researcher would verbally describe an everyday problem to chemistry students. Students were given a list of possible solutions to the problem, and they marked each solution as effective or not effective. An additional experiment in this same study involved chemistry students' reading a science-related news article. After reading the article, students answered a series of true or false questions about the article. This work, using both of these methods, concluded that knowledge transfer did occur and was increased significantly by taking a year of high school chemistry. While this study did find transfer, the multiple choice and true or false questions used to measure transfer substantially limited the possible responses students may have provided. While this limitation helped to simplify results and remove a source of subjectivity in analysis, it also prevented a great range of responses that may have shown a broader range of depth and detail in level of transfer. Furthermore, limiting responses using multiple choice and true or false does not simulate real world situations in which students will be using their knowledge transfer.

In spite of the above examples' somewhat successfully finding knowledge transfer, there are just as many studies that do not find knowledge transfer. In 1956, Burack and Moos published a study in which elementary school students were tasked with solving a mechanical puzzle, which required the application of centrifugal force [5]. The study allowed students to first solve the puzzle themselves without help. Students who were unable to solve the puzzle without help were then given help in various forms including theoretical descriptions of centrifugal force, examples of centrifugal force both outside and inside daily experience, and visual demonstrations of centrifugal force. The study found that none of the above interventions necessarily helped the students solve the puzzle. The researchers concluded that "knowing the principle basic to a solution of a problem does not necessarily enable the subject to apply the information to a new problem based on the principle" [5].

More recently, Shemwell, Chase, and Schwartz (2015) conducted experiments in which

students were given several empirical examples of manifestations of phenomena in physics, such as Faraday's Law [34]. Students were then asked to use the examples given to come up with a general explanation of what is happening, in hopes that students would hone in on the common underlying principle evident in all of the examples. The researchers concluded that "students do not spontaneously search for a general explanation across a set of manifestly related instances" [34].

Other empirical studies have found transfer in field experts but not in science students [14]. Detterman and Sternberg (1993), upon analysis of previous work on knowledge transfer, suggested that field experts only seem able to transfer knowledge because they have already encountered and been taught most of the examples in which their knowledge is applicable:

"...significant transfer is probably rare and accounts for very little human behavior..... We generally do what we have learned to do and no more. The lesson learned from studies of transfer is that, if you want people to learn something, teach it to them. Don't teach them something else and expect them to figure out what you really want them to do." [14]

The quotation above summarizes research on transfer from a perspective that many researchers do share. However, some researchers disagree that transfer is rare. Bransford and Schwartz (2001) make a compelling case for transfer's being more prevalent and common than many studies suggest [4]. They begin by analyzing the research methods from studies that conclude that transfer is rare. Most studies supporting that transfer is rare often searched for transfer in the form of analogical problem solving and direct application. In these types of studies, students are taught how to solve one type of problem and then are asked to solve a similar type of problem in which they could use the same method they had been taught but in a slightly different context. Students' success or failure to solve the new problem was used to determine if knowledge transfer was occurring or not [35], [17], [18], [4]. Indeed, many previous studies measured transfer as success or failure to solve a given problem, but did not analyze the process or approach students took when they did not arrive at the correct answer. Bransford and Schwartz suggested that transfer may be evident in the problem-solving process even if students do not reach the desired end-goal [4].

6.3 Improving measurement methods for transfer

As described in Section 6.2, a common problem in previous studies on knowledge transfer is the lack of sensitivity of the measurement methods: focusing on the successful attainment of a correct solution and failing to analyze the steps taken in problem solving. In response to this problem, recent work has been done by Sasson and Dori (2015) to evaluate student responses to transfer tasks with more sensitivity for the problem-solving process [33]. Sasson and Dori developed a theoretical framework that defined three attributes of any transfer-measuring task: Task Distance, Interdisciplinarity, and Skillset. When all three of these attributes are low in a given task, near transfer is being practiced. When all three attributes are high, far

transfer is being practiced. Assigning a value to each of these attributes places a transfer task somewhere on the spectrum of transfer task difficulties ranging from near to far transfer. In their study, students answered both near and far transfer questions in chemistry. Many of the transfer questions were open-ended, and a method of analysis was used to characterize responses more sensitively than a simple right or wrong. Their study found that students did show measurable transfer improvement after working through a computational chemistry laboratory program. The larger goal and focus of Sasson and Dori's work was to develop and test their theoretical framework to connect empirical studies to theoretical studies on transfer in science education.

6.4 Goals of this work

Using Sasson and Dori's methods and framework as a reference point, this dissertation work will aim to 1) develop transfer measurement methods that allow open-ended responses, 2) develop a method of analysis for these responses that looks for transfer in the problem-solving process, and 3) assess the methodology itself and its sensitivity, validity, and utility as a general transfer measurement technique for use across a broad range of expertise levels in chemistry.

Sensitivity of transfer measurement methods

In order to accomplish the goal stated above, this dissertation work will design, analyze, and evaluate a set of questions that elicit responses showing transfer at increasing levels of depth and detail from introductory chemistry students, organic chemistry students, and field experts including graduate students, postdoctoral researchers, and professors of chemistry. Responses, whether traditionally "right" or "wrong" will be analyzed in close detail to measure the degree of transfer shown in the responder's thought process and pathway. Analysis will measure how far along the pathway a response has reached toward becoming a fully descriptive, complete, and correct response. Additionally, because "transfer is linked closely to how knowledge is represented in students' memories," [33] responses will also be analyzed for the way the responder pictures the system in question.

Broad applicability of transfer measurement methods

This work will aim to design transfer questions that also may be used in a variety of future empirical studies on transfer. Many transfer tasks and measurement tools used in previous work are intended for a specific type of student studying a specific model or problem-solving method. There is lacking a set of transfer tasks that may be used to measure transfer in and distinguish between students and practitioners of chemistry with a broad range of educational backgrounds and expertise in chemistry. Using broadly applicable measurement

tools for transfer in chemistry education can interconnect future work on transfer so that a more widely-supported and cohesive understanding of transfer can be reached.

Finding shared attributes of sensitive and broadly applicable transfer measurement tools

The development and analysis of transfer questions described above will also serve the larger purpose of evaluating the questions themselves. Each question developed and tested will be evaluated based on the extent to which it measures transfer in each category of responder, ranging from introductory chemistry student to field expert. This focus on evaluation of the measurement tool will also fill a gap in the literature and in the chemistry classroom. Researchers and instructors often focus on student answers in the context of the student's own thinking but do not often consider the answer in the larger context of the question being asked. It is useful to analyze the researcher's or instructor's assumptions about the question itself and how it might elicit certain types of responses from the students by focusing and leading the student to a specific answer or set of answers.

I suggest that a set of short-answer, easy-to-understand questions covering common topics learned in lower division chemistry courses and eliciting answers spanning a range of depth and detail can be used to measure knowledge transfer in undergraduate students and experts in chemistry. Utility of questions is demonstrated by eliciting an expected improvement in depth and detail of response as expertise level is increased.

Integrating this work into the existing literature

Because the body of existing literature on knowledge transfer includes variation in definition, theoretical framework, and methods of empirical measurement of transfer, I'll be clear in where this work fits in among the existing literature. This dissertation work will assume the definition of transfer as being the effect of existing knowledge, abilities, and skills on the learning or performance of new tasks [26], [11]. More specifically, this work will focus on and contribute to empirical measurements of transfer as the application of previous knowledge learned in a chemistry course to situations encountered outside the classroom.

Since theoretical framework for transfer is weak or absent in many empirical studies [15], this work will synthesize some parts of theoretical framework that best explain its findings while also mapping findings onto the theoretical framework suggested by Sasson and Dori (2015) [33].

6.5 Summary

Much of the existing literature on knowledge transfer concludes that transfer is rare and does not occur spontaneously. However, studies supporting that transfer is rare often use methods that focus on binary success or failure to solve a problem correctly and do not

analyze thought process. More recent studies have found evidence of knowledge transfer by using more nuanced analysis of responses to transfer tasks.

This dissertation work aims to build upon these more recent studies by developing transfer questions that allow open-ended responses, developing a method of analysis for these responses that looks for transfer in the problem-solving process, and assessing the methodology itself and its sensitivity, validity, and utility as a general transfer measurement technique for use across a broad range of expertise levels in chemistry.

Ultimately, a set of broadly applicable questions and associated method of response analysis that are able to measure transfer in and distinguish between a broad range of expertise in chemistry students and experts will be produced and evaluated. This will provide researchers and instructors of chemistry with a set of questions and response analysis useful for transfer measurement in a variety of settings as well as a description for what characteristics make these questions useful for the above-stated purpose so that researchers and instructors may produce more of their own question with a similar purpose in mind.

Chapter 7

Methods: Development and testing of tools to measure transfer

7.1 Introduction

The researchers in this dissertation work sought to design and test chemistry questions that would elicit and measure knowledge transfer in undergraduate chemistry students as well as expert level chemists. This chapter details the approach to and execution of developing transfer questions and lists the transfer questions themselves. The methods used to collect responses to the transfer questions are described below along with the complex and nuanced methods of evaluating transfer question responses to ultimately measure knowledge transfer. The three levels of expertise of the 33 subjects who provided responses to the transfer questions are also discussed, and expected range of response across the three expertise levels is described.

7.2 Transfer question design

Questions were designed starting from a common, real world experience that is shared by most people and that can be explained using models learned in an introductory or general chemistry course. Inspiration was not derived from chemistry textbooks, rather from the experiences of the researchers that are common to many people living in the United States at the time of the research (2014-2016). The questions, by design, require students to transfer knowledge they've learned in their chemistry course(s). Because these questions would be tested on students in various chemistry courses, the questions were designed to be easily understood even by somebody who'd had no educational background in chemistry. All questions are short-answer and open-ended to allow for the sensitive analysis of the nuances in the responders' thought process.

These questions are quite different from typical questions asked in a lower level chemistry course or found in a lower level chemistry textbook. Many questions asked in a lower level

chemistry course require use of formulae to calculate values describing a molecule or system of molecules. More importantly, most questions asked in these courses explicitly describe atoms, molecules, and nanoscale interactions in the question itself, removing the need for the student to make the connection between the macroscale world and the nanoscale world. The transfer questions designed for this work do not explicitly describe the nanoscale world, but rather ask implicitly that the students draw the connection between the macroscale observation described in the question and the nanoscale chemical models they've learned. If the responder can correctly recognize the applicable chemical model(s) that can describe the macroscale observation in the question, it is anticipated that the question will be answered with increasing levels of depth and detail consistent with the education and practice in chemistry of the responder.

The set of questions as a whole was designed to cover most of the fundamental models covered in a typical introductory chemistry course: Coulomb's law, the first and second laws of thermodynamics, conservation of mass, kinetic theory of gases, quantum mechanics and bonding, reaction kinetics, and acid-base chemistry. With the above in mind, the following 11 questions were developed and tested:

1. You eat pizza for dinner, and now your hands are greasy. Since you do not have soap or paper towels, you rinse the pizza grease off your hands with water, but it is not working! Your hands are still greasy after running them under the faucet. Why?
2. After you turn off your car's engine, you notice some small drops of water coming from the tailpipe. Your mechanic says this is normal and does not reflect a problem with the car. Where is this water coming from?
3. After you get out of a swimming pool, you feel chilly even on a hot sunny day. You only feel warm again after you dry yourself off. Why does your body feel colder when it is wet compared with when it is dry?
4. A baseball is hit into a parking lot and hits a car. Fortunately, the ball just hit the car door and left a dent. If it had hit the window, it surely would have shattered. Why does glass shatter, whereas metal dents?
5. You just picked up a friend from the airport. She pulls out two water bottles from her backpack. One bottle is empty and squished. The other bottle is full of water and not squished. Why?
6. You buy a hot coffee with sugar. Suppose you drink half of it, and put the rest in the refrigerator to drink as iced coffee later. The next morning, when you take the coffee out of the refrigerator, you notice sugar crystals that were not there before. How can you explain what happened?

7. Why do you need to recharge the battery on your cell phone? What happens inside the battery when you do this?

8. The decomposition of sodium azide (NaN_3) can be used to inflate an airbag in a car.



Based on your understanding of chemistry, what is one question you would want to ask to be sure that the airbag will inflate properly and safely?

9. How is it possible to eat every day and not gain weight? Only about 15% of the mass from the food you consume is eliminated through the bladder and large intestine. Where does the other 85% go?

10. Candy with a coating of malic acid is sour. Suppose you want to make the candy super sour. How would you go about choosing a different coating?

11. In order to make bread dough, fermentation produces CO_2 , causing the dough to rise. The CO_2 also lowers the pH of the dough. However, the chemical species in other ingredients such as milk can mitigate this pH change. Milk is slightly acidic with a pH around 6.6. How could it prevent the CO_2 from making the dough more acidic?

Each question was followed by the following three sub-questions:

A. What chemistry principles or concepts might you use to answer this question?

B. What other information might you want to look up to help you answer this question?

C. Try to answer the question using these chemistry principles and concepts. Please make your answer as detailed and specific as you can.

The sub-questions listed above were included to facilitate the demonstration of the responders' thought processes in answering each question and were specifically inspired by Bransford and Schwartz (2001) [4].

As described in Chapter 6 of this dissertation work, Sasson and Dori's framework helps connect empirical studies of transfer with a theoretical framework. They've defined three attributes of any transfer-measuring task: Task Distance, Interdisciplinarity, and Skillset. When all three of these attributes are low in a given task, near transfer is being practiced. When all three attributes are high, far transfer is being practiced. Assigning a value to each of these attributes places a transfer task somewhere on the spectrum of transfer task difficulties ranging from near to far transfer [15].

All of the questions above have a large task distance, meaning they may be very different from the typical questions students practice answering as part of their coursework. Interdisciplinarity is relatively low for most of these questions. The questions are designed

to be answered with one, sometimes two fundamental chemistry models. However, while interdisciplinarity is not required to answer most questions, some questions do provide the opportunity for interdisciplinarity. Specifically, questions 1 and 9 allow responders to draw connections between chemistry and biology. Questions 2 and 7 may draw connections with physics and materials science and engineering. Skillset is relatively high for most questions because responders are required to apply chemical models on their own by recognizing the applicable chemical model and making the connection between the nanoscale chemical model and the macroscale observation. Overall, these questions would be described as far transfer tasks according to Sasson and Dori's three-attribute transfer skills framework. This makes sense, since the questions are designed to measure transfer over a range of expertise levels in chemistry. The questions are designed to be accessible and at least partially do-able by introductory chemistry students yet challenging enough to allow more advanced undergraduate students and field experts to show an increased depth and detail in their response relative to lower-level undergraduate students.

7.3 Testing transfer questions

Questions were organized into an online survey platform allowing responders to type answers into a designated space. The survey was distributed to three different groups: six students at the end of an introductory chemistry course at a California Community College; 21 students at the end of an organic chemistry course at a California Community College, and six field experts including two chemistry professors, two postdoctoral researchers in chemistry, one recent PhD in chemistry working in patent law, and one chemistry graduate student. Responders were given approximately a two-week window during which to complete the questions and were asked not to use any outside resources such as textbooks, the internet, or other people.

7.4 Evaluating answers to transfer questions

Upon analysis of student and expert responses to the transfer questions developed, responses were tagged in three distinct categories:

1. Transfer pathway
2. Logical flow of ideas
3. Scale of model used

Transfer pathway

This category analyzes the various points students reached in their process of answering each transfer question. The points found included

- R: Recognition of applicable chemical principles
- U: Understanding of those chemical principles
- A: Application of those chemical principles
- CA: Correct application of those chemical principles

For each of the four points listed above, each answer was given a score of 0, 1, or 2. 0 meant this action was absent in the response; 1 meant this action was present but not complete or correct; and 2 meant this action was present, complete, and correct in the response.

Recognition (R) means the response shows an identification of the chemical principle that can be used to explain the observation in question. For example, in response to question 1, which asks about rinsing grease off of one's hands, the following would be tagged as recognition:

"Molecular dipole moment and resulting intermolecular forces are important here."

Understanding (U) means the response explicitly shows understanding of the chemical principle being used, whether or not the principle is applied correctly. The response must describe or summarize the chemical principle being used. In response to question 1, the following would be tagged as understanding:

"Bond dipole moments result from a difference in electronegativity between two atoms bonded together. The vector sum of the bond dipole moments in a molecule makes a molecular dipole moment. Molecules with similar dipole moments interact with each other more favorably than molecules with different dipole moments."

Application (A) means the response makes a connection between the chemical model and the macroscale observation described in the question. Application does not necessarily mean correct or accurate application; it only means that the response included some attempt to connect chemical models to the macroscale observation in the question. In response to question 1, the following would be tagged as application:

"The grease molecules have a specific dipole moment, and the water molecules have a specific dipole moment. The difference between these dipole moments affects the interaction between a grease molecule and a water molecule, which determines whether or not water can remove grease from your hands."

Correct application (CA) means the response applies a correct chemical model in a correct way to answer the question accurately. Correct application may imply understanding, but implied understanding was not tagged as understanding. Correct application was the most meaningful measure of a complete and correct answer to the question. In response to question 1, the following would be tagged as correct application:

Bloom's Taxonomy

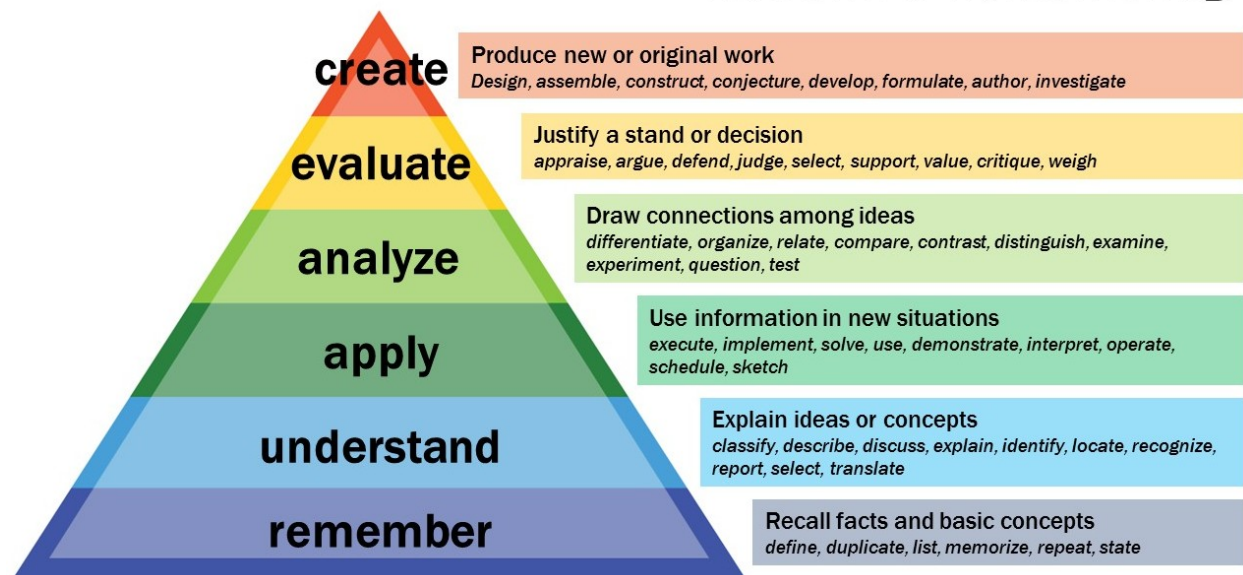

Figure 7.1: Bloom's Taxonomy [2]: a hierarchy of educational learning goals with increasing depth and complexity. The first three (remember, understand, apply) are observed in responses to transfer questions in this work. The higher level learning goals of the three are observed with increasing frequency as expertise level of responder increases.

"The grease molecules and the water molecules have very different dipole moments. Therefore, these two types of molecules do not interact favorably with each other. It is more favorable for the water molecules to interact with themselves and for the grease molecules to interact with themselves. Because of this, grease will not dissolve in the water, so you will not be able to remove grease from your skin using only water."

Recognition, understanding, and application map loosely onto Bloom's taxonomy (Figure 7.1) [2]. Recognition (R) is comparable to remembering in Bloom's Taxonomy, and bleeds into understanding in Bloom's Taxonomy as well. In order for students to recognize the applicable chemical principle, they must also understand something about the connection between the question being asked and the chemical principle without the principle being explicitly identified for them. Understanding (U) is comparable to understanding in Bloom's Taxonomy. Application (A) is comparable to applying in Bloom's Taxonomy. Correct application (CA) is a combination of understanding and applying in Bloom's Taxonomy. In order to correctly apply the recognized chemical principle, the student must also understand something about that principle.

Logical flow of ideas

This category analyzes the responder's tendency to think like a scientist in a logical and cohesive flow of ideas. For logical flow of ideas, each response was given a score of 0, 1, or 2. A score of 0 meant that this action was absent in the response; a score of 1 meant this action was present but not complete or correct; and a score of 2 meant this action was present and complete in the response. In response to question 1, the following would be tagged as having a logical flow of ideas:

"Bond dipole moments result from a difference in electronegativity between two atoms bonded together. The vector sum of the bond dipole moments in a molecule makes a molecular dipole moment. Molecules with similar dipole moments interact with each other more favorably than molecules with different dipole moments. If the grease is not coming off your hands from water, it must mean that water molecules and grease molecules have very different dipole moments, and therefore do not interact favorably. The grease wants to stick to itself more than it wants to stick to the water, and the water wants to stick to itself more than it wants to stick to the grease."

Scale of model used

This category analyzes the level at which the responder was describing the system in question. The two levels found included

- A. Macroscale, or system-wide view
- B. Nanoscale, or molecular level view
 - i. Structural view in which the responder actually described arrangements of atoms in a molecule relative to one another.

Categorizing responses in this way is similar to Sasson and Dori's rubric for assessing students' far transfer skill [33]. The rubric used in this dissertation work has the added sub-level of structural view. Answers categorized as having a structural view describe atomic arrangements and bonds between atoms within a single molecule. Each response was given a binary score of 0 or 1 for each of the two levels and one sub-level listed above. A score of 0 means this scale of model is not present in the response. A score of 1 means that this scale of model is present in the response. Only responses receiving a score of 1 for nanoscale are able to receive a score of 1 for structural. In other words, not all nanoscale responses also include a structural view, but all structural responses do include a nanoscale view. Answers tagged as having a macroscale view describe the system as a whole rather than individual molecules in the system. In response to question 1, the following would be tagged as having a macroscale view:

"Like dissolves like, and water and grease are not alike. Therefore, grease will not dissolve in the water."

Answers tagged as having a nanoscale view described individual atoms or molecules. In response to question 1, the following would be tagged as having a nanoscale view:

"The grease molecules have a specific dipole moment, and the water molecules have a specific dipole moment. The difference between these dipole moments affects the interaction between a grease molecule and a water molecule."

Answers tagged as having a structural view described atomic arrangements and bonds between atoms within a single molecule. In response to question 1, the following would be tagged as having a structural view:

"Bond dipole moments result from a difference in electronegativity between two atoms bonded together. The vector sum of the bond dipole moments in a molecule makes a molecular dipole moment. Molecules with similar dipole moments interact with each other more favorably than molecules with different dipole moments."

7.5 Expected response range

In order to determine which of the 11 transfer questions are the most useful in measuring transfer, it is assumed that as level of expertise in chemistry increased, depth and detail of response to each transfer question should increase. Three levels of expertise were measured:

1. Students at the end of a college level introductory chemistry course.
2. Students at the end of a college level organic chemistry course.
3. Experts in the field including senior-level graduate students, postdoctoral researchers, and professors.

The transfer questions span a range of general chemistry topics, only some of which are explicitly covered in an organic chemistry course. However, increased depth and detail in answer was nonetheless expected from introductory chemistry students to organic chemistry students. Reasons for this expectation include increasing time on task as well as the type of thinking employed in organic chemistry that is distinct from that used in introductory and general chemistry.

Experts have spent greater time on task studying and practicing chemistry than organic chemistry students, and organic students have spent more time on task studying chemistry than introductory chemistry students. This increase in time on task gives students and experts more practice in thinking like a scientist and thinking like a chemist. Even those topics learned in their introductory chemistry course that are not explicitly covered again may be easier for more advanced students to understand and therefore apply to a transfer question.

The general skill of thinking logically and picturing atomic and molecular interactions can be applied to many types of chemical principles and models.

Organic chemistry is also usually the first chemistry course students take in which a solution to a problem cannot always be calculated using a learned formula. Organic students are introduced to the ambiguity and gray areas that show up when using different chemical models that may conflict with one another. For example, observations in organic chemistry are often explainable by undergraduate organic students as some combination of electronic effects and steric effects. While the root of both of these effects rests in Coulomb's law, undergraduate organic students do not learn how to fully calculate the values representing the magnitude of these effects and must therefore accept some degree of ambiguity in using these more qualitative models in predicting reaction outcomes. It is likely that, because organic students have had some practice in solving problems without calculating values but rather by picturing molecular interactions and the manifestations of Coulomb's law that affect reaction outcomes, they are more comfortable with and capable of solving the open-ended transfer questions developed in this work.

It is a bit more obvious how and why the level of thinking practiced by experts makes them able to answer the transfer questions with even more depth and detail. Experts have practiced considering and applying multiple different models and chemical principles to one situation. They are able to think in a more nuanced and detailed way than undergraduate chemistry students.

7.6 Summary

Eleven transfer questions were written covering most of the models learned in an introductory or general chemistry course at the undergraduate level. Questions were designed to be open-ended and digestible by students with little to no chemistry background while providing the opportunity for more expert level responders to show greater depth and detail in their response. A method of analysis was also developed to characterize transfer pathway, logical flow of ideas, and scale of model used in each response. Questions were answered by 27 students and 6 experts. A summary of response data as well as detailed analysis and sample responses are provided in the following chapter.

Chapter 8

Results: Sensitivity of transfer questions

8.1 Introduction

This chapter first summarizes the analysis of responses by level of expertise of responder for each transfer question. This chapter then provides a detailed qualitative analysis of responses, including specific examples of responses from each level of expertise of responder for each question. Subsequently, analyzed data from all questions is used to determine the attributes that the most useful and sensitive transfer questions share, as well as the attributes that the least useful transfer questions share. Lastly, a model is proposed to describe the connection between transfer question attributes and levels of expertise between which a given transfer question may best distinguish.

8.2 Summary of evaluated responses

Each response to the transfer questions in Section 7.2 was evaluated using the categories described in Section 7.4. These categories include four points along the transfer pathway (recognition, understanding, application, and correct application), logical flow of ideas, and scale of model used (macroscale, nanoscale, and structural). In order to summarize the scores for each question's response for each category of responder, scores from all responses to each question within each level of expertise were added up. From this sum, a percentage was calculated in which 100% is defined as the total score that would come from every responder in that level of expertise scoring the highest possible in that category. The results are plotted in Figures 8.1, 8.2, 8.3, 8.4, 8.5, 8.6, and 8.7.

These summary plots show, for the most part, the expected response range described in Section 7.5. On most categories scored, for most questions, experts score higher than organic students, who score higher than introductory students. This shows an increasing level of depth and detail of response as expertise level increases. However, some questions

elicit a broader and more distinguishable range of responses between the three expertise levels than others. Specifically, questions 1, 3, 5, 6, and 11 show the best spread of responses while still showing some transfer from all levels of expertise tested. Questions 4, 7, 9, and 10 show the most unexpected range of responses. For questions 4 and 7, the change in depth and detail of responses does not correlate as expected between introductory chemistry students and organic chemistry students. For questions 7, 9, and 10, the expected correlation is present for all categories. However, it appears that these three questions did not allow responders at the introductory chemistry level to show chemistry knowledge transfer.

The understanding piece is missing in many transfer question responses, especially from the introductory chemistry students. I suggest that this is not only okay but may be beneficial to the utility of these questions in measuring transfer. Transfer is not primarily about showing a detailed understanding of a model. Transfer is about *using* that model to explain an everyday occurrence. The questions are designed to focus the responder on the application, not the explication of the chemical principles they've learned in their chemistry course. Introductory chemistry students especially may be overwhelmed and confused by being asked to do too many things in one question, such as explain a model in detail and then apply it correctly to the question being asked. Because detailed comprehension is not the primary interest in application and transfer, these questions are effective at testing application and transfer specifically without overloading the responder with the need for a detailed explanation of the applicable model, which may show up at the expense of proper application and transfer of the model used.

Furthermore, objective evaluation of a student's response is more likely when the question elicits a more focused action from the responder. This is not to say that these questions elicit a narrow range of responses. Within the task of answering the transfer question, the responder may still go through the several pieces of a complete response as described in Section 7.4.

Figure 8.8 summarizes an additional piece found only in question 4, which asks about glass shattering vs. metal denting, question 9, which asks how one can eat every day and not gain weight, and question 10, which asks how to make a super sour candy coating. These three questions elicited common misconceptions, and responses to these questions were additionally scored in a misconception category with either a 0 meaning no misconception, or a 1, meaning the response showed a misconception. These results are summarized in Figure 8.8. This plot shows that both introductory and organic students are more susceptible to the misconceptions than field experts.

Question 2, which asks about liquid dripping from a car's tailpipe, and question 8, which asks about sodium azide decomposition used in airbags, are not discussed in further detail in the following sections, and are omitted from plots of the summarized data. Question 2 seemed to reflect more about the responder's previous knowledge of how cars work and less about his or her ability to apply understanding of combustion. Question 8 showed almost no range in responses. Responders of all levels were able to come up with a reasonable question to ask about the reaction used to inflate airbags in motor vehicles. This question seems too open-ended and elicited too many possible responses to measure transfer sensitively.

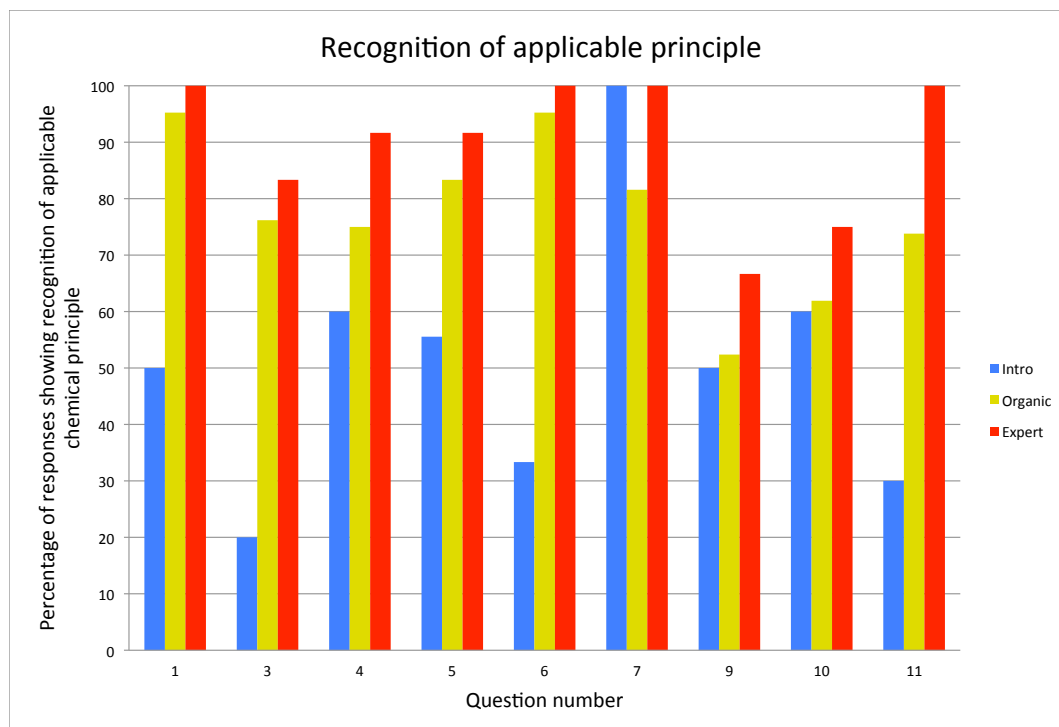

Figure 8.1: Percentage of responses showing recognition of applicable chemical principle needed to answer the question, separated by question (x axis) and level of expertise of responder (Introductory Chemistry student, Organic Chemistry student, field expert). A significant percentage of respondents in each level of expertise were able to recognize the applicable chemical principle for each question. That responders with a range of expertise levels are able to recognize the applicable chemical principle makes these questions useful for showing and measuring transfer across a range of expertise levels. However, it can still be seen that percentage of responses showing recognition of the applicable chemical principle increases as expertise level increases.

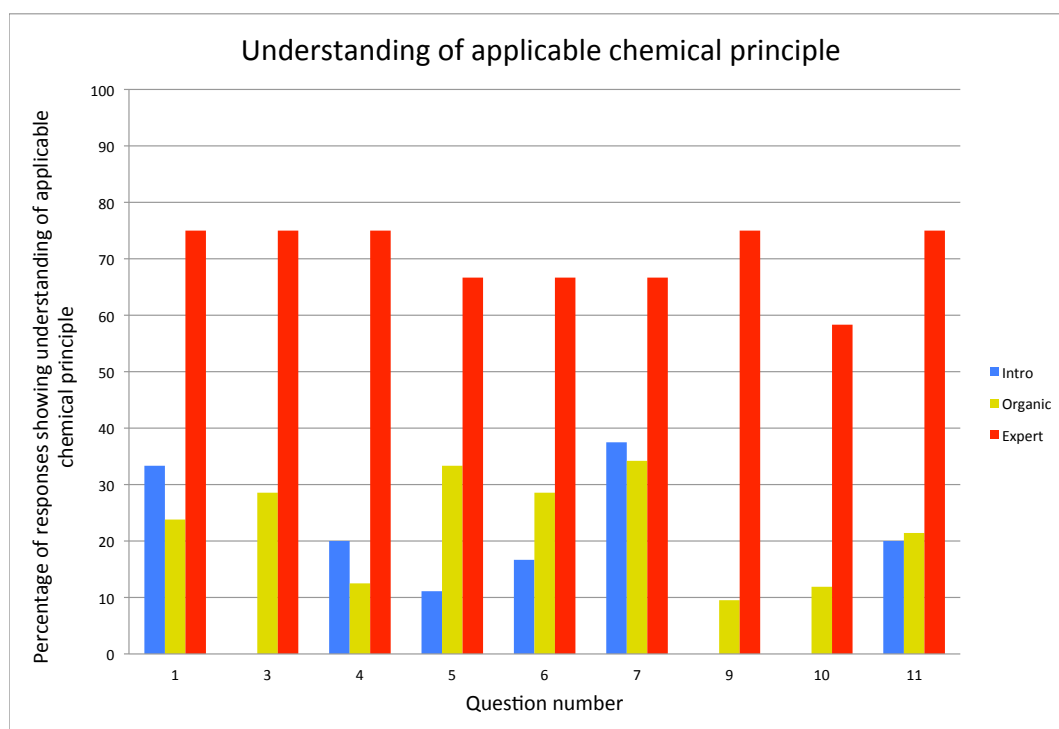

Figure 8.2: Percentage of responses explicitly showing understanding of applicable chemical principle needed to answer the question, separated by question (x axis) and level of expertise of responder (Introductory Chemistry student, Organic Chemistry student, field expert).

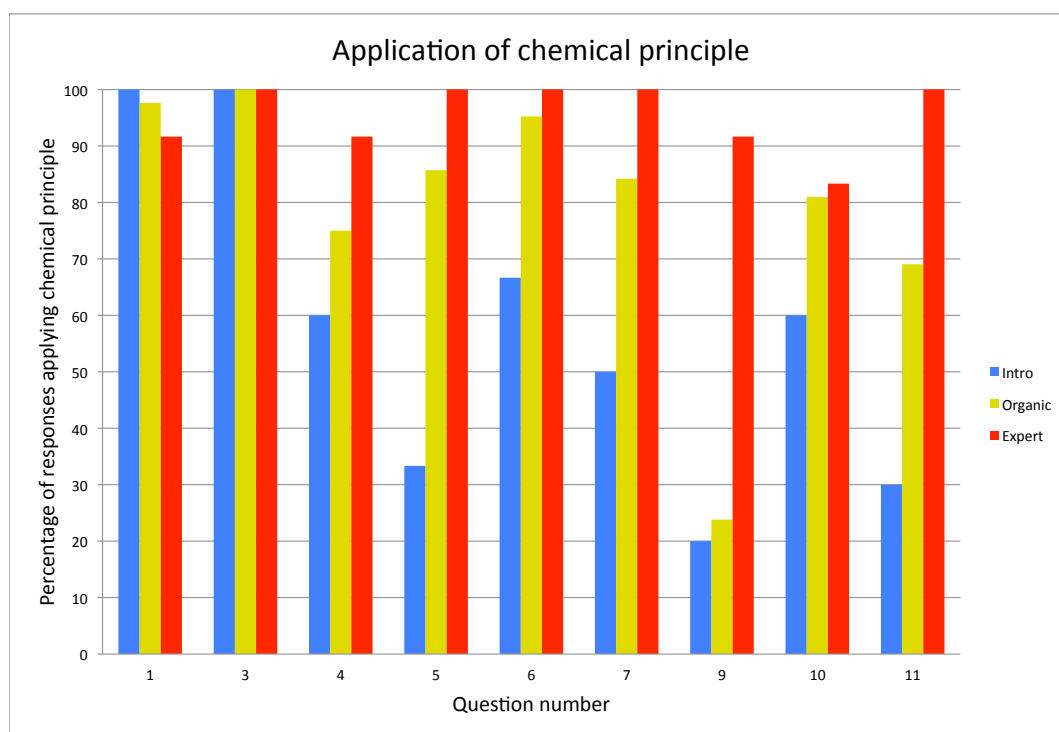

Figure 8.3: Percentage of responses showing application of chemical principle needed to answer the question, separated by question (x axis) and level of expertise of responder (Introductory Chemistry student, Organic Chemistry student, field expert). Note that application of a chemical principle does not necessarily mean responder applied the correct chemical principle, only that he or she made a connection between a chemical principle and the macroscale observation described in the question.

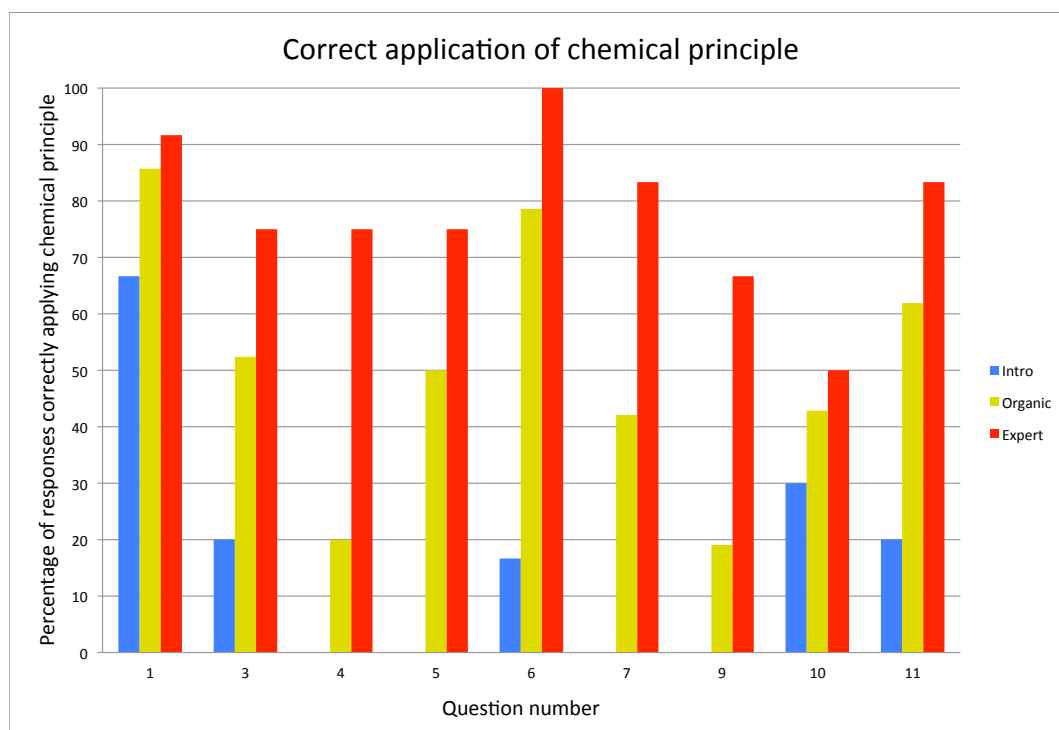

Figure 8.4: Percentage of responses showing correct application of chemical principle needed to answer the question, separated by question (x axis) and level of expertise of responder (Introductory Chemistry student, Organic Chemistry student, field expert). This category is the closest measure of the responder's complete and correct answer to the question.

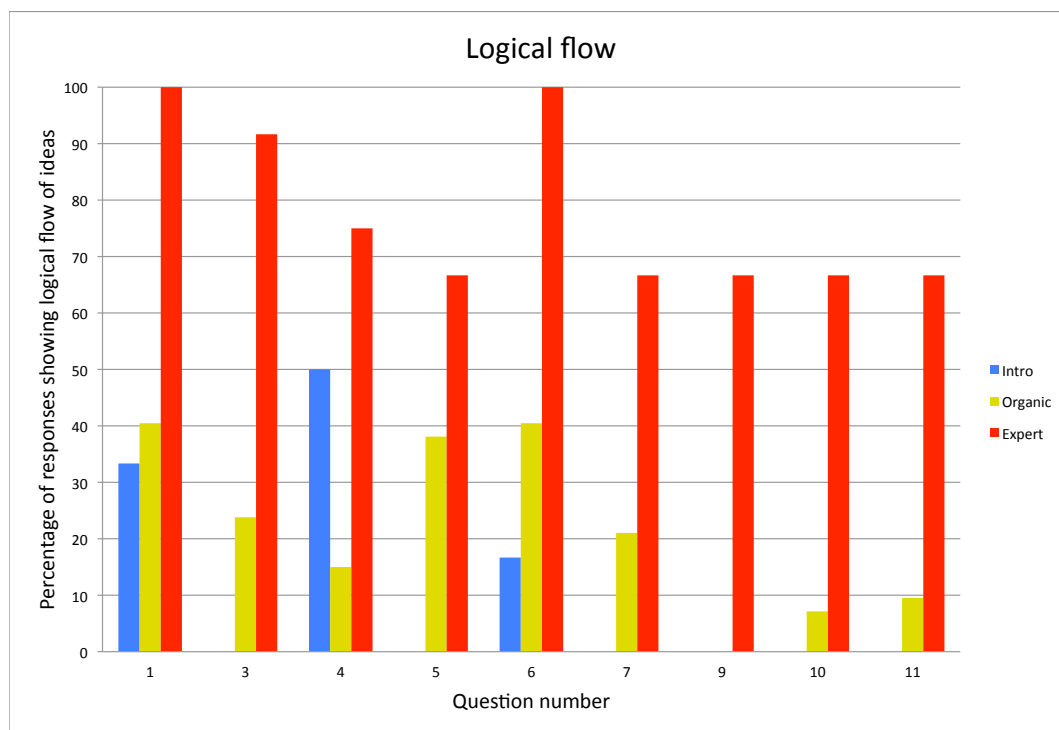

Figure 8.5: Percentage of responses showing logical flow and connection of ideas. This may also be described as thinking like a scientist. Separated by question (x axis) and level of expertise of responder (Introductory Chemistry student, Organic Chemistry student, field expert).

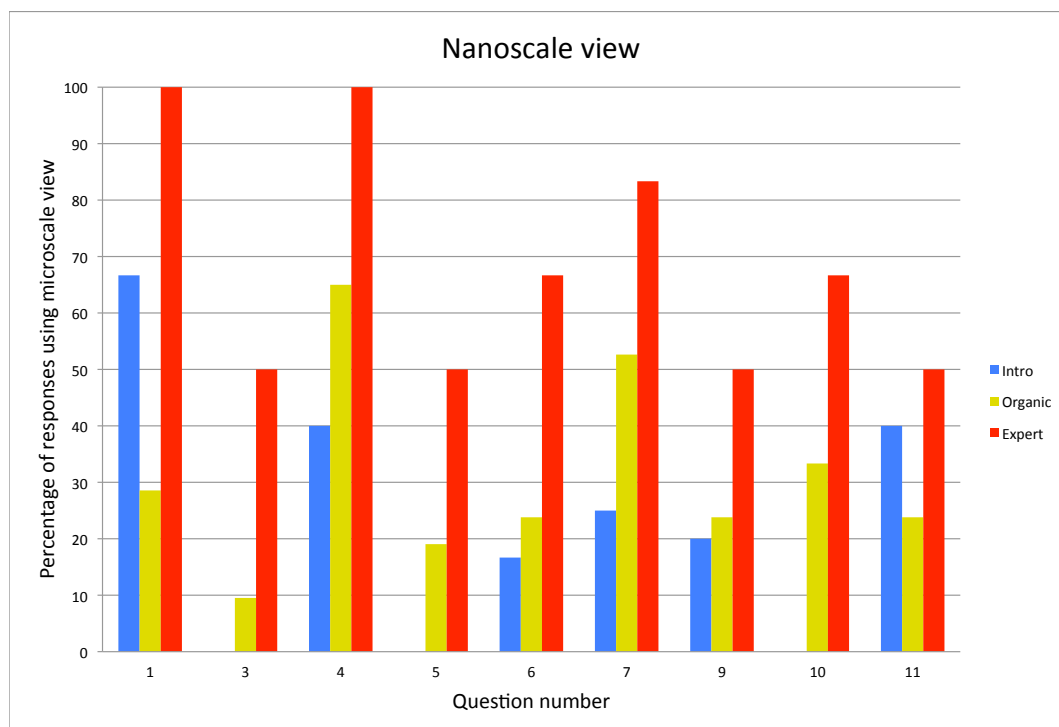

Figure 8.6: Percentage of responses using a nanoscale view to answer the question. This may also be described as thinking like a chemist. Separated by question (x axis) and level of expertise of responder (Introductory Chemistry student, Organic Chemistry student, field expert).

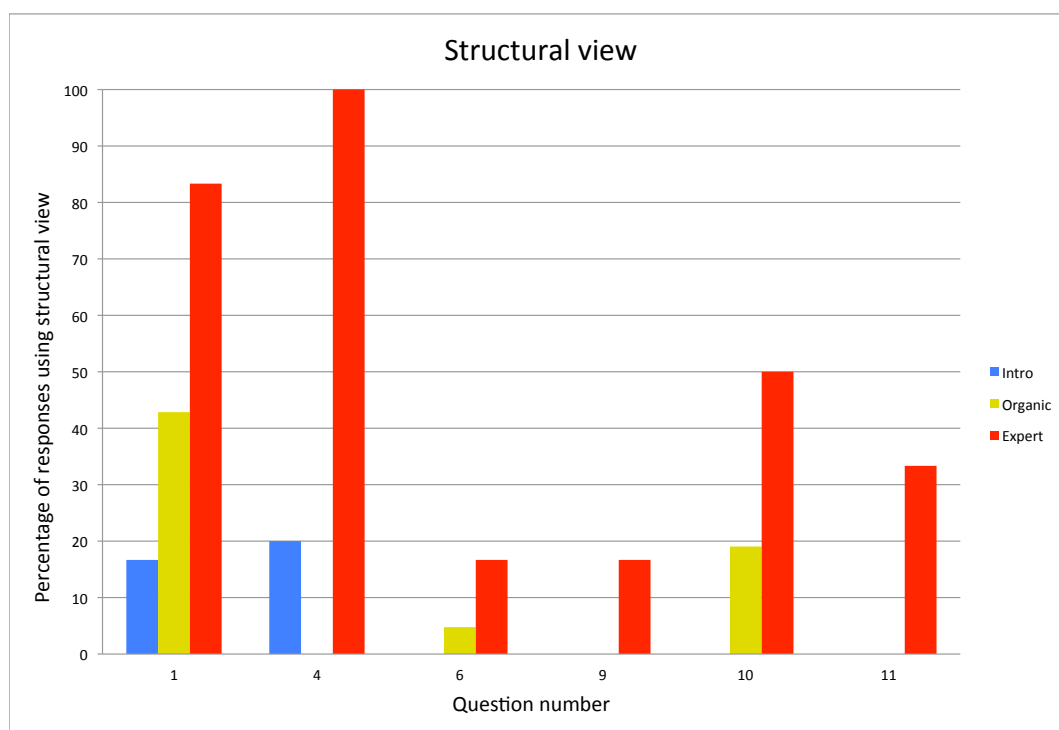

Figure 8.7: Percentage of responses using a structural view to answer the question. A structural view includes a nanoscale view with the addition of description of molecular structure and bonding. Separated by question (x axis) and level of expertise of responder (Introductory Chemistry student, Organic Chemistry student, field expert). Notice that not all questions are included in this figure, as some questions did not elicit a structural view from any responders.

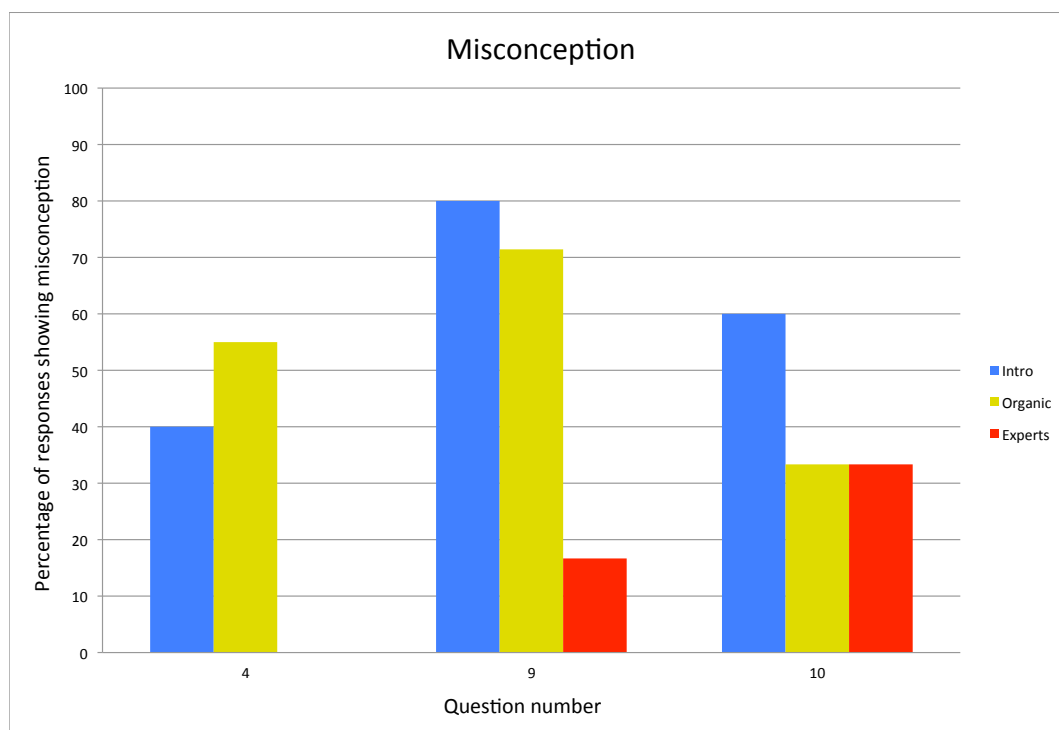

Figure 8.8: Percentage of responses showing a misconception in the answer to the question. Separated by question (x axis) and level of expertise of responder (Introductory Chemistry student, Organic Chemistry student, field expert). Note that only the three questions that elicited common misconceptions are included in this figure.

8.3 Qualitative analysis of each question

Below, I will address each question individually and describe the differences and commonalities seen in responses from each level of responder. Illustrative examples are also provided from each category of responder for each question. A summary of the tagged categories for each question is shown quantitatively in Figures 8.1, 8.2, 8.3, 8.4, 8.5, 8.6, 8.7, and 8.8.

1. You eat pizza for dinner, and now your hands are greasy. Since you do not have soap or paper towels, you rinse the pizza grease off your hands with water, but it is not working! Your hands are still greasy after running them under the faucet. Why?

Introductory Chemistry students: Two thirds of students took on a nanoscale view to picture grease and water molecules. Only half of the students recognized the applicable principle of bond polarity and correctly applied it to reach an accurate answer. Ex:

”This happens because the grease molecules do not bond to the H₂O molecules. The grease is non-soluble in water, it therefore only comes off if it is forcefully pushed off or it’s molecularly attached to something else, like soap.”

The rest of the introductory chemistry students applied a different chemical principle:

”The water is unable to completely integrate into oil like a liquid. A mechanism possibly electronegative forces of hydrogen repel the oil and the electronegativity of water make the water more likely to cohere to each other.”

Organic chemistry students: Most students recognized the principle of bond polarity and correctly applied it to answer the question accurately. Several students also explicitly demonstrated their understanding of polarity and solubility and showed a logical flow and connection of ideas in their answer. Some students also discussed molecular structure, an aspect absent in the introductory chemistry students’ answers. Answers also include more nuance and recognition of limitations of chemical models. In the example below, the student’s attempt at connecting chemistry with biology is evident. Ex:

”Grease is primarily a non polar compound, namely an oil that exists as a long chain of hydrocarbons. This makes it almost entirely, if not completely, insoluble in water since water interacts with polar compounds. Furthermore, one’s skin is composed of hydrocarbons due to the cell membranes that make up one’s body. The oil would be able to interact with it and thus adhere to one’s skin fairly easily in comparison to water.”

Experts: All responders recognized the principle of bond polarity, specifically hydrogen bonding. Many responders went further than simple ”like dissolves like” and compared the energetic cost and benefit of interactions between two grease molecules, two water molecules, and a water and grease molecule. This showed a much deeper description of the system than

the student responders showed. Most responders showed their understanding of the principle they applied and correctly applied this principle. All responders used a logical flow of ideas in their responses and took on a nanoscale and often structural view of the system. Ex:

”Molecular structure influences macroscopic properties like polarity and solubility. Things that feel greasy are probably long chain hydrocarbons with weak intermolecular forces. Water on the other hand is a polar molecule with strong attractions between molecules. The fats in the pizza grease are not soluble in the water. For one compound to dissolve in the another, there has to be a net benefit energetically whether from an enthalpy (bond making, IMFs) perspective or an entropy (increase in disorder through mixing). I suspect that the main argument for pizza grease not being soluble in water is that the IMFs between the grease and water are weak compared to grease-grease or water-water. So grease would associate with other grease vs. water.”

3. After you get out of a swimming pool, you feel chilly even on a hot sunny day. You only feel warm again after you dry yourself off. Why does your body feel colder when it is wet compared with when it is dry?

Introductory chemistry students: Most students answered in terms of heat transfer between water and skin. Most students described the water as drawing heat from the body in some way, but only one student specifically considers the process of vaporization as being responsible for this transfer of heat from the skin. Ex:

”The water is basically drawing energy from the system (you) and heat is essentially being dissipated. That is why you feel cold when you are wet because the water has properties to do that.”

Organic chemistry students: Most students answer in terms of heat transfer and do consider the process of vaporization as being the key to the person’s feeling cold. Several students also answer in a logically connected set of ideas that draws a string between the fundamental principle of heat of vaporization and the observation of a person feeling cold when wet. Some students also explicitly show their understanding of heat transfer in their answer as well as map this example onto other examples such as sweating during exercise. Ex:

”Evaporation uses energy which means it’s an endothermic reaction. The evaporating water takes heat (energy) from your skin to evaporate causing you to feel chilly. This is why you sweat when you exercise to allow your body to dump the excess heat from exercise in to the ambient air.”

”Your body is warmer than the water and as the water reaches the temperature it needs to evaporate it leaves the skin taking that energy with it, thus the heat is being transferred to the water. The hot sun is only helping evaporation.”

"When we leaving the swimming pool, the water droplets that remain on the surface of our body are taking significant amounts of heat (molecular kinetic energy) from the surface of our skin. Water has a high heat capacity, in which it takes a lot of heat to force it to evaporate from our skin, by which over the course of the period we are still wet, the water will continue to pull heat from the surface of our body due to the energy gradient created between the warm surface of our body to the cold water, which the temperature difference will alert the peripheral neurons on the surface of our skin, indicating that we are constantly losing heat and we interpret the signal as being 'cold.'"

Experts: Most responders recognized and correctly applied the model of heat of vaporization and described their understanding of this model. 50% of responders took on a nanoscale view, which is much more frequent than either group of student responders. Most responses included a logical flow of ideas. Ex:

"Water has strong intermolecular attractive forces (hydrogen bonding) between H₂O molecules in the liquid state. In the gaseous state the molecules are independent of each other. It takes energy (heat) to break the attractive forces to "free" the independent molecules. The energy needed is different for each substance as indicated by the "heat of vaporization," which for water is a relatively high number. The energy must be provided from some source, in this case the part of your body where the water is. If the body loses heat, its temperature drops."

4. *A baseball is hit into a parking lot and hits a car. Fortunately, the ball just hit the car door and left a dent. If it had hit the window, it surely would have shattered. Why does glass shatter, whereas metal dents?*

This question showed a misconception that many of the introductory and organic chemistry students have. Many students at both levels described metallic bonds as being stronger than covalent bonds, which is not accurate. Many students also discussed atomic arrangement. They described metal as malleable and glass as brittle, with some responses describing the material as a whole, while some described the bonds themselves as malleable and brittle.

Introductory chemistry students: Ex:

"The way the molecules are rearranged are really important. If they park in unusual layers they may not disperse the force like a metal sheet would. Arrangement is important as it plays a big role in materials ability to withstand force."

"The bonds that make up metals tend to be pliable whereas bonds transition metals tend to be more brittle."

"The chemical composition of glass and metal are very different. Metal has stronger chemical bonds which allow it to undertake greater force than glass without breaking. Whereas glass has a weaker chemical bond than metal which allows it to shatter with ease."

Organic chemistry students: Many students describe metallic bonds as more flexible but do not fully describe them as a sea of electrons. Ex:

"Some bonds are more easily broken than others. For example single bonds versus double bonds. Most likely the glass has much weaker bonds which allows it to shatter."

"Metal is a lot more malleable than glass, which means that metal can bend while glass will shatter before changing to a different shape."

"The glass has small crystal lattices that are uniformly align to allow us to see through it. The crystal lattice is extremely uniform and shatters when its hit. Metal usually have larger molecule within it and are molded together to form a strong material."

"Bonds contain specific strengths, and enough energy can break those bonds. For metal compounds, the bonds are less rigid, and are able to flex and bend, meaning that the compound is malleable."

Experts: Most responders correctly recognized, applied, and showed their understanding of the difference between electron arrangement in metallic vs. covalent bonds. Most responders showed a logical flow in their answers. All responders took on a nanoscale view as well as a structural view of electronic and atomic arrangement. No responder showed the misconception that bond strength is responsible for this observation. Ex:

"Electrons are shared freely by atoms within a solid metal (sea of electrons), contributing to the ability of atomic nuclei to reassemble and to undergo severe physical restructuring while still remaining whole and maintaining lots of its physical and electronic properties. Simply put, metals are malleable. Within a glass solid, which is fairly covalent, electronic bonding is highly directional and requires that atomic nuclei remain in precise relative positions. The directionality of the bonding makes glass brittle."

5. *You just picked up a friend from the airport. She pulls out two water bottles from her backpack. One bottle is empty and squished. The other bottle is full of water and not squished. Why?*

The types of responses to this question are similar to those observed for questions 1 and 3.

Introductory chemistry students: All were able to recognize the applicable relationship between pressure and volume and made an attempt to use this relationship to explain the observation of the squished water bottle. However, some students did not accurately describe the relationship between pressure and altitude in the earth's atmosphere. Some students may have never learned how pressure changes with altitude. However, it also shows an absence of voluntarily using observations (a squished bottle that was likely just in an airplane) coupled with a learned model ($PV = nRT$) to fill in the gap of whether pressure is higher or lower at the cruising altitude of a commercial airplane. Students relied more on what they already thought about the connection between altitude and pressure and then tried to apply the learned chemical model after those assumptions. There was no spontaneous questioning or reworking of assumptions and learned models. Ex:

"when she filled the water bottle and placed a cap on it she trapped in air and that bottle has a certain pressure when the plane rises in elevation the pressure increases and caused the bottle to push out the water as for the other bottle I think she must of had no air trapped maybe because she filled it fully."

Organic chemistry students: By contrast, many students were able to recognize and correctly apply the ideal gas law to explain the observation described in the question. Several answers included a logical connection between ideas and provided a basic explanation of the ideal gas model, demonstrating their understanding of the model. This demonstrates that, even though organic students have not specifically studied the ideal gas law during the past year in their organic chemistry course, they are still more adept at applying it and transferring this knowledge. This is most likely due to increased time spent picturing systems of atoms and molecules and increased comfort answering open-ended questions that require application of chemical models to explain observations. Ex:

"Water is an extremely hard liquid to compress, in fact it does not happen very often in nature. As such when the water is taken up into the atmosphere and the air is let out, where the pressure is far less than on the ground, it will not be compressed very much even when at sea level. Air on the other hand has a lot of open space in between the molecules and can thus be very easily compressed."

"According to the kinetic theory of gases/matter theory, liquids are made up of tight-packed molecules that are incompressible while gases are made up of molecules spaced really far apart which are compressible. So the gas molecules in the bag are easier to squish together (and so ARE squished together) than the water molecules."

"Because water is a liquid, when the bottle is squished, the volume the water takes up will not change. On the other hand, because air is a gas, when the bottle is squished, air is able to take up less space, therefore creating the dents."

Experts: Most responders recognized, correctly applied, and showed their understanding of the kinetic theory of gases. Most responses included a logical flow, and about 50% of responses took on a nanoscale view, which is much more frequent than either group of students. Ex:

”The bottle filled with water is not readily compressed like the air-filled bottle. Unlike constant-volume liquids, gases do not have fixed shape or volume. The bottle with air in it was opened at high altitude (lower atmospheric pressure) but presumably ambient (sea level) temperature. The fixed quantity of gas molecules in the bottle at a fixed temperature will have some pressure for the fixed volume of the bottle. At sea level, the atmospheric pressure will overpower the pressure exerted by the gas molecules in the sealed bottle and crush the bottle.”

6. *You buy a hot coffee with sugar. Suppose you drink half of it, and put the rest in the refrigerator to drink as iced coffee later. The next morning, when you take the coffee out of the refrigerator, you notice sugar crystals that were not there before. How can you explain what happened?*

Introductory chemistry students: 50% of students described the sugar as melting in hot coffee. One student among these said ”dissolves or melts” and discussed the sugar then ”freezing when the coffee cools.” One of these students had a logical flow in her or his response, but discussed melting instead of dissolving: Ex:

”The sugar gets to its melting point and starts turning to liquid. As the coffee cools down, the sugar drops back past its melting point and starts ”freezing,” turning from liquid to solid again, hence crystals, the solid form of sugar.”

30% of introductory chemistry students recognized solubility as an applicable principle. Some did not use the correct vocabulary but still explained an accurate picture of dissolution and recrystallization:

”The sugar dissipated in the coffee because of its temp but when placed in the fridge, the coffee cooled down causing the sugar to clump together and form sugar crystals.”

The introductory chemistry students had less logical flow in their answers than the other groups of responders:

”The sugar raises to freezing point of water and a higher temp than normal crystal lattice formation temp will create crystal lattice structures in water and sugar. The sugar and water has a certain interaction.”

Organic chemistry students: Most students recognized the temperature dependence of solubility as the applicable principle. Organic students gain lots of experience with recrystallization in the organic chemistry laboratory. Perhaps the repeated kinesthetic learning

and applied use of the model of temperature dependence on solubility prepared them well to answer this question. Many students mentioned recrystallization in their answers:

”Things dissolve better in hot substances and less in cold substances. When the drink started to become cold, crystals began to recrystallize out of the drink. That’s just because in hot substances, the solvent can hold more solute. When cold, the solvent holds less solute.”

”Sugar was dissolved in the coffee because the coffee was hot! However when it cooled down, it caused the sugars to reform. This is known as recrystallization!”

Many answers included a logical flow and connection of ideas. One student even connected their response with what they’ve learned about Gibbs free energy and how temperature affects equilibrium:

”As the coffee heats the sugar molecules can move faster so their bonds can break more easily so it will have a higher solubility at a higher temperature. Maybe when sugar dissolves it is an endergonic reaction so heat causes the equilibrium to shift to the right.”

Experts: All responders recognized and correctly applied the temperature dependence of solubility and showed a logical flow of connected ideas. Most responders also demonstrated their understanding of this model in their responses and took on a nanoscale view of the system, while a few responses included a structural view as well. Experts demonstrated a deeper description of the system. Similarly to question 1, experts described competing interactions of the sugar bonding with itself vs interacting with the water molecules. Ex:

”Temperature affects solubility. At higher temperature there is more thermal energy to keep the sugar crystals dissolved. At lower temperature the lower energy configuration of crystal sugar favored. At high temp the water is bombarding the sugar crystals more, favoring the entropy of having the sugar sample many different microenvironments of being dissolved, whereas at low temp the crystal structure energy gain dominates.”

7. Why do you need to recharge the battery on your cell phone? What happens inside the battery when you do this?

This question proved challenging for both introductory and organic chemistry students. The system in this question (the cell phone battery) is more complex than the systems in the questions that elicited a broader range of responses. The complexity of the system also makes it more difficult for the student to directly observe the charging of the cell phone battery. There’s less tangible evidence for the observation described in the question. For example, the squishing of a water bottle (question 5) is something a student can see and touch. Seeing the reduced volume inside the water bottle may make it easier for students to then picture

the molecular system causing this volume decrease. The only observation a student has that a cell phone has charged is what is displayed on the screen. A student cannot easily interact with the circuits inside the cell phone in which electrons are moving. This may make it more difficult for students to map the nanoscale system onto the macroscale object.

This complexity and farther removal from the system in question made responses from both groups of students somewhat weak relative to responses to other questions using simpler and more easily perceivable systems. This manifested as an offset in overall scores on the various categories tagged (see Figures 8.1, 8.2, 8.3, 8.4, 8.5, 8.6, 8.7, and 8.8). However, there is still a distinction between introductory students and organic students. The distinction observed is similar to that observed in questions 1, 3, 5, and 6.

Introductory chemistry students: These students recognized the applicability of current and electron flow, but did not include much detail beyond this: Ex:

”With my superficial understanding I would say that charging the phone basically collects electrons and when you use your phone the circuit drives the flow of electrons around the circuit board.”

”Using the phone requires energy to release the heat caused by the constant use of its internal machinery. When you charge your phone it is replacing the energy that the phone has lost by adding electrical energy to recharge the battery.”

Organic chemistry students: Some were at a similar level of understanding as the introductory chemistry students:

”Over time the electrons lose charge to the environment and dont say in the system. Charging replenishes the charges.”

Some organic students went so far as to recognize the redox reaction happening in a battery, and that electron flow restores potential energy that the cell phone recently used:

”Charging up battery stores potential energy within the battery. As we use the battery the potential energy is used up as it pushes electrons through the wire. Therefore recharging the battery will store up the potential energy again to do the same thing.”

Experts: All responders recognized the applicable model of putting energy in to reverse the spontaneous redox reaction that takes place when the battery powers the cell phone. Most responders correctly applied this model, demonstrated their understanding, showed a logical flow of ideas, and took on a nanoscale view. Experts took on a deeper analysis of why both fundamentally and practically recharging is necessary - why a battery even runs out in the first place. This level was not reached by the student responders. Ex:

”When the battery is being used, an electrochemical process is occurring that is limited by the quantity of its initial reactants. When the battery is charged, that rxn is run in reverse, replenishing the supply of reactants. Charging is necessary to make the battery reusable.”

9. *How is it possible to eat every day and not gain weight? Only about 15% of the mass from the food you consume is eliminated through the bladder and large intestine. Where does the other 85% go?*

In order to answer this question well, responders must first recognize that, in order for you to not gain weight, the mass you consume must leave your body. Students must recognize the fundamental principle of conservation of mass and also picture the body as a system for which $\text{mass}_{in} = \text{mass}_{out}$ if weight change = 0. Most students do not seem to be approaching the problem as described above. Students are instead describing the food we consume as calories that get burned off from doing activities. Some students state that the consumed food is turned into energy and leaves the body as heat. This suggests a memorized response from students and perhaps a lack of deeper thought toward the concept of conservation of mass. Do the students really believe the mass is converted to pure energy via Einstein’s $E = mc^2$? Or have they not thought about the implications of suggesting that the body is capable of converting mass purely into energy? I suggest the latter.

Introductory chemistry students: 80% showed the misconception that the mass we consume as food gets converted into energy. These students did not recognize the detail that the energy comes from change in bond enthalpies between bonds broken and bonds formed and not from conversion of mass to energy. Ex:

”You would not gain weight if you burned off or used all the calories you consumed from the food it’s only when unused calories turn to fat which causes weight gain.”

Organic chemistry students: 71% of these students showed the same misconception described above:

”Everything we do uses energy, therefore the food we break down in our body are mostly turned into energy.”

Some, though the minority, correctly applied the conservation of mass and simplified combustion reaction to represent metabolism:

”As it turns out the majority of waste is exhaled through the lungs. Hydrocarbons are combusted in cells for energy and the resulting waste is either transported to the excretory system or exhaled as carbon dioxide.”

Experts: About 65% of responders recognized the full extent of conservation of mass as well as metabolic reactions necessary to answer this question completely, and the same fraction

correctly applied these models. Most demonstrated their understanding of these models. About 50% took on a nanoscale view, and just under 20% took on a structural view. Only about 15% showed the misconception described above. Ex:

”Most of the absorbed food is used as fuel to provide energy. In the reactions to provide energy, most of the C and H and O mass of the food is converted into CO_2 and H_2O . The molecules (and therefore the mass) of carbon dioxide and water vapor are constantly exhaled as gases.”

10. *Candy with a coating of malic acid is sour. Suppose you want to make the candy super sour. How would you go about choosing a different coating?*

Responses to this question were especially difficult to evaluate. The models I expected responders to use are those of pKa or Ka (acid strength aka acidity) and the distinct pH (H^+ concentration) for the same total acid concentration. Many responses discussed acidity (described by pKa) and pH, but did not make clear if the responder understood the distinction between these two values. Confusion over the difference between pKa and pH shows a common misconception in previous work showing that some chemistry students think that the concentration and strength of an acid are the same thing [39].

Some responses were reasonable but did not call upon pKa or pH, such as one expert’s response to increase the surface area of the candy by adding pits and ridges (thereby increasing the effective concentration). It will be discussed further in the following sections why this question, as it was worded, is not effective at measuring transfer. However, I suggest that a rewording and clarification of this question would substantially improve its utility as a transfer question, such as by emphasizing that the responder must choose a different compound for the coating and may not change the effective concentration.

Introductory chemistry students: Some students discussed pH only but did not discuss pKa or Ka. It’s possible that these students have not yet developed a full understanding of weak acid dissociation constants, so it may be unreasonable to expect them to consider the relationship among concentration, pKa or Ka, and pH. Some students discussed acidity, but described it as being measured by pH rather than pKa and concentration, suggesting a lack of understanding of the distinction between pH and pKa. Ex:

”Finding coatings with a lower pH level will give it that bitter sour taste but to a certain extent. Too much acidity will become dangerous.”

Other introductory chemistry students considered pH, but applied pH incorrectly. Introductory chemistry students overall recognized the applicability of acid-base chemistry, but did not correctly apply their knowledge of acid-base chemistry. Ex:

”I would look for an acid with a pH that is higher than malic acid yet safe to consume.”

Organic chemistry students: Some students had the same type of confusion as the introductory chemistry students by describing pH as a measure of acidity rather than pKa:

”If something has a low pH it will become sour. If you want a more sour candy, choose an acid that is more acidic than malic. (Just not too acidic, dont put HCl on it).”

Other students answered with both pH and pKa and demonstrated their understanding of the distinction between these two values:

”Higher concentrations of weak acids, as well as stronger acids, make for more acidic protons in solution. This acidic protons are perceived as sour, so more protons in solution will be more sour.”

”The sour taste of acids comes from free H^+ ions, detected by our taste buds. To make a super sour candy, you would want an acid that decomposes readily in the mouth, so create H^+ ions.”

This student took a different approach, making no assumptions and providing a generalized answer, showing general scientific thinking:

”Different functional groups exhibit different properties. Whichever functional group is responsible for the sour taste should be added.”

Overall, more of the organic students moved farther through the process of recognizing, applying, and correctly applying their knowledge of acid-base chemistry than Introductory students. More organic students also showed a logical connection of ideas in their answers and pictured molecules on the nanoscale rather than only on the macroscale.

Experts: Most responses recognize the applicable principle of acidity. Just over 55% of responses explicitly showed understanding of pKa and pH values. 50% of responders correctly applied pKa and pH to answer this question accurately. Most responders used a logical flow of ideas and took on a nanoscale view, while 50% took on a structural view as well. Just over 30% of responses showed ambiguity in whether or not the responder understood the distinction between pKa or Ka and pH. Experts did also show a deeper analysis and other ways of approaching this question in addition to simple pH and pKa. Ex:

”The sourness of the malic acid is a result of its acidity, or pH. A potentially more sour coating would have a lower pH.”

”I would probably investigate other edible, noncaustic acids that have slightly lower pKa’s than malic acid as potential coatings. It is likely the acidic property of the malic acid that causes the taste buds to sense ”sourness”; I would expect that a more acidic compound would make the candy taste more sour.”

”Taste and smell is triggered by molecules making their way into receptors on your tongue and in your nose. The better the fit for that receptor, the stronger the response. I’d look at what kind of molecules fit in your sour receptors, and try to find something that was the best possible fit in terms of structure and polarity.”

11. *In order to make bread dough, fermentation produces CO_2 , causing the dough to rise. The CO_2 also lowers the pH of the dough. However, the chemical species in other ingredients such as milk can mitigate this pH change. Milk is slightly acidic with a pH around 6.6. How could it prevent the CO_2 from making the dough more acidic?*

Introductory chemistry students: Most students did not consider the detail given in the question that an acidic solution can prevent something from becoming acidic. Students called upon their knowledge of acid-base chemistry, but not in a way that could fully explain the observation in the question. The absence of acknowledgment of the inconsistency of their knowledge with the observation is also notable. This sounds more like regurgitation than true understanding. Ex:

”We basically have proton donors and proton acceptors and if you can reduce enough of the H^+ generated by CO_2 you will have a less acidic solution. Milk will do that for you.”

One introductory chemistry student claimed that 6.6 is a basic pH:

”By adding milk to the mixture, the lower pH milk reduces the overall molarity of the entire mixture. Additionally, a pH of 6.6 corresponds to a basic solution, not a slightly acidic solution. Thusly, by adding a basic solution to acidic one, it brings the over acidity closer to a pH of 7.0 or neutral.”

The most logical idea presented by an introductory chemistry student:

”The CO_2 may not be strong enough to lower the pH by a large amount or the milk helps to neutralize the acid in the bread.”

Organic chemistry students: Many responders recognized the presence of a buffer that prevents an already acidic solution from becoming more acidic. Some responses may be regurgitation, but others express some understanding of buffers. While introductory students seem to barely make it to the recognition of applicable chemical principles, several organic students demonstrate recognition, understanding (some), application, and correct application. Ex:

”Milk creates a buffer against CO_2 to prevent its decrease in pH. CO_2 has to neutralize the milk first before it can reduce the pH of the system.”

Experts: All experts recognized and most correctly applied the model of buffers to answer this question. Most also demonstrated understanding of buffers in their response. A majority of responses included a logical flow of ideas, and about 50% used a nanoscale and structural view of the system. Ex:

”The milk probably contains several compounds or proteins with several functional groups that are have a weak acid or weak base form. At pH 6.6 some of the functional groups will still be in their weak base form. An organic acid in milk could have a pKa of about 5. That means that at pH 5 it would have about half its molecules in the acid form and half in the base form. At pH 6.6 more of the molecules would be in the base form. If H^+ is added to the mixture from fermentation, the H^+ would attach to the weak base form making it into the weak acid form. This would change the pH to a little lower but not as much as if just strong acid was added, since a weak acid is only slightly ionized to H^+ and $[H^+]$ is the term that pH is calculated from, not $[RCO_2H]$. $pH = -\log [H^+]$ ”

8.4 Questions eliciting expected response range

Overall, the transfer questions that can best distinguish between different levels of chemistry background and expertise and therefore most effectively measure knowledge transfer in chemistry are those that can be at least partly answered with simple recognition of the underlying chemical principle and straightforward application of that principle to explain the everyday observation. Finding the actual answer is not especially tricky and may in fact seem obvious to an expert. This way, the range of depth and detail shows up after most students (at any level) have recognized the underlying chemical principle and applied it in some way. Putting up too high of a barrier to recognition and application may leave all students unable to even begin to climb the wall.

Specifically, questions 1, 3, 5, 6, and 11 showed the best spread of response while also allowing responders of all levels to demonstrate their ability to transfer chemistry knowledge to common observations outside the classroom.

These questions work to distinguish between expertise levels because they are both accessible and easy to understand while allowing for a range of sophistication of responses. There is more to the answer than simple right and wrong. These transfer questions share the following four attributes:

1. Simple language, little to no chemistry vocabulary or jargon.
2. Simple system
3. Observation/evidence to be explained is easy to directly observe/perceive

4. Unlikely to elicit misconceptions

These four attributes describe the transfer questions used in this work that showed the most expected range of responses correlating with the three different levels of expertise of responders. I suggest that questions 1, 3, 5, 6, and 11, all of which share the four attributes described above, coupled with the detailed evaluation method described in Section 7.4, can be used widely by researchers and instructors for measurements of knowledge transfer at various levels of education and expertise in chemistry. I also suggest that additional transfer questions having these four attributes can be written and used for a similar purpose. These four attributes may serve as guidelines for designing and writing more questions and tools to measure transfer in chemistry education.

8.5 Questions eliciting unexpected response range

Questions that did not elicit the expected range of responses as expertise level was varied among responders included more advanced questions that described more complex systems and sometimes had common misconceptions tied to them.

Some of the questions effectively found misconceptions that introductory and organic chemistry students, and even a few of the experts share. Open-ended questions about everyday situations asking for written responses, similar in style to the questions used in this dissertation work, have been used in previous work that specifically studied misconceptions in chemistry [21]. Previous work has shown that some misconceptions are resistant to change despite further education in chemistry [28]. While misconceptions are interesting to discover on their own, they don't seem to be useful in distinguishing between students by level of expertise. When all students fall into the same trap or apply the same misconception, they all get stuck at the same spot of being unable to effectively connect their answer to the everyday observation in the question. This limits the spread of depth and detail of responses.

Some misconception questions were deliberately designed and included by the researchers with the hypothesis that they would push students to really think analytically rather than use memorized responses. While this is true, it seemed that only the expert level responders were able to think analytically enough to avoid the misconception associated with the question. These questions may be too challenging for lower-level undergraduate students. I suggest that these misconception questions are useful and sensitive tools for measuring transfer in advanced students and experts.

In summary, questions that are not useful at measuring transfer in lower level undergraduate students share the following three attributes:

1. Complex system
2. Observation/evidence to be explained is difficult to directly observe/perceive

3. Likely to elicit misconceptions

Specifically, questions 4, 7, 9, and 10 showed the least expected range of responses as expertise level varied. Questions 4, 7, and 9 can be described with the three attributes listed above. Question 4 elicited a misconception about bond strength and may have been too advanced for introductory chemistry students who may not have learned about metallic bonding. Even for students who have learned about metallic bonding, previous work has shown that student misconceptions related to bonding are especially resistant to change despite further education in chemistry [28].

Question 7 described a more complex system that is also difficult to observe directly.

Question 9 also described a complex system that is difficult to observe directly. It also elicited a common misconception about converting food into energy in the body. A similar question shows up in the literature on misconceptions in chemistry and biology. Rather than asking where the mass of the food we consume goes, the misconception literature has used questions about where plants get most of their mass. The common misconception among biology students is that plants get their mass from the soil, when, in fact, they get their mass from the CO_2 in the atmosphere [7]. While the question used in this dissertation work asks more about where mass goes after it's "used" by the body, and the misconception literature asks where mass comes from to create plant matter, both misconceptions are rooted in students' thinking of gas as having no substantial mass. Previous work has also shown evidence that many chemistry students hold the misconception that gas has little to no mass [39]. While misconceptions are resistant to change using traditional course materials and practices in chemistry, previous work has suggested that misconceptions can be remedied using lesson plans that specifically target known misconceptions [39].

It is worth noting that, despite the complexity of the system and the misconception shown by many responders in question 9, the responses did show the expected correlation between response depth and detail and expertise level in all categories scored. As described in Section 8.3, the complexity of the system and common misconception made responses from both groups of students somewhat weak relative to responses to other questions using simpler systems without common misconceptions. This manifested as an offset in overall scores on the various categories tagged (see Figures 8.1, 8.2, 8.3, 8.4, 8.5, 8.6, 8.7, and 8.8). Despite showing the expected correlation, I maintain that this question is not effective at measuring transfer in the undergraduate student responders. Because such a large percentage of students showed the misconception, most students did not have the opportunity to show their ability to transfer knowledge. While analysis of responses included looking for what responders do and don't know, a sufficient demonstration of what the responder does know is necessary in order to measure transfer. I suggest that this question and other like it may be more useful for measuring transfer in advanced undergraduates and expert level chemists.

Questions 10 elicited the misconception seen in previous work that the concentration and strength of an acid are the same thing [39]. Apart from eliciting this misconception in a minority of responses, question 10 does not share the first two attributes listed above, but has been categorized as less useful for transfer measurement due to its being more open-

ended and less specific than the rest of the questions. As described in Section 8.3, question 10 did not guide the responders sufficiently to elicit answers that clarified the responder's understanding of the distinction between pH and pKa. Responses were therefore ambiguous and difficult to evaluate. Re-wording the question to focus the responder on finding a new compound without changing concentration may decrease the likelihood of finding this ambiguity in response:

Candy with a coating of malic acid is sour. Suppose you want to make the candy super sour. How would you choose a different substance for the coating that can be applied in the same quantity as the malic acid?

This type of rewording focuses students in on changing the nature of the coating (pKa value) rather than the concentration of the coating (pH).

8.6 What makes a more or less useful and sensitive transfer question?

As described in Section 7.2, the useful transfer questions in this work would be described as far transfer tasks according to Sasson and Dori's three-attribute transfer skills framework. This makes sense, since the questions are designed to measure transfer over a range of expertise levels in chemistry. The questions are accessible and at least partially do-able by Introductory chemistry students yet challenging enough to elicit deeper and more detailed responses from more advanced undergraduate students and field experts. More specifically, useful transfer questions have a large task distance, meaning they may be very different from the typical questions students practice answering as part of their coursework. Interdisciplinarity is not necessary to answer most of these questions, but many of the useful transfer questions do allow responders to include interdisciplinarity in their responses. This opportunity for interdisciplinarity is another piece that makes these questions able to measure transfer in a range of expertise levels in chemistry. Skillset is relatively high for most useful questions because responders are required to apply chemical models on their own by recognizing the applicable chemical model and making the connection between the nanoscale chemical model and the macroscale observation.

As described in the Section 8.4, the most useful transfer questions contained the following four attributes:

1. Simple language, little to no chemistry vocabulary or jargon.
2. Simple system

3. Observation/evidence to be explained is easy to directly observe/perceive
4. Unlikely to elicit misconceptions

As described in Section 8.5, questions that elicit misconceptions are useful in studies focusing on misconceptions and how instruction may be improved to decrease misconception prevalence. However, questions eliciting misconceptions did not serve the purposes of this dissertation work.

These findings can be summarized in a model similar to the threshold model of content knowledge transfer [32]. Figure 8.9 shows the model proposed by this dissertation work to summarize and describe the minimum levels of expertise capable of showing transfer when different levels of complexity of question are asked as transfer tasks. The first step shown in the plot in Figure 8.9 shows the type of question in which introductory chemistry students are capable of showing transfer. The next step shows the type of question in which organic students, and likely other intermediate and advanced level undergraduates, are capable of showing transfer. The highest step describes the type of complex transfer question in which only field experts show a significant amount of knowledge transfer. The x-axis, while showing the specific levels of students and experts measured in this work may also show more continuously an increase in content knowledge as well as time on task and practice thinking like a chemist as expertise level increases. The y-axis shows an increase in the progress the responder makes in his or her response to the transfer question along the transfer pathway, frequency of logical flow, and frequency of nanoscale view used by the responder (the three categories used to tag and evaluate transfer question responses).

Each step in Figure 8.9 is larger than the previous one to show the increase in content knowledge, time on task, and progress along transfer question evaluation categories as expertise level advances from introductory chemistry to organic chemistry to expert level. Specifically, the progress made from organic chemistry to chemistry expert is more substantial than the progress made from introductory to organic chemistry, which is more substantial than the progress made from no chemistry background to introductory chemistry.

This model may be used by researchers and educators writing additional transfer tasks and questions similar to or different from the questions used in this work. By finding where on the plot in Figure 8.9 the transfer task falls, one can have a reference point for what level(s) of students or practitioners can be expected to show transfer through this task.

As important as the question itself is also the evaluation method or grading criteria used for the response. I suggest using a similar method of evaluation as described in Section 7.4 of this dissertation to ensure that researchers and educators are indeed finding and identifying the knowledge transfer evident in their responses.

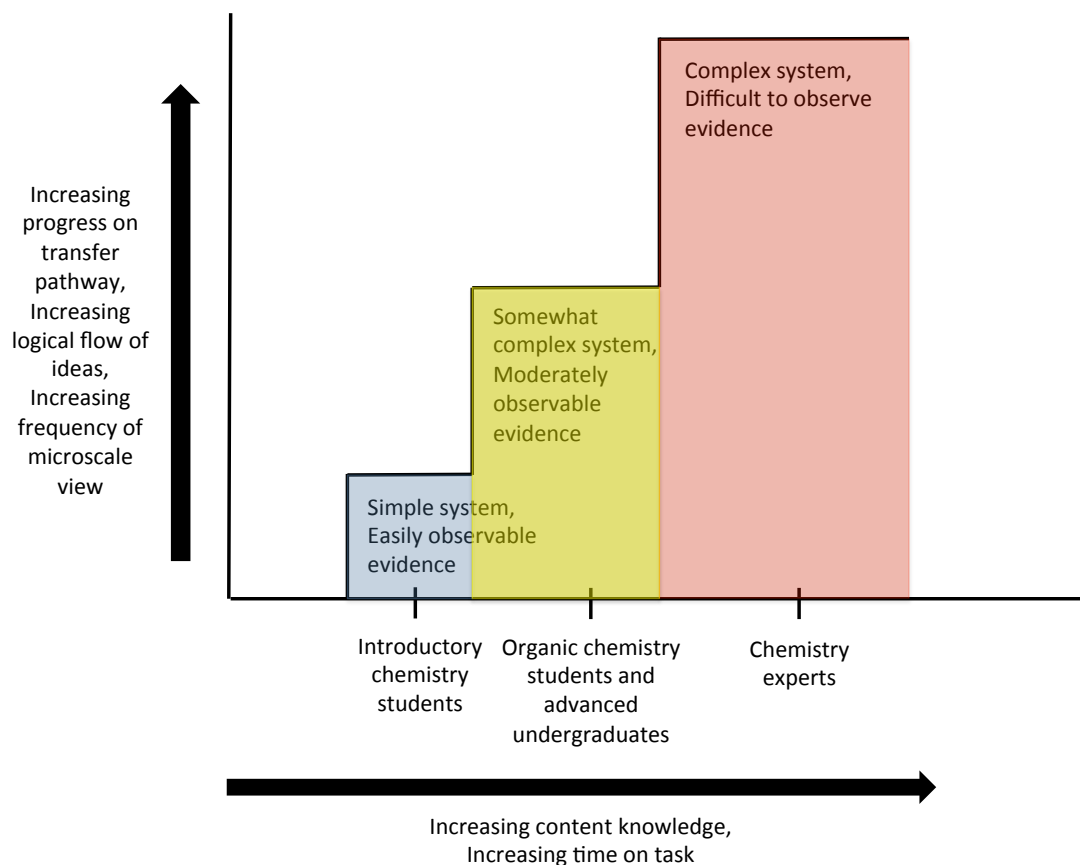

Figure 8.9: Model of transfer question attributes. This model summarizes and describes the minimum levels of expertise capable of showing transfer when different levels of complexity of question are asked as transfer tasks. The first step shown in the plot shows the type of question in which Introductory chemistry students are capable of showing transfer. The next step shows the type of question in which Organic students, and likely other intermediate and advanced level undergraduates, are capable of showing transfer. The highest step describes the type of complex transfer question in which only field experts show a significant amount of knowledge transfer. The x-axis, while showing the specific levels of students and experts measured in this work may also show more continuously an increase in content knowledge as well as time on task and practice thinking like a chemist as expertise level increases. The y-axis shows an increase in the progress the responder makes in his or her response to the transfer question along the transfer pathway, frequency of logical flow, and frequency of nanoscale view used by the responder.

8.7 Summary

Detailed analysis of responses to each transfer question showed that some questions were more effective at distinguishing between expertise levels while also allowing responders of all levels to show knowledge transfer. Simpler questions that are more accessible to students of introductory chemistry proved the most useful at eliciting a range of responses that correlate with expertise level while still showing some degree of transfer in all levels of responders. More challenging questions with complex systems and common misconceptions are too advanced for lower level undergraduates to show knowledge transfer, but may be useful to show transfer in advanced undergraduates and experts.

Chapter 9

Conclusion and Future Work

9.1 Conclusion

A set of transfer task questions has been developed that is capable of showing transfer in students ranging from introductory chemistry level to expert level chemistry educators and practitioners. A system of analysis has also been developed to sensitively evaluate responses to these transfer questions. Using easily accessible and open-ended transfer questions and evaluating responses analytically and carefully gives us a set of transfer measurement tools that may be used in a wide variety of transfer research as well as classroom settings.

In addition to the development of these useful questions, the questions have been analyzed to determine the following four attributes that make these questions useful transfer measurement tools:

1. Simple language, little to no chemistry vocabulary or jargon.
2. Simple system
3. Observation/evidence to be explained is easy to directly observe/perceive
4. Unlikely to elicit misconceptions

I suggest that more transfer tasks and questions for undergraduate chemistry students may be developed with these attributes in mind. I also suggest that questions with attributes more difficult, advanced, and complex than the four listed above may also be used as transfer tasks for more advanced undergraduates and expert-level chemistry practitioners.

9.2 How can these findings be used by researchers and educators?

Transfer questions and response evaluation methods capable of distinguishing degrees of transfer between chemistry students at different levels as well as field experts may be useful by both researchers in chemistry education and chemistry teachers at the postsecondary level.

Using these questions and the associated methods of evaluation described in Section 7.4 of this dissertation as part of the curriculum for an undergraduate level chemistry course gives students the opportunity to practice knowledge transfer. It also communicates to students that part of the learning goals for the course are to be able to apply their knowledge to experiences outside the classroom.

In addition to being part of the normal curriculum for an undergraduate chemistry course, transfer questions and associated evaluation methods may also be used by a postsecondary institution to evaluate student learning outcomes and goals for its courses. The work presented in this dissertation provides guidance on the level of depth and detail of response to be expected by students at the end of an introductory, freshman level chemistry course and at the end of an organic, sophomore level chemistry course.

9.3 Future work

The work described in this dissertation used a limited number of students (27) and experts (6) providing responses to the transfer questions. Repeating this study with a significantly larger number of responders would provide more statistically significant data to help corroborate and expand upon the findings in this work.

Analyzing and assessing responses to these and similar transfer questions by the same set of students at the beginning and end of an undergraduate chemistry course would further evaluate the utility of these questions in measuring change in knowledge transfer skills brought about by a specific chemistry course.

In addition to work that would further evaluate these transfer measurement tools, it is my hope that these questions and/or others written with the guidance of the findings in this dissertation work will ultimately be used as transfer measurement tools in future research on transfer itself contributing to the existing body of work and moving toward a deeper and more cohesive understanding of knowledge transfer.

Bibliography

- [1] P. N. Arendt and S. R. Foltyn. “Biaxially textured IBAD MgO templates for YBCO coated conductors”. In: *MRS Bulletin* 29.8 (2004), p. 543.
- [2] Patricia Armstrong. *Bloom’s Taxonomy*. URL: <https://cft.vanderbilt.edu/guides-sub-pages/blooms-taxonomy/> (visited on 07/11/2016).
- [3] C. Baldasseroni et al. “Heat transfer simulation and thermal measurements of microfabricated x ray transparent heater stages”. In: *Review of Scientific Instruments* 82.093904 (2011).
- [4] John D. Bransford and Daniel L. Schwartz. “Rethinking Transfer: A Simple Proposal With Multiple Implications”. In: *Review of Research in Education* 24.3 (2001), pp. 61–100.
- [5] Benjamin Burack and Donald Moose. “Effect of Knowing the Principle Basic to Solution of a Problem”. In: *Journal of Educational Research* 50.3 (1956), pp. 203–208.
- [6] J. Chang. *Marvell Nanofabrication Laboratory Manual: Chapter 8.52, Flexus Thin Film Stress Measurement*. Marvell Nanofabrication Laboratory, 2004.
- [7] John D. Coley and Kimberly Tanner. “Relations between Intuitive Biological Thinking and Biological Misconceptions in Biology Majors and Nonmajors”. In: *CBE - Life Sciences Education* 14.8 (2014), pp. 1–19.
- [8] David W. Cooke et al. “Calorimetry of Epitaxial Thin Films”. In: *Review of Scientific Instruments* 82.023908 (2011).
- [9] David W. Cooke et al. “Thermodynamic Measurements of FeRh Alloys”. In: *Physical Review Letters* 109.255901 (2012).
- [10] D.W. Cooke. “Strain Fields of a Buckled Silicon Nitride Membrane”. In: *APS March Meeting* (2010).
- [11] Stephen M. Cormier and Joseph D. Hagman. *Transfer of Learning: Contemporary Research and Applications*. 1250 Sixth Avenue, San Diego, CA 92101: Academic Press, Inc., 1987.
- [12] *CRC Handbook of Chemistry and Physics*. Boca Raton, FL: CRC Press, 2015.
- [13] D.W. Denlinger et al. “Thin film microcalorimeter for heat capacity measurements from 1.5 to 800 K”. In: *Review of Scientific Instruments* 65.4 (1994).

- [14] Douglas K. Detterman and Robert J. Sternberg. *Transfer on Trial: Intelligence, Cognition, and Instruction*. 355 Chestnut Street, Norwood, NJ 07648: Ablex Publishing Corporation, 1993.
- [15] Yehudit Judy Dori and Irit Sasson. “A three-attribute transfer skills framework - part I: establishing the model and its relation to chemical education”. In: *Chemistry Education Research and Practice* 14 (2013), pp. 363–375.
- [16] D.K. Finnemore et al. “Coated conductor development: An assessment”. In: *Physica C* 320.1-2 (1999), pp. 1–8.
- [17] Mary L. Gick and Keith J. Holyoak. “Analogical problem solving”. In: *Cognitive Psychology* 12.3 (1980), pp. 306–355.
- [18] Mary L. Gick and Keith J. Holyoak. “Schema induction and analogical transfer”. In: *Cognitive Psychology* 15.1 (1983), pp. 1–38.
- [19] J.R. Groves et al. “Dual Ion Assist Beam Processing of Magnesium Oxide Template Layers for 2nd Generation Coated Conductors”. In: *IEEE Transactions on Applied Superconductivity* 17.2 (2007).
- [20] J.R. Groves et al. “Ion-beam Texturing At Nucleation: Investigation of the Fundamental Mechanism of Biaxial Texture Development In Ion Beam Assisted Deposition and Applications”. In: *Thesis: (Ph.D) Stanford University* (2010).
- [21] Derya Kaltakci Gurel, Ali Eryilmaz, and Lilian Christie McDermott. “A Review and Comparison of Diagnostic Instruments to Identify Students’ Misconceptions in Science”. In: *Eurasia Journal of Mathematics, Science and Technology Education* 11.5 (2015), pp. 989–1008.
- [22] H.M.Soliman and A.F.Waheed. “Effect of Differential Thermal Expansion Coefficient on Stresses Generated in Coating”. In: *Journal of Materials Sciences and Technology* 15.5 (1999), p. 457.
- [23] Lab group of Jeffrey Bokor. *Marvell Nanofabrication Laboratory Manual: Chapter 8.12, DI AFM Nanoscope Dimension 3100: Atomic Force Microscope*. Marvell Nnanofabrication Laboratory, 2015.
- [24] “Magnesium oxide (MgO) crystal structure, lattice parameters, thermal expansion”. In: *II-VI and I-VII Compounds; Semimagnetic Compounds*. Ed. by O. Madelung, U. Rössler, and M. Schulz. Berlin, Heidelberg: Springer Berlin Heidelberg, 1999, pp. 1–6.
- [25] “Magnesium oxide (MgO) Young’s, shear and bulk moduli, Poisson’s ratio”. In: *II-VI and I-VII Compounds; Semimagnetic Compounds*. Ed. by O. Madelung, U. Rössler, and M. Schulz. Springer Berlin Heidelberg, 1999, pp. 1–3.
- [26] R.E. Mayer and M.C. Wittrock. “Problem Solving Transfer”. In: *Handbook of educational psychology*. Macmillan, 1996.
- [27] Evelyn L. Mudge. “Transfer of training in chemistry”. In: *Digests of Unpublished Investigations* 22.5 (1938), pp. 259–260.

- [28] Gayle Nicoll. “A report of undergraduates’ bonding misconceptions”. In: *International Journal of Science Education* 23.7 (2001), pp. 707–730.
- [29] Yasumasa Okada and Yozo Tokumaru. “Precise determination of lattice parameter and thermal expansion coefficient of silicon between 300 and 1500 K”. In: *Journal of Applied Physics* 56.2 (1984), pp. 314–320.
- [30] O. Polat et al. “Direct growth of LaMnO₃ cap buffer layers on ion-beam assisted deposition MgO for simplified template-based YBa₂Cu₃O_{7- δ} -coated conductors”. In: *Journal of Materials Research* 23.11 (2008).
- [31] D.R. Queen. “The Specific Heat of Pure and Hydrogenated Amorphous Silicon”. In: *Thesis: (Ph.D) University of California Berkeley* (2011).
- [32] Troy D. Sadler and Samantha R. Fowler. “A threshold model of content knowledge transfer for socioscientific argumentation”. In: *Science Education* 90.6 (2006), pp. 986–1004.
- [33] Irit Sasson and Yehudit Judy Dori. “A three-attribute transfer skills framework - part II: applying and assessing the model in science education”. In: *Chemistry Education Research and Practice* 16 (2015), pp. 154–167.
- [34] Jonathan T. Shemwell, Catherine C. Chase, and Daniel L. Schwarz. “Seeking the General Explanation: A Test of Inductive Activities for Learning and Transfer”. In: *Journal of Research in Science Teaching* 52.1 (2015), pp. 58–83.
- [35] E.L. Thorndike and R.S. Woodworth. “The influence of improvement in one mental function upon the efficiency of other functions”. In: *Psychological Review* 8 (1901), pp. 247–261.
- [36] Inc. Veeco Instruments. *IBS 250 Power Supply Technical Manual*. Veeco Instruments, Inc., 2002.
- [37] C. P. Wang et al. “Deposition of in plane textured MgO on amorphous SiN substrates by ion beam assisted deposition and comparisons with ion beam assisted deposited yttria stabilized zirconia”. In: *Applied Physics Letters* 71.20 (1997), pp. 2955–2957.
- [38] C.P. Wang. “Ion-beam-induced texturing in oxide thin films and its applications”. In: *Thesis: (Ph.D) Stanford University* (1999).
- [39] Buket Yakmaci-Guzel. “Preservice chemistry teachers in action: an evaluation of attempts for changing high school students’ chemistry misconceptions into more scientific conceptions”. In: *Chemistry Education Research and Practice* 14 (2013), pp. 95–104.