

# Lawrence Berkeley National Laboratory

## Lawrence Berkeley National Laboratory

### **Title**

Theta13 Neutrino Experiment at the Diablo Canyon Power Plant, LBNL  
Engineering Summary Report

### **Permalink**

<https://escholarship.org/uc/item/3v0686rb>

### **Author**

Oshatz, Daryl

### **Publication Date**

2004-03-12

$\theta_{13}$

Neutrino Experiment at the Diablo Canyon Power Plant

LBNL Engineering Summary Report\*

March 12, 2004

Daryl Oshatz

\*This work was supported by the Director, Office of Science, Office of High Energy and Nuclear Physics, Division of High Energy Physics, U.S. Department of Energy under contract number DE-AC03-76SF00098

Table of Contents

<b>1.0</b>	<b>Overview</b>	<b>3</b>
<b>2.0</b>	<b>Detector Rooms</b>	<b>3</b>
2.1	Detector Room Concept	3
2.2	Access and Interface with Tunnel	5
2.3	Radiation Shielding and Support Structure	5
2.3.1	Shielding Description	6
2.3.2	Support Structure Description	6
2.3.3	Shielding and Support Structure Cost Estimate	7
2.3.4	Access Inside Shielded Bunker	7
2.4	Muon Detector System	8
2.5	Magnetic Compensating Coils	9
2.6	Infrastructure and Utilities	9
2.6.1	Heating Ventilation and Air Conditioning	9
2.6.1.1	Radon Gas Requirements	10
2.6.1.2	Temperature, Humidity, and Cleanliness Requirements	10
2.6.1.3	Personnel Occupancy Requirements	10
2.6.1.4	HVAC Budgetary Cost Estimate	10
2.6.2	Overhead Crane and Material Handling	11
2.7	Underground Storage Tank Design	11
2.7.1	Summary of Relevant UST Requirements	11
2.7.2	UST System Design	13
<b>3.0</b>	<b>Detectors</b>	<b>16</b>
3.1	Overall Detector Concept	16
3.2	Mobile Detector Systems	17
3.2.1	PMT Electronics Racks and Cables	18
3.2.2	Oil Overflow Tanks	18
3.2.2.1	Scintillator Volume Overflow	18
3.2.2.2	Buffer Volume Overflow	18
3.3	Outer Tank (Detector Outer Tank)	18
3.3.1	Outer Tank Mechanical Design and Fabrication	19
3.3.1.1	Outer Tank Draft Fabrication Specification	19
3.3.2	Outer Tank Procurement and Cost Estimate	20
3.3.3	Locomotion System and Roller Cost Estimate	21
3.4	Scintillator Vessel (Acrylic Vessel)	21
3.4.1	Mechanical Design and Fabrication	22
3.4.1.1	Draft Fabrication Specification	23
3.4.2	Budgetary Cost Estimate	23
3.4.3	Support Concept	24
3.4.4	Stress and Deflection Analysis	25
3.4.4.1	Vessel Weight and Buoyancy	25
3.4.5	Finite Element Analysis (FEA) Model	26
3.4.5.1	Structural Loading Conditions	28
3.4.5.2	FEA Static Results	28
3.4.5.3	FEA Seismic Results	29
3.4.5.4	Summary of FEA Results	31

3.4.6	Calibration Systems .....	32
3.4.6.1	Inside the Scintillator Volume .....	32
3.4.6.2	Inside the Buffer Oil Volume .....	32
<b>4.0</b>	<b>Vendor contacts .....</b>	<b>33</b>

## 1.0 OVERVIEW

This summary document describes the results of conceptual design and cost estimates performed by LBNL Engineering staff between October 10, 2003 and March 12, 2004 for the proposed  $\theta_{13}$  neutrino experiment at the Diablo Canyon Power Plant (DCPP). This document focuses on the detector room design concept and mechanical engineering issues associated with the neutrino detector structures. Every effort has been made not to duplicate information contained in the last LBNL Engineering Summary Report dated October 10, 2003. Only new or updated information is included in this document.

## 2.0 DETECTOR ROOMS

### 2.1 Detector Room Concept

There will be two detector rooms, referred to hereafter as the near and far rooms separated by a distance of 0.5 to 1 km. Each room will be rectangular in shape and have a roof with an elliptical profile.

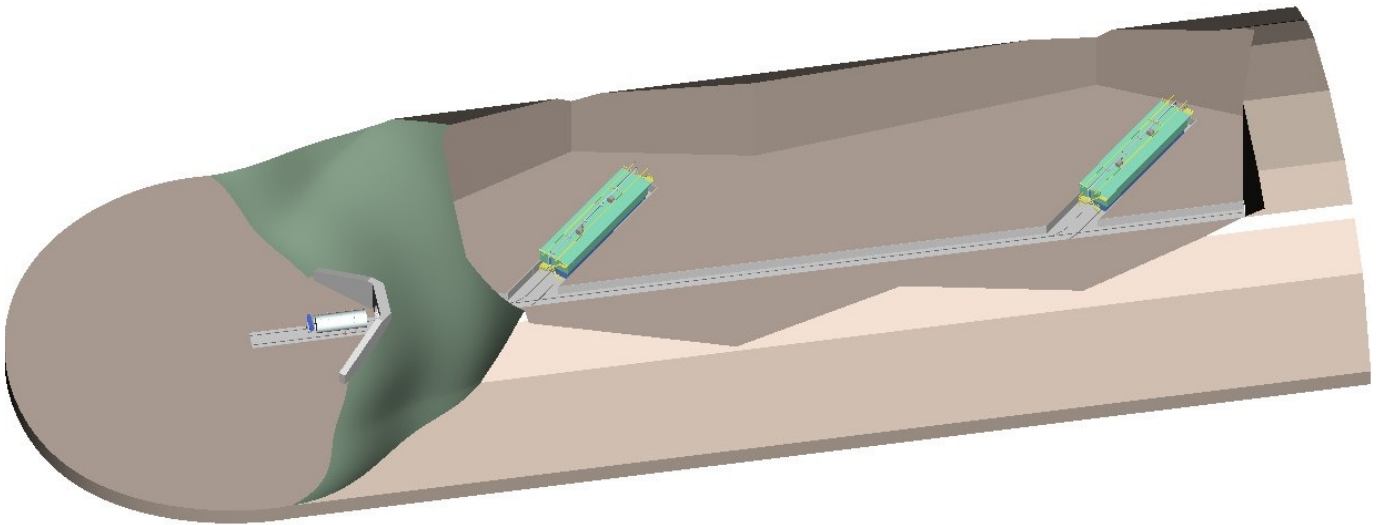

**Figure 2.1. Theta13 facility concept showing detector rooms, cutaway view, tunnel length not to scale.**

Inside length	45	m
Inside width	10	m
Inside height (at crown)	10	m
Internal volume	4307	m <sup>3</sup>

**Table 2.1. Detector room parameters.**

Both rooms will have adequate volume and infrastructure to accommodate two movable detectors simultaneously. The access doors, shielding doors, muon tracker detector, and

utility and safety systems will be compatible with periodic removal and replacement of detectors for calibration purposes on an annual basis.

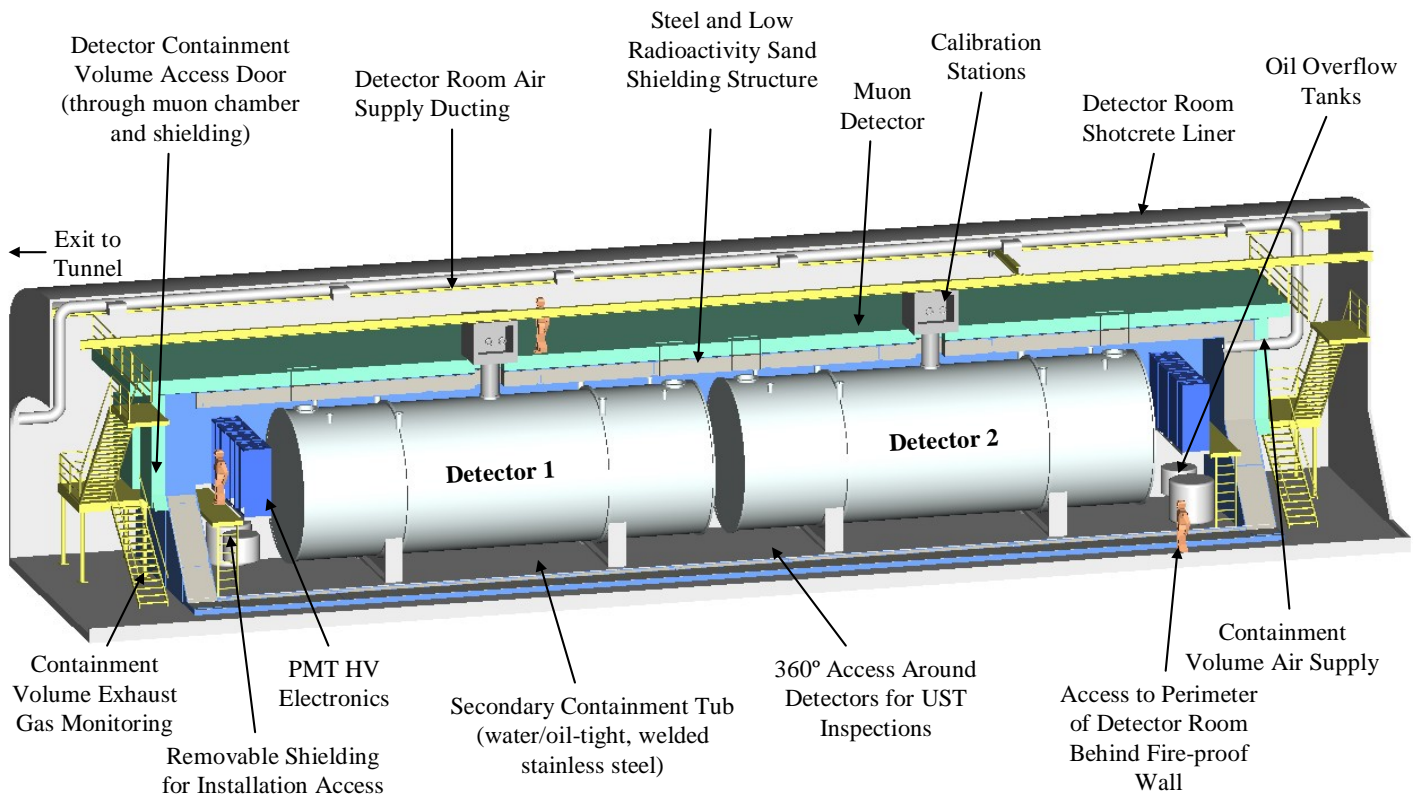

**Figure 2.2. Detector room concept, cutaway view.**

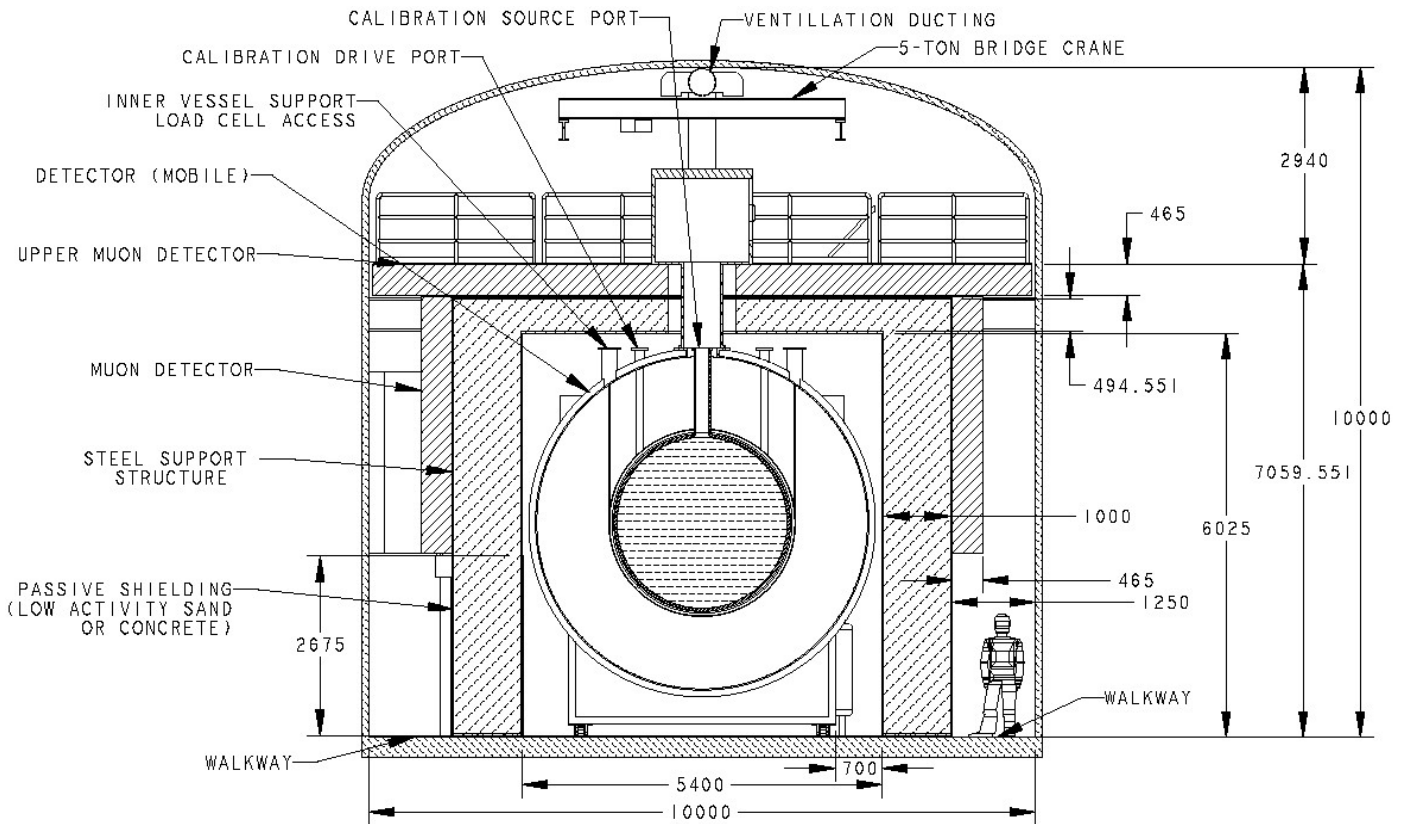

**Figure 2.3. Detector room cross-sectional view.**

## 2.2 Access and Interface with Tunnel

Each detector room will be connected to the main tunnel by a short drift at an angle of 45 degrees to the drive axis of the tunnel. This drift will contain a fireproof bulkhead at the intersection with the tunnel as well as an inner bulkhead that will separate the clean environment of the detector room from the tunnel atmosphere. The bulkheads, or panels within them covering a minimum area of 6 by 6 square meters, will be removable or hinged in order to allow installation and removal of the detectors as well as equipment, such as forklifts. Each bulkhead will contain a personnel access door. At least two people will be entering the rooms on a daily or weekly basis to perform technical tasks and safety inspections.

A shotcrete liner will cover the walls of the each room and will be watertight. Plumbing will be provided to allow water to drain from behind the liner into the tunnel drainage system. Water drainage gutters will be provided around the perimeter of the room.

## 2.3 Radiation Shielding and Support Structure

The detectors will operate inside a shielding structure to prevent naturally occurring gamma radioactivity in the surrounding rock, soil and concrete from interfering with the experiment. Intrinsic radioactivity of the surrounding environment is due largely to the decays of Potassium(40), Thorium(232) and Uranium(238).

Outside length	37	m
Outside width	7.5	m
Outside height	6.55	m
Shielding thickness of walls	1	m
Shielding thickness of ceiling	0.5	m
Shielding thickness of floor	0.5	m
Mass of steel	326	tonnes
Mass of sand	1,372	tonnes
Internal volume	957	m <sup>3</sup>
Minimum clearance to liner	1.25	m

**Table 2.2. Shielding and support structure parameters.**

### 2.3.1 Shielding Description

The shielding structure will reduce the level of radioactivity from the surrounding rock and concrete by a factor of between 10 to 100. Sand or other small-grain aggregate material known to have a low intrinsic radioactivity will be utilized as shielding material. A steel structure composed of I-beams and plate will be erected to support the muon detection system and the calibration access gallery. This steel structure, referred to hereafter as the shielded bunker, will be filled with low-background sand. A sampling and testing process will have to be established to find a source of suitable sand at a rock quarry in the San Luis Obispo area. The company Hanson Aggregates of San Luis Obispo, CA has indicated that there are several quarries in the area from which material could be obtained for testing and construction. The sand will be transported to the site at a cost of \$75 per hour per truckload. A conveyor belt will carry the sand from trucks in the tunnel and deposit it inside the steel structure in the detector room.

The sand in the walls of the bunker will act as both shielding and target material for secondary emissions from cosmic rays. The floor of the detector room will be poured concrete with a unique formulation designed to have low intrinsic radioactivity such as sulfurcrete, a manufactured concrete containing sulfur.

### 2.3.2 Support Structure Description

All detector room systems are supported by a central support structure composed of structural steel I-beams and A36 plate. The exterior of the structure supports the muon chambers, personnel access stairs and platforms, and the calibration access gallery. The steel plates forming the walls and ceiling the structure support the weight of the low-background sand used for radiation shielding. The interior of the structure forms the shielded bunker and supports the magnetic compensating coils around the detectors, the secondary containment tub, and the personnel access platforms and ladders. The support structure is anchored to the floor and walls of the detector room to provide stability to all systems during seismic events. Space between the detector room liner and the outer surface of the support structure is reserved as a fireproof egress around either side of the



shielded bunker. This space will also be utilized for installation and maintenance of the vertical muon chambers around the perimeter of the support structure.

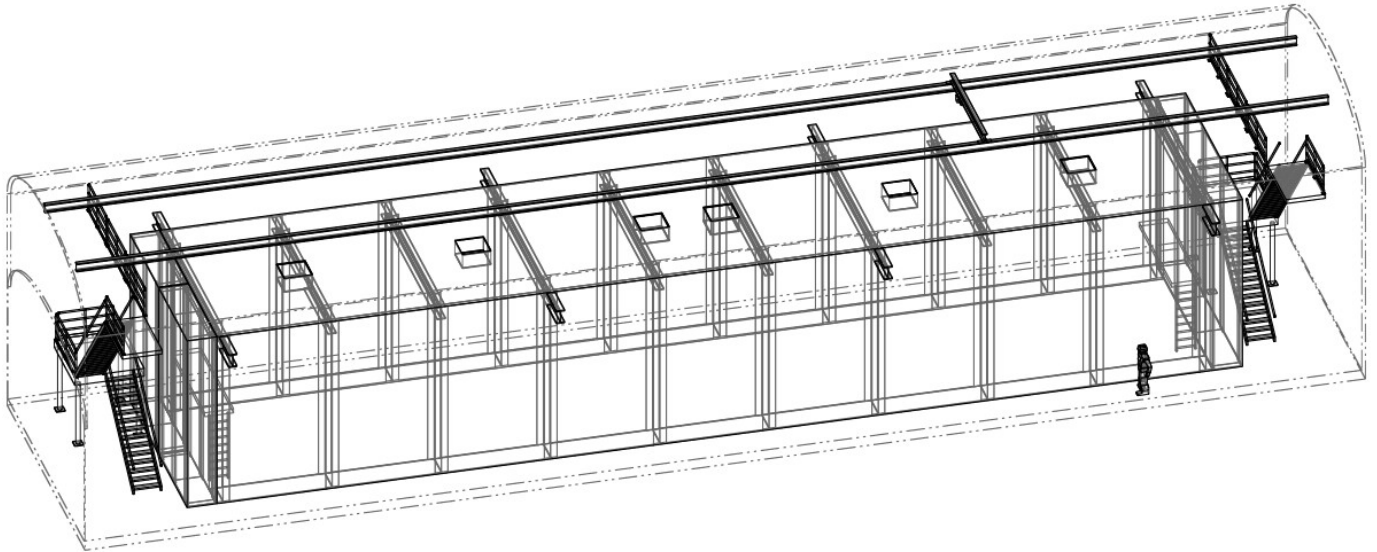

**Figure 2.4. Steel support structure inside the detector room.**

### 2.3.3 Shielding and Support Structure Cost Estimate

An estimate of the cost of the support structure and shielding was performed based on the total mass of structural steel and sand in the design. The total estimate for the support structure and shielding material was \$1,079,750 per detector room (see shielding and support structure cost estimation spreadsheet for details).

### 2.3.4 Access Inside Shielded Bunker

The shielded bunker will have removable doors on the end nearest the tunnel to allow the detectors to roll in and out of the room for installation and annual calibration purposes. The stairs and access platform on the tunnel side of the room will be moved using the overhead bridge crane or a forklift. The doors will incorporate tapered Hilman rollers to allow them to rotate out of the path of the detector.

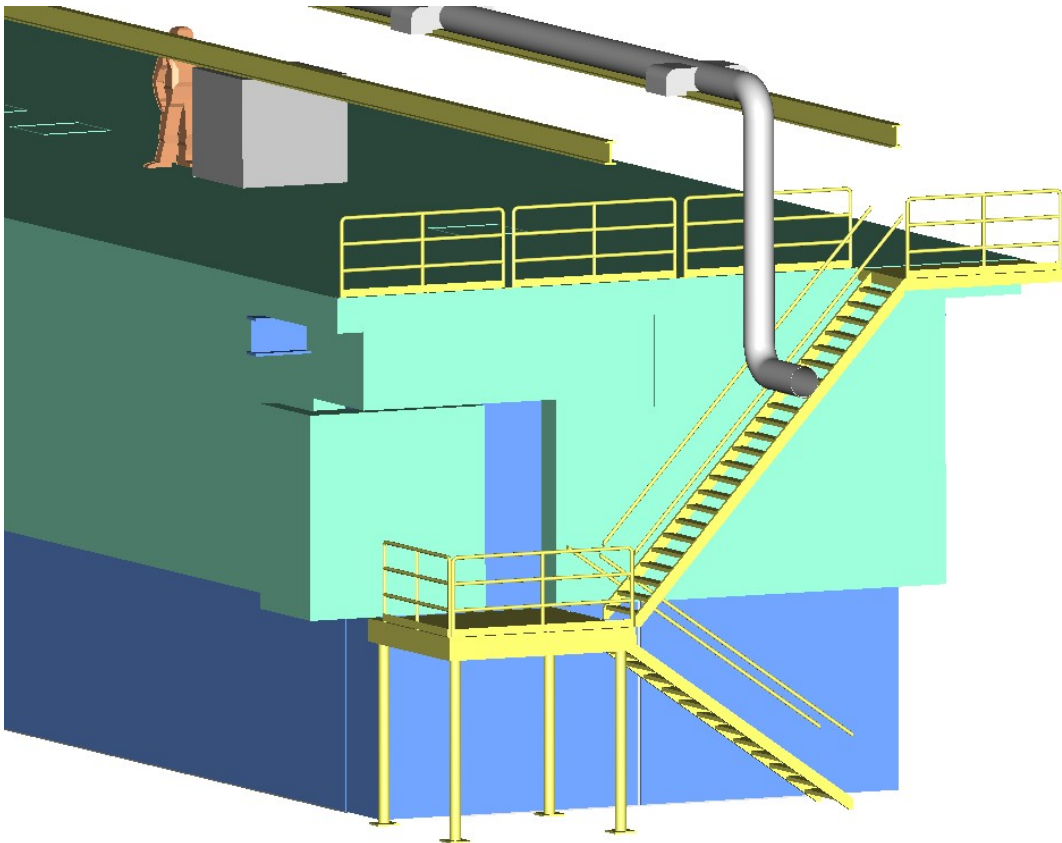

**Figure 2.5. Shielding bunker personnel access door.**

There will be a personnel door on either end of the bunker to allow access to the detectors, electronics, oil plumbing, and underground storage tank safety monitoring systems. This doorway will pass through both shielding material and the muon chambers on the end walls. The door will roll on guided rails laterally and will have a muon panel attached to its outer surface to allow safe and convenient access.

#### 2.4 Muon Detector System

The muon detector system will be mounted on the exterior of the support structure.

Chamber envelope thickness	465	mm
Overhand of upper level beyond side chambers	735	mm
Total area covered by chambers	748	m <sup>2</sup>

**Table 2.3. Muon system parameters.**

Most ends of the chambers will be accessible from either the calibration access balcony or the walkway around the shielded bunker. Six, one-meter square, removable panels are shown in the conceptual design of the horizontal muon chambers. The one-meter-square access areas extend through the shielding and support structure to allow attachment of hardware to the flanges on the ports of the detector tanks. The muon and shielding panels will be removed using the overhead bridge crane for calibration and maintenance

activities as required during operation. The muon chambers covering the bunker access doors move with the doors as they slide laterally outward.

## 2.5 Magnetic Compensating Coils

Magnetic compensating coils will be installed on the inside surface of the shielded bunker on the support structure plate. After excavation and construction of the detector room liner and support structure, the magnetic field in the region where PMT's will be located will be mapped using a Hall probe. The three-dimensional field vector will be sampled at several locations along the length of the bunker. According to the results of these measurements, coils will be installed to null the field in the location of the PMT's. An effort will be made to utilize nonmagnetic material inside the compensating coil volume. For example, the tracks used by the Hilman rollers under the detectors will be stainless steel inside the shielded bunker.

Depending on the smoothness and orientation of the terrestrial magnetic field profile inside the bunker, longitudinal coils, transverse coils, or coils with a combination of the two orientations will be installed in the bunker. Where the coil conductors cross the detector tracks or the parting lines of the movable bunker doors, connectors will be included so that the detectors can be removed with minimal reassembly of the compensating coil system.

## 2.6 Infrastructure and Utilities

Each detector room will have adequate utilities and infrastructure to accommodate operation of two detectors simultaneously. A minimal system of access stairs, ladders, and platforms will be installed to sustain regular operation and maintenance activities as well as annual locomotion of detectors between the near and far detector rooms. During construction activities additional infrastructure, such as scaffolding, additional ventilation, water and power will be temporarily installed. Several permanent systems identified thus far are described in this section.

### 2.6.1 Heating Ventilation and Air Conditioning

The design of the ventilation system for the facility is driven by radon gas concentration, personnel occupancy, temperature, humidity, and cleanliness requirements.

Total detector room volume	8,614	m <sup>3</sup>
Tunnel volume	29,357	m <sup>3</sup>
Required number of air exchanges per day in detector room	24	changes
Air flow rate in each detector room	2500	ft <sup>3</sup> /minute
Required number of air exchanges per day in the tunnel	6	changes
Air flow rate in tunnel	5000	ft <sup>3</sup> /minute
Temperature inside detector room	62 ±1	°F
Relative humidity	50 ±1%	RH
Heat load per detector room	20	kW

Maximum concentration of radon gas in detector room	50	Bq/m <sup>3</sup>
Cleanliness requirement inside the detector room	100,000	FED STD 209E Classification

**Table 2.4. Theta13 facility HVAC parameters**

2.6.1.1 Radon Gas Requirements

Radon is a naturally occurring radioactive gas that originates from the decay of uranium and thorium in rocks and soils. Fresh air will be continuously pumped into the detector room through a duct in the tunnel. The fresh air will be blown through the detector room volume, out through the detector room bulkheads, into the tunnel, and exhausted out vents in the tunnel entrance structure away from the air intake. The junctions in the sheet metal ductwork in the tunnel (22-inch diameter) will be sealed to prevent seepage of radon gas and water into the fresh air supply.

2.6.1.2 Temperature, Humidity, and Cleanliness Requirements

The heating ventilation and air conditioning (HVAC) system will consist of an air handling unit (heat exchanger, fan, steam humidifier), chiller, and hot water boiler. Air will be heated or cooled and dehumidified or humidified outside the tunnel to bring it to equilibrium with the facility air. Preconditioning of the air at the surface will enable equilibrium conditions within the detector room to be maintained regardless of the season of the year. In order to decrease the expense of the HVAC system, a nominal temperature and humidity have been selected for the experiment that will be similar to the naturally occurring underground conditions. Because most of the facility is underground at a naturally stable year-round temperature, the ducting will not require insulation in the tunnel.

HEPA filters will be included in the detector room duct system to maintain cleanliness in the experimental area. The area between the two bulkheads at the intersection of the detector room with the tunnel will be utilized as an anteroom area for the transition to the clean environment.

2.6.1.3 Personnel Occupancy Requirements

At an average rate of consumption of 200 CFM per person, the maximum constant occupancy will be approximately 25 people for the facility, 13 people per detector room.

2.6.1.4 HVAC Budgetary Cost Estimate

The LBNL Facilities engineering group recommended the HVAC system described above and has estimated the installed cost at \$829,672. A forty percent contingency has been recommended for this estimate. In addition a subcontractor overhead and profit margin of 19 percent has been predicted bringing the total budgetary estimate to \$1,319,178.

### 2.6.2 Overhead Crane and Material Handling

A 5-ton capacity overhead bridge crane will be installed in the ceiling of each detector room. The rails of the crane will run the length of the room and have a width of approximately four meters. This light duty crane will be used to handle equipment during installation and normal operation. Specific functions of the crane during operation include removing and replacing panels in the shielding and muon chambers to gain access to the detector ports and moving equipment from the floor of the detector room to the upper level. Items heavier than 5-tons will be moved by forklift or mobile crane during construction and locomotion activities.

### 2.7 Underground Storage Tank Design

The detector tanks will be regulated as underground storage tanks (UST) by the California Environmental Protection Agency State Water Resources Control Board.

*An underground storage tank (UST) is defined by law as "any one or combination of tanks, including pipes connected thereto, that is used for the storage of hazardous substances and that is substantially or totally beneath the surface of the ground" (certain exceptions apply).*

Source: <http://www.swrcb.ca.gov/cwphome/ust/>

The general purpose of the UST regulations is to protect public health and safety and the environment from releases of petroleum and other hazardous substances from underground tanks. The primary reasons for the regulation in the case of the Theta13 experiment are: the incompatibility of the fluid contents with drinking water, and the operation of the tanks with more than 10 percent of the contents underground.

#### 2.7.1 Summary of Relevant UST Requirements

The following subset of UST requirements have guided the conceptual design of the detectors and the detector rooms:

(summarized from source:

[http://www.swrcb.ca.gov/cwphome/ust/regulatory/docs/CCR\\_Title23%205\\_14\\_01.pdf](http://www.swrcb.ca.gov/cwphome/ust/regulatory/docs/CCR_Title23%205_14_01.pdf))

- 1) All new underground storage tanks and associated piping used for the storage of hazardous substances shall have primary and secondary containment.
- 2) Secondary containment may be manufactured as an integral part of the primary containment or it may be constructed as a separate containment system. Secondary containment systems shall be designed and constructed such that the secondary containment system can be periodically tested.
- 3) The design and construction of all primary containment shall be approved by an independent testing organization in accordance with industry codes, voluntary consensus standards, or engineering standards. All other components used to construct the primary containment system, such as special accessories, fittings, coatings or linings, monitoring systems and level controls shall also be approved by an independent testing organization.

- 4) In the case of multiple primary containers within a single secondary containment system, the secondary containment system shall be large enough to contain 150 percent of the volume of the largest primary container within it, or 10 percent of the aggregate internal volume of all primary containers within the secondary containment system, whichever is greater.
- 5) The secondary containment system shall be equipped with a collection system to accumulate, temporarily store, and permit removal of any liquid within the system.
- 6) The floor of the secondary containment system shall be manufactured on a firm base and the monitoring and collection volume must be enclosed in a security structure that will protect the system from entry of surface water, accidental damage, unauthorized access, and vandalism.
- 7) Secondary containment systems using membrane liners shall be tested after installation and approved by an independent testing organization in accordance with industry codes, voluntary consensus standards, or engineering standards. A membrane liner shall contain no primary nutrients or food-like substances attractive to rodents.
- 8) Underground storage tanks with secondary containment systems shall be designed and installed so that any loss of a hazardous substance from the primary containment will be detected by an interstitial monitoring device.
- 9) Both liquid level sensing and vapor detection are required in the interstitial space.
- 10) Monitoring of the interstitial space shall include either visual monitoring of the primary containment system or mechanical and electronic sensing.
  - a. A visual monitoring program must incorporate:
    - i. All exterior surfaces of the underground storage tanks and the surface of the floor directly beneath the underground storage tanks shall be capable of being monitored by direct viewing.
    - ii. For facilities where personnel are not normally present and inputs to and withdrawals from the underground storage tanks are very infrequent, visual inspection shall be made weekly. The inspection schedule shall take into account the minimum anticipated time during which the secondary containment system is capable of containing any unauthorized release.
    - iii. If any liquid is observed around or beneath the primary containment system, the owner or operator shall, if necessary, have the liquid analyzed in the field using a method approved by the local agency or in a laboratory to determine if an unauthorized release has occurred. The owner or operator shall have a tank integrity test conducted, if necessary, to determine whether the primary containment system is leaking. If a leak is confirmed, the

- owner or operator shall comply with the applicable provisions of the UST code for reportable incidents.
- b. A monitoring program which relies on the mechanical or electronic detection of the hazardous substance in the interstitial space shall include both liquid level sensing and vapor monitoring.
    - i. The interstitial space of the tank shall be monitored using a continuous monitoring system that is independently certified for compliance with the UST code.
    - ii. The continuous monitoring system shall be connected to an audible and visual alarm system approved by the local agency.
- 11) A response plan which demonstrates, to the satisfaction of the local agency, that any unauthorized release will be removed from the secondary containment system within the time consistent with the ability of the secondary containment system to contain the hazardous substance, but not more than 30 calendar days or a longer period of time as approved by the local agency.

#### 2.7.2 UST System Design

The stainless steel detector tanks will be manufactured by a licensed UST fabricator who will be responsible for certification of the compliance of the tank and integral plumbing associated with filling, draining, and primary containment monitoring. The tank will be installed in the radiation-shielded bunker inside a secondary containment system designed as an integral part of the shielding support structure.

A secondary containment volume, or tub, consisting of welded sheet metal will be supported by the floors and walls of the shielding bunker. This containment tub will be continuous, except on the end of the bunker that the detectors pass through during installation and removal. Care will be taken during the installation of the detector roller tracks, floor anchors, and other fasteners to avoid puncturing the liner and seal planned penetrations. The access end of the containment tub will have a separate panel of thicker stainless steel plate that will seal to a flange on the end of the tub with a compressed, water and oil tight gasket. The structural support of this removable panel will be anchored to the fixed walls of the bunker surrounding the movable door sections. The secondary containment volume will be filled with water to verify its integrity prior to initial installation of the detectors and then on a periodic interval of one to three years.

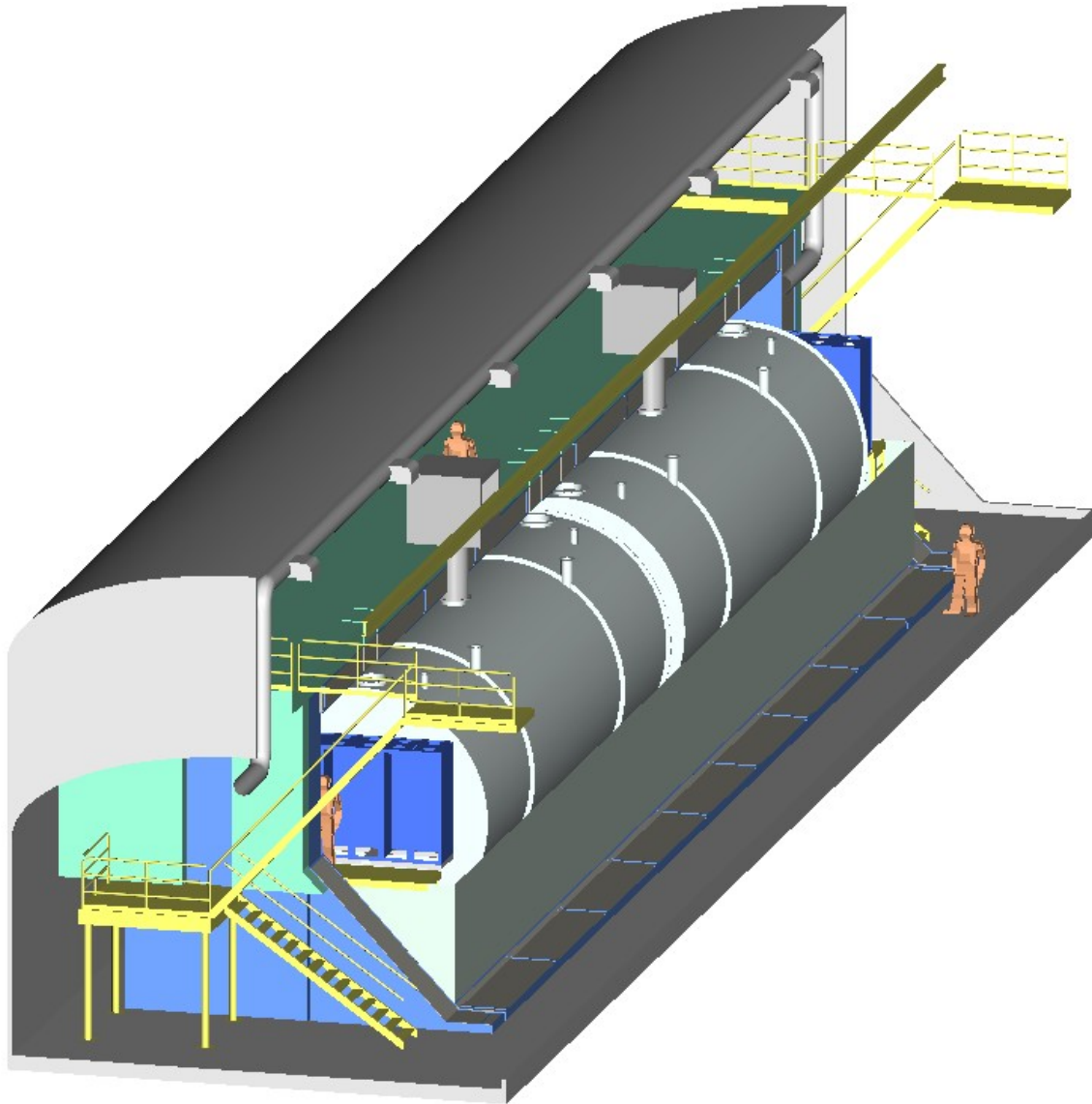

**Figure 2.6. Cutaway view showing the secondary containment tub around the detectors.**

Liquid level sensors as well as volatile organic vapor monitoring will be included inside the secondary containment volume. The ventilation system will maintain a slight positive pressure inside the bunker and the exhaust gas will be monitored with a vapor detection device, such as a photo ionization detector. If any of these systems malfunction or give a positive indication of the presence of a leak, all monitoring devices can be checked for proper function without interfering substantially with the experiment. In addition, all external surfaces of the tanks can be visually inspected, to determine the cause should an actual leak occur.

An alternative design was considered utilizing a second wall integrally connected to the primary containment wall of each tank. The double-walled tank approach was rejected because it would have rendered the interstitial volume as well as the primary containment



wall inaccessible for inspection and repair. In addition the double-walled design would have had a slightly larger outside diameter than the single-walled tank, necessitating more clearance in the tunnel and shielded bunker.

Personnel access doors, platforms, and electronics will be located above the maximum fill height of the containment tub. Ladders from the platforms to the floor of the tub will allow personnel to perform visual UST inspections under the tanks and around their entire perimeter. All overflow tanks and plumbing will be located within the volume of the secondary containment tub.

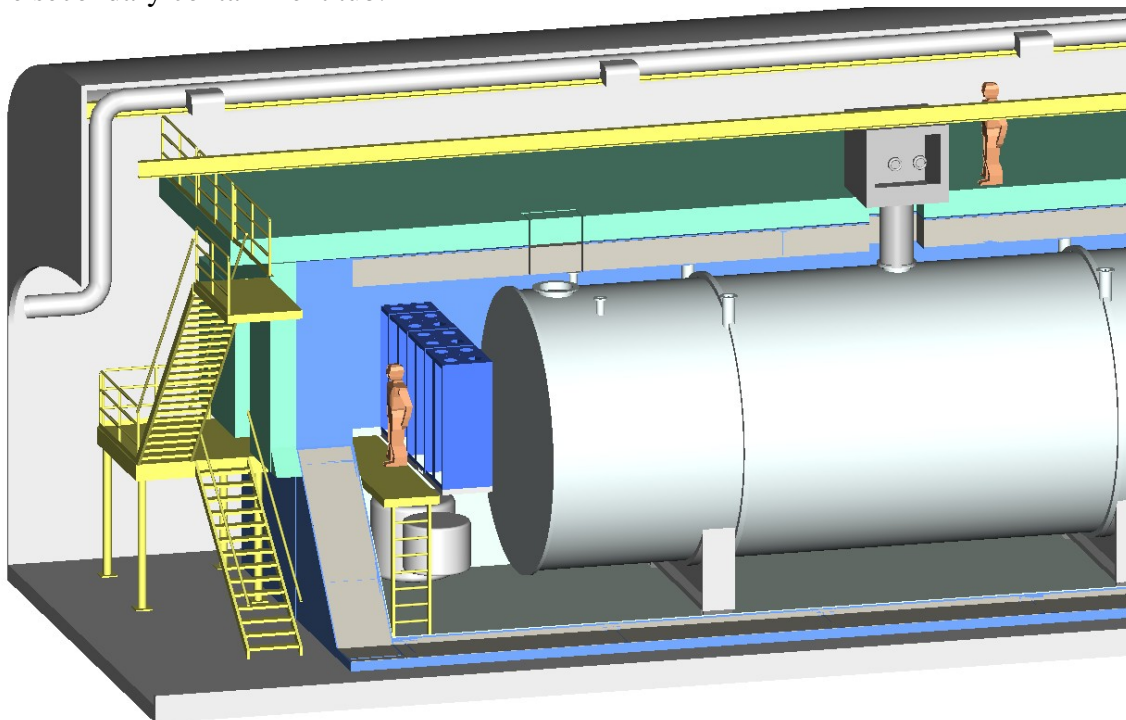

**Figure 2.7. Cutaway view showing the access platforms and electronics inside the shielded bunker.**

The UST regulations will not apply during transportation of the detectors once they are full of fluid. A separate secondary containment system and procedures will be installed and utilized during locomotion for calibration purposes. This system could consist of a combination of temporary sheet metal gutters attached to the mobile tank system and the positioning of other spill containment and cleanup systems during locomotion.

### 3.0 DETECTORS

#### 3.1 Overall Detector Concept

The Theta13 neutrino detector structure is unique compared to other comparably sized detector systems because of the necessity during calibrations to periodically move the detectors inside a tunnel over a distance of approximately one kilometer throughout the lifetime of the experiment. Each detector has a scintillator mass of 50 tonnes and must be operated in both the near and far detector rooms.

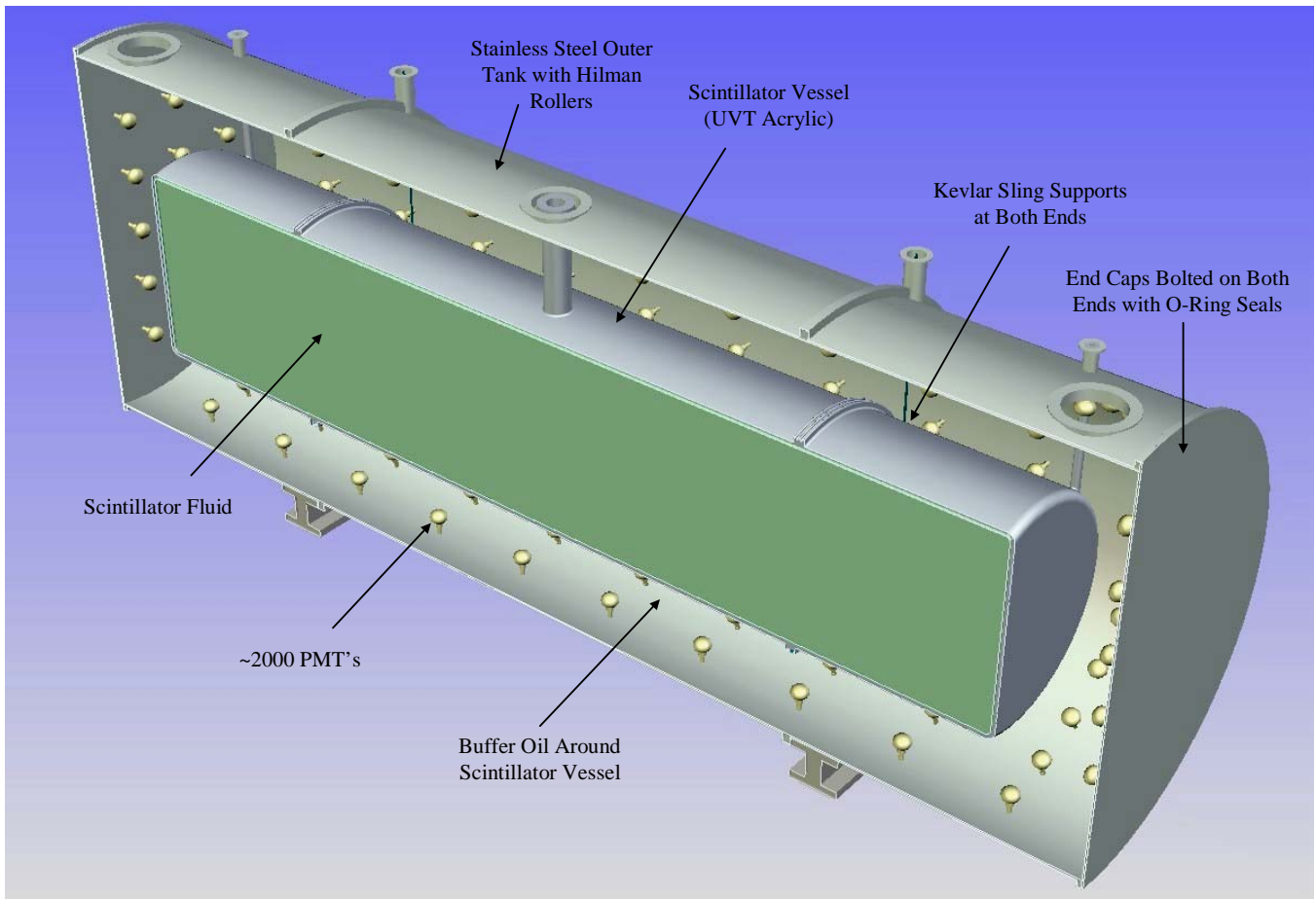

**Figure 3.1. Neutrino detector concept.**

Overall length	14	m
Outside diameter	5	m
Nominal mass of scintillator fluid	50	tonnes
Volume of scintillator fluid	64	m <sup>3</sup>
Nominal mass of buffer oil	154	tonnes
Volume of buffer oil	198	m <sup>3</sup>

Empty weight of outer tank	62	tonnes
Empty weight of scintillator vessel	4	tonnes
Total weight of detector	270	tonnes
Inside diameter of scintillator vessel	2.64	m
Inside length of scintillator vessel	11.64	m
PMT coverage	30%	
Number of PMT's per tank	2,064	

**Table 3.1. Neutrino detector parameters.**

While the ideal shape of a detector for stationary service from a physics and cost standpoint would be spherical, the Theta13 experimental approach necessitates a cylindrically shaped detector. Because of the separation between the near and far detection locations the overall cost of the experiment is a stronger function of the tunnel diameter, and therefore the detector diameter, than any other factor.

### 3.2 Mobile Detector Systems

A subset of the detector and auxiliary plumbing and electrical systems will be permanently assembled with the detector. Other systems will be replicated in each detector room. The mobile detector systems will be supported by the outer tank and will move with the tank during locomotion in the tunnel from the near to far detector rooms.

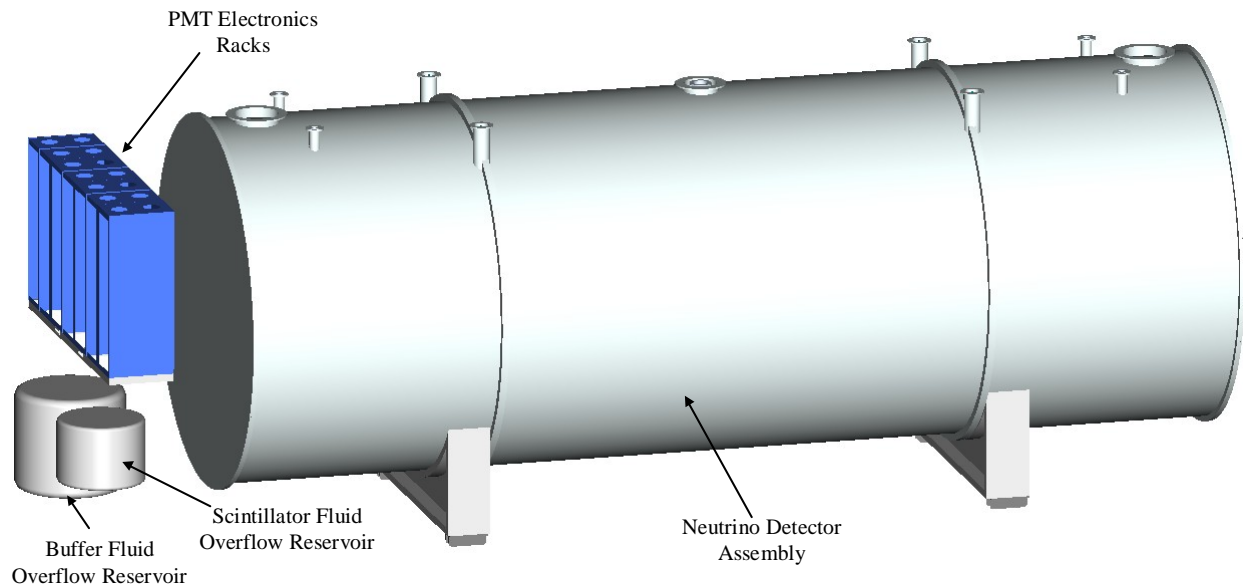

**Figure 3.2. Mobile detector systems.**

### 3.2.1 PMT Electronics Racks and Cables

The electronics racks (7 racks, each 24 x 36 x 90 inches) contain PMT high voltage power supplies and data acquisition VME crates. The high voltage cables connecting individual PMT's to the electronics need not be removed during locomotion for calibration purposes.

### 3.2.2 Oil Overflow Tanks

Because of the relatively high coefficient of thermal expansion of mineral oil and the large volumes contained in each detector, an overflow tank will be provided for each detector and for each oil system in each detector. The coefficient of thermal expansion of mineral oil is approximately  $6.4 \times 10^{-4}$  degree C<sup>-1</sup>.

The fluid overflow tanks and plumbing will move with the detectors in case of temperature changes during locomotion and to simplify installation and removal of the tanks from the detector rooms. The overflow tanks have been designed for a maximum temperature excursion of 25° C. Although the temperature inside the underground facility is likely to be relatively constant, the most likely scenario for a dramatic temperature excursion would be during a maintenance operation when a detector needed to be moved near or outside of the entrance to the tunnel.

#### 3.2.2.1 Scintillator Volume Overflow

The scintillator vessel in each detector contains 50 tonnes of mineral oil and has a volume of 63.7 m<sup>3</sup> (16,900 gallons). If the temperature changes by 25° C (10-35° C or 50-95° F), the volume will change by approximately one cubic meter (264 gallons). An overflow tank with a volume of one to two cubic meters would provide a conservative capacity for overflow of mineral oil from the scintillator volume resulting from temperature fluctuations.

#### 3.2.2.2 Buffer Volume Overflow

The outer buffer region of each detector contains 154 tonnes of mineral oil and has a volume of 197.4 m<sup>3</sup> (52,200 gallons). If the temperature changes by 25° C (10-35° C or 50-95° F), the volume will change by three cubic meters (834 gallons). An overflow tank with a volume of three to four cubic meters would provide a conservative capacity for overflow of mineral oil from the buffer volume resulting from temperature fluctuations.

### 3.3 Outer Tank (Detector Outer Tank)

The detector outer tank is a welded stainless steel structure fabricated using industrial liquid tank manufacturing techniques. The main features that make this tank unique are:

- The need for locomotion while full.
- The need to support the scintillator vessel and PMT structures inside the tank.
- The need for removable end caps to enable installation of the scintillator vessel and PMT hardware.
- The necessity for cleanliness inside the tank before subsequent assembly and filling.

### 3.3.1 Outer Tank Mechanical Design and Fabrication

The tank wall thickness is likely to be on the order of 0.25 inches in thickness. Structural ribs with a radial thickness of four to six inches will keep the containment wall from buckling during filling and seismic events. Additional structural ribs may be required in the areas where the scintillator vessel supports attach to the outer tank wall.

The tank will be supported on two saddle supports that will be anchored to the floor of the detector room during operation. Each saddle support will have a Hilman roller on either end for locomotion. The saddles may be connected by tie-rods during locomotion activities to uniformly distribute the loads from the winch or come-along propelling the mobile detector in the tunnel.

#### 3.3.1.1 Outer Tank Draft Fabrication Specification

1. This single walled, horizontal, cylindrical tank with flat ends will be installed in an underground room and will be regulated as an underground storage tank. A continuous liner installed separately in the underground room beneath the tank will accomplish secondary containment of the contents of the tank.
2. The inside diameter of the tank is nominally 5 meters and its inside length is nominally 14 meters.
3. The tank contains two types of fluid separated by a rigid acrylic tank mounted inside the outer tank. The inner acrylic tank contains a scintillator mixture composed of 70% dodecane (C<sub>12</sub>H<sub>26</sub>, density of 0.75 g/cm<sup>3</sup>) and 30% pseudocumene (C<sub>9</sub>H<sub>12</sub>, density of 0.876 g/cm<sup>3</sup>). The remaining volume of the tank is filled with pure dodecane.
4. The tank is under hydrostatic pressure only.
5. When full the tank and its contents weigh approximately 250 metric tons. When empty the acrylic vessel assembly inside the tank weighs approximately 8 metric tons. The tank and the acrylic vessel will be filled and drain simultaneously such that the acrylic vessel is never full when the outer tank is empty and vice versa.
6. The tank is supported by two saddle structures which, depending on the design of the tank, may be rigidly connected. Once the tank has been filled with fluid it will be moved periodically during operation. Locomotion will be accomplished with either Hilman rollers or air casters mounted beneath the support saddles.
7. The wall thickness will be the minimum required to limit deformation to less than one centimeter at all times, including during operation, seismic events, and locomotion.
8. The material is 316L stainless steel. Full material certifications and test coupons will be required. 316L has been selected because of its low radioactivity background as well as suitability for tank construction.

9. Welds are to be accomplished with non-thoriated tungsten electrodes (zirconium tungsten is suggested).
10. Both ends of the tank will have an end cap that can be sealed liquid tight under static liquid pressure for manufacturing acceptance tests and later reopened. The end caps will be removed during subsequent assembly operations but will not be removed during operation. Acceptable options for this joint include a bolted flange joint with an O-ring, a metal gasket, or a reusable welded interface.
11. The tank will not contain internal liquid baffles.
12. The highest magnitude dynamic loads on the tank will be from the tank contents during a seismic event. No significant loads are expected during moving operations because of low acceleration requirements. The seismic structural criteria should meet standards for structures in the San Luis Obispo, Avila Beach, CA region (a minimum requirement of 0.5 g lateral and vertical base loading is assumed for now).
13. There are several access ports on the top of the tank. All flanges will be located above the high liquid level and will have bolted and O-ring sealed covers. There are three 24-inch diameter ports along the top of the tank, down the centerline. There are four 8-inch ports for acrylic vessel vertical supports, and four 6-inch ports for calibration access. On the bottom of the tank there is one 2-inch drain port with a valve and secondary cover plate.
14. Inside the tank on the walls and end cap are several hundred welded bosses that will support instrumentation (photomultiplier tubes). Between ten and 12 larger bosses will be included inside the tank for attachment of cables that stabilize the inner acrylic vessel during transportation and seismic events.
15. The tank interior is mechanically and chemically cleaned to remove all residues and should be compatible with Class 10,000 cleanroom requirements.

### 3.3.2 Outer Tank Procurement and Cost Estimate

Several qualified vendors are available in the U.S for the design and fabrication of the outer tanks. A suitable company will be selected through a competitive bid process to provide the engineering, detailed design, fabrication, and UST certification for the tanks.

As mentioned in the last LBNL Engineering Report, dated October 10, 2003, because of the complexity of the removable end cap and the need to provide a clean tank, a company that makes both tanks and autoclaves, Taricco Corporation, was approached to give a budgetary quote based on the specifications given above. Taricco Corp. provided a written rough order of magnitude estimate for \$750,000 per tank, based on a quantity of three units per LBNL Drawing Number 27A467. This price is expected to be less than or equal to the final price after competitive bidding for a complete tank with end flange

access, internal mounts, saddles, shipping to customer site, and field erection as needed. This price also includes engineering and detailed fabrication drawings for the tank.

### 3.3.3 Locomotion System and Roller Cost Estimate

The mobile detector systems will utilize Hilman rollers and a 2 x 6” flat bar track recessed in the floor of the tunnel to accomplish locomotion into the tunnel and between detector rooms. In order to move a detector from the main tunnel into a detector room the detector assembly must roll through a 45-degree turn off the drive axis of the tunnel.

Maximum mobile detector system weight	300	tonnes
Locomotion distance	1	km
Frequency of travel per year	1	round trip in tunnel
Duration of experiment	10	years
Minimum turn radius	10	m
Turn angle	45	degrees
Average bearing pressure on floor under roller track	1,900	psi
Peak bearing pressure on floor under roller track	3,800	psi

**Table 3.2. Locomotion parameters.**

Since the last LBNL Engineering Report, dated October 10, 2003, Hilman revised the recommended system for locomotion of the detectors. Each detector will be equipped with four 150-ton capacity rollers, Accu-Roll guidance systems, and a turntable atop each roller. The rollers on one side of the detector will contain a “slider top” bearing mechanism designed by Hilman. The turntables and “slider tops” will allow the detector to roll through the 45-degree turn. The “slider tops” are necessary on two of the four rollers per detector to keep the guidance system from becoming overly constrained as the first set of rollers enter the curved section of track and the detector begins to rotate while the rear rollers are still riding on the straight track. A neoprene rubber pad on top of each roller will help to evenly distribute weight as the flatness of the track changes. The 150-ton capacity was selected to increase the lifetime of the rollers and allow the detector to ride on three wheels, if necessary, without over stressing the roller that temporarily bears half of the weight of the detector. Because of the likelihood of water and mud in the tunnel tracks, the rollers will be made of stainless steel.

Hilman has provided a revised budgetary cost estimate of \$11,000 per roller, for a total of \$44,000 per detector.

### 3.4 Scintillator Vessel (Acrylic Vessel)

The scintillator vessel is an optically transparent cylindrical containment structure that holds the scintillator fluid. This is a vessel made of clear acrylic that will be suspended

inside of the stainless steel outer tank. The volume of the steel tank not occupied by the scintillator vessel will be filled with a mineral oil buffer liquid.

#### 3.4.1 Mechanical Design and Fabrication

The scintillator vessel will be made of UVT acrylic (no ultra violet stabilizers, or inhibitors used) and will have a wall thickness of approximately one inch. While it is mechanically possible to use a cylinder with a thinner wall, a thicker wall will help minimize deflection, maximize the structural area of bond joints, and distribute localized applied load over a larger material volume. Every effort will be made to avoid sharp transitions between surfaces to maximize the optical transparency of the entire structure. For example, the ends of the vessel will be flat, rather than curved, and the ends will be bonded to a transition ring with a radius of four to six inches, rather than directly to the cylindrical section of the main vessel.

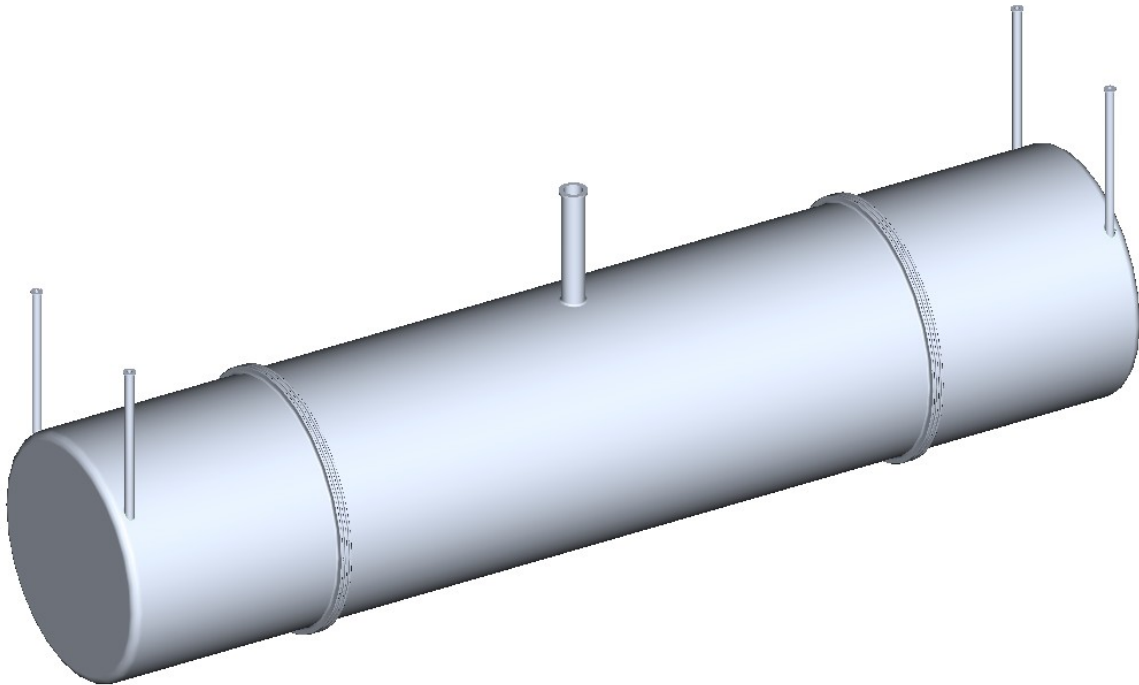

**Figure 3.3. Scintillator vessel made of acrylic.**

Reynolds Polymer Technology, Inc., a commercial company that has been identified as an acrylic fabricator with capability to make these vessels, has given conceptual guidance on the design of the tank. The vessel has a larger inside diameter than commercially available spin-cast acrylic rings. Reynolds manufactures 96-inch rings in lengths up to 90 inches and wall thicknesses up to one inch. The finished inside diameter of a 96-inch ring, with a one inch wall, is 93.5 inches (actual outside diameter is 95.5 inches). The necessary inside diameter of the Theta13, 50-ton, scintillator vessel is approximately 104 inches. Because of its large diameter the vessel will be constructed with heat formed acrylic panels bonded together with acrylic resin. All bonds will be annealed to reduce residual stresses. Each bond line will be optically polished on the inside and outside of the vessel. This optical polishing requires the fabricator to make provisions for access of technicians inside the vessel through a 36-inch opening throughout most of the fabrication process. The final bond of the cover and port over the access hole may have



lower optical properties due to the inaccessibility of the inside of the bond line for final polishing.

#### 3.4.1.1 Draft Fabrication Specification

1. The material is ultraviolet transmitting (UVT) acrylic. Material certifications and test coupons will be required. The material has been selected for its optical transparency, its compatibility with the scintillator fluid mixture, and its low intrinsic radioactivity.
2. This vessel contains two types of fluids in a scintillator mixture composed of 70% dodecane (C<sub>12</sub>H<sub>26</sub>, density of 0.75 g/cm<sup>3</sup>) and 30% pseudocumene (C<sub>9</sub>H<sub>12</sub>, density of 0.876 g/cm<sup>3</sup>).
3. This vessel is under hydrostatic pressure only.
4. The fluid inside the vessel has a mass of approximately 50 metric tons.
5. During operation this vessel is mounted inside a larger tank containing pure dodecane. The vessel and the outer tank will be filled and drained simultaneously such that the acrylic vessel is never full when the outer tank is empty, and vice versa.
6. All features of the tank will be designed to limit tensile and compressive stresses in the acrylic to 600 psi.
7. The highest magnitude dynamic loads on the vessel will be from the liquid contents during a seismic event. The vessel shall be designed for 1 g of vertical gravitational acceleration in combination with 0.5 g vertical and 0.5 g lateral seismic loading.
8. There are several ports on the top of the vessel that will extend through the outer tank volume to access ports that can be opened to the atmosphere. All flanges will have compressed O-ring sealed covers.
9. The tank interior is mechanically and chemically cleaned to remove all residues and should be compatible with Class 10,000 cleanroom requirements.

#### 3.4.2 Budgetary Cost Estimate

Reynolds Polymer Technology, Inc. has provided a written rough order of magnitude cost estimate for the acrylic vessel. The dimensions of the vessel quoted are: 1-inch wall with a 100.4-inch inside diameter and an internal length of 458.3 inches. The total cost for three vessels was quoted as \$652,272.00. This cost includes engineering and detailed fabrication drawings of the vessel. This cost does not include items for which specific information was not available at the time of the quote, including reinforcement ribs, calibration access ports, and transportation costs. Reynolds has recommended an additional cost of 20 percent for the items not included in this total, bringing the total

budgetary estimate to \$782,726 for three vessels. Delivery time was estimated at five months, including engineering and fabrication.

If the diameter of the scintillator vessel were reduced adequately to allow pre-formed cylinders to be used it is possible the construction may be slightly cheaper and the number of bonds in the vessel could be somewhat reduced. Reynolds provided a general cost of \$4,500 per foot for 96-inch pre-cast cylinders. At this rate the pre-cast cylinder material for an 11.64-m cylinder, 96 inches in diameter, would be \$172,000.

### 3.4.3 Support Concept

The primary static support will be provided by a Kevlar sling on each end passing from a support flange on top of the outer tank, under the bottom of the vessel, and back up to another support flange on top of the outer tank. Each sling will provide vertical support to the vessel along half of its circumference and will allow positional adjustment, if necessary during assembly. It is not anticipated, or desired, to move the vessel once the tank is filled. The ropes will be located within grooves that area machined, or formed into the acrylic. The wall thickness will be thicker at the support locations to allow for machining grooves without reducing the nominal wall thickness. Kevlar is selected because it is not degraded by the mineral oil. The four ends of the vertical support ropes will be attached to load cells mounted to the flanges on top of the outer tank. These load cells will ensure that the static weight of the vessel is evenly distributed and can be monitored during installation and throughout the lifetime of the detector.

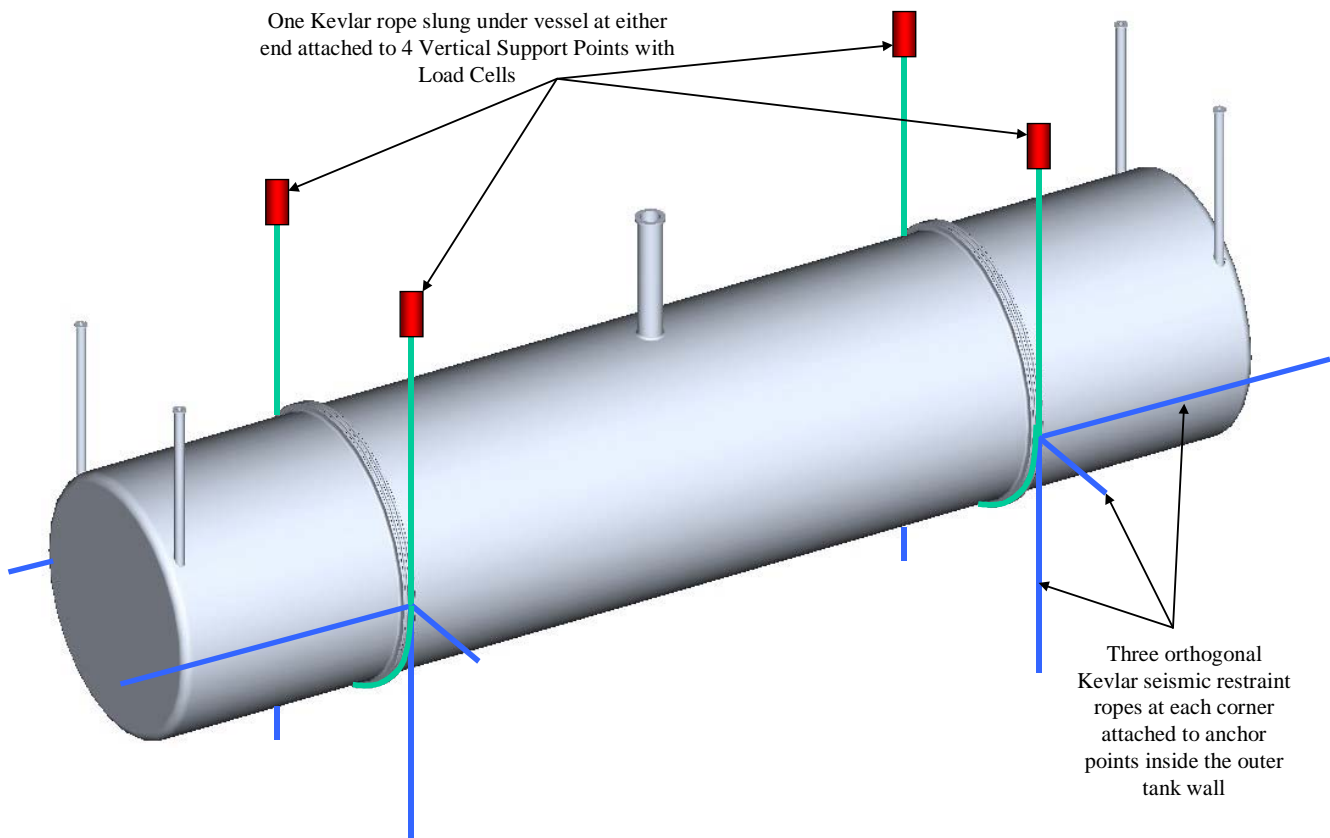

**Table 3.4. Scintillator vessel support concept.**

The vessel will also be stabilized with Kevlar ropes that will only apply forces on the tank during dynamic loading. Dynamic loads are only anticipated to act on the detector during seismic events and transportation. At the four points of tangency between the vessel wall and the vertical support straps, a somewhat optically transparent boss made of acrylic will reinforce the vessel wall and provide anchor points for the dynamic restraint ropes. Three orthogonal ropes will be connected between each boss on the inner wall of the tank. These ropes will be adjusted in length during installation to ensure minimal tension and positive engagement at both ends.

### 3.4.4 Stress and Deflection Analysis

Over the past 50 years the need for plastic viewports in submersible vehicles has resulted in well developed engineering techniques and material property data for acrylic plastics. The Theta13 experiment is unique in that the optical properties of the scintillator vessel are as important as the mechanical properties. Experience with acrylic structures submersed in fluids, such as water, for long periods of time indicates that crazing, the formation of micro cracks on the surface resulting from tensile stress, can occur at relatively low static stress levels. While commercial acrylic sheet can be expected to have an ultimate tensile and compressive strength in excess of 9000 psi, the goal for the Theta13 scintillator vessel design is to keep all static stress well below 1000 psi. A maximum allowable deflection of 5 mm has also been established for the vessel.

#### 3.4.4.1 Vessel Weight and Buoyancy

With a nominal wall thickness of one inch the acrylic vessel will weigh approximately 4 tonnes when empty. Once installed in the detector outer tank the buffer and scintillator volumes will be filled simultaneously to minimize differential pressure loads on the walls of the two fluid systems. The scintillator fluid, Pseudocumene, has a slightly higher density than pure mineral oil, Dodecane. When buoyancy forces are included the vessel is found to have a net weight, in the completed detector assembly, of approximately 4 tonnes.

<b>Water:</b>	density @60F = 62.4 lb/ft <sup>3</sup> = .0361 lb/in <sup>3</sup>
<b>Dodecane:</b>	specific gravity = 0.75
<b>Pseudocumene:</b>	specific gravity = 0.876
<b>Scintillator mixture:</b>	70% dodecane, 30% pseudocumene: net specific gravity = 0.788 density = 0.028 lb/in <sup>3</sup>
<b>Scintillator mixture suspended in dodecane</b>	net specific gravity = 0.788 - 0.75 = 0.038, net density = 0.038*0.0361 lb/in <sup>3</sup> = 0.00137 lb/in <sup>3</sup>
<b>Acrylic:</b>	specific gravity = 1.19

<b>Acrylic suspended in dodecane:</b> net specific gravity = $1.19 - 0.75 = 0.44$ net density = $0.44 * 0.0361 \text{ lb/in}^3 = 0.0159 \text{ lb/in}^3$
--

**Table 3.3. Density properties of fluids and acrylic.**

#### 3.4.5 Finite Element Analysis (FEA) Model

A simplified finite element model (ANSYS, version 7.0) was utilized to estimate the static and dynamic stress for two loading conditions. The goal of the analysis was to determine maximum stress and deflection for various wall thicknesses to facilitate a rough order of magnitude cost estimate of the vessel. A more detailed model and additional load cases will need to be considered to perform detailed design of the vessel.

The finite element model has 24,000 active degrees of freedom and employs vertical, half-symmetry. The vessel walls are modeled with four-node shell elements and the reinforcing material underneath the Kevlar ropes is modeled using eight-node brick elements. The scintillator fluid is approximated in the model with eight -node brick elements that have the density of the fluid but a modulus of elasticity equal to one millionth that of any other material in the model. Buoyancy is taken into consideration for vertical gravity loading by adjusting the density of all materials to simulate the immersion of the vessel in a larger volume of buffer oil. All results correspond to a completely full scintillator vessel and buffer volume.

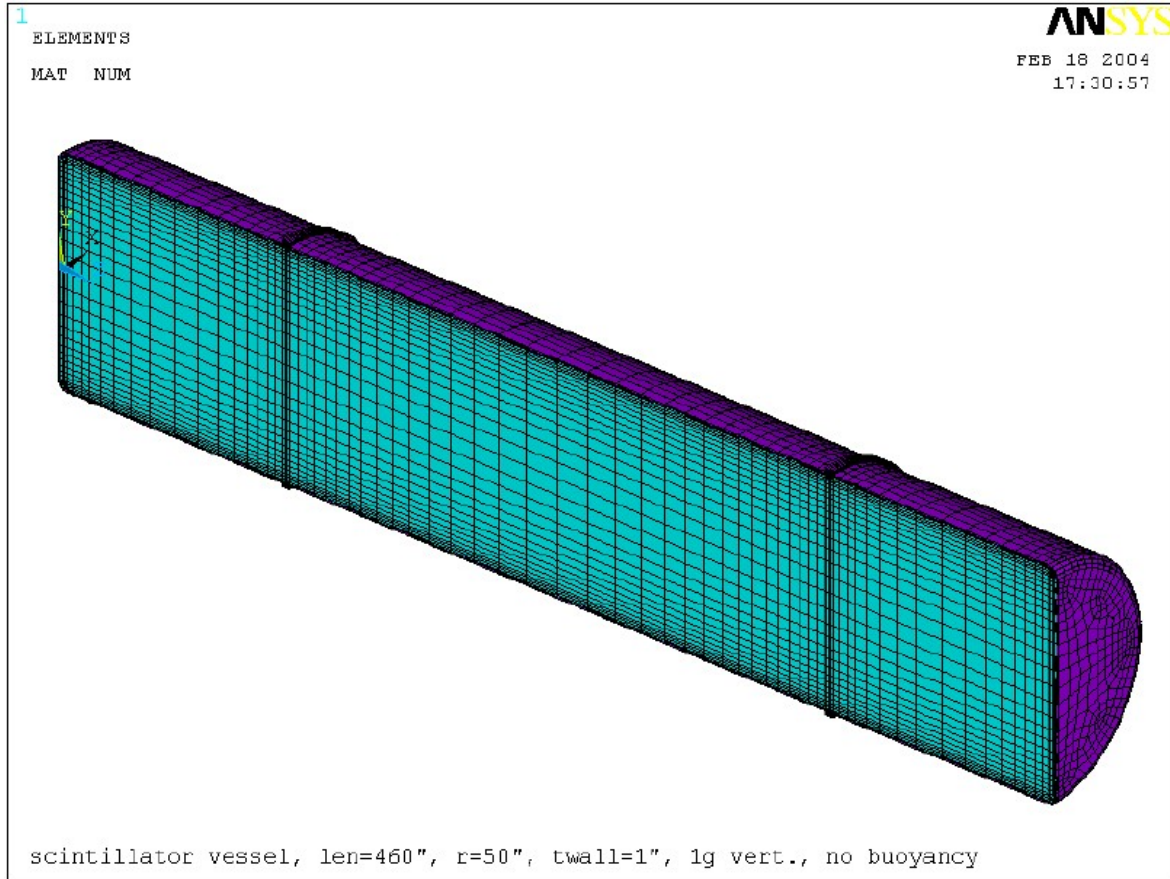

**Figure 3.5. Scintillator vessel finite element model.**

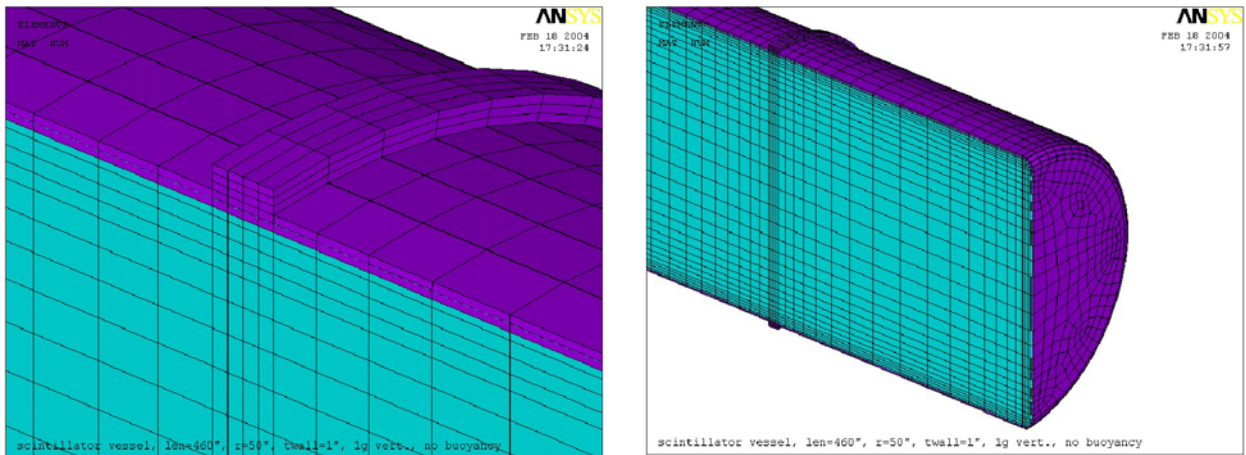

**Figure 3.6. Scintillator vessel finite element model mesh details.**

The vertical supports are simulated by setting the vertical displacement of the nodes on the lower half of the circumference of the vessel to zero. The dynamic restraints are modeled by setting a cluster of nodes at the attachment boss locations to zero only when those restraints act in tension (Kevlar ropes cannot act in compression).

### 3.4.5.1 Structural Loading Conditions

Although there are several loading conditions that will eventually be analyzed in the course of the preliminary design of the vessel, only two loading conditions were analyzed with this model.

- 1 g vertical gravity acceleration
- 0.5 g longitudinal acceleration during a seismic event

### 3.4.5.2 FEA Static Results

The maximum Von Mises equivalent stress was found to be well below 500 psi, in the bulk material and the reinforcing ring, for vessels with wall thicknesses between one-inch and one-half-inch. Thinner walls were not considered because of the impracticality of a very thin walled acrylic structure of this scale. The maximum static deflection was found to be well below 5 mm for vessels with wall thicknesses between one-inch and one-half-inch. In all cases the maximum static deflection occurred on top of the vessel.

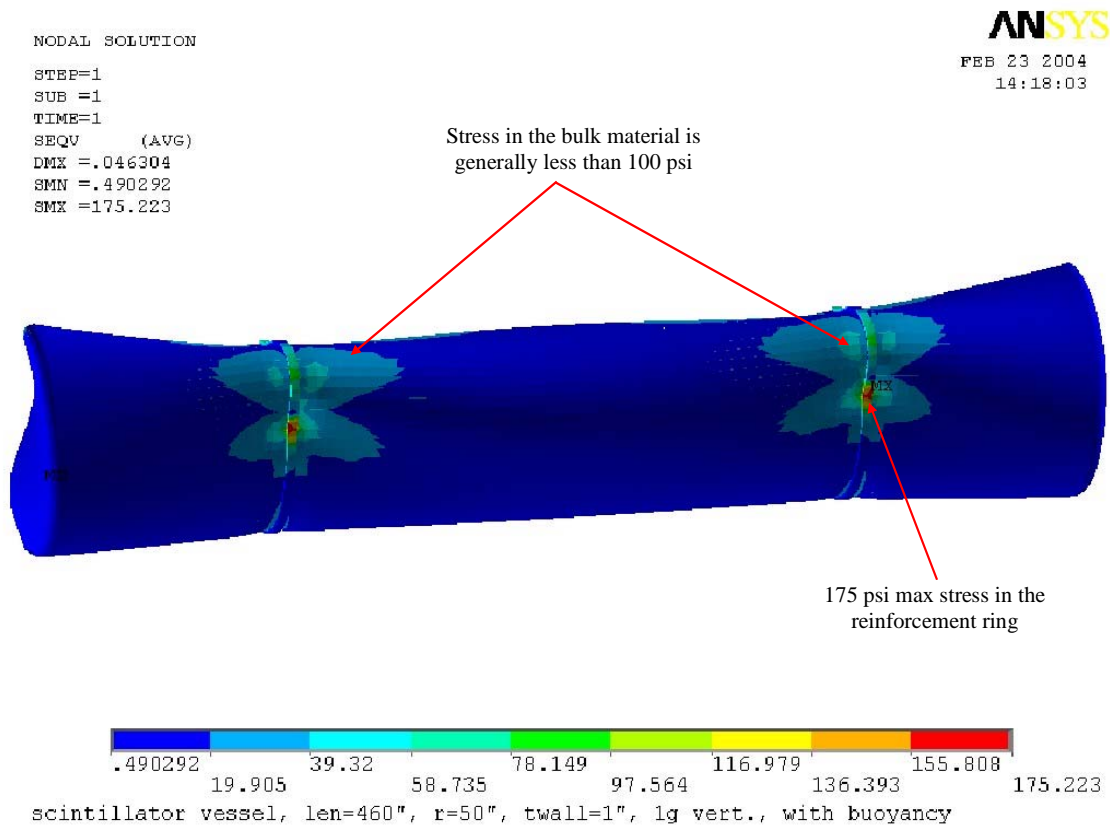

**Figure 3.7. Stress in vessel with 1-inch walls from static gravity loading, with buoyancy.**

NODAL SOLUTION  
 STEP=1  
 SUB =1  
 TIME=1  
 USUM (AVG)  
 RSY3=0  
 DMX =.046304  
 SMX =.046304

**ANSYS**  
 FEB 23 2004  
 14:16:58

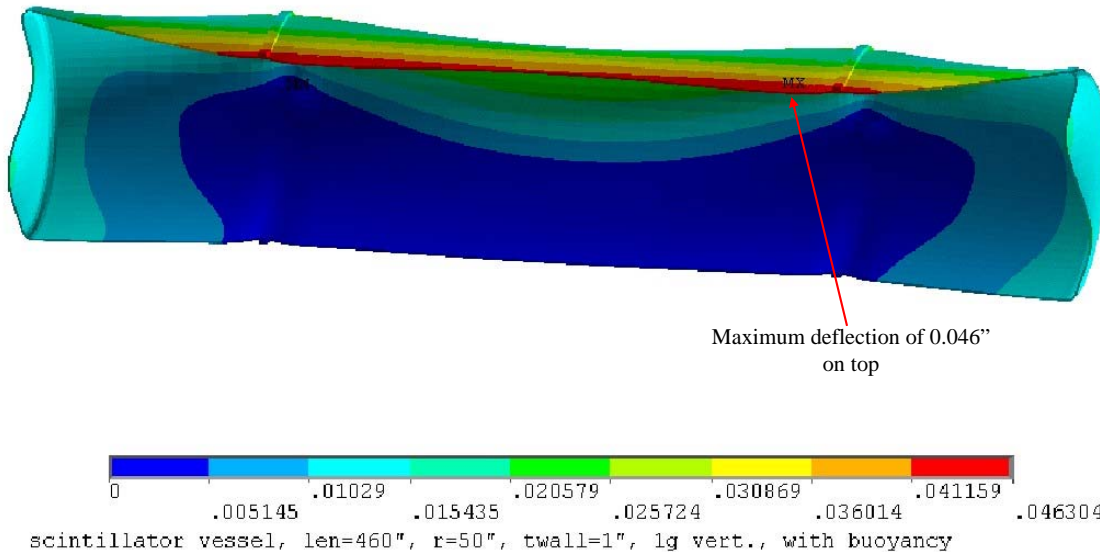

**Figure 3.8. Deflection in vessel with 1-inch walls from static gravity loading, with buoyancy.**

### 3.4.5.3 FEA Seismic Results

A 0.5 g longitudinal acceleration was selected for analysis of seismic loading because acceleration in that direction is likely to cause the most severe stress and deformation compared to other acceleration directions. The seismic result does not include gravity loading but the two results can be combined to obtain the total Von Mises equivalent stress for a particular element. A longitudinal acceleration is thought to produce the most severe result because nearly the entire mass of the vessel is supported in tension by two longitudinal ropes and the minimum cross-section of the vessel wall.

The maximum Von Mises equivalent stress observed in the model with one-inch walls as a result of the seismic acceleration was less than 3000 psi, well below the ultimate tensile strength of 9000 psi.

It should be noted that the end wall deflection under dynamic loading is not accurate because of the absence of buffer oil elements and the inertial and viscous affects they would have on the vessel. A maximum static deflection of nearly three inches was calculated with this model in the end walls of the vessel. This result indicates that it may be necessary to thicken or otherwise support the end walls and that more detailed modeling will have to be performed. This type of large deflection under dynamic loading would result in shock loads being transferred to the PMT structures. Because of the

delicacy of the PMT's around the scintillator vessel, shock loading should be minimized. A more detailed model containing the inertial and viscous properties of both fluid volumes should be performed.

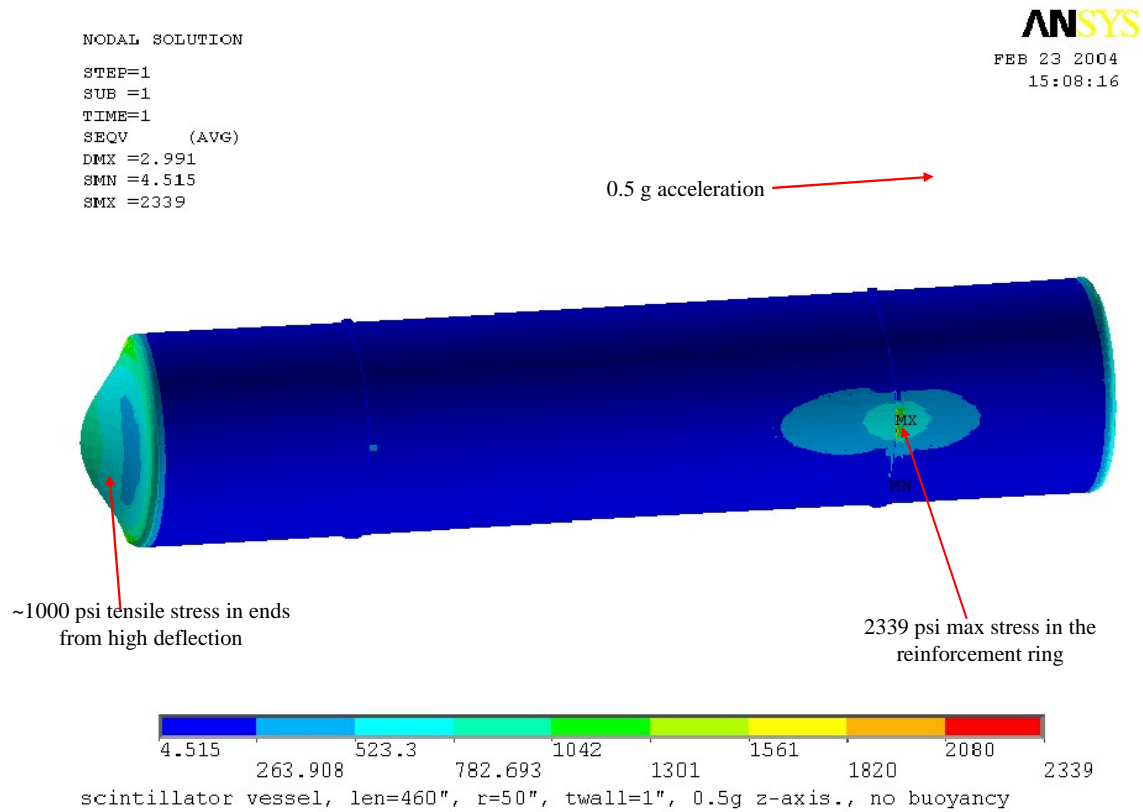

**Figure 3.9. Stress in vessel with 1-inch walls from 0.5 g longitudinal seismic acceleration.**



NODAL SOLUTION  
STEP=1  
SUB =1  
TIME=1  
USUM (AVG)  
RSYS=0  
DMX =2.991  
SMX =2.991

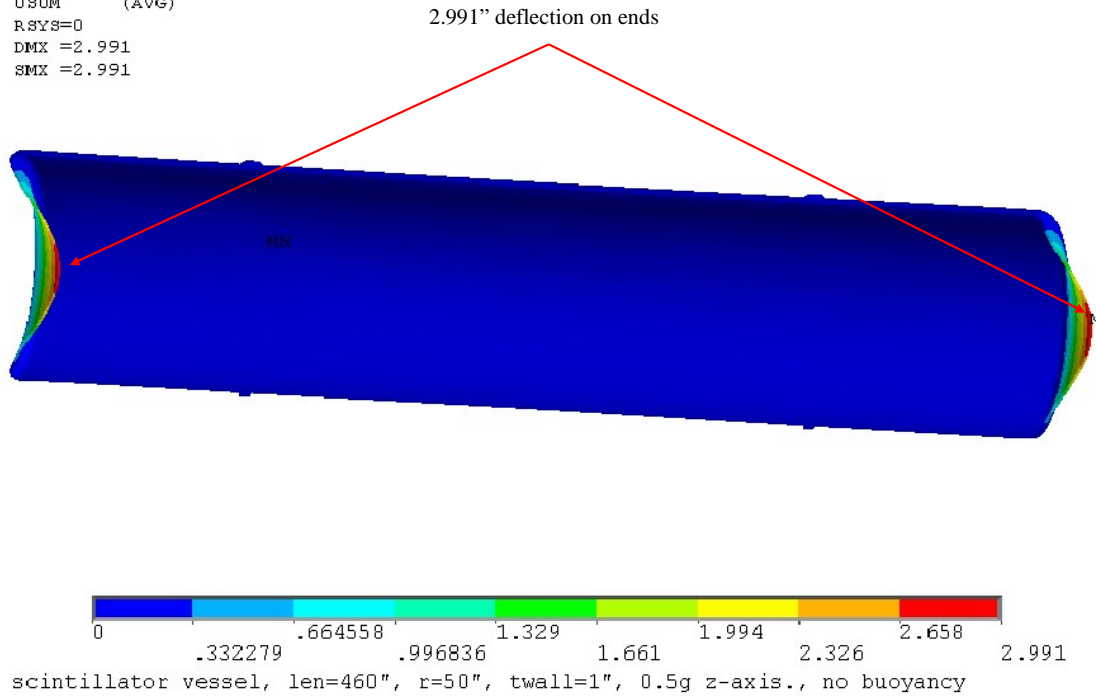

**Figure 3.10. Deflection in vessel with 1-inch walls from 0.5 g longitudinal seismic acceleration.**

3.4.5.4 Summary of FEA Results

Based on these finite element results a wall thickness of one inch is selected for the scintillator vessel. It is additionally noted that a more detailed analysis of the dynamic behavior of the vessel, the outer tank, and fluids should be completed to assess dynamic loading of the PMT structures resulting from viscous forces in the fluid.

Case	Result	Value	Notes
<b>Static, 1-inch wall</b>	Max stress in bulk material	100 psi	
	Max stress in reinforcing ring	175 psi	
	Max deflection	0.046 inches	on top
<b>Static, 1/2-inch wall</b>	Max stress in bulk material	150 psi	
	Max stress in reinforcing ring	304 psi	
	Max deflection	0.100 inches	on top
<b>Seismic, 0.5g longitudinal, 1-</b>	Max stress in bulk material	1000 psi	

<b>inch wall</b>			
	Max stress in reinforcing ring	2339 psi	
	Max deflection	2.991 inches	end wall deflecting

**Table 3.4. Scintillator vessel finite element results.**

### 3.4.6 Calibration Systems

#### 3.4.6.1 Inside the Scintillator Volume

A source mounting plate will be suspended inside the tank from four Kevlar ropes (less than 0.125 inches in diameter). A similar system was used in the SNO detector. The acrylic vessel will have four ports (one inch in diameter, or so) on the tank at 45 and 135 degrees, two at each end. The mounting plate will have a threaded hole that will act as a standard interface for various types of sources that will be inserted via a larger port (six inches or so in diameter) in the center on top of the tank. The sources are roughly four to five inches in diameter. Each rope will be driven with a stepper motor with an encoder. A loadcell on each rope will readout the tension in the rope. The position of the source can be derived from the tension and encoder readouts. Experience with the SNO system indicates that the position can be adjusted to within a couple centimeters using this approach. The source will be able to trace a rectangular volume equal in length and width to the spacing between the ports the ropes pass through.

In addition to radiation sources there will be a laser source (timing calibration) inserted into the tank. Generally the laser source consists of an external laser pointing the beam through a fiber that is then inserted into the volume. The end of the fiber can be attached to the source mounting plate.

#### 3.4.6.2 Inside the Buffer Oil Volume

The calibration system outside the scintillator volume is complicated by the necessity to avoid contact with the PMT's and the outer surface of the acrylic vessel. Neutron, gamma, and active sources will be moved throughout the buffer oil volume. A rail can be routed between the PMT's around the vessel that will guide a source carriage out of a shielded housing on top of the outer tank, around the volume, and back inside the housing. The rail and source carriage will be designed to intrude minimally into the buffer volume in front of the PMT image plane.

Many LED's (on the order of 100) will be positioned inside the tank. The LED's will emit in the infrared to enable simultaneous operation of the PMT's and the calibration system. Several cameras will be mounted inside the tank that will be used to calibrate the positioning system for the source inside the acrylic vessel. These cameras will either have fixed viewing angles or be adjustable and rely on LED targets to set positional zeros.

#### 4.0 VENDOR CONTACTS

- Reynolds Polymer Technology, Inc. (fabrication of acrylic scintillator vessel)  
<http://reynoldspolymer.com/>  
607 Hollingsworth St.  
Grand Junction, Co 81505  
970-241-4700  
fax: 970-241-4747  
Contacts:  
Mark Johnson, V.P. Business Development  
[mjohnson@reynoldspolymer.com](mailto:mjohnson@reynoldspolymer.com)  
cell: 970-433-2765  
Dave Duff, V.P. Engineering  
Keith Long, Production Manager
  
- Taricco Corporation (fabrication of detector outer tanks)  
<http://www.taricco.com>  
1500 West 16th Street,  
Long Beach ,CA 90813  
Phone (U.S.Toll Free): 800-425-2837  
Int'l & Local: (562) 437-5433  
Fax: (562) 901-3932  
Contact: Tari Taricco, president  
[tarit@taricco.com](mailto:tarit@taricco.com)
  
- Hilman Rollers (detector locomotion system)  
<http://www.hilmanrollers.com/>  
12 Timber Lane  
Marlboro, NJ 07746  
732-462-6277  
fax: 732-462-6355  
Contact: Garry Van Iderstine, Regional Sales Manager  
[gvaniderstine@hilmanrollers.com](mailto:gvaniderstine@hilmanrollers.com)
  
- Hanson Aggregates (shielding material)  
San Luis Obispo, CA  
805-543-8100  
Contact: Brent (sales)  
cell 805-610-0223