

# UC Irvine

## UC Irvine Previously Published Works

### Title

Trajectories of Perceived Technological Impairment and Psychological Distress in Adolescents

### Permalink

<https://escholarship.org/uc/item/3v09d892>

### Journal

Journal of Youth and Adolescence, 52(2)

### ISSN

0047-2891

### Authors

Burnell, Kaitlyn  
Odgers, Candice L

### Publication Date

2023-02-01

### DOI

10.1007/s10964-022-01679-1

Peer reviewed



# Trajectories of Perceived Technological Impairment and Psychological Distress in Adolescents

Kaitlyn Burnell<sup>1,3</sup> · Candice L. Odgers<sup>2</sup>

Received: 1 July 2022 / Accepted: 2 September 2022 / Published online: 26 September 2022  
© The Author(s), under exclusive licence to Springer Science+Business Media, LLC, part of Springer Nature 2022

## Abstract

Fears that digital technologies harm adolescents' mental health abound; however, existing research is mixed. This study examined how perceived technological impairment (i.e., perceptions of digital technology interfering with daily life) related to psychological distress across five years in adolescence. A latent curve model with structured residuals was applied to disentangle between- from within-person associations, in which it was tested whether (a) adolescents who increased in their perceptions of technological impairment over time also increased in psychological distress (between-person) and (b) if an adolescent who reported greater perceptions of technological impairment relative to their underlying trajectory at one wave consequently reported greater distress at the subsequent wave (within-person). These associations were tested in a sample of 2104 adolescents ( $M_{\text{age}} = 12.36$ ; 52% girls; 48% Non-White). Perceived technological impairment and psychological distress increased together over time. Girls and older adolescents (13–15 at baseline) reported greater initial levels of perceived impairment. Younger adolescents (9–12 at baseline) increased more steeply in perceived impairment over time. There was no evidence of longitudinal within-person associations. The findings suggest that although there is evidence of between-person associations in which increases in perceived technological impairment coincide with increases in psychological distress, the absence of within-person associations cautions against a cause-and-effect narrative between digital technology use and mental health.

**Keywords** Digital technology · Problematic digital technology use · Psychological distress · Well-Being · Mental health

## Introduction

Depressive symptoms have increased among adolescents in recent years (Keyes et al., 2019), prompting fears that new media such as social media and smartphones is a root cause (Twenge et al., 2018). Most studies reporting associations between poorer mental health and digital technology use rely on cross-sectional data, which hampers the ability to understand directionality of effects (as reviewed by Odgers & Jensen, 2020) and highlights the need for studies that apply

longitudinal designs and more nuanced and rigorous analytic approaches. Moreover, many studies examine adolescents' reports of digital technology *use*, whereas their perceptions of how digital technology is impairing daily life activities is often more strongly associated with well-being outcomes (Marino, 2018). As such, there is a need to further understand how adolescents' perceptions of digital technological impairment change over time and how these perceptions relate to adolescents' mental health. This study advances prior research by integrating longitudinal assessments of adolescents' perceived digital technological impairment and psychological distress, with the prospective repeated assessments allowing the testing of (1) how adolescents' changes in perceived impairment related to changes in psychological distress over time, and (2) if there were within-person dynamic linkages between perceived technological impairment and psychological distress.

## Disentangling Digital Technology Use from Digital Technological Impairment

Digital technology use is often defined as adolescents' engagement with mobile phones and the online world.

**Supplementary information** The online version contains supplementary material available at <https://doi.org/10.1007/s10964-022-01679-1>.

✉ Kaitlyn Burnell  
burnellk@unc.edu

<sup>1</sup> Duke University, Durham, NC, USA

<sup>2</sup> University of California Irvine, Irvine CA, USA

<sup>3</sup> Present address: University of North Carolina at Chapel Hill, 235 E Cameron Ave, Chapel Hill, NC, USA

Meta-analytic evidence suggests weak to null associations between digital technology use and poorer well-being (Ferguson et al., 2022). Researchers have argued that instead of examining associations between well-being and general digital technology use, specific components of digital technology use should be investigated (Odgers & Jensen, 2020), particularly as self-reported measures of digital technology use are often only weakly correlated with objective assessments (Parry et al., 2021). Prior research with this sample has demonstrated few robust linkages between digital technology use and adolescents' mental health symptoms, including when the data are examined cross-sectionally (George et al., 2020) and repeatedly in daily life (Jensen et al., 2019). This study turns away from measuring hours and minutes spent on smartphones and social media, and towards adolescents' perceptions of whether and how their time spent with digital technology is impairing their health and social relationships.

The degree to which digital technology use is perceived as problematic is distinct from reported high levels of digital technology use (Marino, 2018). High levels of digital technology use is not necessarily synonymous with this use being problematic or impairing, as many adolescents engage in high levels of digital technology use without reporting that this use is problematic (Boer et al., 2022a). Adolescents engage with digital technologies for hours each day (Rideout et al., 2022), and such use can be classified as normative for contemporary adolescents. Adolescents who engage very little with digital technologies may be socially distant from their peers (Moreno & Jolliff, 2022), as digital technologies such as social media may be a primary avenue for adolescents' social lives to unfold (boyd, 2014). Because of this, the lack of or very low digital technology use may serve as a marker of deficits in psychosocial functioning. Overall, it may be more fruitful to study how elements of digital technology use, rather than sheer frequency, relate to psychological functioning. To this end, one body of research targets perceptions of how digital technology interferes with daily life.

Numerous studies targeting adolescents have examined problematic digital technology use, also conceptualized as digital technology dependence or addiction. However, past research is often plagued by theoretical, conceptual, and methodological inconsistencies and weaknesses (e.g., Lee et al., 2017). Although claims of how digital technologies are addictive are common, researchers have cautioned against the application of an addiction framework (e.g., Panova & Carbonell, 2018) especially given the lack of evidence that digital technology use shares the same addictive properties as disorders that are widely accepted as addictions (e.g., alcohol use disorder). A popular view is that digital technology is harmful to adolescents (Lanette et al., 2018). As described above, although most studies do

not find robust evidence for harm, it is nonetheless possible that the widespread belief that digital technology use is harmful may amplify associations between digital technology use and well-being. For example, for Facebook users, associations between greater Facebook use and poorer well-being are observed only for those who believe Facebook is bad for well-being (Ernala et al., 2022). Thus, it is important to examine the extent to which adolescents perceive that digital technology is interfering with daily life activities, and how these perceptions relate to well-being. The following section describes the importance of adapting a perceptions framework, how each of aspect of perceived impairment was measured, and the motivation for doing so.

### The Measurement of Perceived Technological Impairment

In the current research, technological impairment was operationalized by the degree to which adolescents perceived that digital technology affected their daily life, versus measuring objectively-recorded impacts of digital technology on their daily lives. As an example, adolescents were asked the extent to which they were short of sleep due to being on their phone or the internet late at night. The biological changes accompanying adolescence are associated with a delay in sleep onset (Hagenauer et al., 2009), which may be exacerbated by device use (Alonzo et al., 2021). For example, adolescents may stay up late using devices instead of going to sleep, wake up in the middle of the night to the sound of notifications, or experience heightened issues with falling asleep due to exposure to psychophysiological arousing digital content (LeBourgeois et al., 2017). In the absence of objective data, there is a reliance on how adolescents perceive these issues, rather than calculating the extent to which sleep-impairing technology use occurs (e.g., how often an adolescent receives a notification overnight, and if the receipt of this notification is associated with objectively-measured sleep disruption). Moreover, one adolescent who scrolls through social media or watches videos before bed may perceive that they are short of sleep because of these activities; another adolescent who engages in the same activities may perceive that they are not short of sleep from these activities as they consider them to be a part of a normal nightly routine. In turn, these differences in perceptions (versus actual use) may have differential consequences for observed associations with mental health indicators, as studies have repeatedly shown that perceptions of digital technology use being problematic tend to be more strongly associated with mental health than general use (Marino, 2018).

In addition to sleep, the measure of perceived technological impairment included perceptions of attachment and dependence on digital technology, interference on social

relationships, and use of digital technologies to relieve negative emotions. These aspects of perceived technological impairment may be important to study for adolescents in particular. Many affordances of digital technology are developmentally attractive to adolescents (Nesi et al., 2018), and these affordances may both enhance and detract from adolescents' normative developmental experiences. One key experience is the facilitation of peer connections and romantic relationships (Brown & Larson, 2009). Digital technologies are used as a tool to communicate with both peers and romantic partners (Ehrenreich et al., 2020), and adolescents report that digital technologies are a critical lifeline to their friends (boyd, 2014). Because of the utility of digital technologies to fulfill this central developmental task, adolescents may face increasing attachment to their devices. There is also concern that digital technology use is displacing the in-person time that adolescents would spend with these individuals (boyd, 2014). This includes opting to engage with digital technologies in lieu of in-person connection (Vilhelmson et al., 2018), and/or engaging with digital technologies while in-person with others (McDaniel, 2015). The current study assessed these perceived technology-induced impairments by measuring adolescents' reported difficulties ceasing digital technology use, irritability when digital technology cannot be used, and choices to use digital technologies instead of engaging in daily obligations or spending time with others. Finally, adolescence is a period of navigating numerous biological, academic, and socioemotional changes, which in turn coincide with increases in depressive symptoms, particularly for girls (Kouros & Garber, 2014). This prompts a need to develop and practice healthy coping strategies (Zimmer-Gembeck & Skinner, 2011), and adolescents may be particularly likely to turn to the media as a coping strategy (Eschenbeck et al., 2018), which in turn can have mixed results on well-being (Wolfers & Schneider, 2021).

Previous research with this sample indicates that nearly all adolescents perceive some degree of technological impairment (George et al., 2020), and, in line with other studies (e.g., Raudsepp, 2019), perceived technological impairment increases over adolescence (Burnell et al., 2022). It remains unclear to what extent initial levels, rates of change, or within-person changes in perceived technological impairment are linked to mental health symptoms. This longitudinal prospective design was leveraged to test how adolescents' perceived technological impairment was related to psychological distress both concurrently and across adolescence. Understanding whether adolescents' perceived technological impairment and levels of psychological distress are simply co-occurring versus related dynamically across this period represents an important step in understanding what the documented high levels of perceived impairment may mean for adolescents' well-being.

## Is Adolescents' Perceived Technological Impairment Associated with Their Well-being?

Digital technology use that is perceived as problematic is more strongly linked to poorer well-being than are more basic reports of digital technology use and time spent on screens and devices (Davidson et al., 2022). The current research examined well-being in the context of psychological distress, defined as adolescents' depressive and anxiety symptoms over the past month. Over time, there may be bidirectional linkages between perceived technological impairment and psychological distress. Perceived impairment may signal poorer well-being, in which those with greater depressive and anxiety symptoms may be more likely to turn to digital technology to assuage these problems (Kardefelt-Winther, 2014). Thus, greater psychological distress may be prospectively linked with greater perceived technological impairment. On the other hand, those who report greater perceived impairment may have experiences that have known linkages with poorer well-being (e.g., harmful social comparisons; Boer et al., 2022b), and/or displace activities and behaviors that are known to enhance well-being. For example, an adolescent who reports using digital technology instead of connecting with others in-person may not receive the benefits of in-person social connection (Vilhelmson et al., 2018). Therefore, greater perceived technological impairment may be prospectively linked with greater psychological distress. Longitudinal evidence for bidirectional associations has been mixed. Although there is some support that problematic digital technology use both predicts and is predicted by poorer well-being (e.g., Gámez-Gaudix, 2014), there is also evidence for a unidirectional association, with problematic digital technology use prospectively associated with poorer well-being (e.g., Ciarrochi et al., 2016).

The current research utilized latent curve modeling to assess both trajectories of, and associations between, adolescents' perceived technological impairment and psychological distress. Latent curve models with structured residuals (Curran et al., 2014) have the advantage of separating between-person associations (as modeled by trajectories of impairment and distress) from within-person associations (as modeled by cross-lagged associations of impairment and distress). Since problematic digital technology use (Raudsepp, 2019) and internalizing problems such as depressive symptoms (Kouros & Garber, 2014) tend to increase over adolescence, simultaneously modeling the trajectories of perceived technological impairment and psychological distress can determine the extent to which these changes are interrelated. Indeed, support for these associations has been found (e.g., Raudsepp, 2019). However, positive interrelations between trajectories of impairment and distress do not necessarily indicate that an adolescent who reports greater perceived impairment at one wave relative to their underlying trajectory will also report

increases in psychological distress at the next wave (within-person associations; see also Fisher et al., 2018).

Increasingly, studies demonstrate that associations between general digital technology frequency and poorer well-being are limited to the between-person level, with within-person linkages that are weak (Orben et al., 2019), null (Coyne et al., 2020) or highly heterogeneous (Valkenburg et al., 2021). Less research has distinguished within- from between-person associations for problematic digital technology use. There is evidence from large studies among adolescents of within-person associations in which greater problematic use relative to one's average is associated with poorer well-being (but not vice versa; e.g., Boer et al. 2021); however, support is not universal (Takahashi et al., 2022). These mixed associations point to a need to understand interrelations more fully between changes in adolescents' perceived technological impairment and psychological distress, with special attention to distinguish between- from within-person associations. The current research tested how the trajectories of perceived technological impairment and psychological distress may be inter-related (between-person associations) and if there were significant cross-lagged associations between perceived impairment and distress (within-person associations).

### Age and Sex as Moderators

Developmental period may relate to how adolescents experience digital technologies (e.g., Orben et al., 2022). Several properties of digital technologies may result in greater perceived impairment for younger adolescents (aged 9–12) compared to middle adolescents (aged 13–15). For example, younger adolescents have fewer digital skills (Livingstone & Helsper, 2010) which may increase their chances of encountering problematic and risky content. Moreover, earlier adolescents demonstrate lower inhibitory abilities than later adolescents (Atherton et al., 2020), and may have greater difficulty regulating their technology use. On the other hand, mid-adolescents place greater importance on peer status (LaFontana & Cillessen, 2010), and therefore may be more sensitive to quantifiable indices of peer approval (Nesi et al., 2018), and have greater challenges disengaging from use. Moreover, although greater use does not equate with greater impairment, digital media use increases with age (Rideout et al., 2022). For some adolescents, this greater use may result in the displacement of numerous important activities (e.g., sleep) which in turn may increase perceptions of impairment. Potential differences by age group were examined as exploratory.

Girls have reported stronger negative emotional experiences to digital content compared to boys (Nesi et al., 2021). Girls may be more vulnerable to social comparison and feedback seeking processes (Nesi & Prinstein, 2015),

online interpersonal conflict (Marwick & boyd, 2014), and cybervictimization (Baldry et al., 2015). Together, these results suggest that girls may perceive greater technological impairment, which is supported by previous studies examining problematic digital technology use (Marino et al., 2018).

### Current Study

To advance the mainly cross-sectional research examining linkages between adolescents' perceived technological impairment and problematic use and mental health, the following research questions were posited. First, were adolescents with higher levels of perceived technological impairment more likely to report higher levels of psychological distress, both at the between-person level (associations between trajectories) and the within-person level (cross-lagged associations)? By disentangling between- from within-person associations, it can be tested if adolescents who reported greater perceived technological impairment relative to their underlying trajectory reported greater psychological distress at the subsequent wave. Second, did adolescents' trajectories and associations between perceived technological impairment and psychological distress differ by age group and/or sex? By examining moderation by age group and gender, it can be determined if linkages vary based on key individual differences. It was expected girls would report greater perceived technological impairment and increase more steeply in their perceptions of impairment over time. Age-related differences in associations were treated as exploratory.

### Methods

#### Participants

A representative sample of 2104 adolescents was drawn from North Carolina Public Schools using administrative data from the North Carolina Department of Public Instruction. At baseline (Wave 1, 2015), participants were in Grades 5–8 (ages 9–15,  $M_{\text{age}} = 12.36$ ,  $SD_{\text{age}} = 1.12$ ; 52% girls). Adolescents were representative of the larger public school statewide population in terms of economic disadvantage, sex, and ethnicity (Rivenbark et al., 2019). The racial/ethnic distribution was 52% Non-Hispanic White, 23% Non-Hispanic Black, 15% Hispanic, and 10% Multiracial/Other. Fifty-six percent of participants were classified as being economically disadvantaged at least once according to their annual administrative records dating back to the third grade. Participants were initially recruited via telephone and completed the baseline surveys over the phone if their parent(s) consented

and they assented to the study. Consent procedures and surveys for the subsequent waves were conducted online. At each stage of the study, participants completed a battery of surveys, including those utilized in the current research. All study procedures were approved by the Duke University Institutional Review Board.

Seven hundred and thirty-one adolescents participated in Wave 2 (2017), 702 participated in Wave 3 (2018), and 891 participated in Wave 4 (2020; 486 participated in all four waves). To assess if the population representativeness of the original sample on key demographic, psychosocial, and academic variables changed due to participant dropout in later waves, differences between adolescents who completed only the baseline survey ( $n = 1006$ ) and those who completed at least two waves of the study ( $n = 1098$ ) are reported in Table 1. Those who completed two or more waves of the study were more likely to be younger, female, white (compared to Hispanic), not economically disadvantaged, and higher academically achieving. Full Information Maximum Likelihood estimation was used to retain the full sample of  $N = 2104$  in the analyses and to adjust for missingness due to bias in estimation from selective attrition over the course of the study.

## Measures

### Perceived technological impairment

Perceived technological impairment was measured based on adolescents' reports of six items adapted from previous

research (Demetrovics et al., 2008; Morahan-Martin & Schumacher, 2000; Young, 1999) that assessed how they felt technology may be impairing aspects of their daily life (see Table 2 for full item list). Items were answered using a 0–2 scale (0 = Never, 2 = Often;  $\alpha$ 's = 0.70–0.80). Standardized loadings were consistently satisfactory across all four waves (all loadings above 0.40; average loading = 0.59).

### Psychological distress

Psychological distress was measured based on adolescents' responses to the 6-item Kessler Psychological Distress Scale (Kessler et al., 2002), which assesses a range of symptoms relevant to depressed mood, motor agitation, fatigue, worthless guilt, and anxiety. Items were answered using a 0–4 scale (0 = None of the time, 4 = All of the time), and a sample item includes, "During the past 30 days, about how often did you feel worthless?" ( $\alpha$ 's = 0.65–0.87). Previous research has demonstrated that this measure is highly valid in measuring emotional disturbance in adolescence (Green et al., 2010).

### Moderators

Participants reported their sex and age (verified by birthdate) at baseline.

### Variables for attrition analyses

Administrative data were collected for family economic disadvantage, math test scores, and reading test scores.

**Table 1** Sample characteristics

	Total sample ( $N = 2104$ )	Baseline only ( $n = 1006$ )	Two plus waves ( $n = 1098$ )	$p$
Sex	52% female	49% female	55% female	0.007
Race	52% White	46% White	56% White	<0.001
	23% Black	24% Black	21% Black	
	15% Hispanic	18% Hispanic	12% Hispanic	
	10% Multi/Other	11% Multi/Other	9% Multi/Other	
Disadvantage	56%	64%	49%	<0.001
Age (Baseline)	12.36 (1.12)	12.43 (1.12)	12.30 (1.12)	0.008
Math achieve (Baseline)	452.76 (10.30)	450.79 (10.58)	454.52 (9.72)	<0.001
Read achieve (Baseline)	456.56 (11.43)	454.59 (11.79)	458.33 (10.82)	<0.001
Neigh quintile (Baseline)	2.97 (1.41)	2.79 (1.37)	3.10 (1.42)	<0.001
Distress (Baseline)	1.88 (0.61)	1.91 (0.63)	1.86 (0.59)	0.080
Ext problems (Baseline)	0.13 (0.22)	0.15 (0.24)	0.12 (0.20)	0.008
Impairment (Baseline)	0.63 (0.42)	0.64 (0.42)	0.63 (0.42)	0.330

$p$ -value reflects differences between the baseline only sample and those who completed two or more waves of the study

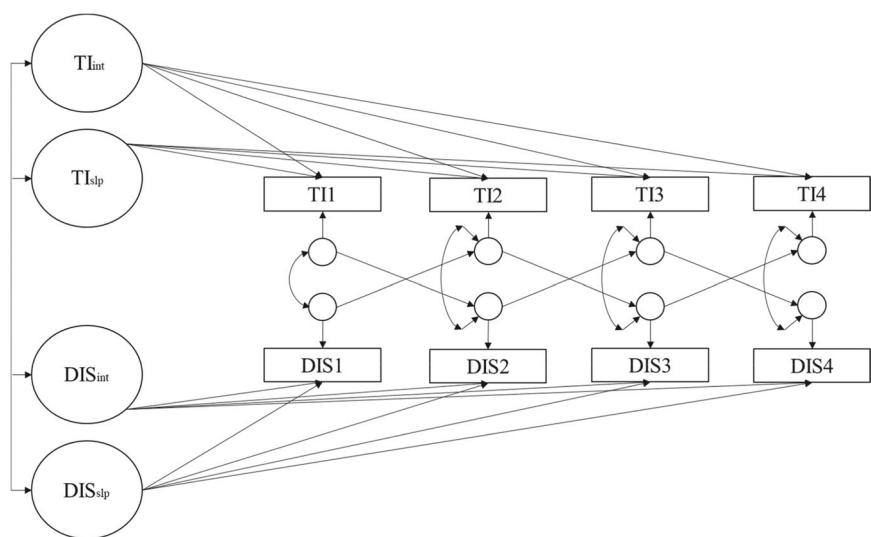

**Table 2** Item endorsement by wave

Wave	Endorsement			
	1	2	3	4
1. Do you find it difficult to stop using technology, such as the internet or your mobile phone, once you start?	77%	81%	81%	87%
2. Are you short of sleep due to being on your phone or the internet late at night?	53%	60%	61%	72%
3. Do you neglect your daily obligations (school, family, friends) because you are using technology?	43%	45%	48%	58%
4. Do you feel restless, frustrated, or irritated when you cannot access the internet or check your mobile phone?	53%	62%	62%	67%
5. Do you use technology to escape from your sorrow or get relief from negative feelings?	44%	61%	63%	79%
6. Do you choose to spend more time online over going out with others?	36%	47%	52%	54%

Endorsement reflects percentage of participants who answered ‘1’ or ‘2’ on 0–2 response scale at each wave (0 = Never, 1 = Sometimes, 2 = Often)

**Fig. 1** Latent curve model with structured residuals. TI perceived technological impairment, DIS distress, Int intercept, SIp Slope



Family economic disadvantage was assessed from school administrative records beginning in the third grade and going through 2015, which indicated low-income family status based on income verification. Data were available for 2042 adolescents. *Math achievement* test scores were available for 2019 adolescents and *reading achievement* test scores were available for 2020 adolescents. Test scores were from the 2014–2015 school year. *Neighborhood quintile* was classified from census data for 1863 adolescents (1 = Lowest neighborhood income, 5 = Highest neighborhood income). *Externalizing problems* at baseline was assessed with 25 items measuring aggressive and deviant behavior over the past month (e.g., “Thrown something at someone to hurt them”;  $\alpha = 0.87$ ; Miller-Johnson et al., 2004). These variables, in addition to demographic variables, were chosen for attrition analyses in order to obtain a complete profile of critical indicators of known correlates with attrition, including SES (economic disadvantage, neighborhood quintile), academic success (math and test achievement scores), and psychosocial adjustment

(externalizing problems, in addition to internalizing problems as measured via psychological distress).

**Analytic Plan**

Research questions were tested using the latent curve model with structured residuals (Curran et al., 2014), which has the advantage of estimating both between-person (the underlying trajectories of perceived technological impairment and psychological distress) and within-person associations (autoregressive and cross-lagged associations between impairment and distress). Through the modeled trajectories, changes in perceived technological impairment and psychological distress were estimated over time, and tested how these changes, as well as baseline levels, were associated. The within-person associations tested whether adolescents who reported higher levels of perceived technological impairment at one wave were more likely to exhibit elevated psychological distress at the next wave (and vice versa), above and beyond their underlying trajectories of impairment and distress.

Model building followed the guidelines outlined in Curran et al., (2014), and all models were estimated in *Mplus* (Muthén & Muthén, 1998–2017). Intercept-only models for perceived technological impairment and distress were first estimated separately and tested if the addition of a linear slope improved model fit. Model fit was assessed using the cutoff criteria suggested by Hu & Bentler (1999): 0.06 for RMSEA, 0.95 for CFI, and 0.08 for SRMR. To account for unequal intervals between waves, factor loadings in the growth models were fixed as follows: Wave 1 = 0, Wave 2 = 2, Wave 3 = 3, and Wave 4 = 5. Next, autoregressive paths among the residuals were included. Then, models were combined into a single bivariate latent curve model, with covariances between impairment and distress included for all waves. Finally, cross-lagged paths were added (Fig. 1). Chi square difference tests assessed if each subsequent model improved model fit over the previous model. Follow-up models included age group (younger adolescents aged 9–12,  $n = 1145$ ; older adolescents aged 13–15,  $n = 959$ ) and sex (male  $n = 1008$ ; female  $n = 1096$ ) as predictors of the intercepts and slopes<sup>1</sup> of perceived technological impairment and psychological distress (Curran et al., 2014). For the purposes of transparency, please note that all results of the conducted analyses relevant to the current research are reported. No data exclusions were made and all relevant measures are noted.

## Results

Participant endorsement of each perceived technological impairment item is in Table 2. Descriptively, a greater proportion of adolescents endorsed each item across time. The percentage point increase in item endorsement from Wave 1 to Wave 4 was relatively consistent across items (ranging from an increase of 10–19 percentage points), but there was a particularly sharp increase in reports of using digital technology for coping (increasing from 44% of participants at Wave 1 to 79% of participants at Wave 4). To ensure that these results are not based on selective attrition, item endorsement for the 486 adolescents who participated in all four waves was confirmed to be nearly identical (see supplement). Additionally, perceived technological impairment item endorsement was examined by age, in which the proportion of adolescents between ages 10 to 19 who endorsed each item was examined regardless of wave (ages 9 and 20 were omitted due to low sample sizes).

<sup>1</sup> Multiple group models tested if within-person associations varied by age group and sex. There was no evidence of moderation; however, there were numerous convergence issues and results should be interpreted cautiously.

Full results are in the supplement. To summarize, item endorsements increased as adolescents aged for all six items. Sleep difficulties from digital technology and using digital technology to cope were particularly likely to increase. For example, sleep difficulties from digital technology increased fairly sharply from age 10 (endorsed by 37% of participants) to age 14 (endorsed by 62% of participants), with a slower increase observed through age 19. Similarly, using digital technology to cope increased fairly sharply from age 10 (endorsed by 43% of participants) to age 15 (endorsed by 67% of participants), and stayed somewhat level through late adolescence.

Descriptive statistics and correlations are reported in Table 3. Moderate-to-strong cross-sectional associations were observed between impairment and distress at all waves. Model fit results are in Table 4. Adding within-person cross-lagged associations to the combined bivariate latent curve model did not significantly improve model fit, and the most parsimonious model was the bivariate latent curve model with the autoregressive paths included and cross-lagged paths excluded. This suggests no evidence of within-person associations. Several between-person associations were observed, as evident by associations among the intercepts and slopes (Table 5).

First, adolescents increased on both their perceived impairment and psychological distress across the five-year period. Adolescents' perceived technological impairment slope ( $\beta = 0.52$ ) and psychological distress slope ( $\beta = 0.66$ ) were both positive and significant, demonstrating increases in both perceived impairment and psychological distress over time. The perceived technological impairment intercept (baseline impairment) and slope (rate of change across the five years) were negatively correlated ( $\beta = -0.56$ ), indicating that adolescents who reported higher perceived impairment at Wave 1 experienced a slower increase in their impairment over time. The intercept and slope for psychological distress were not significantly correlated ( $\beta = -0.11$ ).

Second, adolescents' patterns of change in perceived technological impairment and psychological distress were related to each other across the five-year period. That is, adolescent initial starting points of perceived technological impairment and psychological distress were positively correlated ( $\beta = 0.62$ ), indicating adolescents who reported higher impairment at Wave 1 also reported higher distress. Moreover, adolescents' perceived technological impairment intercept and psychological distress slope were negatively correlated ( $\beta = -0.10$ ), indicating that adolescents who reported higher impairment at Wave 1 reported less steep increases in psychological distress over time. Likewise, the psychological distress intercept and perceived technological impairment slope were negatively correlated ( $\beta = -0.34$ ), indicating that adolescents who reported higher distress at



**Table 3** Correlations and descriptive statistics

	1	2	3	4	5	6	7	8
1. TI1	–							
2. TI2	0.40	–						
3. TI3	0.36	0.57	–					
4. TI4	0.23	0.44	0.50	–				
5. DIS1	0.33	0.20	0.18	0.09	–			
6. DIS2	0.26	0.40	0.26	0.26	0.31	–		
7. DIS3	0.20	0.30	0.36	0.31	0.26	0.61	–	
8. DIS4	0.14	0.22	0.23	0.42	0.18	0.46	0.58	–
<i>M</i>	0.63	0.74	0.75	0.86	1.88	2.16	2.26	2.40
<i>SD</i>	0.42	0.46	0.48	0.45	0.61	0.85	0.89	0.88
% Missing	<0.01%	65%	68%	61%	0%	65%	67%	60%

All correlations are significant at  $p < 0.01$

*TI* perceived technological impairment, *DIS* psychological distress

**Table 4** Changes in model fit

	$\chi^2$	<i>df</i>	$\Delta\chi^2$ ( $\Delta df$ )	Compare	RMSEA	CFI	SRMR
<b>Impairment</b>							
1. Intercept	305.77	8	–	–	0.13	0.48	0.16
2. Intercept with slope <sup>a</sup>	36.92	5	268.85* (3)	2 vs 1	0.06	0.94	0.06
3. Autoregressive <sup>b</sup>	2.28	2	34.64* (3)	3 vs 2	0.01	1.00	0.01
<b>Distress</b>							
4. Intercept	663.33	8	–	–	0.20	0.00	0.26
5. Intercept with slope <sup>c, d</sup>	93.10	5	570.23* (3)	5 vs 4	0.09	0.84	0.08
6. Autoregressive <sup>e</sup>	18.26	2	74.84* (3)	6 vs 5	0.06	0.97	0.04
<b>Combined</b>							
7. Autoregressive only <sup>f</sup>	29.36	12	–	–	0.03	0.99	0.03
8. Cross-Lagged	21.67	6	7.69 (6)	8 vs 7	0.04	0.99	0.02

\* $p < 0.001$  in change of chi square

<sup>a</sup>Constraining the residuals to be equal significantly worsened model fit,  $\Delta\chi^2$  ( $\Delta 3$ ) = 16.38,  $p < 0.001$ ; therefore, a heteroscedastic residual structure was retained

<sup>b</sup>Constraining the autoregressive paths to be equal significantly worsened model fit,  $\Delta\chi^2$  ( $\Delta 2$ ) = 25.11,  $p < 0.001$ ; therefore, paths were allowed to vary

<sup>c</sup>Constraining the residuals to be equal significantly worsened model fit  $\Delta\chi^2$  ( $\Delta 3$ ) = 55.61,  $p < 0.001$ ; therefore, a heteroscedastic residual structure was retained

<sup>d</sup>Because model fit remained inadequate, a follow-up model adding a quadratic term was run. This model fit well,  $\chi^2$  (1) = 0.01, RMSEA = 0.00, CFI = 1.00, SRMR = 0.001. An inspection of the means indicated that although psychological distress increased across all waves, this increase was especially steep between Waves 1 and 2. For simplicity, follow-up models are run with the quadratic term omitted

<sup>e</sup>Constraining the autoregressive paths to be equal significantly worsened model fit,  $\Delta\chi^2$  ( $\Delta 2$ ) = 21.52,  $p < 0.001$ ; therefore, paths were allowed to vary

<sup>f</sup>Constraining covariances to be equal significantly worsened model fit,  $\Delta\chi^2$  ( $\Delta 3$ ) = 22.21,  $p < 0.001$ ; therefore, covariances were allowed to vary

Wave 1 reported less steep increases in their impairment over time. Finally, the perceived technological impairment and psychological distress slopes were positively correlated ( $\beta = 0.45$ ), indicating that, over time, as perceived

technological impairment increased, psychological distress also increased. Collectively, these results provide evidence for between-person associations between adolescents' perceived impairment and psychological distress.

**Table 5** Results from latent curve model with structured residuals

	<i>b</i>	<i>SE</i>	<i>p</i>	$\beta$
TI Intercept mean	0.64	0.01	<0.001	–
TI Intercept variance	0.13	0.03	<0.001	–
TI Slope mean	0.05	0.003	<0.001	0.52
TI Slope variance	0.01	0.002	<0.001	–
DIS Intercept mean	1.89	0.01	<0.001	–
DIS Intercept variance	0.14	0.10	0.163	–
DIS Slope mean	0.11	0.01	<0.001	0.66
DIS Slope variance	0.03	0.01	<0.001	–
TI Intercept with TI slope	–0.02	0.01	0.001	–0.56
TI Intercept with DIS intercept	0.08	0.01	<0.001	0.62
TI Intercept with DIS slope	–0.01	0.003	0.047	–0.10
TI Slope with DIS intercept	–0.01	0.003	<0.001	–0.34
TI Slope with DIS slope	0.01	0.001	<0.001	0.45
DIS Intercept with DIS slope	–0.01	0.02	0.744	–0.11
TI1 to TI2	–0.52	0.67	0.436	–0.33
TI2 to TI3	0.29	0.06	<0.001	0.27
TI3 to TI4	0.04	0.11	0.751	0.06
DIS1 to DIS2	0.14	0.20	0.490	0.09
DIS2 to DIS3	0.38	0.06	<0.001	0.40
DIS3 to DIS4	–0.12	0.20	0.532	–0.54

Results are from Model 7 depicted in Table 4, with covariances between impairment and distress included but cross-lagged paths excluded

TI perceived technological impairment, DIS psychological distress

Very little evidence was found for within-person associations. Only two significant within-person autoregressive paths were found (between Waves 2 and 3). That is, after accounting for adolescents' underlying trajectories of perceived technological impairment and psychological distress, Wave 2 impairment was associated with greater Wave 3 impairment ( $\beta = 0.27$ ), and Wave 2 distress was associated with greater Wave 3 distress ( $\beta = 0.40$ ). No associations emerged between Waves 1 and 2, and Waves 3 and 4. As the addition of the cross-lagged paths did not significantly improve model fit, there was no evidence of longitudinal within-person associations between perceived technological impairment and psychological distress<sup>2</sup>.

<sup>2</sup> A sensitivity analysis limiting the sample to the 486 participants who completed all four waves was conducted, with the same general pattern of results observed. The addition of cross-lagged paths did not significantly improve model fit, suggesting no evidence of within-person associations. The between-person associations among the intercepts and slopes were generally the same, except that the association between the impairment intercept and distress slope was no longer significant ( $p = .173$ ).

## Age Group and Sex

Age group<sup>3</sup> was significantly associated with the perceived technological impairment intercept ( $b = 0.12$ ,  $SE = 0.02$ ,  $p < 0.001$ ,  $\beta = 0.16$ ) and slope ( $b = -0.02$ ,  $SE = 0.01$ ,  $p = 0.001$ ,  $\beta = -0.13$ ). Older adolescents reported higher perceived technological impairment at baseline but increased less steeply in their perceived impairment over time compared to younger adolescents. The association between age group and the psychological distress intercept did not reach conventional levels of significance ( $b = 0.05$ ,  $SE = 0.03$ ,  $p = 0.052$ ,  $\beta = 0.07$ ), and indicated that older adolescents tended to report higher distress at baseline. Age group was not associated with the psychological distress slope ( $b = -0.01$ ,  $SE = 0.01$ ,  $p = 0.323$ ,  $\beta = -0.04$ ).

Sex<sup>4</sup> was significantly associated with the perceived impairment intercept ( $b = 0.06$ ,  $SE = 0.02$ ,  $p = 0.002$ ,  $\beta = 0.08$ ); the association with the slope did not reach conventional levels of significance ( $b = 0.01$ ,  $SE = 0.01$ ,  $p = 0.077$ ,  $\beta = 0.07$ ). Females reported higher perceived impairment at baseline and tended to increase in their impairment more steeply over time compared to males. Sex was also significantly associated with the psychological distress intercept ( $b = 0.10$ ,  $SE = 0.03$ ,  $p < 0.001$ ,  $\beta = 0.15$ ) and slope ( $b = 0.05$ ,  $SE = 0.01$ ,  $p < 0.001$ ,  $\beta = 0.17$ ). Females reported higher distress at baseline and increased more steeply in distress over time.

## Discussion

Although observed associations between adolescents' digital technology use and well-being are small (Ivie et al., 2020), a pervasive narrative exists that digital technologies are harming adolescents' mental health (Lanette et al., 2018). Most adolescents perceive that digital technology impairs their daily life to some degree (George et al., 2020),

<sup>3</sup> A sensitivity analysis limiting the sample to those who completed all four waves indicated the same pattern of results, except the marginal association with the distress intercept was now significant ( $p = .046$ ). A sensitivity analysis in which age was included as a continuous predictor yielded the same pattern of results, except that the marginal association with the distress intercept was not significant ( $p = .129$ ).

<sup>4</sup> A sensitivity analysis limiting the sample to those who completed all four waves indicated a slightly different pattern of results, in which the associations with the impairment intercept ( $p = 0.539$ ) and distress intercept ( $p = 0.430$ ) were no longer significant. An examination of the means indicating that girls with higher baseline impairment and distress were more likely to be lost over the course of the study, suggesting that limiting the analysis to those who completed all four waves may be omitting girls with a more maladaptive psychosocial profile at baseline, in which they report higher baseline impairment and distress. Interpretation of the results with the full sample is recommended, as the intercepts assess Wave 1 impairment and distress, and data were complete at this wave.

and it is important to examine how adolescents' perceived impairments link with mental health. This study demonstrated that adolescents' perceived digital technological impairment and psychological distress increased over the course of adolescence, and that these increases co-occurred. However, there was little evidence that greater perceived digital technological impairment at one wave relative to one's underlying trajectory was subsequently linked to increased psychological distress at the next wave (and vice versa).

### Adolescents' Perceived Technological Impairment and Psychological Distress

Adolescents with higher baseline perceived technological impairment reported higher baseline psychological distress, in line with past support for an association between perceived digital technology impairment and poorer mental health (Marino et al., 2018). Moreover, as seen in past research (e.g., Raudsepp, 2019), perceived impairment and distress both increased across adolescence, and these increases co-occurred. This represents a between-person association: adolescents who increased more steeply in their perceived impairment over time also increased more steeply in their psychological distress. As adolescents' use of digital technology grows with age, they may be more likely to perceive that this use is impairing their daily life. Likewise, increases in psychological distress over adolescence are well-established (Kouros & Garber, 2014). Adolescents who see particularly steep increases in their psychological distress may also coincidentally perceive greater impairment from their digital technology use, particularly if this use is used for coping or escapism. Importantly, both perceived technological impairment and psychological distress may be compounded by adolescents' internalization of societal views and expectations of the adolescent developmental period as being one of emotional turmoil and heightened risk for a host of negative outcomes and behaviors (Hollenstein & Loughheed, 2013). In addition, the widely held societal belief that adolescents are "addicted" to technology may itself have negative impacts on development (Lanette et al., 2018). It would be fruitful for future research to determine the role, if any, that internalization of beliefs about the adolescent developmental period and digital technology use may play in the relations between perceived technological impairment and psychological functioning.

Endorsement of all measured perceived technological items increased over time. Endorsement of difficulties to cease digital technology use once starting was particularly high by Wave 4, with nearly all participants endorsing some degree of difficulty. Digital technologies are often well matched to adolescents' developmental needs, such as peer communication (Ehrenreich et al., 2020). Thus, adolescents

may find it difficult to disengage from use due to these developmentally relevant affordances (Nesi et al., 2018). Items pertaining to daily life obligations and social gatherings were endorsed by fewer participants, which could indicate a greater ability to disengage from use when adolescents are able to fulfill tasks such as peer social gatherings in-person (boyd, 2014). However, a sizable number of adolescents (approximately half) endorsed these items by Wave 4. These items do not necessarily distinguish peer gatherings from other gatherings (e.g., family time, which may be more vulnerable to technology interference). Future research can examine the extent digital technologies displace time spent in-person with peers, hallmark of adolescence (Brown & Larson, 2009), compared to others.

Perceptions of sleep impairment from digital technology notably increased throughout adolescence. There are widespread concerns of how digital device use may be impairing sleep (Alonzo et al., 2021), especially during a developmental period that is known to be associated with sleep deficits (Hagenauer et al., 2009). Importantly, these changes co-occurred with known biological and societal factors that impact sleep, including delays in sleep onset due to puberty and earlier school start times in high school (Hagenauer et al., 2009). It is possible that adolescent reports of sleep impairments from digital technology may be in part confounded by sleep impairments that may normatively occur due to ongoing developmentally-relevant changes during adolescence. Future research is required to attempt to disentangle these factors.

There was a sharp increase in reports of using digital technology for coping, particularly between ages 10 and 15. This jump could reflect the well-documented increases in mental health problems across adolescence (Kouros & Garber, 2014), and how increasing stressors that accompany adolescence facilitate the development of various coping strategies (Zimmer-Gembeck & Skinner, 2011). Adolescents can utilize digital technologies as an alternative tool to cope with ongoing stressors in their daily lives (Elmquist & McLaughlin, 2017). For example, texting friends can reduce stress after experiencing a stressful event (Yau et al. 2021). However, there is also fear that using digital technologies to cope may be a maladaptive strategy, particularly if a heavy reliance on this strategy replaces existing "healthier" coping strategies (Wolfers & Schneider, 2021). Future research should test what types of digital technology use, and under what conditions, may manifest as adaptive versus maladaptive strategies. For example, it may be useful to test when digital technology use may be associated with avoidant coping (Panova & Lleras, 2016), which in turn may result in daily life impairments. It may also be fruitful to examine specific digital technology behaviors that individuals may turn to for coping, such as turning to videos or advice forums for help to cope (Weinstein et al., 2021), as

well as the degree to which digital technology is used to cope, as using technology to cope at moderate levels may be more effective than heavy levels or not at all (Modecki et al., 2022).

As with many measures assessing problematic digital technology use (Davidson et al., 2022), most items assessing perceived technological impairment measure some existing degree of psychological problems. For example, items pertaining to known correlates with poorer mental health were included, including lower social connectedness (Jose et al., 2012) and sleep problems (Vermeulen et al., 2021). The coping item assumes that an adolescent is already experiencing some degree of negative emotions. The between-person finding of how perceived technological impairment and psychological distress both increased and co-occurred across adolescence cannot attest to the directionality of these associations. On the one hand, adolescents who are already experiencing this existing degree of these psychological problems may be more likely to report greater perceived technological impairment. For instance, adolescents who already are experiencing psychological distress may also be experiencing sleep difficulties and turn to digital technology when finding it hard to sleep. This may conflate their reports of reporting on sleep problems due to digital technology use. On the other hand, adolescents who are especially attached to their digital devices may struggle to disconnect before sleep, resulting in sleep problems which consequently link to greater psychological distress.

Within-person cross-lagged associations can disentangle directionality and attest to these possible linkages. Critically, there was no evidence of longitudinal within-person associations between perceived technological impairment and psychological distress. This indicates that adolescents who reported greater perceived technological impairment relative to their underlying trajectory at one wave did not necessarily report greater psychological distress at the next wave, and vice versa. This is counter to previous evidence suggesting that greater problematic digital technology use and poorer well-being are longitudinally linked (e.g., Ciarrochi et al., 2016). These inconsistencies could be due to previous studies failing to distinguish between- from within-person associations. Indeed, a recent study found similar support for between-person, but not within-person, associations among problematic internet use and depressive symptoms (Takahashi et al., 2022). Once underlying increases in perceived impairment and psychological distress are taken into account, associations with poorer well-being may disappear.

### Moderation by Age Group and Sex

Older adolescents reported higher perceived technological impairment at baseline but increased less steeply in their

perceived impairment over time. As youth transition through adolescence, they engage in greater digital technology use (Rideout et al., 2022) and may find the affordances of digital technologies more developmentally attractive (Nesi et al., 2018). Older adolescents may have greater difficulty disengaging from use, resulting in increased perceptions of impairment. Since these adolescents start higher in their perceived impairment, they may have less “room” for perception increases.

Additionally, girls reported higher perceived technological impairment at baseline, in line with past research finding that girls may encounter greater challenges in digital technology use, such as greater harmful social comparisons (e.g., Nesi & Prinstein, 2015) or cybervictimization (e.g., Baldry et al., 2015). Girls also reported higher psychological distress at baseline and increased more steeply in their distress over time, in accord with findings that girls report greater mental health problems such as depressive symptoms and increase more in these symptoms over time (Kouros & Garber, 2014).

### Limitations

Several limitations must be considered. First, the sample was affected by attrition, with diverse participants more likely to be lost. Second, only one facet of digital technology was assessed, amidst ongoing debate of digital technology measurement issues (Parry et al., 2021), particularly in terms of problematic digital technology use (Panova & Carbonell, 2018). Future research should collect objective measures of various types of digital technology use (e.g., social media, smartphone, gaming), to examine potential differences in associations with well-being. Third, the fourth wave of the study took place at the start of the COVID-19 pandemic, when digital technology use rapidly shifted (e.g., Ellis et al., 2020). Wave 4 indicators of perceived impairment and distress could in part be due to reactions to the pandemic. An analysis of perceived impairment item endorsement by age (see supplement) indicates that increases in impairment for many items were more prominent in the transition from early-to-mid adolescence, in which data were almost entirely collected before the pandemic. Adolescents aged 17, 18 and 19 were primarily featured in Wave 4, and results indicated that item endorsement was not widely different from endorsement at ages 15 and 16 for most items. Fourth, the intervals between waves were unequal and relatively far apart; future research should employ shorter intervals to test possible timing differences.

### Conclusion

Studies utilizing longitudinal designs disentangling between- from within-person associations are needed to better

understand associations among perceived technological impairment and psychological distress. This study found that although increases in perceived technological impairment co-occurred with increases in psychological distress (indicating a between-person association), there was no evidence of within-person associations. The lack of within-person associations must be emphasized: once the underlying trajectories of impairment and distress are taken into account, there is no evidence that adolescents who report elevations in their perceived technological impairment are more likely to report elevations in future psychological distress (or vice versa). This suggests caution is needed regarding the cause-and-effect narrative surrounding adolescents' digital technology use and their well-being (Orben et al., 2019). Parents, teachers, and policymakers should not necessarily treat digital technology use as a monolithic evil that is harming adolescents' mental health; rather, adolescents' unique use of digital technologies should be considered, and the extent to which this use may be impairing individual daily lives. Additionally, the in-depth item analysis by age indicates that early-to-mid adolescence may be a particularly critical time for patterns of impairment to form, with several perceptions increasing more steeply during this developmental period. Parents and teachers of adolescents in this age group can be aware of the vulnerability that this period may hold, and create rules to help curtail the development of problematic types of use (e.g., restricting digital technology use before bed; discussing if and when using digital technology for coping may be a healthy strategy). In a similar vein, moderation by sex suggests that girls may be more susceptible to perceptions of impairment than boys, indicating that adults may exercise greater caution in the formation of adolescent girls' digital technology habits and possible accompanying impairments. Overall, although future research employing rigorous methodologies is needed, this multi-year study demonstrates complexity in the relations in perceptions of technological impairment and psychological distress, and that caution is needed in suggestions that digital technology use is hurting adolescents' mental health.

**Authors' Contributions** K.B. conceived the research questions, conducted statistical analyses and drafted the manuscript; C.L.O. conceived the study, prepared study materials, supervised data collection, assisted with statistical analyses, and provided critical feedback of the manuscript. Both authors read and approved the final manuscript.

**Funding** This research was funded by the National Institute on Drug Abuse, Grant P30DA023026, and a Jacobs Foundation Research Award.

**Data Sharing and Declaration** The manuscript's data are available on Open Science Framework: <https://osf.io/32vry/>.

## Compliance with Ethical Standards

**Conflict of Interest** The authors declare no competing interests.

**Ethical Approval** The study was approved by the Duke University Institutional Review Board. All study procedures were in accordance with the ethical standards of the institutional research committee and with the 1964 Helsinki Declaration and its later amendments or comparable ethical standards.

**Informed Consent** Informed consent/assent was obtained from all individuals included in the study, and parent consent was obtained from all individuals under the age of 18.

## References

- Alonzo, R., Hussain, J., Stranges, S., & Anderson, K. K. (2021). Interplay between social media use, sleep quality, and mental health in youth: a systematic review. *Sleep Medicine Reviews*, 56, 101414. <https://doi.org/10.1016/j.smrv.2020.101414>.
- Atherton, O. E., Lawson, K. M., & Robins, R. W. (2020). The development of effortful control from late childhood to young adulthood. *Journal of Personality and Social Psychology: Personality Processes and Individual Differences*, 119, 417–456. <https://doi.org/10.1037/pspp0000283>.
- Baldry, A. C., Farrington, D. P., & Sorrentino, A. (2015). "Am I at risk of cyberbullying"? A narrative review and conceptual framework for research on risk of cyberbullying and cyber-victimization: the risk and needs assessment approach. *Aggression and Violent Behavior*, 23, 36–51. <https://doi.org/10.1016/j.avb.2015.05.014>.
- Boer, M., Stevens, G. W. J. M., Finkenauer, C., de Looze, M. E. & van den Eijnden, R. J. J. M. (2021). Social media use intensity, social media use problems, and mental health among adolescents: Investigating directionality and mediating processes. *Computers in Human Behavior*, 116, 106645. <https://doi.org/10.1016/j.chb.2020.106645>.
- Boer, M., Stevens, G. W. J. M., Finkenauer, C., & van den Eijnden, R. J. J. M. (2022a). The course of problematic social media use in young adolescents: a latent class growth analysis. *Child Development*, 93, e168–e187. <https://doi.org/10.1111/cdev.13712>.
- Boer, M., Stevens, G. W. J. M., Finkenauer, C., & van den Eijnden, R. J. J. M. (2022b). The complex association between social media use intensity and adolescent wellbeing: a longitudinal investigation of five factors that may affect the association. *Computers in Human Behavior*, 128, 107084. <https://doi.org/10.1016/j.chb.2021.107084>.
- boyd, D. (2014). *It's complicated: the social lives of networked teens*. Yale University Press.
- Brown, B. B., & Larson, J. (2009). Peer relationships in adolescence. In R. M. Lerner & L. Steinberg (Eds.), *Handbook of adolescent psychology: contextual influences on adolescent development* (pp. 74–103). John Wiley & Sons, Inc.
- Burnell, K., Andrade, F. C., & Hoyle, R. H. (2022). Longitudinal and daily associations between adolescent self-control and digital technology use. *Developmental Psychology*. in press
- Ciarrochi, J., Parker, P., Baljinger, S., Marshall, S., Jackson, C., Gloster, A. T., & Heaven, P. (2016). The development of compulsive internet use and mental health: a four-year study of adolescence. *Developmental Psychology*, 52, 272–283. <https://doi.org/10.1037/dev0000070>.
- Coyne, S. M., Rogers, A. A., Zurcher, J. D., Stockdale, L., & Booth, M. (2020). Does time spent using social media impact mental health?: an eight year longitudinal study. *Computers in Human Behavior*, 104, 106160. <https://doi.org/10.1016/j.chb.2019.106160>.
- Curran, P. J., Howard, A. L., Bainter, S. A., Lane, S. T., & McGinley, J. S. (2014). The separation of between-person and within-person



- components of individual change over time: a latent curve model with structured residuals. *Journal of Consulting and Clinical Psychology*, 82, 879–894. <https://doi.org/10.1037/a0035297>.
- Davidson, B. I., Shaw, H., & Ellis, D. A. (2022). Fuzzy constructs in technology usage scales. *Computers in Human Behavior*, 133, 107206. <https://doi.org/10.1016/j.chb.2022.107206>.
- Demetrovics, Z., Szeredi, B., & Rozsa, S. (2008). The three-factor model of Internet addiction: the development of the problematic internet use questionnaire. *Behavior Research Methods*, 40, 563–574. <https://doi.org/10.3758/BRM.40.2.563>.
- Ellis, W. E., Dumas, T. M. & Forbes, L. M. (2020). Physically isolated but socially connected: Psychosocial adjustment and stress among adolescents during the initial COVID-19 crisis. *Canadian Journal of Behavioural Science*, 52, 177–187. <https://doi.org/10.1037/cbs0000215>.
- Ehrenreich, S. E., Beron, K. J., Burnell, K., Meter, D. J., & Underwood, M. K. (2020). How adolescents use text messaging through the day and through their high school years. *Journal of Research on Adolescence*, 30, 521–540. <https://doi.org/10.1111/jora.12541>.
- Elmqvist, D. L., & McLaughlin, C. L. (2017). Social media use among adolescents coping with mental health. *Contemporary School Psychology*, 22, 503–511. <https://doi.org/10.1007/s40688-017-0167-5>.
- Ernala, S. K., Burke, M., Leavitt, A., & Ellison, N. B. (2022). Mindsets matter: how beliefs about facebook moderate the association between time spent and well-being. In *CHI Conference on human factors in computing systems* (pp. 1–13). <https://doi.org/10.1145/3491102.3517569>.
- Eschenbeck, H., Schmid, S., Schröder, I., Wasserfall, N., & Kohlmann, C.-W. (2018). Development of coping strategies from childhood to adolescence. *European Journal of Health Psychology*, 25, 18–30. <https://doi.org/10.1027/2512-8442/a000005>.
- Ferguson, C. J., Kaye, L. K., Branley-Bell, D., Markey, P., Ivory, J. D., Klisanin, D., Elson, M., Smyth, M., Hogg, J. L., McDonnell, D., Nichols, D., Siddiqui, S., Gregerson, M., & Wilson, J. (2022). Like this meta-analysis: screen media and mental health. *Professional Psychology: Research and Practice*, 53, 205–214. <https://doi.org/10.1037/pro0000426>.
- Fisher, A. J., Medaglia, J. D., & Jeronimus, B. F. (2018). Lack of group-to-individual generalizability is a threat to human subjects research. *PNAS*, 115, E6106–E6115. <https://doi.org/10.1073/pnas.1711978115>.
- Gámez-Gaudix, M. (2014). Depressive symptoms and problematic internet use among adolescents: analysis of the longitudinal relationships from the cognitive-behavioral model. *Cyberpsychology, Behavior, and Social Networking*, 17, 714–719. <https://doi.org/10.1089/cyber.2014.0226>.
- George, M. J., Jensen, M. R., Russell, M. A., Gassman-Pines, A., Copeland, W. E., Hoyle, R. H., & Odgers, C. L. (2020). Young adolescents' digital technology use, perceived impairments, and well-being in a representative sample. *Journal of Pediatrics*, 219, 180–187. <https://doi.org/10.1016/j.jpeds.2019.12.002>.
- Green, J. G., Gruber, M. J., Sampson, N. A., Zaslavsky, A. M., & Kessler, R. C. (2010). Improving the K6 short scale to predict serious emotional disturbance in adolescents in the USA. *International Journal of Methods in Psychiatric Research*, 19, 23–35. <https://doi.org/10.1002/mpr.314>.
- Hagenauer, M. H., Perryman, J. J., Lee, T. M., & Carskadon, M. A. (2009). Adolescent changes in the homeostatic and circadian regulation of sleep. *Developmental Neuroscience*, 31, 276–284. <https://doi.org/10.1159/000216538>.
- Hollenstein, T., & Loughheed, J. P. (2013). Beyond storm and stress: typicality, timing, and temperament to account for adolescent change. *American Psychologist*, 68, 444–454. <https://doi.org/10.1037/a0033586>.
- Hu, L.-T., & Bentler, P. M. (1999). Cutoff criteria for fit indexes in covariance structure analysis: conventional criteria versus new alternatives. *Structural Equation Modeling*, 6, 1–55. <https://doi.org/10.1080/10705519909540118>.
- Ivie, E. J., Pettitt, A., Moses, L. J., & Allen, N. B. (2020). A meta-analysis of the association between adolescent social media use and depressive symptoms. *Journal of Affective Disorders*, 275, 165–174. <https://doi.org/10.1016/j.jad.2020.06.014>.
- Jensen, M., George, M. J., Russell, M. R., & Odgers, C. L. (2019). Young adolescents' digital technology use and mental health symptoms: little evidence of longitudinal or daily linkages. *Clinical Psychological Science*, 1416–1433. <https://doi.org/10.1177/2167702619859336>.
- Jose, P. E., Ryan, N., & Pryor, J. (2012). Does social connectedness promote a greater sense of well-being in adolescence over time? *Journal of Research on Adolescence*, 22, 235–251. <https://doi.org/10.1111/j.1532-7795.2012.00783.x>.
- Kardefelt-Winther, D. (2014). A conceptual and methodological critique of internet addiction research: Towards a model of compensatory internet use. *Computers in Human Behavior*, 31, 351–354. <https://doi.org/10.1016/j.chb.2013.10.059>.
- Kessler, R. C., Andrews, G., Colpe, L. J., Hiripi, E., Mroczek, D. K., Normand, S.-L. T., Walters, E. E., & Zaslavsky, A. M. (2002). Short screening scales to monitor population prevalences and trends in non-specific psychological distress. *Psychological Medicine*, 32, 959–976. <https://doi.org/10.1017/S0033291702006074>.
- Keyes, K. M., Gary, D., O'Malley, P. M., Hamilton, A., & Schulenberg, J. (2019). Recent increases in depressive symptoms among US adolescents: trends from 1991 to 2018. *Social Psychiatry and Psychiatric Epidemiology*, 54, 987–996. <https://doi.org/10.1007/s00127-019-01697-8>.
- Kouros, C. D., & Garber, J. (2014). Trajectories of individual depressive symptoms in adolescents: gender and family relationships as predictors. *Developmental Psychology*, 50, 2633–2643. <https://doi.org/10.1037/a0038190>.
- LaFontana, K. M., & Cillessen, A. H. N. (2010). Developmental changes in the priority of perceived status in childhood and adolescence. *Social Development*, 19, 130–147. <https://doi.org/10.1111/j.1467-9507.2008.00522.x>.
- Lanette, S., Chua, P. K., Hayes, G., & Mazmanian, M. (2018). How much is 'too much'? The role of a smartphone addiction narrative in individuals' experience of use. *Proceedings of the ACM on Human-Computer Interaction*, 2, 1–22. <https://doi.org/10.1145/3274370>.
- LeBourgeois, M. K., Hale, L., Chang, A.-M., Akacem, L., Montgomery-Downs, H. E., & Buxton, O. M. (2017). Digital media and sleep in childhood and adolescence. *Pediatrics*, 140, e2016758. <https://doi.org/10.1542/peds.2016-1758J>.
- Lee, E. W. J., Ho, S. S., & Lwin, M. O. (2017). Explicating problematic social network site use: a review of concepts, theoretical frameworks, and future directions for communication theorizing. *New Media & Society*, 19, 308–326. <https://doi.org/10.1177/1461444816671891>.
- Livingstone, S., & Helsper, E. J. (2010). Balancing opportunities and risks in teenagers' use of the internet: the role of online skills and internet self-efficacy. *New Media & Society*, 12, 309–329. <https://doi.org/10.1177/1461444809342697>.
- Marino, C. (2018). Quality of social-media use may matter more than frequency of use for adolescents' depression. *Clinical Psychological Science*, 6, 455. <https://doi.org/10.1177/2167702618771979>.
- Marino, C., Gini, G., Vieno, A., & Spada, M. M. (2018). A comprehensive meta-analysis on problematic Facebook use. *Computers in Human Behavior*, 83, 262–277. <https://doi.org/10.1016/j.chb.2018.02.009>.



- Marwick, A., & boyd, D. (2014). 'It's just drama': teen perspectives on conflict and aggression in a networked era. *Journal of Youth Studies*, 17, 1187–1204. <https://doi.org/10.1080/13676261.2014.901493>.
- McDaniel, B. T. (2015). "Technoference": everyday intrusions and interruptions of technology in couple and family relationships. In C. J. Bruess (Ed.), *Family communication in the age of digital social media*. Peter Lang Publishing.
- Miller-Johnson, S., Sullivan, T. N., & Simon, T. R. Multisite Violence Prevention Project. (2004). Evaluating the impact of interventions in the Multisite violence prevention study: samples, procedures, and measures. *American Journal of Preventive Medicine*, 26, 48–61. <https://doi.org/10.1016/j.amepre.2003.09.015>.
- Modecki, K. L., Duvenage, M., Uink, B., Barber, B. L., & Donovan, C. L. (2022). Adolescents' online coping: when less is more but none is worse. *Clinical Psychological Science*, 10, 467–481. <https://doi.org/10.1177/21677026211028983>.
- Morahan-Martin, J., & Schumacher, P. (2000). Incidence and correlates of pathological internet use among college students. *Computers in Human Behavior*, 16, 13–29. [https://doi.org/10.1016/S0747-5632\(99\)00049-7](https://doi.org/10.1016/S0747-5632(99)00049-7).
- Moreno, M. A., & Jolliff, A. F. (2022). Depression and anxiety in the context of digital media. In Nesi, J., Telzer, E. H., & Prinstein, M. J. (Eds.), *Handbook of adolescent digital media use and mental health* (pp. 217–241). Cambridge University Press.
- Muthén, L. K., & Muthén, B. O. (1998–2017). *Mplus User's Guide*. 8th Edition Los Angeles, CA: Muthén & Muthén.
- Nesi, J., Choukas-Bradley, S., & Prinstein, M. J. (2018). Transformation of adolescent peer relations in the social media context: part 1—a theoretical framework and application to dyadic peer relationships. *Clinical Child and Family Psychology Review*, 21, 267–294. <https://doi.org/10.1007/s10567-018-0261-x>.
- Nesi, J., & Prinstein, M. J. (2015). Using social media for social comparison and feedback-seeking: gender and popularity moderate associations with depressive symptoms. *Journal of Abnormal Child Psychology*, 43, 1427–1438. <https://doi.org/10.1007/s10802-015-0020-0>.
- Nesi, J., Rothenberg, W. A., Bettis, A. H., Massing-Schaffer, M., Fox, K. A., Telzer, E. H., Lindquist, K. A., & Prinstein, M. J. (2021). Emotional responses to social media experiences among adolescents: Longitudinal associations with depressive symptoms. *Journal of Clinical Child and Adolescent Psychology*. <https://doi.org/10.1080/15374416.2021.1955370>.
- Odgers, C. L., & Jensen, M. R. (2020). Annual research review: adolescent mental health in the digital age: facts, fears, and future directions. *The Journal of Child Psychology & Psychiatry*, 61, 336–348. <https://doi.org/10.1111/jcpp.13190>.
- Orben, A., Dienlin, T., & Przybylski, A. K. (2019). Social media's enduring effect on adolescent life satisfaction. *PNAS*, 116, 10226–10228. <https://doi.org/10.1073/pnas.1902058116>.
- Orben, A., Przybylski, A. K., Blakemore, S.-J., & Kievit, R. A. (2022). Windows of developmental sensitivity to social media. *Nature Communications*, 13, 1649 <https://doi.org/10.1038/s41467-022-29296-3>.
- Panova, T., & Carbonell, X. (2018). Is smartphone addiction really an addiction? *Journal of Behavioral Addictions*, 7, 252–259. <https://doi.org/10.1556/2006.7.2018.49>.
- Panova, T., & Lleras, A. (2016). Avoidance or boredom: negative mental health outcomes associated with use of information and communication technologies depend on users' motivations. *Computers in Human Behavior*, 58, 249–258. <https://doi.org/10.1016/j.chb.2015.12.062>.
- Parry, D. A., Davidson, B. I., Sewall, C. J. R., Fisher, J. T., Mieczkowski, H., & Quintana, D. S. (2021). A systematic review and meta-analysis of discrepancies between logged and self-reported digital media use. *Nature Human Behavior*, 5, 1535–1547. <https://doi.org/10.1038/s41562-021-01117-5>.
- Raudsepp, L. (2019). Brief report: problematic social media use and sleep disturbances are longitudinally associated with depressive symptoms in adolescents. *Journal of Adolescence*, 76, 197–201. <https://doi.org/10.1016/j.adolescence.2019.09.005>.
- Rideout, V., Peebles, A., Mann, S., & Robb, M. B. (2022). *Common sense census: Media use by tweens and teens, 2021*. San Francisco, CA: Common Sense.
- Rivenbark, J. G., Copeland, W. E., Davissou, E. K., Gassman-Pines, A., Hoyle, R. H., Piontak, J. R., Russell, M. A., Skinner, A. T., & Odgers, C. L. (2019). Perceived social status and mental health among young adolescents: evidence from census data to cellphones. *Developmental Psychology*, 55, 574–585. <https://doi.org/10.1037/dev0000551>.
- Takahashi, M., Adachi, M., Hirota, T., Nishimura, T., Shinkawa, H., Mori, H., & Nakamura, K. (2022). Longitudinal associations between addictive internet use and depression in early adolescents over a 2-year period: a study using a random intercept cross-lagged model. *Computers in Human Behavior*, 132, 107251 <https://doi.org/10.1016/j.chb.2022.107251>.
- Twenge, J. M., Martin, G. N., & Campbell, W. K. (2018). Decreases in psychological well-being among American adolescents after 2012 and links to screen time during the risk of smartphone technology. *Emotion*, 18, 765–780. <https://doi.org/10.1037/emo0000403>.
- Valkenburg, P., Beyens, I., Pouwels, J. L., van Driel, I. I., & Keijsers, L. (2021). Social media use and adolescents' self-esteem: heading for a person-specific media effects paradigm. *Journal of Communication*, 71, 56–78. <https://doi.org/10.1093/joc/jqaa039>.
- Vermeulen, M. C. M., van der Heijden, K. B., Kocavska, D., Treur, J. L., Huppertz, C., van Beijsterveldt, C. E. M., Boomsma, D. I., Swaab, H., Van Someren, E. J. W., & Bartels, M. (2021). Associations of sleep with psychological problems and well-being in adolescence: causality or common genetic predispositions? *Journal of Child Psychology and Psychiatry*, 62, 28–39. <https://doi.org/10.1111/jcpp.13238>.
- Vilhelmson, B., Eildér, E., & Thulin, E. (2018). What did we do when the Internet wasn't around? Variation in free-time activities among three young-adult cohorts from 1990/1991, 2000/2001, and 2010/2011. *New Media & Society*, 20, 2898–2916. <https://doi.org/10.1177/1461444817737296>.
- Weinstein, E., Kleiman, E. M., Franz, P. J., Joyce, V. W., Nash, C. C., Buonopane, R. J., & Nock, M. K. (2021). Positive and negative uses of social media among adolescents hospitalized for suicidal behavior. *Journal of Adolescence*, 87, 63–73. <https://doi.org/10.1016/j.adolescence.2020.12.003>.
- Wolfers, L. N., & Schneider, F. M. (2021). Using media for coping: a scoping review. *Communication Research*, 48, 1210–1234. <https://doi.org/10.1177/0093650220939778>.
- Yau, J. C., Reich, S. M., & Lee, T.-Y. (2021). Coping with stress through texting: an experimental study. *Journal of Adolescent Health*, 68, 565–571. <https://doi.org/10.1016/j.jadohealth.2020.07.004>.
- Young, K. (1999). Internet addiction: symptoms, evaluation, and treatment. In L. Van de Creek & T. Jackson (Eds.), *Innovations in Clinical Practice* (pp. 19–31). Prof Resource Press.
- Zimmer-Gembeck, M., & Skinner, E. A. (2011). The development of coping across childhood and adolescence: an integrative review and critique of research. *International Journal of Behavioral Development*, 35, 1–17. <https://doi.org/10.1177/0165025410384923>.

**Publisher's note** Springer Nature remains neutral with regard to jurisdictional claims in published maps and institutional affiliations.

Springer Nature or its licensor holds exclusive rights to this article under a publishing agreement with the author(s) or other rightsholder(s); author self-archiving of the accepted manuscript version of this article is solely governed by the terms of such publishing agreement and applicable law.

**Kaitlyn Burnell** is a Research Assistant Professor at the University of North Carolina at Chapel Hill. Her research interests include studying how adolescents and emerging adults use digital technologies in a way that both reflects and transforms traditional developmental tasks and challenges.

**Candice Odgers** is a Professor of Psychological Science at the University of California Irvine. Her research focuses on how social inequalities and early adversity influence children's future health and well-being, with an emphasis on how new technologies, including mobile phones and web-based tools, can be used to understand and improve the lives of young people.