

# Lawrence Berkeley National Laboratory

## Recent Work

### Title

ON-LINE VELOCITY MEASUREMENTS USING PHASE PROBES AT THE SUPERHILAC

### Permalink

<https://escholarship.org/uc/item/3vp898rm>

### Author

Leemann, B.

### Publication Date

1985-05-01

c.2



# Lawrence Berkeley Laboratory

UNIVERSITY OF CALIFORNIA

BERKELEY LABORATORY

JUL 18 1985

## Accelerator & Fusion Research Division

LIBRARY AND  
DOCUMENTS SECTION

Presented at the 1985 Particle Accelerator Conference,  
TRIUMF, Vancouver, B.C., Canada, May 13-16, 1985

ON-LINE VELOCITY MEASUREMENTS USING PHASE  
PROBES AT THE SUPERHILAC

B. Leemann, D. Brodzik, B. Feinberg,  
and D. Howard

May 1985

**TWO-WEEK LOAN COPY**  
*This is a Library Circulating Copy  
which may be borrowed for two weeks.*

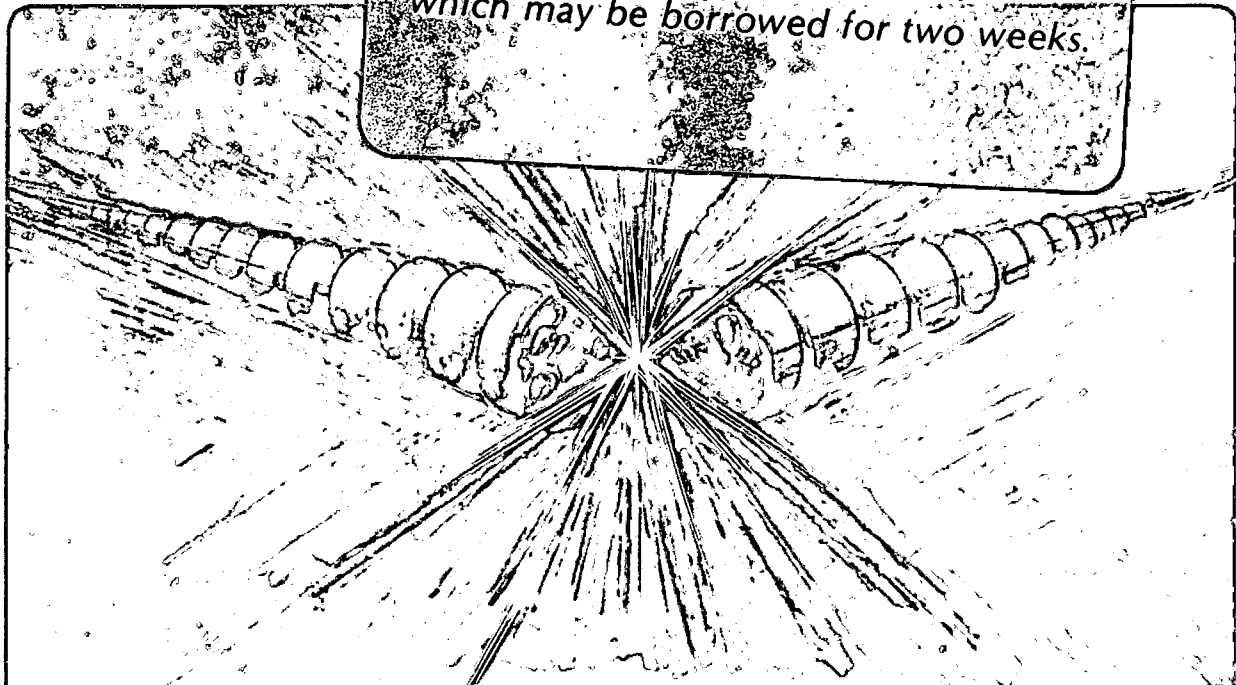

LBL-18961  
c.2

## **DISCLAIMER**

This document was prepared as an account of work sponsored by the United States Government. While this document is believed to contain correct information, neither the United States Government nor any agency thereof, nor the Regents of the University of California, nor any of their employees, makes any warranty, express or implied, or assumes any legal responsibility for the accuracy, completeness, or usefulness of any information, apparatus, product, or process disclosed, or represents that its use would not infringe privately owned rights. Reference herein to any specific commercial product, process, or service by its trade name, trademark, manufacturer, or otherwise, does not necessarily constitute or imply its endorsement, recommendation, or favoring by the United States Government or any agency thereof, or the Regents of the University of California. The views and opinions of authors expressed herein do not necessarily state or reflect those of the United States Government or any agency thereof or the Regents of the University of California.

B. Leemann, D. Brodzik, B. Feinberg, and D. Howard  
 University of California  
 Lawrence Berkeley Lab  
 1 Cyclotron Road  
 Berkeley, California 94720

### Summary

Phase probes have been placed in several external beam lines at the SuperHILAC to provide velocity measurements independent of the type of particle being accelerated. The system uses three probes in each line to obtain accurate velocity measurements at all beam energies. Automatic gain control and signal analysis are performed so that the energy/nucleon along with a representative probe signal are displayed on an oscilloscope every eight seconds. The system is accurate to within about  $\pm 0.25\%$ , and has provisions for on-line calibration tests. The phase probes thus provide a velocity measurement independent of the mass defect associated with the use of crystal detectors, which can become significant for heavy elements.

### Introduction

The SuperHILAC is capable of accelerating elements ranging in mass from hydrogen to uranium. As the accelerator is capable of continuously variable energies ranging from 1.2 MeV/nucleon to 8.5 MeV/nucleon, it is essential to have an unambiguous measurement of the beam energy to satisfy the experimental requirements. Normal operation can have as many as three different ions accelerated on a pulse to pulse basis with a maximum repetition rate of 36 Hz, so the energy measurements must be made during the appropriate machine pulse. In addition, since more than one charge state can be accelerated, often with slightly different energies, the measurement should be made in the appropriate experimental beamline after the charge states have been separated.

A system of capacitive electrodes called phase probes has been installed at the SuperHILAC to provide unambiguous velocity measurements for all ion beams irrespective of their mass. These phase probes are similar to those in use at GSI.<sup>1</sup> Figure 1 shows the five systems that have been set up in the SuperHILAC experimental area. Each system consists of three pick-up electrodes spaced along the beamline. The three electrodes are unequally spaced, with a short distance between two of the electrodes to provide a coarse estimate of the beam velocity, and a longer distance to provide the final measurement.

The system is fully computerized, with all controls accessible from a microcomputer in the main control room. During normal operation the beam energy/nucleon is displayed on an oscilloscope in the control room along with a representative probe signal, and updated every eight seconds. The operator has the option of choosing the set of probes to use and which of the 36 pulses/sec to observe, and can change the gain of individual probe amplifiers. In addition, the operator can choose one of two algorithms for analyzing the data, one that optimizes the speed of the computation, or one that is better at picking out a weak signal from noise.

\*This work was supported by the Director, Office of Energy Research, Office of High Energy and Nuclear Physics, Nuclear Science Division, U. S. Department of Energy under Contract No. DE-AC03-76SF00098.

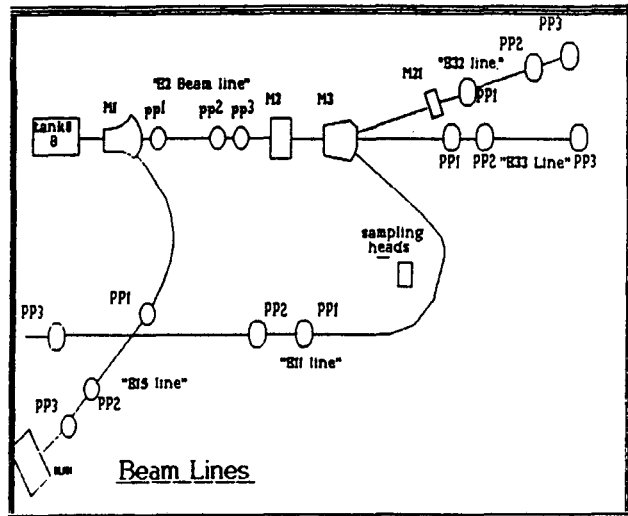

Fig. 1 Schematic of the phase probe locations in the beamlines leading to the experimental caves.

### Principles of Operation

Each phase probe system consists of a set of three capacitive electrodes that are coaxial with the beamline. The probe forms the center conductor of a coaxial 50 ohm line, as can be seen in Figure 2. The beam, bunched at 70 MHz, generates a signal by capacitively coupling to the probe as it passes along the probe axis. This signal is sampled at a sampling rate of about 2 MHz resulting in an alias frequency of 2 kHz. The aliased signal, which looks like the original phase probe signal but has a duration  $(70 \times 10^6)/(2 \times 10^3)$  times as long, is amplified, digitized, and transmitted to a microcomputer in the control room, where signal analysis takes place.

The system is set up (using the microcomputer in the control room) to process data from the desired set of probes on the appropriate machine pulses. Three probes make up one complete phase probe system. The three probes are set up with a short distance between (e.g.) probes 1 and 2, where probe 1 is the probe furthest upstream. The beam transit time for the short distance, typically 31 cm, determines the coarse velocity of the beam. All times are referenced to the RF system, so that probe signals separated by an integral number of RF periods will appear identical. The time difference between two successive probe signals, for example probes 1 and 2, can only be determined to the correct fraction of an RF period. No information is available on the integral number of RF periods separating the two signals.

The short distance ensures that the transit time will be 0.5 RF periods for a maximum beam energy of 10 MeV/nucleon. There will be no ambiguity if the minimum energy beam to be measured has a transit time for the short distance of no more than 1.5 RF periods, because all possible beam transit times will be separated by less than one full RF period. Given these requirements, beams with energies between 1 and 10 MeV/nucleon can be unambiguously identified.

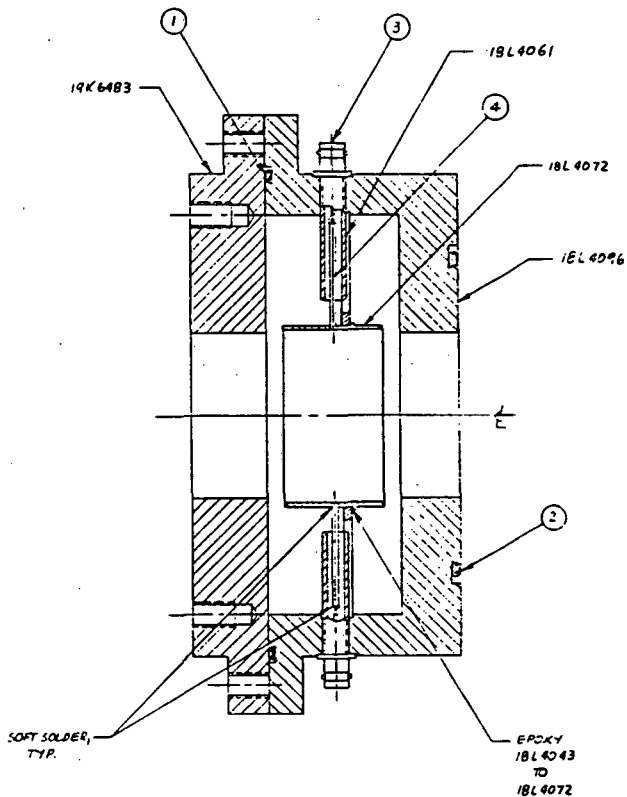

Fig. 2 Assembly drawing of one phase probe. Note the 50 ohm geometry and the existence of two feed-throughs, one for calibration input and one for signal output.

The energy calculation makes use of this coarse velocity to determine the correct number of integral RF periods to add to the fractional period obtained from the time difference between the signals of probes 1 and 3, the longest separation in a system. This procedure results in an accurate, unambiguous determination of the beam velocity. Since the long distance is about eight times the short distance, and the fractional period can be read to about one part in fifty, the system accuracy is  $\pm 0.25\%$ . Other sources of error, such as long term drift of delay lines, are ruled out by using the calibration procedure described below.

#### Hardware

The phase probe system is somewhat spread out through the superHILAC building. The brain of the system, the Intel microcomputer, is situated in the control room for easy access by the operations crew. Amplification and digitizing of the aliased signal are performed in a remote camac crate, while the sampling heads are located in the experimental area. After digitizing, the data is sent back to the microcomputer in the control room for data display and analysis. A block diagram of the system is shown in Figure 3.

An Intel Development System microcomputer controls the phase probe system. All control functions can be carried out by a computer program, transmitting the necessary control data on a serial data line to the camac crate located near the experimental areas. This camac crate contains three amplifiers (one for each probe signal) capable of

auto-ranging locally or of having the gain controlled by a signal sent from the computer. In addition, the Analog to Digital Converter (ADC) is in this rack.

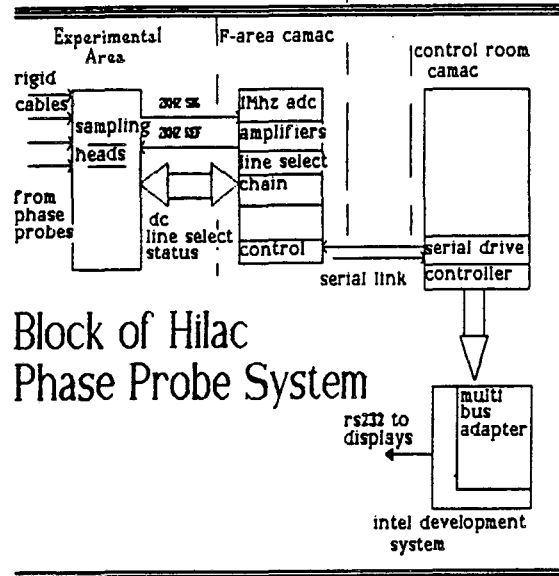

Fig. 3 Block diagram of the phase probe system, showing the microcomputer in the control room, the electronics in the "F" area, and the sampling heads in the experimental area.

The three sampling heads are located in the experimental area, within easy cabling distance of all five probe systems. High quality semi-rigid cable connects the sampling head to each probe since it is essential that the path length be stable and accurately known. During data acquisition three identical PIN diodes switch the sampling heads to the appropriate set of probes from the low level 70MHz reference signal used by the phase lock loop.

A calibration chassis is located in the experimental area to provide reference signals to check out the system. This chassis sends mock beam signals to the phase probes. Figure 2 shows that each probe has two connectors, one for signal output and one for input of the calibration signal. When the calibration signal is not being used the input is terminated in 50 ohms through a switch in the calibration chassis. Precisely cut delay lines are used to send the calibration signals to the probes, three lines for each of set of three probes. The lines are cut to simulate the arrival times of an 8.3MeV/nucleon beam at each probe, with different delays needed for each set of probes since the probe separations are not the same. The simulated signal from the calibration chassis that is sent to the phase probes is analyzed by the standard data acquisition system. If the result is 8.3MeV/nucleon the system is functioning correctly.

#### Data Analysis

An ideal phase probe signal is similar to one full period of a sine wave. The function of the data processing program is to pick out the zero crossing of the signal from each of the three probes. Two methods are now in use to determine the zero crossing. The simplest and fastest algorithm is to digitally

integrate each signal. A more complex pseudo-correlation technique is used to analyze noisy signals.

Using the first method, after integration the signal maximum appears at the original zero crossing, hence the zero crossing can easily be determined. The display is updated every eight seconds when this technique is used with data transfer taking up almost all of the time. While this algorithm is fast, it is difficult for it to pick out the signal when there is additional noise, especially when the noise is at a lower frequency than the signal. This problem comes about because the integral of a smaller magnitude lower frequency signal can equal the integral of larger magnitude high frequency signal, so the effect of low frequency noise is enhanced.

A pseudo-correlation techniques helps to pull out the signal from the noise. The actual phase probe signal is numerically multiplied by an ideal digitized signal at each point in time, and the sum is taken. The idealized signal is then stepped in time and the process is repeated until it is swept through the entire signal. Since the ideal signal consists of mostly zeros, the multiplication takes little computational time. When the signals are coincident in time, the sum will be a maximum, so the time step where the sum is maximized represents the zero crossing. Low frequency noise does not contribute inordinately to the sum since only that part of the noise which falls under the ideal signal contributes to the sum. The use of this algorithm increases the calculational time so that the display is updated every 18 seconds. It is typically used, therefore, when the integration technique gives poor results.

A third method of analysis is under development. This method would use a cross-correlation of two probe signals, instead of using a real signal and an idealized signal. Since the actual signals are used, one cannot make the a priori assumption that much of the signal consists of zeros, so this technique takes far more computational time. If it is determined that cross-correlation is superior, fast fourier transform methods can be applied to speed up computation. In addition there are plans to perform all computations in a local microcomputer to avoid shipping large quantities of data to the control room. Only the energy/nucleon and a single digitized phase probe signal for display (e.g. 50 points) would be sent over the serial link. This option would remove about seven seconds from the time between updates.

### Conclusion

On-line velocity measurements are being routinely performed at the SuperHILAC. The phase probe system provides a convenient means of determining the beam velocity to an accuracy of  $\pm 0.25\%$ . Operators can examine each of the different beams being accelerated at any one time from a console in the control room, regardless of the difference in beam intensity, energy, or mass. Use of the phase probe system provides an accurate velocity measurement independent of the mass defect associated with crystals.

### References

- [1] J. Klabunde et al, "Measurements of Energy, Energy Spread, and Bunch Width at the Unilac," Proceedings of the 1979 Linear Accelerator Conference, pp. 297-303.

3

This report was done with support from the Department of Energy. Any conclusions or opinions expressed in this report represent solely those of the author(s) and not necessarily those of The Regents of the University of California, the Lawrence Berkeley Laboratory or the Department of Energy.

1

Reference to a company or product name does not imply approval or recommendation of the product by the University of California or the U.S. Department of Energy to the exclusion of others that may be suitable.

TECHNICAL INFORMATION DEPARTMENT  
LAWRENCE BERKELEY LABORATORY  
UNIVERSITY OF CALIFORNIA  
BERKELEY, CALIFORNIA 94720