

Lawrence Berkeley National Laboratory

Recent Work

Title

USE OF ALUMINUM COILS INSTEAD OF COPPER COILS IN ACCELERATOR MAGNET SYSTEMS

Permalink

<https://escholarship.org/uc/item/3w171698>

Author

Green, Michael A.

Publication Date

1967-02-24

UCRL-17258

University of California

Ernest O. Lawrence
Radiation Laboratory

USE OF ALUMINUM COILS INSTEAD OF COPPER COILS
IN ACCELERATOR MAGNET SYSTEMS

TWO-WEEK LOAN COPY

*This is a Library Circulating Copy
which may be borrowed for two weeks.
For a personal retention copy, call
Tech. Info. Division, Ext. 5545*

DISCLAIMER

This document was prepared as an account of work sponsored by the United States Government. While this document is believed to contain correct information, neither the United States Government nor any agency thereof, nor the Regents of the University of California, nor any of their employees, makes any warranty, express or implied, or assumes any legal responsibility for the accuracy, completeness, or usefulness of any information, apparatus, product, or process disclosed, or represents that its use would not infringe privately owned rights. Reference herein to any specific commercial product, process, or service by its trade name, trademark, manufacturer, or otherwise, does not necessarily constitute or imply its endorsement, recommendation, or favoring by the United States Government or any agency thereof, or the Regents of the University of California. The views and opinions of authors expressed herein do not necessarily state or reflect those of the United States Government or any agency thereof or the Regents of the University of California.

TECHNICAL INFORMATION DIVISION

Lawrence Radiation Laboratory

Berkeley

Assigned to INFORMATION DIVISION

Route to	Noted
<i>Y. Berkner</i> ✓	JUN 27 1967

Please return this document to the Information Division. Do not send it to the next person on the list.

Please do not remove this page.

For Proceedings of the 1967 U. S. National
Particle Accelerator Conference, Washington,
D. C., March 1-3, 1967

UCRL-17258
Preprint

UNIVERSITY OF CALIFORNIA

Lawrence Radiation Laboratory
Berkeley, California

AEC Contract No. W-7405-eng-48

USE OF ALUMINUM COILS INSTEAD OF COPPER COILS
IN ACCELERATOR MAGNET SYSTEMS

Michael A. Green

February 24, 1967

USE OF ALUMINUM COILS INSTEAD OF COPPER COILS
IN ACCELERATOR MAGNET SYSTEMS*

Michael A. Green

Lawrence Radiation Laboratory
University of California
Berkeley, California

February 24, 1967

Abstract

Use of aluminum windings for the ac injector-synchrotron and dc storage ring magnet systems has been studied.^{1,2} The injector synchrotron is an 18-Hz fast-cycling 8-GeV accelerator that feeds protons to the 200-GeV main ring.

The physical properties of aluminum are discussed, as are the extrusion of the conductor and the winding of the coils. Also included is a discussion of cooling-system problems and their solution. Important design conditions for aluminum coils are given.

An economic analysis of aluminum- and copper-coiled magnet systems is presented. As an example, the injector-synchrotron magnet system is compared to a dc storage-ring magnet system with the same magnetic characteristics. The optimum coil current density is discussed, as are the effect of gap field, economic life, and core shape on cost and optimum current density.

Physical and economic advantages of aluminum coils for magnet systems are presented as are conditions under which the use of aluminum coils should be avoided.

Physical Parameters of Aluminum Coils

The physical characteristics of aluminum and copper coils depend on the physical properties of the metals. The metal properties directly affect conductor fabrication and coil winding.

Aluminum is probably one of the easiest metals to form. It can be extruded into continuous lengths in a wide variety of sizes and shapes of cross section.¹ Copper may either be drawn or extruded, however both products are limited in their cross-sectional geometries. Copper cannot be made in a continuous length; hence, hard-soldered joints are required in the coils.

*Work performed under the auspices of the U. S. Atomic Energy Commission.

Aluminum coils are easier to wind than copper coils, particularly in the strap configuration being proposed for the Omnitron synchrotron.³ Alcoa has observed that the keystone effect is reduced for aluminum conductors; this is currently being tested at the Stanford Linear Accelerator.[†] Aluminum is extruded fully-annealed. The conductor needs no heat treatment, and with proper extrusion technique, aluminum conductors should have more uniform properties than commonly found in drawn copper conductors. The aluminum coil will have a larger cross section which tends to increase the difficulty of winding. However, the low density of aluminum contributes to ease of handling.

Corrosion and the Aluminum-Coil System

The design of the aluminum-coil cooling system is restricted by the high electrochemical potential of aluminum which makes it subject to bimetallic corrosion. CERN reduced bimetallic corrosion by using aluminum piping of the same composition as the coils.⁴ I advocate this approach for entirely new magnet systems because it avoids the operation and maintenance problems that can result in mixed-metal systems.

Corrosion within the piping and coils can be further reduced by the formation of Böhmite (Al OOH) on cooling passage walls. Böhmite will form naturally in about 6 months through the reaction $2 \text{Al} + 4 \text{H}_2\text{O} \rightarrow 2 \text{Al OOH} + 3 \text{H}_2$. However, it is far better to artificially form the Böhmite coating using steam at 110°C for a couple of hours. The artificially-formed Böhmite coating is harder and will give better corrosion protection than the naturally-formed coating.

Cooling water must be deoxidized and deionized. Corrosion and electrolysis can be reduced by continuous water treatment in a closed system. Water for the aluminum cooling system must be separated from the cooling-tower water by a heat exchanger. CERN found that the cooling-tower

[†]E. Roskowski, SLAC, (private communication).

water was quite corrosive to aluminum. CERN also found that some types of stainless steel are compatible with aluminum from a corrosion standpoint. Stainless steel tubes are used in the CERN heat exchanger to carry the tower water.

Aluminum-Coil Design Considerations

In general the same basic design criteria that apply to copper coils also apply to aluminum coils. This section discusses only a few of the important design considerations. The coil fabrication technique should be carefully analyzed.

The voltage gradient along the hoses connecting the coils to the cooling-water pipes should be ≤ 100 V/in. Care should be taken to see that there is plenty of metal at points where deplating will occur. The blocks at the ends of the hoses should be removable.

Care should be taken during winding to reduce unnecessary cold working and keystoneing. The cooling passage should be Böhmed after winding but before potting the coil. The coil design should take into consideration the greater thermal expansion of aluminum.

CERN used gold-plated terminal lugs between the aluminum bus bar and the coils. The use of aluminum power cable should be considered; it is quite common today in the electric power industry.

Radiation affects aluminum coils differently than copper coils. The residual radiation from aluminum coils is due to Na^{24} formed by interaction with fast neutrons. The residual activity of aluminum coils several days after shutdown should be lower than for copper coils due to the short half-life of Na^{24} . CERN has not reported any particular problem in this respect with their coils. Radiation damage to coil insulation should not be affected by the metal selected for the conductor.

Cost Optimization of Aluminum and Copper Magnet Systems

My primary argument for the use of aluminum coils is economy. The cost advantage of aluminum comes primarily from its low density. The incremental cost of aluminum coils and that of copper is nearly the same per unit weight. Using the simplified linearized cost equation given below, I will show that both the magnet capital cost (coil and core) and the power consumption are less for aluminum-coil magnets. The magnet system cost is

$$C_{m.s.} = A \rho S_c \ell + B (Ni)^2 \frac{Res \ell}{S_c},$$

where A is the coil and core incremental cost coefficient in \$/g of coil metal, ρ is the coil metal density in g/cm^3 , S_c is the coil metal cross-section area in cm^2 , ℓ is the total mean length of the magnet coil, B is the operating cost of the power supply and cooling system for 67 500 h, in \$/W, Ni is the total current ampere turns in the coil, and Res is the resistivity of the coil metal. The magnet-system cost equation does not consider the nonlinearities of the iron design, the magnet end effect, and the magnetic efficiency effects of the magnet's stored energy.

The current density of the coil is defined as

$$\eta = \frac{Ni}{S_c}.$$

Rewriting the cost equation in terms of η , we have

$$C_{m.s.} = \frac{A \rho Ni \ell}{\eta} + B \eta Res Ni \ell,$$

for the linearized system with A, ρ , Ni, ℓ , B, and Res constant with respect to cost. Differentiating this equation with respect to η and setting it equal to zero, we have after some algebraic manipulation,

$$\eta = \left[\frac{A \rho}{B Res} \right]^{1/2}.$$

The power consumed by the magnet is

$$P_M = \eta Res Ni \ell,$$

and the magnet capital cost is

$$C_{cap.} = \frac{A \rho Ni \ell}{\eta}.$$

Since in the linearized system Ni and ℓ are constants, their product is another constant, which I will call α . Table I demonstrates that the magnet capital cost and power consumption are less for optimum aluminum-coiled magnets.

Table I. Current density and power consumption for a typical linearized dc magnet system.

	Aluminum	Copper
A (\$/g)	0.0089	0.0082
B (\$/W)	0.83	0.79
ρ (g/cm^3)	2.7	8.9
Res (Ω -cm)	2.88×10^{-6}	1.72×10^{-6}
η (A-cm ⁻²)	98	224
P_M (W)	$2.85 \times 10^{-4} \alpha$	$3.85 \times 10^{-4} \alpha$
$C_{cap.}$ (\$)	$2.43 \times 10^{-4} \alpha$	$3.26 \times 10^{-4} \alpha$

The optimum current densities shown in Table I compare favorably with those for the dc case in Table IV. Note that the rms current and the maximum current are different for the ac coils.

The cost optimization cases demonstrated here are for the 200-BeV accelerator injector synchrotron magnets and the magnets of a single-energy dc storage ring with the same parameters as the injector synchrotron magnets.⁶ Both types of magnets have a 7.12-kG peak field at the beam centerline, and a gradient of 4.419 m⁻¹. The aperture, pole width, leg widths, coil spacing and size and arrangement of the magnet system are the same for both cases (see Figs. 1 and 2).⁵

The differences between the two magnet systems are: (1) ac magnets require a resonant power supply; dc magnets do not. (2) ac magnets use 0.025-in. thick laminations of M-22 electrical steel to reduce core loss; dc magnets use 0.062-in. thick laminations of a low-silicon electrical steel such as M-45. (3) The coil window packing factor is 0.38 for the ac case because extra insulation is required and spacing must be provided to reduce capacitive coupling to ground; the dc coil window packing factor is 0.65.

The cost of the magnet system is estimated by using MAGHYP, a computer program that calculates and optimizes the total cost of magnet systems. Included in the optimization are cost of the core, coil, cooling-system, power-supply, and operation for 67 500. Not included is the effect of the magnet size on the foundation and enclosure.

The cost of the coil and core are fed into the computer in terms of the following equation:

$$\text{Core (or coil) cost} = A + (d\$/dw) w$$

where A is the constant shown in Figs. 3 and 4 and d\$/dw is the incremental cost in \$/lb and w is weight in pounds of the core or coil. The core and coil cost coefficients are given in Table II. The cost of the power supply is calculated by using the power-supply subroutine. The cost of an ac power supply is a function of stored energy, repetition rate, core loss, and coil I²R loss. The dc power-supply cost is a function of I²R loss only.^{1, 2} The cooling-system cost in \$/kW is a function of power consumed in the coil. The cooling-system cost coefficient for aluminum coils is higher than for copper. This reflects the extra amount for water treatment and the stainless steel heat exchangers required for aluminum.¹ The assumed operating cost of the power supply and cooling system is \$0.0079/kWh.

Table II. Cost coefficients used to calculate costs of the core, coil, water-cooling system, power supply, and operation.

		18-Hz injector-synchrotron magnet	dc storage-ring magnet
Copper coils	A (\$)	203 000	203 000
	d\$/dw (\$/lb)	3.00	3.00
Aluminum coils	A (\$)	203 000	203 000
	d\$/dw (\$/lb)	2.60	2.60
Core	A (\$)	785 000	471 000
	d\$/dw (\$/lb)	0.50	0.40
Aluminum water-system cost (\$/kW)		200	200
Copper water-system cost (\$/kW)		160	160
Power supply cost (\$/kW)		Not a simple function of I ² R loss	100

Comparison of Aluminum and Copper Magnet-System Costs and Current Densities

The injector-synchrotron magnet-system costs are compared with the dc storage-ring costs in Table III, which breaks the magnet-system cost into its various components.

Table III illustrates the difference between the ac and dc system. The resonant power supply and increased operating cost contribute greatly to the increased cost of the ac system. However, both the ac and dc system follow the trend indicated by the linearized cost analysis shown in Table I.

The rms current densities at minimum cost are given in Table IV. For the dc case the rms current equals the maximum exciting current. The bias sine-wave ac rms current is (3/8)^{1/2} times the maximum exciting current. The rms current density for the dc case compares favorably with the linearized calculations shown in Table I. The increased rms current density for the ac system results from the reduced coil packing factor, the end effects, and the higher cost of the magnet steel. The power supply has only a small effect on the optimum current density.

Table III. Breakdown of cost for the optimized injector synchrotron magnets and optimized dc storage-ring magnets, in millions of dollars.

Part	Copper coils		Aluminum coils	
	ac injector synchrotron	dc storage ring	ac injector synchrotron	dc storage ring
Coils	0.585	0.993	0.414	0.689
Cores	1.606	1.149	1.746	1.290
Magnets	2.191	2.142	2.160	1.979
Power supply	1.873	0.130	1.837	0.094
Water-cooling system	0.189	0.204	0.181	0.185
Air-conditioning system	0.048	---	0.057	---
Magnet-system capital cost	4.302	2.476	4.234	2.258
Magnet-system operating cost for 67 500 h	1.442	0.683	1.307	0.496
Magnet system total cost	5.743	3.159	5.542	2.754

Table IV. A comparison of optimum rms current density in A/cm² for copper and aluminum coils.

	Copper coils	Aluminum coils
Injector synchrotron ac system	282	137
dc storage ring system	224	99

The optimum current density for the dc-storage-ring case applies to a wide variety of dc magnets. Increasing the gap field increases the optimum current density only slightly if high magnetic efficiency is maintained. Costs have been analyzed for a variety of core shapes, including H-gradient magnets, H-nongradient bending magnets, quadrupoles, and sextupoles. The core shape did not effect optimum current density by more than a few percent. The useful economic life has the largest effect on optimum current density of all parameters tested (see Table V).

Table V. Effect of useful economic life on the optimum conductor current density for dc systems.

Economic life		Current density (A/cm ²)	
h	yr	Copper coils	Aluminum coils
0	0	407	172
33 750	5	283	120
67 500	10	224	99
135 000	20	169	75

A similar set of current densities would apply to the ac injector-synchrotron magnets.

Conclusions

In general aluminum magnet systems appear to cost less than copper magnet systems. Aluminum coils should be used where their physical and economic advantages can be maximized such as (1) when the magnet system can be fully optimized and is not space limited; (2) when the magnet system is large or where the magnet system can be tied into an existing aluminum magnet-system cooling system; (3) in magnets where the physical properties of aluminum can be fully utilized (e.g., in the Omnitron strap-wound storage ring coils;³ or (4) in laboratories where electric power is expensive and when the operating cost is high enough to be important. Aluminum magnets should be avoided when the following conditions prevail: (1) When the magnet system is small and requires a special cooling system. Mixed-metal cooling systems should be avoided. Some laboratories do not consider this to be very important, but I feel that one should avoid mixed-metal systems unless the economic advantage for aluminum coils is clear. (2) In high-current-density septum magnets. The power consumption goes up by a factor of 1.6. Aluminum coils only aggravate the heat-transfer problems.

I feel that the future of aluminum coils is very bright for large, conventional, fully-optimized magnet systems.

References

1. Michael A. Green, "A Comparison Between Copper and Aluminum for the Injector-Synchrotron Gradient Magnet Coils," LRL Engineering Note UCID-2883, January 1967.
2. Michael A. Green, "A Comparison Between Copper and Aluminum for dc Magnet Coils," LRL Engineering Note UCID-2888, March 1967.
3. The Omnitron, A Multipurpose Accelerator, Lawrence Radiation Laboratory Report UCRL-16828, July 1966.
4. The CERN Proton Synchrotron Magnet, edited by K. H. Reich, CERN 63-13 (1963).
5. The 200-BeV Accelerator Design Study, Lawrence Radiation Laboratory Report UCRL-16000, June 1965.
6. H. Paul Hernandez, "Selection of a Lamination Shape for a Fast-Cycling Alternating-Gradient Magnet," (Paper D-3 of these Proceedings).

FIGURE LEGENDS

- Fig. 1. Injector synchrotron ring arrangement.
- Fig. 2. A typical injector synchrotron superperiod showing the magnet elements, ac and dc.
- Fig. 3. Magnet core cost vs core weight, showing the derivation of the cost estimating equation for the core.
- Fig. 4. Copper and aluminum coil cost vs coil weight showing the derivation of the cost estimating equation for the coils.
- Fig. 5. Magnet system cost vs conductor current density.
- Fig. 6. The optimum injector synchrotron and storage ring magnet cross sections.

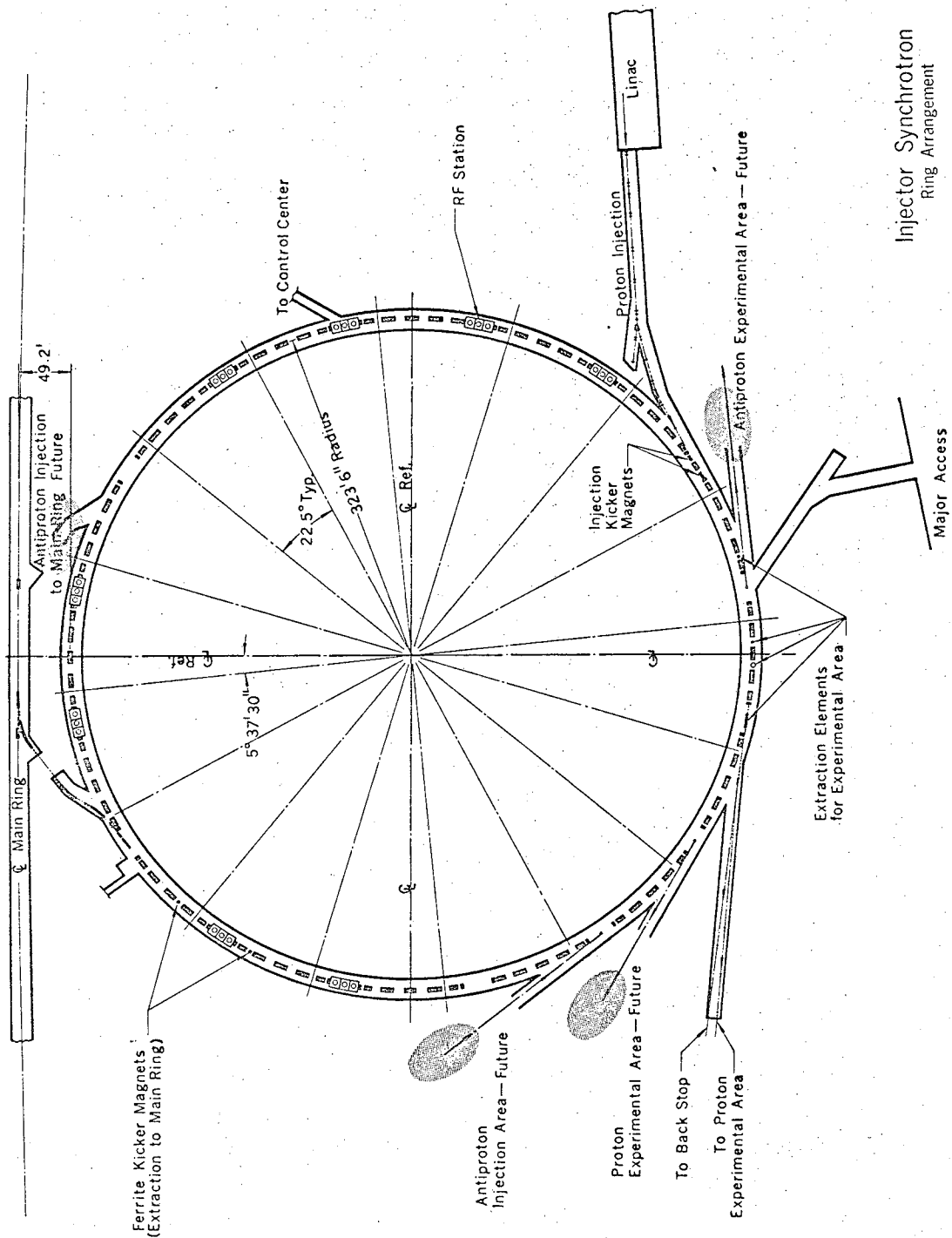

Injector Synchrotron Ring Arrangement

MUB-6837

Fig. 1

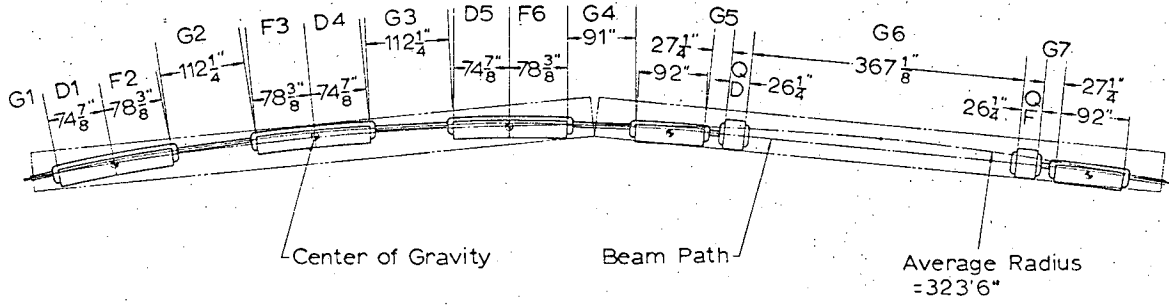

Injector Synchrotron Superperiod

Fig. 2

MUB-7081

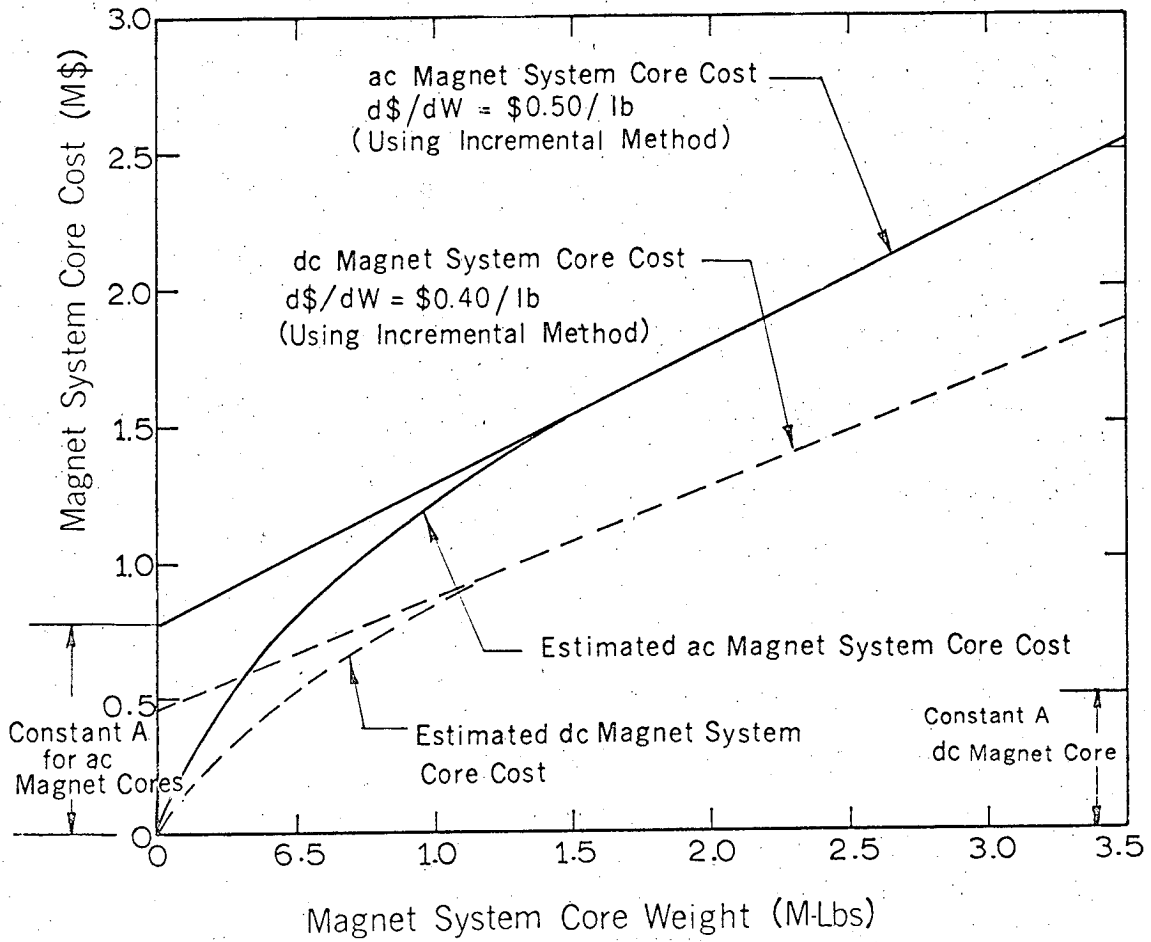

Fig. 3

XBL672-2008

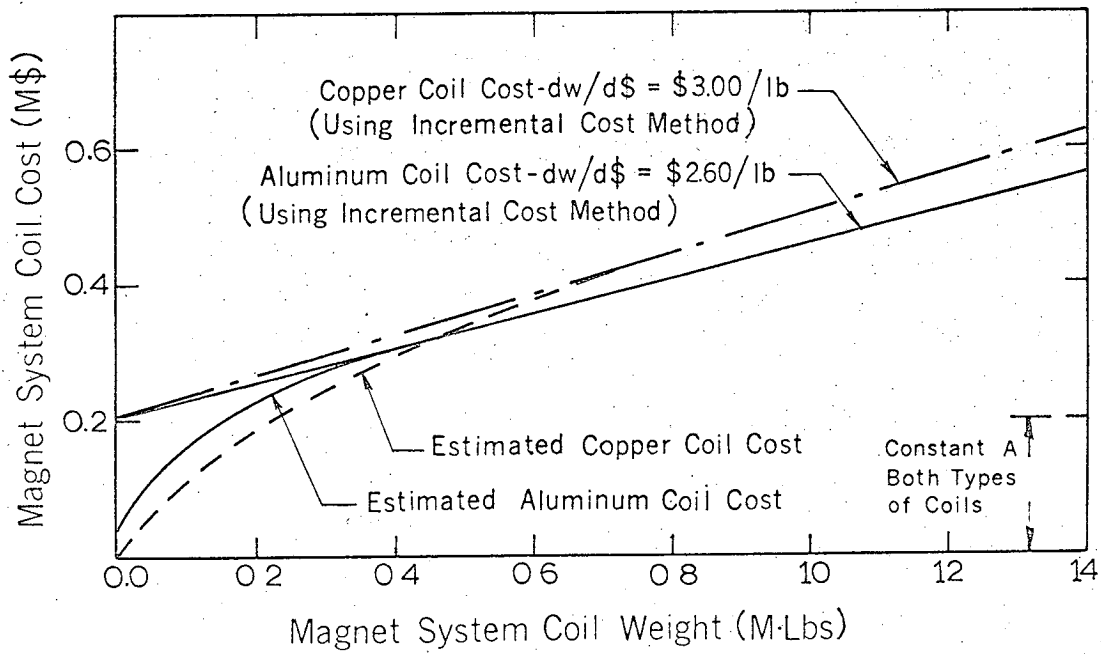

Fig. 4

XBL672-2007

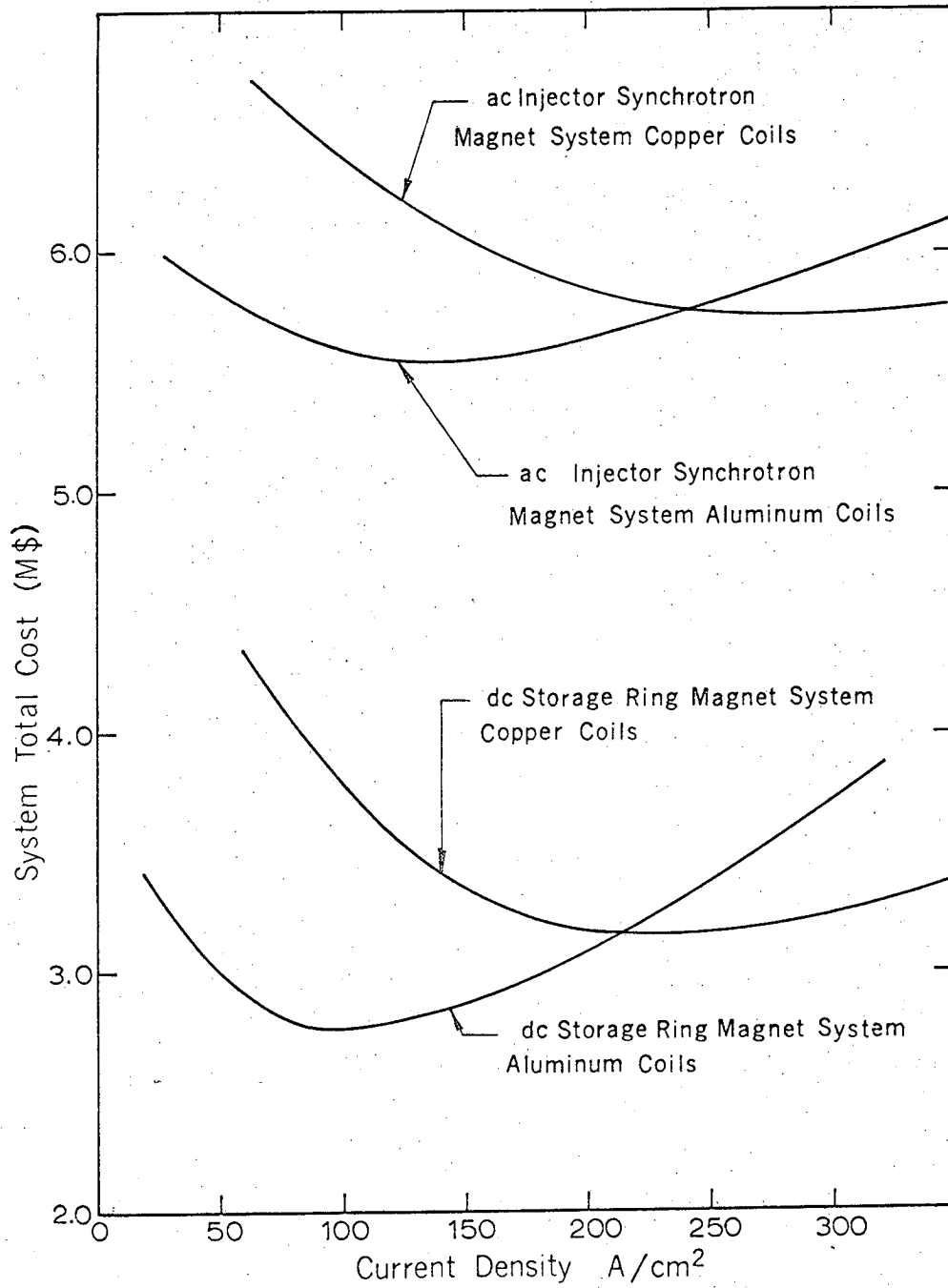
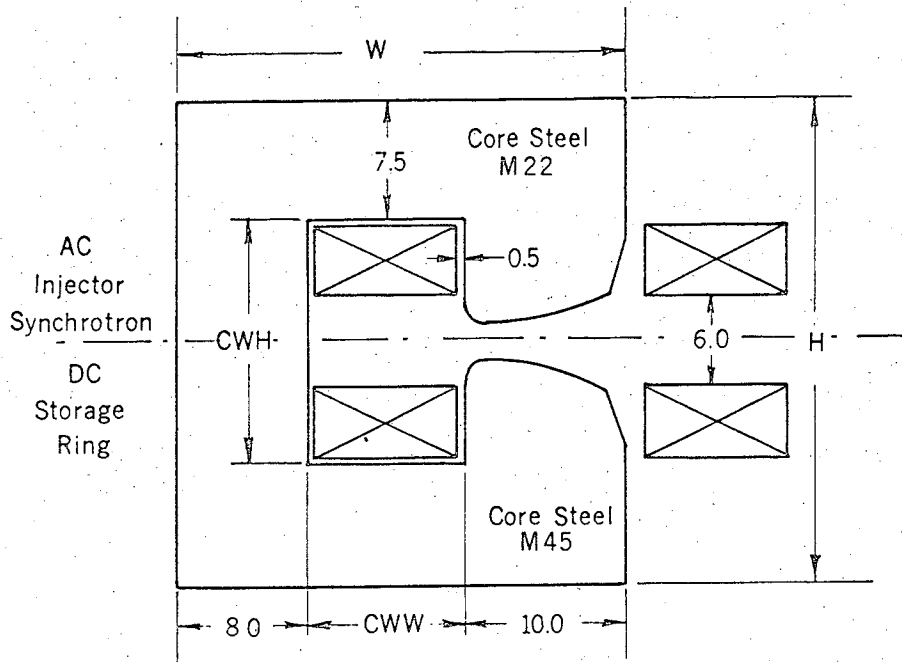

Fig. 5

XBL672-2009



Magnet System	Metal for Magnet Coils	W	H	CWW	CWH
Injector Synchrotron ac Magnets	Copper	24.84	27.59	6.84	12.59
	Aluminum	27.82	30.45	9.82	15.45
dc Storage Ring Magnets	Copper	25.40	28.13	7.40	13.13
	Aluminum	29.16	31.75	11.16	16.75

Fig. 6

XBL672-2010

This report was prepared as an account of Government sponsored work. Neither the United States, nor the Commission, nor any person acting on behalf of the Commission:

- A. Makes any warranty or representation, expressed or implied, with respect to the accuracy, completeness, or usefulness of the information contained in this report, or that the use of any information, apparatus, method, or process disclosed in this report may not infringe privately owned rights; or
- B. Assumes any liabilities with respect to the use of, or for damages resulting from the use of any information, apparatus, method, or process disclosed in this report.

As used in the above, "person acting on behalf of the Commission" includes any employee or contractor of the Commission, or employee of such contractor, to the extent that such employee or contractor of the Commission, or employee of such contractor prepares, disseminates, or provides access to, any information pursuant to his employment or contract with the Commission, or his employment with such contractor.

