



Lawrence Berkeley Laboratory

UNIVERSITY OF CALIFORNIA

Materials & Molecular Research Division

RECEIVED
BERKELEY LABORATORY
AUG 10 1983
LIBRARY AND
DOCUMENTS SECTION

Submitted to the Journal of the American Chemical
Society

QUASI-RELATIVISTIC SCF-X α SCATTERED-WAVE STUDY
OF URANOCENE, THOROCENE AND CEROCENE

N. Rösch and A. Streitwieser, Jr.

June 1983

TWO-WEEK LOAN COPY

*This is a Library Circulating Copy
which may be borrowed for two weeks.
For a personal retention copy, call
Tech. Info. Division, Ext. 6782.*

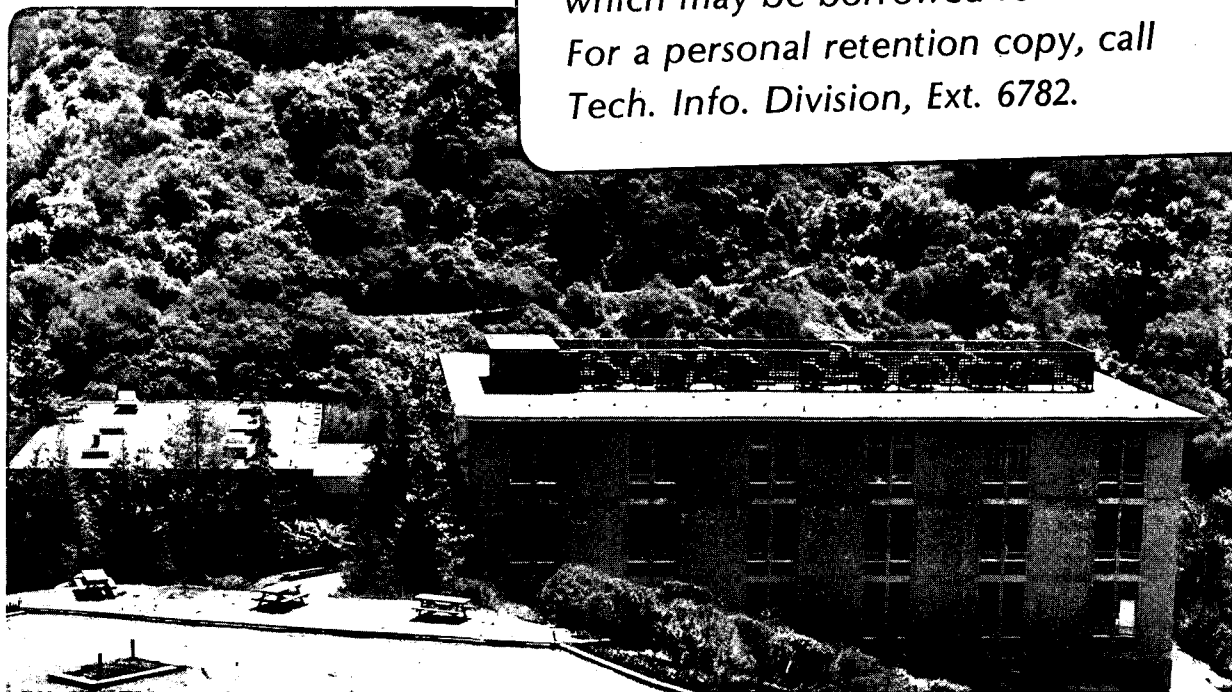

DISCLAIMER

This document was prepared as an account of work sponsored by the United States Government. While this document is believed to contain correct information, neither the United States Government nor any agency thereof, nor the Regents of the University of California, nor any of their employees, makes any warranty, express or implied, or assumes any legal responsibility for the accuracy, completeness, or usefulness of any information, apparatus, product, or process disclosed, or represents that its use would not infringe privately owned rights. Reference herein to any specific commercial product, process, or service by its trade name, trademark, manufacturer, or otherwise, does not necessarily constitute or imply its endorsement, recommendation, or favoring by the United States Government or any agency thereof, or the Regents of the University of California. The views and opinions of authors expressed herein do not necessarily state or reflect those of the United States Government or any agency thereof or the Regents of the University of California.

QUASI-RELATIVISTIC SCF- X_α SCATTERED-WAVE
STUDY OF URANOCENE, THOROCENE AND CEROCENE

Notker Rösch and Andrew Streitwieser, Jr.

June, 1983

Lehrstuhl für Theoretische Chemie
Technical University Munich, D-8046
Garching, West Germany

and

Materials and Molecular Research Division
Lawrence Berkeley Laboratory
Department of Chemistry
University of California
Berkeley, California 94720

This work was supported in part by NATO grant #1237,
and in part by the Director, Office of Energy Research,
Office of Basic Energy Sciences, Chemical Sciences
Division of the U.S. Department of Energy, under
Contract No. DE-AC03-76SF00098.

Quasi-Relativistic SCF- $X\alpha$ Scattered-Wave Study
of Uranocene, Thorocene and Cerocene

Notker Rösch* and Andrew Streitwieser, Jr.¹

Lehrstuhl für Theoretische Chemie, Technical University Munich,
D-8046 Garching, West Germany

Abstract

Quasi-relativistic SCF- $X\alpha$ scattered wave calculations are presented for di- π -[8]annulene-uranium (IV) (uranocene), -thorium(IV) (thorocene) and -cerium(IV) (cerocene). Improved agreement over previous non-relativistic results is found both for optical absorption spectra and photoelectron spectra. An explanation is presented for the apparent relative success of the previous non-relativistic calculations. The quasi-relativistic calculations confirm that $f_{\pm 2}$ orbitals of the central metal atom contribute to the covalent ring-metal bonding, but emphasize even more than the non-relativistic treatment the important role of the 6d orbitals in such bonding.

Introduction

Uranocene, di- π -[8]annuleneuranium(IV), was prepared² as an expected f-orbital analog to the d-transition metal metallocenes. An important amount of ring-metal covalency results in a compound such as ferrocene from the interaction of the highest occupied e_{1g} MOs of the two cyclopentadienyl anions with the vacant $3d_{\pm 1}$ orbitals of Fe^{+2} . A corresponding interaction with the highest occupied e_{2u} MOs of the two [8]annulene dianions is expected from the vacant $5f_{\pm 2}$ orbitals of an actinide anion such as U^{+4} . Extended chemical and spectroscopic investigations³ indicate a significant amount of covalent actinide π -ligand interaction.

In a previous SCF-X α Scattered-Wave (SW) MO study⁴ we have found that $5f_{\pm 2}$ orbitals of the central atom do indeed contribute to the ring-metal bonding in uranocene and thorocene, but that 6d orbitals are also at least equally important. Agreement with photoelectron spectra was remarkably good, despite the fact that relativistic effects had not been taken into account. The inclusion of such effects even at a molecular orbital level is known to lead to considerable improvements in the description of the electronic structure of heavy metal complexes.⁵ We report here quasi-relativistic X α -SW MO calculations of uranocene, thorocene and the analogue lanthanide system $Ce(C_8H_8)_2$ (cerocene). The lanthanide compound has been reported as a crystalline material isomorphous with uranocene and thorocene.⁶ By comparing our calculations for the actinide and lanthanide systems we expected to gain further insight into the relative importance of covalent bonding in these f-orbital sandwich compounds.

Computational Details

In this study we use a non-perturbative self-consistent approximation⁷ to the SW treatment of the relativistic Dirac-Slater $X\alpha$ model⁸ that has proven well suited for MO calculations of large molecules containing heavy elements.⁹ Relativistic effects are largest for core levels which are localized in the vicinity of a nucleus and therefore influence the formation of chemical bonds primarily via shielding effects. The SW model¹⁰ with its underlying muffin-tin geometry confines core levels to one atomic sphere thereby treating them essentially as in atomic problems.¹¹ The most important relativistic effects on valence levels may be described as mass-velocity correction and Darwin shift, the spin-orbit interaction being usually much smaller, at least in molecules. It is a rather good approximation⁷ to neglect these effects altogether in the intersphere region of the muffin-tin geometry. We take them into account only when calculating the logarithmic derivative of the various radial wavefunctions necessary for the matching at the sphere boundaries. The resulting SW problem is then essentially identical to the nonrelativistic treatment.^{7,10} The use of double groups, mandatory in the fully relativistic SW problem,¹² may thus be avoided. The approach of the present work, though formally somewhat different, is similar to the quasi-relativistic treatment of Cowan and Griffin¹³ as incorporated into the $X\alpha$ method by Boring and Wood.¹⁴

All calculations were performed with the same idealized geometry employed previously.⁴ Planar [8]annulene rings with "standard" C-C bond lengths of 1.40 Å and C-H bond lengths of 1.09 Å were assumed in D_{8h} symmetry with a ring-ring distance of 3.89 Å. The resulting metal-carbon bond length of 2.67 Å lies inbetween that found in uranocene (2.647 Å) and thorocene (2.701 Å). A somewhat larger bond length is found for the Ce(III) compound $Ce(COT)_2^-$

(2.742 Å)^{3b} but the neutral Ce(IV) is expected to have a shorter metal-carbon distance. We note, for example, that the ionic radius of Ce⁺⁴ is close to that of U⁺⁴.¹⁵ The differences from the various experimental structures are small in any case. By choosing a uniform muffin-tin geometry in all calculations identical to that used previously,⁴ we hoped to compare the electronic structure of the various compounds, especially the charges within the muffin-tin spheres, without introducing additional uncertainties. Starting from geometry-induced touching spheres the carbon radii were enlarged by 26 percent to ensure a better description of the ring π -system. This procedure results in the following radii (in Å): $r_{\text{metal}} = 1.788$, $r_{\text{C}} = 0.882$, $r_{\text{H}} = 0.491$, and $r_{\text{out}} = 3.999$. The maximum ℓ values in the partial wave expansions included in the calculation were $\ell = 3$ in the metal sphere, $\ell = 1$ for C, $\ell = 0$ for H and $\ell = 5$ in the extramolecular region. The scattered wave expansion is essentially converged with the inclusion of these partial wave components as was confirmed by a study employing more partial waves ($\ell = 5, 2, 1$ and 7 , respectively).

The atomic exchange scaling parameters α were taken from the values calculated by Schwarz:¹⁶ $\alpha_{\text{C}} = 0.75331$, $\alpha_{\text{H}} = 0.77725$, $\alpha_{\text{Ce}} = 0.69845$, $\alpha_{\text{M}} = 0.692$ (for M = U, Th). The scaling parameters α for the interatomic and extramolecular region was set to 0.76230, a weighted average over the atomic values. The core charge densities for C([He]), Ce([Kr]), Th and U([Xe]4f)¹⁴ were kept fixed as obtained from atomic Dirac-Slater calculations.¹¹ All other electrons were considered fully in the iterations towards self-consistency but spin-orbit interaction and spin-polarization (in the case of uranocene) were neglected. Slater's "transition-state" procedure⁸ was used to compute the ionization potentials.

To evaluate the ring-metal interaction a cluster of two neutral [8]annulenes (a "dimer") was also calculated by employing the identical muffin-tin geometry with an "empty" sphere present in place of the metal atom.¹⁰ The configuration used for the SCF- $X\alpha$ calculation of this cluster was $e_{2g}^4 e_{2u}^0$. The same energy levels were obtained as in a previous calculation⁴ of a dimer built from two dianions, with the exception of a roughly uniform stabilization by 0.11 Ry.

Results and Discussion

We first want to address the question of how relativistic effects influence the description of the electronic structure of the systems under study. Let us discuss uranocene as an example in more detail. Rather similar effects were found for thorocene, whereas cerocene, not unexpectedly, shows less difference between the non-relativistic and the quasi-relativistic treatment.

We expect the relativistic mass-velocity correction to lower the metal s and p levels; this is exactly what happens. The upper part of the MO energy spectrum for uranocene is shown in Fig. 1 and compared to $X\alpha$ atomic levels and to the orbital energies of the "dimer". The π -type ligand MOs undergo a slight downward shift (by approximately 0.02 Ry) whereas the σ -type ligand MOs (e.g., e_{3g} , e_{3u} , e_{2u} , e_{2g} , b_{1u} and b_{2g} in Fig. 1) stay virtually unchanged. The largest energy changes of this kind are found for the MOs which may be identified as U 6s and 6p. The corresponding a_{1g} shifts from -2.269 Ry down to -3.502 Ry. The 6p electrons, in the non-relativistic treatment rather localized in an a_{2u} level at -1.258 Ry and an e_{1u} level at -1.269, are now shared between two pairs of levels of the appropriate symmetry: a_{2u} at -1.429 and -1.703 Ry, e_{1u} at -1.435 and -1.619 Ry. These 6p levels would undergo a sizeable spin-orbit splitting. However, we expect the neglect of this interaction to have no appreciable effect on the charge distribution of these MOs and, consequently, on the valence electron levels which are the major concern in this study.

The U 5s and 5p electrons undergo the well-known relativistic core contraction,⁵ which in our calculation is fully taken into account by the use of relativistic core charge densities. The most conspicuous consequence of the resulting increased shielding by s and p electrons is the 5f orbital expansion which is clearly displayed for the atomic $X\alpha$ levels in Fig. 1. It is this change in the wavefunction of the 5f electrons which renders them suitable for interaction with the ligand π -orbitals. The question then arises why the non-relativistic treatment gave essentially the same description⁴ of the ring-metal bonding, as deduced below from the ordering and the character of π -type orbitals.

The answer may be found in a peculiarity of the $X\alpha$ formalism. The atomic levels displayed in Fig. 1 correspond to the configuration $5f^3 6d^1 7s^2$; however, this is not the $X\alpha$ ground state for uranium because in order to fulfill Fermi statistics, the levels have to be filled strictly from below.⁸ To obtain the $X\alpha$ ground state, one has to redistribute electrons (or fractions thereof) such that partially filled orbitals have the same energy. The non-relativistic $X\alpha$ ground state of uranium has the configuration $5f^{4.66} 6d^0 7s^{1.34}$ with the highest occupied level at -0.151 Ry for 5f and 7s. The relativistic $X\alpha$ ground state, on the other hand, is much closer to reality with its configuration $5f^{3.41} 6d^{0.59} 7s^2$. The highest occupied level is found at -0.117 Ry and this upward shift is reflected almost quantitatively in the 5f orbital manifold of uranocene (see Fig. 1). The ligand field splitting remains virtually unchanged at 0.093 Ry (1.27 eV). This value is much larger than that in semi-empirical treatments¹⁷ of uranocene (0.45 eV). The ordering of the metal f orbitals, $e_{3u} < e_{1u} \leq a_{2u} < e_{2u}$ is confirmed.

If our argument to use the proper $X\alpha$ ground state in the discussion of resulting MOs is correct, we would expect from perturbation theory that the interaction of the uranium 5f orbitals with the $e_{2u}(\pi)$ "dimer" orbital at -0.220 Ry should be weaker in the relativistic treatment. This is indeed found: the

charge fraction of this MO in the uranium sphere decreases from 0.46 to 0.33. Concomitantly, one finds an increase of the metal character in the antibonding $e_{2u}(f)$ partner in quantitative agreement (from 0.54 to 0.67).

Recently, Pyykkö and Lohr¹⁸ have carried out a relativistically parameterized extended Hückel molecular orbital (REX) calculation for uranocene. Their results agree with ours in that they also find the ordering $e_{2g} < e_{2u}$ for the two highest ligand derived orbitals with negligible spin-orbit splittings (~ 0.002 Ry). They find less metal contribution in these orbitals (for e_{2u} : 14.5%; 8.6%; for e_{2g} : 10.8%, 10.5%) than we do (e_{2u} : 33%, e_{2g} : 20%), but also a slightly stronger mixing with 5f than with 6d orbitals. This small central atom fraction seems to be a direct consequence of their parameterization which leads to exaggerated ionicity. There is no similar a priori decision towards ionic bonding in our treatment. We also note a much too narrow manifold of the topmost 32 filled ligand derived levels. Using the REX results we derive a value of only two-thirds of our quasi-relativistic $X\alpha$ -SW value; the latter value seems to be more in accord with the photoelectron spectrum (vide infra).

We next compare the results of the quasi-relativistic calculations for the series $M(C_8H_8)_2$, $M = Ce, Th, U$. The lowest unoccupied and those occupied levels which we will eventually connect with ionization potentials below 20 eV are shown in Fig. 2. One may deduce a large degree of similarity between the electronic structures of the various compounds, differing mainly in the occupation of the $e_{3u}(f)$ ligand field level. This level is unoccupied in the closed-shell systems of thorocene and cerocene, and contains two electrons in uranocene. Ligand derived σ -type orbitals are found to have virtually identical energies for all compounds; the differing positions of the π -type orbitals reflect the varying degree of ligand-metal interaction. As in ferrocene¹⁹ one finds the highest of these σ -MOs ($e_{3g}, e_{3u}; e_{2u}, e_{2g}$) with energies comparable

to the lowest π -MOs a_{2u} and a_{1g} .

The most remarkable single feature of the level spectra in Fig. 2 is the large HOMO-LUMO gap found for thorocene as compared to the corresponding $e_{2u}(\pi) - e_{3u}(f)$ energy difference of uranocene. However, if we assign the strong optical absorption^{3d} of thorocene at 2.75 eV and of uranocene at 2.01 eV to the ligand-metal charge transfer excitation $e_{2g}(\pi) \rightarrow e_{3u}(f)$ we find excellent agreement with calculated orbital energy differences: 3.03 eV for thorocene and 1.97 eV for uranocene. These values are greatly improved over those derived from the non-relativistic calculation⁴ (1.93 eV and 1.19 eV, respectively). Unfortunately, no optical spectrum has yet been reported for cerocene.

The ligand field splitting, $e_{3u}(f) - e_{2u}(f)$, is much smaller in cerocene than in both thorocene and uranocene, indicative of more ionic, less covalent bonding in the Ce compound. This result is not in disagreement with the limited chemistry reported for this compound.⁶ The absolute values, however, turn out to be larger than assumed in ligand field based treatments of these systems.¹⁷ We find 0.77 eV, 1.54 eV and 1.27 eV for Ce, Th and U, respectively.

The experimental ionization potentials as determined from photoelectron spectroscopy (PES)²⁰ are compared in Table 1 with our calculated values. The overall agreement is rather satisfactory. To simplify the presentation in Table 1 only average values are given for those pairs of ligand derived MOs which show a splitting of 0.15 eV or less.

The calculated level ordering among the highest occupied MOs, $e_{2u} > e_{2g}$, confirms the PES interpretation of Clark and Green.^{20c} The corresponding energy differences found in the quasi-relativistic calculation reproduce the experimental absolute relative values (thorocene > uranocene) so well (see Table 2) that a reverse assignment would now seem highly improbable.^{20d}

The next band in the PE spectrum consists of three peaks and has been identified with ionization from the e_{1g} , e_{1u} pair of [8]annulene π -type orbitals.^{20c} Here, too, the quasi-relativistic results show improved agreement. This becomes especially clear when we consider energy differences as in Table 2.

In the next very broad and intensive band of the PE spectra only two peaks have been discriminated. Our calculations support the assignment to the lowest ligand π -type MOs a_{2u} and a_{1g} and the highest σ -type MOs. No explicit assignment for these and the higher ionization potentials in the PE spectra has been given.²⁰ We therefore present only estimates for the transition state energies of the levels below the $a_{1g}(\pi)$ MO. Our calculations corroborate the experience that orbitals of similar character undergo rather uniform relaxation shifts which are correlated with the electron self-energy (e.g., the Coulomb integral). These higher ionization potentials are derived from ground state orbital energies by applying a uniform relaxation shift of 2.0 eV which we found for the high-lying e_{2g} , e_{3u} , e_{2u} and e_{2g} σ -type MOs. In Table 1 we present a tentative assignment for the higher ionization potentials based on the experience that we must allow errors from the $X\alpha$ -SW method of the order of 1 eV.¹⁹ Especially, manifolds of π -type orbitals tend to become too compressed²¹ resulting in calculated ionization potentials which are too small. In this context we would like to point out the fact that only one set of muffin-tin parameters has been used throughout with one judicious adjustment in advance based on previous experience.^{4, 22} With additional fitting, although costly in computer time, improved results might be obtained.

The value of 5.75 eV for the lowest ionization potential of uranocene is in good agreement with the experimental result of 6.30 eV, particularly since spin-orbit interaction has been neglected. Such interaction will clearly be

significant in this highly localized orbital which shows a f-electron population of 0.91 in the metal sphere. In the relativistic $X\alpha$ calculation for the uranium atom one finds a $f_{5/2}-f_{7/2}$ splitting of 0.78 eV. One therefore expects from perturbation theory a corrected value of approximately 6.1 eV in satisfactory agreement with experiment, moreover, there is expected to be an additional splitting in the final state with different cross sections for ionization.^{23,24} Consequently, the apparently better result of the non-relativistic calculation⁴ is not meaningful.

A close comparison of the non-relativistic⁴ and the present quasi-relativistic transition state energies shows a reduction of the ionization potentials - corresponding to an upward shift of the orbital energies - only for the $e_{2u}(\pi)$ MO both of thorocene and uranocene and for the $e_{3u}(f)$ MO of uranocene. This may be traced to the relativistic expansion of the uranium 5f orbitals and brings us to a discussion of the bonding in uranocene and thorocene.

This work, too, confirms the contribution of the metal $f_{\pm 2}$ orbitals to the ring-metal bonding just as suggested originally in the first preparation of uranocene.² The metal involvement in the bonding $e_{2u}(\pi)$ orbital leads to a lowering as compared to the [8]annulene "dimer" (see Fig. 1). The corresponding antibonding partner $e_{2u}(f)$ ends up as the highest ligand field level. The $e_{2u} - e_{2g}$ splitting (0.98 eV for the calculated ionization potentials of thorocene, 0.71 eV for uranocene) is somewhat larger than found from direct, ligand-ligand interaction without involvement of metal orbitals, which is 0.62 eV in the "dimer" (see Table 2). This result points to a comparable bonding contribution of the $6d_{\pm 2}$ metal orbitals to the $e_{2g}(\pi)$ MO, confirming our previous analysis.⁴

Our calculations reproduce the experimentally found²⁰ lesser $e_{2u} - e_{2g}$ splitting for uranocene compared to thorocene (see Table 2). This result has been connected to a greater f-orbital covalency in the uranium compound.^{4,20c} However, this interpretation is conclusive only on the basis of equal d-orbital covalency in

both compounds. But our calculation fully supports this necessary additional assumption. The d-wave population of the metal sphere in the $e_{2g}(\pi)$ MO is almost equal for both compounds (uranocene: 0.20, thorocene: 0.21). The f-wave population in the $e_{3u}(\pi)$ MO, on the other hand, has a substantially larger value in uranocene (0.33) than in thorocene (0.20).

A further contribution to ring-metal bonding is provided by the $e_1 - d_{\pm 1}$ interaction.⁴ The e_{1u} , e_{1g} MOs of the "dimer" are lowered by the bonding interaction with the metal orbitals but much less than the e_{2u} , e_{2g} MOs (see Fig. 1). The energy differences to the $e_{2u}(\pi)$ MO are therefore reduced when compared to the "dimer", as can be seen from Table 2. The level ordering $e_{1u} < e_{1g}$ in the "dimer" is reversed to $e_{1u} > e_{1g}$ in both uranocene and thorocene (Fig. 2), indicating a substantial bonding character at least for the e_{1g} MO. Almost identical metal populations are found for uranocene and thorocene (0.07 e_{1u} , 0.10 for e_{1g}). The level splittings are again well reproduced, both in absolute and relative magnitude: 0.67 eV for thorocene, 0.51 eV for uranocene compared to the experimental values, 0.75 eV and 0.61 eV, respectively (see Table 2). We note, however, that the photoelectron spectra of several substituted uranocenes have been interpreted in terms of the level ordering $e_{1u} < e_{1g}$ in disagreement with these theoretical results.²³ We have no explanation at this time for this apparent discrepancy.

The results of this work based on a quasi-relativistic treatment essentially confirm but put on firmer ground our previous conclusions⁴ on the ring-metal bonding in uranocene and thorocene: metal 5f and 6d orbitals contribute significantly to this bonding, mainly through their interaction with the high-lying e_2 π -MOs of the two [8]annulene rings, but also to a lesser extent through interaction with the subjacent e_1 π -MOs. The good overall agreement with experiment lends confidence to the quasi-relativistic $X\alpha$ -SW method. We would not expect the inclusion of spin-orbit interaction to alter the resulting coherent picture in any major way. Indeed, Amberger²⁵ has recently found that crystal

field parameters derived from the energy levels reported here give electronic ground states for uranocene, neptunocene and plutonocene that agree with magnetic data.

Acknowledgement

This work was supported in part by NATO grant no. 1237. N. R. is supported by the Deutsche Forschungsgemeinschaft and by the Fonds der Chemischer Industrie. A.S. is supported in part by the Director, Office of Energy Research, Office of Basic Energy Sciences, Chemical Sciences Division of the U.S. Department of Energy, under Contract No. DE-AC03-76SF00098.

Comparison of quasi-relativistic X α transition state orbital energies with the photoelectron spectrum of thorocene and uranocene.

Irred. repr.	Thorocene		Uranocene	
	calc.	exp. ^a	calc.	exp. ^a
e_{3u} (f)			5.75	6.20
e_{2u} (π)	6.53 ^b	6.79	6.57	6.90
e_{2g} (π)	7.51	7.91	7.29	7.85
e_{1u} (π)	9.44	9.90	9.43	9.95
		10.14		10.28
e_{1g} (π)	10.11	10.65	9.94	10.56
a_{2u} (π)	10.55		10.55	
e_{3g}, e_{3u}	10.61	11.48 ^c	10.52	11.50 ^c
e_{2g}, e_{2u}	10.90		10.93	
a_{1g} (π)	11.68	12.32	11.62	12.37
b_{2g}, b_{1u}	12.19 ^d	14.12	12.10 ^d	14.09
e_{1g}, e_{1u}	13.65	14.65	13.53	14.67
a_{2u}	14.62		14.49	
		16.17		16.10
a_{1g}	15.12		15.01	
b_{1g}, b_{2u}	15.80	16.74	15.67	16.73
e_{3g}, e_{3u}	17.78	17.91	17.65	17.85

^a Ref. 20c.

^b All energies in eV.

^c No explicit assignments are given in ref. 20c for this and all higher ionization potentials.

^d This and all higher transition state energies are estimated from ground state orbital energies by applying a relaxation shift of 2.0 eV.

Table 2

Comparison of calculated and measured ionization energy differences with respect to the ligand derived $e_{2u}(\pi)$ molecular orbital for $(C_8H_8)_2$ and the series $M(C_8H_8)_2$, $M = Ce, Th, U$. Only experimentally assigned peaks are considered.

Irred. repr.	$(COT)_2$	$Ce(COT)_2$		$Th(COT)_2$			$U(COT)_2$		
	non-rel.	non-rel.	qu.-rel.	non-rel. ^a	qu.-rel.	exp. ^b	non-rel. ^a	qu.-rel.	exp. ^b
$e_{3u}(f)$							-0.53 ^c	-0.82	-0.70
$e_{2u}(\pi)$	0	0	0	0	0	0	0	0	0
$e_{2g}(\pi)$	0.62	0.77	0.89	0.64	0.98	1.12	0.17	0.71	0.95
$e_{1u}(\pi)$	4.16	2.99	3.11	2.53	2.91	3.11	2.28	2.86	3.05
$e_{1g}(\pi)$	3.62	3.45	3.53	3.30	3.58	3.86	2.91	3.37	3.66

^a Ref. 4.

^b Ref 20c .

^c All energies in eV.

Fig. 1

Comparison of non-relativistic and quasi-relativistic SCF-X α -SW orbital energies for uranocene. Solid lines represent occupied MOs, dashed lines empty MOs. The non-relativistic and relativistic orbital energies for the uranium atom and the orbital energies for the neutral [8]annulene dimer (C₈H₈)₂ are also shown.

Fig. 2

Comparison of quasi-relativistic SCF-X α -SW orbital energies for the series M(C₈H₈)₂, M = Ce, Th, U.

References

- (1) (a) This work was supported in part by NATO grant No. 1237.
(b) Permanent address: Materials and Molecular Research Division, Lawrence Berkeley Laboratory, and Department of Chemistry, University of California, Berkeley, CA 94720 USA; supported in part by the Director, Office of Energy Research, Office of Basic Energy Sciences, Chemical Sciences Division of the U.S. Department of Energy, under Contract No. DE-AC03-76SF00098.
- (2) Streitwieser, A. Jr.; Müller-Westerhoff, U. J. Am. Chem. Soc. 1968, 90, 7364.
- (3) (a) Streitwieser, A. Jr. in Topics in Non-Benzenoid Aromatic Chemistry Vol. 1, Nozoe, T.; Breslow, R.; Hafner, K.; Ito, S.; Murata, I. Eds., Hirokawa, Tokyo, 1971, p. 221.
(b) Baker, E. C.; Halstead, G. W.; Raymond, K. N. Structure and Bonding, 1976, 25, 23.
(c) For recent reviews see Marks, T. J.; Fischer, R. D. (Eds.), Organometallics of the f-Elements, NATO ASI series c, v. 44, Reidel, Dordrecht, 1979; especially:
(d) Streitwieser, A. Jr., p. 149.
(e) Raymond, K. N., p. 249.
- (4) Rösch, N.; Streitwieser, A. Jr., J. Organometal. Chem. 1978, 145, 195.
- (5) For a review of relativistic quantum chemistry see P. Pyykkö, Adv. Quantum Chem. 1978, 11, 353.
- (6) Greco, A.; Cesca, S.; Bertolini, G.; J. Organometal Chem. 1976, 113, 321.
The compound had been reported earlier (Kalsotra, B. L.; Multani, R. K.; Jain, B. D. Chem. and Ind. 1972, 339) but the infrared spectrum in the earlier report is totally different.
- (7) Thornton, G.; Rösch, N.; Edelstein, N. Inorg. Chem. 1980, 19, 1304.
- (8) Slater, J. C. The Self-Consistent Field for Molecules and Solids, McGraw-Hill, New York, 1974.

- (9) Koelling, D. D.; Ellis, D. E.; Bartlett, R. J. J. Chem. Phys. 1976, 65, 3331.
- (10) For a review see Rösch, N. in Electrons in Finite and Infinite Structures, NATO ASI series B, v. 24, Phariseau, P.; Scheire, L. (Eds), Plenum Press: New York, 1977, p. 1.
- (11) Liberman, D. A.; Waber, J. T.; Cromer, D. T. Phys. Rev. 1965, A137, 27.
- (12) Yang, C. Y.; Rabi, S. Phys. Rev. 1975, A12, 362.
- (13) Cowan, R. D.; Griffin, D. C. J. Opt. Soc. Am. 1976, 66, 1010.
- (14) Boring, M.; Wood, J. H. J. Chem. Phys. 1979, 71, 32.
- (15) Shannon, R. D.; Prewitt, C. T. Acta Cryst. 1969, B25, 925.
- (16) Schwarz, K. Phys. Rev. 1972, 85, 2466; Theor. Chim. Acta, 1974, 34, 225.
- (17) (a) Hayes, R. G.; Edelstein, N. J. Am. Chem. Soc. 1972, 94, 8688.
(b) Warren, K. D. Structure and Bonding 1977, 33, 97.
- (18) Pyykko, P.; Lohr, L. L. Inorg. Chem. 1981, 20, 1950.
- (19) Rösch, N.; Johnson, K. H. Chem. Phys. Lett. 1974, 24, 179.
- (20) (a) Clark, J. P.; Green, J. C. J. Organometal. Chem. 1976, 112, C14.
(b) Fragala, I.; Condorelli, G.; Zanella, P.; Tondello, E. J. Organometal. Chem. 1976, 122, 357.
(c) Clark, J. P.; Green, J. C. J. Chem. Soc. Dalton, 1977, 505.
(d) Fragala, I. in ref. 3c, p. 421.
- (21) Liberman, D. A.; Batra, I. P. J. Chem. Phys. 1973, 59, 3723.
- (22) (a) Rösch, N.; Klemperer, W. G.; Johnson, K. H. Chem. Phys. Lett. 1973, 23, 149.
(b) Herman, F.; Williams, A. R.; Johnson, K. H. J. Chem. Phys., 1974, 61, 3508.
- (23) P. A. Cox, Structures and Bonding 1975, 24, 59; Egdell, R. G.; Orchard, A. F.; Lloyd, D. R.; Richardson, N. V. J. Electron Spectrosc. Relat. Phenom. 1977, 12, 415.
- (24) Green, J. C.; Payne, M. P.; Streitwieser, A. Jr., manuscript in preparation.
- (25) H. D. Amberger, personal communication.

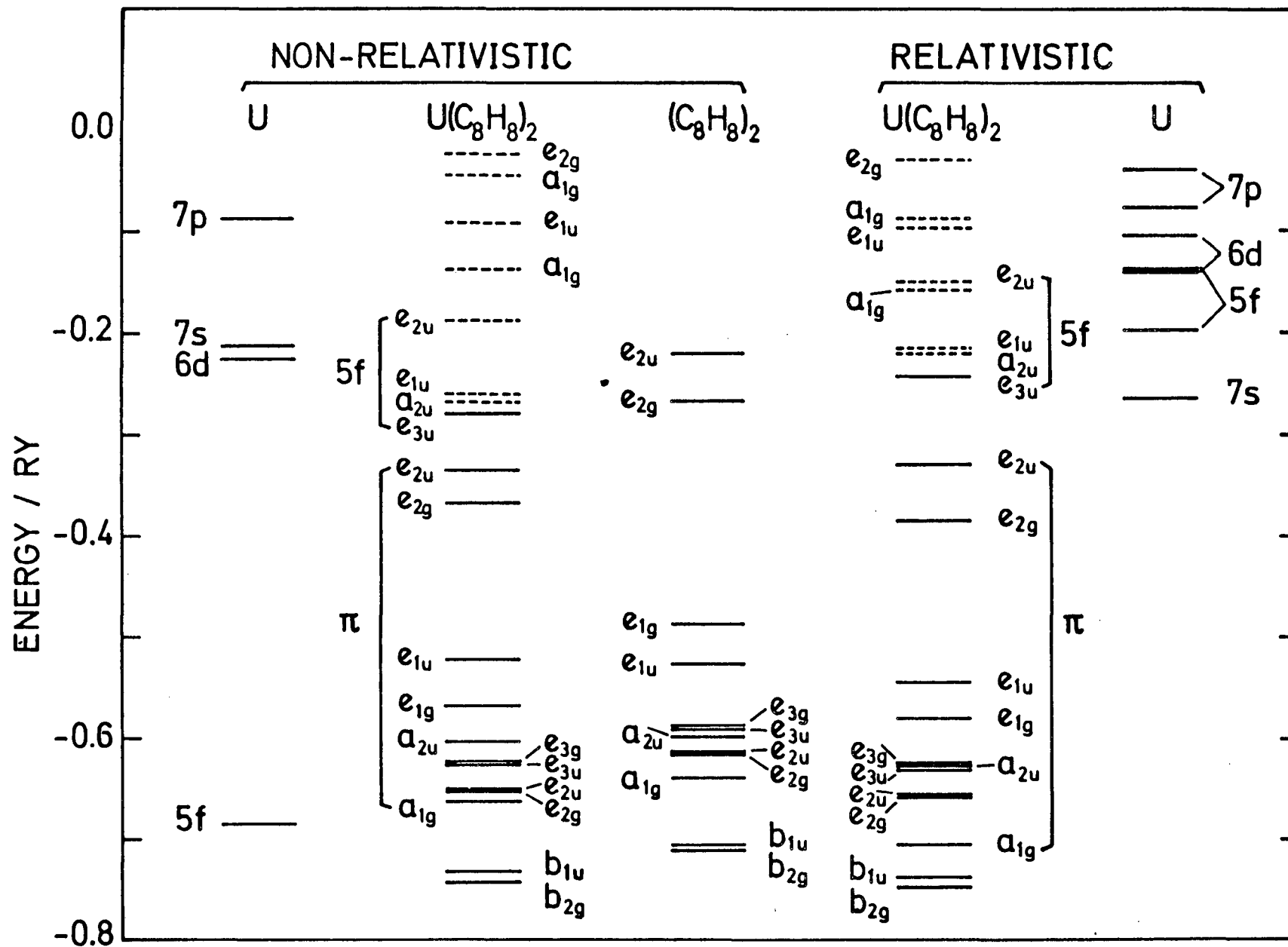

This report was done with support from the Department of Energy. Any conclusions or opinions expressed in this report represent solely those of the author(s) and not necessarily those of The Regents of the University of California, the Lawrence Berkeley Laboratory or the Department of Energy.

Reference to a company or product name does not imply approval or recommendation of the product by the University of California or the U.S. Department of Energy to the exclusion of others that may be suitable.

TECHNICAL INFORMATION DEPARTMENT
LAWRENCE BERKELEY LABORATORY
UNIVERSITY OF CALIFORNIA
BERKELEY, CALIFORNIA 94720