

Lawrence Berkeley National Laboratory

LBL Publications

Title

Center for Building Science News

Permalink

<https://escholarship.org/uc/item/410878vx>

Author

Lawrence Berkeley National Laboratory

Publication Date

1993-02-01

Copyright Information

This work is made available under the terms of a Creative Commons Attribution License, available at <https://creativecommons.org/licenses/by/4.0/>

DISCLAIMER

This document was prepared as an account of work sponsored by the United States Government. While this document is believed to contain correct information, neither the United States Government nor any agency thereof, nor the Regents of the University of California, nor any of their employees, makes any warranty, express or implied, or assumes any legal responsibility for the accuracy, completeness, or usefulness of any information, apparatus, product, or process disclosed, or represents that its use would not infringe privately owned rights. Reference herein to any specific commercial product, process, or service by its trade name, trademark, manufacturer, or otherwise, does not necessarily constitute or imply its endorsement, recommendation, or favoring by the United States Government or any agency thereof, or the Regents of the University of California. The views and opinions of authors expressed herein do not necessarily state or reflect those of the United States Government or any agency thereof or the Regents of the University of California.

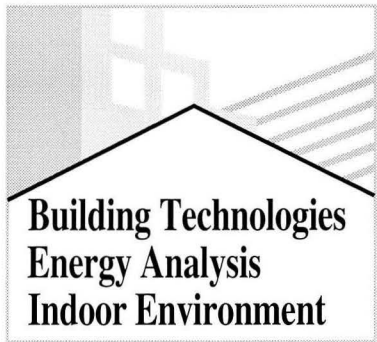

Center for building science News

Premier Issue

LAWRENCE BERKELEY LABORATORY

ENERGY & ENVIRONMENT DIVISION • WINTER 1993

Twenty Years of Energy and Environment

During a day of reminiscing and looking ahead, LBL's Energy & Environment Division—home of the Center for Building Science—celebrated its twentieth year on November 1. Established less than two weeks after the first OPEC oil embargo began in 1973, E&E was born into a world that was learning spectacular lessons about the effects of unrestrained energy consumption on the environment and the economy.

Guest speakers at the all-day anniversary forum included Susan Fallows Tierney, DOE's assistant secretary for policy, planning, and program evaluation; Jack Hollander, the Division's first director; Andy Sessler, former LBL director; Bob Budnitz, the Division's second director; Charles Shank, LBL's current director; and Paul Witherspoon, professor emeritus, Materials Science and Mineral Engineering, U.C. Berkeley. Fifteen former and current Division scientists and program directors, including Art Rosenfeld, the Center for

Building Science's director, reminisced about the early years. Assistant secretary Tierney described DOE's current efforts to devise a framework supporting a strong energy future for America. Guest speakers—including Guillermo Fernandez de la Garza, technical secretary of Mexico's National Commission for Energy Efficiency; David Goldstein, energy program director, Natural Resources Defense Council; David Jhirad, senior energy advisor at the US Agency for International Development; Amory Lovins, director of



Susan Fallows Tierney, DOE's assistant secretary for policy, planning, and program evaluation, describes new planning initiatives at the E&E anniversary forum.

research at the Rocky Mountain Institute (via videotape); and Susan Maxman, president of the American Institute of Architects—discussed the future of energy efficiency in California, the nation, and the world.

The speakers emphasized one message: with greenhouse-gas emissions a major environmental concern and energy demand rising, especially in developing nations, energy efficiency is once again a prominent player on the stage set by the OPEC oil embargo 20 years ago.

Not Cool to Be Hot

4 Fluorescent lamps run up to 15% more efficiently with technology developed at LBL.

Appliance Surveys

6 Residential appliance saturation surveys furnish information about the growth of energy-efficiency measures.

Airvest

7 A new invention lowers workers' exposure to hazardous sprays while saving ventilation energy.

On the Energy Edge

10 Energy-saving buildings in the Pacific Northwest are teaching scientists new tricks.

Caltrans Retrofit

11 The California Department of Transportation retrofits its Marysville office's lighting with the Center's help.

Departments

A Viewgraph from the Director	2
News from the D.C. Office	3
Energy Education	8
Technology Transfer	9
Center Research Facilities	12
Hot Off the Press	13
Visitors Far and Wide	14
Energy Currents	15
Awards and Citations	16

PUB 731

REFERENCE COPY
Does Not Circulate

PUB-731

Copy 1

Bldg. 50 Library.

About the Center

Addressing increasingly critical energy-related issues, the Center for Building Science has become an international leader in developing and commercializing energy-efficient technologies and analytical techniques and documenting ways of improving the energy efficiency and indoor environment of residential and commercial buildings.

The Center is the home of three Energy & Environment Division programs—Building Technologies, Energy Analysis, and Indoor Environment. It serves as a national and international voice for energy efficiency, provides technical support to energy and environmental policymakers, supports and creates institutions and demonstration programs, provides a training ground for students in the energy field, and facilitates transfer of technology and information to the private sector.

Researchers in the Center recognize that despite significant, steady progress since the energy crises of the 1970s, a large potential for energy savings remains to be realized. The Center's interdisciplinary staff studies a wide spectrum of environmental, economic, and technical aspects of energy-efficiency activities, recognizing that energy efficiency is a new and highly cost-effective energy resource.

Director Art Rosenfeld
 Assistant Director Evan Mills
 Program Leaders:
 Building Technologies Program Steve Selkowitz
 Energy Analysis Program Mark Levine
 Indoor Environment Program Joan Daisey

Ordering Information

If you would like to receive this newsletter, correspond, or receive a comprehensive publication list for the Center's programs, please write to:

Center for Building Science News
 Attn: Ralph McLaughlin
 Mail Stop 90-3058
 Lawrence Berkeley Laboratory
 University of California
 Berkeley, CA 94720 USA
 Tel: (510) 486-4508
 Fax: (510) 486-5394



A Viewgraph from the Director

Global Warming Warning

“Don't Fool with the Climate”

I am pleased to be able to bring you this column for the premier issue of our newsletter because it's an opportunity to present the Center's current favorite viewgraph. I hope that readers who decide the information presented here is useful will pass it along to others.

Everything we develop at the Center, from hardware to policy, is aimed at saving energy and money through investments that will pay for themselves in a short time. In a rational market, these ideas sell themselves. But we now know that even before the 1973 oil embargo, when the payback time for improved automobile fuel efficiency was less than a year, the idea attracted monumental disinterest. Many good ideas suffer from this apathy—preventive medicine, gun control, and hundreds of other examples. In the irrational real world, a commitment to energy efficiency is probably awaiting at least two or three hot, dry summers accompanied by significant agricultural losses and wildfires—climate effects that would heighten the sense of urgency to reduce greenhouse-gas emissions.

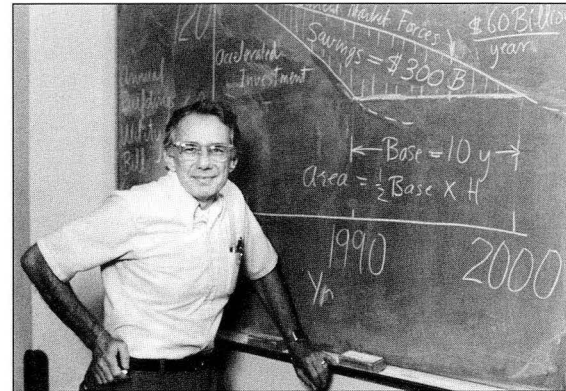

Art Rosenfeld

...no one foresaw that the new cores would reveal a climatic flickering of great frequency and magnitude...

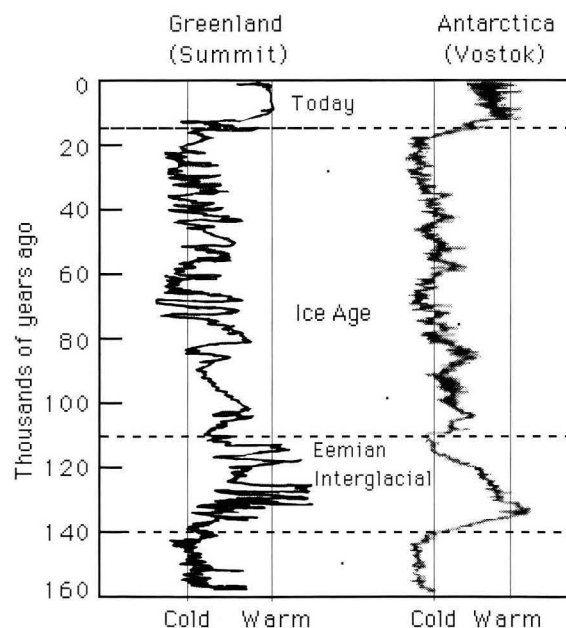

Until the spring of 1993, climatologists tended to talk more about “global” warming than regional changes, which might manifest themselves as warming or cooling, and as droughts or floods. Our best information on Earth's earlier climates came from a single source: the record of past temperatures locked in the Vostok ice core from Antarctica. The consensus was that the doubling of CO₂ would raise the global average temperature by 2-5°C, a change comparable to the global cooling of about 4°C during the last ice age. This kind of talk is scary, since

Continued/ A Viewgraph from the Director

that 4° difference had great implications: the ice above New York during the last ice age was one to two kilometers thick ("Manhattan, the mile-high city"), Canadian spruce grew along the Caribbean, and if there was land suitable for wheat and corn cultivation it was probably in Mexico.

But now there's even scarier news in an article by J.W.C. White in the 15 July 1993 issue of *Nature* (364, 186). When ice-core drilling moved from dry Antarctica to snowy Greenland to get better time resolution, no one foresaw that the new cores would reveal a climatic "flickering" of great frequency and magnitude. Temperature changes amounting to plus or minus half the ΔT of entire the ice age happened in 25 years or less during the last interglacial (the "Eemian"), when—according to Vostok—the climate should have been as stable as it is today. The Greenland Summit and Antarctic Vostok core data are compared in the diagram to the left that depicts oxygen isotope measurements, a close proxy for temperature.

One explanation is that Greenland is on the receiving end of the Gulf Stream, which dominates the climate, and therefore the agriculture of both eastern North America and western Europe. The Gulf Stream seems to have turned on and off, producing in a single decade climate changes comparable to the glacial-interglacial transition.

If Vostok suggested that climate was somewhat stable during interglacial periods in Antarctica, the new Summit core shows that the current interglacial—the time in which we live—is a distinct anomaly. It now looks as if agriculture and Western civilization may have developed during the only known window of climate stability on record. Both the most recent glacial era *and the Eemian interglacial era* underwent a climate flickering that we would consider catastrophic. To adapt to extreme changes like that, ecosystems and agriculture would have to move an impossible thousands of miles per decade. Of course, we could all move to some warmer, more stable part of the globe, if we could figure out where that will be and if a few billion other people haven't gotten there first. So I tend to agree with J.W.C. White: let's not fool with the fossil fuel-based switch that can turn off climate stability. 

The Center for Building Science News

Published Quarterly
Vol. 1, No. 1

Executive Editor
Evan Mills

Managing Editor
Allan Chen

Contributing Editors

Nathan Martin
Karen H. Olson
Rich Sextro
Michael Wilde

Production/Design
Malcolm Love

Copy Editors
Linda Comer
Ann Kelly

Circulation
Ralph McLaughlin
Pat McLaughlin

News from the D.C. Office

Our D.C. Office is Open!

The Washington, D.C., office of LBL's Energy & Environment Division opened its doors in May 1993. It is headed by Stephen Wiel, who joined LBL in 1992 with the mission of establishing the D.C. office.

He served eight years as a public service commissioner in Nevada, during which he distinguished himself as chairman of NARUC's Conservation Committee for almost four years. Steve is assisted by Jeffrey Harris, who had been in Washington on temporary assignment to DOE and is remaining on permanent assignment to the D.C. office. The two are supported by Moira Howard as office manager.

LBL's Energy & Environment Division established the office to gain a better understanding of the needs and desires of its clients through closer contact and to help researchers in the Division design and conduct projects in ways that better satisfy client needs. The office will also house project work that can be performed more efficiently in D.C. and, of course, will provide administrative support to Berkeley staff members during their frequent trips to Washington.

The office actually conducted its first business even before it opened.

On the Friday afternoon before the first day of operations, Steve met with two visitors from the International Energy Agency there. During this meeting, Steve also fielded the office's first official phone call. The voice on the phone asking for Art Rosenfeld's fax number turned out to be a White House staff member who had "gotten the number from information."

The new office suite was remodeled to showcase state-of-the-art, energy-efficient lighting, office equipment, and other end uses. The 25-person conference room is available to anyone who would like to use it for a purpose consistent with the Division's mission. The office is located near DOE's Forrestal building at 1250 Maryland Ave. SW, Suite 150, Washington, D.C. 20024; the phone number is (202) 484-0880 and the fax number is (202) 484-0888. 



The Cutting Edge

Not Cool to Be Hot

Heat generated in fluorescent luminaires can result in 15% to 20% less light output and reduced efficacy. To overcome the problem, manufacturers are adopting design solutions developed by LBL researchers.

The actual light output and energy use of regular and compact fluorescent lighting systems can be significantly different from labeled (optimal) values. The key is temperature.

The notion of thermal efficiency has long been understood, but it's often neglected in luminaire design. Temperatures inside fluorescent fixtures are important because excess mercury condenses at the coldest point on a lamp, regulating light output and (for long fluorescent lamps) power consumption. Suboptimal temperatures lead to losses in light output. Lamp temperature depends on lamp and fixture geometry, wattage, ballasting, ambient temperature, lamp orientation, and air circulation.

A frequent criticism of compact fluorescent lamps (CFLs)—“not enough light”—can be traced partly to overheating. This arises because of lamp orientation or because CFLs are used in fixtures designed for incandescent lamps, where temperature does not affect light output. Other unwanted

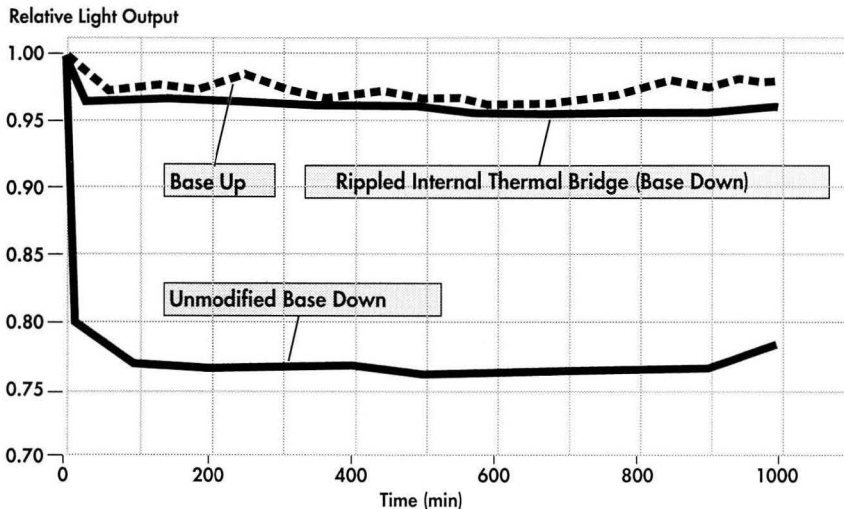

The base-up alternative produces almost 100% of the rated light output. The light output from the base-down CFL decreases by almost 25% after a few minutes of operation. However, by adding a thermal bridge (see opposite photos), the performance of the base-down CFL improves dramatically.

side effects may include color shifts toward blue-green, reduced color rendering, and shortened system life.

Because power consumption decreases as temperature increases in long-tube fluorescent systems, thermal factors make it hard to design and calculate

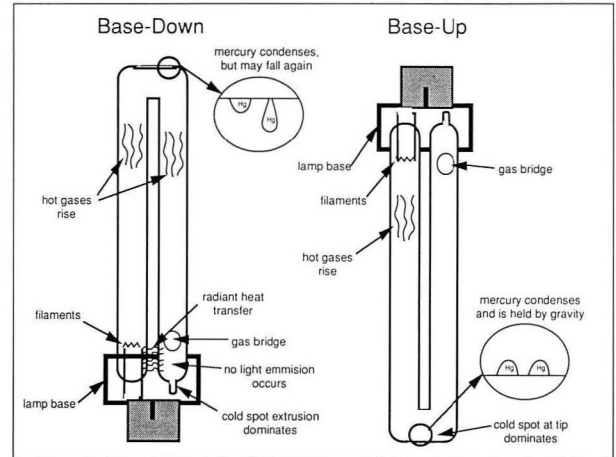

Compact fluorescent lamp

energy savings from changes in these lamps. A pre-retrofit system may operate far from the optimal temperature, while the post-retrofit system may run at or near the optimum. Reasons for this include fewer or lower-wattage lamps and ballasts in the post-retrofit fixture and better ventilation characteristics. CFLs do not exhibit the same reduction in power as do long fluorescents and, as a result, efficacy (lumens/watt) diminishes dramatically as temperature increases.

Beating the Heat

A variety of clever strategies have been devised to optimize the thermal performance of fluorescent lighting systems. These include modifying lamps (conductive cooling) and fixtures (convective cooling). Another approach is to use mercury amalgams. They have not been widely adopted by lamp manufacturers because they can complicate the manufacturing process and be more costly than thermal management strategies.

For long-tube fluorescent systems, one of the technologies developed by Center researchers is a “spot cooler” that can be inserted so that it rests lightly against the top of the lamp (or beneath the lamp in an indirect pendant fixture). When applied to F40 lamps in enclosed wraparound fixtures, this strategy increases in light output by 15% and efficacy by 8%. A number of manufacturers are now planning to integrate spot coolers with their luminaires.

Thermal factors are also responsible for the fact that CFLs operating in a base-down position produce 15% to 20% less light (with a comparable reduction in lumens/

watt) than when used in a base-up position. This is because excess mercury drips from the cold spot at the top of the lamp into the hot glass tubulation in the base, where it is re-vaporized. Work at LBL shows that a small copper strip fitted around the tubulation rapidly conducts heat away from the lamp, achieving up to 99% of rated light output (see photo and graph).

Another approach to thermal management is to increase air movement around the lamps. One solution is fan-based systems, but these are relatively costly, use extra energy, and require maintenance. A simpler strategy is to modify fixtures so that they are passively cooled. Researchers at LBL increased the light output of prototype recessed CFL downlights by adding up to 20% simply by adding ventilation slots. Proper slot size and positioning are critical because excessively large openings result in optical losses that offset part of the benefits related to lower

“Prototype recessed CFL downlights developed at LBL have increased light output by up to 20% simply by adding ventilation slots.”

temperatures. The optimized, vented fixtures have only 1% to 2% optical losses and are manufactured by Delray, Edison Price, Indy Lighting, Lightolier, Lithonia, Microflect, Prescolite, Reggiani, Staff, and Zumtobel.

The most effective solution yet identified requires tilting the lamp downward by 5 to 10°C. This

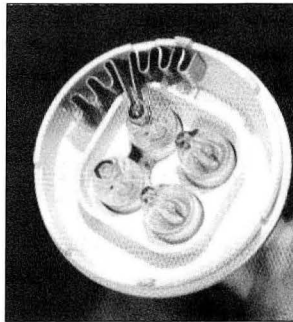
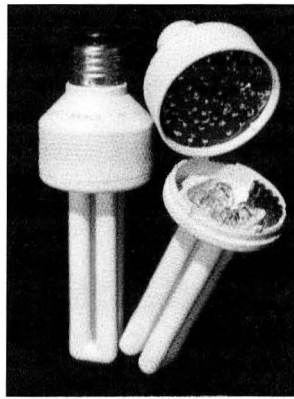

A rippled copper strip attached to the glass tubulation in a CFL rapidly conducts heat away from the lamp.

places the tip in a cooler part of the fixture, allowing the mercury to settle to the tip more easily and improving the air flow.

One concern about convective ventilation is the potential for increased dirt buildup on the lamp and fixture, leading to reduced light output over time. In experiments conducted at LBL, dust was injected into a controlled chamber containing vented and unvented fixtures. Candlepower readings taken one meter below the fixtures revealed that vented fixtures had consistently less lumen depreciation over time than unvented ones. This may be because dust leaves the ventilated fixture before it has a chance to settle.

The measures described here are expected to add very little, if anything, to the production cost of lamps or fixtures. Convective venting adds virtually nothing to the cost of CFL downlights; conductive cooling in the lamp base costs about 10¢ per lamp; and spot coolers add about \$5 per fixture. The resulting cost-performance tradeoff is increasingly viewed by lamp and luminaire manufacturers as an attractive opportunity for increasing the competitiveness of their products in markets where achieving higher lumen output is the name of the game.

Evan Mills

Adapted from a version published in the IAEEEL Newsletter, no. 2/93.



Michael Siminovitch or Chin Zhang
Lighting Research Group
Building Technologies Program
(510) 486-5863, Fax: (510) 486-6940

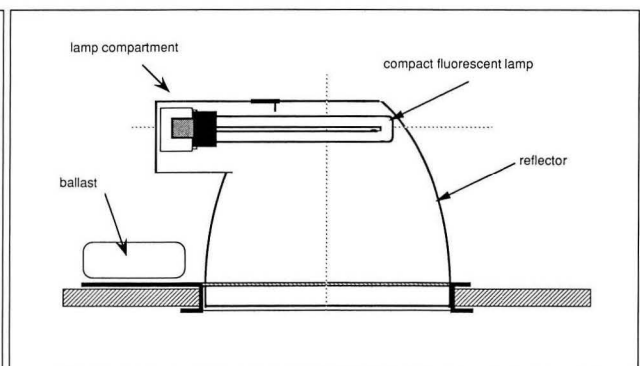
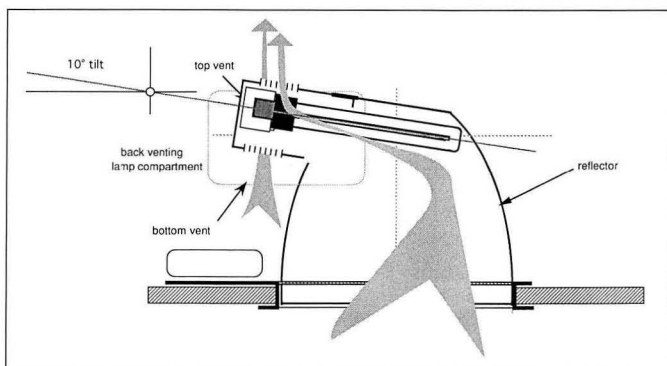

Standard recessed fixture (left) and modifications (passive ventilation slots and tilted lamp) to achieve optimal thermal performance.

The Cutting Edge

Progress in Residential Retrofit

Many utilities survey their customers to learn more about the buildings and the occupants in their service areas. These surveys—usually called “residential appliance saturation surveys,” or RASSes—ask for the number and types of appliances present, the number of people living in the home, and sometimes personal information.

The RASSes are also used to collect information about the presence of conservation measures such as wall and ceiling insulation, weatherstripping, multipane windows, and water flow restrictors. Building Energy Analysis Group researchers Alan Meier and Brian Pon gathered RASSes from more than 100 utilities for recent research on the nation’s progress in residential retrofit. This compilation represents nearly 80 million residential customers, or approximately 80% of the nation’s households. Average saturation levels of conservation measures were calculated from these RASSes.

The principal advantage of using RASSes is that each RASS surveys a large number of consumers. When data from the RASSes are aggregated nationally or regionally, their sample size is far greater than that of analogous nationwide surveys, which typically survey only a few thousand customers. Another advantage is the low cost of obtaining them: usually only a letter and a phone call are required to complete the survey. Unfortunately, the inconsistent questions and wording among the RASSes collected from the various utilities make it difficult to aggregate the data.

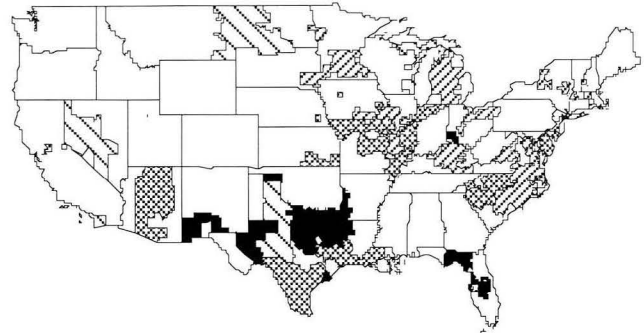

Percent of homes with ceiling fans

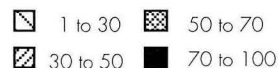

A geographic representation of saturations of ceiling fans based on data from the RASSes. White areas indicate a lack of data for that region.

The figure on the left shows the saturation of ceiling fans across the nation. Although most utilities did not ask their customers if they had ceiling fans, enough did ask that the variation among regions is detectable. In fact, the saturation of ceiling fans appears to be very dependent on region. Saturation levels are 50% or greater in the South and in the Mississippi and Ohio River valleys. The use of ceiling fans in the homes of these regions would influence the energy use of conventional air conditioners.

The figure above geographically represents the saturation levels of water-heater blankets. The saturation levels in various regions appear to have little correlation to climate, ranging from 8% in central Texas to 56% in one Pacific Northwest service area. The latter area’s utility conducted a free water-heater wrap program in 1989. Evidently, this program was highly successful.

Brian Pon and Alan Meier

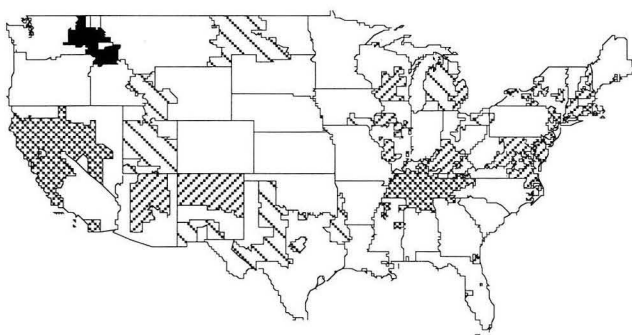

Percent of homes with water heater blankets

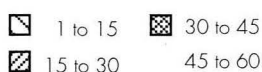

A geographic representation of saturations of water-heaters based on data from the RASSes. White areas indicate a lack of data for that region.



Brian Pon (510) 486-6829
 Alan Meier (510) 486-4740
 Building Energy Analysis Group
 Fax: (510) 486-6996

The Cutting Edge

Airvest's Breath of Fresh Air

*S*pray booths are a common sight in the industrial sector. Designed to remove pollutants during industrial processes such as spray painting or welding, a booth is a rectangular enclosure open on one side where the worker stands, and equipped on the opposite wall with a fan and filter arrangement to suck away the dirty air. The full-size mannequin in these photographs simulates a worker in a spray booth facing the exhaust filters. In experiments designed by LBL researcher Ashok Gadgil, smoke was released in front of the mannequin to simulate the spraying of paint in the booth.

The photo on the left shows the spray booth during standard operation. The smoke—representing a pollutant—is entrained in the eddy that forms in front of the mannequin, rising to the figure's breathing zone. The concentration of pollutant in the breathing zone of the mannequin was found to be about the same as the concentration at the exhaust chimney.

The photo on the right depicts the same experiment, except that the little box on the mannequin's chest is continuously ejecting a small amount of air, hence the name airvest. This arrangement, intended only as a proof-of-principle experiment, ventilates or eliminates the eddy in front of the worker, causing the smoke to jet away. The pollutant concentration at the breathing zone is reduced by 100- to 800-fold, depending on how much air is ejected from the box.

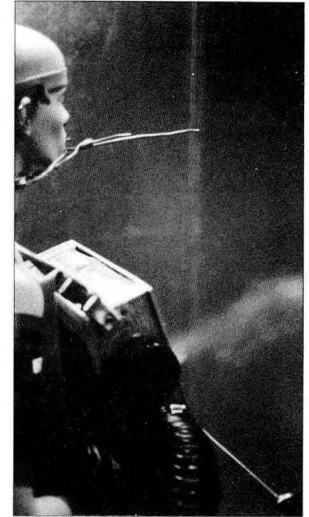

With the airvest, it appears possible to substantially reduce the fan speed in the spray booth and simultaneously reduce the worker's exposure to industrial pollutants. A reduction in spray-booth flow rate by a factor of two will result in significant energy savings—on the order of \$1,000 annually per shift per booth, depending on the local climate—from reduced heating, cooling, and filtration of the incoming make-up air. This reduction in energy use accompanies a 50-fold reduction in the worker's exposure to pollutants generated in the booth.

LBL has acquired a patent and is discussing collaboration with a private-sector firm in California. The airvest technology still needs some developmental research to improve its ergonomics. Gadgil believes that research may also reduce its costs significantly below the current estimate of about \$200 per unit. Field tests of the improved design must precede full commercialization.

Ashok Gadgil

Spray-booth exposures without the airvest (left); a higher booth velocity and no airvest (center); and the airvest on with the recommended lower booth velocity.

**Hood velocity is measured in feet per minute (FPM). Airvest flow rate is measured in cubic feet per minute (CFM).*

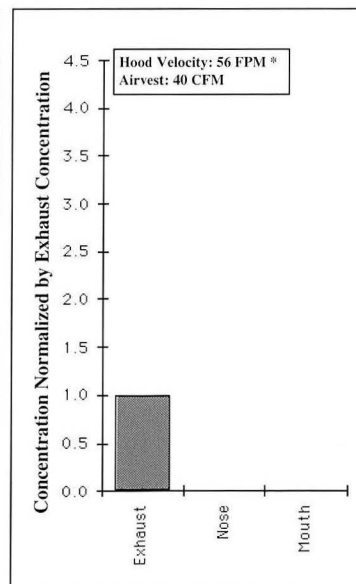
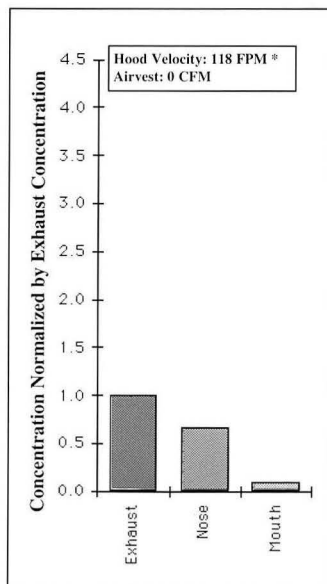
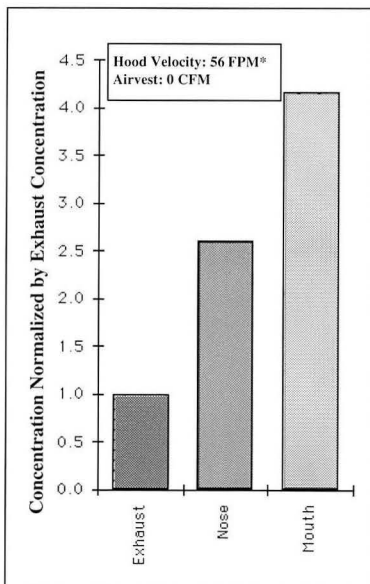

Ashok Gadgil
Indoor Air Quality Controls Project
Indoor Environment Program
(510) 486-4651
Fax: (510) 486-6658

Energy Education

Students and Teachers Come to LBL

Educators are fond of saying that good research and teaching go hand in hand. To live up to the spirit of this truism, LBL, its E&E Division, and the Center have committed efforts to conduct educational outreach in the community. It's federal policy and simply a good thing to do for the Center's neighbors.

Educational programs supported by the Center range from the structured to the unstructured, and from the formal to the still-in-planning. LBL's Center for Science and Engineering Education (CSEE) brings educators to LBL to support their continuing education and send LBL researchers into community schools and institutions to teach the interested about the Center's areas of expertise—science, math, engineering, research, and how to start careers in these fields. One of CSEE's efforts receives funding from DOETRAC, DOE's Teacher Resources Associates program, to bring several high school teachers from across the country to LBL for eight weeks during the summer to continue their own education and to expose them to advanced research. The Center for Building Science and E&E participate in this program through Michael Wilde, a scientist in the Buildings Technology Program and the Center's technology transfer coordinator. Through his efforts, teachers coming to the Center are matched with "mentors" who work with them during their entire visit.

DOE's Teacher Resources Associates Program brings teachers to LBL during the summer to continue their education...

In parallel with this program, the Center is developing its own educational efforts for high school students in the community. In 1991, math teacher Gina Vaughan of Oakland's Skyline High School came to the Center as a part of the DOETRAC program. After spending the summer learning about using hypermedia to teach energy efficiency, Vaughan became interested in CSEE's volunteer program, which brings Lab scientists to local K-12 schools to give talks and demonstrations. At the urging of Center director Art Rosenfeld, a network of Center scientists interested in volunteering their time



Participants in the summer 1993 mentor program (left to right): Neila Kleinsmith (LBL), Mary Charlesworth (California), Deb Hopkins (LBL), Rex Babcock (Kansas), Susanne Flannelly (New Jersey), Allen Letson (California), Michael Wilde (LBL), and Susie Maxwell (Alaska).

began to coalesce into the "Energy Education Network." In March 1993, Vaughan and Wilde drew from the assembled talent to organize a day of activities for nine Skyline students. They toured the infrared camera and aerogel laboratories, received some instruction on energy-efficiency analysis, and held afternoon discussions with ten Center scientists. Vaughan continues to organize "day at LBL" programs for Skyline students.

One more program worth noting is the Center's efforts to establish an educational resource file. Incorporating text, photographs, overhead slides, and curriculum materials published on paper, as well as CD-ROM and other electronic formats, the file will give researchers fast, easy access to materials they can use in classrooms to teach students about energy and the environment.

Future editions of this column will explore other resources available to educators and report on visits and other activities that educators will find helpful. 

i Center for Science and Engineering Education,
 (510) 486-5511 Fax: (510) 486-6660
 Roland Otto, director: (510) 486-5325
 Marva Wilkins, pre-college outreach coordinator:
 (510) 486-5640
 Michael Wilde, Center for Building Science,
 (510) 486-6847, Fax: (510) 486-4089

Technology Transfer

From the Lab to the Marketplace

The life cycle of a product begins with research and development to meet a market need, but it is not complete until findings are disseminated to those who can use them.

The Department of Energy, LBL, and the Center work to bring research and new technologies to the marketplace through tools such as Cooperative Research and Development Agreements (CRADAs), sponsored research, licensing agreements, and information transfer.

Cost-shared Research Projects

CRADAs provide companies and institutions outside of LBL the opportunity to do research cooperatively with scientists at the Lab. Once the parties decide to work together, they

prepare a joint work statement outlining the goals of the proposed research. The Lab and DOE must approve the statement and negotiate a CRADA. Two Center CRADAs currently in negotiation involve electrochromic technology and the Database on Energy Efficiency Programs (DEEP).

...Gas-filled panels have fewer environmental impacts than existing insulating technology...

prepare a joint work statement outlining the goals of the proposed research. The Lab and DOE must approve the statement and negotiate a CRADA. Two Center CRADAs currently in negotiation involve electrochromic technology and the Database on Energy Efficiency Programs (DEEP).

Electrochromic glazings use an applied voltage to control the flow of light through windows dynamically. The window can darken to reduce cooling loads or switch to a transmission state to permit the use of daylight.

DEEP is an effort to gather in one place information about energy-efficiency programs, their operation, participation

Technology Licensing

Some of the technologies developed at the Center are available for licensing and are promoted through the Technology Transfer Department. Patent licenses are flexible and open to negotiation. For example, they can be exclusive licenses in a field of use or nonexclusive. Companies can negotiate a license applicable to one country or a group of countries.

Two recent examples of Center technology licensed to private industry are the thermally efficient compact fluorescent fixtures described on page 4 of this issue, and

insulating gas-filled panels (GFPs). Named best new product in the home technology area by *Popular Science* magazine in 1991, GFPs have fewer environmental impacts than existing technology. They offer performance that's equivalent to or better than CFC-blown foam, the current high-performance insulating material standard. These foams are being phased out as international conventions to protect the ozone layer from further destruction come into force. Developed by Brent Griffith, Dariush Arasteh, and Stephen Selkowitz, the panel is a plastic honeycomb sealed in aluminumized, low-E coated plastic foil containing inert gases that

are good insulators. Manufacturers of prefabricated housing, appliances, and transport systems have expressed interest in licensing GFPs.

Information Programs

The Center's information transfer is manifested as LBL reports, journal papers, and popular articles published by staff scientists; short video presentations; exhibits for trade shows, conferences and museums; and development efforts in multimedia information systems. A recent Center effort in multimedia is an interactive kiosk developed for Southern California Edison's Customer Technology Applications Center that provides energy-efficient building design information. Based on a microcomputer and videodisc player, the system is one of several projects underway in the Building Technologies Program to learn how to use new electronic media to disseminate information more efficiently. Another is the development of an information kiosk for the Department of Energy's Office of Building Technologies.

Center for Building Science Patents : 1992

#5,080,141 1/14/92
Method and Apparatus for Filling Thermal Insulating Systems, Dariush Arasteh

#5,161,884 11/10/92
Thermal Element for Maintaining Minimum Lamp Temperature in Fluorescent Fixtures, Michael Siminovich

#5,174,646 12/29/92
Heat Transfer Assembly for a Fluorescent Lamp and Fixture, Michael Siminovich, Francis M. Rubinstein, Richard E. Whitman

Patent Pending:
Gas Flow Means for Improving Efficiency of Exhaust Hoods, Ashok Gadgil

Patent Pending:
Improved Compact Fluorescent Lamp Using Insulated Septum, Michael Siminovich.

i Cheryl Fragiadakis
LBL Technology Transfer Dept., (510) 486-6467
Fax: (510) 486-6457



Gas-filled panels: An effective new CFC-free insulator for refrigerators and many other applications.

The Cutting Edge

On the Energy Edge

In the Pacific Northwest, 28 commercial buildings have been built to demonstrate cost-effective energy savings with no loss of occupant amenity. Sponsored by the Bonneville Power Administration, the Energy Edge buildings were designed to use 30% less energy than a baseline building built to the Model Conservation Standards, the regional energy code.

The 28 buildings are typical of new commercial construction in the region: office buildings, schools, fast-food establishments, medical clinics, a supermarket, and a convenience store. Floor areas range from 2,000 to more than 1,000,000 square ft² (~200 to 10,000 m²).

A team from LBL's Energy Analysis Program has been assessing the actual energy use in the buildings and comparing it with that of other new buildings in the region as well as with results from computer simulation models. They now have as much as six years of measured energy use for all but one of the buildings and have analyzed "tuned" simulation results (calibrated with monitored data) for 17 of the buildings. The 28 Energy Edge buildings as a group are using more energy than predicted, but they are, for the most part, low-energy users when compared to other new construction in the region. Based on the results from the first five tuned models, the measures are saving 13% less energy than predicted. Lighting measures as a group are saving more than predicted, but heating, ventilation, and air-conditioning and envelope measures are saving less. Based on two years of utility bills, the average energy use for 12 offices is about 13 kWh/ft²-yr (140 kWh/m²-yr), slightly higher than predicted, but well below regional benchmark data. Energy consumption for all 28 buildings, based on the third year of utility bills, is increasing in 60% of the buildings.

Energy Edge buildings were designed to use 30% less energy than a baseline building built to the Model Conservation Standards.

Some of the increase in energy use beyond predictions is attributed to poor commissioning and operations and maintenance (O&M) practices. An example is the building where an increase in



The 13,400 (1,240 m²) square foot Landmark building in Yakima, Washington, one of 28 participating Energy Edge buildings.

heating energy outpaced savings from economizer cooling. The culprit: a damper stuck in the open position. On the energy success side, a pilot commissioning project showed that implementing the time-clock functions of the energy management and control system that regulates the lights reduced annual energy use by about 8%. Occupants can also diminish measure performance, sometimes deliberately—as researcher Mary Ann Piette found. In one building, salespeople were required to be in their sales areas on a fixed schedule, "... occupants rigged fans with paper streamers near their motion sensors to keep the lights on! The fans were controlled with a timeclock set to their work schedules."

The Energy Edge evaluation, which has already provided a wealth of information on the performance of energy-efficiency measures in new commercial buildings, will be completed this year. Bonneville is using project results to provide guidance for commercial program design, to upgrade commercial codes, and to revise conservation supply curves. The data also help identify problems with individual measures to improve future applications and to better define commissioning, control, and O&M procedures to optimize energy savings.

Karen H. Olson



Mary Ann Piette
Building Energy Analysis Group
Energy Analysis Program
(510) 486-6286, Fax: (510) 486-6996

The Cutting Edge

Caltrans Relights its Marysville Office

Researchers in the Building Technologies Program are assessing a lighting retrofit project at the Marysville District Headquarters of the California Department of Transportation.

Also known as Caltrans, the agency has recently completed an installation of deep-cell parabolic luminaires in an open office area that houses design and drafting services for road construction and maintenance in its District 3 headquarters in Marysville. The agency plans to develop specifications for upgrading lighting systems in other offices based on results from assessments of this project.

Rudy Verderber, Francis Rubinstein, Robert Clear, Vincent Berrutto, Werner Osterhaus, and Saba Rofchaei are conducting a detailed analysis of potential improvements in the quantity and quality of illumination in the remodeled space as compared to the original lighting system still intact in other

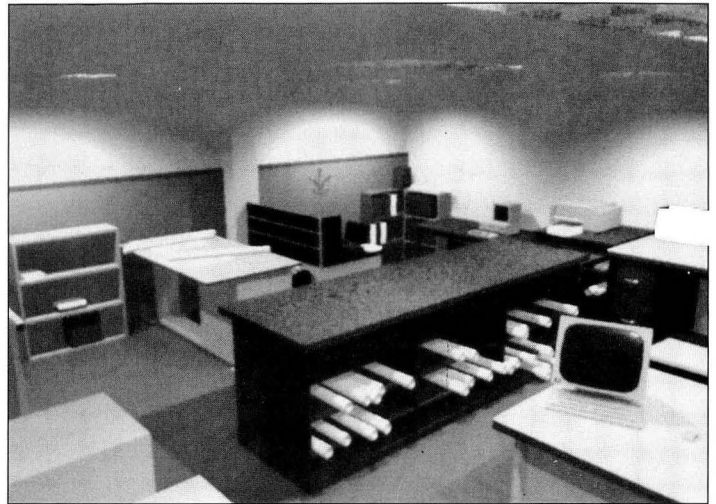

RADIANCE simulations of Caltrans Marysville office before (left) and after retrofit. Note the change in lighting of the walls and elimination of glare from protruding ceiling fixtures.

surements. Marysville was its first real-world application, capturing images of luminance distributions within the field of view of office personnel. The resulting digitized images are now being analyzed at LBL.

Caltrans plans to develop specifications for upgrading lighting systems in other offices based on results from this study.

To develop design schemes that improve lighting quality, team members selected prominent spaces representing the facility's existing and new lighting installations for modeling with LBL's lighting simulation program, RADIANCE. In addition, Caltrans workers were asked to complete survey questionnaires so that the LBL researchers can correlate their photometric measurements and visual assessments with the subjective responses of the building occupants. Interviews with workers provided further information about typical work tasks and their lighting requirements. Based on the findings of this research, LBL will propose guidelines for specifying lighting installations in other Caltrans offices around the state.

Werner Osterhaus

i Werner Osterhaus
 Windows and Daylighting Group
 Building Technologies Program
 (510) 486-4042, Fax: (510) 486-4089

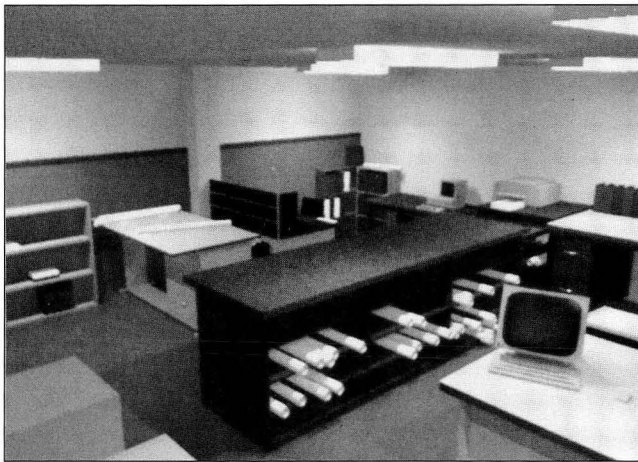

parts of the building. Caltrans project managers and the researchers defined a set of fundamental lighting quality parameters for evaluating the retrofit. During several visits to Marysville, the research team measured illuminance and luminance on task surfaces and more than 100 computer screens in pre- and post-retrofit areas of the building. The analysis procedure also included photographic and video documentation and visual assessments of potential problems, such as glare or contrast reduction on the task surface. A luminance mapper developed by the Lighting Research Group made the luminance mea-

Center Research Facilities

The Environmental Chamber

On the second floor of an unremarkable building at LBL, researchers are using a room within a room to smoke out indoor air pollutants. The environmental chamber is a stainless-steel-lined room of 540 ft³ (20 m³) which can be operated in several ways to meet the needs of different research projects, including studies for which a very low background is required. Scientists of the Indoor Environment Program and their collaborators use the chamber as a controlled indoor environment to study the behavior of a variety of indoor pollutants ranging from cigarette smoke to volatile organic compounds (VOCs) from new carpets.

At the moment, four projects use the facility. Principal investigator Al Hodgson, a chemist with

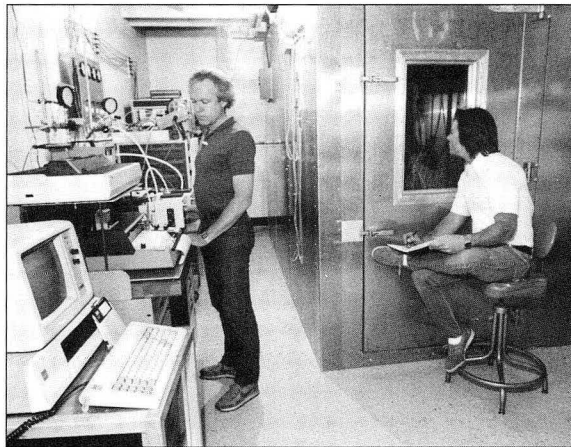

Al Hodgson and Richard Allen test methyl chloride exposures using the environmental chamber.

overall responsibility for the chamber and its operation, is the leader of a team studying the emissions of volatile organic compounds from carpets and carpet pads with funding from the Consumer Products Safety Commission (CPSC). A new carpet or carpet backing material outgasses VOCs at rates that decrease with time and that can be measured accurately in the environmental chamber. Carpeting has been reported to be linked with sensory irritation and other health or comfort problems. The CPSC has been requested by some state agencies to label carpet materials as hazardous.

Joan Daisey and colleagues are studying the emissions of nitrosamines from cigarette smoke and how their concentrations change with time indoors. Nitrosamines, which have been implicated as carcinogens in some studies, are found in many smoked foods and drinks, including bacon and Scotch. Funded by the California Air Resources Board, this research may eventually lead to a better understanding of the relationship between human exposure to environmental tobacco smoke and related health risks, as well as better standards of acceptable exposure. Investigators will use their chamber test results as input to a computer model of human exposure to nitrosamines from cigarette smoke.

Developing a tracer technique to characterize the ventilation rates in office buildings is the object of a study headed by William Fisk and funded by DOE's Office of Building Technologies. A small source of a fluorocarbon-based tracer placed throughout an office building can characterize the emissions of pollutants from common indoor sources like carpets. The environmental chamber offers a convenient tool for testing the tracer's accuracy and measurability.

Finally, in collaboration with Richard White of the University of California's Department of Electrical Engineering and Computer Science, Indoor Environment Program researchers are testing new sensor technology for measuring the indoor concentrations of organic compounds such as toluene and formaldehyde.

Users of the environmental chamber can work with larger assemblages of materials representative of those in homes and offices and scale the samples to test factors like surface-to-volume ratios as experimental parameters, a capability smaller chambers don't have. A growing awareness of the possible risks to human health of indoor emissions sources should keep the environmental chamber a popular instrument for understanding exposure risks for some time to come. 

Allan Chen



Al Hodgson
Indoor Air Chemistry Group
Indoor Environment Program
(510) 486-5301, Fax (510) 486-6658

Hot off the Press

Global Energy Use: Past and Future

A new book from LBL's International Energy Studies group presents a decade's worth of investigation into historic trends in global energy use, describes prospects, and discusses policies for restraining growth in energy consumption.

The authors of *Energy Efficiency and Human Activity* apply an analytical framework that considers three basic factors driving energy use in each sector: activity, structure, and energy intensities. The industrial countries, the developing countries, and the former East Bloc are covered separately.

Much of the book describes how and why energy use has changed in the world since 1973. Energy intensities in manufacturing have declined continuously in the Organization for Economic Cooperation and Development (OECD) countries, contributing to a fall in energy use despite considerable growth in activity. In passenger travel and freight transport, shifts toward more energy-intensive modes such as automobiles, air travel, and trucks have pushed energy use upward. Structural change in the residential sector, especially an increase in appliance ownership, has caused energy use to grow in much of the world. The service sector's fuel intensity for heating has declined greatly in the OECD countries, but electricity intensity has risen.

Turning to the future, the authors supplement their historical analysis with judgments about the possible evolution of key trends. Growth in activity will be especially strong in the developing countries, and structural change is likely to increase energy use considerably as well. The greatest potential for structural change is in the former East Bloc, but the pace of change is very uncertain. Structural change is occurring much more slowly in the OECD countries. With higher energy prices (resulting in part from internalization of environmental externalities) and strong energy-

efficiency policies, intensities in the OECD countries in the year 2010 could be nearly 50% less on average than the level to which trends seem to be pointing. The Soviet scenarios suggest that intensities could decline by almost the full 50% if economic reform is successful and technology levels are upgraded to Western standards. In both cases, however, achieving reductions of this magnitude will require considerable policy effort.

Policies and programs that can help change the course of energy use include reform of energy pricing, efficiency standards, financial incentives,

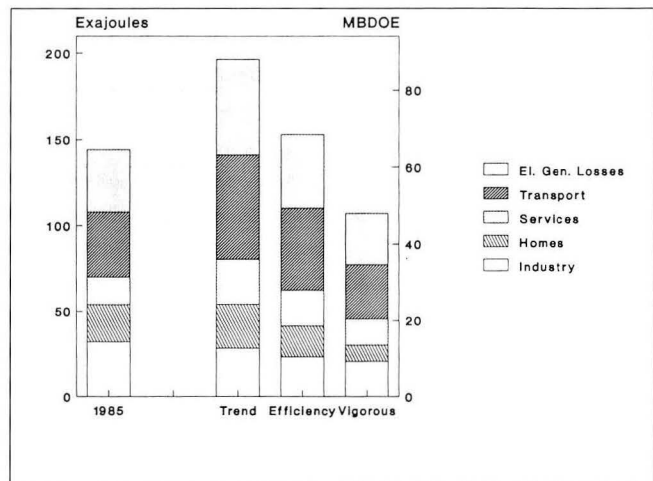

and innovative methods. The authors call for strong action by governments at all levels but stress the importance of considering the full range of factors that will shape realization of the energy-efficiency potential around the world and the need to look beyond energy policy for solutions. Among the conclusions: the emergence of a global market economy with relatively open borders could enhance efforts to improve energy efficiency; and strong policies in the OECD countries to encourage greater energy efficiency would have profound effects worldwide.

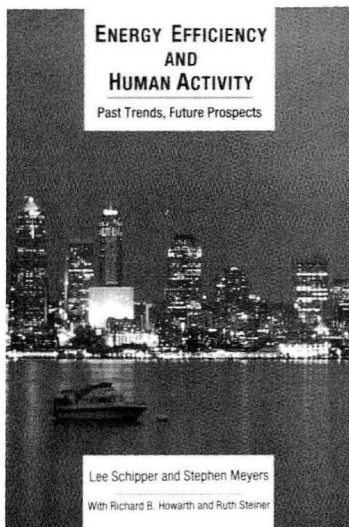

developing countries, and structural change is likely to increase energy use considerably as well. The greatest potential for structural change is in the former East Bloc, but the pace of change is very uncertain. Structural change is occurring much more slowly in the OECD countries. With higher energy prices (resulting in part from internalization of environmental externalities) and strong energy-

Lee Schipper and Stephen Meyers with Richard Howarth and Ruth Steiner. *Energy Efficiency and Human Activity: Past Trends, Future Prospects*. Cambridge, UK: Cambridge University Press. (800) 872-7423; ISBN: 0 521 43297 9

Visitors Far and Wide

The Russian Minister of Ecology and Natural Resources, Victor I. Danilov-Daniljan, spent three days in California as the Center's guest. The Minister presented information on current Soviet energy and environmental dilemmas and participated in a day-long roundtable discussion with representatives of major utilities, manufacturers of energy-efficient technologies, energy regulators, nongovernmental organizations, and Center scientists.

Julian Aizenberg, **one of the former Soviet Union's (FSU) foremost lighting experts**, spent several days at LBL discussing opportuni-

ties for collaboration on energy-efficient lighting. In a special seminar, Aizenberg provided an overview of the Soviet lighting situation, presenting data previously unavailable to the West in the days before Glasnost. During their discussions, the Center's lighting technology experts learned that there has been substantial progress on advanced technologies such as hollow light guides; 45,000 such systems are installed

across the FSU, while very few are installed in North America. For many years, Aizenberg has directed a major lighting research group in Moscow and has edited a leading Russian-language journal on lighting called *Svetotekhnika*. The Center's scientists have had several meetings with representatives of the **Federal Aviation Administration**, including the director of the FAA's Facility System Engineering Service. The main topic of discussion was how to design the airport traffic control tower of the future using advanced building technologies and strategies to achieve an improved indoor environment. Advanced



From left: Minister Danilov-Daniljan, Evan Mills (Assistant Director, Center for Building Science), Victoria Mats (interpreter and Soviet energy analyst), and Len Grossman (PG&E Energy Center) tour the PG&E Energy Center in San Francisco.

ties for collaboration on energy-efficient lighting. In a special seminar, Aizenberg provided an overview of the Soviet lighting situation, presenting data previously unavailable to the West in the days before Glasnost. During their discussions, the Center's lighting technology experts learned that there has been substantial progress on advanced technologies such as hollow light guides; 45,000 such systems are installed

glazings, lighting systems, and indoor environmental controls offer substantial promise for this very specialized type of facility.

Gul Najam Jamy, **Deputy Chief of the National Energy Conservation Center of Pakistan (ENERCON)**, came to LBL seeking information on energy-efficiency R&D in the U.S. and on field experience from DSM programs here. ENERCON's near-term aim is to train auditors, dem-

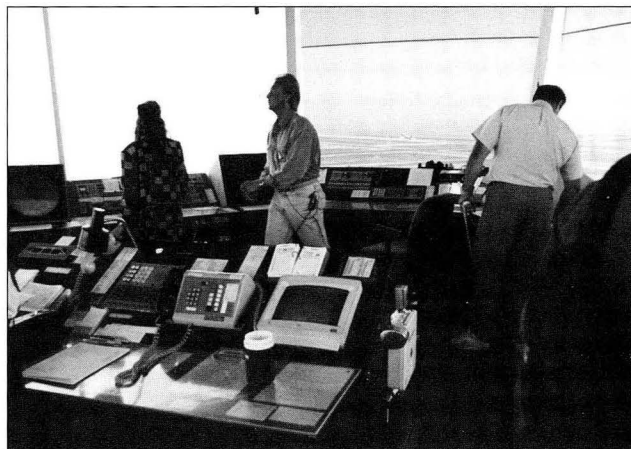

Center researchers toured the San Francisco Airport Traffic Control Tower. Note the harsh contrast created by shaded and unshaded windows, and the upward tilt of the computer monitor to avoid reflections on the screen.

onstrate the commercial viability of efficient lighting technologies and practices, and show that there are new business opportunities for importers, local producers, auditors, and lighting designers. The program's five-year goal is to retrofit about 10% of Pakistan's total commercial building stock (roughly 300-500 buildings).

One of the key topics attracting **ten members of the British Parliament** to LBL was how to integrate energy regulation and market mechanisms to achieve the proper balance of supply- and demand-side investments in the energy sector.

A delegation of six members of **Thailand's Parliamentary Committee on Environment** visited LBL as part of a study tour on alternatives to introducing nuclear power to the electricity supply system in Thailand.

Her Royal Highness, the Princess of Tonga and her Consul General graced the Center with a visit to hear how energy efficiency could help her island nation. Tonga, whose main exports are pumpkins and vanilla, is the only South Pacific nation to have avoided colonization. Representing 16% of all import costs, energy is critical to Tonga's economy and development process. The Princess's main

interest was to learn from the Center how the national utility and other elements of the energy sector could promote increased energy efficiency to reduce the need for costly imported petroleum.

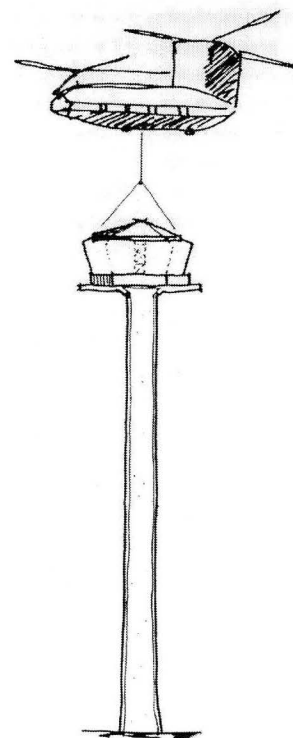

One vision of the Tower of the Future: Modular construction and advanced materials.

Energy Currents

An ADEPT Way to Promote Efficiency

For the first time in more than a decade, the U.S. Department of Energy is involved in a large-scale energy technology assistance effort for developing countries and economies in transition. The new program, ADEPT (Assisting the Deployment of Energy Practices and Technologies), aims to assist

ing the early rounds of proposal selection. Nearly half of the proposals addressed various aspects of improving energy efficiency in developing countries. ADEPT's FY 1994 funding should be commensurate with FY 1993 levels.

Among the eight proposals selected for quick start support, LBL did quite well, re-

The new program, ADEPT (Assisting the Deployment of Energy Practices and Technologies) aims to assist countries in the wise selection of energy technologies as well as building institutional capacity by transferring policy expertise.

countries in the wise selection of energy technologies as well as building institutional capacity by transferring policy expertise. ADEPT will focus its assistance on six program components: needs studies, technology demonstration, technical information, institution building, training, and technical adaptation.

Rick Bradley, the head of the ADEPT program office, sees the new effort as a central element supporting the Department of Energy's technology cooperation mission. In the past, DOE's efforts were focused on the export of technology. The ADEPT program will give DOE the ability to be a "full-service partner in the provision of energy services—both policy transfer and technology—to developing countries," says Bradley.

ADEPT was approved in 1993. The program committed roughly \$1 million of funding for a series of small "quick start" proposals. Bradley said that projects with a potential for near-term results and breadth of lab participation were given added weight dur-

ceiving funding for two projects. In the first, LBL staff will support the establishment of an Energy Efficiency Center in Beijing. The project will be a joint effort of the Energy Analysis Program at LBL, the Global Studies Program at Pacific Northwest Laboratory, and the Energy Research Institute in Beijing. The second project is a demonstration of advanced window technology in buildings in Kuala Lumpur, Malaysia, and Bombay, India. Its intent is to catalyze interest in the development of a market for advanced efficiency technologies in these countries. Mark Levine, group leader of the Energy Analysis Program and principal investigator for the FY 1993 projects, was enthusiastic. He felt "DOE was off to a good start" and had selected "some excellent projects for the first-round funding."

i Nathan Martin, LBL coordinator (510) 486-5137
 Fax: (510) 486-6996
 Department of Energy
 ADEPT office (202) 596-4880
 Fax: (202) 586-3047

Retrofit Legislation at the Urban Level

In March, the city of Berkeley, California, passed new legislation that should serve as a model for local policies intended to keep energy dollars within the community while protecting the environment. The Commercial Energy Conservation Ordinance (CECO) is based on a similar ordinance that has been law since 1989 in San Francisco, Berkeley's neighbor across the Bay. San Francisco is currently the only other city in the world to have this type of legislation. As part of the Berkeley Municipal Code, CECO requires commercial buildings to undergo energy conservation retrofits when they are sold or substantially renovated. CECO was designed with the participation of LBL's Kristin Heinemeier, who also works with the Berkeley Energy Office.

CECO requires only very basic measures designed to bring the most inefficient buildings up to an acceptable standard of energy efficiency, not to raise them to the state of the art. These required measures include duct and pipe insulation, installation of time clocks and other basic controls, cleaning and tuning of HVAC equipment, repair of leaks, and reduction of lighting loads. The ordinance includes a cost ceiling—1% of the building's sale price or 5% of the cost of the renovation—that limits the required expenditure to a reasonable level.

CECO goes into effect on Earth Day (April 22) 1994, and its success will be reviewed after two years.

i Elaine Eisenstadt, City of Berkeley Energy Office, (510) 644-6309

Center Becomes Co-Sponsor of the ECEEE Summer Study

The Center was a co-sponsor of the first Summer Study of ECEEE (the European Council for an Energy-Efficient Economy). ECEEE is the European sister organization of the American Council for an Energy-Efficient Economy. This year's gathering took place in Runstensgården, just north of Copenhagen, Denmark. Denmark's Minister of Energy opened the conference, which was attended by about 150 people representing 22 countries. Paper presenters and co-authors from LBL included Jim McMahon, Joe Eto, Chuck Goldman, Barbara Atkinson, and Evan Mills.

i Jan Moen, Norwegian Energy Administration, Postboks 5091 Mag. 0301 Oslo, Norway
 +47 2 95 91 42
 Fax: +47 2 95 90 99
 or
 Hans Nilsson
 Swedish National Board for Industrial and Technical Development
 117 86 Stockholm, Sweden
 +46 8 681 91 00
 Fax: +46 8 681 9585

ECEE³

Awards and Citations

Researchers at the Center and its associated programs have received numerous awards for their contributions to the field of energy efficiency. Some recent examples:

Federal Laboratory Consortium Special Award for Excellence in Technology Transfer - 1993

Steve Selkowitz and Dariush Arasteh

Award for the development and transfer to the U.S. building industry of the technology base for "superwindows"—windows designed with better thermal performance than insulating walls.

PEW Charitable Trust Award - 1991

Ashok Gadgil

Award of \$150,000 over three years for work related to promoting energy efficiency in developing countries.

Popular Science Magazine's Best of What's New Award - 1991

Dariush Arasteh, Stephen Selkowitz, and Brent Griffith

Grand award in home technology category for development of gas-filled insulating panels.

PUB-731 Fall 1993-7000

This work was supported by the U.S. Department of Energy under Contract No. DE-AC03-76SF00098
Energy & Environment Division
Lawrence Berkeley Laboratory
University of California
Berkeley, CA 94720
An Equal Opportunity Employer

This document was prepared as an account of work sponsored by the United States Government. Neither the United States Government nor any agency thereof, nor The Regents of the University of California, nor any of their employees, makes any warranty, express or implied, or assumes any legal liability or responsibility for the accuracy, completeness, or usefulness of any information, apparatus, product, or process disclosed, or represents that its use would not infringe on privately owned rights. Reference therein to any specific commercial product, process, or service by its trade name, trademark, manufacturer, or otherwise, does not necessarily constitute or imply its endorsement, recommendation, or favoring by the United States Government or any agency thereof, or The Regents of the University of California. The views and opinions of authors expressed herein do not necessarily state or reflect those of the United States Government or any agency thereof or The Regents of the University of California and shall not be used for advertising or product endorsement purposes.

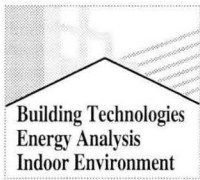

Center *for* building science News

Lawrence Berkeley Laboratory
Mailstop 90-3058
University of California
Berkeley, California 94720
USA

Non-Profit First Class

U.S. Postage

PAID

Berkeley, CA

Permit No. 1123

