

# Lawrence Berkeley National Laboratory

## Recent Work

### Title

The U5.0 Undulator for the ALS

### Permalink

<https://escholarship.org/uc/item/41k971sm>

### Authors

Hoyer, E.  
Chin, J.  
Halbach, K.  
et al.

### Publication Date

1991-05-01



# Lawrence Berkeley Laboratory

UNIVERSITY OF CALIFORNIA

## Accelerator & Fusion Research Division

Presented at the IEEE Particle Accelerator Conference,  
San Francisco, CA, May 6-9, 1991, and to be  
published in the Proceedings

### The U5.0 Undulator for the ALS

E. Hoyer, J. Chin, K. Halbach, W.V. Hassenzahl,  
D. Humphries, B. Kincaid, H. Lancaster,  
and D. Plate

May 1991

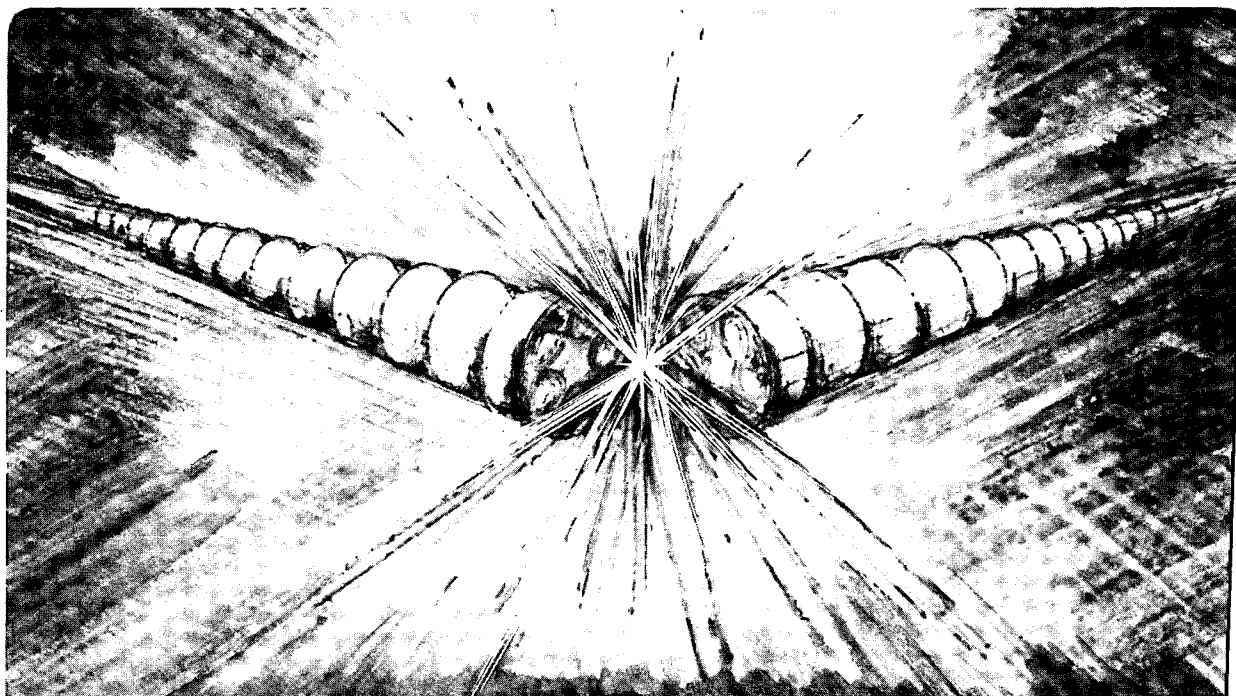

Prepared for the U.S. Department of Energy under Contract Number DE-AC03-76SF00098

LOAN COPY  
Circulates  
for 4 weeks  
Bldg. 50 Library.  
LBL-29908  
Copy 2

## **DISCLAIMER**

This document was prepared as an account of work sponsored by the United States Government. While this document is believed to contain correct information, neither the United States Government nor any agency thereof, nor the Regents of the University of California, nor any of their employees, makes any warranty, express or implied, or assumes any legal responsibility for the accuracy, completeness, or usefulness of any information, apparatus, product, or process disclosed, or represents that its use would not infringe privately owned rights. Reference herein to any specific commercial product, process, or service by its trade name, trademark, manufacturer, or otherwise, does not necessarily constitute or imply its endorsement, recommendation, or favoring by the United States Government or any agency thereof, or the Regents of the University of California. The views and opinions of authors expressed herein do not necessarily state or reflect those of the United States Government or any agency thereof or the Regents of the University of California.

## THE U5.0 UNDULATOR FOR THE ALS\*

E. Hoyer, J. Chin, K. Halbach, W.V. Hassenzahl, D. Humphries, B. Kincaid  
H. Lancaster, and D. Plate

Accelerator and Fusion Research Division  
Lawrence Berkeley Laboratory  
University of California  
Berkeley, CA 94720

May 1991

Paper presented to the IEEE Particle Accelerator Conference, San Francisco, CA, May 6-9, 1991

\*This work was supported by the Director, Office of Energy Research, Office of Basic Energy Sciences, Materials Sciences Division of the U.S. Department of Energy, under Contract No. DE-AC03-76SF00098

# THE U5.0 UNDULATOR FOR THE ALS\*

E. Hoyer, J. Chin, K. Halbach, W. V. Hassenzahl, D. Humphries, B. Kincaid,  
H. Lancaster, D. Plate

Lawrence Berkeley Laboratory, University of California  
Berkeley, California 94720

## Abstract

The U5.0 Undulator, an 89 period, 5 cm period length, 4.6 m long insertion device has been designed and is in fabrication. This undulator will be the first high brightness source, in the 50 to 1,500 eV range, for the Advanced Light Source (ALS) and is scheduled for completion in 1992. A modular hybrid configuration utilizing Nd-Fe-B permanent magnet material and vanadium permendur is used that achieves 0.837 Tesla effective peak field. Correction of the vertical field integral is with permanent magnet rotors at the ends. Gap adjustment is with an arrangement of roller screws, chain drives, a gear reduction unit and a stepper motor driven by a closed loop control system. The vacuum chamber design is a two-piece, machined and welded 5083-H321 aluminum construction of 5.1 m length. Magnetic design, subsystem design and fabrication progress are presented.

## I. INTRODUCTION

The Advanced Light Source (ALS), a third generation synchrotron radiation source, is currently under construction at the Lawrence Berkeley Laboratory.<sup>1</sup> This facility consists of a 50 MeV linac, a 1 Hz, 1.5 GeV booster synchrotron and a low-emittance electron storage ring optimized for the use of insertion devices at 1.5 GeV. The use of insertion devices in the storage ring will produce high brightness beams in the UV to soft X-ray range.

The U5.0 Undulator will be the first high brightness source in the 50 to 1,500 eV range. It is scheduled for completion in 1992. To achieve high brightness, the U5.0 undulator design must meet the stringent requirements derived from the need for rapid scanning of narrow spectral features and the need to avoid perturbing the electron beam in the storage ring.<sup>2</sup>

The engineering parameters, shown in Table I for the U5.0 Undulator, are derived from operating constraints and spectral and storage-ring requirements. Figure 1 shows an end view of the U5.0 Undulator with most major subsystems identified.

## II. MAGNETIC STRUCTURE

The magnetic structure provides the required magnetic fields and includes the periodic magnetic structure, end magnetic structures, backing beams and if required auxiliary tuning coils.

The ALS insertion devices incorporate hybrid magnetic configurations consisting of Nd-Fe-B magnetic blocks and vanadium permendur poles. The hybrid design was chosen because there are several advantages over the pure current sheet equivalent material (CSEM) design.<sup>3</sup>

Table I. U5.0 Undulator engineering design parameters

Parameter	Value
Maximum peak field (@ 1.4 cm magnetic gap)	0.89 T
Effective peak field (@ 1.4 cm magnetic gap)	0.837 T
Period length	5 cm
Number of periods	89
Number of full field poles	179
Nominal entrance sequence	0,-1/2,+1,-1
Overall length	455.8 cm
Pole width	8 cm
Pole height	6 cm
Pole thickness	0.8 cm
Number of blocks per half-period (one side of pole)	6
End correction range ( $B_y$ )	1,500 G cm
End correction range ( $B_x$ )	None
Steering coils (short)	~ 25 cm
Dipole trim coils (long)	4.5 m
Steering and trim field strength	$\pm 5$ G
Systematic gap variation	58 $\mu$ m

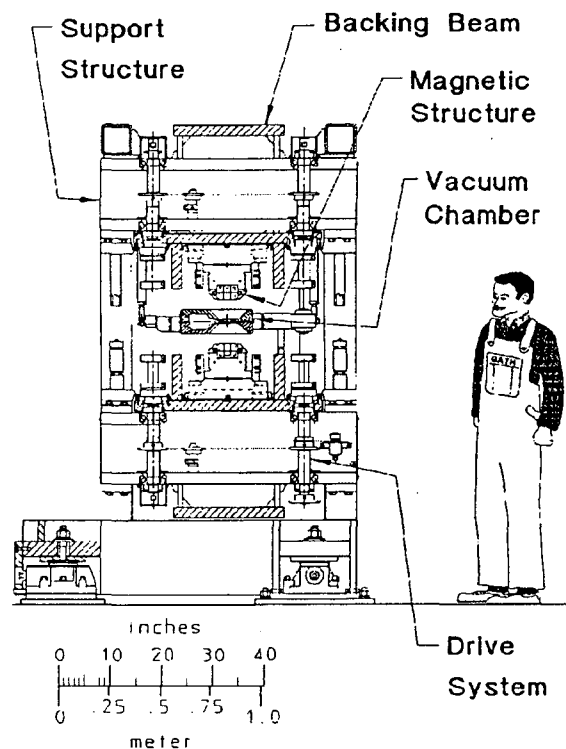

Fig. 1. U5.0 Undulator Design.

For undulators, the objective of the magnetic design is to develop a magnetically well behaved structure which yields a high value of  $B_{eff}$  for mid-plane fields.  $B_{eff}$  is given by

$$B_{eff}^2 = \sum_{i=0}^{\infty} \left( \frac{B_{2i+1}}{2i+1} \right)^2 \quad (1)$$

where  $B_1$  is the amplitude of the fundamental,  $B_3$  is the amplitude of the third harmonic, etc.

The magnetic configuration is based on 2-D modeling with the computer code PANDIRA and a 3-D Hybrid theory for hybrid CSEM insertion devices.<sup>4,5</sup> To verify the magnetic design for U5.0, a model was built and tested under a variety of conditions.<sup>6</sup> The undulator performance criteria are met by tolerances based on the hybrid CSEM insertion device theory. The tolerances established for U5.0 are given in Table II.<sup>7</sup>

Figure 2 shows the U5.0 magnetic structure, which is made of: a) half-period pole assemblies, that include an aluminum keeper, a vanadium permendur pole pinned into the keeper and six Nd-Fe-B blocks (3.5 cm square by 1.7 cm thick in the magnetization direction) bonded into the assembly<sup>8</sup> (this design allows for accurate vertical and longitudinal pole tip placement); b) assembly sections that consist of an aluminum pole mount onto which 35 half-period pole assemblies are mounted and accurately positioned; c) stress relieved steel backing beams that are 4.5 m long, 81 cm deep, and 89 cm wide<sup>9</sup> (each beam provides magnetic shielding and holds five assembly sections and two end sections); and d) dipole and steering coils, if needed.

Table II. U5.0 Magnetic Structure tolerances

Error Type	Total Tolerance	Error (%)
Spacing CSEM to pole	102 $\mu$ m	0.08
Pole thickness	50 $\mu$ m	0.03
Vertical pole motion (gap)	22 $\mu$ m	0.05
Pole width	100 $\mu$ m	0.03
Surface easy axis orientation	$\pm 2.3$ degrees	<u>0.16</u>
Total:		<u>0.19</u>

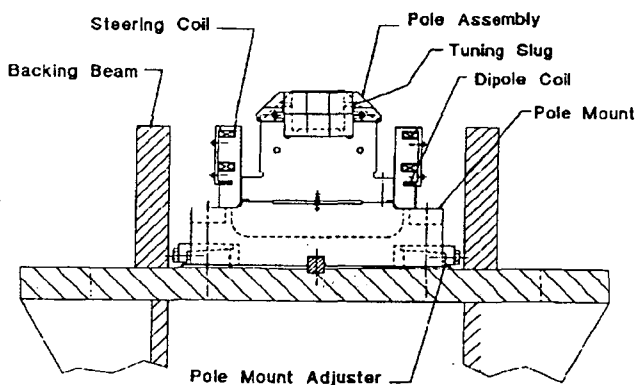

Fig. 2. U5.0 magnetic structure assembly section

The upper and lower backing beams are tied together with low reluctance Ni-Fe linkages to reduce the effect of environmental fields on the electron beam trajectory.<sup>10</sup>

To avoid steering the beam as it travels through the insertion device, it is necessary to control the configuration of the fields at the ends. Figure 3 shows the end magnetic structure that utilizes a system of Nd-Fe-B rotors to fine-tune the fields at the ends of the insertion device. There are four rotors at each end, and a fixed quantity of Nd-Fe-B at each rotor location. In the absence of significant gap-dependent field errors in the periodic structure, a single set of orientations for the rotors should minimize steering over the entire range of gaps.

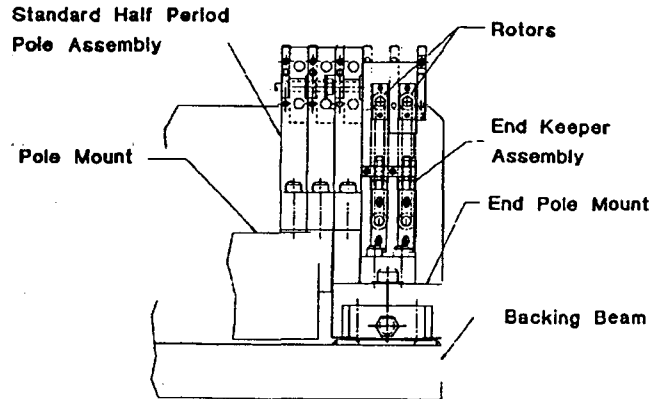

Fig. 3. End pole assembly.

### III. SUPPORT AND DRIVE SYSTEMS

The support and drive systems include the support structure that provides the framework for holding the magnetic structure and the drive system that opens and closes the magnetic gap. Requirements for the support structure include: supporting a maximum magnetic load of 84,000 lb; maintaining a magnetic gap variation of 58  $\mu$ m at the smallest gap (14 mm); meeting the ALS storage ring, tunnel and adjacent beamlines space requirements; accommodating the vacuum system and its support structure; and, being capable of installation, alignment and servicing in the storage ring.

The support structure is of rigid construction consisting of a base onto which two lower horizontal members are mounted. Four vertical posts are in turn attached to the lower horizontal members and the two upper horizontal members are attached to the tops of these posts. The four horizontal beams pass thru the webs of the backing beams to limit the overall height of the support structure to less than the 8 ft tunnel height.

A magnetic-load compensating spring system is provided to counteract the gap-dependent magnetic load.<sup>11</sup> Each of the eight spring assemblies consist of two helical compression springs connected in series to match the gap dependent magnetic load to within 20%.

The drive system requirements are set by the spectral requirements and include: the capability of opening the magnetic gap with an 84,000 lb magnetic load; a step resolution of 1  $\mu$ m; a maximum scanning speed of 2.3 mm/s; a magnetic gap range of 1.4 cm to 21.6 cm; an opening or closing time of five minutes or less and determination of gap position by an absolute encoder.

Changing the magnet gap in an insertion device requires moving the backing beams. This is accomplished by rotating the 2 mm pitch Transrol roller screws that are mounted to the horizontal beams and support the backing beams. Specifically, the four right-handed roller screws attach to the upper backing beam and the four left-handed roller screws attach to the lower backing beam. They are connected by a shaft coupling and combine to provide equal and opposite vertical motion when rotated. Gap motion is provided by the rotation of a stepper motor which is transmitted through a gear box and a series of sprocket wheels and roller chains to the roller screws. An absolute rotary encoder is coupled to one of the Transrol roller screw shafts to read the absolute position of the magnet gap.

Undulator temperature control is important. A vertical temperature gradient of greater than 0.1 degree C in the undulator backing beams produces excessive spectral broadening. The U5.0 Undulator will have an enclosure, and the temperature in the enclosure will be maintained by circulating the air.

#### IV. CONTROL SYSTEM

The insertion device control systems are designed to provide sufficient position accuracy, resolution, velocity and range information for the motors and encoders for all anticipated insertion devices. In addition, the control system must control and monitor the dipole and steering correction power supplies, as well as controlling gap dependent rotator positioning, if required. The insertion device control systems are to be integrated into the overall accelerator computer control system.

A Compumotor system has been selected for the gap control and is currently undergoing tests.

#### V. VACUUM SYSTEM

The objective of the vacuum system is to provide a  $10^{-9}$  Torr vacuum at the insertion device beam aperture. Figure 4 shows a plan view of an undulator vacuum system. Two vacuum chambers are required for ALS operation, one for commissioning and one for dedicated operation.<sup>12</sup> The commissioning chamber has an elliptical beam aperture of dimensions 1.8 cm vertical x 6.2 cm horizontal. The chamber for dedicated operation has a rectangular beam aperture of dimensions 1.0 cm vertical x 6.2 cm horizontal.

The 5.1 m long undulator vacuum chambers will be made of two pieces of machined 5083-H321 aluminum alloy. Both chambers have a total horizontal aperture of 21.8 cm, the inner 6.2 cm provides the circulating beam aperture and the outer aperture allows the bending-magnet synchrotron radiation to pass through the chamber. The radiation is then absorbed by the photon stop located at the exit end of the chamber. External surfaces of the chambers have pockets machined into them for the magnet poles. The shape allows a minimum magnetic gap of 2.2 cm for commissioning and 1.4 cm for dedicated operation.

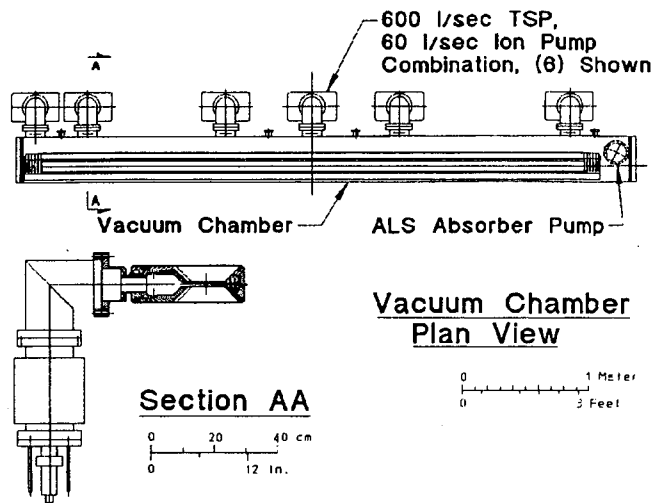

Fig. 4. Undulator vacuum system layout.

The vacuum system consists of six combination 600 l/s titanium sublimation and 60 l/s ion pumps (which give a net pumping speed of 173 l/s each at the antechamber) and an ALS absorber pump of 1450 l/s capacity giving a total antechamber pumping speed of 2500 l/s.

#### VI. ACKNOWLEDGMENT

\*This work was supported by the Director, Office of Energy Research, Office of Basic Energy Sciences, Materials Sciences Division of the U.S. Department of Energy, under Contract No. DE-AC03-76SF00098

#### VII. REFERENCES

1. "1-2 GeV Synchrotron Radiation Source," LBL PUB-5172, Rev. (July 1986)
2. "U5.0 Undulator Conceptual Design Report," LBL PUB-5256 (November 1989).
3. W.V. Hassenzahl, et al., "Insertion Devices for the ALS at LBL," IEEE Particle Accelerator Conference, 89CH2669-0, Page 1222 (March 1989).
4. K. Halbach, et al., developed PANDIRA, an improved version of POISSON which allows solution of permanent magnet and residual field problems; POISSON is an improved version of TRIM [A. Winslow, J. Computer Phys. 1, 149 (1967)].
5. K. Halbach, "Insertion device Design: 16 Lectures Presented from October 1988 to March 1989," LBL Publication V 8811-1.1-16.
6. W.V. Hassenzahl, E. Hoyer, and R. Savoy, "Design and Test of a Model Pole for the ALS Undulator," to be published at this conference, LBL-29921 (May 1991).
7. R. Savoy, et al., Calculation of Magnetic Error Fields in Hybrid Insertion Devices, LBL-27811.
8. E. Hoyer, "Magnetized Neodymium-Iron-Boron Blocks," LBL Specification 734D (April 1989).
9. E. Hoyer, "Backing Beam Design Calculations," LBL Engineering Note M6834 (May 1989).
10. E. Hoyer, "Flexible Yoke Design," LBL Engineering Note M7039B (July 1990).
11. J. Chin, "Magnetic Load Compensating Springs," LBL Engineering Note M6829 (April 1989).
12. E. Hoyer, "Vacuum Chamber Design," LBL Engineering Note M6806 (February 1989).

LAWRENCE BERKELEY LABORATORY  
UNIVERSITY OF CALIFORNIA  
INFORMATION RESOURCES DEPARTMENT  
BERKELEY, CALIFORNIA 94720