

**DhoLuo
vowel
harmony**

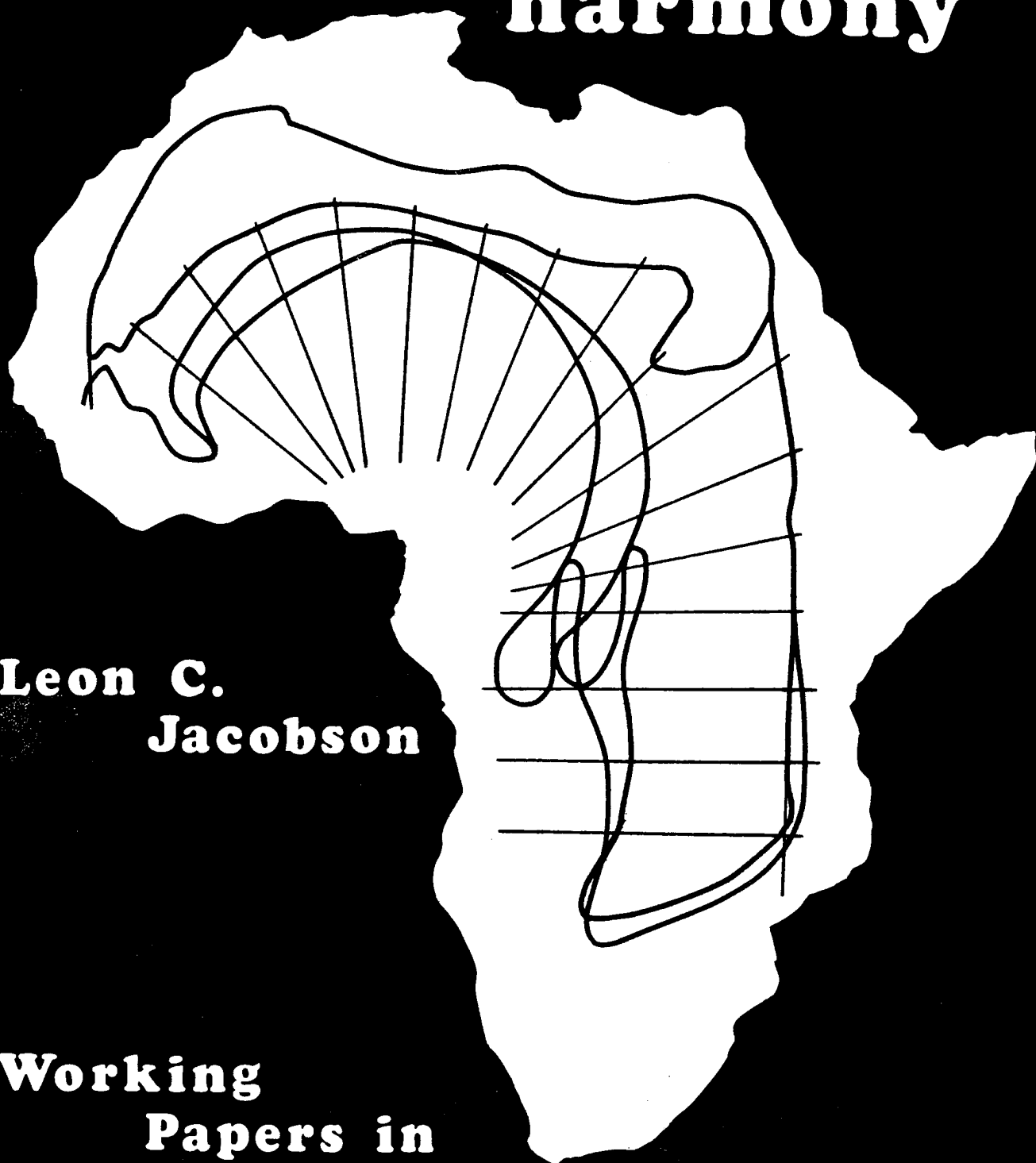

**Leon C.
Jacobson**

**Working
Papers in
Phonetics No. 43
UCLA Nov. 1978**

DhoLuo vowel harmony: a phonetic investigation

Leon Carl Jacobson

Working Papers in Phonetics, 43

November 1978

University of California, Los Angeles

This work is dedicated to my extended family, who, while they never expected me to devote my life to cattle and crops, could never quite fathom my interest in tongues and tribes, and especially to my mother and father, neither of whom ever tethered me and both of whom probably wonder whether I would have followed a more conventional path if they had.

Table of Contents

	List of tables	iv
	List of figures	v
	Preface and acknowledgements	vi
	Vita	viii
	Abstract	ix
Chapter one.	Introduction	1
Chapter two.	The data base	8
Chapter three.	Tongue height and pharynx width	30
Chapter four.	Measurements and analysis	38
Chapter five.	Number of factors	47
Chapter six.	Interpretation of factors	59
Chapter seven.	Comparisons and implications	78
Appendix I.	Technical specifications	83
Appendix II.	Measurement values (raw data)	84
Appendix III.	Deviation values (processed data)	88
Appendix IV.	Representative solutions (analyzed data)	92
Bibliography	References cited	119

List of Tables

Table 1.	Tongue height values	30
Table 2.	Pharynx width values	31
Table 3.	Difference in mean square error	57
Table 4.	Difference in correlation squared	57
Table 5.	Factor Loadings: Four-factor aberrant solution	61
Table 6.	Factor loadings: A converged four-factor solution	62
Table 7.	Factor loadings: A different converged four-factor solution	63
Table 8.	Factor loadings: A converged three-factor solution	67

List of figures

0.	Map showing location of the Western Nilotic languages	
1.	Vowel harmony categories in Southern Lwo	3
2.	Histograms of vowel height	4
3.	DhoLuo vowel variability	5
4.	The X-ray machine	8
5.	Positioning of subject for X-raying	10
6.	Area of exposure	11
7-14.	Tracings of the vocal tract	14-29
15a-h.	Pharynx width tracings for front vowels	32-33
16a-h.	Pharynx width tracings for back vowels	34-35
17.	Relationship of tongue height to pharynx width	37
18.	Vocal tract cross sections	38
19.	Construction of vocal tract measurement grid	41-42
20.	Radial measurement grid	44
21.	Goodness of fit curve: 6 subjects, 16 sections	50
22.	Goodness of fit curve: 4 subjects, 16 sections	52
23.	Goodness of fit curve: 6 subjects, 12 sections	54
24.	Goodness of fit curve: 4 subjects, 12 sections	55
25.	Goodness of fit curve: the four analyses compared	56
26.	Analogical representation: 4 factors, 6 speakers, 16 sections	64
27.	Vowel loading graphs: 4 factors, 6 speakers, 16 sections	66
28.	Analogical representation: 3 factors, 6 speakers, 16 sections	68
29.	Vowel loading graphs: 3 factors, 6 speakers, 16 sections	69
30.	Analogical representation: 2 factors, 6 speakers, 16 sections	70
31.	Vowel loading graph: 2 factors, 6 speakers, 16 sections	71
32.	Analogical representation: 3 factors, 4 speakers, 16 sections	72
33.	Vowel loading graph: 3 factors, 4 speakers, 16 sections	73
34.	Analogical representation: 2 factors, 4 speakers, 16 sections	74
35.	Vowel loading graph: 2 factors, 4 speakers, 16 sections	74
36.	Ontogeny of the solutions	76

Preface and acknowledgements

This investigation began as a continuation and outgrowth of joint research done with Mona Lindau and Peter Ladefoged in 1972 on the physiology of vowel production in Twi, Igbo, Ateso, and DhoLuo and of a seminar paper for Peter Ladefoged on the acoustic characteristics of DhoLuo vowels. At that time it became clear that there was a considerable overlap of vowel qualities as traditionally measured acoustically using the first two formant frequencies. I wanted to determine instrumentally the physiological characteristics of DhoLuo vowels as a start in sorting out the vowel system, especially with respect to the phonological distinction made in DhoLuo for vowel harmony as reported by Tucker [Tucker and Bryan 1966].

The execution of this study has gone through several stages: outlining of the problem, collection of the data, analysis of the data, and interpretation, writing and rewriting of the findings. It has involved more work and expense than originally envisioned and consequently more time, especially since long periods of time passed between (and during) stages while further means were sought. The travel, living and research expenses for this work were borne entirely by me and my wits except for the costs of publication and a summer's support as a research assistant. For this I am grateful to Peter Ladefoged, director of the UCLA Phonetics Laboratory, who, along with Mona Lindau, has provided moral and critical support since the inception of this investigation. I am also grateful to Peter for his fostering of a cooperative spirit and "hands-on" attitude within the Phonetics Laboratory which enabled me to have free access to all of the equipment (most importantly for me the PDP-12 computer), to be provided with space to work in, and to have interesting and interested colleagues with whom to discuss my work. I especially appreciate the interaction with my past and present colleagues Cathe Browman, Ron Carlson, Sandra Ferrari Disner, Jackson T. Gandour, Louis Goldstein, Stephen Greenberg, Richard Harshman, Jean-Marie Hombert, Mona Lindau, Ian Maddieson, Willie Martin, John Ohala, George Papçun, D. Lloyd Rice, Dale Terbeek, and Eric Zee.

The collection of the data would not have been possible without my association with the Department of Linguistics and African Languages at the University of Nairobi, the support provided by its head, M. A. Abdulaziz, and the cooperation and assistance of the following students who volunteered to participate in this study: W. K. Alwala Ochieng, J. O. P. Andelle, James Hannington Anditi, Raphael O. Ogweno, Jerome Okelo, Jared J. O. Okungu, Caleb Othieno Opondo, and Ezekiel A. Okoth Wamanya. Nor would this study have been possible without the technical assistance and advice generously provided by B. Mburu, D. S. R. (R), and L. R. Whittaker, O. B. E., F. F. R., of the Kenyatta University Hospital, whose facilities were used for taking the

X-rays. I am thankful to all of these individuals for their contributions to this study.

I extend particular thanks to my friends who contributed to this study indirectly, but equally importantly, by putting me up and putting up with me when means were tight and times were tough. Of special note are Thomas and Claudia Hinnebusch, Pamela Pinto, Dollie Meyers, Chori Orozco, Martin Mould, Nancy Cohen, Harriet Wolf, and Joy Chuck. For ever-sustaining me with yet another cup of excellent coffee I credit Alora Burton, Martin Mould, and Joy Chuck; for tea and bhajias I say shukria to Primla Sofat; and the nary-coffee-nor-tea award is earned by my latter day amiga Kay Blackburn (Walker). Thanks to Glenn and Janice Meyer and Jack and Mary Jane Gandour for touting me after the flag was up and for keeping my jollies up in the stretch. For endurance beyond the call of duty in the face of bad pennistilence, I extend my gratitude to Anna Meyer, Ma Anand Vimal, and Renée Wellin, the able UCLA linguistics secretariat. From the start of this work to its finish Jack and Vicki Fromkin and Peter and Jenny Ladefoged have been personally supportive, often when no other support was forthcoming. I suspect that I have not been properly expressive of my gratitude for their concern and faith and do not want them to misinterpret this as lack of appreciation on my part. I am indeed grateful to them and hope that the completion of this dissertation shows that their faith was not misplaced. Thanks, guys.

I appreciate the encouragement of my committee members Paul Schachter, Michael Lofchie, and Christopher Ehret and the encouragement and patience of the cochairmen, Victoria Fromkin and William E. Welmers, who allowed me all the rope I needed.

Finally, I'd like to acknowledge May Cheney for doing the drawings of the X-ray machine and positioning of the subjects (figures 4-6). The cover, map, figures, and typescript are all my own doing. Any errors or oversights in the presentation of this work are my own responsibility.

VITA

Personal data

Born in Thief River Falls, Minnesota, 16 November 1942

University education

United States Naval Academy (Annapolis) 1960-61

University of Minnesota (Minneapolis) 1961-63

University of California (Los Angeles) 1963-66, 1969-73

Academic qualifications

B.A. (Anthropology) 1965 University of California, Los Angeles

M.A. (Linguistics) 1975 University of California, Los Angeles

C.Phil. (Linguistics) 1973 University of California, Los Angeles

Academic employment

Temporary lecturer, Department of Linguistics and African Languages
University of Nairobi, Nairobi, Kenya. 1973-74

Assistant Lecturer, Department of Linguistics and Nigerian Lan-
guages, University of Ibadan (Jos Campus), Jos, Nigeria. 1975-76

Lecturer, Department of Languages and Linguistics, University of
Maiduguri, Maiduguri, Nigeria. 1977-present

Publications

"The feature Advanced Tongue Root," with Mona Lindau and Peter
Ladefoged. *Working Papers in Phonetics* 22:76-95. (1971)

"Wm. E. Welmers: A biographical sketch and list of publications."
Supplement 6, *Studies in African Linguistics*, pp. vii-xv. (1976)

Papers in African Linguistics in Honor of Wm. E. Welmers, edited
with Larry M. Hyman and Russell G. Schuh. Supplement 6, *Studies
in African Linguistics*. (1976)

"Phonetic aspects of DhoLuo vowels." *Papers from the Eighth Con-
ference on African Linguistics*, edited by Martin Mould and Thomas
J. Hinnebusch, pp. 127-35. Supplement 7, *Studies in African Lin-
guistics*. (1977)

ABSTRACT OF THE DISSERTATION

DhoLuo vowel harmony: a phonetic investigation

by

Leon Carl Jacobson

Doctor of Philosophy in Linguistics

University of California, Los Angeles, 1979

Professor Victoria A. Fromkin, Cochairman

Professor Wm. E. Welmers, Cochairman

A salient characteristic of the sound systems of the Nilotic languages of East Africa is a vowel harmony system in which, simply put, a vowel belongs to one of two phonologically complementary categories. The exact nature of the distinguishing phonetic correlates of these categories has not been clearly defined, but the categories have been impressionistically labeled as "tense", "close", and "breathy" for one category and "lax", "open", and "creaky" for the other. Using the DhoLuo language of southwestern Kenya, this study attempts to ascertain and define the phonetic correlates of these categories.

Toward this end, tracings of vocal tracts were made from X-ray negatives taken during the production of eight DhoLuo vowels by eight speakers. A significant difference between the two harmony categories was shown to exist using the simple measures of height of the tongue and width of the pharynx, whereby vowels of the first category have a higher tongue position and a wider pharynx relative to their counterpart vowels in the second category.

A trimodal factor analysis procedure, known as PARAFAC, was applied to the description of vocal tract shapes for these vowels using a specially designed reference grid. The vocal tract shapes were quantified by measuring the distance between articulatory surfaces along 18 lines belonging to this grid. Analyses were first made for six speakers and then for four speakers (after two had been selected out for divergent behavior). A comparison of analyses for the entire vocal tract against the vocal tract without the lower pharynx showed that any pharyngeal contributions also affect the entire vocal tract. The PARAFAC analysis for the six speakers shows that the data for the vocal tract can be attributed to four factors, while that for four speakers indicates three factors. There appear to be three factors in common between these two analyses: 1) a front/back parameter that decisively separates all front vowels from all back vowels, 2) a tongue root parameter that maintains a distinction between vowels of different harmony categories, and 3) a height parameter that distinguishes vowel height as well as vowel harmony membership. In the four-factor solution the extra factor appears to be another height component whose presence is required to account for individual variability introduced by the two additional speakers. The correlations achieved in these analyses between the actual data and the modeled data are greater than 0.93 for the analyses of the entire vocal tract and 0.96 for those analyses which excluded the lower pharynx. Solutions with a greater number of factors than those mentioned do not make substantive contributions to these correlation values nor are their factors all interpretable in phonological terms.

The results of this study contrast with those of a factor analysis for English vowels [Harshman, Ladefoged, and Goldstein 1977] where only two factors were required to describe tongue shapes. That English is not a vowel harmony language would contribute to this difference, as well as the small numbers of speakers involved in the studies and the different measurement techniques used.

This study of an East African vowel harmony language also contrasts with the radiographic investigation of West African vowel harmony languages, where a uniform mechanism for distinguishing vowel harmony categories has been found. In DhoLuo several mechanisms are variously used. No conclusions can be made about this difference because of the small numbers of speakers involved in all of the studies.

Because of the different phonetic means to achieve the same phonological distinction, it is suggested that a phonological cover term be used for the vowel harmony distinction.

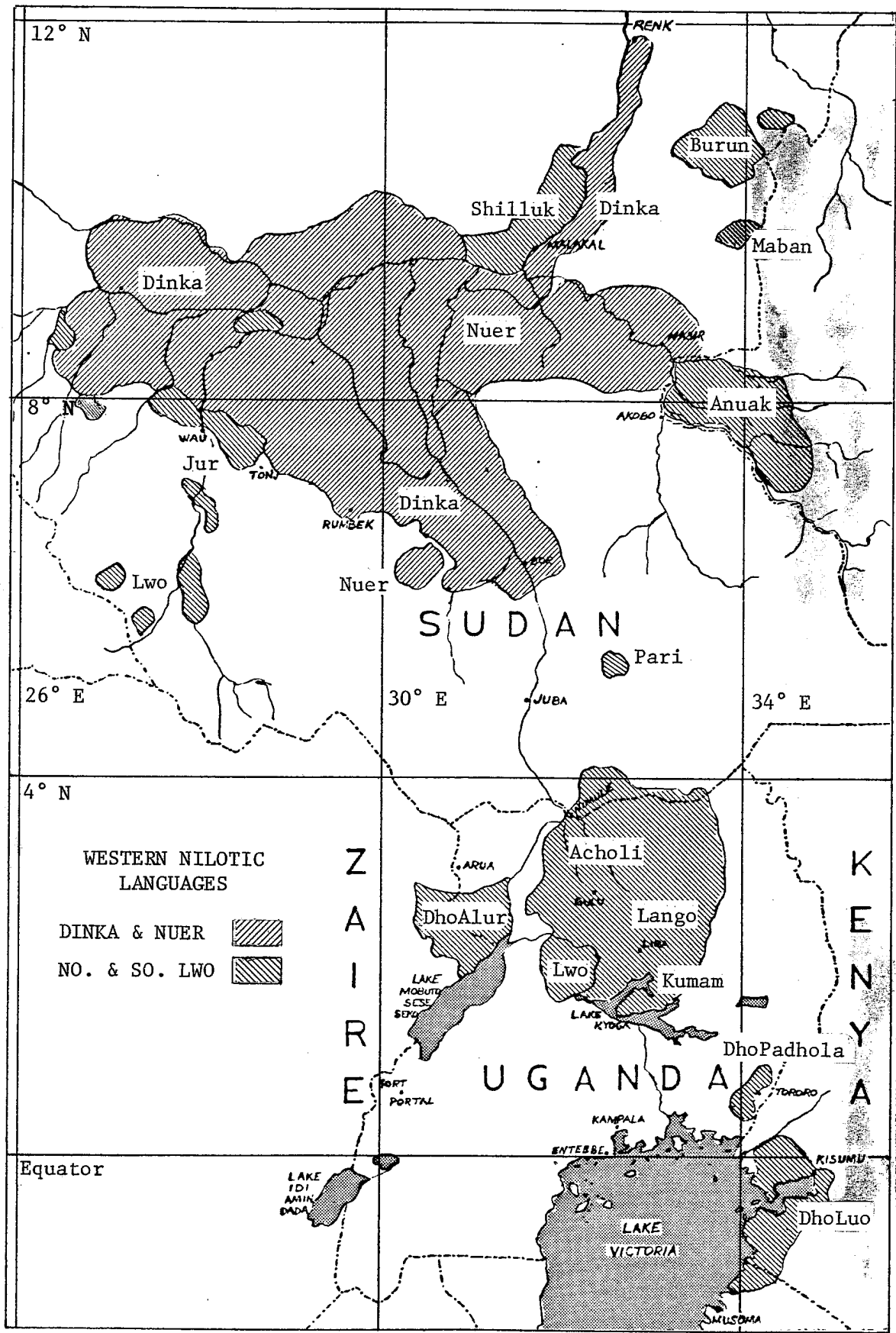

Jacobson, based on Tucker and Bryan 1966.

Chapter one: Introduction

DhoLuo is spoken by the people of the Luo tribe. These people, who call themselves JoLuo, live principally in southwestern Kenya, but also extend in small numbers along the eastern shore of Lake Victoria into northern Tanzania. The JoLuo first arrived at their present location about 500 years ago in the first of a series of migrations into Kenya from the north. These migrations were part of a larger dispersion of Nilotic peoples over many centuries from which groups split off and settled along the way [Ogot 1967].

The languages with which DhoLuo is closely related (Alur of Uganda and Zaire; Acholi, Dhopadhola, Dhopaluo, Kumam, Labwor, Lango, and Nyakwai of Uganda; Anuak, Jur, and Shilluk of the Sudan) form a complex of dialects or languages which have certainly descended from the same ancestral language. Just how close the relationship is among them has not yet been determined, but many of the "languages" that we refer to by different names may indeed be largely mutually intelligible and are better thought of as dialects of a common language rather than as distinct languages. In a glottochronological study of five of these languages (DhoLuo, Alur, Acholi, Lango, and Shilluk), Blount and Curley [1970] date the divergence from the protolanguage to be from 900 to 1300 years ago.

As these migrating groups diverged from each other, they came into contact with speakers of alien languages which influenced their own. DhoLuo, for example, has borrowed heavily from the LuLuyia dialects that it has been in contact with. To a lesser degree, vocabulary items have entered DhoLuo from KiSwahili and English. The languages of the migrating groups also underwent internal change quite independently of each other. As a result of this, there are many obvious differences within this dialect or language complex; yet the overall unity is undeniable.

The names *Lwo* and *Luo* have been used to refer to several languages within this complex, which itself has been called *Lwo* and *Lwoo*. In order to avoid confusion I shall consistently use the term *DhoLuo* when referring to the language of the JoLuo, which is their preference as well, even though the language has been commonly cited as *Luo* in much of the published literature.

This complex of languages along with Burun, Dinka, and Nuer of the Sudan (which themselves may form a coordinate complex) together comprise the Western Nilotic subbranch of Nilotic, which in turn is a branch of the Eastern Sudanic division of the Chari-Nile subfamily of the Nilo-Saharan language family as based on Greenberg's African language classification [Greenberg 1963a]. The geographic extent of the Western Nilotic languages is essentially the environs of the White Nile River and its tributaries from Renk in the north to Lake Kyoga in the south (12° north latitude to 2° north latitude) and just to the northeast and east of Lake Victoria. See the map on the facing page for an approximate location of these languages.

The vowel systems of these languages include nine or ten different vowel qualities. It has been claimed that the vowels belong to two phonological categories and that these categories are distinguished from each other by voice quality, although the exact nature of this voice quality difference has not been clearly defined [Crazzolara 1933, Huntingford 1959, Nebel 1948, Stafford 1967, Tucker 1936, 1975, Tucker and Bryan 1966, Welmers 1973]. The two categories have been variously described using the following subjective and impressionistic terms: "hard" vs. "hollow", "open" vs. "close", "tense" vs. "lax", "muffled" vs. "brassy", and "breathy" vs. "creaky". The hollow, close, tense, muffled, or breathy vowels all refer to one phonological category, while the hard, open, lax, brassy, or creaky vowels constitute the other.

To exemplify this, the following examples are taken from Tucker [1971:633] for the DhoLuo language (the final [o] or [ɔ] is a suffix):

Category A (hollow, close, tense, etc.)		Category B (hard, open, lax, etc.)	
wiro	'to annoint'	wiro	'to turn back'
gueyo	'to bark at'	gweyo	'to kick'
koro	'to abuse'	korɔ	'to pursue'
buko	'to smear'	bokɔ	'to provoke'

In these languages it is almost always the case that in any word all the vowels are from only one of these categories. A small number of affixes which are immune to this restriction form the only exceptions. This phonological phenomenon, known as vowel harmony, is relatively uncommon in the languages of the world, with only three language families having it as a common occurrence. These are the Ural-Altai language family in Eurasia (e.g., Finnish and Hungarian for Uralic and Turkish and Mongolian for Altaic) and the Niger-Kordofanian and Nilo-Saharan language families in Africa. The vowel harmony which occurs in Ural-Altai is primarily based on agreement in the front/back dimension, but also, in some languages, on degree of lip rounding. The type of vowel harmony found in the African languages has one vowel category either higher than the other in terms of vowel height (either the complete category is higher than the other or the vowels of one category are respectively higher than the corresponding vowels of the other category; see Lindau, Jakobson, and Ladefoged [1972] for analyses of Twi, Igbo, Ateso, and DhoLuo, which display these different types) or the categories differ in terms of voice quality, as mentioned in the preceding paragraph, or both. This characteristically African type of vowel harmony has been referred to as relative height harmony [Greenberg 1963b], category harmony [Tucker and Bryan 1966], and cross-height harmony [Stewart 1971].

To return to the vowel system of Western Nilotic, Tucker [Tucker and Bryan 1966: 402] states: "An outstanding characteristic of these languages is the presence of both 'hard' and 'breathy' (or 'hollow') Voice Quality in the pronunciation of vowels, diphthongs, and semi-vowels." In the footnote to this comment, Tucker defines breathy as "pronounced with open pharynx, accompanied by a voiced aspiration" and says that "non-breathy vowels are pronounced with varying degrees of pharyngeal constriction."

For the group of Western Nilotic languages that includes DhoLuo, Tucker adds for the breathy vowels that, "the aspiration is less evident, but the voice quality is 'hollow'." He presents a diagram of the vowels for this group of languages, which he calls Southern Lwo. Accompanying this diagram, which is reproduced below as figure 1, is his statement that, "In S. LWO there is a simple dichotomy of five 'hard' vowels against five 'hollow' vowels, in which the Categories are distinguished by both tongue position and voice quality."

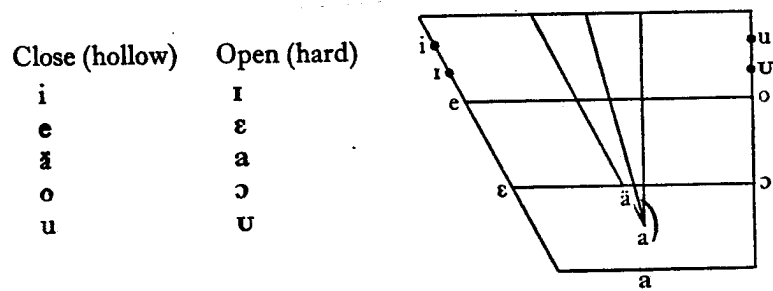

Figure 1. Vowel harmony categories in Southern Lwo [after Tucker and Bryan 1966:404].

The analysis by Welmers [1973] differs, in that Welmers recognizes only nine vowels, eliminating the *ä* of the first group. Welmers says [p. 37], "As stem vowels which determine the harmonic group of affix vowels, these fall into two groups: /i, e, u, o/ and /ɪ, ɛ, ɔ, ɔ, a/. In the affixes whose vowels are determined, however, /a/ is neutral; it may accompany vowels of the first as well as the second group." Welmers does not ascribe the hollow and hard qualities to his two harmony groups and says further that "a phonetic distinction for which such terms might be appropriate ... is by no means obvious in Dho-Luo" [p. 38].

The DhoLuo orthography does not acknowledge the vowel harmony category difference, having five orthographic symbols to represent nine phonological vowels [Tucker 1971]:

Orthography	a	e	i	o	u				
Phonology	a	e	ɛ	i	ɪ	o	ɔ	u	ʊ

Consequently, the examples presented on the preceding page would have both members of a pair spelled the same way even though they contrast phonologically: *wiro*, *gueyo*, *koro*, and *buko*.

The published descriptions of the vowel harmony categories mentioned above are all based on the intuitive phonetic characterization of the investigator. None of the studies attempted to find the articulatory or acoustic features which differentiate the two categories. Instrumental means are required for this.

It seemed plausible that an acoustic analysis of the vowels would reveal what acoustic parameters distinguished the two categories. I therefore decided (at an early stage in my investigation) to look at the vowel height values for the pair of vowels represented by each orthographic symbol.

In this study, an adult native speaker of DhoLuo read 187 bisyllabic verbs in context. The text was in orthographic transcription. If vowel height (as usually defined in acoustic terms) is used to distinguish the vowels in each pair, then a plot of the vowel height values for each orthographic vowel should be bimodal since each orthographic symbol *i*, *e*, *o*, *u* represents two phonological vowels. It was hypothesized at the beginning of this pilot study that a distribution that is not bimodal would indicate that if there is vowel harmony -- and there is general agreement among linguists that this is the case at least phonologically -- then it must be based on something other than vowel height.

The native speaker was then asked to listen to each item on the tape, repeat it aloud, and identify the vowels. This he was able to do without any difficulty or hesitation. The values of the first and second formant frequencies of the stem vowels (the vowel of the first syllable in the verb) were then determined from wide-band spectrograms. The first formant frequency was taken as an index of vowel height [Ladefoged 1976] and histograms were made for each group of vowels represented by the four orthographic symbols *i*, *e*, *o*, and *u*. The stem vowels so plotted were 143 in number and are displayed in the histograms of figure 2, with the phonologically "hollow, close, tense" vowels represented by circles above the F_1 frequency values (in Hz) and the "hard, open, lax" vowels represented by exes below these values.

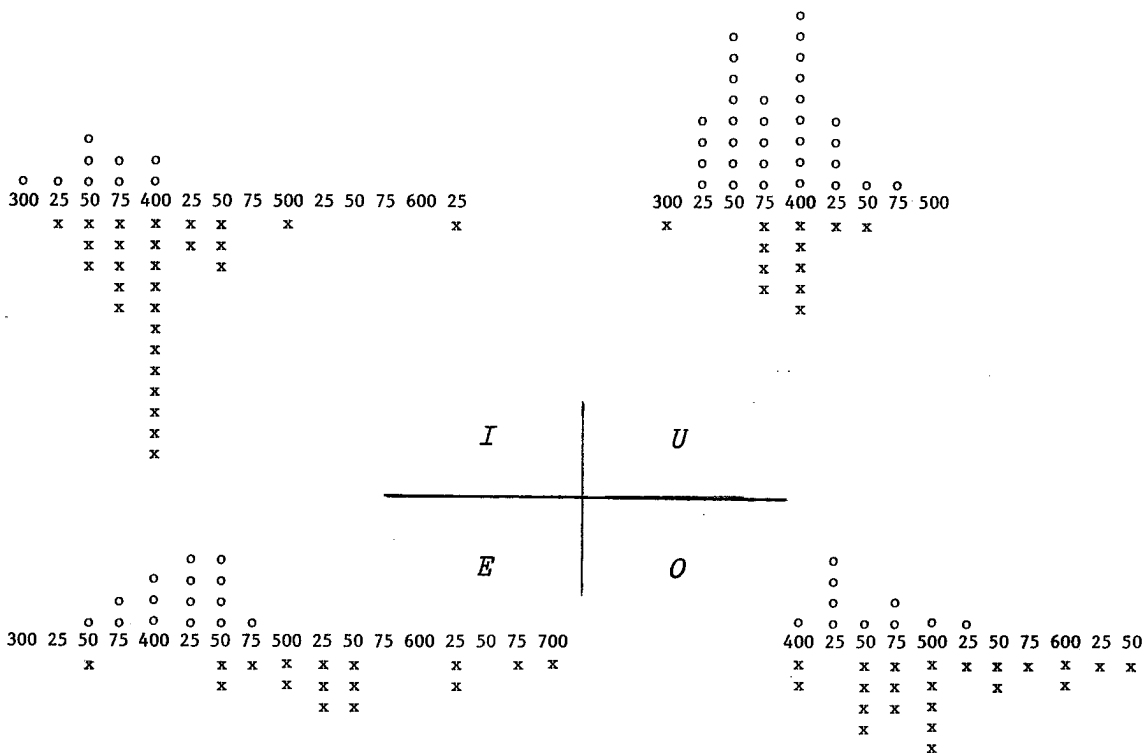

Figure 2. Histograms of vowel height (as F_1 values in Hz).

As can be seen in figure 2, the distribution on these histograms does not support vowel harmony based on the F_1 definition of vowel height. Only in the case of orthographic *e* (the *e/ε* contrast) was there a clear bimodality in the distribution of F_1 ; for *i* and *u* there was no evidence of bimodality; for *o* the possibility of bimodality was marginal.

F_1 versus F_2 was then plotted for the phonological vowels. This revealed a similar picture, with a clear separation between /*e*/ and /*ε*/ but with an overlapping of the other contrast pairs. This is summarized in figure 3, where each ellipse represents one standard deviation from the mean for the F_1 and the F_2-F_1 values -- or, assuming an ideal distribution, 68% of the area of distribution for the respective vowels. In an attempt to reduce noise in the data set (as from adjacent consonants, for example), I extracted from the corpus two near-minimal sets and did a similar F_1 versus F_2-F_1 plot for them [Jacobson 1977]. This showed the front vowels being more discretely separated than in the larger, noisier, set -- yet back vowels were still too close together in terms of F_1 to be considered to be distinct in this respect.

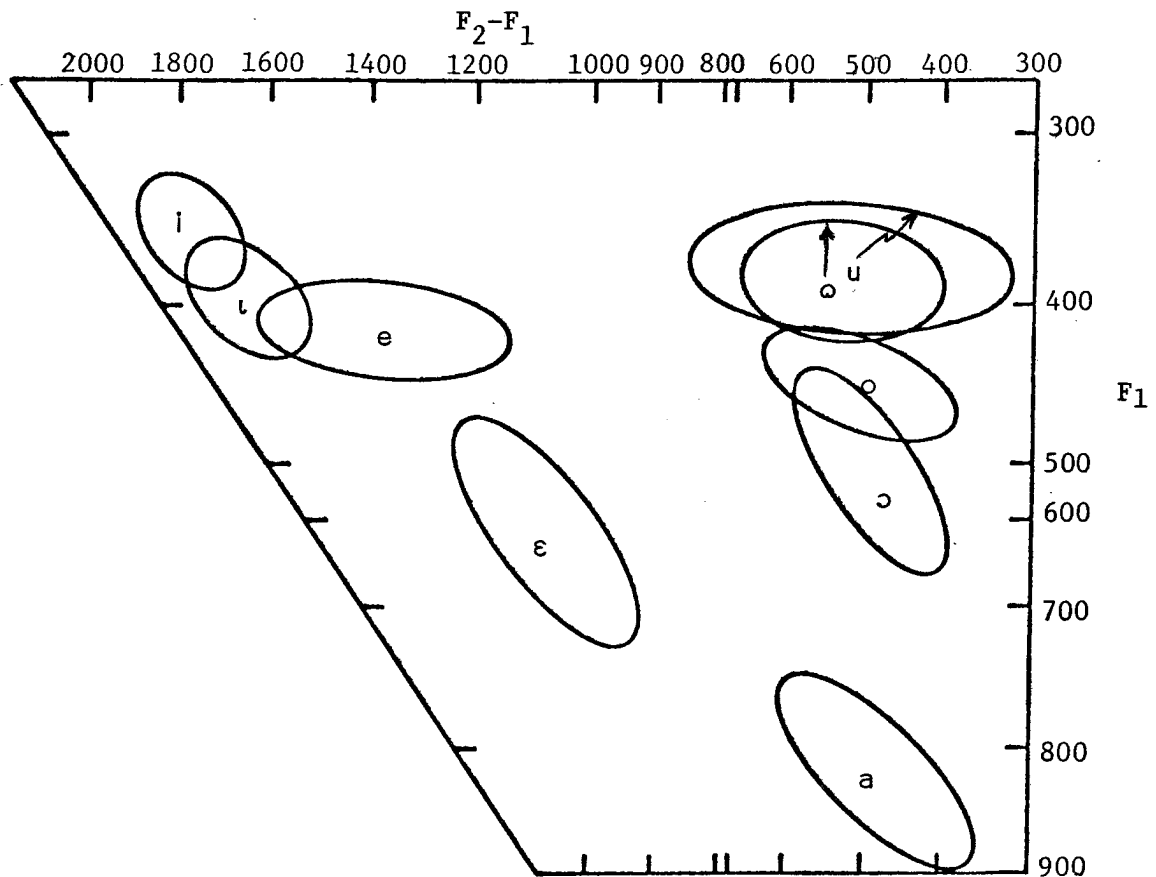

Figure 3. DhoLuo vowel variability (formant frequency values in Hz).

This acoustic analysis clearly shows that acoustic information provided by F_1 and F_2 is not sufficient for distinguishing the vowel harmony categories that scholars claim for DhoLuo. It should be repeated that the native speaker with whom I worked had no difficulty in separating the words into two sets based on harmony category.

It is clear then that further investigation was needed. If the constraint on vowel sequences within a word is a real one, then there must be something in the speech signal which is used to distinguish the categories and which can be extracted by children learning the language. There is a difference in vowel production that is recognized by native speakers and acknowledged by linguists who have studied the language -- especially by Tucker, who attributed it to a physiological opposition between an open and a constricted pharynx [Tucker 1936, forthcoming, Tucker and Bryan 1966]. This is an empirical claim which, until now, had never been instrumentally verified.

Given the fact that the "traditional" type of acoustic analysis did not reveal what it is in the speech signal that separates these vowel categories it seemed that an articulatory study was required. This study would be based on the hypothesis that Tucker's impressions were correct: In DhoLuo there is an articulatory difference in the configuration of the pharynx that results in a systematic auditory distinction between sets of vowels which phonologically belong to exclusive vowel harmony categories, even though the acoustic correlates of this difference cannot be discerned using traditional measures.

This investigation then is aimed at discovering what articulatory "features" distinguish the vowel harmony categories in DhoLuo. The method used for doing this was to gather and analyze articulatory data from X-rays taken of the vocal tract during vowel production. Chapter 2 reviews the procedure used to collect these data by radiography. It also presents the data as vocal tract tracings from the X-rays.

In chapter 3, simple measurements are taken of the highest point of the tongue and the widest point of the pharynx. The measurements for contrasting vowels are compared and the significance of their differences is determined by a paired t test.

Using the same articulatory information -- the shapes of the vocal tract during production of eight DhoLuo vowels by eight speakers -- we now quantify it at a number of points throughout the vocal tract using a bifocal coordinate system of my own design. The construction of this measurement grid is described in detail. The remainder of chapter four consists of a brief introduction to PARAFAC, the multimodal factor analysis program which is used to analyze the quantified data.

Chapters five and six present the results of this factor analysis, seeking to determine the correct number of factors to account for the data and interpreting these factors in a physiological or articulatory manner.

The final chapter, number seven, discusses some questions raised earlier in the work, summarizes the conclusions reached, and mentions their implications for linguistic and phonetic theory. A review and comparison is made of other work treating the same topic. Directions for future research leading out of this investigation are suggested.

Four appendices are attached. The first appendix provides an outline of technical specifications. The second one gives the measurements of the vocal tract and the formant frequency values used in this investigation. In the third appendix these data are rendered as deviation values from a mean, which is how they are fed into the PARAFAC analysis program. The last appendix shows the factor loadings for representative solutions of the factor analysis -- the PARAFAC output -- both in tabular form and as analogical representations.

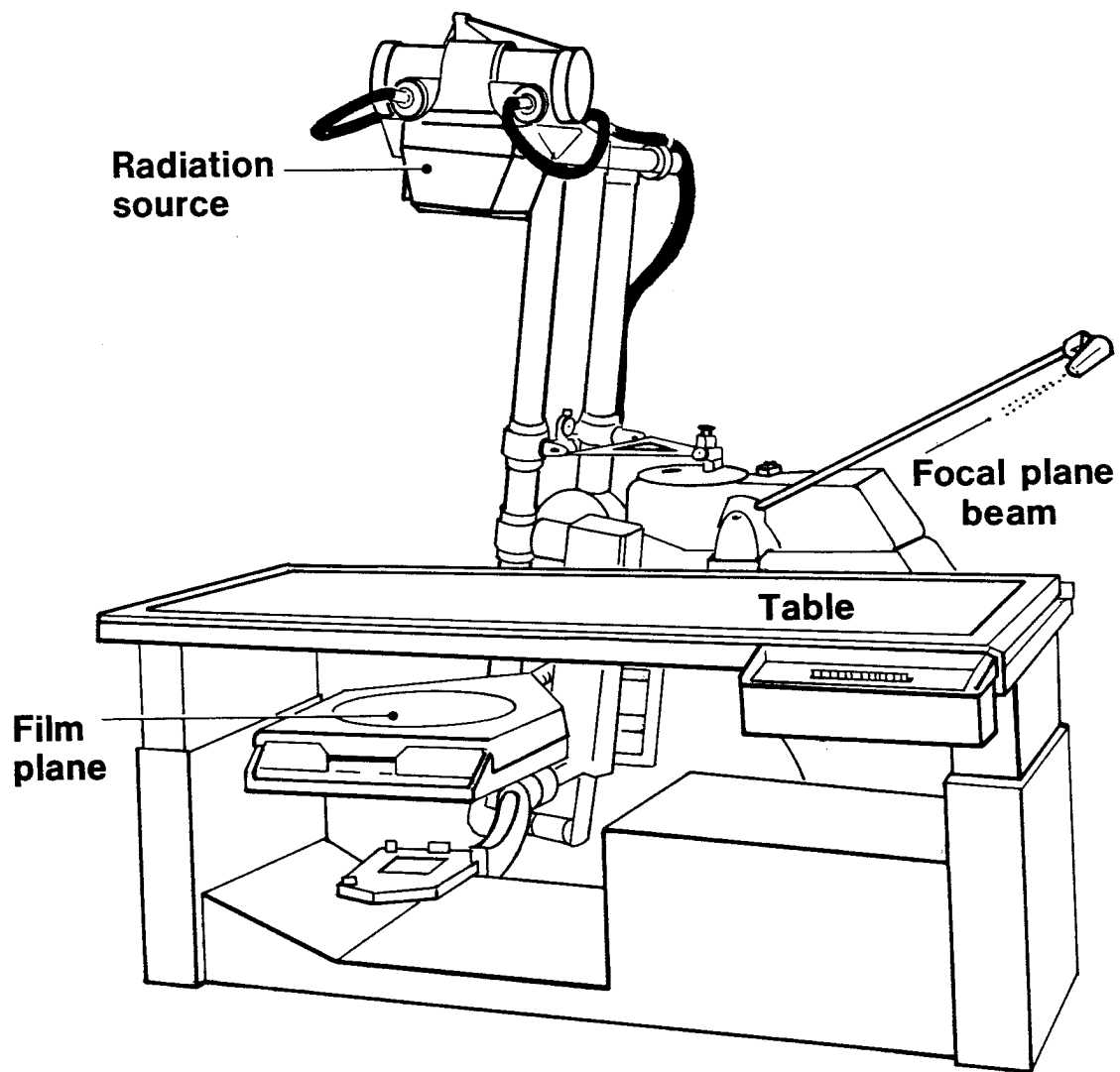

Figure 4. The X-ray machine.

Chapter two: The data base

BACKGROUND AND EQUIPMENT

The use of X rays is the only method for determining the complete shape of the vocal tract during speech production. An earlier study using radiography and concerned with the characterization of vowel harmony [Lindau, Jacobson, and Ladefoged 1972] was based for DhoLuo on (cine)radiographic data from only one speaker. For the present study I considered radiographic data from eight speakers; this provided a more reliable data base. This chapter will discuss the procedure for obtaining these data. The X-ray tracings are presented at the end of the chapter.

The eight speakers used in this investigation were all first or second year linguistics students at the University of Nairobi. These students were all native speakers of DhoLuo and had taken a phonetics course that included practice in the production of varied speech sounds. Before the X-raying session, each student participated in a training session where the procedure was thoroughly rehearsed.

High-quality audio tape recordings were made of each subject saying each word followed by the first syllable of the word said in such a manner that the vowel was sustained in a steady state for several seconds. Subjects rehearsed this procedure until they could perform without difficulty or discomfort. The purpose of doing this was to give the subjects practice in sustaining a steady-state vowel, since this would be required during the X-raying.

The same set of minimal pairs as in the 1972 study was used in case it would be desirable to make comparisons between the separate studies at a later date. In some cases the glosses differ from those of the previous study, but the phonetic shapes are identical. These pairs are:

<i>piyo</i>	[pijo]	'to land'	<i>piyo</i>	[pɪjɔ]	'fast, quick'
<i>le</i>	[le]	'animal'	<i>le</i>	[lɛ]	'axe'
<i>bodho</i>	[bodo]	'to lisp'	<i>bodho</i>	[bɔdɔ]	'prostitute'
<i>chudo</i>	[tʃudo]	'payment'	<i>chudo</i>	[tʃɔdɔ]	'to pucker'

Since /a/ has no harmony counterpart, it was not included in this study (cf. chapter 1; see Tucker, [forthcoming]).

The X-ray negatives (radiograms) from which the data for this investigation were taken were made using a high-precision tomographic X-ray machine. This machine, pictured in figure 4 (facing page), focuses on a narrow plane so that only the midsagittal area is clearly visible in our negatives, with the teeth and mandible blurred out of view. This is achieved by having the X-ray tube (radiation source) and the film holder, which are attached to a freely-swinging parallelogram, move in an arc in a fixed mutual relationship about one point so that they always remain parallel to each other. Through the point of rotation the plane of focus is parallel to the filmplane and depicted sharply, while above and below it everything is intentionally blurred, leaving no recognizable or pre-

cise trace. The table on which the subject lies is not connected to this swinging parallelogram and can be moved up or down in relation to the fixed point of rotation (i.e., the plane of focus); because of this the enlargement factor is constant. The use of this machine did impose on us the restriction that the subjects had to lie on their sides during exposure. This made it difficult to standardize positioning and it was not possible under the circumstances to manufacture a suitable head brace to keep a given subject from moving his head. Consequently there is some positional deviation from exposure to exposure, though the following procedure was designed to minimize such movement.

Each subject lay on a shallow, troughlike table on his left side with his head supported by a bolster. This table could be adjusted vertically or horizontally in any direction, but always remained parallel to the floor and did not change its orientation. One silver coin of known dimensions was taped to the back of the subject's neck at the base of the skull while an identical coin was taped on the chin, both on the midline. Silver is opaque to radiation and the image of the coin on the negative can show the amount of deviation, if any, there is from a true midsagittal section, as well as the degree of magnification. The table the subject lay on was adjusted vertically so that a beam that indicates the plane of focus shone down the center line. I judged this center line to pass across the diameter of the coin on the subject's chin and through a small strip of adhesive tape (app. 1cm by 2.5cm) that had been placed longitudinally along the midline of the subject's forehead for this purpose. The single most difficult task was trying to ensure that the subject's head was in alignment. To ease this positioning task a mirror mounted on a small tripod was placed next to the subject near the edge of the table so that he could directly monitor the alignment of his own head. Figure 5 provides a visualization of this setup. Besides the planar beam that

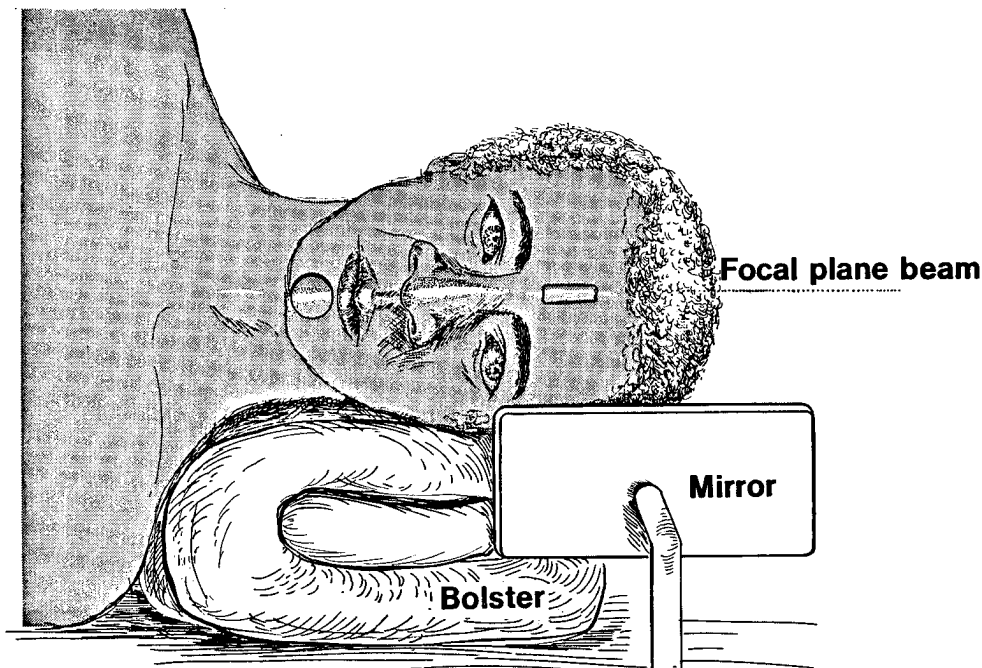

Figure 5. Positioning of subject for X-raying.

indicated the plane of focus, there was a spot beam which showed the center of the area of exposure. The actual size of the area of exposure could be adjusted by a rectangular diaphragm and monitored using a light source before exposure. Figure 6 shows the approximate area of exposure.

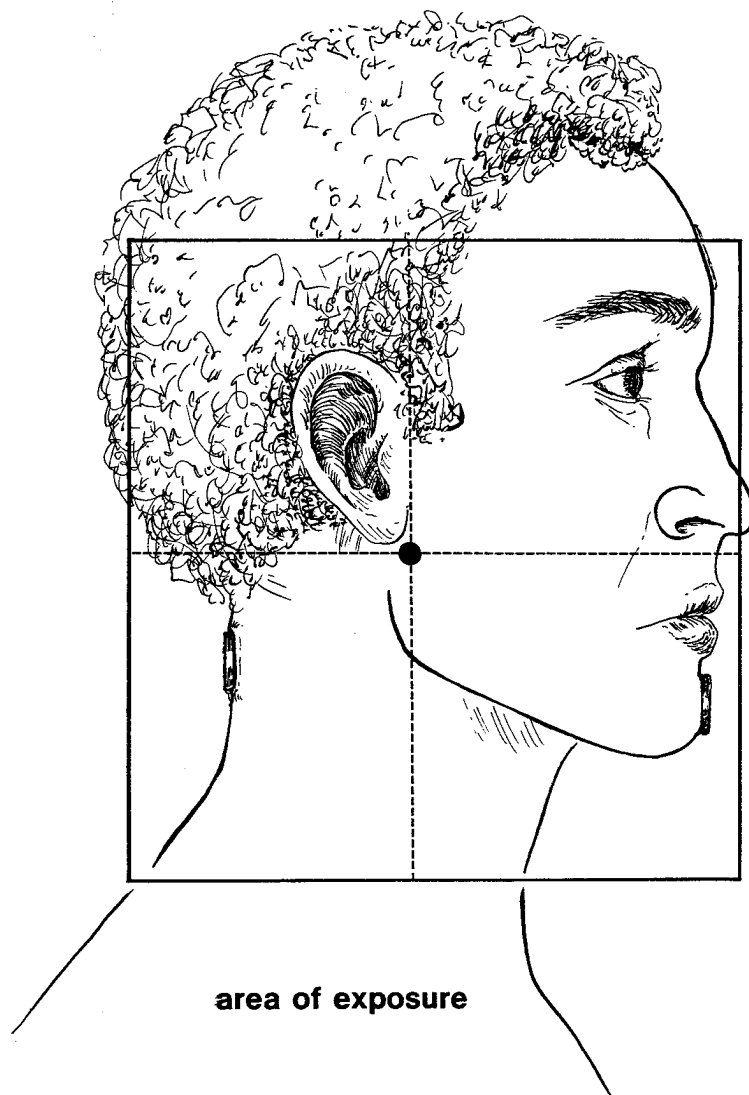

Figure 6. Area of exposure.

THE X-RAY SESSION

After the audio recording was made for a given subject he was X-rayed in order to get a picture of the shape of his vocal tract during vowel production. The procedure for the X-ray session was as follows:

The equipment was set for a predetermined level of exposure. The subject was properly positioned on the table as outlined in the previous section. The table was adjusted vertically so that the beam indicating the plane of focus passed through the coin on the chin and the tape on the forehead. The table was adjusted horizontally so that the spot beam indicating the center of the area of exposure was on the mandible just below the ear. The rectangular diaphragm was adjusted to limit the area of exposure to the desired area.

The entire procedure was rehearsed with the machine in motion so that the subject knew what to expect. Several practice runs were made until I was satisfied that the subject felt comfortable with the procedure. Now the saying of the intended word and its sustained syllable was rehearsed by the subject. This was done before every exposure to prime the subject so he would have the intended word in mind. I monitored the procedure from the subject's side to ensure that the word and vowel he used were the intended ones.

After the initial exposure, the negative was examined to see if any adjustments were necessary in the exposure setting, the positioning of the subject, or the framing of the area of exposure. Once any necessary adjustments were made, we proceeded through the remaining exposures. Each negative was tagged in the corner to identify the speaker and the vowel by using radio-opaque ink on ready-made slips of paper which were designed to fit into a corner slot on the film holder.

Even with the practice and care taken, several mistakes occurred. In the case of one subject we have an incomplete set of X-rays since he made several mistakes and we permitted ourselves to take only one retake.

THE VOCAL TRACT TRACINGS

Once the set of negatives was completed, each X-ray negative was placed on the opaque surface of a fluorescent illuminator and the vocal tract was outlined directly on the film using a soft, thin, lead. When soft tissue was difficult to discern on the negative, which was occasionally the case near the base of the pharynx, the negative was strongly backlighted to enhance the image. These vocal tract outlines were traced onto thin transparent sheets of frosted acetate, with each speaker's tracings for front vowels being superimposed on one acetate sheet and those for back vowels on another acetate sheet. The different shapes were identified with different colors of lead, but in the tracings that appear in this chapter (figures 7-14) they are coded by symbol. The tracings were lined up with a number of different prominent bony processes of the skull, one of which was always the tip of the upper incisors, to enable accurate superimposition.

The different shapes are coded by symbol in the facsimiles of the vocal tract tracings that follow as figures 7 through 14 to identify them for the vowels they represent. The symbol code is such that,
 Hollow symbols refer to the "close, breathy" category;
 Solid symbols refer to the "open, creaky" category;
 Round symbols refer to the higher vowel harmony contrast pair;
 Square symbols refer to the lower vowel harmony contrast pair.
 The *a* figures (on the left pages) are for front vowels and the *b* figures (on the right pages) are for back vowels.

This is summed up in the following key:

front vowels (<i>a</i> figures)	symbol	back vowels (<i>b</i> figures)
i	○	u
ɪ	●	ʊ
e	◻	o
ɛ	■	ɔ

The radial lines present in the tracings are explained later and do not concern us at this point.

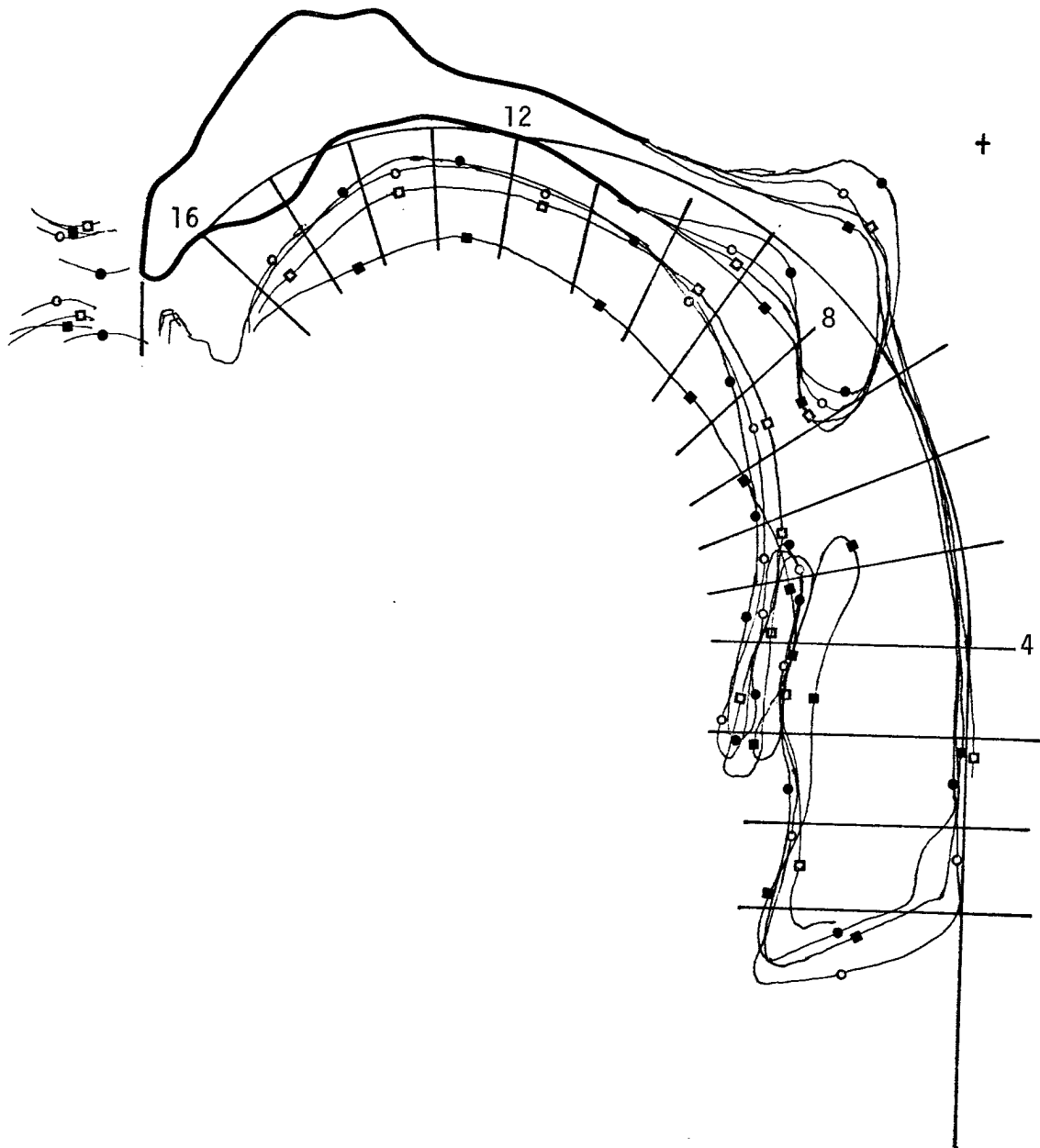

Figure 7a. Speaker 1, front vowels.

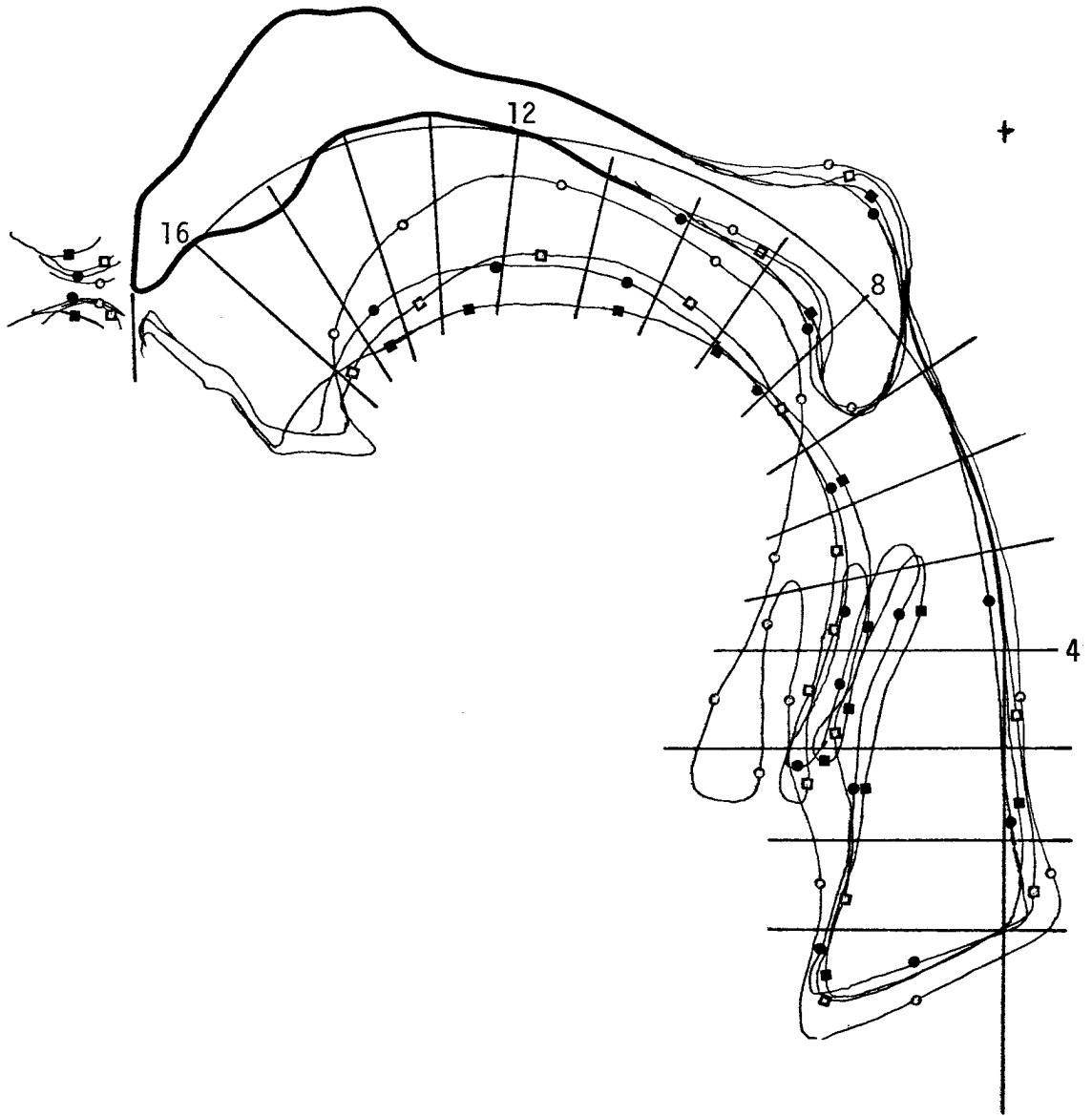

Figure 7b. Speaker 1, back vowels.

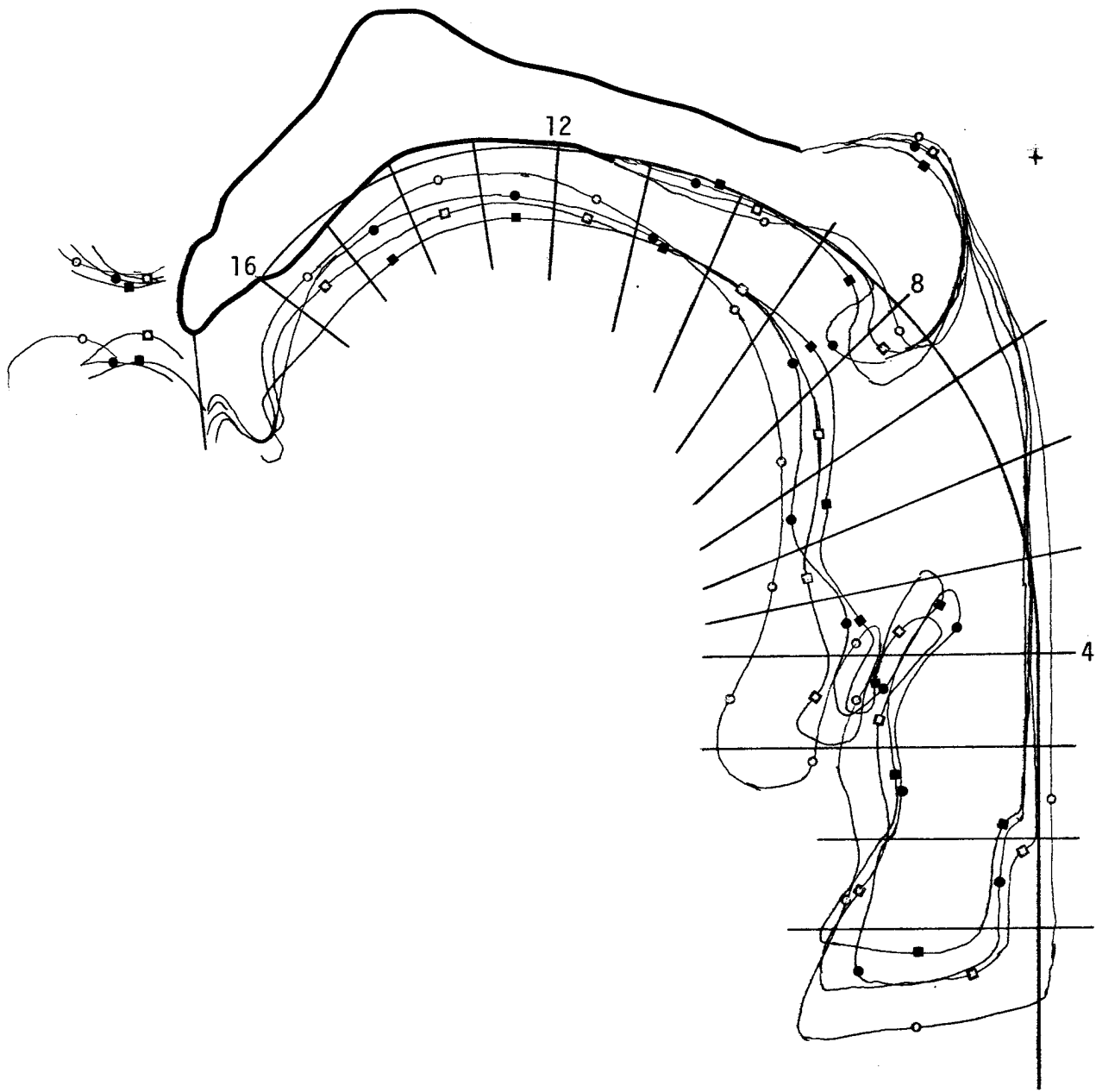

Figure 8a. Speaker 2, front vowels.

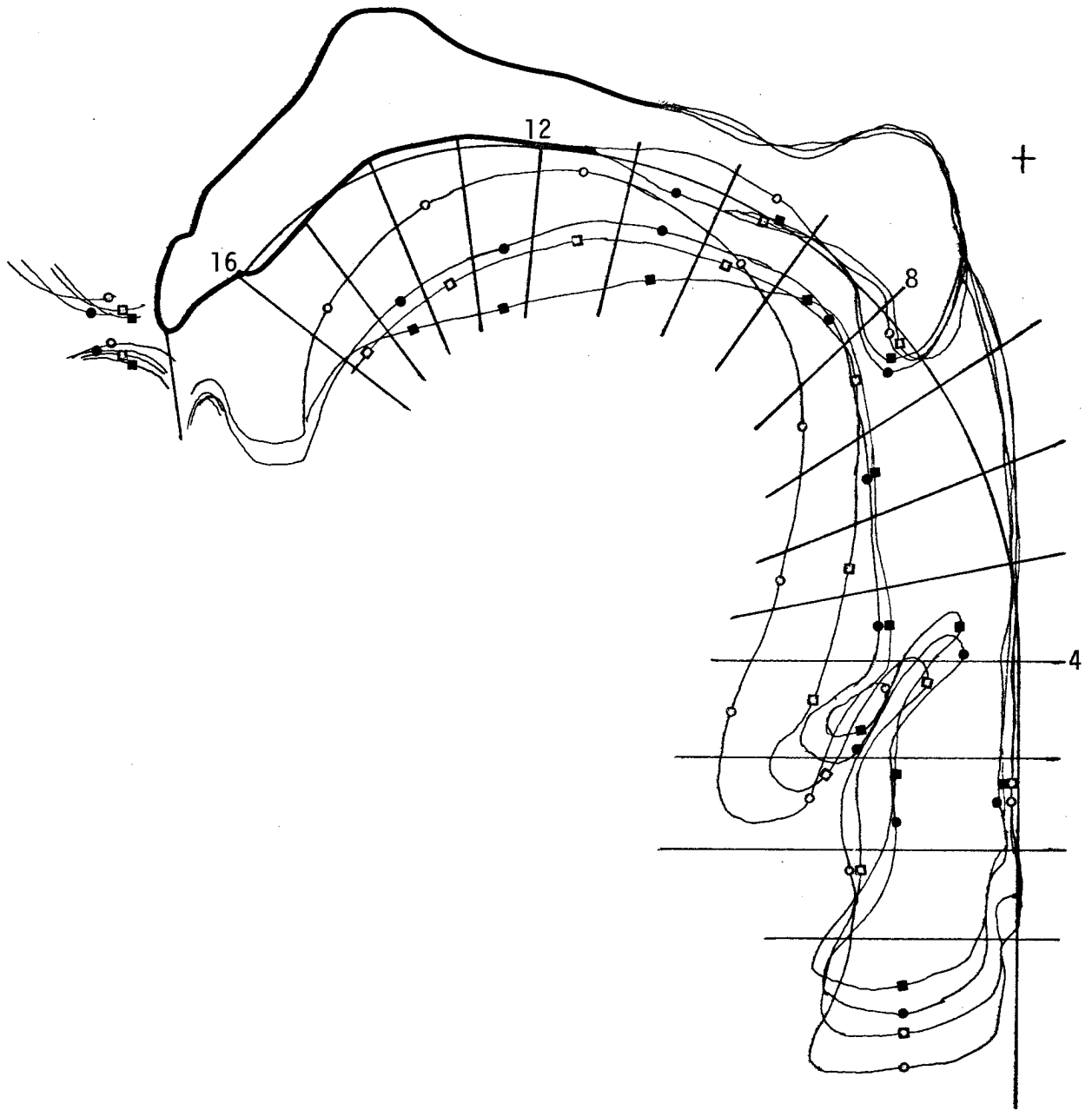

Figure 8b. Speaker 2, back vowels.

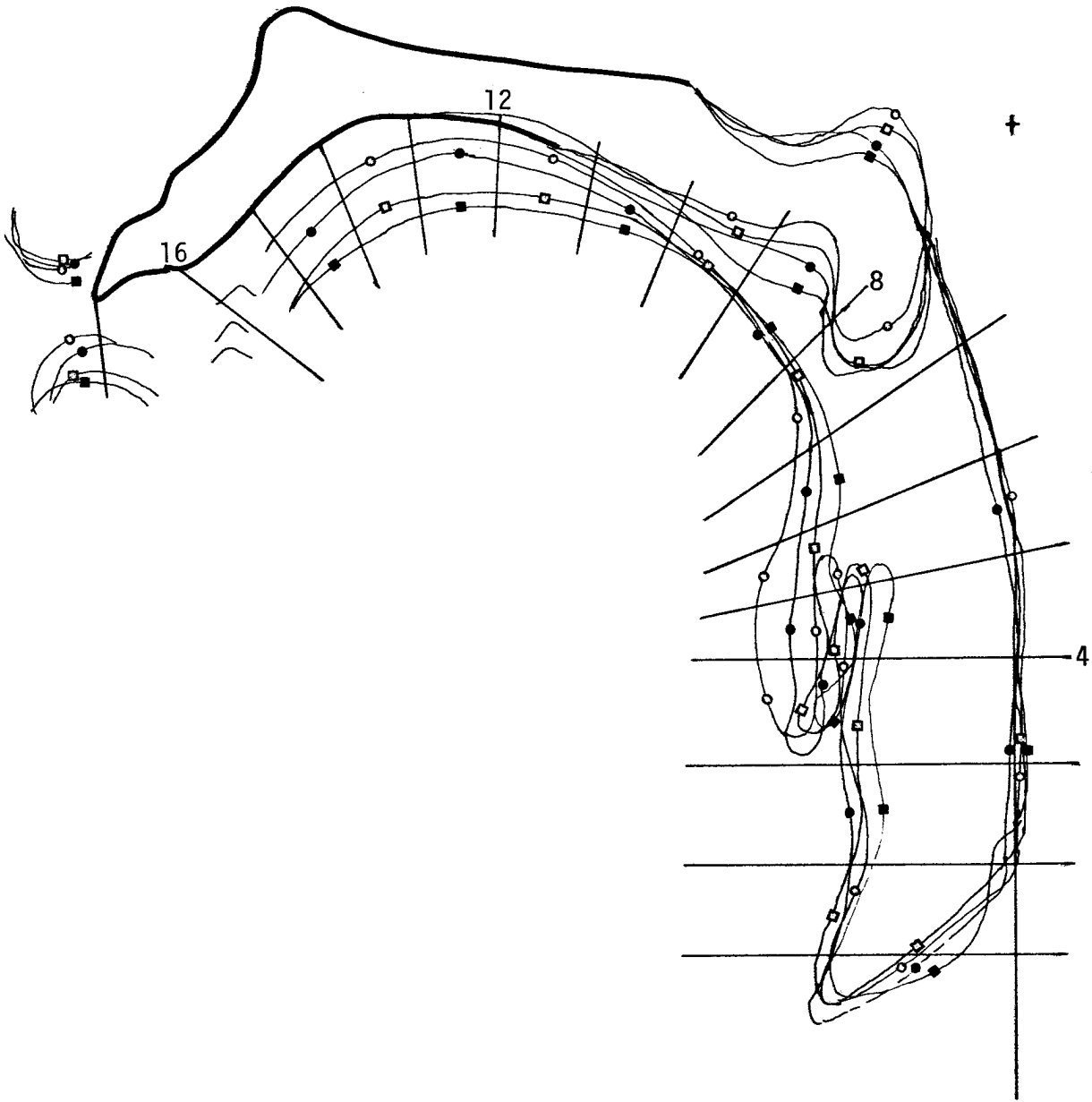

Figure 9a. Speaker 3, front vowels.

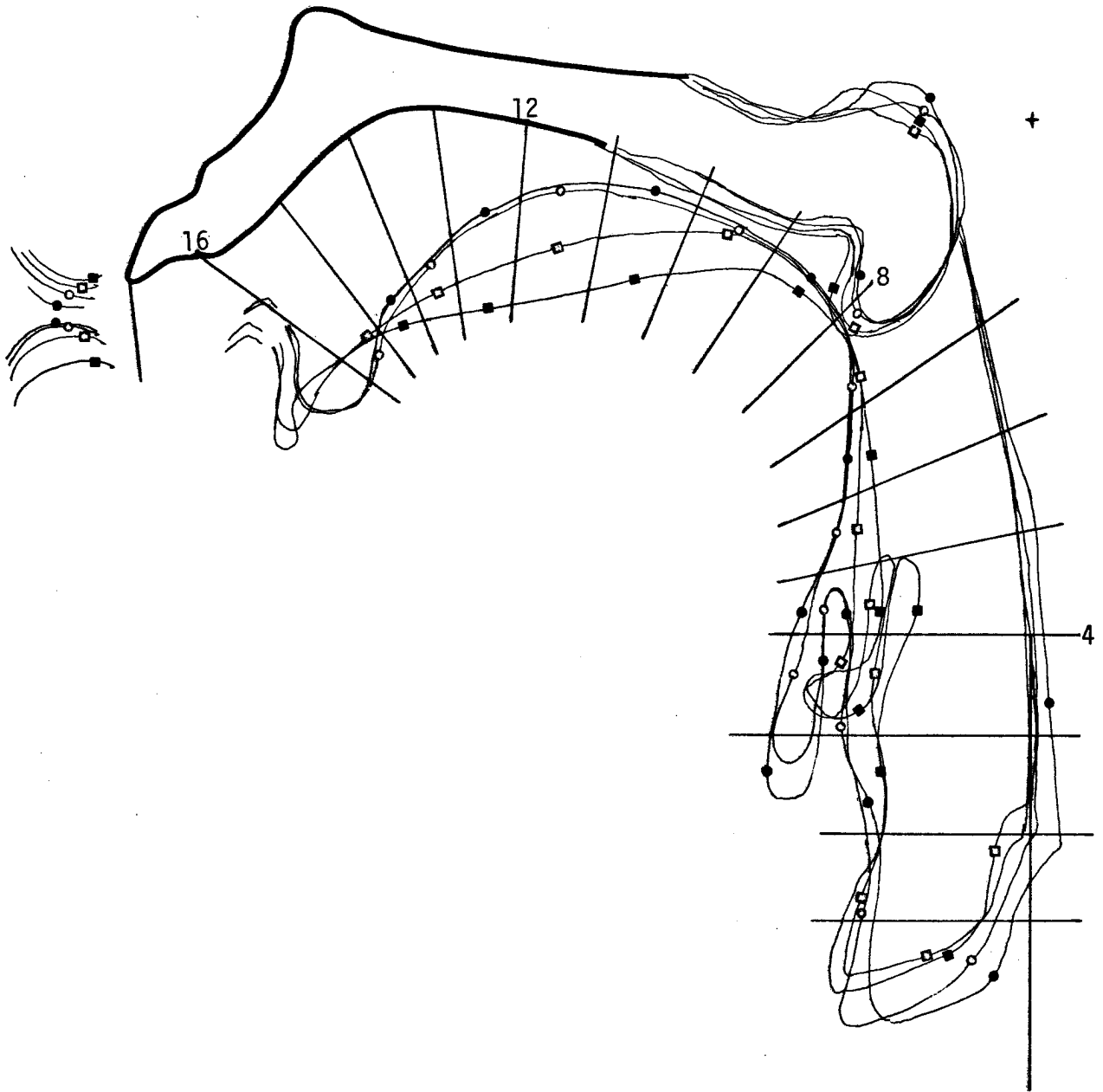

Figure 9b. Speaker 3, back vowels.

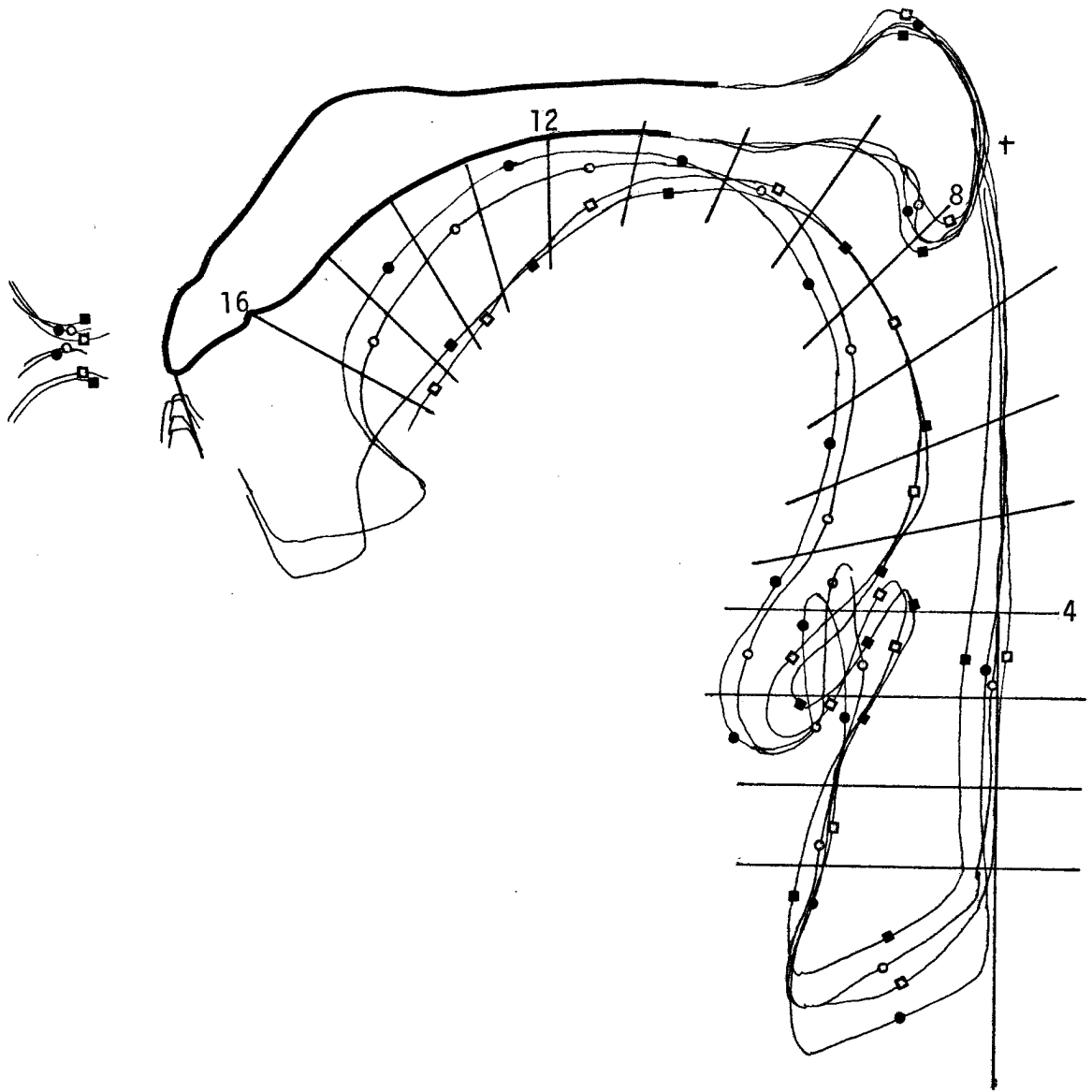

Figure 10*b*. Speaker 4, back vowels.

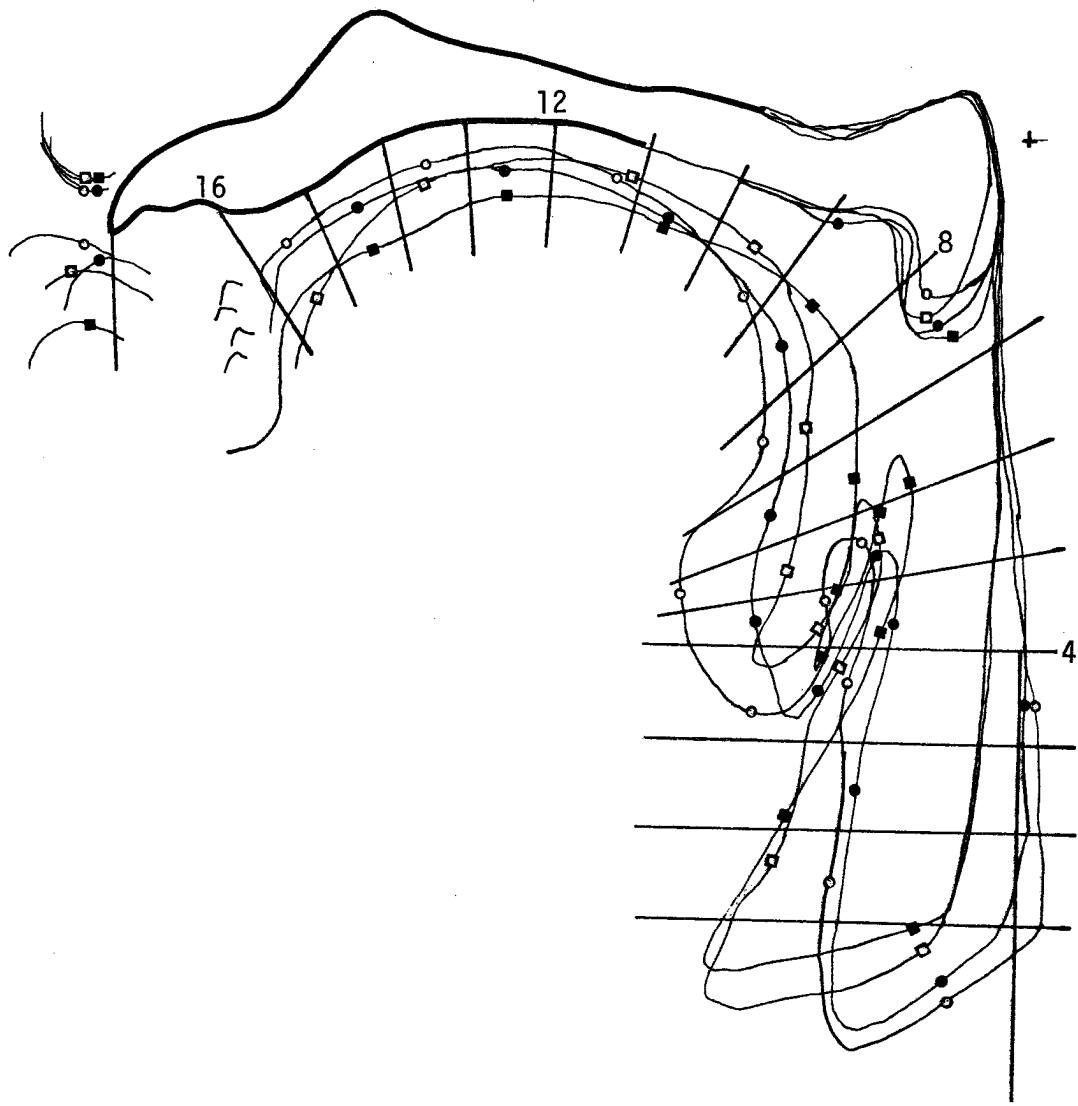

Figure 11a. Speaker 5, front vowels.

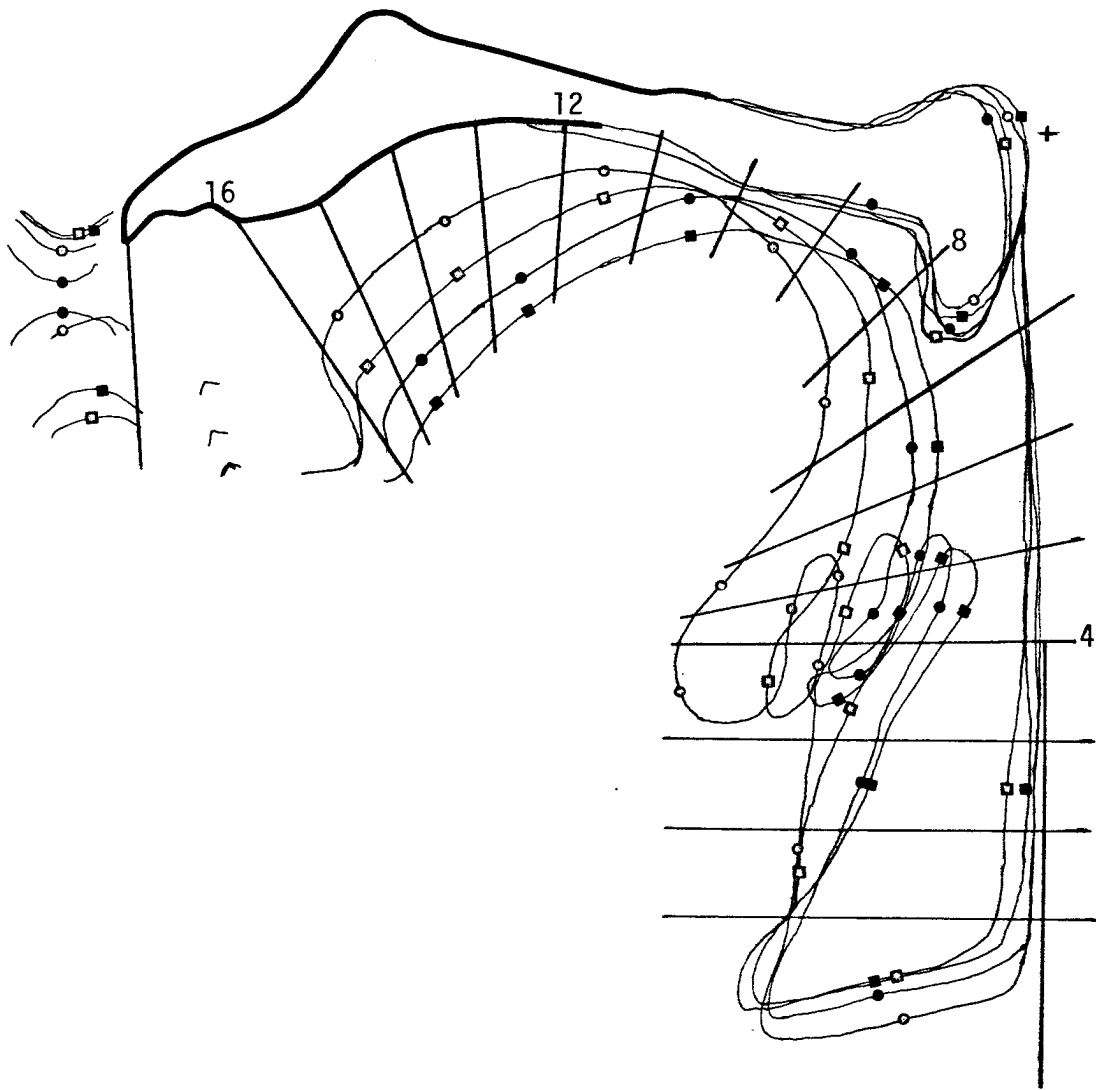

Figure 11b. Speaker 5, back vowels.

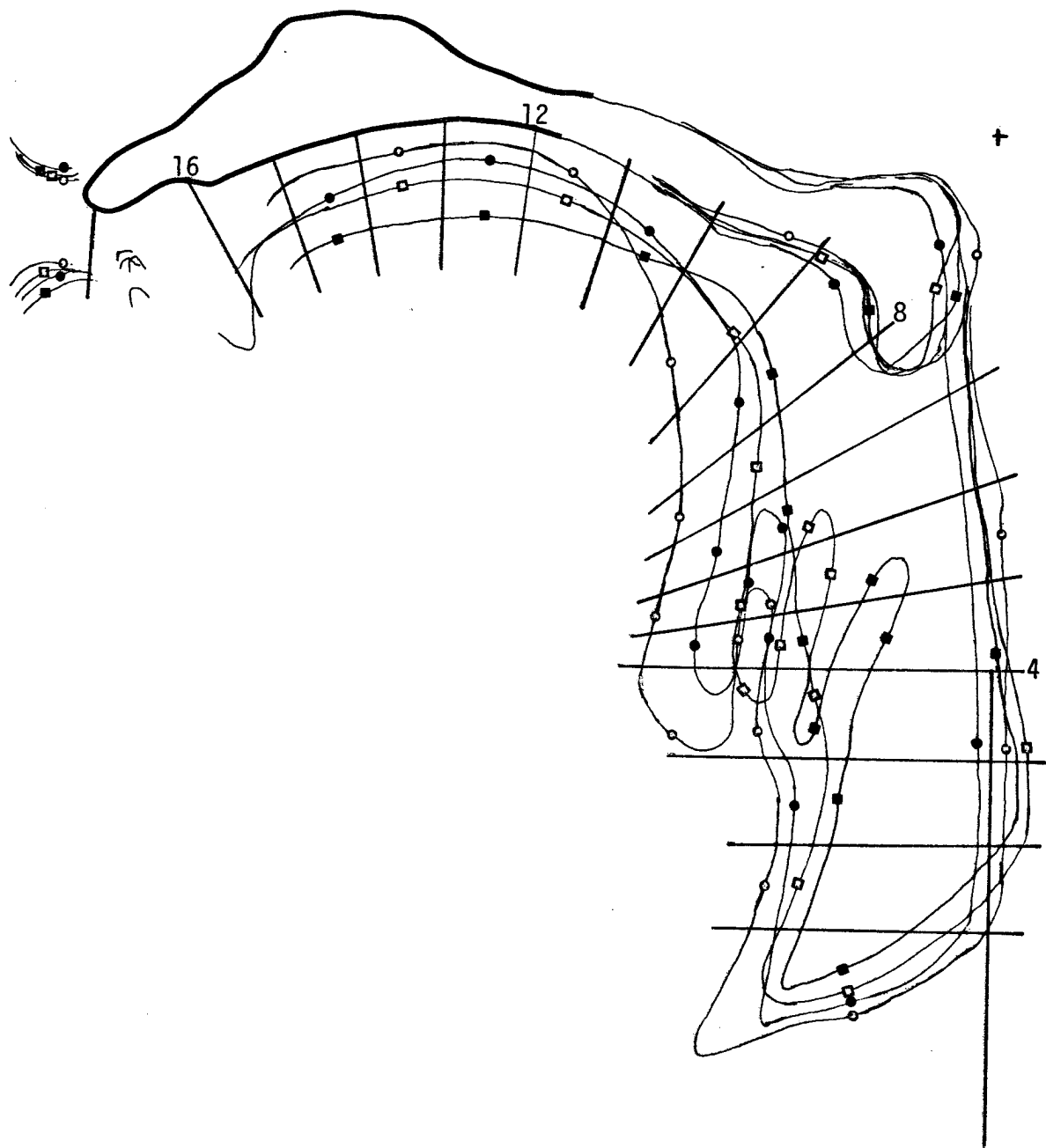

Figure 12a. Speaker 6, front vowels.

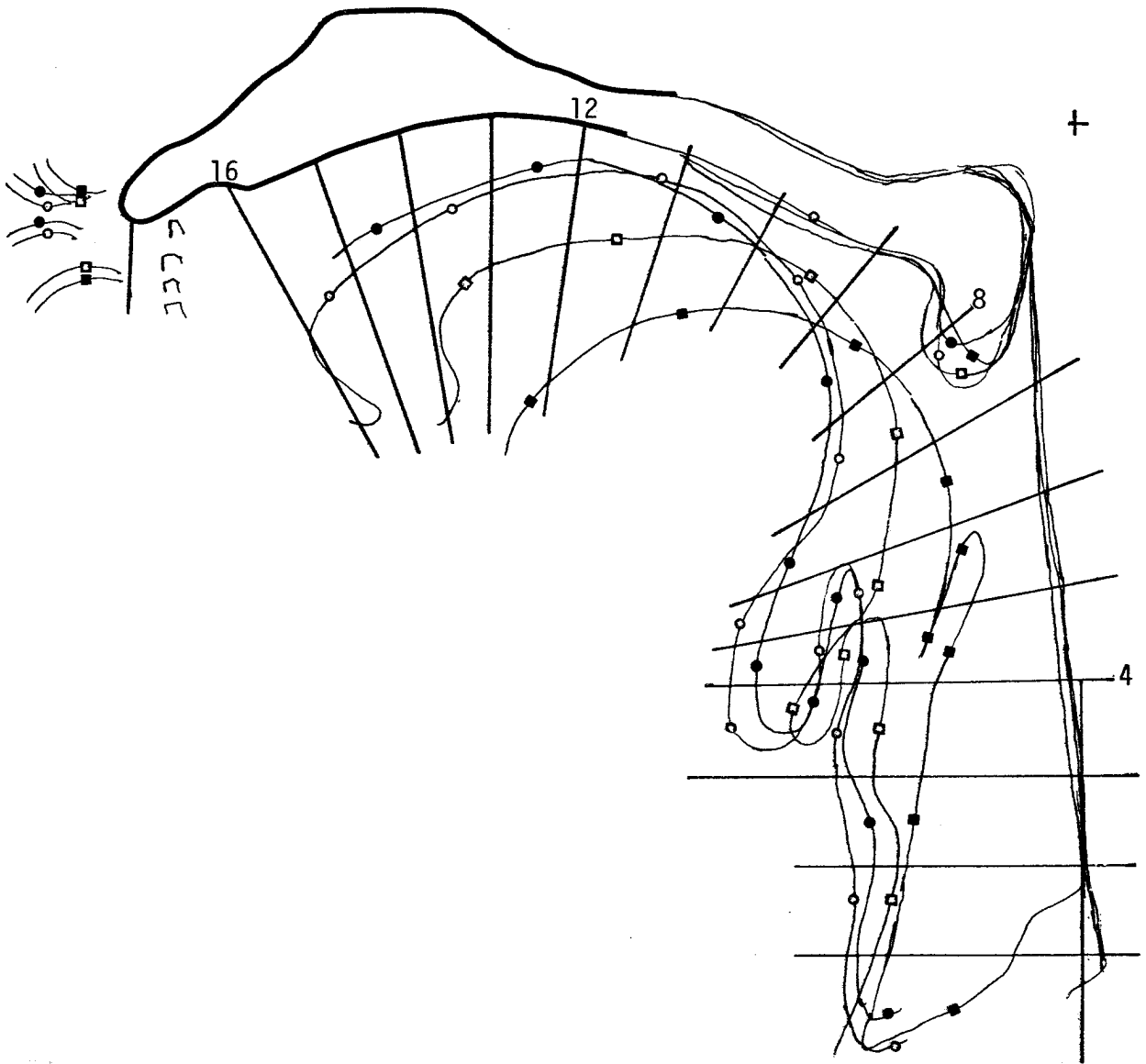

Figure 12*b*. Speaker 6, back vowels.

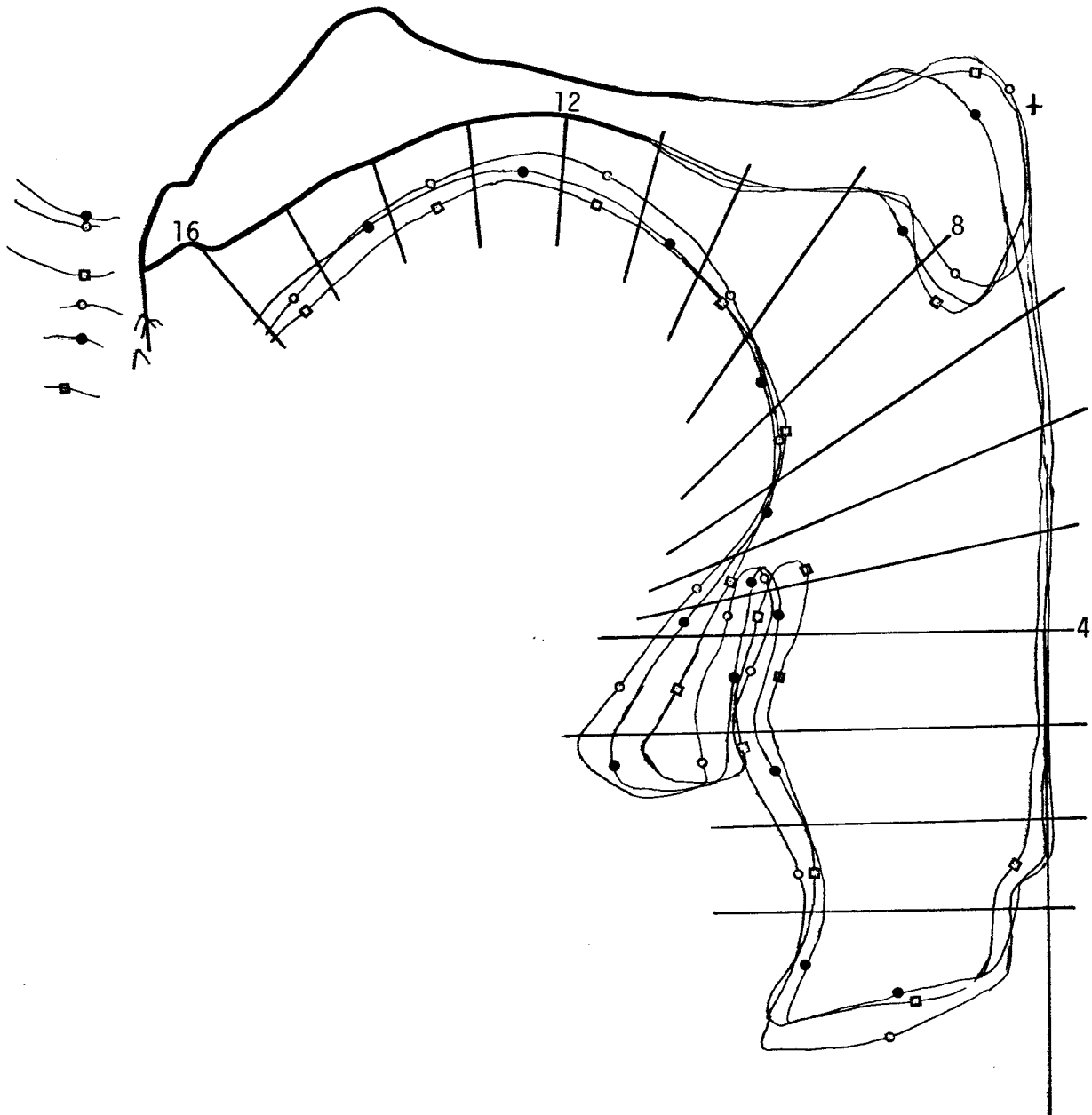

Figure 13a. Speaker 7, front vowels.

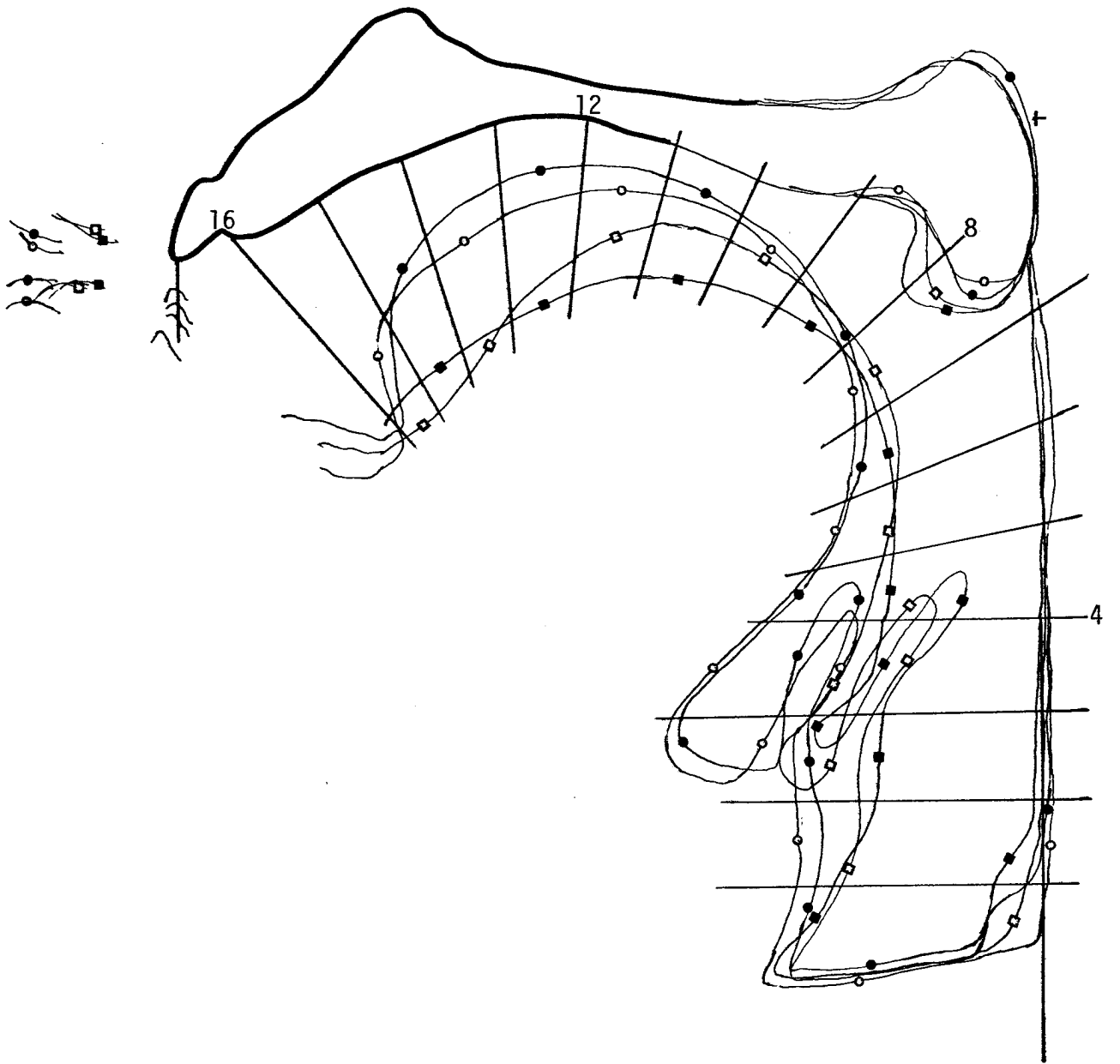

Figure 13*b*. Speaker 7, back vowels.

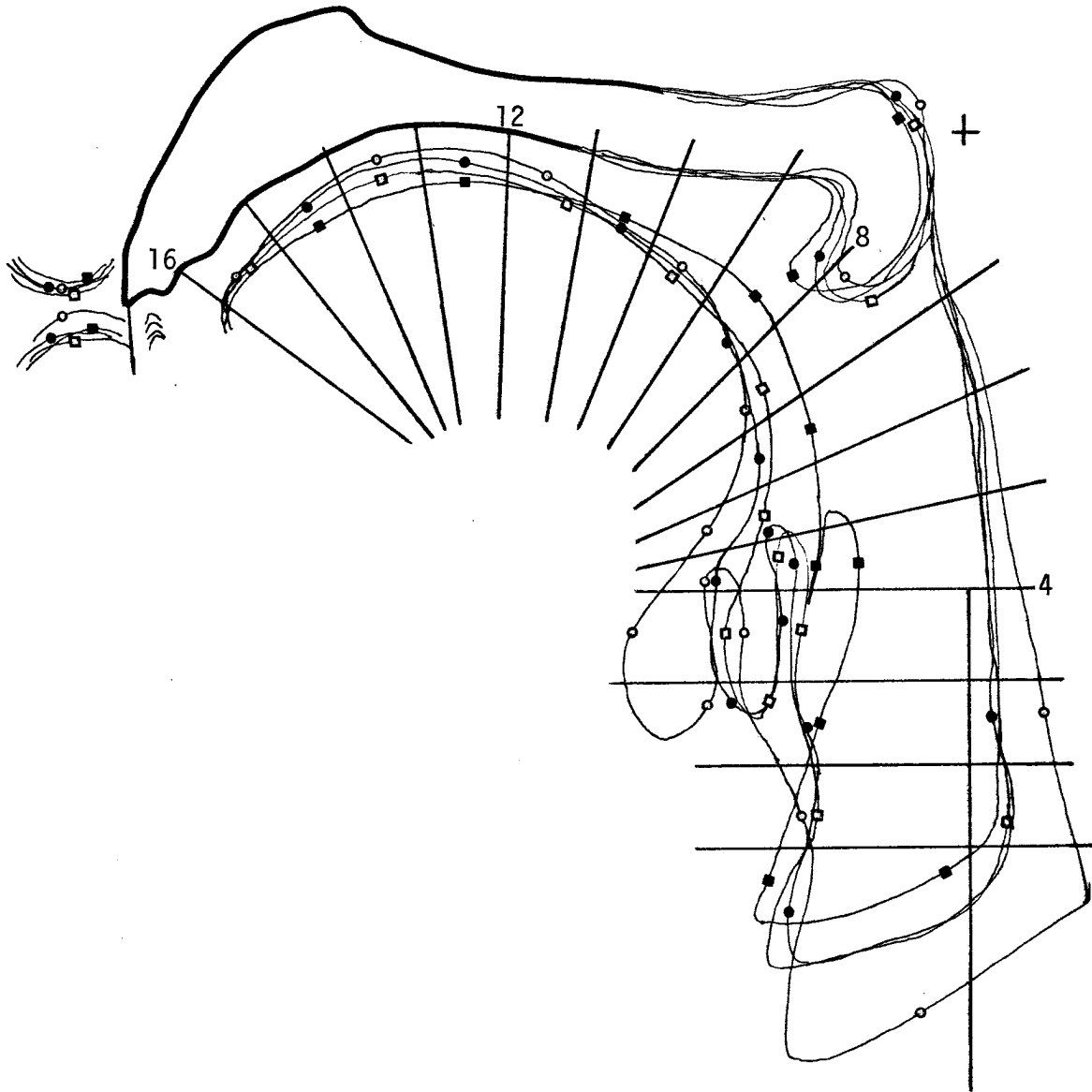

Figure 14a. Speaker 8, front vowels.

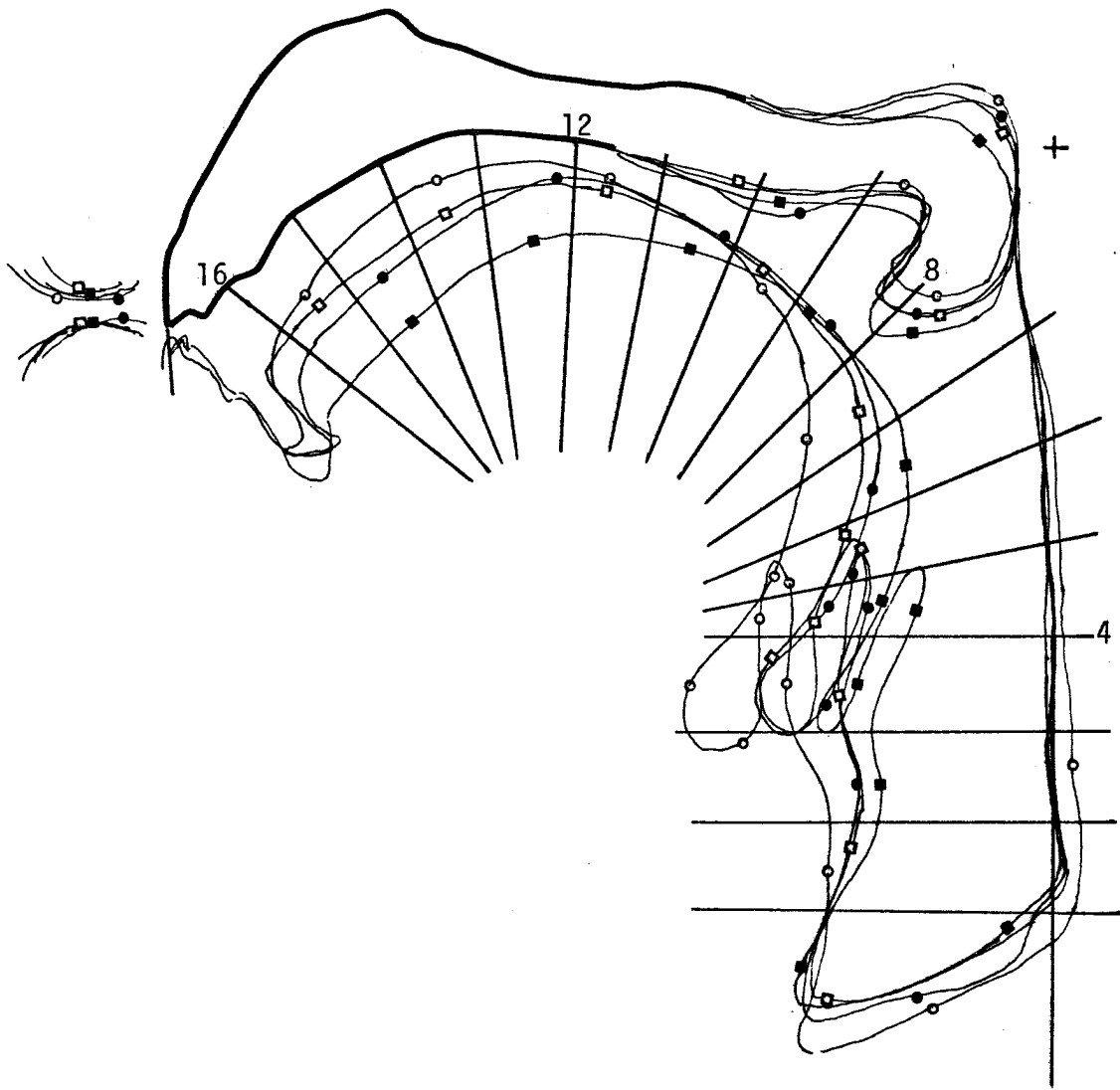

Figure 14b. Speaker 8, back vowels.

Chapter three: Tongue height and pharynx width

The preliminary acoustic study briefly mentioned in the introductory chapter did not satisfactorily determine that the acoustic measure of vowel height (that is, the first and second formant frequencies) could be used to characterize the differences between the vowel categories of DhoLuo. In this chapter articulatory data are discussed to see whether tongue height or pharynx width can be used; that is, to see if there are consistent differences in the height of the tongue or the width of the pharynx between the two phonological vowel harmony categories.

TONGUE HEIGHT

For each subject I constructed an arbitrary reference line parallel to the floor of the nasal cavity and measured for each vowel the normal distance between that line and the highest point of the tongue. These measurements are presented in table 1 and, while they are all on the same scale, only relative comparisons are possible across speakers.

Since we are interested in seeing if there are consistent differences between the categories, I summed up the differences between all the pairs and, using a paired t test, saw if this sum was significantly different from zero. This same test was performed for each of the four vowel-pair subsets. The results for both of these tests also appear in table 1.

Table 1. Tongue height values and paired t test scores (tongue values measured in cm). Counterpredictive cases are indicated by the symbol ~.

Speaker	Front vowels				Back vowels			
	[i]	[ɪ]	[e]	[ɛ]	[u]	[ɔ]	[o]	[ɔ]
1 a	1.27	~ 1.17	1.38	2.25	1.23	2.18	~ 2.02	2.52
2 b	1.38	1.70	1.79	1.87	1.28	1.81	2.03	2.21
3 c	1.25	1.47	1.97	2.17	1.88	~ 1.80	2.31	2.74
4 d	1.17	1.53	1.73	1.86	1.15	~ 0.97	1.34	1.52
5 e	1.21	1.43	~ 1.24	1.71	1.28	1.37	~ 1.31	1.72
6 f	1.30	1.54	1.76	2.17	1.22	1.27	1.71	2.46
7 g	1.21	1.53	1.64	1.73	1.77	~ 1.47	2.21	2.99
8 h	1.22	1.40	1.56	1.67	1.18	1.34	1.37	1.95
p<	0.01		0.02		n.s.		0.01	
p<	0.0005							

We find when considering all thirty-two pairs of vowels that tongue height differences as a whole are highly significant (p < 0.0005).

When we consider the correlation of the vowel harmony pairs, we find significant results for three of the four pairs ([i]/[ɪ], $p < 0.01$; [e]/[ɛ], $p < 0.02$; [o]/[ɔ], $p < 0.01$) -- with only the [u]/[ʊ] pair lacking statistical significance. Note in table 1 that there are seven short wavy lines. These were inserted to call attention to the counterpredictive instances where a phonologically higher vowel has a lower tongue height, or vice versa. We see that five of these seven discrepancies involve the vowel [ʊ], which explains why the [u]/[ʊ] pair is not statistically significant.

PHARYNX WIDTH

A simple measure of the widest part of the pharynx was taken as an index of pharynx width. I obtained this by measuring the normal distance between the back pharyngeal wall and the most advanced part of the root of the tongue anterior to the epiglottis. These measurements (in cm) are presented for each vowel of each speaker in table 2. A correlated paired t test was performed on these data as it was for the tongue height data. The results are summarized in a similar fashion in table 2.

Table 2. Pharynx width values and paired t test scores (width values measured in cm.). Counterpredictive cases are indicated by the symbol ~.

Speaker	Front vowels				Back vowels			
	[i]	[ɪ]	[e]	[ɛ]	[u]	[ʊ]	[o]	[ɔ]
1 a	3.45	3.25 ~	3.60	3.05	4.75	3.05 ~	3.45	3.20
2 b	5.25	2.90 ~	3.55	2.75	4.55	3.05 ~	3.80	2.67
3 c	3.95	3.35	2.80	2.45	4.10 ~	4.40	3.60	3.45
4 d	4.35	3.95	3.30	2.60	3.55 ~	3.73	3.40	2.40
5 e	4.50	3.55	3.05	2.25	4.85	2.85 ~	3.40	2.90
6 f	5.55	4.27	4.25	3.20	5.10	4.65	3.95	2.55
7 g	7.05	6.50	5.85	4.50	6.00	5.75	4.05	3.45
8 h	5.85	4.05	3.80	2.70	5.15	3.90 ~	3.95	3.10
p <	0.01		0.01		0.05		0.01	
p <	0.0005							

In comparing the two tables of data we see that pharynx width is a better indicator of vowel harmony category than tongue height is. We also note that for the vowel harmony pairs we have three significant differences in pharynx width; only the [u]/[ʊ] pair is marginally significant in this respect. Note also that only this pair has any discrepancies present.

In order to demonstrate the comparative differences in pharynx size, I superimposed the back pharyngeal walls in the tracings for the front vowels (figures 15a-15h) and similarly for the back vowels (figures 16a-16h) for each speaker. The solid lines in these figures represent outlines of vocal tract shapes for vowels of the "hollow, breathy" category, while the broken lines represent outlines for vowels of the other, "hard, creaky" category.

Figure 15a
Front vowels
Speaker 1



Figure 15b
Front vowels
Speaker 2

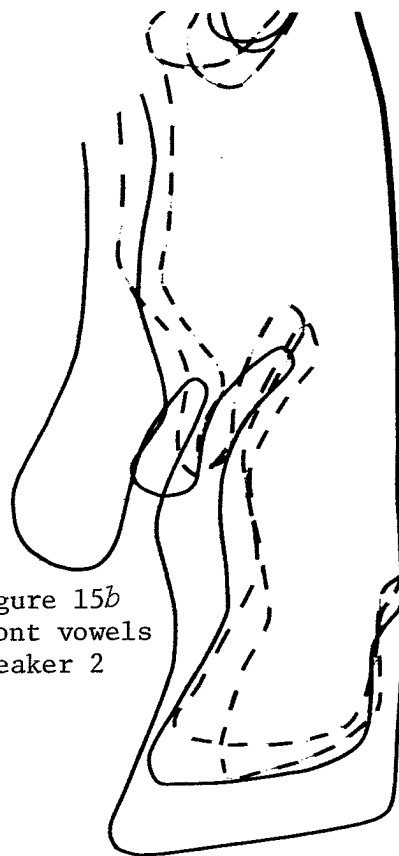

Figure 15c
Front vowels
Speaker 3

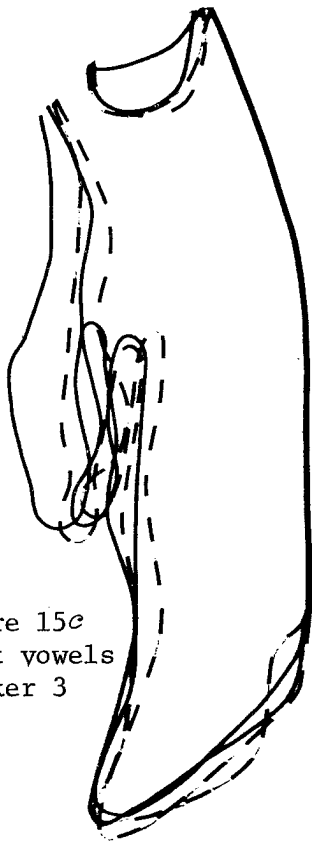

Figure 15d
Front vowels
Speaker 4



Figures 15a-15h. Pharynx outlines for front vowels.

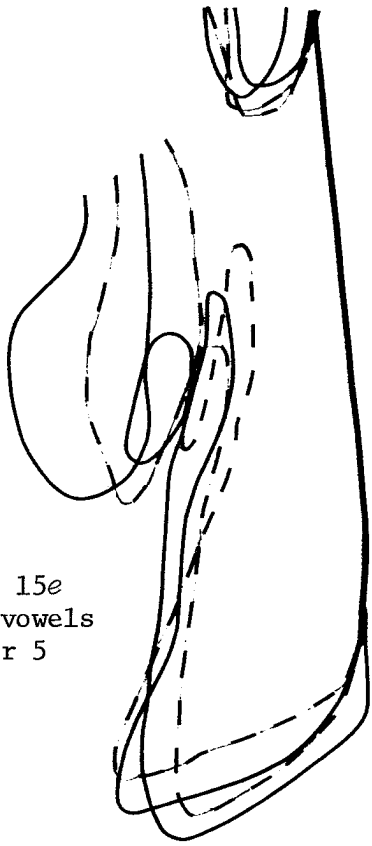

Figure 15e
Front vowels
Speaker 5

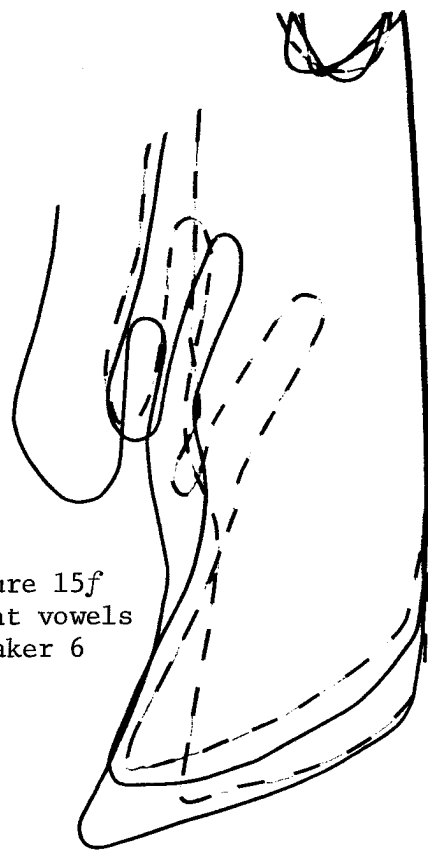

Figure 15f
Front vowels
Speaker 6

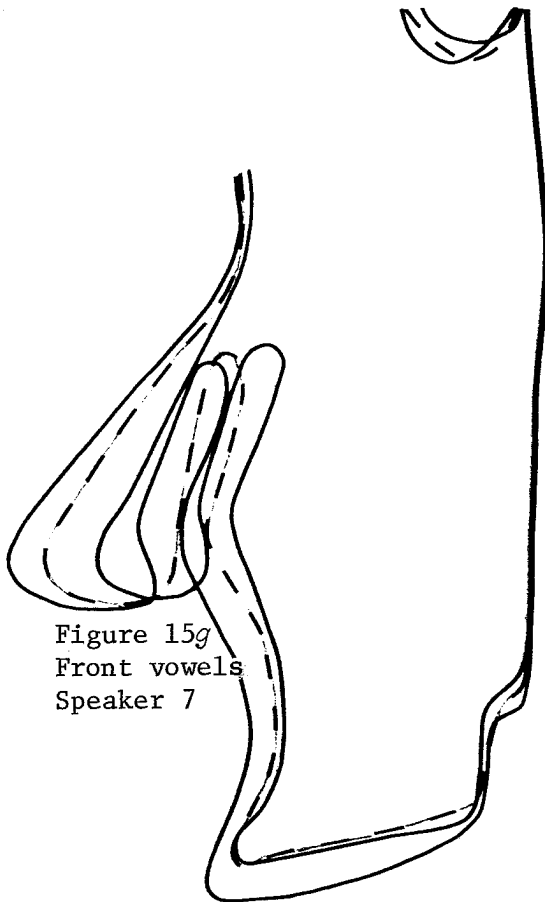

Figure 15g
Front vowels
Speaker 7

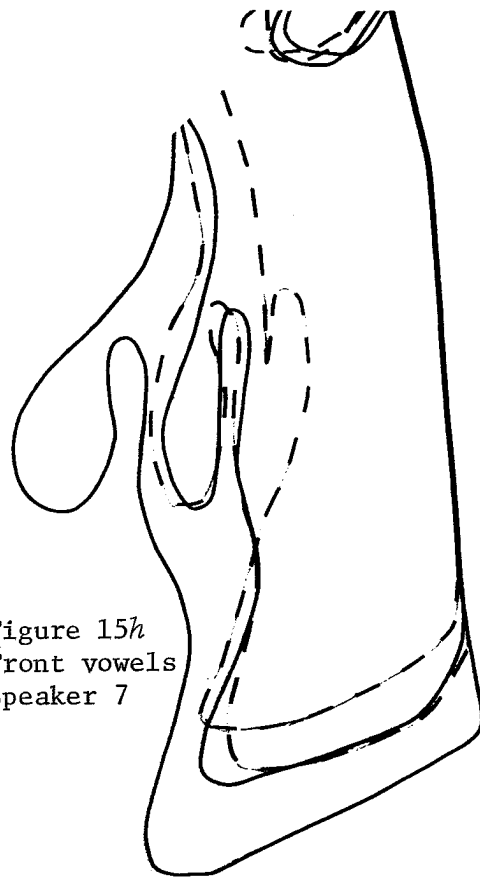

Figure 15h
Front vowels
Speaker 7

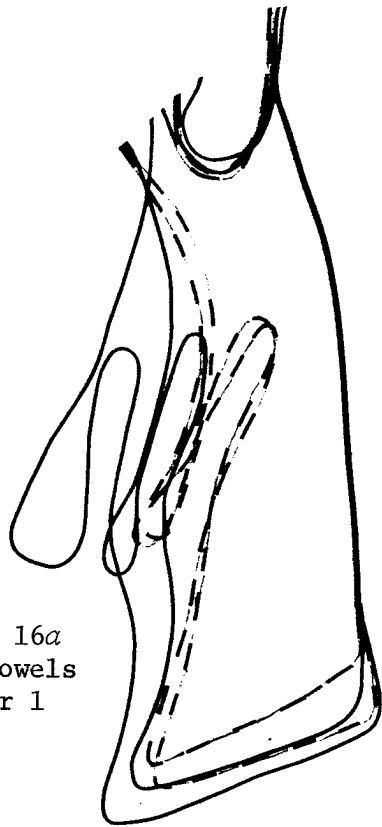

Figure 16a
Back vowels
Speaker 1

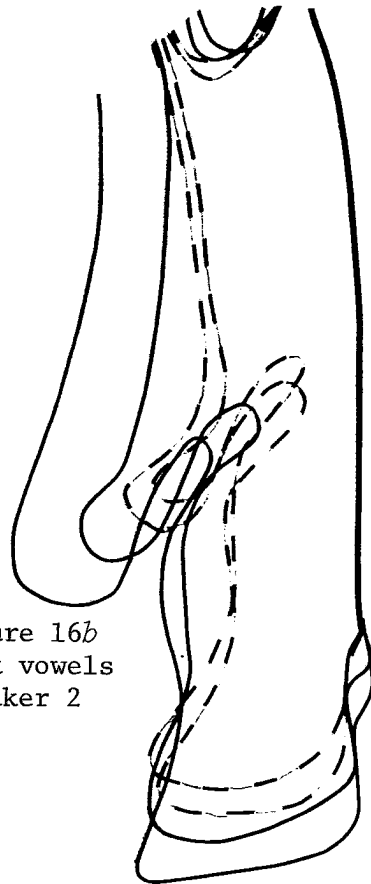

Figure 16b
Back vowels
Speaker 2

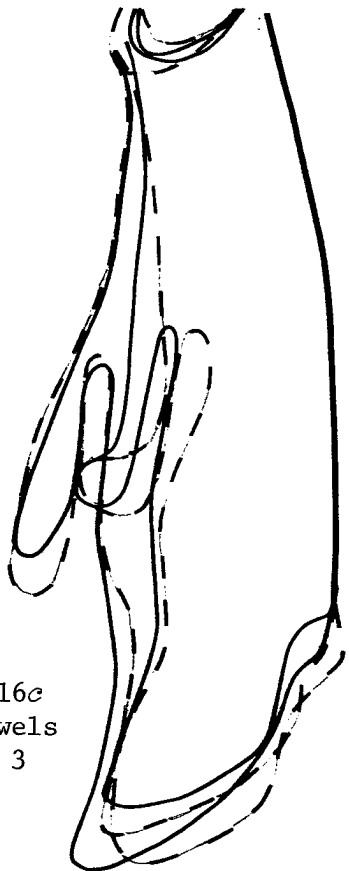

Figure 16c
Back vowels
Speaker 3



Figure 16d
Back vowels
Speaker 4

Figures 16a-16h. Pharynx outlines for back vowels.

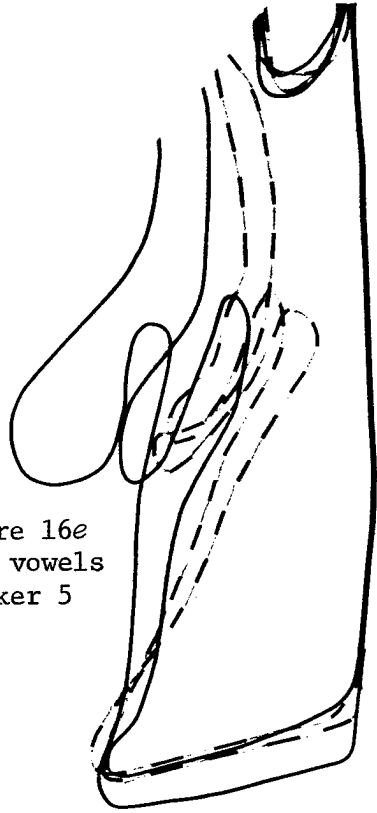

Figure 16e
Back vowels
Speaker 5

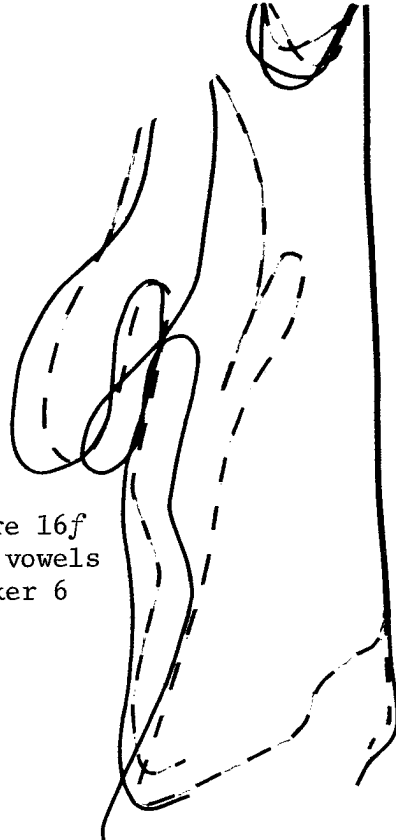

Figure 16f
Back vowels
Speaker 6

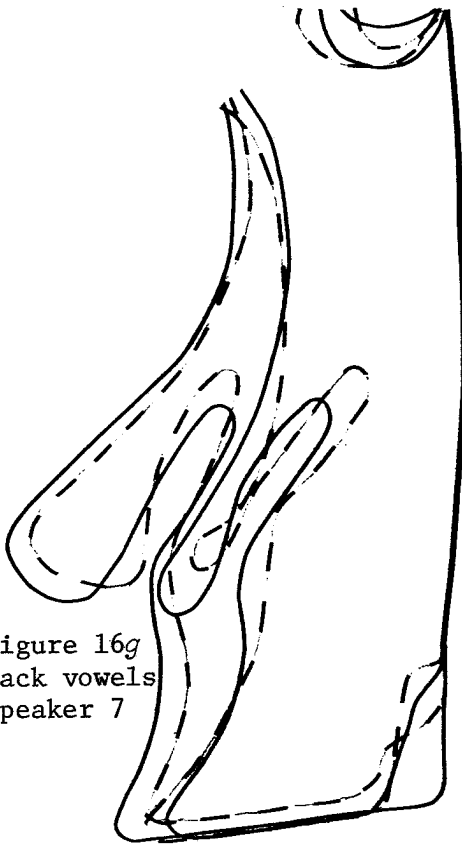

Figure 16g
Back vowels
Speaker 7



Figure 16h
Back vowels
Speaker 8

We see that for front vowels (figures 15a-15h), two speakers, 3 and 4, fail to distinguish the vowel harmony categories by pharynx width, though for half the subjects -- 1, 2, 5, and 8 -- the categories are fully distinguished (pairwise) by pharynx width. In the three cases where pharynx width does not distinguish the harmony categories (see figures 15a, 16c, and 16d) it is in each instance the high vowels that are not distinguished. We can make the empirical claim from this that the two lower contrasting pairs, [e]/[ɛ] and [o]/[ɔ], are in every case distinct with respect to degree of tongue root advancement -- pharynx width being relatively wider for [e] and [o] than [ɛ] and [ɔ], respectively.

TONGUE HEIGHT VERSUS PHARYNX WIDTH

For all eight speakers I have graphed the relationship between the two simple measurements of tongue height and pharynx width, as described in preceding sections of this chapter. These are displayed in figure 17. Tongue height is plotted vertically, pharynx width horizontally. Members of one harmony category are represented by dots and those of the other category by circles. The respective members of a vowel harmony category pair are connected by a straight continuous line if their relationship is as predicted, that is, if a member of the "hard, creaky" category (dots) has a respectively lower tongue height and narrower pharynx than its counterpart in the other category. In those few instances where the relationship of the vowels in a harmony pair is counterpredictive, their symbols are connected with a curved series of points. For speaker 1, for example, the tongue height values are reversed for /I; that is, [i] occurs with a lower tongue height than [ɪ]. This same type of reversal is found for [u] and [ɔ] for speaker 7. Speakers 3 and 4 display for [u] and [ɔ] reversals for both tongue height and pharynx width, so these pairs are connected by two curved series of points.

The graphs in figure 17 clearly show the amount of variation present among individual speakers. For example, only for speakers 1 and 2 does pharynx width separate all the vowels of one category from all the vowels of the other category, yet it would seem for speaker 1 that this is merely accidental and that he relies primarily on vowel height as a distinguisher. For speaker 5, tongue height separates the categories, with all the "breathy" vowels having a higher tongue than any of the vowels of the "creaky" category. Some speakers have their vowels well separated, using both tongue height and pharynx width to a similar degree (speaker 3 is a good example of this), while speaker 8 has three vowels with virtually the same displacement.

The fact that for speaker 8 [ɔ], [ɪ], and [o] all have the same pharynx width and tongue height displacements is not the problem it seems. Lip rounding, which was not considered in this study because of its redundancy, separates the front vowel [ɪ] from the back vowels [ɔ] and [o]. Furthermore, if there is an auditory difference of voice quality between the two categories, this, presumably would distinguish [ɔ] ("creaky") from [o] ("breathy").

This graph reveals no obvious single mechanism for separating vowels into vowel harmony categories, even if the least significant pair, [u]/[ɔ], is excluded.

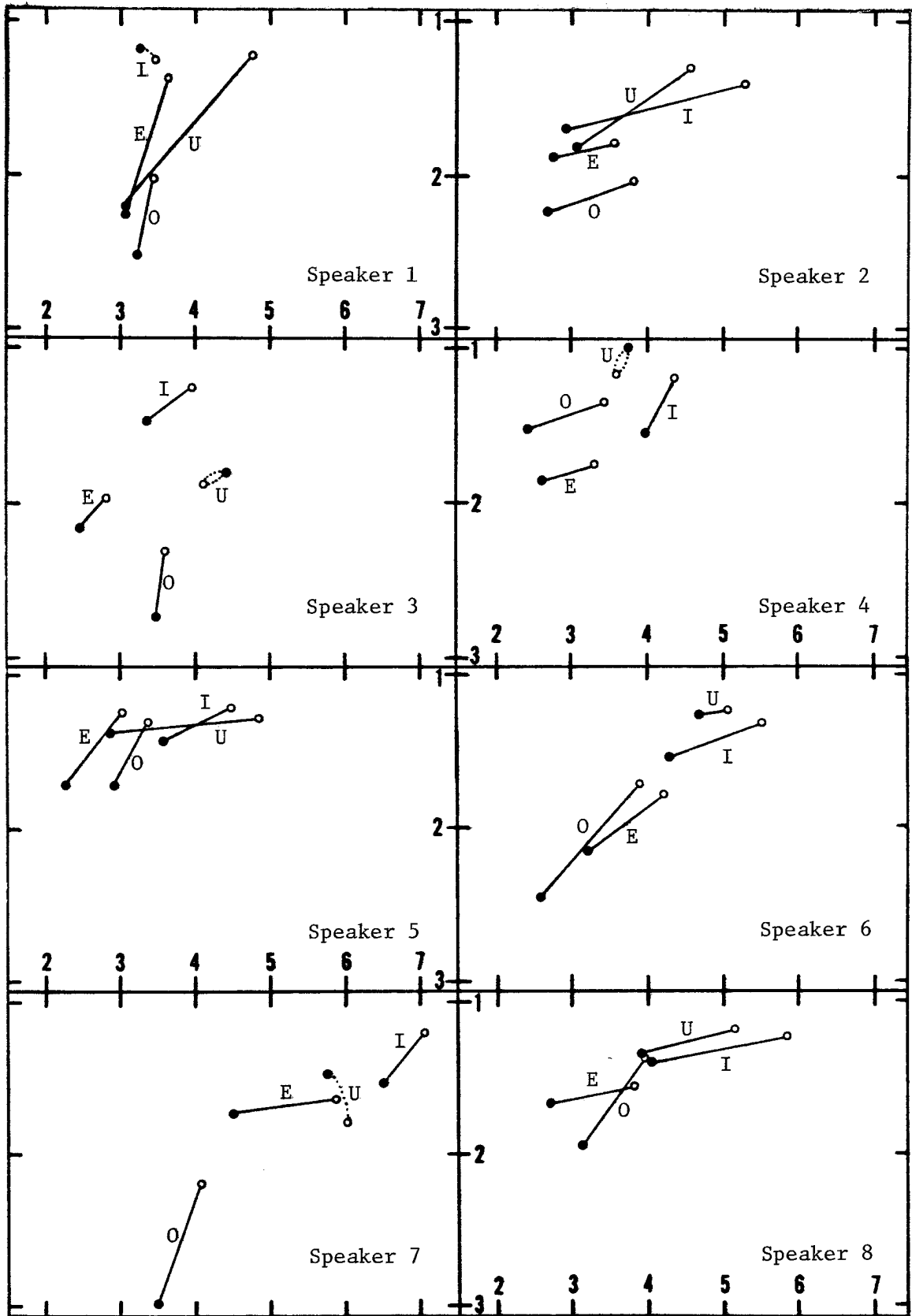

Figure 17. Relationship of tongue height (ordinate) to pharynx width (abscissa) values (in cm from arbitrary reference planes) for 8 speakers

Chapter four: Measurement and analysis

MEASUREMENT OF THE DATA

The radial lines in the figures of the vocal tract tracings at the end of the second chapter (pages 14-29) are part of a measurement grid which was specifically designed for this study with several characteristics in mind. First, I wanted a system to quantify vocal tract shapes which would be compatible with the existing computer programs for speech synthesis and for factor analysis used in the phonetics laboratory at the University of California, Los Angeles. Secondly, and more importantly, the procedure had to be speaker and language independent.

Harshman, Ladefoged, and Goldstein [1977] review previous methods for characterizing vocal tract shapes and present the respective limitations of each. The method that they adopt in their factor analysis procedure for American English has eighteen sagittal measurements and is based on the midline of the vocal tract during production of the vowel [æ] as in the word *had*. The method that I adopt retains the division of the vocal tract into eighteen sections between the lips and the glottis. However, it does not segment a vocal tract midline which is language determined to achieve this division, but rather derives a measurement grid which depends on the physiology of the individual speaker.

The development of an adequate measurement system for characterizing the vocal tract is a nontrivial one. It corresponds in effect to the development of a system for normalizing vocal tract measurements across subjects. It is well known that it is very difficult to devise an adequate system for normalizing acoustic measurements (see Disner [1978] for a comprehensive review of this problem). It is equally true that it is difficult to normalize physiological measurements. The validity of the system proposed below has not yet been fully established. But it is at least descriptively adequate; and, as will be apparent from the results of analyses to be reported later, it allows us to make some explanatory statements about vowel harmony in DhoLuo.

My method is dependent only on the shape of the surface of the passive articulators; that is, the maxilla and the back wall of the pharynx. As such it is similar to earlier polar coordinate systems [Stevens and House 1955, Heinz and Stevens 1964, 1965, Lindblom and Sundberg 1969] which are determined by constructing a circle tangent to both the maxilla and the back wall of the pharynx. However, while such a circle can be constructed for some head positions for some speakers, it is not possible for the general population. The coordinate system that I present here uses two foci: one for an arc that is tangent to the hard palate (maxilla), the other for a larger arc that is tangent to the back wall of the pharynx (these arcs are drawn in for the first two speakers, represented by figures 7 and 8 on pages 14-17). Only in exceptional cases will these foci coincide or will the length of the radii for the different arcs be the same.

I made tracings of the passive articulatory surface for all of the X-ray negatives for each speaker. A representative tracing for each speaker is presented in figure 18; one can see how much variation there is in head size and shape from person to person. It was on the basis of

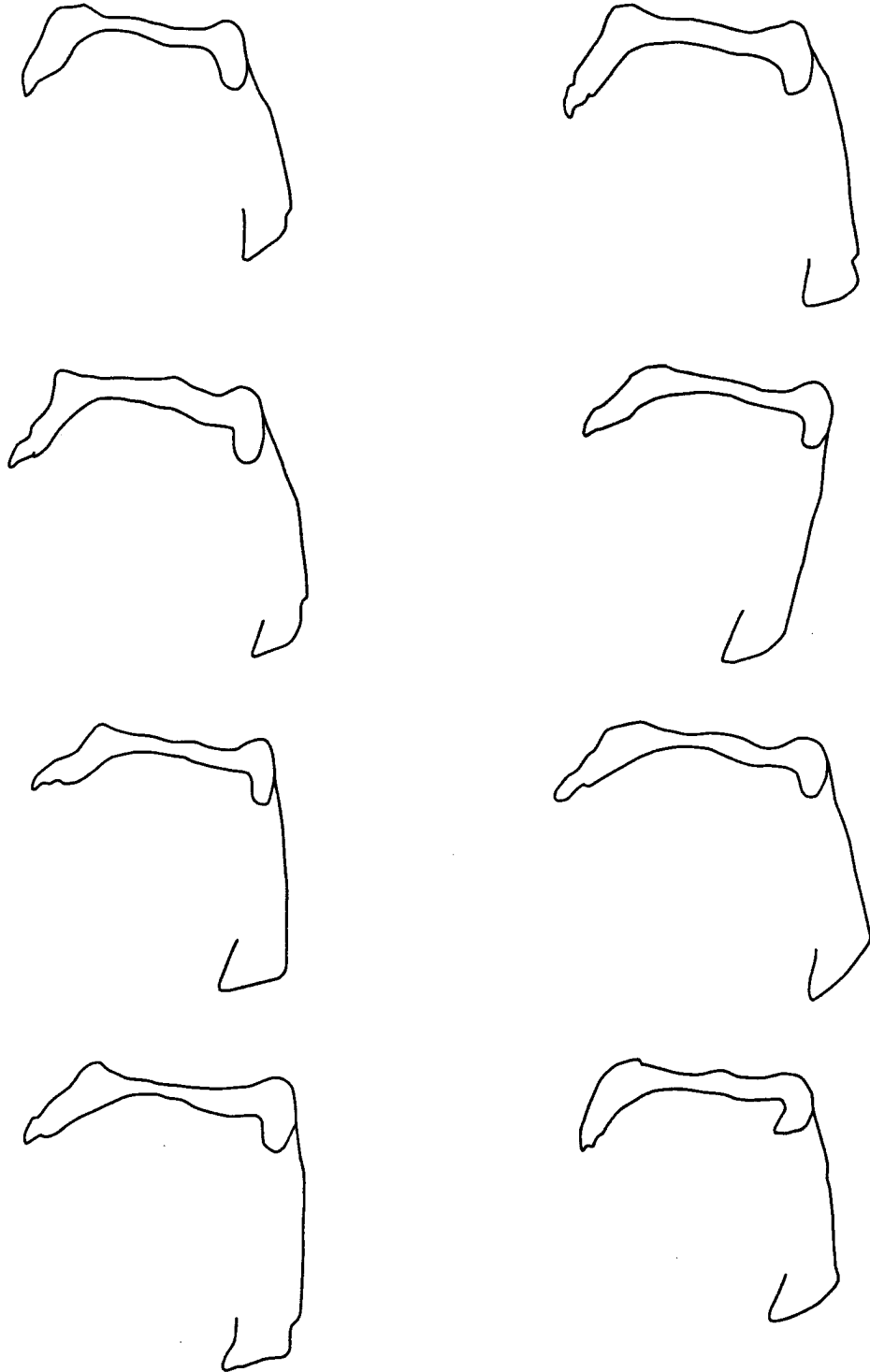
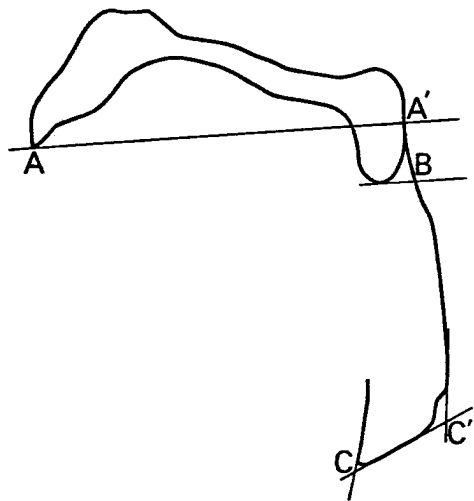

Figure 18. Cross section of passive surface of articulation for eight speakers of DhoLuo.

these tracings that the measurement grids were constructed. While some tracings deviated from the representative tracing, this was very small in most cases; the particular tracing selected to represent each speaker was chosen to minimize this deviation.

The measurement grids were constructed by geometric principles using only straightedge and compasses; in each speaker's grid given points of the vocal tract are set in correspondence with the equivalent points of every other speaker even though there is individual variation present in the sizes and shapes of the maxillae and pharynges. Essentially, the strategy was to specify midpoints for the maxilla and back wall of the pharynx and to apportion the cross sections of the vocal tract in relation to these midpoints. Figures 19*a* and 19*b* show the progression of the construction of the measurement grid. The points of construction are assigned letters to agree with the progression steps; in the case of several letters for one step, the rightward or outward letter is given a prime superscript. Reference is generally made to points from left to right or inward to outward. The several steps which are shown for each vocal tract outline are grouped together after the number which corresponds to that outline (as a decimal value in the figure).

1. a) Draw a line, AA', from the toothtip to the center of the back of the uvula.
b) Draw a line parallel to AA' and which is tangent to the bottom of the uvula and intersecting the back wall of the pharynx (point B).
c) Outline the bottom of the pharynx with intersecting lines which are extensions of the front and back walls and the base of the pharynx (intersections are points C and C').
2. d) Bisect AA' with a line which intersects the palate (point D).
e) Bisect the distance between B and C' with a line which intersects the back wall of the pharynx (point E).
f) Bisect CC' (point F).
3. g) Draw a line, FG, from the juncture of the teeth and the alveolar ridge (point G) to the midpoint of the pharynx baseline.
h) Bisect FG (point H).
4. i) Determine the points of intersection, I and I', of two arcs of length GD from points G and D.
j) Draw lines connecting point I with points G and D. Draw line II' to intersect the palate (point J).



19.1

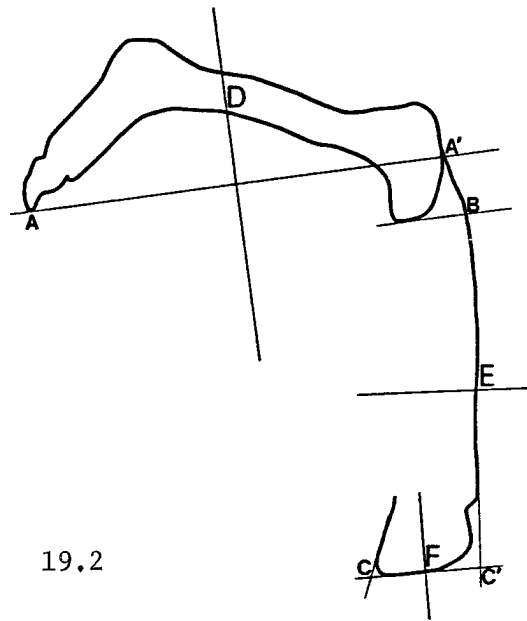

19.2

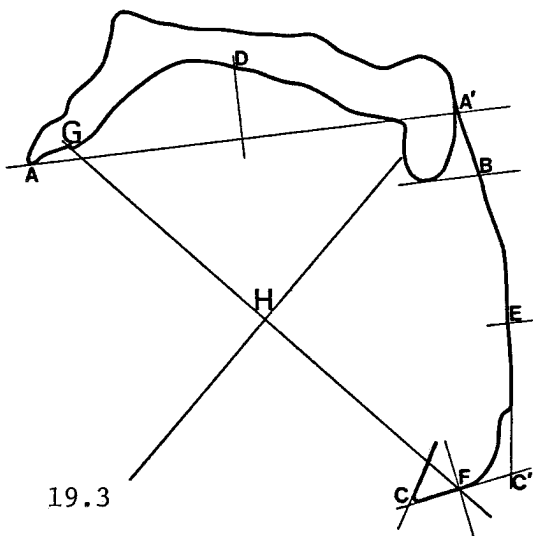

19.3

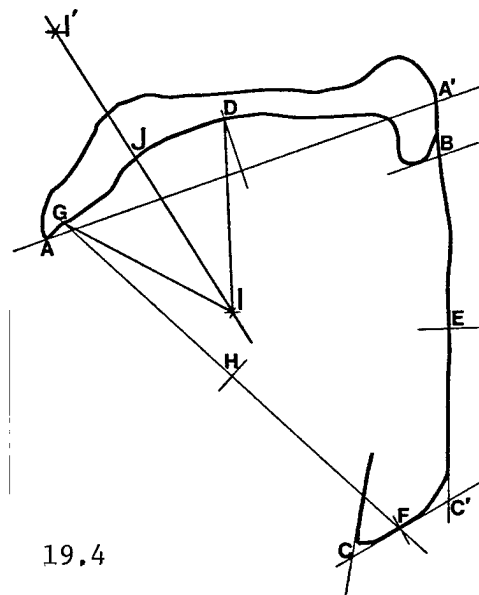

19.4

Figure 19a. Construction of vocal tract measurement grid.

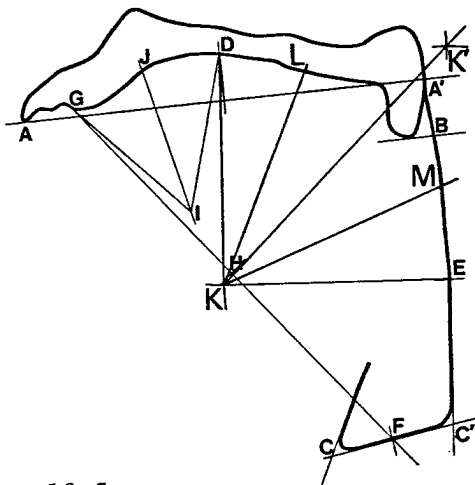

19.5

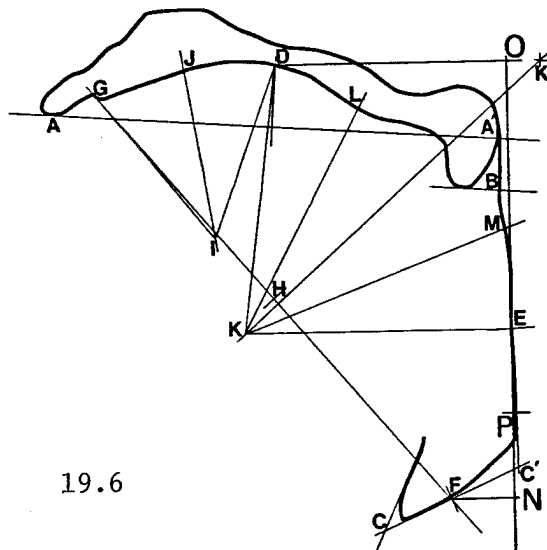

19.6

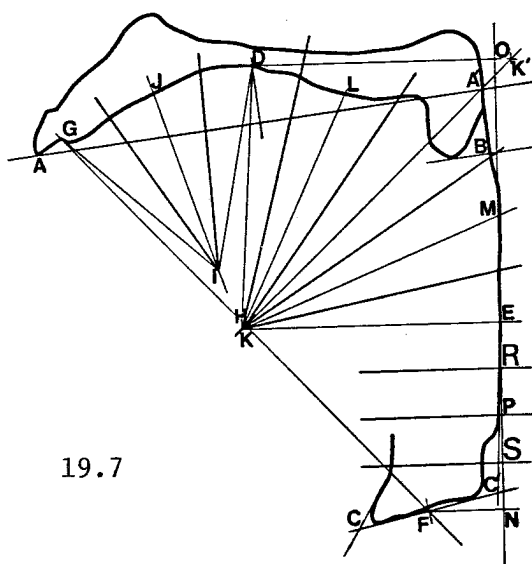

19.7

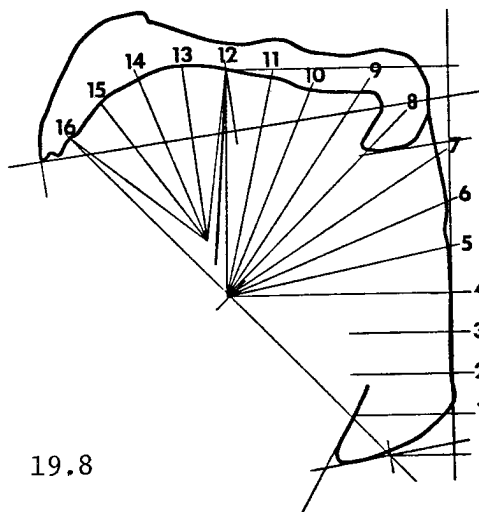

19.8

Figure 19b. Construction of vocal tract measurement grid (continued).

5. k) Determine the points of intersection of two arcs of length HF from points D and E, and connect these points with a straight line.
 - l) Connect points D and K with a straight line and bisect the resulting angle $\angle DKK'$. Where this bisecting line intersects the soft palate is point L.
 - m) Connect points E and K with a straight line and bisect the resulting angle $\angle EKK'$. Where this bisecting line intersects the back wall of the pharynx is point M.
6. n) At point E, construct a line normal to KE and which extends above the uvula and below the larynx. Draw a line through point F parallel to KE and which intersects the line just constructed (point N).
 - o) Draw a line through point D parallel to KE and which intersects the line constructed in the preceding step (point O).
 - p) Bisect EN (point P).
7. q) Bisect each of the angles which originate from points I and K ($\angle GIJ$, $\angle JID$, $\angle DKL$, $\angle LKK'$, $\angle K'KM$, $\angle MKE$).
 - r) Bisect EP (point R).
 - s) Bisect PN (point S).
 - t) Through points R, P, and S draw lines parallel to KE.
8. u) Bisect the angle $\angle IDK$.
 - v) Number the parallel lines through points S, P, and R as 1, 2, and 3, respectively.
 - w) Progressively number the lines radiating from points I and K beginning with KE as number 4 and ending with IG as number 16. The line constructed in step u (by bisecting $\angle IDK$) is line number 12 and replaces ID and KD.
 - x) Draw a short line from the tooth tip perpendicular to AA' (line number 17).

The final measurement grid is shown overleaf in figure 20 with the construction lines removed. The measurements for characterizing vocal tract shape were made along lines 1 through 16 as the distance between the articulators. Measurements for distances between the teeth were made on a line (number 17) drawn in for the purpose (see step x).

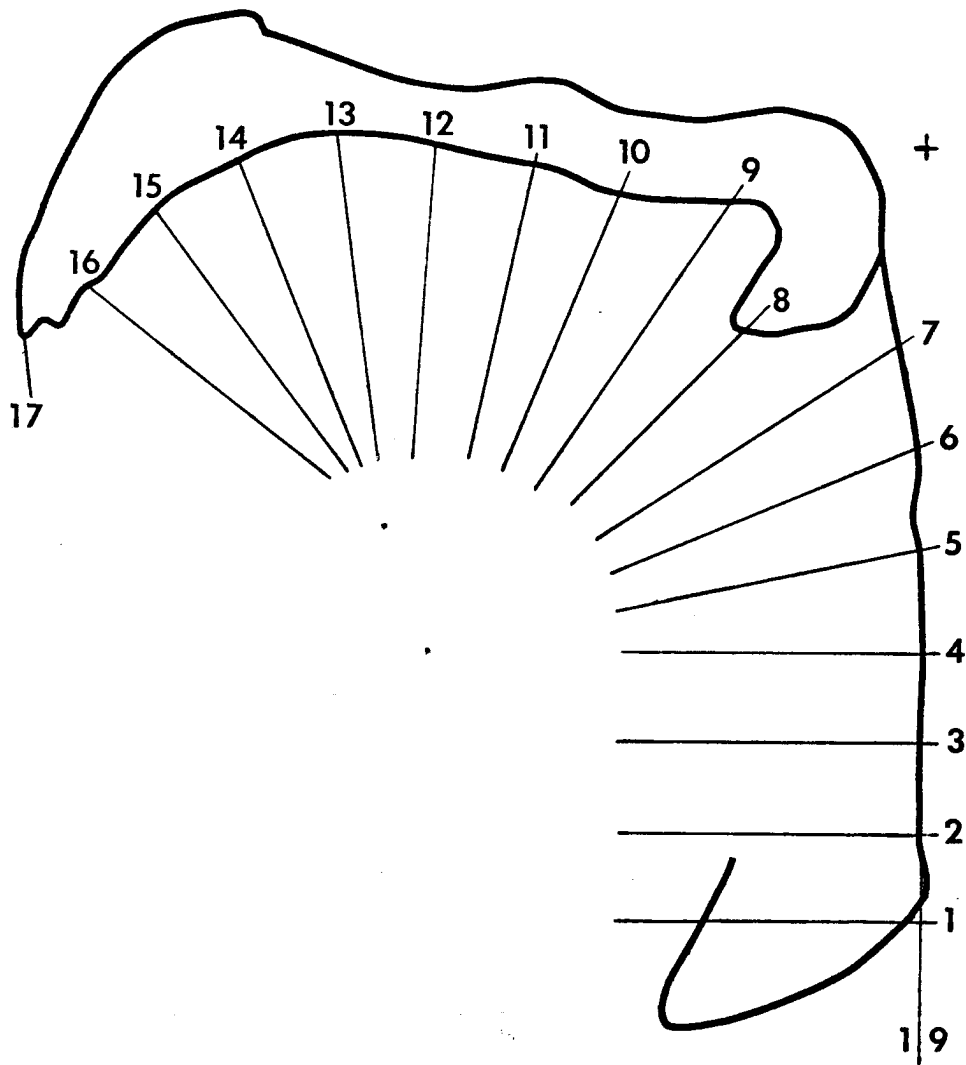

Figure 20. Radial measurement grid showing the two foci and the lines along which displacements were measured (line number 18, for distance between the lips, is not shown but is parallel to line 17).

The interlabial measurements were simply the shortest distances between the lips. The measure of larynx depth was made by drawing a tangential line from the lowest point of the pharynx outline perpendicular to and intersecting line ON. The value recorded for larynx depth was the distance between point O and this intersection. Two measures were taken at the epiglottis: one for the back surface of the epiglottis and the other for the root of the tongue anterior to the epiglottis. In the present study the former measure is used for gridlines 4 and 5 while the latter measure is used for gridline 6.

ANALYSIS OF THE DATA

A statistical analysis procedure known as PARAFAC was used on the data measured from the X-ray negatives as described earlier. See Harshman [1970, 1976] for a detailed discussion and explanation of the PARAFAC procedure and Harshman, Ladefoged, and Goldstein [1977] for a recent PARAFAC application to a description of tongue shapes for English vowels. It is not the purpose here to explain the factor analysis procedure, but only to describe how it was used in the analysis of the DhoLuo vowel data. Toward that end there will be some discussion of the PARAFAC procedure itself as well as appropriation and paraphrasing of material from the three sources mentioned above.

The input to the factor analysis consisted of a file of deviation values derived from vocal tract measurements and arranged by point of measurement for every vowel for every speaker. These values are presented in appendix III. Principally, the values of the input data set are the deviations of the tongue, measured at every gridline, for all the vowels for each speaker from a reference line. This reference line was calculated for each speaker by computing the average of the outline of the tongue for all the vowels. But also included were additional deviation values, for the distances between the teeth, between the lips, and for the depth of the larynx, similarly computed from their average distances. Thus there are nineteen measurement points of the vocal tract in this study: the sixteen gridline points, the interlabial point, the interdental point, and the point of measure of laryngeal depth. These points of measure will henceforth be referred to as *sections*. Note that these measurements (between the tongue and the surface of the passive articulators) are a function of the vocal tract shape, rather than tongue shape as in the Harshman, Ladefoged, and Goldstein study, and should not be confused with their measurements. This may explain differences in results of the two studies. The implications of these different approaches will be discussed later in chapter seven.

This PARAFAC analysis attempts to find the underlying factors of vocal tract shape. These factors specify, among other things, patterns of the shape of the vocal tract as used to distinguish the different vowels of DhoLuo. The PARAFAC procedure will find a unique set of such factors, assuming that all the speakers use the same underlying factors, though in different proportions. PARAFAC attempts to find a set of factors simultaneously for all speakers. Each factor consists of three sets of numbers. The numbers assigned to the vocal tract sections define

a particular vocal tract pattern. The numbers assigned to vowels represent the importance of that particular pattern in the configuration for that vowel. The numbers assigned to the speakers indicate the degree that each speaker uses that particular pattern.

If we define the three modes of the analysis to be vocal tract, vowel, and speaker, then, given a one-factor solution, the input (measured as deviation values for all the vocal tract/vowel/speaker intersections) is modeled as the product of the loading values for these three modes, plus a small error. As the number of factors is increased, so that there are more factors to account for the same data, we can reasonably expect a higher correlation between this model of the data and the actual data. Obviously, the more factors we use, the more we can account for of the data; if eight factors were to be used, there would be one for each vowel, for example. What we are seeking, however, is the best, or true, number of factors to account for the data.

In order to determine this number, I considered the goodness of fit for different numbers of factors extracted (or *dimensionalities*). *Goodness of fit* is not being used here in its strict technical sense, but as a term for the correlation (squared) of the PARAFAC model of the data with the actual data. A large improvement would be expected in this goodness of fit with the addition of each factor that is meaningful. The addition of nonmeaningful factors would improve the fit only a small degree. Ideally a point would be reached after which the extraction of each successive factor improved the fit by the same small amount. This point would reveal the best number of factors, given a unique solution.

Uniqueness and *ontogeny* are additional criteria used in conjunction with goodness of fit for determining the true number of factors. At each dimensionality a set of solutions is run (usually six), each one starting at a different random starting point. A set of solutions is considered to be unique if all the solutions match each other at *convergence* (this term is defined in the next paragraph). If it can be shown at a given dimensionality that there are multiple solutions, then the true number of factors is exceeded. *Ontogeny* is an informal criterion, since it can not be explicitly defined, which consists of comparing the factor loadings through successive dimensionalities. If the analysis is at a point beyond the true number of factors, we can expect to find two nearly-identical factors accounting for the same information accounted for by one factor at a lower dimensionality, or alternatively, there can be two loading columns which effectively cancel each other out mathematically, while the other columns are comparable to a solution at a lower dimensionality.

The analysis began with an arbitrary set of vocal tract, vowel, and speaker loadings which were randomly assigned by the computer. The program then improved the fit of the modeled data to the actual data in small iterative steps until an optimal solution was obtained. This point was considered to be reached when the solution had stabilized to less than a 0.1% change in the factor loadings over a span of thirty iterative steps. At this point, which is called *convergence*, I noted the factor loadings as well as the squared correlation of the model with the data. On the few occasions when, even after many iterations, an optimal solution was not reached, this fact was noted along with the correlation values.

Chapter five: Number of factors

INTRODUCTION

In this chapter and the next I will present and discuss four different analyses of the data from the viewpoint of determining the proper number of factors -- or dimensionality -- to account for the data (this chapter) and interpreting these factors in phonological or physiological terms (next chapter).

Before performing these analyses I did a preliminary factor analysis on the complete data set -- that is, using data for all eight speakers for the following five measurement areas: 1) the lower vocal tract or pharynx (sections 1-4); 2) the upper vocal tract (sections 5-16); 3) the teeth and lips (sections 17-18); 4) the depth of the larynx (measured along line 19); and 5) the acoustic information provided by measurements of the first three formant frequencies of the vowels. The values for the teeth, lips, and larynx depth were reduced by a power of 4 and the formant frequencies by a power of 7 to prevent them from distorting the relationships among the vocal tract measures of the tongue. The results of this preliminary analysis were fuzzy. It was difficult for some solutions to reach convergence with these data and there was no clear indication of the proper number of factors for them. Because the speaker loadings were erratic, with occasional loadings of opposite sign, a possible interpretation of these results was that some speakers consistently used another factor in the production of their vowels or in some other way had measurements that flattened the goodness of fit curve.

The four principal analyses that followed were restricted both with respect to the vocal tract and the number of speakers; these restrictions have yielded more interpretable results. Two of these analyses dealt with the first two measurement areas mentioned above -- the upper and lower vocal tract -- while the other two analyzed only the upper vocal tract. The purpose of this last restriction was to discover what contribution, if any, may have been made by the first measurement area: the pharynx. The last three measurement areas mentioned above will not be included in this study. With respect to number of speakers, one analysis of each type was done with six speakers and one analysis of each type was done with four speakers. This can be pictured with the following 2 x 2 matrix.

6 speakers sections 1-16	6 speakers sections 5-16
4 speakers sections 1-16	4 speakers sections 5-16

The one speaker with an incomplete set of X-rays and another speaker whom we were unable to record had their data eliminated from the data set in order to achieve a more reliable six-subject data base. (Missing values had been supplied for these subjects by averaging and interpolation.) When our results were still unclear, we further reduced the subject population by two speakers who each exhibited negative speaker loadings on two occasions (at the 3-factor and the 4-factor degrees of dimensionality). These were clear instances of speakers using factors differently.

Each analysis consisted of a set of solutions (usually six) which were run to convergence, or to a point where a solution localized and would not converge. The values of the correlations (r^2) at these points were noted and used as a measure of the goodness of fit between the actual data and the solutions as modeled by the program. By plotting a graph of the goodness of fit (that is, the r^2 values) we should be able to discern the true, or best, number of factors that account for the data.

In the hypothetical curve below, for example, we would conclude that there are not more than four real factors, since above this number the increase in the value of r^2 is a small steady increment indicative of the improvement resulting only from the extraction of a larger number of factors (see Harshman, Ladefoged, and Goldstein [1977]).

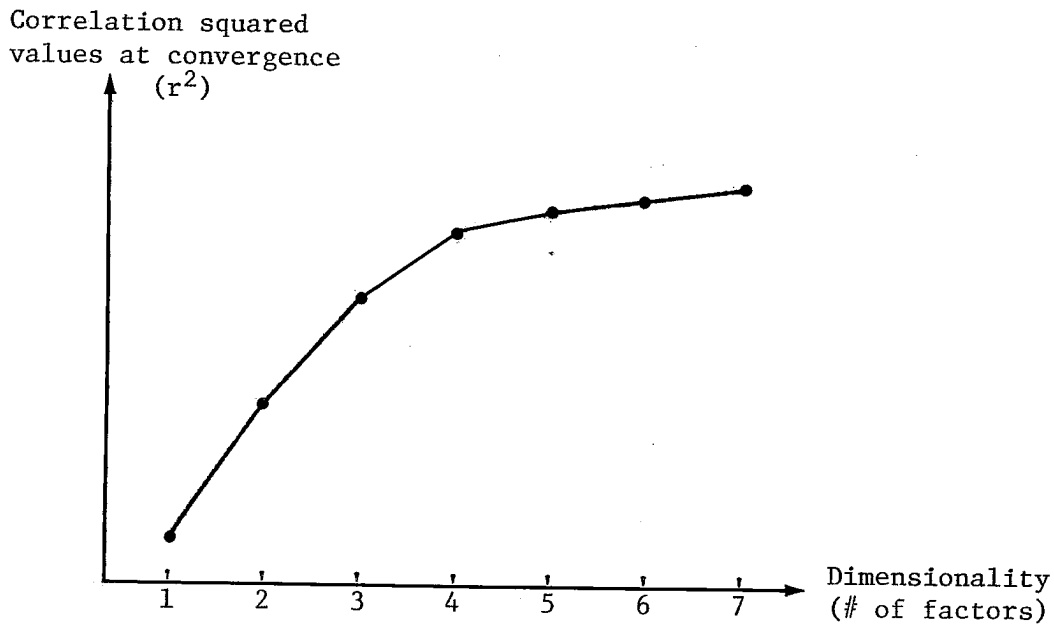

In this curve there is a clear bend at 4 factors. This indicates that there should be four major systematic components in the data. These components should be interpretable from the factor loadings. If there is not a clear bend in the r^2 curve, this could result from any of the following three sources: 1) a lot of small influences, 2) data which are not well-suited for the factor analysis, or 3) a high noise level. Noise can be defined as random or unsystematic deviations of the measurements from their true underlying targets -- such deviations as those caused by measurement errors, subject sloppiness, image foreshortening, and so forth.

SIXTEEN-SECTION ANALYSES

For these analyses only sections 1-16 were considered, comprising both the upper and lower vocal tract, but excluding the teeth, lips, and measure of larynx depth.

1. Six-subject analysis. For this analysis the subject population was reduced to six, as mentioned in the first paragraph on page 48. For the first 5 degrees of dimensionality six solutions were performed from random starting points. The r^2 values given are the highest figure attained for the solutions being discussed. If two solutions are correspondingly similar or identical in their values and directions, they are said to match each other or to be matching solutions.

1-factor solutions: All six solutions converged ($r^2=0.6238$) and all solutions have loading patterns that match each other.

2-factor solutions: All six solutions converged ($r^2=0.7396$). All of the solutions have matching vowel loadings, though two of the solutions differ inexplicably from the other four in terms of the speaker and vocal tract loadings. The six solutions are accepted as similar, in spite of this discrepancy.

3-factor solutions: Four solutions converged ($r^2=0.8246$) and have matching loadings after 420 iterations. The remaining two solutions matched the first four but did not converge after more than 1600 iterations ($r^2=0.8211$).

4-factor solutions: Five solutions converged ($r^2=0.8787$) and have matching vowel loadings. Two of these match for all loadings and converged early (640 and 800 iterations) while the remaining three match each other, having converged after 1000 to 1500 iterations but with slightly better fits than the other two. The remaining solution does not match any of the others and failed to converge after more than 2000 iterations when its goodness of fit had reached an r^2 value of 0.8757.

5-factor solutions: At this dimension there are multiple solutions, none of which reached our criterion for convergence. There are three matching solutions after 200-390 iterations at the best goodness of fit ($r^2=0.9034$), two matching solutions at 740 iterations with a slightly poorer fit ($r^2=0.9018$). The nonuniqueness of the solutions at five factors tells us that this number of factors exceeds the true number. Nonetheless, several solutions at higher dimensionalities were run in order to get values for the correlation of the modeled solution to the actual data. This provides us with the amount of improvement that can be achieved simply by the addition of another factor to account for the same data.

6-factor solution: One solution was run to convergence after 640 iterations ($r^2=0.9218$).

7-factor solutions: Two solutions were run for 160 iterations after which a squared correlation value of 0.9405 was achieved.

The goodness of fit curve for these solutions is presented in figure 21. The ordinate indicates the squared correlation (r^2) values, which are also presented as numerical values directly below the respective dimensionality numbers on the abscissa. On the line below these r^2 values the differences between the values at adjacent dimensionalities are presented. These serve as useful indicators of the amount of improvement achieved between successive numbers of factors.

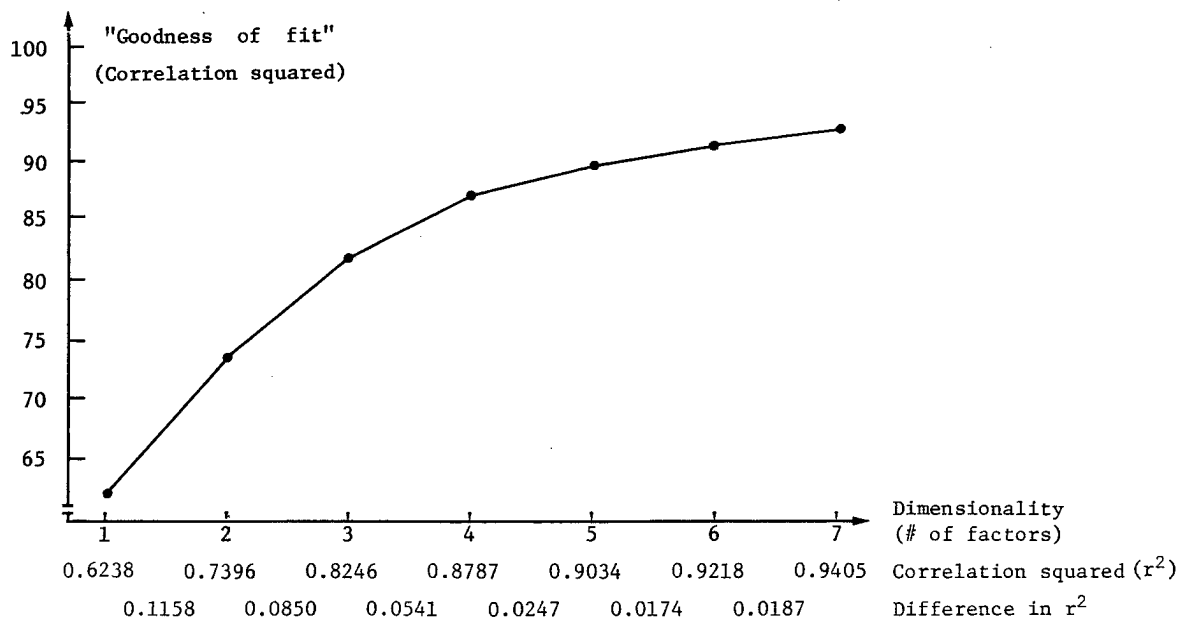

Figure 21. Goodness of fit curve: 6 subjects, 16 sections.

In looking at this curve we note that after four factors it tends to become a gradual straight-line slope that indicates the improvement yielded from the extraction of additional factors. However, there is no distinct bend in this curve to indicate where substantive improvements leave off and improvements which result from the use of more factors remain. One could argue that this point is at either three or four factors. We know that five factors is too many, because of a multiple nonunique set of solutions at that dimensionality. Selecting four factors looks inviting because of the severe drop in improvement between 3 and 4 factors and 4 and 5 factors; yet, there is no distinct bend.

It could be the case that four factors are too many, or even that three are. To determine this, we must consider the criterion of ontogeny; that is, we must check the solutions at different dimensionalities against each other to see if some *real* factor might not be represented as two *false* factors which are complementary subtotals of the real factor. This type of comparison will be made in the next chapter.

Another approach would be to reduce the number of speakers further to see if this might not produce clearer results. This approach was tried here, with the reduction of the number of speakers to four.

2. Four-subject analysis. This analysis was done on the same data but with that of the two most divergent speakers of the six-subject analysis eliminated. These speakers were judged to be divergent by comparing their speaker loadings with those of the other speakers. In the four-factor solution, for example, these two speakers had speaker loadings which were opposite in sign from the other four speakers for one of the factors. For that factor of the solution, which hopefully would be correlated to a physiological or articulatory parameter, these two divergent speakers were behaving in a contrary manner to all the others.

The analysis was performed on the four "consistent" speakers, as in the preceding section. Six solutions were run from random starting points for 1, 2, and 3 factors; seven solutions were run for 4 factors; for 5 factors there were five solutions run; while only one solution a-piece was done at 6 and 7 factors. These solutions are now discussed.

1-factor solutions: All six solutions converged ($r^2=0.6979$) and all solutions have loading patterns that match each other.

2-factor solutions: All six solutions converged ($r^2=0.8169$) and all solutions match each other.

3-factor solutions: Five solutions which have matching loading patterns converged ($r^2=0.8827$). One nonmatching solution failed to converge after 1100 iterations ($r^2=0.8826$). The vowel loadings for this solution are stable, but the speaker and tract loadings are trading off against each other (as one increases, the other decreases in value). This solution was unable to reach convergence for this reason.

4-factor solutions: Multiple nonmatching solutions resulted at this dimensionality. There were three matching solutions where two of the factors converged, but where the other two traded off ($r^2=0.90766$). However, there is one solution with a slightly higher squared correlation ($r^2=0.90767$) which had not converged after 1700 iterations. The remaining three solutions are all uniquely nonmatching, have failed to converge after many iterations (1420-1700), and have poorer fits than the first four mentioned solutions ($0.9052 < r^2 < 0.9066$).

I conclude from this that four factors are more than the real number of factors to account for the data. In order to determine the improvement in fit from merely increasing the number of factors, some solutions were done at higher dimensionalities, however.

5-factor solutions: Four solutions matched but did not converge after 1400 iterations ($r^2=0.9289$); additionally, there was one nonmatching solution stuck at a local optimum ($r^2=0.9276$).

6-factor solution: One solution was iterated until the r^2 value failed to improve substantially with continued iterations ($r^2=0.9446$).

7-factor solution: One solution was iterated until the correlation squared failed to improve substantially with continued iterations. This was at an r^2 value of 0.9625.

The curve showing the r^2 values for different numbers of factors for these four speakers is shown in figure 22 as a solid line. For purposes of comparison, the goodness of fit curve for the comparable six-subject analysis is included on this graph as a broken line. The numerical values below the abscissa refer to the four-subject analysis. As in figure 21, these numbers are the respective r^2 values at each dimensionality, with the differences between each successive pair of values appearing on the line below.

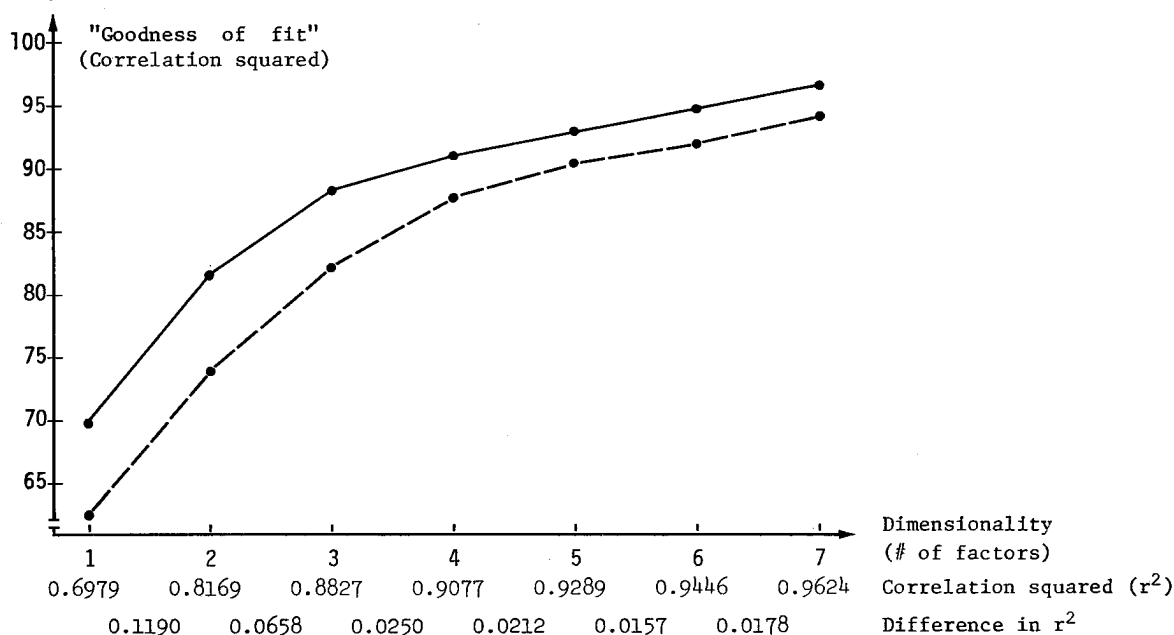

Figure 22. Goodness of fit curve: 4 subjects, 16 sections. The broken line represents the six-subject analysis curve (cf. figure 21).

We see here that with fewer, but more uniform, speakers we get a better goodness of fit. What is more striking is that now there is a distinct bend in the curve at 3 factors. After this point the gentleness of the slope suggests only the steady increment in fit that we expect with the use of additional factors fitting the noise (and no substantive improvement). Having a nonunique solution at 4 factors substantiates that there cannot be more than three factors for this analysis.

In the next chapter we shall attempt to interpret these three factors in articulatory or physiological terms, since, on the basis of the goodness of fit curve alone, there is reason to believe that these are true and substantive factors. It remains to be explained why there is no clear bend in the r^2 curve for the six-subject analysis. A comparison of the curves for the two analyses (see figure 22) shows that they are basically parallel to each other, except that the fit at 3 factors has been suppressed for the six-subject analysis.

This should not surprise us when we recall that the difference between these analyses is that two speakers with an aberrant speaker loading in the three-factor six-subject solution were eliminated to create the data set for the four-subject analysis. It suggests that the contrary behavior of these two subjects may have suppressed the fit at 3 factors and deprived the fit curve of a clear bend. It also raises the question: if two speakers out of six use one vowel production parameter in an opposite way to the other speakers, how do they maintain the phonological distinctions between the vowels? This interesting and important question will be raised again in the final chapter, at which time we shall be better able to discuss it.

TWELVE-SECTION ANALYSES

The following two analyses were made with the data set reduced to eliminate the area of the pharynx (sections 1-4). My hypothesis was that if one of the factors was physiologically correlated to pharyngeal activity, as we might reasonably expect from the discussion on page 6, then an analysis restricted to the upper vocal tract would extract one less substantive factor than an analysis of all sixteen vocal tract sections. If this hypothesis is supported, we would predict multiple, nonunique, solutions at 3 factors or beyond and a distinct bend in the r^2 curve at 2 factors.

The results of these two analyses are sketched below; one analysis is of the six-subject population and the other is of the four-subject population. Since it had already been determined that there can be no more than four substantive factors, just a few solutions were run beyond this dimensionality and only to determine the goodness of fit.

1. Six-subject analysis. This analysis is parallel to the one conducted for sixteen sections and the six subjects are identical.

1-factor solutions: All solutions match and converge ($r^2=0.6965$).

2-factor solutions: All solutions match and converge ($r^2=0.8032$).

3-factor solutions: The six solutions here apparently form three matching pairs of solutions -- with a small range in their correlation squared values ($0.8686 \leq r^2 \leq 0.8696$).

4-factor solutions: All six solutions converged and match each other ($r^2=0.9312$).

5-factor solutions: Two matching solutions were run until their correlation squared values stabilized ($r^2=0.9495$).

6-factor solutions: Two nonmatching solutions were run to yield a goodness of fit of $r^2=0.9629$.

7-factor solutions: Two similar, but nonmatching, solutions were run to yield a goodness of fit of $r^2=0.9718$.

In figure 23, the goodness of fit curve is displayed for this analysis, along with the r^2 values and difference in r^2 values between adjacent dimensionalities. The goodness of fit curve for the 16-section analysis is included as a broken line for the purposes of comparison.

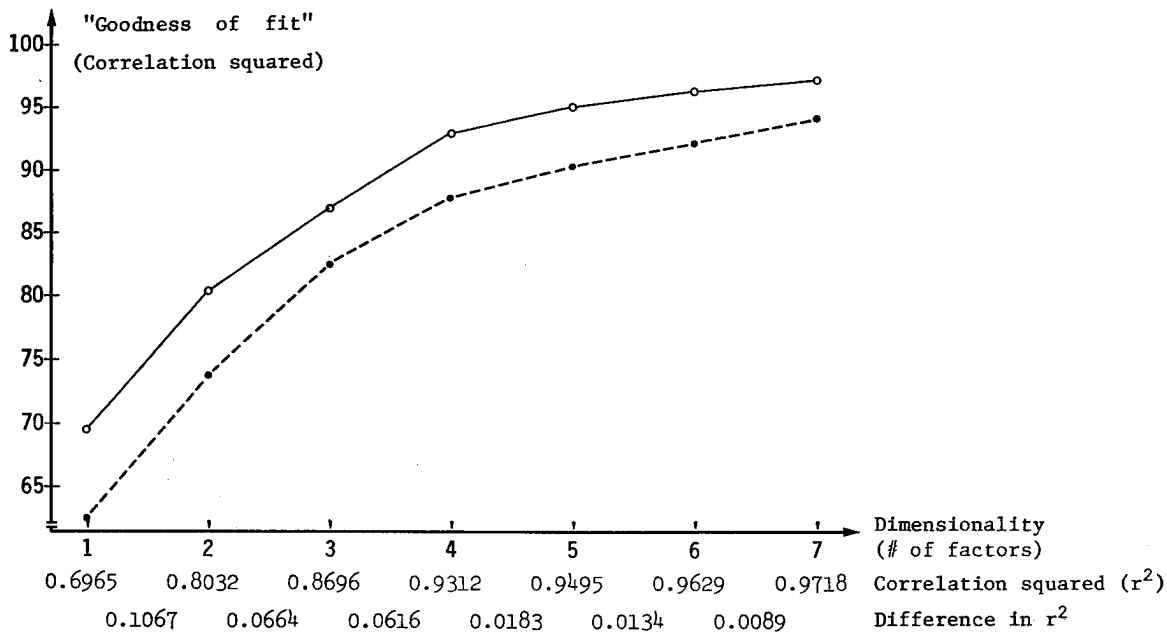

Figure 23. Goodness of fit curve: 6 subjects, 12 sections. The broken line represents the sixteen-section analysis curve (cf. figure 21).

The goodness of fit curve for the twelve-section solution is very similar to the curve for the sixteen-section solution. It has a better fit, of course, because there is less data to be accounted for. Like the sixteen-section solution, it has no clear bend, though where it has a tendency towards one, at 2 factors and 4 factors, it can be argued that this is rather a suppression of the fit at 3 factors. This will be supported when we compare the two twelve-section curves (see figure 24).

The hypothesis that I advanced at the beginning of this section is clearly not supported.

2. Four-subject analysis. This analysis is parallel to the one conducted for sixteen sections and the four subjects are identical.

1-factor solutions: All solutions match and converge ($r^2=0.7694$).

2-factor solutions: All solutions match and converge ($r^2=0.8681$).

3-factor solutions: After 890 iterations only one factor achieves convergence. The other two factors seem to "rotate" around each other: as one increases in value, the other will decrease proportionally. The highest squared correlation value reached was $r^2=0.9309$.

4-factor solutions: Four solutions were run at this dimensionality reaching a goodness of fit of $r^2=0.9481$.

5-factor solutions: Three solutions were done, but failed to converge and do not appear to match after 1000 iterations. The goodness of fit achieved was $r^2=0.9607$.

6-factor solutions: Two solutions were done reaching an r^2 value of 0.9747.

7-factor solution: The one solution done at 7 factors achieved an r^2 value of 0.9828.

The goodness of fit curve for these solutions is presented below in figure 24, where it is compared with the same analysis done with six speakers. This upper vocal tract analysis (12 sections) is similar to the sixteen-section analysis in that the goodness of fit curves for the six-subject solutions have a bend in the curve at 4 factors while the curves for the four-subject solutions have a bend at 3 factors (cf. figure 22). This argues for a differential use of the factors by the speakers and shows that if there is a separate factor for pharyngeal activity it is not confined to the pharyngeal area but manifests itself elsewhere within the vocal tract.

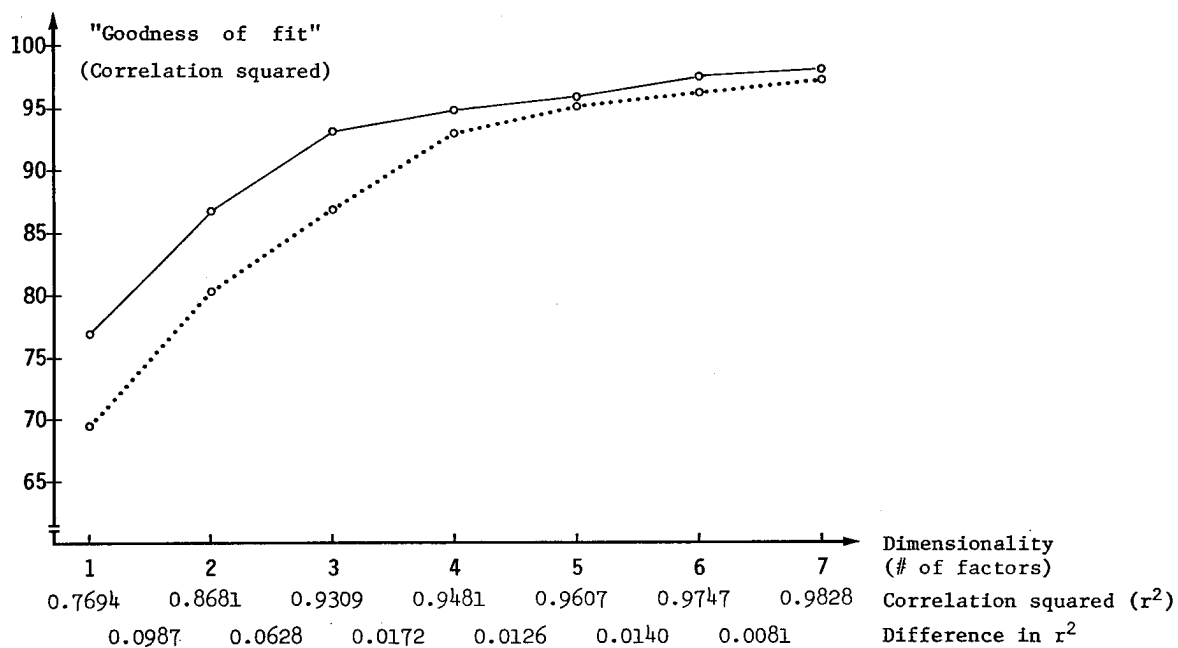

Figure 24. Goodness of fit curve: 4 subjects, 12 sections. The dotted line represents the comparable six-subject analysis curve.

The four goodness of fit curves for these analyses are presented together in figure 25. It should be clear from this graph that the four-subject analyses have better fits than their six-subject counterparts and that there is a clear bend at 3 factors for them (these four-subject curves are presented as solid lines). It should also be evident from this figure that there are no substantive factors beyond the 4 factor dimension.

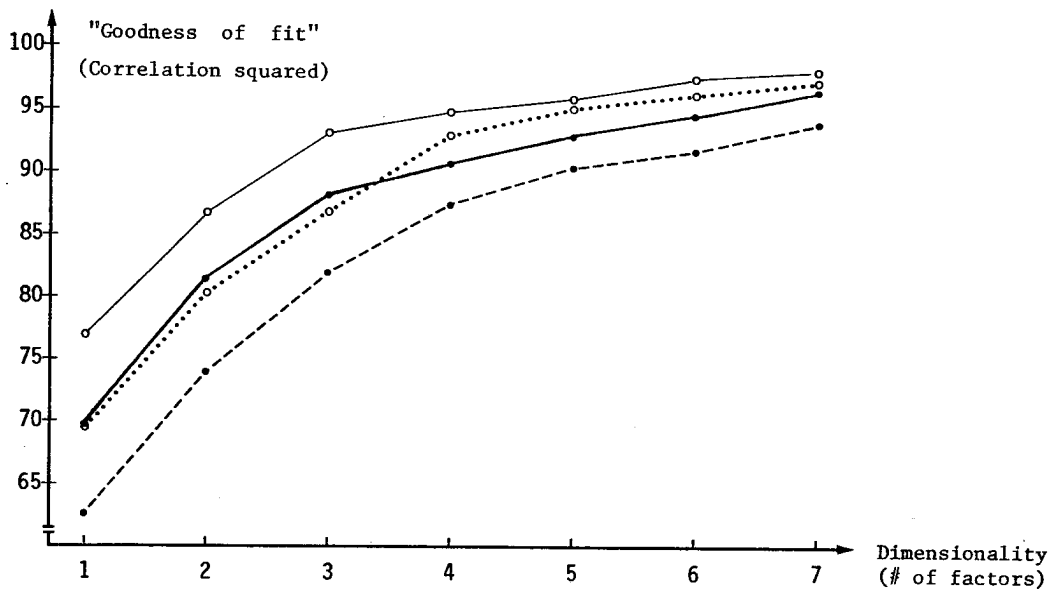

Figure 25. Goodness of fit curve: the four analyses compared. Solid lines represent four-subject analyses; broken or dotted lines represent six-subject analyses. The twelve-section analyses (upper vocal tract only) are shown with circles while the sixteen-section analyses are shown with dots (cf. figures 21-24).

MEAN SQUARE ERROR

It might be useful to look at the difference in the mean square error values between adjacent dimensionalities as well as the difference in the correlation squared values between adjacent dimensionalities. The latter figures have already been presented as a part of the goodness of fit figures (figures 21-24) but will be tabulated here so that the values for all the analyses can be viewed together. These values do not normally provide us with any new information since they are mathematically related to the correlation values (only in the case of having one or two isolated points of disproportionately high value can we expect the mean square error not to have an inverse relationship to the correlation squared). They are included here, though, because they do provide another perspective for deciding at what dimensionality there are no further substantive factors extracted by the analysis.

Table 3. Difference in mean square error values between adjacent dimensionalities. The zero dimension is the variance of the data.

Analysis	Dimensionality						
	0-1	1-2	2-3	3-4	4-5	5-6	6-7
6'16"	0.1445	0.0268	0.0197	0.0125	0.0057	0.0054	0.0043
6'12"	0.1809	0.0277	0.0173	0.0160	0.0048	0.0034	0.0022
4'16"	0.1667	0.0284	0.0157	0.0060	0.0048	0.0041	0.0043
4'12"	0.2007	0.0257	0.0164	0.0045	0.0033	0.0036	0.0021

Table 4. Difference in correlation squared values (r^2) between adjacent dimensionalities.

Analysis	Dimensionality					
	1-2	2-3	3-4	4-5	5-6	6-7
6'16"	0.1158	0.0850	0.0541	0.0247	0.0184	0.0187
6'12"	0.1067	0.0664	0.0616	0.0183	0.0134	0.0089
4'16"	0.1190	0.0658	0.0250	0.0212	0.0157	0.0179
4'12"	0.0987	0.0628	0.0172	0.0126	0.0140	0.0081

These two tables clearly show the differences between the analyses with six subjects and those with four. A line has been put into the tables to separate the substantive from nonsubstantive differences.

CONCLUSIONS

Assuming that the solutions discussed in this chapter are in fact valid solutions that truly model the data, the following conclusions can be drawn based on the values for goodness of fit (defined as the squared correlation values) of the modeled data to the actual data at different degrees of dimensionality (number of factors extracted by the analysis) and on values for mean square error of the solutions:

1. My hypothesis suggesting that a smaller number of factors can account for the upper vocal tract than for the entire vocal tract is not supported.

2. There cannot be more than four true factors for any of the six-subject analyses nor more than three true factors for any of the four-subject analyses of our data set.

3. There is a better "fit" and a smaller number of factors is indicated for the analyses with the four "most reliable" speakers than for the larger "noisier" analyses with six speakers.

4. This suggests that what was selected against by weeding out "divergent" speakers was the use of an additional factor.

5. This also suggests variability in the use of the factors so that an analysis of speakers at large could easily obscure the contributions of individual factors.

Chapter six: Interpretation of factors

INTRODUCTION

We saw in the last chapter how well our modeled solutions fit the data with the extraction of a different number of factors. With a speaker population of four, no more than three real factors could be extracted. It appears then that there may be as many as four different factors used in the production of DhoLuo vowels, but that different speakers use different factors or use the factors to different extents. The extraction of an extra factor was required with six speakers to resolve these idiosyncracies.

All of the factors have been devoid of meaning in the discussion so far. In this chapter we will try to provide them with meaning by interpreting them in articulatory or physiological terms, and, where possible, relating these to phonological distinctions. We will do this by discussing the sixteen-section analyses rather thoroughly. Little was gained by the elimination of the pharyngeal measures in the twelve-section analyses except for being able to note the suppression of an otherwise clear bend in the curve (this, of course, indicates a contribution from the pharyngeal area in the three-factor solution) -- the better goodness of fit achieved by this solution could be expected from having a smaller body of data accounted for by the same number of factors. Assume then that what interpretations and claims are made for the sixteen-section analysis hold also for the corresponding twelve-section analysis, unless special mention is made to the contrary.

I will present facsimiles of actual factor loadings for the solutions under discussion, as well as analogical representations for them. These representations provide a very straightforward way to understand the significance of the loadings. Hopefully, they will make it easy to see the complementary gestures that are involved in vowel production in DhoLuo. For the three modes in the tables, Mode A is for the speaker loadings, Mode B for the vowel loadings, and Mode C for the vocal tract loadings. The numbers in Mode B represent the vowels as follows: 1= i, 2= ɪ, 3= e, 4= ε, 5= o, 6= ɔ, 7= u, and 8= ω. Odd numbers are for vowels of one harmony category (the "close, breathy" set) and even numbers represent vowels of the other harmony category (the "open, creaky" set). The numbers in Mode C correspond to the sections of the measurement grid developed in chapter 4 (see figure 20, page 44). In the analogical representations, the speaker and vowel loadings are presented as displacements from zero along a line; the vocal tract tracings are presented on a midsagittal cross section display and, in some cases have been rescaled to fit into the display. Where this has been done the coefficient of rescaling is noted on the graph. In appendix IV a complete set of representative factor loadings up to four factors is available for inspection.

SIX-SUBJECT SOLUTION

The solution to be discussed first is at four factors. We determined in the previous chapter that this is the largest number of factors that can be considered to account for the data for two reasons. The first is that beyond this point there is no meaningful improvement in the correlation of the modeled data to the actual data. Secondly, we get an obviously nonunique solution at five factors.

It also appears, at first glance, that the four-factor solution is nonunique, but this is not obvious and warrants careful inspection -- especially since a fourth factor contributes meaningfully to the goodness of fit curve. Recall that two solutions converged early (within 800 iterations) and match completely. Another three solutions took twice as long to converge and match each other, but only match the first two solutions with respect to the vowel loadings. The lone remaining solution did not converge (after 1480 iterations) and doesn't match any of the others. Let us look first at this aberrant solution, which is presented in table 5.

The striking thing that one notes here is the similarity between the two outside columns. The only major difference is in the sign of Mode C. Is this really a three-factor solution masquerading as a four-factor solution, but with one factor split and presented as two columns? If we compare it to the three-factor solution (cf. table 8), it is clear that these solutions at different dimensionalities do not agree with each other; that is, the two inside columns of the four-factor solution -- the nonsuspicious ones -- do not agree with any two of the columns of the three-factor solution. Could it be a two-factor solution, then? This seems a likelihood; since there is complementary polarity for Mode C of the two similarly patterned columns, the product of all three modes for one factor will essentially cancel out the product of the other factor. The remaining two columns, however, do not look like likely candidates for the factors of a two-factor solution: one of them has [u] agreeing with [i], [ɪ], and [e], while for the other column [ɔ] is agreeing with these. For both of them [u] and [ɔ] are very far apart spatially. Whatever these two columns are accounting for does not seem to have much basis in reality. We can only conclude from this that if this aberrant solution is a four-factor solution it somehow got hung up at a local optimum and will not converge or reach agreement with the other solutions at this dimensionality. In support of this conclusion is the observation that the r^2 value of this aberrant solution is considerably lower than those of the other four-factor solutions. Whether this solution is a real four-factor solution or not, it can clearly be dismissed from consideration.

Table 5. Factor loadings: Four-factor aberrant solution. Correlation squared= 0.8756670 (converged @ 2000 iterations).

MODE A: SPEAKERS

1	1.394	0.2435	0.3467	1.373
2	1.071	0.5281	1.264	1.090
3	1.023	-0.5836	0.1703	0.9766
4	0.7734E-01	-2.203	0.6007	0.2479
5	1.178	0.4463	1.596	1.181
6	0.6851	0.5173	1.159	0.7185

MODE B: VOWELS

1 [i]	0.6449	1.281	1.805	0.4319
2 [ɪ]	1.401	1.295	0.7130	1.319
3 [e]	0.7393	0.3300	0.2873	0.6529
4 [ɛ]	0.9644	-0.2731E-01	-0.4949	1.059
5 [o]	-0.7895	-1.408	-0.6536	-0.6900
6 [ɔ]	-0.5863	-1.193	-1.452	-0.1977
7 [u]	-1.611	-0.8895	0.7191	-1.876
8 [ɔ̃]	-0.7639	0.6123	-0.9249	-0.7003

MODE C: VOCAL TRACT SECTIONS

1	-0.7797	0.6653E-01	0.2212	0.5792
2	-0.1670	-0.1011E-01	0.1898	0.9377E-02
3	0.4869	-0.4124E-01	0.2031	-0.6048
4	0.8958	-0.1333	0.2452	-1.077
5	0.7943	-0.2551	-0.4808	-0.8608
6	0.3841	-0.2508	0.5053	-0.3897
7	-0.1304	-0.2105	-0.5137	0.1786
8	-0.1017	-0.2074	0.4225	0.1473
9	-0.5044	-0.1632	0.2792	0.5872
10	-1.356	-0.5012E-01	0.2418	1.383
11	-1.819	0.8970E-01	0.1160	1.760
12	-2.090	0.1973	0.1480E-01	1.946
13	-2.190	0.2275	-0.7231E-01	1.918
14	-1.953	-0.2247	-0.1308	1.621
15	-1.543	0.1983	-0.1734	1.211
16	-1.278	0.1849	-0.1630	0.9326

Let us look now at the four-factor loadings for the two sets of solutions which reached convergence. Tables 6 and 7 give a representative solution from each of the two internally matching sets. Since the order of the columns and the polarity of any two of the modes is arbitrary -- all that matters is that the sign of the triple product is maintained -- these may have been altered to maximize the similarity between these two solutions. Note that Mode B is identical for both of these sets as it is for all five of these four-factor solutions.

Table 6. Factor loadings: A converged four-factor solution. Correlation squared= 0.8787369 (@560 iterations).

MODE A: SPEAKERS

1	0.3341	0.3726E-01	0.1219	0.2636
2	0.2146	0.2156	0.2321	0.2045
3	0.3714	0.1490	-0.5466E-01	0.2855
4	0.1302	0.4843	-0.1814	0.3313
5	0.2931	0.3636	0.1811	0.2522
6	0.1160	0.2106	0.1659	0.1527

MODE B: VOWELS

1 [i]	0.5522	1.804	0.9523	1.057
2 [ɪ]	1.309	0.9673	-0.2888	0.2989E-03
3 [e]	0.8625	0.3061	0.2265	-0.1271
4 [ɛ]	1.115	-0.5748	-0.2428	-1.128
5 [o]	-0.7466	-0.8559	0.1794	-0.3834
6 [ɔ]	-0.6868	-1.519	-0.9065	-1.591
7 [u]	-1.393	0.3455	1.778	1.612
8 [ɑ]	-1.012	-0.4742	-1.699	0.5635

MODE C: VOCAL TRACT SECTIONS

1	-0.8771	0.6351	0.6478	-0.5200
2	-0.5098	0.4030	0.9746	-0.3497E-01
3	-0.1369	0.2825	1.036	0.6382
4	-0.1930	0.3553	1.714	0.9095
5	0.4189E-01	1.446	1.675	0.6158
6	0.4166E-01	1.702	1.426	0.1924
7	0.1380E-01	1.875	1.013	-0.2654
8	0.1059	1.568	0.9577	-0.2928
9	-0.6676E-02	1.275	0.3286	-0.6523
10	-0.5099	1.256	0.8152E-01	-1.376
11	-0.9239	0.7952	-0.3600	-1.619
12	-1.278	0.3935	-0.6600	-1.703
13	-1.759	0.1494	-0.9246	-1.650
14	-1.872	-0.9848E-01	-0.9463	-1.367
15	-1.701	-0.3228	-0.9248	-0.9747
16	-1.632	-0.3717	-0.7419	-0.7360

On scrutinizing these solutions one finds that as different as the Mode A and Mode C loadings are, the quantitative order is constant from the loadings of one column to the loadings of the respective column of the other solution. For example, the speaker loadings for the first factor are ranked 3, 1, 5, 2, 4, 6 for both of these solutions. It is

Table 7. Factor loadings: Another converged four-factor solution.
 Correlation squared= 0.8787376 (@ 860 iterations).

MODE A: SPEAKERS

1	1.275	0.1316	0.7352	1.035
2	0.8191	0.7612	1.400	0.8026
3	1.417	0.5216	-0.3297	1.121
4	0.4969	1.710	-1.094	1.300
5	1.119	1.284	1.092	0.9898
6	0.4426	0.7436	1.001	0.5994

MODE B: VOWELS

1 [i]	0.5522	1.804	0.9523	1.057
2 [ɪ]	1.309	0.9673	-0.2888	0.3021E-03
3 [e]	0.8625	0.3061	0.2265	-0.1271
4 [ɛ]	1.115	-0.5748	-0.2428	-1.128
5 [o]	-0.7466	-0.8559	0.1794	-0.3834
6 [ɔ]	-0.6868	-1.519	-0.9065	-1.591
7 [u]	-1.393	0.3455	1.778	1.612
8 [ʊ]	-1.012	-0.4742	-1.699	0.5635

MODE C: VOCAL TRACT SECTIONS

1	-0.2298	0.1798	0.1074	-0.1325
2	-0.1336	0.1141	0.1616	-0.8910E-02
3	-0.3588E-01	0.7999E-01	0.1717	0.1626
4	-0.5056E-01	0.1006	0.2841	0.2317
5	0.1098E-01	0.4096	0.2778	0.1569
6	0.1092E-01	0.4821	0.2364	0.4903E-01
7	0.8622E-02	0.5310	0.1680	-0.6738E-01
8	0.2776E-01	0.4439	0.1588	-0.7458E-01
9	-0.1746E-02	0.3609	0.5448E-01	-0.1662
10	-0.1336	0.3557	0.1352E-01	-0.3505
11	-0.2421	0.2252	-0.5969E-01	-0.4125
12	-0.3349	0.1114	-0.1094	-0.4338
13	-0.4608	0.4230E-01	-0.1533	-0.4205
14	-0.4904	-0.2788E-01	-0.1569	-0.3482
15	-0.4458	-0.9140E-01	-0.1533	-0.2483
16	-0.4275	-0.1053	-0.1230	-0.1875

similarly true for all of the loadings that their rank orders are constant with those of their counterpart columns in the other solutions. These solutions agree with respect to their r^2 values to five decimal places. It seems that all five of these solutions are making the same account of the data, but that some of them vary by a multiplicative coefficient (whose presence I cannot explain).

In some special sense then, all five of these converged solutions are the same. We can claim for all intents and purposes that we have a four-factor unique solution. Having determined this, let us now look at figure 26 to see the analogical representations of these four factors.

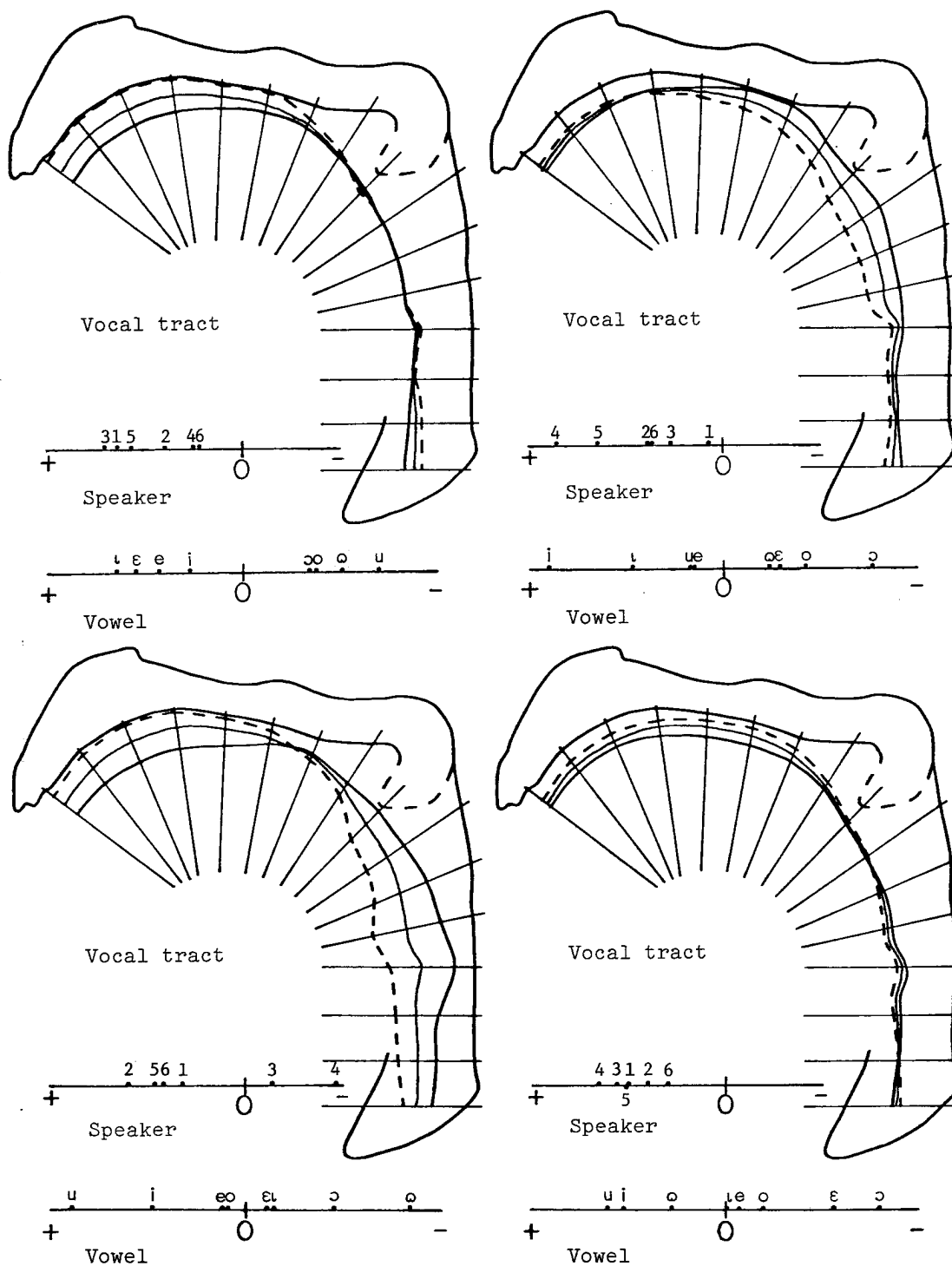

Figure 26. Analogical representation of a unique four-factor solution (six speakers, sixteen sections). Compare with tables 6 and 7.

The vowel loadings for the first factor (counting the factors left to right, top; then left to right, bottom) very decisively separate the front vowels from the back vowels: all of the front vowels are oppositely signed from all of the back vowels and the distance between the two nearest opposing vowels in this respect, [i] and [ɔ], is greater than the distance between any two vowels of like sign. No other phonological claim can be made for this factor. Most of the activity for this component is with the front of the tongue. Let us label this factor FRONT/BACK.

The second factor is not quite so clear. The major activity of the tongue is in the region of the soft palate and upper pharynx. The vowel loadings seem to indicate something like what is traditionally called vowel height, but note that there is also a pairwise distinction in harmony class and a front/back distinction within the height moieties.

The third factor shows considerable activity in the pharynx as well as somewhat less activity of the front of the tongue. The vowel loadings have all the "breathy" vowels distinct from all the "creaky" ones. It doesn't appear that any other phonological claim can be made for this factor, but note how extremely this factor separates the high back vowels, [u] and [ɔ]. Let us call this factor TONGUE ROOT.

Also note that for this factor there are two speakers, 3 and 4, who behave in a way contradictory to the other four. As was evident from the data in chapter 3 (pages 33 and 36), these two speakers differ from the others in the relative pharynx width for the high vowels. (These same speakers are divergent in the three-factor solutions also, but each one for a different factor). On the basis of this contradictory behavior, these two speakers were the ones eliminated from the data set when it was reduced to the four most "reliable" speakers.

The last factor has some activity above and below the epiglottal area, but mostly has activity in the palatal area. The vowel loadings indicate a height distinction. Both this factor and the second distinguish for height and maintain a pairwise distinction for harmony class. We can only determine this by the vowel loadings and would be hard pressed to discern this from the vocal tract displacements.

It is instructive to plot each one of these vowel loadings against every other one. This is accomplished overleaf, in figure 27.

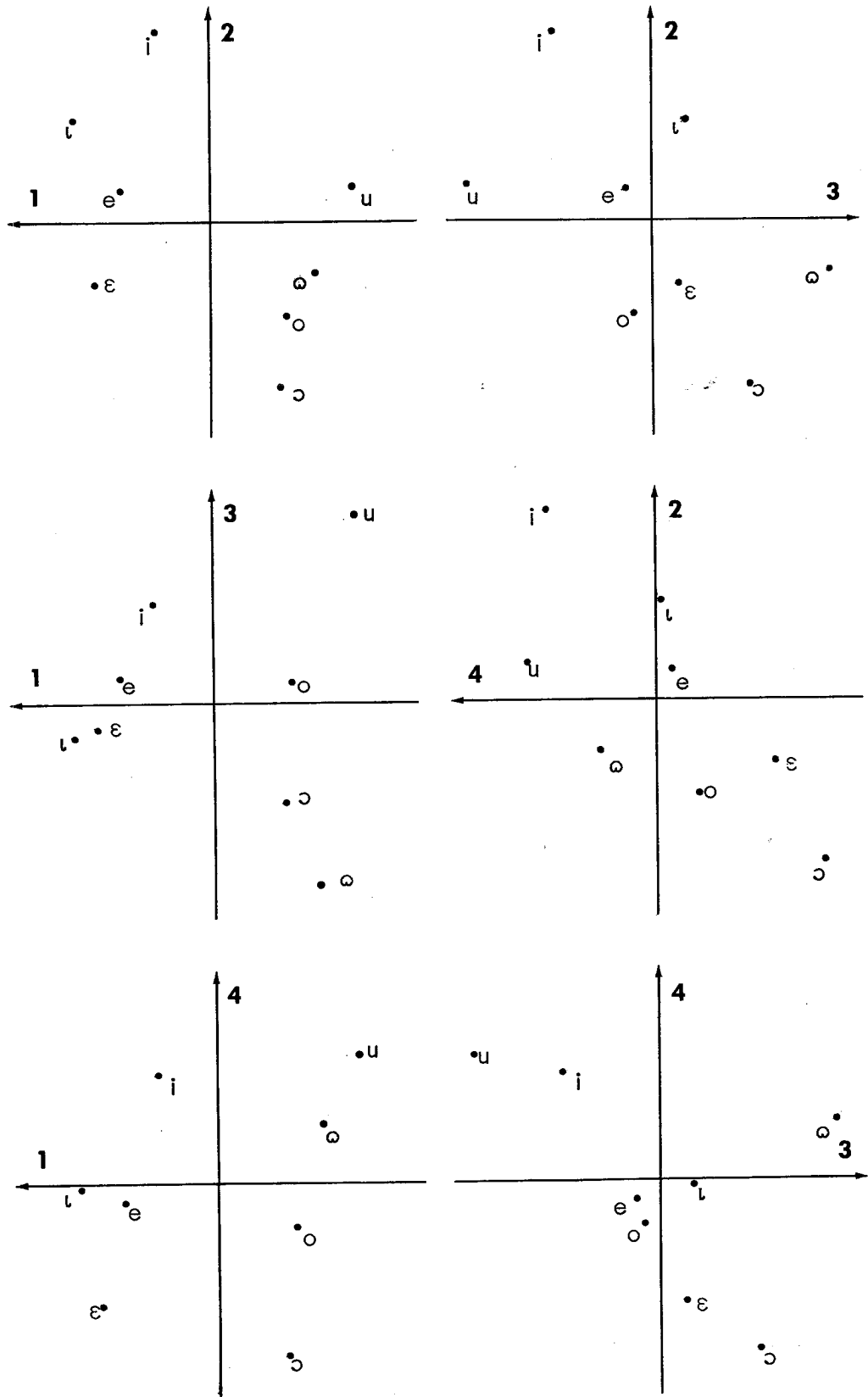

Figure 27. Vowel loading graphs (4 factors, 6 speakers, 16 sections)

In looking at these graphs we note that the 1 vs. 4 plot provides us with a more traditional distribution of the vowels than the 1 vs. 2 plot. The 1 vs. 2 plot has the back vowels lower than we expect them to be in relation to the front vowels from a traditional phonological view. However, this plot gives a better picture in articulatory terms (for examples of this in Ngwe see Ladefoged [1971, p. 68] and in English see Ladefoged [1975, p. 13]). If we presume that there are four real factors, however, then we must consider both factors 2 and 4 to contribute to what is traditionally called height. The similarity between these two factors is evident from the 2 vs. 4 plot, in which all eight vowels are more nearly on a straight line than in any of the other plots.

The three-factor solution may shed some light on this problem of having two similar components. Table 8 provides us with the factor loadings for the three-factor unique solution and figure 28 gives us the analogical representation.

Table 8. Factor loadings: Three-factor solution. Correlation squared = 0.8246210 (@ 410 iterations).

MODE A: SPEAKERS

1	1.616	1.029	-0.8624
2	0.7367	1.326	0.2436
3	1.443	0.4468	-0.3236
4	-0.3714	0.4038E-01	2.078
5	0.7645	1.233	0.7943
6	0.2034	1.210	0.3768

MODE B: VOWELS

1 [i]	1.167	1.332	1.609
2 [ɪ]	0.1300	-1.224	1.365
3 [e]	0.7750	0.3767E-01	0.4412
4 [ɛ]	0.4641	-0.7943	-0.2662
5 [o]	-0.9624	-0.1413	-1.026
6 [ɔ]	-1.455	-1.285	-1.583
7 [u]	-0.6386	1.799	-0.1405
8 [ɔ]	-0.7141	-0.8178	-0.2582

MODE C: VOCAL TRACT SECTIONS

1	-0.1751	0.1745	-0.9109E-05
2	-0.9694E-01	0.2188	0.7848E-02
3	-0.4953E-02	0.2993	0.3692E-01
4	-0.2145E-01	0.4183	0.8870E-01
5	0.1784	0.4407	0.3499
6	0.2118	0.3530	0.3994
7	0.2246	0.2456	0.4199
8	0.1966	0.2162	0.3533
9	0.1402	0.4081E-01	0.2744
10	-0.7563E-02	-0.5999E-01	0.1874
11	-0.1699	-0.1454	0.1899E-01
12	-0.3034	-0.1903	-0.1229
13	-0.4494	-0.1992	-0.2091
14	-0.5031	-0.1729	-0.2585
15	-0.4798	-0.1729	-0.2705
16	-0.4729	-0.8530E-01	-0.2675

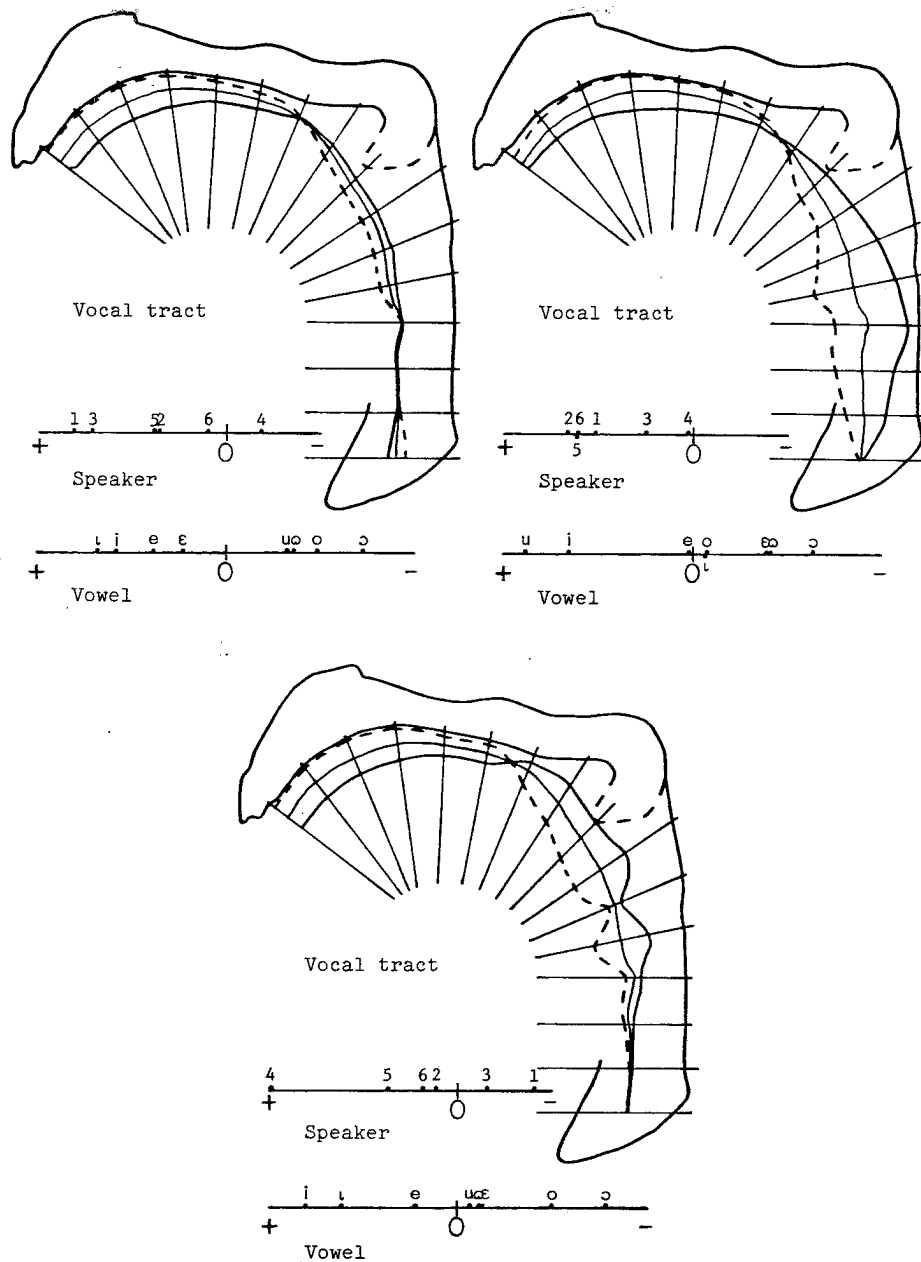

Figure 28. Analogical representation of a unique three-factor solution (six speakers, sixteen sections). Compare with table 8.

Factor 1 again is easily isolated as FRONT/BACK. This factor has frontal activity like its four-factor counterpart, but also has a little bit of the second-factor upper pharyngeal activity which is present in its four-factor counterpart.

Factor 2 is also easily identified. This is what we labeled TONGUE ROOT, however it is not as good an indicator here as it is at 4 factors in that all the vowels of one category are not separate as a group from all the vowels of the other category. Note that the speaker loadings have the same rank order on the solutions of different dimensionality, but that in this three-factor solution speakers 3 and 4 are not aberrant.

When the data are transcribed in terms of two factors (see figure 30, below) we still have a factor that separates front vowels from back vowels very strongly. In fact this FRONT/BACK component is so similar between the 2-factor and 3-factor solutions -- the vowel loadings are virtually identical -- that we can claim that factors 2 and 3 of the 3-factor solution can be derived from the other, the second, factor of the 2-factor solution.

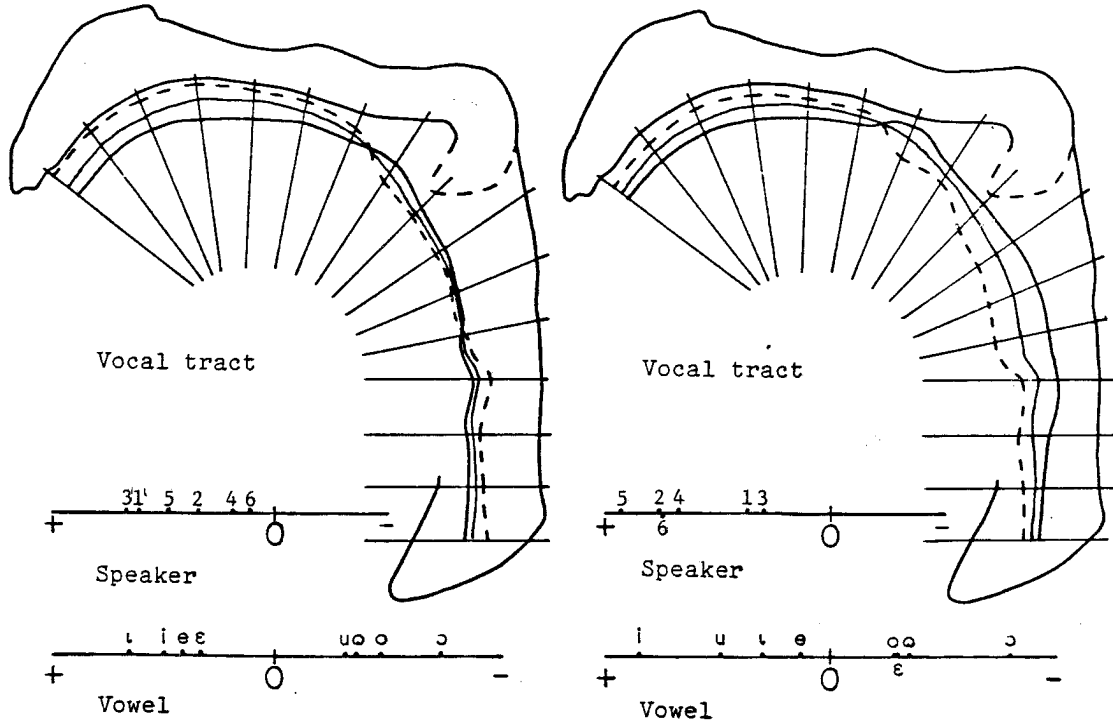

Figure 30. Analogical representation of a unique two-factor solution (six speakers, sixteen sections).

This second factor cannot be described in terms of any single phonological parameter -- although it does maintain a pairwise distinction for phonological vowel harmony. By ascribing greater height to [o] than to [ɔ] it fails to maintain a phonological height distinction. These two factors are plotted against each other in the graph of figure 31.

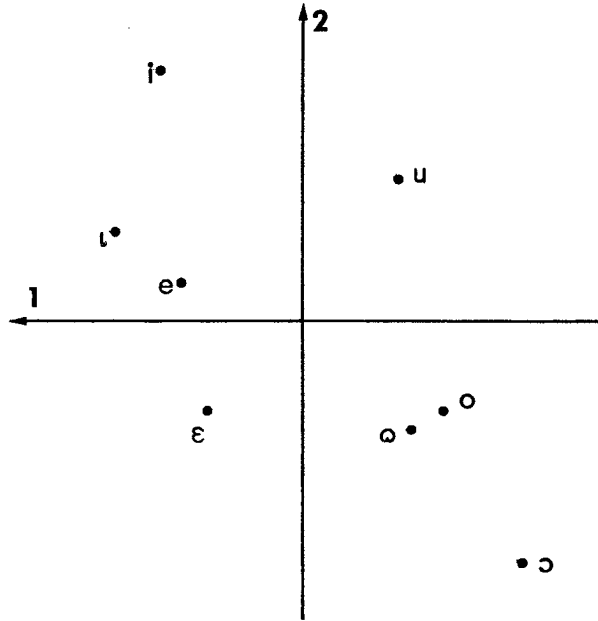

Figure 31. Vowel loading graph (2 factors, 6 speakers, 16 sections).

This graph clearly shows the ability of the first factor in separating the front vowels from the back vowels. The second factor, however, cannot be interpreted in terms of height (because of its inability to maintain the proper relationship between [o] and [ɔ]) nor in terms of vowel harmony (except in a pairwise fashion). Perhaps this confusion would be resolved if we used a smaller population where we controlled for divergent behavior of some of the speakers. Let us consider the analysis done with the four most "reliable" speakers.

FOUR-SUBJECT SOLUTION

We have seen so far with our six-subject solution that there is not a well-defined bend in the goodness of fit curve nor is interpretation of the factors in phonological terms obvious. With the exception of a clear FRONT/BACK parameter, interpretation of the factors is complex (and, in some cases, capable of multiple interpretations). This is further complicated by the presence of five negative person loadings at substantive dimensionalities. Four of these instances of contrary speaker behavior can be attributed to two speakers. I felt justified in eliminating the data for these two speakers and reanalyzing the remaining data, presuming that the analysis was being forced to go to a higher number of factors to account for this idiosyncratic behavior. When this was done a substantial improvement in the fit and a well-defined bend in the goodness of fit curve at 3 factors resulted.

The analogical representations and vowel loading graphs for the three- and two-factor solutions will now be presented and discussed.

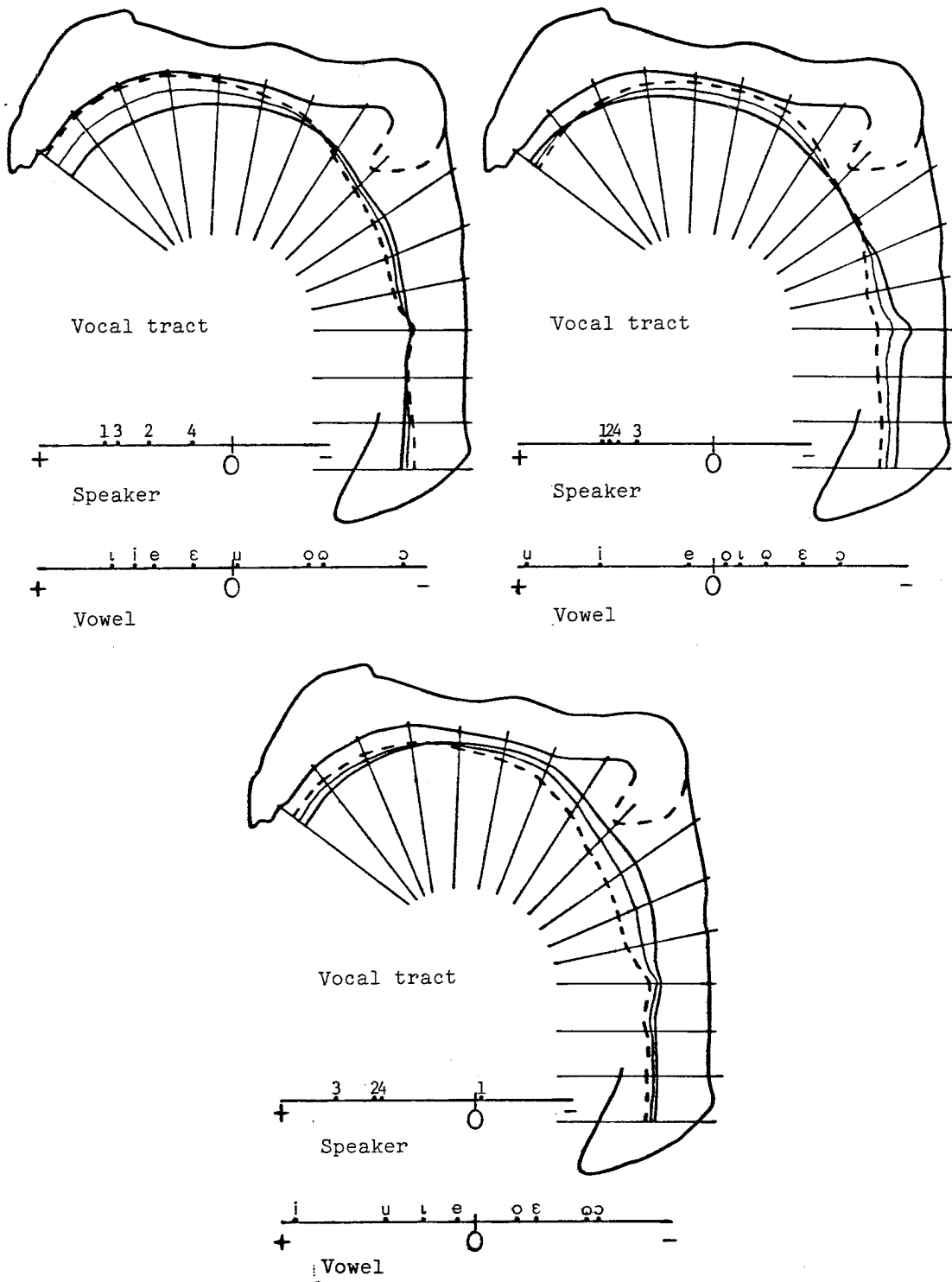

Figure 32. Analogical representation of a unique three-factor solution (four speakers, sixteen sections).

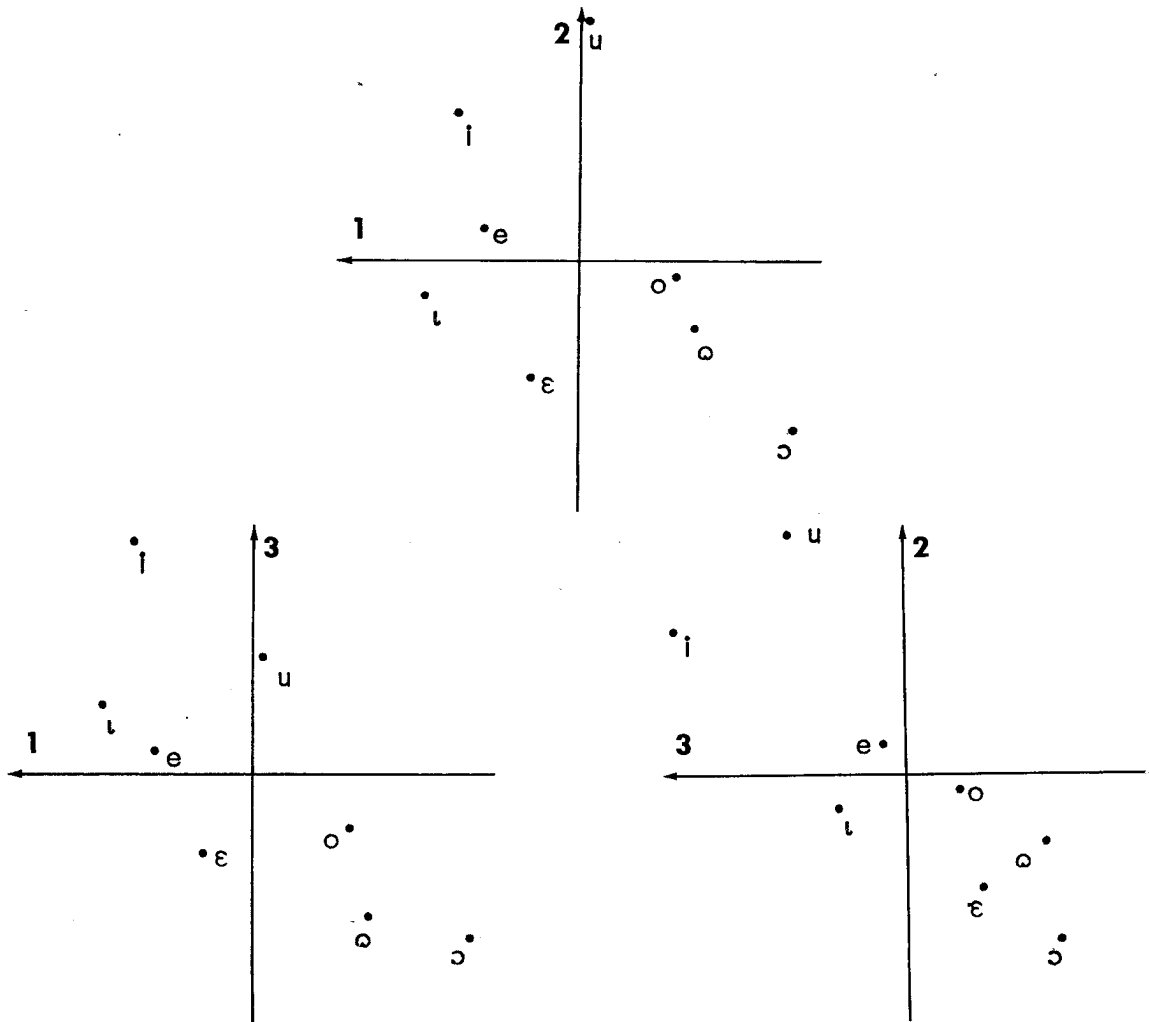

Figure 33. Vowel loading graphs (3 factors, 4 speakers, 16 sections)

We see here that there is a discrete separation of front vowels from back vowels for factor 1. No other phonological correlate can be attributed to this FRONT/BACK factor.

The second factor provides a discrete separation of the vowel harmony classes, so it corresponds to the TONGUE ROOT factor of other solutions. This factor can also distinguish for height within the harmony categories.

Three speakers use the third factor, essentially (note the very small negative person loading for speaker 1), which could account for height except for the placement of [ɔ]. Within the height moieties, there is a pairwise distinction for tongue root.

Note the similarity of these three scales, especially between factor 3 and the others.

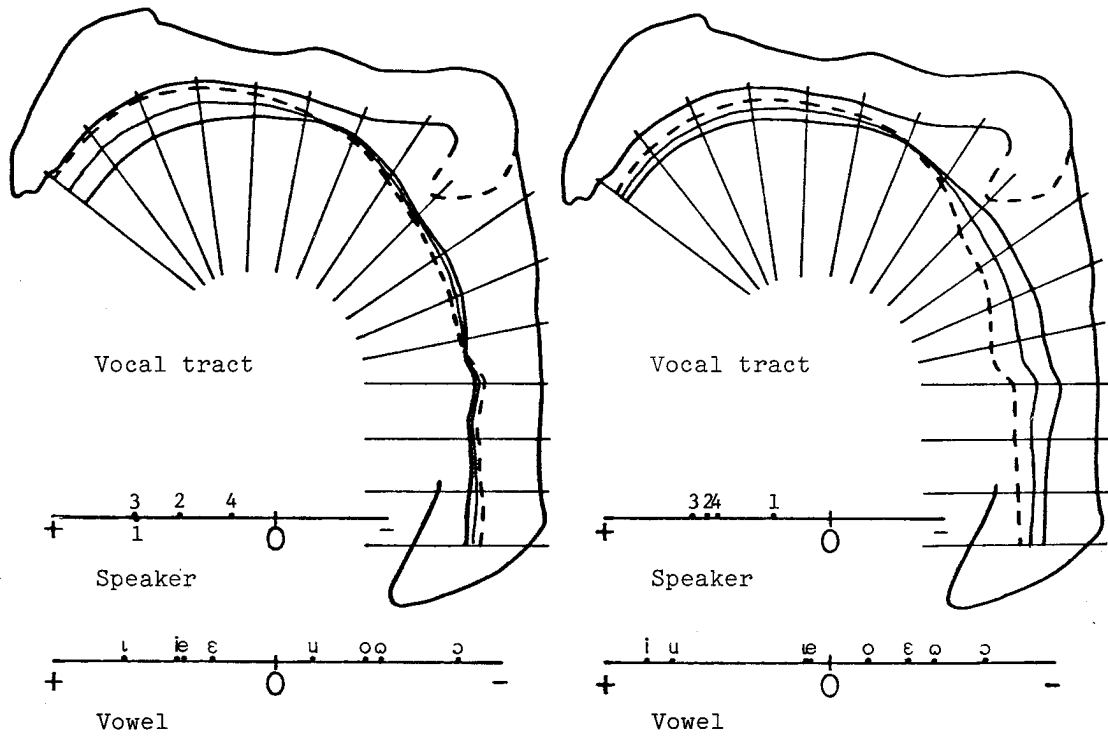

Figure 34. Analogical representation of a unique two-factor solution (four speakers, sixteen sections).

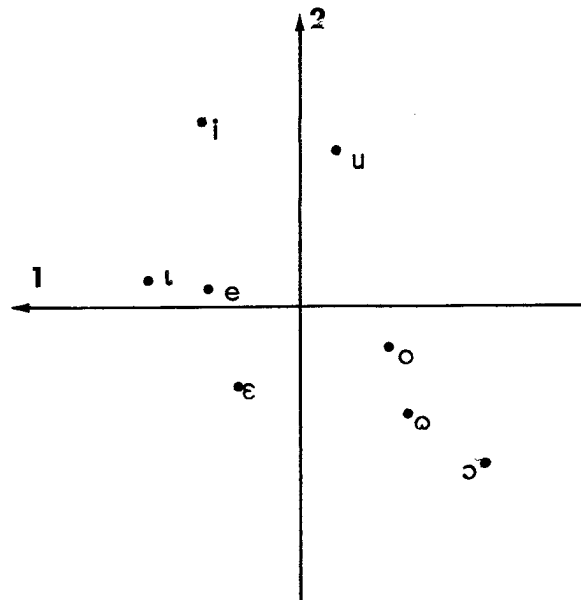

Figure 35. Vowel loading graph (2 factors, 4 speakers, 16 sections).

DISCUSSION

The graphs for the two-factor solution are essentially the same for both the six-subject and the four-subject analyses. The only noticeable difference in the plots is the position of [ɔ] in the vowel loadings. In a large sense then, the two subjects who were eliminated from the data set behaved differently with respect to [ɔ] than the others. This is easily confirmed by referring back to tables 1 and 2 (pages 30 and 31) where we see that both of the speakers in question, 3 and 4, have a higher tongue value and a wider pharynx value for [ɔ] than for [u]. We also notice in these tables that out of 15 counterpredictive differences in measurement between adjacent vowels, 11 of them involve the vowel [ɔ] (the other four involve [ʌ]). In some sense the production of the high "creaky" vowels, [ʌ] and [ɔ], is highly variable and inconsistent with our expectations. Bearing this behavior in mind, the two-dimensional plots in figure 31 (6 speakers) and figure 35 (4 speakers) do not look unreasonable. If the loadings for [ʌ] and, especially, [ɔ] were a bit higher, we would have a rather standard distribution of vowels with respect to traditional vowel parameters.

The first factor in this solution, the FRONT/BACK parameter, decisively separates front vowels from back vowels. The other factor in this solution cannot be so easily interpreted. It has the appearance of distinguishing vowels by height, except for [ɔ], but it also distinguishes, in a pairwise fashion, the vowel harmony classes.

When we analyze at the next higher number of factors, in addition to the FRONT/BACK parameter, we still have a factor that almost distinguishes for height, again except for [ɔ]; but at this dimensionality (3 factors) we also get a clear and interpretable factor for vowel harmony. This TONGUE ROOT parameter at 3 factors discretely separates all the "breathy" vowels from all the "creaky" vowels.

It is beyond this point for the four-subject analysis that we can not claim to have a substantive improvement in the fit of the modeled data to the actual data. If we look at the four-factor solution for the four-subject analysis (see appendix IV, figure A13) we will find no similarity between it and its counterpart solution with six subjects (see appendix IV for ready comparisons of the solutions) nor with any of the solutions for four subjects. Besides this, not one of its factors is interpretable with respect to height or front/back distinctions.

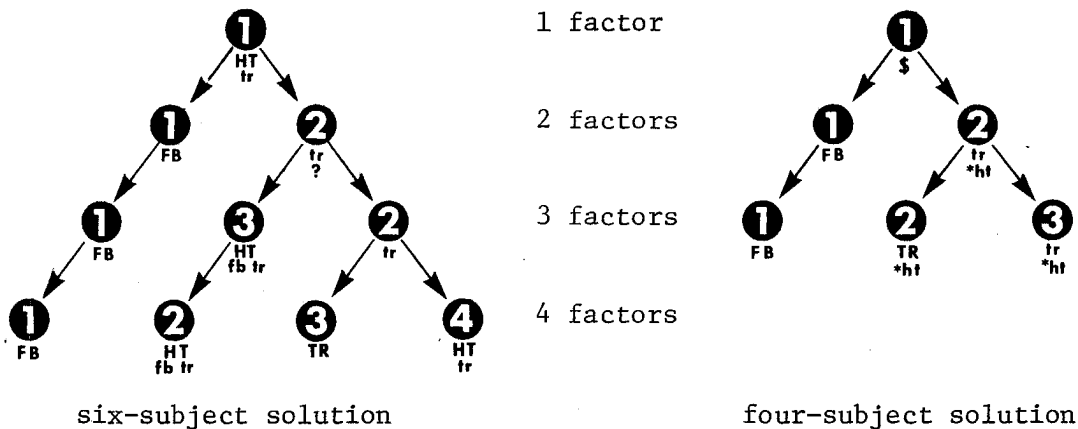

Figure 36. Ontogeny of the factor analysis solutions to their highest meaningful dimensionalities. (Upper case letters indicate an independent factor; fb = front/back, tr = tongue root, ht = height; \$ = indivisible, * = "not quite", ? = "something else, but not clearly discernible".)

Glancing at figure 36, which shows the ontogeny of the solutions for different numbers of factors, we can see that the front/back component establishes itself early against the "harmony" components -- which are bound up with tongue root, height, and (marginally) front/back. The arrows indicate a relationship between the factors of different dimensionalities as evidenced by the factor loadings; they do not imply that as a solution is iterated from its random starting point it must pass through any stages of development suggested by a solution of lower dimensionality.

The goodness of fit curve gives a clear bend at 3 factors for the four-subject solution. Each of these factors is interpretable phonologically (allowing for the "misbehavior" of [o]). At a higher dimensionality the factors do not lend themselves to interpretation. A subject population of four speakers is too small for making any valid conclusions -- especially since the process of elimination I employed selected for speakers who behaved similarly.

Using a larger sample -- a population of six speakers -- we find that four factors appear to be meaningful. It seems that the additional factor is required in order to account for the different behavior of the additional speakers. This extra factor does result in a superior solution, in fact, with respect to phonological interpretability.

My conclusion would be that there are four factors for accounting for the contrasts in the DhoLuo vowel system, but that any given speaker may choose them differently. All speakers will have the front/back component, but a speaker may select for using height or tongue root or both for maintaining the phonological contrasts among the vowels. It is this variability that results in having as many as four meaningful factors.

Still, because of the small number of speakers involved in this investigation, the conclusions reached must remain tentative -- the analysis may not be stable or well-determined. The highly correlated vowel loadings between some of the factors suggest that the solution may be of a lower dimensionality than I am suggesting and that one factor may be represented by two "semifactors" as the next higher dimensionality.

Another, and more serious, reservation is that this investigation did not in fact measure what it should have. As mentioned on page 45, my measurements are of vocal tract shape; it may be argued that what is wanted are measurements of tongue shape, as in the analysis of English vowels by Harshman, Ladefoged, and Goldstein [1977]. If this is the case, my entire analysis is specious and only valid to the point that vocal tract shape correlates with tongue shape. This will be discussed more in the next chapter, where we will compare our procedure with that of the Harshman, Ladefoged, and Goldstein study. In that chapter, as well, we will discuss other relevant works and comment on the implications of this study for linguistic theory.

Chapter seven: Comparisons and implications

In the previous chapters factor analyses of data that specify the shape of the vocal tract for a number of speakers during the production of eight vowels of the DhoLuo language have been described and interpreted. With the full data set for eight speakers the results were fuzzy and hard to interpret. After eliminating two speakers because of lacunae in their individual data sets (which had been filled in with interpolated values when the previous solution was run), our solution with six speakers did not result in a definite bend in the goodness of fit curve — one of the criteria used for deciding the number of meaningful factors. It was only after we analyzed data for the four "most uniform" speakers that a definite bend at 3 factors appeared in the goodness of fit curve. We were able to interpret these three factors in phonological terms as parameters for front/back, height, and vowel harmony — but this interpretation was not "clean" with respect to height since [o] was not properly placed phonologically. We were also able to determine that for our six-speaker solution these same three parameters were present, but that an additional factor for height was required. This four-factor solution resulted in a superior interpretation, even though it had several negative person loadings and two factors interpretable for height. We concluded that different speakers produced their vowels differently. One factor, the front/back parameter, was extracted early in every case and was used by all the speakers. The remaining factors were used to different extents by different speakers.

COMPARISON WITH OTHER FACTOR ANALYSES

In addition to the different use of these parameters by different speakers, another possible reason for not having a clearer solution could be that interpretation of the analyses was affected by the measurements that I used. These measurements were of distances between the tongue and the upper or back surface of the vocal tract (which I earlier called the passive surface of articulation) along a number of reference lines. As such they specify cross dimensions of the vocal tract and are in a direct mathematical relationship to the volume of the vocal tract. However, this articulatory surface is hardly passive, since the velum and rear pharyngeal wall can be in constant motion during speech. Just how much this surface moves during vowel production has never been determined, but it is certainly possible that such movement is not consistent from utterance to utterance and has therefore affected the results of this study. The other point to be made is that this procedure does not directly measure tongue movement. It may be the case that a measurement of tongue movement would achieve a better solution, especially one in terms of articulatory parameters. This, in particular, is the view held in the only other study to use a factor-analytic procedure to characterize articulatory effects of a vowel system: the Harshman, Ladefoged and Goldstein [1977; henceforth HLG] factor analysis of tongue shapes for vowels of American English.

A counterargument to the HLG point of view is that acoustic parameters are more meaningful for vowels than articulatory parameters are, and that the acoustically meaningful features — the formant frequencies — are

a function of the shape of the vocal tract. Thus, it is really the shape of the vocal tract that should concern us with a study of vowels and not the shape of the tongue. This is, of course, an empirical question; which approach describes more? The correlation between the original data and the data as modeled by the PARAFAC procedure cannot be used to settle this question, since these values are essentially the same for the two studies. Harshman, Ladefoged, and Goldstein [1977:792] achieve a correlation of 0.9626 for five subjects, ten vowels, and thirteen sections. While my eight-vowel study has correlations of 0.9374 (six subjects) and 0.9395 (four subjects) for analyses of the entire vocal tract (sixteen sections), the truncated, twelve-section, analyses without the lower pharynx are more directly comparable to the HLG study, which also eliminated the lower pharynx values. The correlations for my twelve-section analyses with values of 0.9648 (four subjects) and 0.9650 (six subjects) are slightly superior to the HLG results.

These two studies are only similar in this regard, however, since the HLG results show that two factors, a front-raising parameter and a back-raising parameter, are sufficient for characterizing English vowels. Further, these two parameters are completely different in pattern and function from the four parameters that result from the DhoLuo study. This would appear disappointing for someone who expected the parameters of vowel production to be the same from language to language. Of course, for these two factor-analysis investigations to be truly comparable the same measurement procedures would have had to be used. Such a comparative investigation is a clearly indicated avenue for future work. However, the differences in measurement techniques are not so great as the different results achieved. How can we account for these differences?

First, DhoLuo and English have very different vowel systems. There is no phonological vowel harmony in English. One of the factors extracted in DhoLuo can be interpreted to be just for distinguishing vowel harmony membership. Secondly, the HLG study for English had only five subjects. A larger population might have resulted in the extraction of more meaningful factors, just as my six-subject analyses required one more factor than the four-subject analyses. Indeed, the PARAFAC procedure might be too strong for our purposes and extract factors from the data that are not linguistically significant but are required only to account for individual differences in vowel production.

COMPARISON WITH OTHER AFRICAN LANGUAGES

Vowel harmony is a well-known phenomenon in African languages, especially among the Kwa languages [Stewart 1967, 1971] of West Africa and the Nilotic languages [Tucker and Bryan 1966; Hall, et al. 1974] of East Africa. There have been several radiographic investigations concerned with this phenomenon, notably Ladefoged [1964] for Igbo; Lindau, Jacobson, and Ladefoged [1972] for Twi, Igbo, Ateso, and DhoLuo; Lindau [1975] for Akan, Ijò, and Igbo; Painter [1973] for Twi; and Retord

[1972] for Anyi. My study is the only radiographic investigation of an African vowel system which uses a factor-analytic procedure, so any comparisons made with these other studies must be based on traditional measurements. The measurements reported for DhoLuo in chapter three for quantifying the highest point of the tongue and the most advanced point of the root of the tongue are useful for this purpose.

Lindau [1975] provides a useful review of this radiographic work, including her own investigation which represented three African languages: Akan (including the Twi dialect; four speakers), Ijò (one speaker), and Igbo (one speaker). All of the speakers in her investigation used tongue root advancement together with laryngeal depression to characterize the first harmony set (the "close" one); none of these speakers used tongue height -- which is predictable from pharynx width in these cases -- to distinguish vowel harmony categories. The DhoLuo and Ateso results (from Lindau, Jacobson, and Ladefoged [1972]) did not provide clear measurable outlines for the larynx and while the Ateso speaker used tongue height to distinguish vowel harmony, we were unsure how characteristic his behavior was. The other Twi study [Painter 1973] and the Anyi study [Retord 1972] confirm that advancement of the tongue is used to distinguish for vowel harmony, but their studies, like those for DhoLuo and Ateso, lacked measurements of laryngeal displacement. Lindau claims that it is probable that all African vowel harmony languages use the same articulatory mechanism for distinguishing vowel harmony -- an expansion of the pharynx; that is, an advancement of the root of the tongue with a concomitant depression of the larynx.

My investigation shows conclusively that for East African vowel harmony languages -- as represented by DhoLuo -- either tongue height or tongue root (pharynx width) can be used to distinguish the vowel harmony categories. Also, an expansion of the pharynx does not necessarily involve a depression of the larynx. In the West African languages studied so far, this has not been the case. Behavior in DhoLuo is not so uniform as that reported for the West African languages: one DhoLuo speaker may distinguish the vowel harmony categories almost exclusively by means of tongue height while another speaker uses width of the pharynx and a third speaker uses both. My findings clearly do not support Lindau's prediction that all African vowel harmony languages use the same articulatory mechanisms for determining vowel harmony membership.

This difference in behavior between speakers of West African vowel harmony languages and East African vowel harmony languages appears difficult to explain; why should the speaker of DhoLuo be able to speak with greater freedom of articulatory choice? I would suggest that the answer is two-fold. First, it could be that there are not enough subjects in the West African studies. A study with more speakers of Twi, for example, might reveal that there are several different articulatory gestures used in Twi to achieve the same vowel. Secondly, the speaker of DhoLuo is just as constrained as the speaker of Twi, but different aspects of the speech signal are distinctive in the different languages. The articulatory freedom permitted among speakers of DhoLuo would be understandable if some aspect of the speech signal other than articulatory vowel quality were distinctive. I would suggest that this is the case and that the distinctive aspect is one of voice quality.

VOICE QUALITY

The presence of voice quality differences has been noted for both the West African and the East African languages, and it is reflected in the impressionistic terms that have been used: brassy, muffled, hollow, creaky, breathy, for example. However, for the West African languages this distinction, while noted, is redundant. Stewart [1967] for example, says that breathiness is associated with the raised vowels, but it is not considered distinctive.

In the Western Nilotic languages of Shilluk and Dinka, I have claimed that the voice quality distinction is crucial [Jacobson, to appear in Vago (forthcoming)]. In these languages, like DhoLuo, the width of the pharynx is independent of the height of the tongue or the depth of the larynx. For Dinka, in particular, my data indicate that articulatorily-based distinctions (such as width of the pharynx) are not sufficient for distinguishing the vowel harmony categories. In DhoLuo the situation is not so extreme, to be sure, but there the suggestion is that auditory distinctions which appear to be redundant may in fact be the significant perceptual cues used by the speaker of the language. If this is the case, it would explain the relative freedom the speaker of DhoLuo has with respect to other aspects of vowel quality.

PHONOLOGICAL IMPLICATIONS

We now have to consider the implications of the fact that different speakers have different articulatory means for achieving the same phonological effects. The necessary phonological distinction for vowel harmony in DhoLuo, for example, can be achieved articulatorily in a number of manners. The height of the tongue, the advancement of the root of the tongue, and the depth of the larynx can be used singly or in any combination for maintaining this distinction. The various uses of these components is largely idiosyncratic, although some gestures are more pronounced for high vowels than for low vowels. Besides these articulatory components, there may also be an auditory component for a difference in quality of voicing, but this study was unable to measure this aspect of the speech signal.

Within a phonological description of DhoLuo, I should think a single cover feature has to be used which can be realized in a number of ways phonetically. The feature must not be called "tense/lax", since this has been used-- very confusingly-- differently for different languages. It may be argued that this approach obscures the differences, but this is what is required at the phonological level. At a phonetic level more exact specifications can be made, although with such variable articulatory behavior among speakers, it may be speculated that exact mechanisms can never be fully specified.

Linguistic metatheory will have to make clear that cross category vowel harmony can take many forms. Within a language one phonological cover term may have different phonetic realizations by different speakers. In comparing several African vowel harmony languages, it will have to be borne in mind that the same phonological cover term may have different phonetic consequences in different languages.

Appendix I: Technical specifications

AUDIO Microphone: dynamic omnidirectional cardioid
 [Sennheiser MD 21]
 maximum frequency deviation: ± 3 db
 output level: -53 db
 E.I.A. rating: -145.8 db

 Taperecorder: single track reel-to-reel
 [Nagra III] @ 19 cm/sec
 Signal to noise ratio: 60 db
 Frequency response: 40-12,000 Hz ± 2 db
 Flutter and wow: 0.14% rms

 Magnetic tape: 1.5 mil polyester based
 [Scotch 202]

SPECTROGRAPHIC Sound spectrograph: 85-8,000 Hz spectrum analyzer
 [Kay 6061A] with scale magnifier.

RADIOGRAPHIC X-ray machine: Horizontal polytome [Philips H]
 Focal distance: 173 cm
 Enlargement factor: 1.6
 Linear longitudinal movement: 30°
 Resultant exposure time: 0.47 sec
 Radiation: 300 mA @ 62 ± 2 kV
 Film: X-ray safety film [Dupont Cronex]
 Development: normal

COMPUTATIONAL Computer: 12-bit minicomputer [D.E.C. PDP-12]
 with 32k memory and floating point
 processor
 Programs: PARAFAC2, PARAFAC2A, PARAFAC4B
 [Richard Harshman]

Appendix II: Measurement values (raw data)

SPEAKER 1		VOWELS							
Section	[i]	[ɪ]	[e]	[ɛ]	[o]	[ɔ]	[u]	[ʊ]	
1	2.65	1.80	1.45	2.05	2.63	2.40	3.25	2.60	
2	2.40	2.10	2.35	2.20	2.50	2.30	3.15	2.25	
3	3.15	2.45	2.70	2.15	2.50	1.95	3.25	2.00	
4	2.45	2.45	2.45	1.90	2.17	1.40	3.05	1.55	
5	2.80	2.95	3.05	2.00	2.25	1.80	3.30	1.85	
6	2.60	2.80	2.40	2.50	2.05	1.75	2.85	1.85	
7	2.45	2.65	2.20	2.60	2.05	1.85	2.25	2.00	
8	1.10	1.30	0.90	1.65	0.90	0.90	0.67	0.80	
9	1.10	1.40	0.75	1.65	1.10	1.25	0.63	1.25	
10	0.60	0.70	0.50	1.65	1.05	1.53	0.40	1.15	
11	0.40	0.40	0.45	1.50	1.25	1.90	0.40	1.40	
12	0.65	0.55	0.85	1.60	1.70	2.40	0.63	1.75	
13	0.70	0.55	0.95	1.75	2.35	2.80	1.23	2.20	
14	0.70	0.55	0.95	1.65	2.55	2.85	1.63	2.25	
15	0.50	0.55	0.80	1.25	2.25	2.37	1.60	2.00	
16	1.15	1.20	1.35	1.50	2.80	2.63	2.60	2.60	
17	0.45	0.45	0.60	0.45	0.60	0.60	0.33	0.25	
18	0.80	0.85	1.25	1.35	0.50	0.75	0.20	0.33	
19	12.05	11.80	11.25	11.80	12.05	11.90	12.50	11.90	
F ₁	275	300	400	525	450	570	275	360	
F ₂	2200	2100	2040	1860	870	1080	775	675	
F ₃	3050	2975	2850	2635	2450	2270	2625	2375	

SPEAKER 2		VOWELS							
Section	[i]	[ɪ]	[e]	[ɛ]	[o]	[ɔ]	[u]	[ʊ]	
1	3.25	1.65	2.83	2.45	2.40	2.60	2.45	2.10	
2	2.95	1.80	2.25	1.85	2.40	2.30	2.60	1.70	
3	3.30	1.95	2.40	2.00	2.30	1.90	2.35	1.63	
4	2.65	1.45	1.70	1.90	1.43	1.65	4.00	0.65	
5	4.40	2.90	3.35	2.87	2.75	1.05	3.85	2.10	
6	4.45	3.70	3.70	3.43	2.75	1.97	3.85	2.17	
7	4.50	4.05	3.60	3.17	2.60	2.20	3.60	2.30	
8	2.55	0.90	1.30	0.45	0.93	2.17	1.75	0.35	
9	2.05	1.50	1.43	1.20	0.90	0.30	1.10	0.60	
10	1.10	1.10	1.07	1.25	0.70	1.05	0.90	0.50	
11	0.70	0.95	0.90	1.15	1.07	1.20	0.50	0.77	
12	0.50	0.85	0.90	1.05	1.60	1.80	0.45	1.30	
13	0.47	0.80	0.93	1.17	2.10	2.25	0.75	1.80	
14	0.43	0.70	0.95	1.20	2.25	2.57	1.05	2.00	
15	0.40	0.55	0.77	1.15	2.00	2.17	1.05	2.00	
16	0.47	0.85	0.80	1.27	1.75	2.05	1.40	2.00	
17	0.95	1.25	1.10	1.40	0.95	1.05	0.80	1.03	
18	1.10	1.25	0.85	1.10	0.70	0.70	0.70	0.50	
19	13.50	12.40	12.80	12.20	13.35	12.60	13.85	12.95	
F ₁	200	285	300	600	310	560	250	335	
F ₂	1900	1900	1770	1700	820	870	1000	800	
F ₃	2600	2500	2300	2250	2120	2100	2100	2200	

Appendix II: Measurement values (continued)

SPEAKER 3		VOWELS							
Section	[i]	[ɪ]	[e]	[ɛ]	[o]	[ɔ]	[u]	[ɔ̃]	
1	1.35	1.55	1.40	1.83	1.90	2.20	2.15	2.15	
2	2.20	2.30	2.25	1.70	1.90	2.13	2.60	2.75	
3	3.60	2.45	2.33	2.20	2.30	2.30	3.00	3.15	
4	2.65	2.27	2.33	2.13	2.20	1.85	2.95	3.00	
5	4.05	3.23	3.00	3.20	2.55	2.17	3.25	3.35	
6	3.57	2.90	2.93	2.60	2.40	2.15	2.70	2.70	
7	3.00	2.57	2.55	2.43	2.17	2.10	2.40	2.40	
8	1.05	0.70	0.87	0.73	0.01	0.01	0.23	0.33	
9	1.27	0.90	1.00	0.50	0.40	0.70	0.63	0.45	
10	0.55	0.37	0.65	0.55	0.60	1.35	0.55	0.47	
11	0.40	0.35	0.73	0.77	1.35	2.10	0.65	0.55	
12	0.40	0.47	1.00	1.17	2.10	2.70	1.20	1.15	
13	0.53	0.70	1.23	1.43	2.65	3.00	2.05	1.95	
14	0.65	0.85	1.33	1.55	2.65	2.90	2.47	2.40	
15	0.57	0.95	1.35	1.40	2.40	2.55	2.55	2.50	
16	0.80	0.80	1.10	1.23	2.55	2.50	2.13	2.07	
17	0.07	0.07	0.60	0.95	0.70	0.90	0.45	0.37	
18	1.05	1.20	1.60	1.50	0.75	1.25	0.47	0.30	
19	12.75	13.20	13.00	13.00	12.90	13.25	13.73	13.63	
F ₁	270	310	435	640	415	600	310	275	
F ₂	2285	1800	1920	1875	900	1050	1000	780	
F ₃	2900	2765	2500	2570	2675	2450	2450	2600	

SPEAKER 4		VOWELS							
Section	[i]	[ɪ]	[e]	[ɛ]	[o]	[ɔ]	[u]	[ɔ̃]	
1	2.30	2.05	2.05	1.75	2.35	2.25	1.30	1.30	
2	2.25	2.00	2.15	2.00	2.35	1.95	1.30	2.05	
3	2.20	2.00	1.70	1.55	2.40	1.30	1.85	2.00	
4	2.15	2.20	1.57	1.00	1.45	0.75	2.05	2.35	
5	4.20	3.80	2.93	1.90	1.60	1.15	2.75	3.00	
6	4.20	3.90	2.87	1.95	1.40	0.94	2.50	2.80	
7	4.50	4.20	3.20	2.45	1.60	1.35	2.60	2.65	
8	3.40	3.45	2.75	1.85	1.40	0.67	1.65	1.75	
9	3.05	3.30	2.40	2.23	1.05	1.23	1.50	1.80	
10	1.80	1.90	1.55	1.40	0.55	0.70	0.40	0.65	
11	0.75	1.10	1.10	1.10	0.80	1.05	0.50	0.35	
12	0.30	0.70	0.95	1.10	1.45	1.60	0.55	0.25	
13	0.27	0.65	1.00	1.23	1.90	1.90	0.70	0.37	
14	0.40	0.70	1.20	1.35	2.27	2.15	1.05	0.70	
15	0.50	0.80	1.25	1.53	2.35	2.15	1.20	0.85	
16	0.95	1.20	1.67	1.93	2.70	2.40	1.75	1.45	
17	0.30	0.77	0.60	0.75	0.77	0.65	0.37	0.30	
18	0.85	0.90	1.00	1.05	0.55	0.73	0.30	0.30	
19	12.45	12.10	12.15	11.40	12.25	11.80	12.25	12.90	
F ₁	240	320	330	530	350	550	250	315	
F ₂	2160	2150	2075	1930	860	875	900	800	
F ₃	3050	2900	2700	2635	2410	2450	2175	2200	

Appendix II: Measurement values (continued)

SPEAKER 5		VOWELS						
Section	[i]	[ɪ]	[e]	[ɛ]	[o]	[ɔ]	[u]	[ɔ]
1	2.90	2.40	2.93	2.80	2.23	2.95	3.17	2.95
2	2.90	2.35	2.45	2.60	2.63	2.40	3.10	2.60
3	2.65	2.20	2.30	2.05	2.40	1.83	3.05	2.20
4	2.45	1.80	1.77	1.55	1.83	1.15	2.80	1.63
5	4.70	3.57	3.90	2.05	2.75	1.50	4.57	1.95
6	4.75	3.50	2.83	1.95	2.43	1.30	4.10	1.80
7	4.75	3.40	2.93	2.20	2.43	1.43	3.35	1.80
8	2.85	2.17	1.55	1.30	1.13	0.47	2.00	0.90
9	1.85	1.45	1.15	1.20	0.60	0.60	1.10	0.55
10	1.05	1.03	0.65	0.90	0.40	0.75	0.45	0.30
11	0.60	0.80	0.47	0.87	0.70	1.55	0.45	0.80
12	0.50	0.70	0.50	1.00	1.20	2.20	0.67	1.63
13	0.40	0.67	0.67	1.10	1.65	2.83	1.00	2.35
14	0.40	0.60	0.75	1.15	2.00	3.10	1.20	2.60
15	0.35	0.55	1.07	1.10	2.00	3.25	1.30	2.70
16	1.00	1.10	2.00	1.70	2.65	3.95	2.05	3.40
17	0.73	1.35	1.10	1.70	2.95	2.95	1.90	2.55
18	0.75	0.90	1.25	1.85	2.30	2.00	0.95	0.40
19	12.05	11.80	11.55	11.10	11.50	11.45	11.85	11.60
F ₁	245	295	345	520	335	450	255	300
F ₂	2000	1950	2000	1850	775	785	900	800
F ₃	2600	2650	2550	2550	2200	2000	2500	2200

SPEAKER 6		VOWELS						
Section	[i]	[ɪ]	[e]	[ɛ]	[o]	[ɔ]	[u]	[ɔ]
1	3.63	2.90	2.70	1.73	3.33	2.20	3.57	3.37
2	3.45	2.80	3.25	2.65	2.60	2.55	3.50	3.10
3	3.55	2.90	3.00	2.60	2.83	2.33	3.65	3.25
4	3.65	3.17	3.10	1.93	2.70	2.00	3.13	3.13
5	5.35	4.20	3.87	2.87	3.05	1.80	4.75	4.40
6	5.33	4.00	3.67	2.85	2.50	1.45	4.50	4.16
7	5.23	3.90	3.70	3.17	2.37	1.70	3.50	3.77
8	3.90	2.30	2.15	1.77	0.65	1.13	1.80	2.15
9	3.20	1.70	1.75	1.45	0.97	1.30	1.30	1.55
10	1.83	0.75	1.00	0.93	0.70	1.50	0.65	0.75
11	0.90	0.63	0.90	1.35	1.15	2.45	0.47	0.60
12	0.40	0.55	0.90	1.45	1.73	3.80	0.63	0.60
13	0.45	0.57	0.95	1.50	2.10	*.**	1.05	0.93
14	0.40	0.75	0.95	1.47	2.80	*.**	1.40	1.05
15	0.40	0.95	1.00	1.50	4.00	*.**	1.63	1.25
16	1.50*	1.50*	1.50*	2.00*	3.90	*.**	2.40	*.**
17	0.53	0.65	0.65	1.05	0.90	1.25	0.50	0.01
18	1.15	1.60	1.35	1.57	0.93	1.20	0.40	0.40
19	13.95	**.**	13.25	13.00	14.50*	13.95*	13.00*	12.65*
F ₁	305	385	410	565	435	575	315	395
F ₂	2300	2275	2130	1990	800	980	925	770
F ₃	3000	2925	2650	2720	2350	2500	2200	2330

Appendix II: Measurement values (continued)

SPEAKER 7		VOWELS							
Section	[i]	[ɪ]	[e]	[ɛ]	[o]	[ɔ]	[u]	[ʊ]	
1	3.05	2.90	2.60		2.90	2.60	3.85	3.55	
2	4.00	3.60	3.25		2.80	2.45	3.85	3.55	
3	4.75	4.35	3.95		2.60	2.37	3.70	3.70	
4	4.27	4.00	3.65		1.70	1.45	2.93	3.05	
5	5.80	5.40	5.93		2.45	2.45	3.75	3.70	
6	5.43	4.93	4.85		2.45	2.50	3.45	3.40	
7	4.75	4.57	4.57		2.65	2.85	3.45	3.20	
8	3.33	3.10	2.83		1.53	1.45	2.15	2.05	
9	2.50	2.70	2.60		1.65	2.15	1.75	1.47	
10	1.30	1.40	1.50		1.10	1.80	0.70	0.60	
11	0.90	1.10	1.27		1.30	2.10	0.75	0.50	
12	0.55	0.90	1.07		2.05	2.55	1.10	0.65	
13	0.60	0.75	0.97		2.87	2.05	1.47	0.93	
14	0.67	0.75	1.07		3.00	3.00	1.63	1.23	
15	1.00	0.90	1.35		***	***	1.95	2.15	
16	***	1.33	1.80		***	***	3.90	3.90	
17	0.60	0.70	1.13		0.60	0.80	1.05	0.40	
18	1.20*	1.75	1.67		0.85	0.80	0.85	0.80	
19	13.85	13.45	13.35		13.15	13.15	13.25	12.85	
F ₁	235	275	360	500	400	475	230	280	
F ₂	1900	1775	1665	1640	825	860	675	690	
F ₃	2555	2550	2600	2255	2050	2000	1840	1840	

SPEAKER 8		VOWELS							
Section	[i]	[ɪ]	[e]	[ɛ]	[o]	[ɔ]	[u]	[ʊ]	
1	3.83	2.95	2.90	2.85	2.87	2.60	3.35	2.87	
2	4.03	2.67	2.67	2.67	2.70	2.35	3.17	2.70	
3	4.25	2.80	3.75	2.25	2.75	2.33	3.70	2.70	
4	3.97	2.80	2.57	1.87	2.70	2.00	3.70	2.50	
5	4.55	3.70	3.20	2.30	3.05	2.07	4.15	2.80	
6	4.00	3.25	3.15	2.37	2.80	1.95	3.65	2.53	
7	3.50	3.30	3.03	2.47	2.67	2.10	3.33	2.45	
8	1.93	1.57	1.57	0.67	1.05	0.50	1.97	0.87	
9	2.10	2.00	2.20	1.65	1.85	1.55	2.20	1.63	
10	1.10	1.20	1.25	0.90	0.85	0.93	0.83	0.55	
11	0.60	0.80	0.83	0.80	0.65	0.93	0.55	0.55	
12	0.40	0.63	0.70	0.80	0.55	1.20	0.40	0.53	
13	0.37	0.55	0.70	0.83	0.85	1.77	0.50	1.00	
14	0.50	0.53	0.70	0.90	1.10	2.00	0.55	1.25	
15	0.50	0.53	0.65	0.80	1.10	2.15	0.73	1.40	
16	0.67	0.65	0.75	0.83	1.05	2.07	0.95	1.40	
17	0.33	0.27	0.35	0.10	0.15	0.20	0.20	0.20	
18	0.37	0.65	0.73	0.73	0.50	0.40	0.40	0.35	
19	13.15	11.75	11.90	11.17	11.33	11.40	12.00	11.60	
F ₁	265	300	360	550	365	500	275	340	
F ₂	2100	2000	1900	1775	850	875	900	775	
F ₃	2850	2850	2600	2450	2250	2175	2100	2000	

Appendix III: Deviation values (processed data)

Appendix III: Deviation values (processed data). Different speakers are represented by the vertical columns within which every successive group of eight values consists of the vowel deviation values, each group of eight values being a different vocal tract section. Sections 17, 18, and 22 (the teeth, lips, and larynx depth deviation values) are reduced by a factor of 75(10)⁻⁶; sections 19-21 (the formant frequency deviation values) are reduced by 75(10)⁻⁹.

0.22219	0.61594	-0.34969	0.28594	0.81563E-01	0.52594	0.69375E-01	0.60187	[i] S
-0.41531	-0.58406	-0.19969	0.98438E-01	-0.29344	-0.21563E-01	-0.43125E-01	-0.58125E-01	[u] E
-0.67781	0.30094	-0.31219	0.98438E-01	0.10406	-0.17156	-0.26813	-0.95825E-01	[e] C
-0.22781	0.15937E-01	0.10313E-01	0.12556	0.65622E-02	0.89906	-0.56062	-0.13313	[e] T
0.20719	-0.21563E-01	0.62812E-01	0.32344	-0.42094	0.30094	-0.43125E-01	-0.11812	[o] I
0.34687E-01	0.96563E-01	0.28781	0.24844	-0.11906	0.54656	-0.26813	-0.32063	[o] O
0.67219	0.15937E-01	0.25031	-0.46406	0.28406	0.48094	0.66937	0.24187	[u] N
0.18469	-0.24656	0.25031	-0.46406	0.11906	0.33094	0.44437	-0.11812	[o] L
-0.46878E-02	0.57656	-0.21563E-01	0.18281	0.20344	0.34688	0.59250	0.87000	[i] S
-0.22969	-0.28594	0.53437E-01	0.46880E-02	0.20906	-0.14063	0.29250	-0.15000	[i] E
-0.42188E-01	0.51563E-01	0.15937E-01	0.18781	-0.13406	0.19688	0.30000E-01	-0.15000	[e] C
-0.15469	-0.24844	-0.39656	-0.46880E-02	0.21563E-01	0.25312	-0.77250	-0.15000	[e] T
0.70312E-01	0.16406	-0.24656	0.25781	0.93722E-03	0.29062	-0.30750	-0.12750	[o] I
-0.79688E-01	-0.21094	-0.74062E-01	0.42187E-01	-0.17156	-0.32813	-0.57000	-0.39000	[o] O
0.55781	0.31406	0.27844	-0.52969	0.35344	0.38438	0.48000	0.22500	[u] N
-0.11719	-0.36094	0.39094	0.32813E-01	0.21563E-01	0.84375E-01	0.25500	-0.12750	[u] S
-0.47344	0.82687	0.70031	0.22500	0.23625	0.40219	0.98156	0.88781	[o] 2
-0.51563E-01	0.18562	-0.16219	-0.22500	-0.18125	-0.85312E-01	0.68156	-0.19969	[i] S
0.13594	0.15188	-0.25219	-0.15000	-0.26250E-01	-0.10313E-01	0.38156	-0.51281	[i] E
-0.27656	-0.14812	-0.34969	-0.26250	-0.21375	-0.31031	-0.99844	-0.61219	[e] C
-0.14063E-01	0.76875E-01	0.27469	0.37500	0.48750E-01	0.13781	-0.63094	-0.23719	[e] T
-0.42656	-0.41062	-0.27469	-0.45000	-0.37875	-0.51281	-0.80344	-0.55219	[o] I
0.54844	0.11438	0.25031	-0.37500E-01	0.53625	0.47719	0.19406	0.47531	[o] O
-0.38906	-0.42562	0.36281	0.75000E-01	0.10125	0.17719	0.19406	-0.27469	[u] N
0.13781	1.2384	0.60938	0.93375	0.70500	1.1137	1.3444	1.0753	[o] 3
0.17531	-0.11156	0.13688	0.68625	0.18000	0.15375	1.0819	0.17531	[i] S
0.10031	0.90938E-01	0.27562	0.12375	-0.82500E-01	0.13875	0.69187	-0.49687E-01	[i] E
-0.38719	-0.38906	-0.51563	-0.66375	-0.68250	-0.92625	-1.2656	-0.79969	[e] C
-0.16219	0.93748E-03	0.31312	-0.43875	0.30000E-01	0.27375	-1.0331	-0.12187E-01	[e] T
0.10312E-01	0.88406	-0.61312	-1.0387	-0.90750	-1.2863	-1.2431	-0.79969	[o] I
0.66281	0.78844	0.36188	0.16125	1.1775	0.70125	0.25687	0.64781	[o] O
-0.53719	-0.73406	0.60938	0.23625	-0.42000	0.37875	0.16687	-0.23719	[u] N
0.22500	1.0322	0.71250	1.1503	1.1822	1.1728	1.3866	0.99187	[o] 4
0.33750	-0.92813E-01	0.97499E-01	0.85031	0.33469	0.31031	1.0866	0.35438	[i] S
0.41250	0.24469	-0.75000E-01	0.19781	0.58219	0.62812E-01	1.4841	-0.20625E-01	[i] E
-0.37500	-0.11531	0.75000E-01	0.57469	-0.80531	-0.68719	-1.3659	-0.69563	[e] C
-0.18750	-0.20531	-0.41250	-0.79969	-0.28031	-0.55219	-1.1259	-0.13313	[e] T
-0.52500	-0.79031	-0.69750	-1.1372	-1.2178	-1.4897	-1.1259	-0.86812	[o] I
0.60000	0.61969	0.11250	0.62813E-01	1.0847	0.72281	-0.15094	0.69187	[o] O
-0.48750	-0.65281	0.18750	-0.25031	-0.88031	0.46031	-0.18844	-0.32063	[u] N
								[o] 5

Appendix III: Deviation values (continued)

0.18750	0.87656	0.61969	1.2225	1.4381	1.3294	1.2778	0.77812	[I] S
0.33750	0.31406	0.11719	0.99750	0.50052	0.33187	0.90281	0.21562	[U] E
0.37500E-01	0.31406	0.13969	0.22500	-0.18754E-02	0.84375E-01	0.84281	0.14062	[U] C
0.11250	0.11156	-0.10781	-0.46500	-0.66187	-0.53063	-0.69469	-0.44438	[E] T
-0.23500	-0.33844	-0.25781	-0.87750	-0.30188	-0.79313	-0.95719	-0.12188	[O] I
-0.45000	-0.81094	-0.44531	-1.2225	-1.1494	-1.5806	-0.91969	-0.75938	[U] N
0.37500	0.42556	-0.32813E-01	-0.52500E-01	0.95063	0.70687	-0.20719	0.51562	[U] O
0.37500	-0.83344	-0.32813E-01	0.17250	-0.77438	0.45187	-0.24469	-0.32438	[O] 6
0.14531	0.93844	0.41062	1.2609	1.4728	1.3594	0.87375	0.48281	[I] S
0.29531	0.60094	0.88125E-01	1.0759	0.46031	0.36188	0.73875	0.33281	[U] E
-0.43188E-01	0.26344	0.73125E-01	0.28594	0.10781	0.21188	0.73875	0.13031	[E] C
0.25781	-0.59062E-01	0.16876E-01	0.27656	-0.43969	-0.18563	-0.70875	-0.28969	[E] T
-0.15469	-0.48656	-0.21187	-0.91406	-0.26719	-0.78562	-0.70125	-0.13969	[O] I
-0.30469	-0.80906	-0.26438	-1.1016	-1.0712	-1.2881	-0.55125	-0.56719	[O] N
-0.46878E-02	0.26344	-0.39375E-01	0.16406	0.42281	0.61875E-01	0.10125	0.39531	[U] N
-0.19219	-0.71156	-0.39375E-01	0.13556	-0.73969	0.26438	-0.28875	-0.30469	[O] 7
0.54375E-01	1.1128	0.42094	0.96375	0.97781	1.4391	0.84375	0.49781	[I] S
0.20437	-0.12469	0.15844	1.0012	0.46781	0.23906	0.67125	0.22781	[U] E
-0.95625E-01	0.17531	0.28594	0.47625	0.28124E-02	0.12656	0.46875	0.22781	[E] C
0.46687	-0.46219	-0.18094	-0.19825	-0.18469	-0.15844	-0.75375	-0.44719	[E] T
-0.95625E-01	0.10219	-0.36656	-0.53625	-0.31219	-0.99844	-0.50625	-0.16219	[O] I
-0.95625E-01	0.57469	-0.36656	-1.0637	-0.80719	-0.63844	-0.56625	-0.57469	[O] N
-0.26813	0.51281	-0.19406	-0.34875	0.34031	-0.13594	-0.41250E-01	0.52781	[U] N
-0.17063	-0.53719	-0.11906	-0.27375	-0.48469	0.12656	-0.11625	-0.29719	[O] 8
-0.30937E-01	0.61594	0.48406	0.73500	0.59063	1.1606	0.35344	0.15188	[I] S
0.19406	0.20344	0.12656	0.92250	0.29062	0.35625E-01	0.50344	0.76875E-01	[U] E
-0.29344	0.15094	0.20156	0.24750	0.65625E-01	0.73125E-01	0.42844	0.22688	[E] C
0.38156	-0.21563E-01	0.17344	0.12000	0.10312	-0.15188	-0.46406	-0.18563	[E] T
-0.30937E-01	0.24656	-0.24844	-0.76500	-0.34688	-0.51188	-0.28406	-0.35625E-01	[O] I
0.81563E-01	0.13406	-0.23438E-01	0.63000	-0.34688	-0.26438	0.90938E-01	0.26063	[O] N
-0.38344	-0.96563E-01	-0.75937E-01	0.42750	-0.28125E-01	-0.26438	-0.20906	-0.22688	[U] N
0.81563E-01	0.47156	-0.21094	-0.20250	-0.38438	-0.76875E-01	-0.41906	-0.20062	[O] 9
-0.26063	0.91875E-01	-0.64688E-01	0.51094	0.26906	0.61219	0.86250E-01	0.11156	[I] S
-0.18563	0.91875E-01	0.19969	0.58594	0.25406	-0.19781	0.16125	0.18656	[U] E
-0.33563	0.69375E-01	0.10312E-01	0.32344	-0.30938E-01	-0.10313E-01	0.23625	0.22406	[E] C
0.52687	0.20437	-0.64688E-01	0.21094	0.15656	-0.62813E-01	-0.78750E-01	0.38438E-01	[E] T
0.76875E-01	0.20813	-0.27188E-01	0.42656	-0.21844	-0.23531	-0.63750E-01	0.75938E-01	[O] I
0.43687	0.16687	0.53531	0.31406	0.44062E-01	0.36489	0.46125	-0.15938E-01	[O] N
-0.41063	-0.58125E-01	0.64688E-01	0.53906	-0.18094	-0.27281	-0.36375	-0.90938E-01	[O] 10
0.15187	-0.35813	-0.12469	-0.35156	-0.29344	-0.19781	-0.43875	-0.30094	[U] N
-0.42188	-0.21000	-0.34688	-0.70313E-01	-0.13500	-0.11719	-0.16875	-0.85313E-01	[O] 6
-0.42188	-0.22500E-01	0.38438	0.19219	0.15000E-01	0.31969	-0.18750E-01	0.64687E-01	[I] S
-0.38438	-0.60000E-01	0.99375E-01	0.19219	-0.23250	-0.11719	0.10875	0.87188E-01	[U] E
0.40312	0.12750	-0.69375E-01	0.19219	0.67500E-01	0.22031	-0.33750E-01	0.64687E-01	[E] C
0.21562	0.67500E-01	0.36562	-0.32812E-01	0.60000E-01	0.70312E-01	0.13125	-0.47813E-01	[E] T
0.70312	0.61500	0.92813	0.15469	0.57750	1.0453	0.73125	0.16219	[O] I
-0.42188	-0.36000	-0.15938	-0.25781	-0.24750	-0.43969	-0.28125	-0.12281	[O] N
0.32812	-0.15750	-0.23438	-0.37031	0.15000E-01	-0.34219	-0.46875	-0.12281	[O] 11

Appendix III: Deviation values (continued)

-0.46219	-0.45938	-0.65531	-0.42188	-0.41250	-0.64312	-0.52875	-0.18844	[] S
-0.53719	-0.19687	-0.60281	-0.12188	-0.26250	-0.53062	-0.26625	-0.15938E-01	[] E
-0.31219	-0.15938	-0.20531	0.65625E-01	-0.41250	-0.26813	-0.13875	0.36562E-01	[] C
0.25931	-0.46875E-01	-0.77813E-01	0.17812	-0.37500E-01	0.14438	-0.63750E-01	0.11156	[] T
0.32531	0.36563	0.61969	0.44063	0.11250	0.35438	0.59625	-0.75938E-01	[] I
0.85031	0.85312	1.0697	0.55312	0.86250	1.9069	0.97125	0.41156	[] O
-0.47719	-0.49688	-0.55313E-01	-0.23438	-0.28500	-0.47063	-0.11625	-0.18844	[] N
0.36281	0.14063	-0.92813E-01	0.45938	0.43500	-0.49313	-0.45375	-0.90938E-01	[]_12
-0.64969	-0.64031	-0.87188	-0.54938	-0.70031	-0.84844	-0.57469	-0.33844	[] S
-0.76219	-0.39281	-0.74438	-0.26438	-0.49781	-0.75844	-0.46219	-0.20344	[] E
-0.46219	-0.29531	-0.34688	-0.18750E-02	-0.49781	-0.47344	-0.29719	-0.90938E-01	[] C
0.13781	-0.11531	-0.19688	0.17062	-0.17531	-0.60938E-01	-0.57188E-01	0.65625E-02	[] T
0.58781	0.58219	0.71812	0.67312	0.23719	0.38906	1.1278	0.21562E-01	[] I
0.92531	0.93469	0.98062	0.67312	1.1222	2.6391	0.51281	0.71156	[] O
-0.25219	-0.43031	0.26813	-0.22688	-0.25031	-0.39844	0.77812E-01	-0.24894	[] N
0.47531	0.35719	0.19313	-0.47437	0.76219	-0.48844	-0.32719	0.13406	[]_13
-0.70594	-0.72281	-0.90000	-0.62063	-0.80625	-0.99094	-0.71813	-0.33094	[] S
-0.81844	-0.52031	-0.75000	-0.39503	-0.65625	-0.72844	-0.65813	-0.30844	[] E
-0.51844	-0.33281	-0.39000	-0.20625E-01	-0.54375	-0.57844	-0.41813	-0.18094	[] C
0.65625E-02	-0.14531	-0.22500	0.91875E-01	-0.24375	-0.18844	-0.23063	-0.30938E-01	[] T
0.68156	0.64219	0.60000	0.78187	0.39375	0.80906	1.2919	0.11906	[] I
0.90656	0.88219	0.78750	0.69188	1.2187	2.4216	1.0294	0.79406	[] O
-0.84374E-02	-0.25781	0.46500	-0.13313	-0.20625	-0.24094	0.18749E-02	-0.29344	[] N
0.45656	0.45469	0.41250	-0.39563	0.84375	-0.50344	-0.29813	0.23156	[]_14
-0.68625	-0.64594	-0.91031	-0.62156	-0.89250	-1.1559	-0.68906	-0.36188	[] S
-0.64875	-0.53344	-0.62531	-0.39656	-0.74250	-0.74344	-0.76406	-0.33938	[] E
-0.46125	-0.36844	-0.32531	-0.59063E-01	-0.35250	-0.70594	-0.42656	-0.24938	[] C
-0.12375	-0.83438E-01	-0.28781	0.15094	-0.33000	-0.33094	-0.50156	-0.13688	[] T
0.62625	0.55406	0.46219	0.76594	0.34500	1.5441	1.2984	0.88125E-01	[] I
0.71625	0.68156	0.57469	0.61594	1.2825	2.1441	0.88594	0.87563	[] O
0.13875	-0.15844	0.57469	-0.96563E-01	-0.18000	-0.23344	0.23438E-01	-0.18938	[] N
0.43875	0.55406	0.53719	0.35906	0.87000	-0.51844	0.17344	0.31312	[]_15
-0.62156	-0.64031	-0.62906	-0.60469	-0.92344	-0.71250	-0.82031	-0.28219	[] S
-0.58406	-0.35531	-0.63656	-0.41719	-0.84844	-0.71250	-1.0603	-0.29719	[] E
-0.47156	-0.39281	-0.41156	-0.64687E-01	-0.17344	-0.71250	-0.70781	-0.22219	[] C
-0.35906	-0.40313E-01	-0.31406	0.13031	-0.39844	-0.33750	-0.94031	-0.16219	[] T
0.61594	0.31969	0.67594	0.70781	0.31406	1.0800	1.1147	0.28125E-02	[] I
0.48844	0.54469	0.63844	0.48281	1.2891	1.7325	0.67969	0.76781	[] O
0.46594	0.57187E-01	0.36094	-0.46875E-02	-0.13594	-0.45000E-01	0.86719	-0.72188E-01	[] N
0.46594	0.50719	0.31594	-0.22969	0.87656	-0.29250	0.86719	0.26531	[]_16

Appendix III: Deviation values (continued)

-0.12187E-07	0.87188E-07	0.33281E-06	0.19781E-06	0.98031E-06	0.12188E-06	0.13031E-06	0.78750E-07
-0.12187E-07	0.13781E-06	0.33281E-06	0.15469E-06	0.41531E-06	0.31875E-07	0.56313E-07	0.33750E-07
-0.10031E-06	0.25313E-07	0.64688E-07	0.27187E-07	0.60281E-06	0.31875E-07	0.25719E-06	0.93750E-07
-0.12187E-07	0.25031E-06	0.32719E-06	0.13969E-06	0.15281E-06	0.26812E-06	0.10219E-06	0.93750E-07
-0.10031E-06	0.17188E-07	0.13969E-06	0.15469E-06	0.78469E-06	0.15563E-06	0.13031E-06	0.56250E-07
-0.10031E-06	0.12188E-07	0.28969E-06	0.64687E-07	0.78469E-06	0.41813E-06	0.18750E-07	0.18750E-07
-0.10219E-06	0.19969E-06	0.47812E-07	0.14531E-06	0.28128E-08	0.14432E-06	0.20719E-06	0.18750E-07
-0.16219E-06	0.27187E-07	0.10781E-06	0.19781E-06	0.48469E-06	0.51188E-06	0.28031E-06	0.18750E-07
-0.34687E-07	0.17813E-06	0.26250E-07	0.10500E-06	0.41250E-06	0.56250E-07	0.41250E-07	0.10969E-06
-0.72187E-07	0.29062E-06	0.13875E-06	0.14250E-06	0.30000E-06	0.39375E-06	0.44625E-06	0.10031E-06
-0.37219E-06	0.93752E-08	0.43875E-06	0.21750E-06	0.37500E-07	0.20669E-06	0.38625E-06	0.16031E-06
-0.44719E-06	0.17813E-06	0.36375E-06	0.25500E-06	0.41250E-06	0.37125E-06	0.11625E-06	0.16031E-06
-0.19031E-06	0.12188E-06	0.19875E-06	0.12000E-06	0.75000E-06	0.10875E-06	0.22875E-06	0.12188E-07
-0.28125E-08	0.12188E-06	0.17625E-06	0.15000E-07	0.52500E-07	0.93750E-07	0.26625E-06	0.87188E-07
-0.41531E-06	0.12188E-06	0.40875E-06	0.30750E-06	0.26250E-06	0.50625E-06	0.22875E-06	0.87188E-07
-0.31781E-06	0.27188E-06	0.53625E-06	0.30750E-06	0.67500E-06	0.50625E-06	0.26625E-06	0.12469E-06
-0.89531E-07	0.11625E-06	0.10256E-06	0.90469E-07	0.73688E-07	0.88594E-07	0.82031E-07	0.78281E-07
-0.70781E-07	0.52500E-07	0.72656E-07	0.30469E-07	0.36188E-07	0.28594E-07	0.52031E-07	0.52031E-07
-0.42187E-08	0.41250E-07	0.21094E-07	0.22969E-07	0.13125E-08	0.98437E-08	0.11719E-07	0.70312E-08
-0.97969E-07	0.18375E-06	0.17484E-06	0.12703E-06	0.13256E-06	0.10641E-06	0.11673E-06	0.12547E-08
-0.41719E-07	0.33709E-07	0.60937E-08	0.79688E-08	0.61875E-08	0.89062E-08	0.41719E-07	0.32813E-08
-0.13172E-06	0.15375E-06	0.14484E-06	0.14203E-06	0.80062E-07	0.11391E-06	0.97969E-07	0.70781E-07
-0.89531E-07	0.76756E-07	0.72656E-07	0.82969E-07	0.66188E-07	0.81094E-07	0.85781E-07	0.97969E-07
-0.25781E-07	0.15000E-07	0.98906E-07	0.34219E-07	0.31687E-07	0.21094E-07	0.48281E-07	0.22031E-07
-0.56297E-06	0.41625E-06	0.62526E-06	0.51844E-06	0.46294E-06	0.58407E-06	0.48469E-06	0.52730E-06
-0.44297E-06	0.41625E-06	0.26156E-06	0.15094E-06	0.42544E-06	0.56527E-06	0.39099E-06	0.45240E-06
-0.44297E-06	0.31875E-06	0.35156E-06	0.45464E-06	0.46294E-06	0.45657E-06	0.30839E-06	0.37230E-06
-0.30797E-06	0.26669E-06	0.31788E-06	0.34594E-06	0.35044E-06	0.35157E-06	0.28969E-06	0.28350E-06
-0.43453E-06	0.39375E-06	0.41344E-06	0.45556E-06	0.45581E-06	0.54093E-06	0.32158E-06	0.41019E-06
-0.27703E-06	0.35639E-06	0.30094E-06	0.44531E-06	0.44831E-06	0.40593E-06	0.39531E-06	0.39148E-06
-0.59578E-06	0.25875E-06	0.33844E-06	0.42656E-06	0.36131E-06	0.47188E-06	0.43406E-06	0.37269E-06
-0.58453E-06	0.40875E-06	0.50344E-06	0.50156E-06	0.43631E-06	0.56343E-06	0.42281E-06	0.46540E-06
-0.29718E-06	0.24656E-06	0.21469E-06	0.38906E-06	0.18094E-06	0.31171E-06	0.29783E-06	0.33843E-06
-0.24097E-06	0.17156E-06	0.11339E-06	0.27656E-06	0.21844E-06	0.25551E-06	0.25406E-06	0.33042E-06
-0.14717E-06	0.21563E-07	0.85312E-07	0.12656E-06	0.14344E-06	0.49212E-07	0.29155E-06	0.14392E-06
-0.14129E-07	0.15937E-07	0.32812E-07	0.77633E-07	0.14344E-06	0.10171E-06	0.32850E-07	0.30526E-07
-0.15282E-06	0.11344E-06	0.45988E-07	0.29344E-06	0.11906E-06	0.17579E-06	0.12095E-06	0.11947E-06
-0.28782E-06	0.12844E-06	0.12281E-06	0.60937E-07	0.26906E-06	0.63287E-07	0.15845E-06	0.17579E-06
-0.21529E-07	0.12844E-06	0.12281E-06	0.26714E-06	0.17906E-06	0.28829E-06	0.27845E-06	0.23207E-06
-0.20902E-06	0.53437E-07	0.10313E-07	0.24844E-06	0.11906E-06	0.19079E-06	0.27845E-06	0.30697E-06
-0.10781E-06	0.53437E-07	0.32450E-06	0.32450E-06	0.32812E-06	0.30425E-06	0.53781E-06	0.18219E-06
-0.79690E-07	0.48794E-06	0.13000E-07	0.46877E-07	0.14062E-06	0.35025E-06	0.23781E-06	0.28127E-07
-0.49219E-06	0.11706E-06	0.13700E-06	0.37875E-06	0.46874E-07	0.22025E-06	0.16281E-06	0.84374E-07
-0.79690E-07	0.56706E-06	0.13700E-06	0.57188E-06	0.38437E-06	0.40775E-06	0.84169E-06	0.46313E-06
-0.10781E-06	0.29494E-06	0.21200E-06	0.56624E-07	0.84377E-07	0.72425E-06	0.13311E-06	0.34313E-06
-0.46875E-08	0.26706E-06	0.50499E-07	0.27188E-06	0.12188E-06	0.31225E-06	0.13311E-06	0.29063E-06
-0.44531E-06	0.66994E-06	0.41100E-06	0.56624E-07	0.17813E-06	0.40025E-06	0.88312E-07	0.15937E-06
-0.46875E-08	0.45657E-08	0.33600E-06	0.55312E-06	0.93733E-08	0.66275E-06	0.21169E-06	0.14062E-06

Appendix IV: Representative solutions (analyzed data)

This appendix consists of representative factor loadings for factor analysis solutions of one through four factors. It is ordered so that the six-subject solutions appear first, followed by the four-subject solutions. Within each of these divisions, the sixteen-section solutions occur first, followed by the twelve-section solutions. In one case (6 speakers, 16 sections, 4 factors) there are two solutions presented. This is a case of a multiple solution; the solution presented second represents a single solution in disagreement with five matching solutions (the first representation).

The loadings appear in tabular form on each left-hand page; the respective analogical counterparts are on the facing pages. In these displays zero is indicated for the speaker and vowel loadings as a cipher and for the vocal tract loadings as a thin center line. By convention I have given positive values to the majority of the speakers and arranged the vowel loadings so that [i] is always positive. The scales are purposely not calibrated since it is only the relative magnitude and order of the loadings that concern us.

Table A1. One-factor unique solution (6 speakers, 16 sections). Correlation squared= 0.6237559.

MODE A: SPEAKERS

1 0.3061
 2 0.4135
 3 0.2935
 4 0.3712
 5 0.5297
 6 0.3122

MODE B: VOWELS

1 [i] 1.586
 2 [ɪ] 0.8716
 3 [e] 0.4435
 4 [ɛ] -0.2323
 5 [o] -0.7891
 6 [ɔ] -1.728
 7 [u] 0.5769
 8 [ʊ] -0.7286

MODE C: VOCAL TRACT SECTIONS

1 0.7545E-01
 2 0.2558
 3 0.6014
 4 0.7947
 5 1.462
 6 1.415
 7 1.278
 8 1.053
 9 0.5859
 10 0.8472E-01
 11 -0.5089
 12 -0.9506
 13 -1.281
 14 -1.367
 15 -1.293
 16 -1.166

Table A2. Two-factor unique solution (6 speakers, 16 sections). Correlation squared= 0.7396172.

MODE A: SPEAKERS

1-0.1806 0.2948
 2-0.3755 0.1650
 3-0.1460 0.3253
 4-0.3312 0.9029E-01
 5-0.4601 0.2316
 6-0.3424 0.5610E-01

MODE B: VOWELS

1 [i] -1.695 -1.003
 2 [ɪ] -0.5934 -1.318
 3 [e] -0.2517 -0.8469
 4 [ɛ] 0.5993 -0.6633
 5 [o] 0.5972 0.9665
 6 [ɔ] 1.604 1.489
 7 [u] -0.9632 0.6322
 8 [ʊ] 0.7030 0.7419

MODE C: VOCAL TRACT SECTIONS

1 0.5495 0.9553
 2 0.6354 0.6509
 3 0.9669 0.4658
 4 1.322 0.6622
 5 1.853 0.1165
 6 1.698 -0.5516E-01
 7 1.451 -0.2018
 8 1.163 -0.3043
 9 0.5335 -0.3399
 10 0.1422 0.1153
 11 -0.3089 0.6372
 12 -0.6175 1.084
 13 -0.7654 1.629
 14 -0.7709 1.840
 15 -0.7388 1.728
 16 -0.5711 1.767

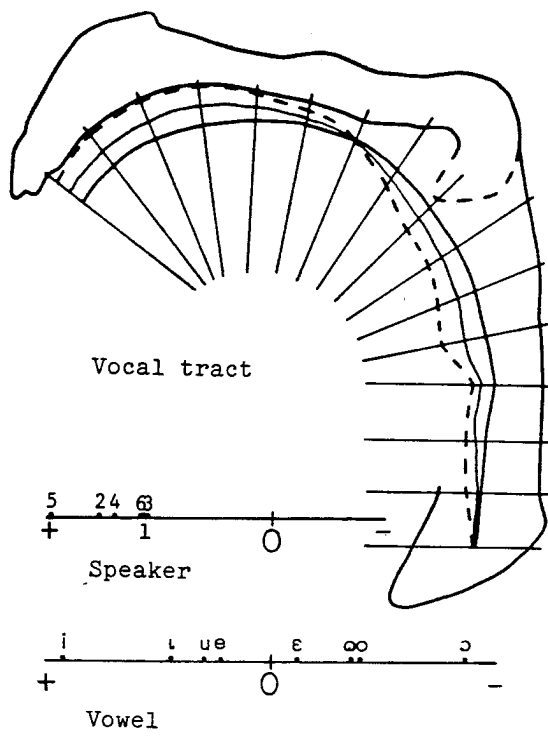

Figure A1. One-factor unique solution (6 speakers, 16 sections)

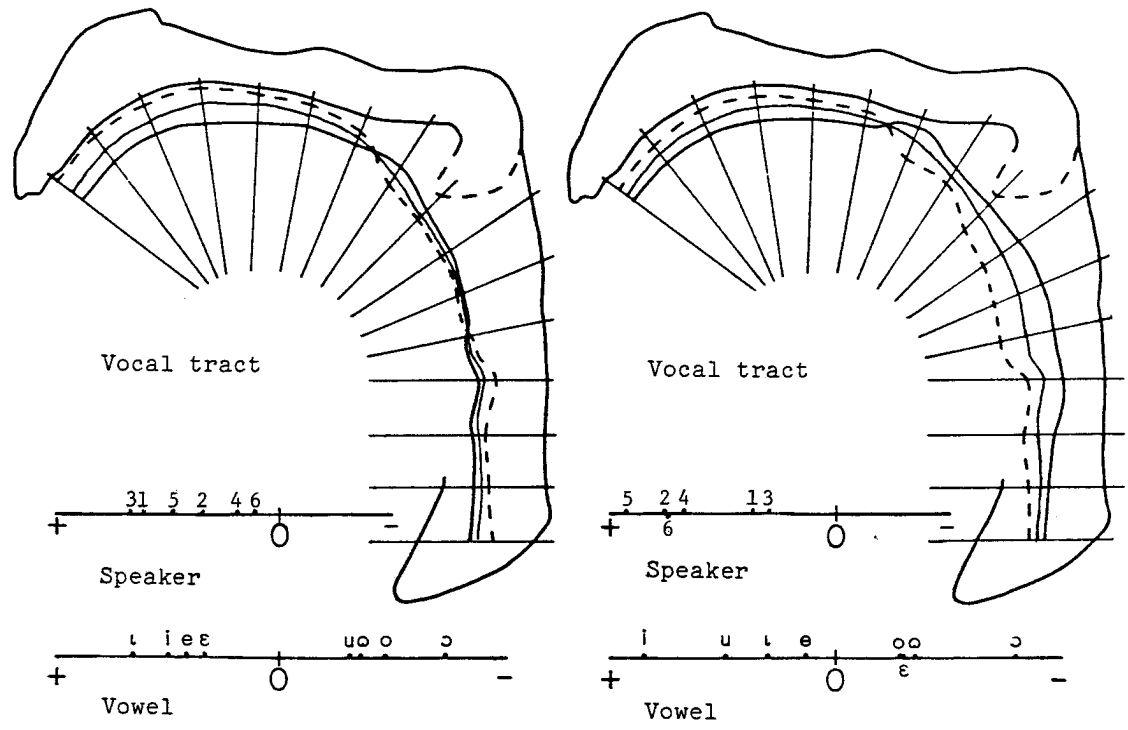

Figure A2. Two-factor unique solution (6 speakers, 16 sections)

Table A3. Three-factor unique solution (6 speakers, 16 sections).
 Correlation squared= 0.8246202.

MODE A: SPEAKERS

1	-1.616	-0.8625	1.029
2	-0.7367	0.2435	1.326
3	-1.443	-0.3236	0.4463
4	0.3714	2.078	0.4038E-01
5	-0.7645	0.7943	1.233
6	-0.2034	0.3768	1.210

MODE B: VOWELS

1	[i]	-1.167	1.609	-1.332
2	[v]	-1.365	1.224	0.1300
3	[e]	-0.7750	0.4412	-0.3766E-01
4	[ε]	-0.4641	-0.2662	0.7943
5	[o]	0.9624	-1.026	0.1413
6	[ɔ]	1.455	-1.583	1.285
7	[u]	0.6386	-0.1405	-1.799
8	[ɔ]	0.7141	-0.2582	0.8178

MODE C: VOCAL TRACT SECTIONS

1	-0.1751	-0.1070E-04	-0.1745
2	-0.9694E-01	0.7847E-02	-0.2188
3	-0.4952E-02	0.3692E-01	-0.2993
4	-0.2145E-01	0.8871E-01	-0.4183
5	0.1784	0.3499	-0.4407
6	0.2118	0.3994	-0.3530
7	0.2246	0.4199	-0.2456
8	0.1966	0.3533	-0.2162
9	0.1402	0.2744	-0.4081E-01
10	-0.7560E-02	0.1874	0.5999E-01
11	-0.1699	0.1899E-01	0.1454
12	-0.3034	-0.1229	0.1903
13	-0.4494	-0.2091	0.1992
14	-0.5031	-0.2585	0.1729
15	-0.4798	-0.2705	0.1446
16	-0.4729	-0.2675	0.8530E-01

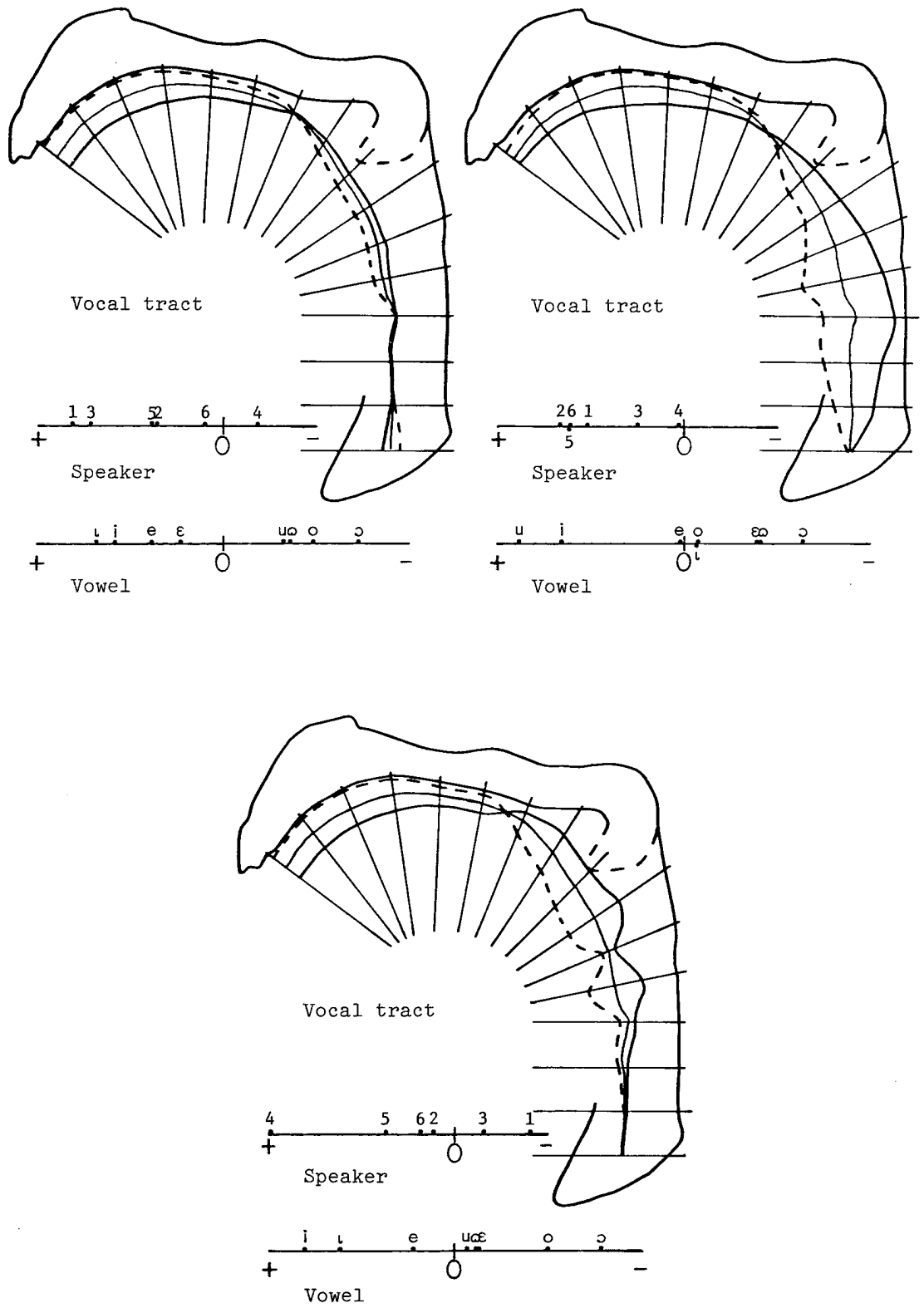

Figure A3. Three-factor unique solution (6 speakers, 16 sections)

Table A4. Four-factor unique solution (6 speakers, 16 sections).
 Correlation squared= 0.8787379.

MODE A: SPEAKERS

1-0.1316	0.7352	-1.275	1.035
2-0.7614	1.400	0.8192	0.8027
3-0.5260	-0.3297	1.417	1.121
4 -1.710	-1.094	0.4977	1.299
5 -1.284	1.092	1.119	0.9901
6-0.7437	1.000	0.4428	0.5993

MODE B: VOWELS

1 [i] -1.804	0.9520	-0.5513	1.055
2 [ɪ] -0.9672	-0.2891	-1.309	-0.1456E-02
3 [e] -0.3060	0.2264	-0.8623	-0.1280
4 [ɛ] 0.5748	-0.2427	-1.116	-1.129
5 [o] 0.8553	0.1797	0.7461	-0.3824
6 [ɔ] 1.519	-0.9062	0.6851	-1.590
7 [u] -0.3455	1.778	1.395	1.613
8 [ʊ] 0.4743	-1.699	1.012	0.5647

MODE C: VOCAL TRACT SECTIONS

1 0.1799	0.1074	0.2301	-0.1327
2 0.1142	0.1615	0.1336	-0.9067E-02
3 0.8017E-01	0.1717	0.3575E-01	0.1625
4 0.1003	0.2341	0.5035E-01	0.2316
5 0.4097	0.2777	-0.1115E-01	0.1569
6 0.4821	0.2364	-0.1100E-01	0.4908E-01
7 0.5310	0.1688	-0.3587E-02	-0.6731E-01
8 0.4438	0.1588	-0.2773E-01	-0.7451E-01
9 0.3603	0.5449E-01	0.1879E-02	-0.1661
10 0.3555	0.1352E-01	0.1340	-0.3506
11 0.2250	-0.5968E-01	0.2426	-0.4127
12 0.1113	-0.1094	0.3355	-0.4341
13 0.4221E-01	-0.1533	0.4614	-0.4210
14 -0.2790E-01	-0.1569	0.4910	-0.3487
15 -0.9136E-01	-0.1533	0.4462	-0.2488
16 -0.1052	-0.1230	0.4279	-0.1880

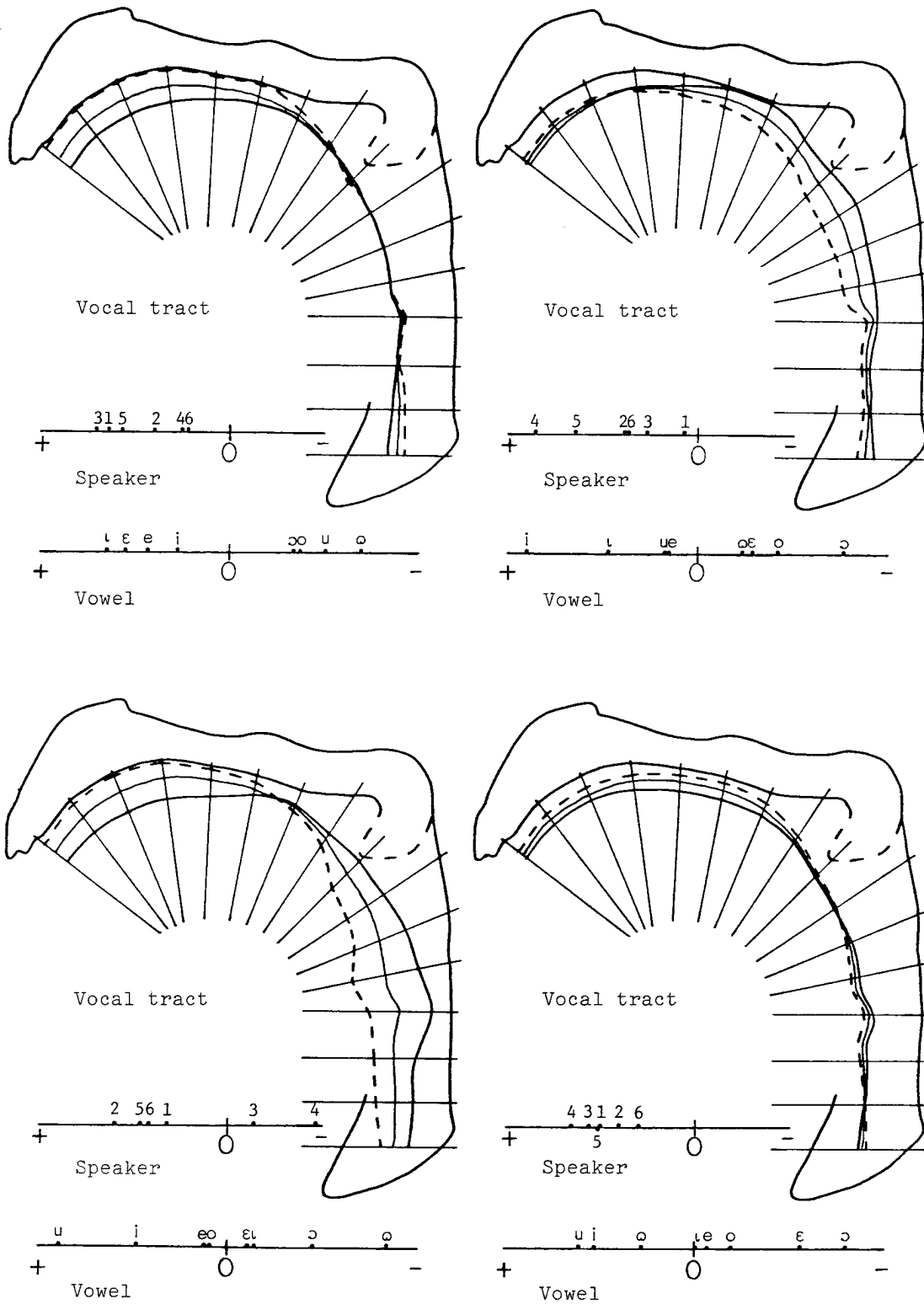

Figure A4. Four-factor unique solution (6 speakers, 16 sections)

Table A5. Four-factor nonunique solution (6 speakers, 16 solutions).
Correlation squared= 0.8756670.

MODE A: SPEAKERS

1	0.2435	1.394	-1.373	0.3467
2	0.5281	1.071	-1.090	1.264
3	0.5306	1.023	-0.9730	0.1703
4	-2.203	0.7734E-01	-0.2479	0.6007
5	0.4463	1.173	-1.131	1.596
6	0.5173	0.6851	-0.7185	1.159

MODE B: VOWELS

1	[i]	-1.281	-0.6449	-0.4319	-1.305
2	[ɪ]	-1.295	-1.401	-1.319	-0.7130
3	[e]	-0.3300	-0.7393	-0.6529	-0.2873
4	[ɛ]	0.2731E-01	-0.9644	-1.059	0.4949
5	[o]	1.408	0.7395	0.6900	0.6536
6	[ɔ]	1.193	0.5863	0.1977	1.452
7	[u]	0.8895	1.611	1.876	-0.7191
8	[ʊ]	-0.6123	0.7639	0.7003	0.9249

MODE C: VOCAL TRACT SECTIONS

1	-0.6653E-01	0.7797	0.5792	-0.2212
2	0.1011E-01	0.1670	0.9377E-02	-0.1898
3	0.4124E-01	-0.4869	-0.6048	-0.2031
4	0.1333	-0.8958	-1.077	-0.2452
5	0.2551	-0.7943	-0.3603	-0.4808
6	0.2503	-0.3341	-0.3897	-0.5053
7	0.2105	0.1304	0.1786	-0.5137
8	0.2074	0.1017	0.1473	-0.4225
9	0.1632	0.5044	0.5872	-0.2792
10	0.5012E-01	1.356	1.383	-0.2418
11	-0.8970E-01	1.819	1.760	-0.1160
12	-0.1973	-2.090	1.946	-0.1480E-01
13	-0.2275	2.192	1.918	0.7231E-01
14	-0.2247	1.953	1.621	0.1308
15	-0.1983	1.543	1.211	0.1734
16	-0.1849	1.278	0.9326	0.1630

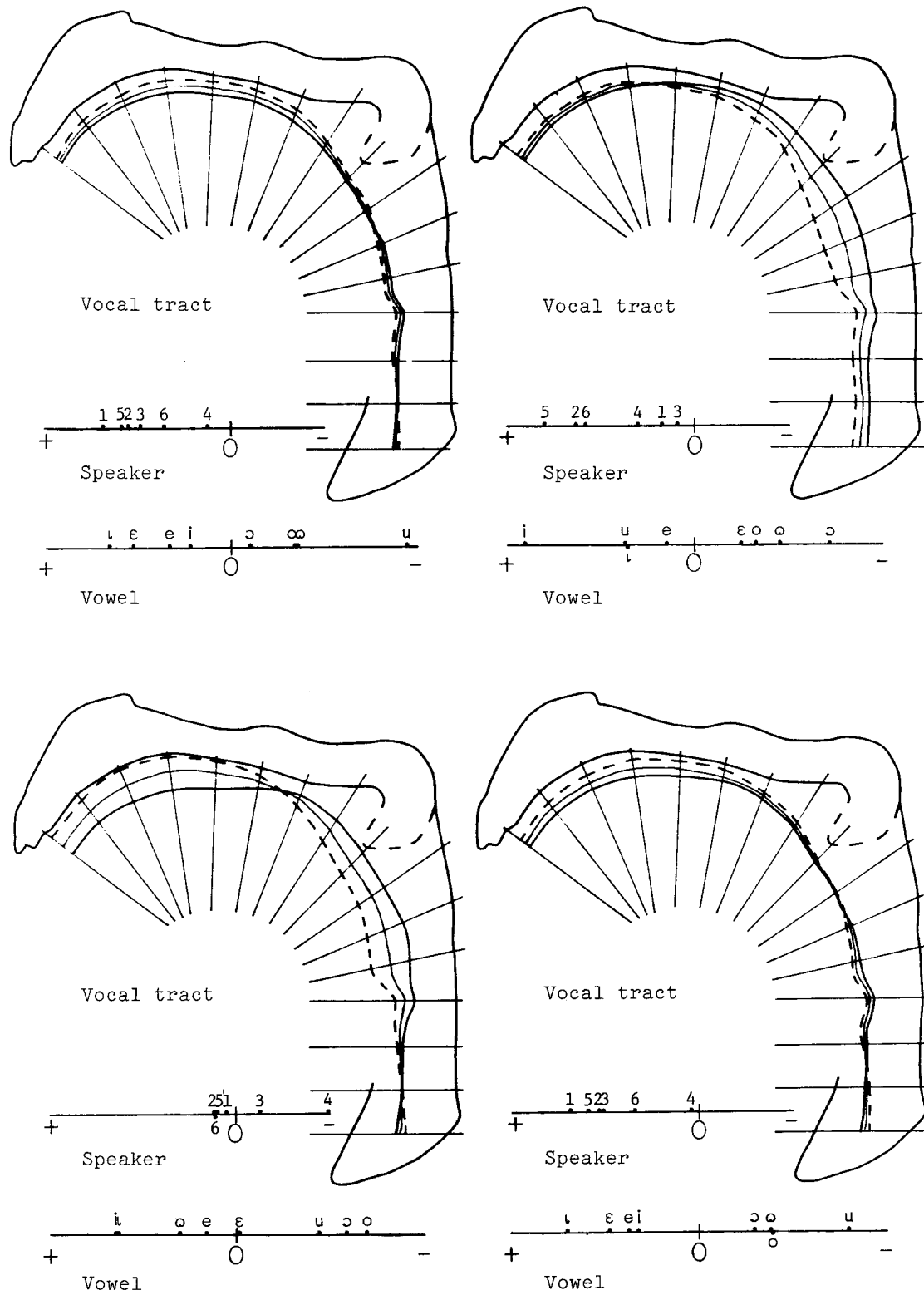

Figure A5. Four-factor nonunique solution (6 speakers, 16 sections)

Table A6. One-factor unique solution (6 speakers, 12 sections).
Correlation squared= 0.6965267

MODE A: SPEAKERS

1 0.8115
2 1.052
3 0.8308
4 1.005
5 1.410
6 0.7382

MODE B: VOWELS

1 [i] -1.563
2 [u] -0.9599
3 [e] -0.4888
4 [ɛ] 0.1444
5 [o] 0.8436
6 [ɔ] 1.716
7 [u] -0.4262
8 [ɔ] 0.7338

MODE C: VOCAL TRACT SECTIONS

1-0.5393
2-0.5282
3-0.4836
4-0.3983
5-0.2301
6-0.3909E-01
7 0.1904
8 0.3629
9 0.4934
10 0.5301
11 0.5022
12 0.4575

Table A7. Two-factor unique solution (6 speakers, 12 sections).
Correlation squared= 0.8031501

MODE A: SPEAKERS

1 -1.482 -0.1855
2-0.8241 -1.018
3 -1.413 -0.3044
4-0.1817 -1.351
5-0.9789 -1.494
6-0.3709 -0.8821

MODE B: VOWELS

1 [i] 1.163 1.768
2 [u] 1.111 0.8748
3 [e] 0.8045 0.2983
4 [ɛ] 0.3781 -0.5351
5 [o] -0.9002 -0.7434
6 [ɔ] -1.803 -1.528
7 [u] -0.1694E-02 0.5782
8 [ɔ] -0.7502 -0.7134

MODE C: VOCAL TRACT SECTIONS

1-0.5508E-01-0.5378
2-0.4066E-01-0.5401
3-0.1631E-01-0.5150
4-0.2829E-01-0.4163
5 0.4494E-02-0.2543
6 0.1351 -0.1626
7 0.2485 -0.1536E-01
8 0.3275 0.1010
9 0.4210 0.1643
10 0.4343 0.1949
11 0.3842 0.2110
12 0.3661 0.1836

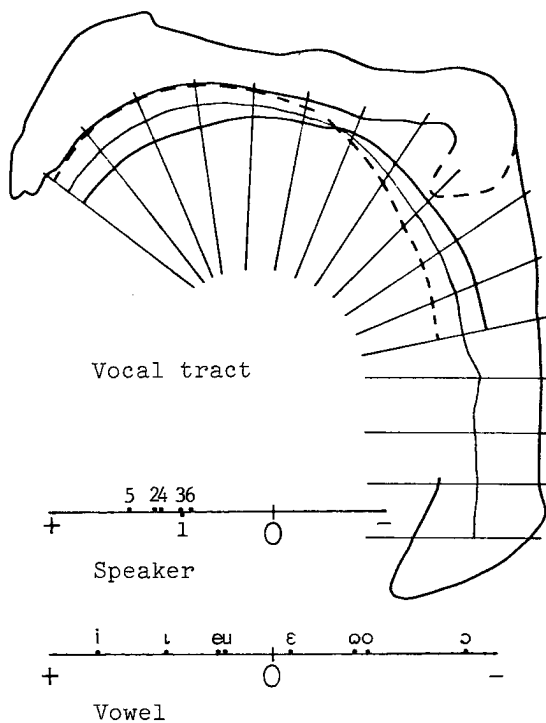

Figure A6. One-factor unique solution (6 speakers, 12 sections)

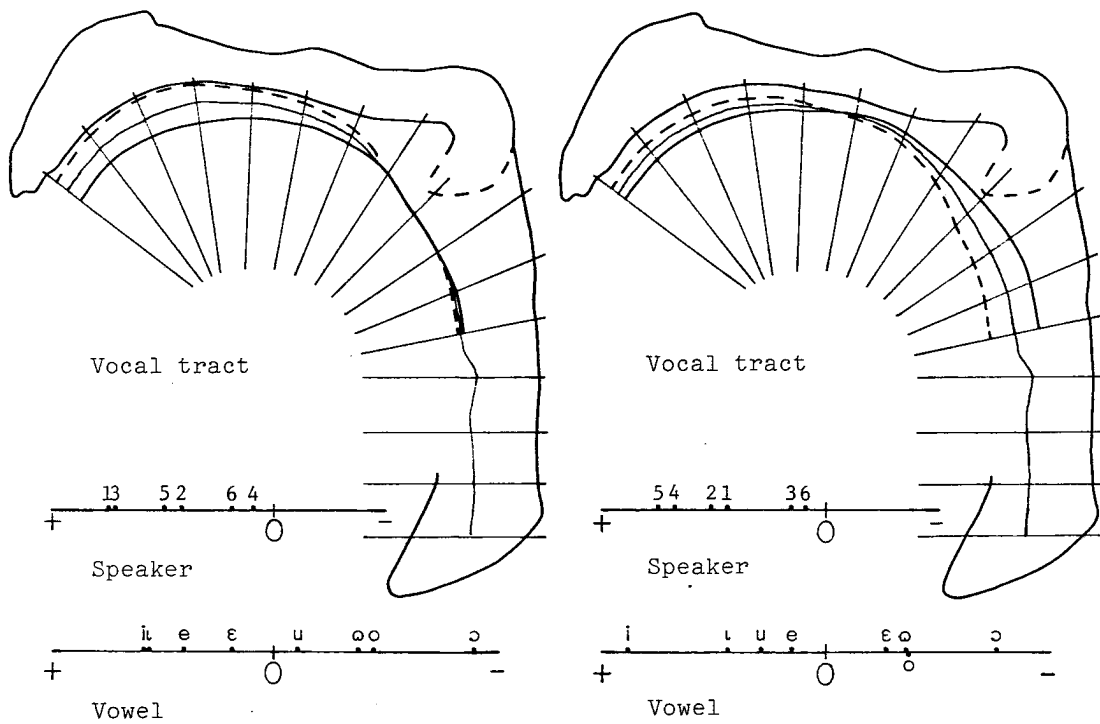

Figure A7. Two-factor unique solution (6 speakers, 12 sections)

Table A8. Three-factor unique solution (6 speakers, 12 sections).
 Correlation squared= 0.8695671.

MODE A: SPEAKERS

1	0.1528	1.567	0.4136
2	0.7743	0.6961	1.206
3	0.4332	1.465	0.1167
4	1.886	-0.4419	0.5838
5	1.138	0.8072	1.675
6	0.5828	0.2600	1.102

MODE B: VOWELS

1	[i]	-1.439	1.089	-0.9186
2	[ɪ]	-1.305	1.217	0.2420
3	[e]	-0.3568	0.8724	-0.8401E-01
4	[ɛ]	-0.3310E-01	0.5163	0.7661
5	[o]	1.418	-0.9182	-0.5264
6	[ɔ]	1.237	-1.650	1.030
7	[u]	0.7095	-0.3304	-1.841
8	[ʊ]	-0.2299	-0.7943	1.332

MODE C: VOCAL TRACT SECTIONS

1	-0.3748	0.6239E-01	-0.4640
2	-0.4128	0.4968E-01	-0.4028
3	-0.4255	0.2874E-01	-0.3135
4	-0.3447	0.3440E-01	-0.2774
5	-0.2758	-0.1226E-01	-0.9549E-01
6	-0.1678	-0.1244	-0.3808E-02
7	0.1166E-01	-0.2111	0.9357E-01
8	0.1538	-0.2744	0.1598
9	0.2347	-0.3693	0.1923
10	0.2788	-0.3876	0.1829
11	0.2769	-0.3528	0.1749
12	0.2587	-0.3389	0.1393

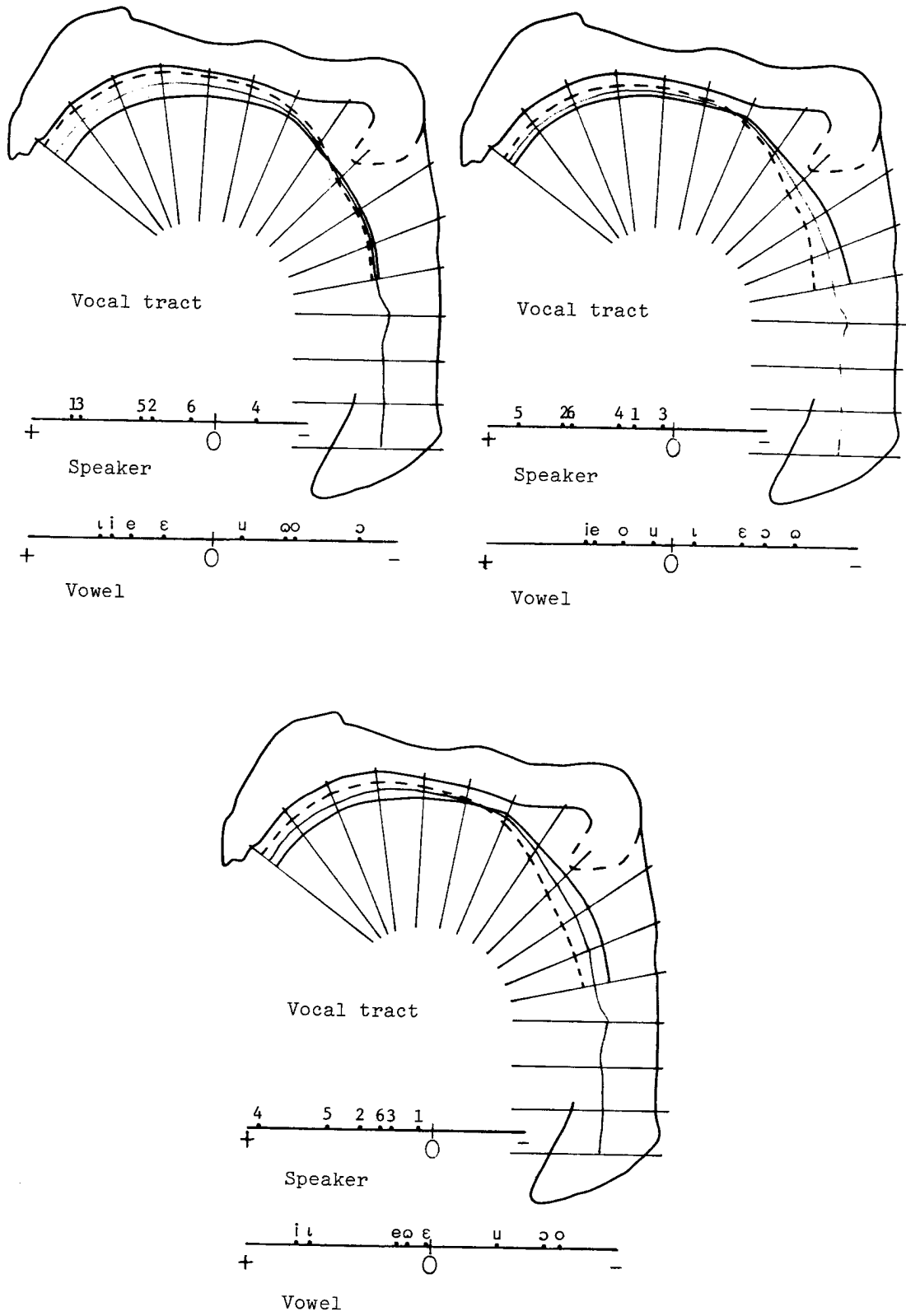

Figure A8. Three-factor unique solution (6 speakers, 12 sections)

Table A9. Four-factor unique solution (6 speakers, 12 sections).
 Correlation squared= 0.9311647.

MODE A: SPEAKERS

1	0.2604	-1.276	1.256	0.2754
2	0.5737	-1.038	1.059	1.113
3	0.4965	-1.025	0.8285	0.3198
4	-2.043	-0.1948	0.6342	0.9648
5	0.9133	-1.337	1.311	1.646
6	0.5897	-0.6447	0.7044	0.9723

MODE B: VOWELS

1	[i]	-1.002	-0.8042	-0.1393E-01	1.736
2	[ɪ]	-1.190	-1.276	-0.8791	0.7774
3	[e]	-0.2208	-0.6713	-0.3536	0.2763
4	[ɛ]	-0.1634	-1.140	-1.476	-0.6809
5	[o]	1.560	0.9636	0.5868	-0.6551
6	[ɔ]	0.7905	0.7971	-0.4522	-1.499
7	[u]	1.213	1.332	2.010	0.7851
8	[ʊ]	-0.9876	0.7986	0.5806	-0.7411

MODE C: VOCAL TRACT SECTIONS

1	0.2103	0.2234	0.2776	0.4687
2	0.1981	0.1005	0.7789E-01	0.5242
3	0.1545	-0.5104E-01	-0.1409	0.5585
4	0.1557	-0.3964E-01	-0.1256	0.4616
5	0.1293	-0.1517	-0.2813	0.3317
6	0.3805E-01	-0.4594	-0.5490	0.3109
7	-0.7878E-01	-0.6597	-0.6486	0.1899
8	-0.1702	-0.7970	-0.6845	0.8809E-01
9	-0.1991	-0.9114	-0.6603	0.9533E-02
10	-0.1944	-0.8648	-0.5414	-0.5927E-01
11	-0.1715	-0.7250	-0.3908	-0.1172
12	-0.1584	-0.6258	-0.2722	-0.1287

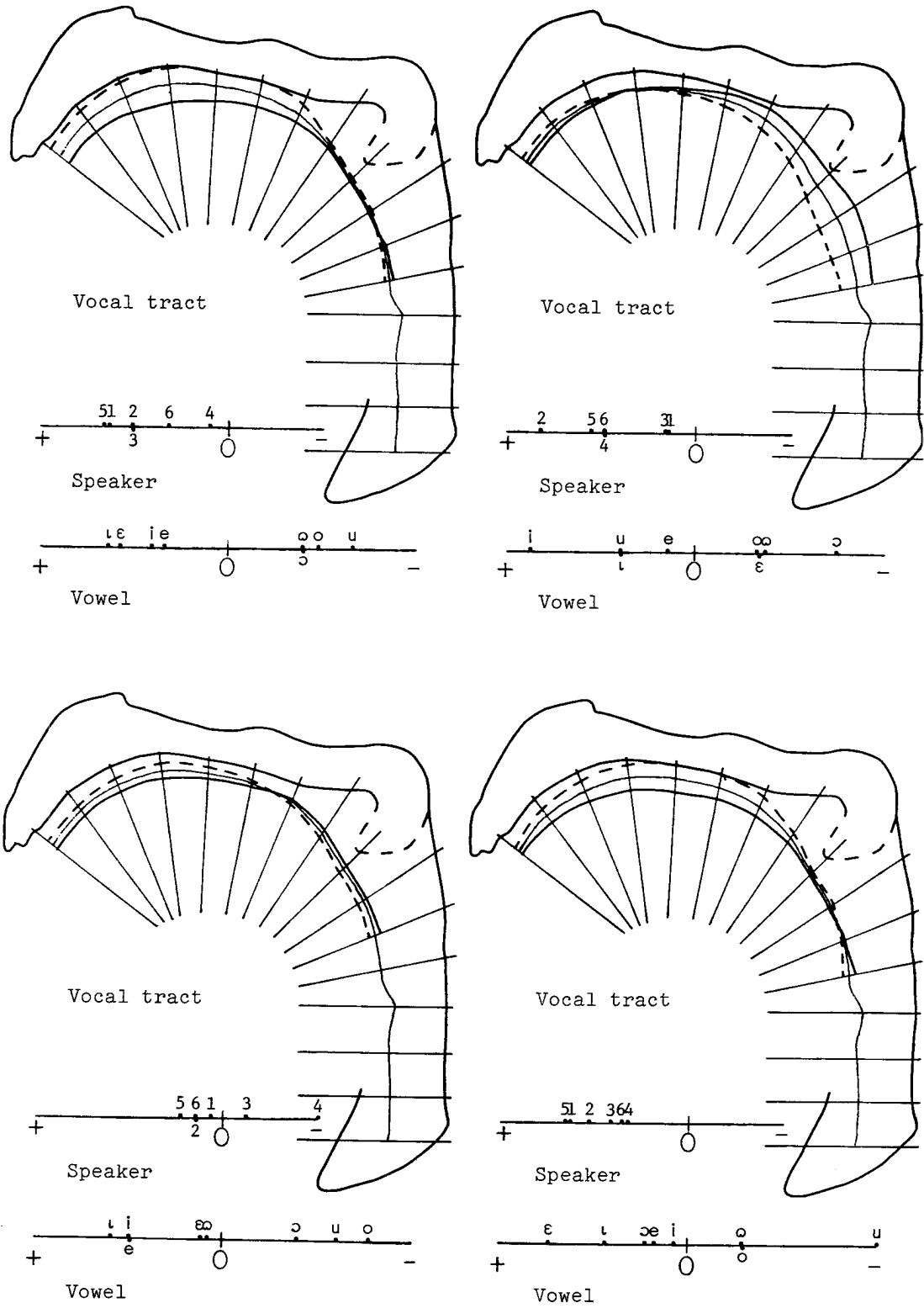

Figure A9. Four-factor unique solution (6 speakers, 12 sections)

Table A10. One-factor unique solution (4 speakers, 16 sections). Correlation squared= 0.6978931.

MODE A: SPEAKERS

1-0.7474
2 -1.043
3 -1.307
4-0.8036

MODE B: VOWELS

1 [i] 1.507
2 [ɪ] 0.7102
3 [e] 0.4527
4 [ɛ] -0.2442
5 [o] -0.5635
6 [ɔ] -1.675
7 [u] 0.8609
8 [ʊ] -1.048

MODE C: VOCAL TRACT SECTIONS

1-0.9475E-01
2-0.1643
3-0.2967
4-0.4001
5-0.6223
6-0.5833
7-0.5088
8-0.3971
9-0.1837
10-0.9728E-02
11 0.2071
12 0.3634
13 0.5048
14 0.5427
15 0.5198
16 0.4588

Table A11. Two-factor unique solution. (4 speakers, 16 sections). Correlation squared= 0.8169475.

MODE A: SPEAKERS

1 0.5060 1.235
2 1.095 0.8628
3 1.218 1.256
4 1.029 0.3914

MODE B: VOWELS

1 [i] -1.617 -0.9406
2 [ɪ] -0.2048 -1.363
3 [e] -0.1712 -0.8211
4 [ɛ] 0.6963 -0.5682
5 [o] 0.3451 0.8017
6 [ɔ] 1.399 1.625
7 [u] -1.376 0.3359
8 [ʊ] 0.9287 0.9299

MODE C: VOCAL TRACT SECTIONS

1-0.2452 0.1854
2-0.2967 0.1457
3-0.3716 0.6008E-01
4-0.5177 0.9198E-01
5-0.6165 -0.6365E-01
6-0.5213 -0.1243
7-0.3966 -0.1783
8-0.3758 -0.7650E-01
9-0.1208 -0.9842E-01
10 0.8413E-02 -0.2149E-01
11 0.1219 0.1232
12 0.1918 0.2398
13 0.2211 0.3896
14 0.2027 0.4629
15 0.1863 0.4499
16 0.1228 0.4526

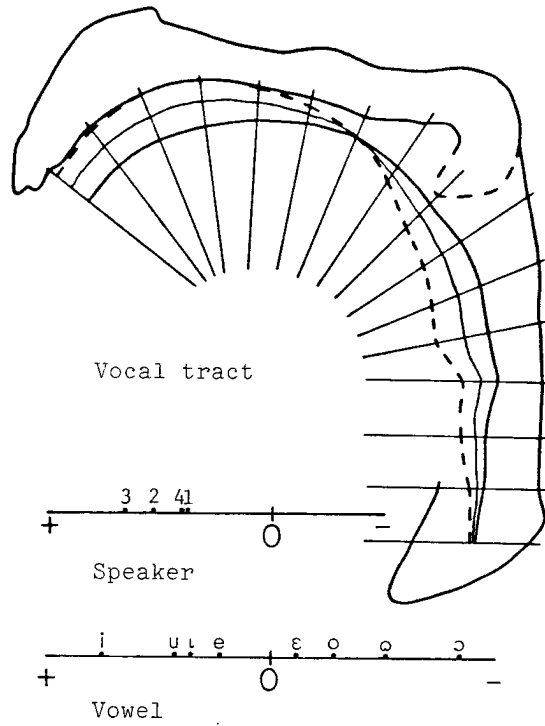

Figure A10. One-factor unique solution (4 speakers, 16 sections)

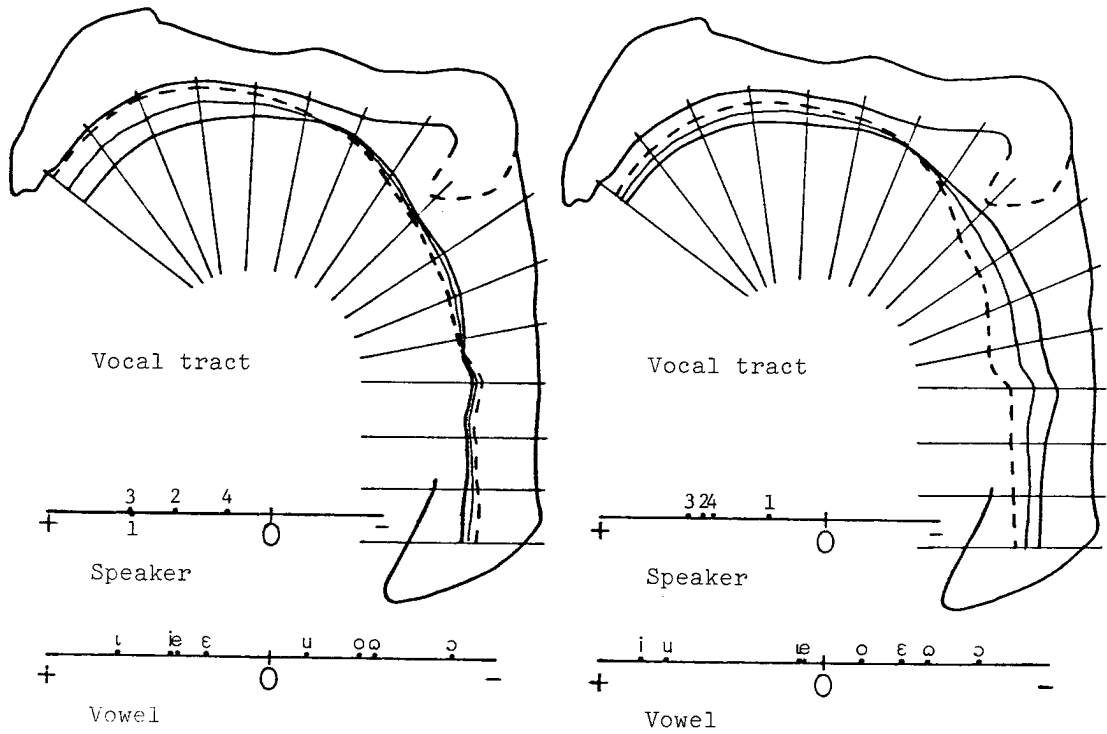

Figure A11. Two-factor unique solution (4 speakers, 16 sections)

Table A12. Three-factor unique solution (4 speakers, 16 sections).
 Correlation squared= 0.8827122.

MODE A: SPEAKERS

1	-1.322	-1.129	0.7277E-01
2	-0.8531	-1.065	-1.025
3	-1.167	-0.8041	-1.419
4	-0.4021	-0.9722	-0.9637

MODE B: VOWELS

1	[i]	1.011	-1.150	-1.834
2	[ɪ]	1.248	0.2711	-0.5325
3	[e]	0.8313	-0.1248	-0.1799
4	[ɛ]	0.4155	0.9255	0.6176
5	[o]	-0.7832	0.1251	0.4356
6	[ɔ]	-1.753	1.324	1.267
7	[u]	-0.3624E-01	-1.915	-0.9151
8	[ʊ]	-0.9316	0.5439	1.143

MODE C: VOCAL TRACT SECTIONS

1	0.1730	0.1916	0.9550E-01
2	0.1247	0.2024	0.1306
3	0.6831E-02	0.2959	0.9171E-01
4	0.1486E-01	0.4262	0.1152
5	-0.1037	0.2732	0.3816
6	-0.1329	0.1186	0.4375
7	-0.1516	-0.3157E-01	0.4636
8	-0.5400E-01	0.5698E-02	0.4053
9	-0.4961E-01	-0.1455	0.2889
10	0.5011E-01	-0.2327	0.2538
11	0.2002	-0.2467	0.1595
12	0.3081	-0.2221	0.6233E-01
13	0.4460	-0.1436	-0.3530E-01
14	0.5021	-0.5990E-01	-0.9739E-01
15	0.4673	0.1614E-01	-0.1650
16	0.4477	0.1210	-0.2055

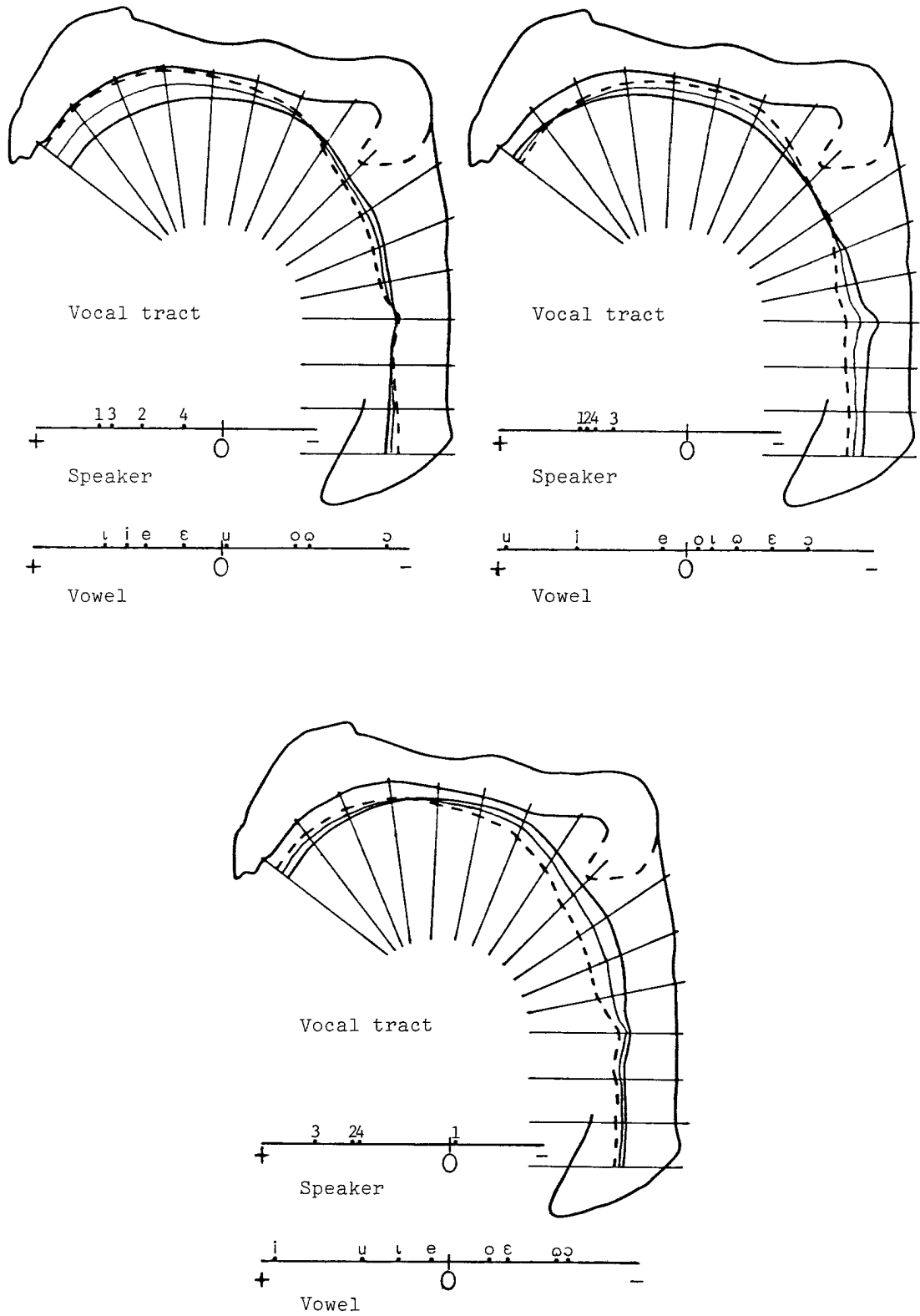

Figure A12. Three-factor unique solution (4 speakers, 16 sections)

Table A13. Four-factor unique solution (4 speakers, 16 sections).
 Correlation squared= 0.9076660.

MODE A: SPEAKERS

1	-0.6013	1.396	-1.455	0.8990
2	0.7099	0.8392	-0.8016	1.140
3	1.684	1.135	-1.106	0.6146
4	0.5450	0.2409	-0.1324	1.231

MODE B: VOWELS

1	[i]	1.957	0.8083	0.6712	1.539
2	[t]	0.6326	0.8800	0.7816	-0.1396
3	[e]	0.1492	0.9015	0.9258	0.5103E-01
4	[ɛ]	-0.8805	-0.2755	-0.4274	-0.6469
5	[o]	-0.2992	-0.4114	-0.2948	-0.3693
6	[ɔ]	-1.169	-2.001	-2.019	-1.243
7	[u]	0.6532	0.9182	1.097	1.665
8	[ɑ]	-1.044	-0.8160	-0.7301	-0.8583

MODE C: VOCAL TRACT SECTIONS

1	0.3621E-01	-0.6381	-0.4431	0.3057
2	0.7947E-01	-0.7407	-0.6180	0.3007
3	0.2570E-01	-0.1542	-0.1485	0.3608
4	0.6514E-01	-0.6409	-0.6547	0.4775
5	0.3119	-0.6022E-01	-0.2620	0.3126
6	0.3324	0.6765	0.4839	0.2079
7	0.3310	1.213	1.034	0.9683E-01
8	0.2525	1.049	1.015	0.1903
9	0.1539	1.244	1.239	0.1653E-01
10	0.1250	0.9231	1.033	-0.4511E-01
11	0.7518E-01	0.1186	0.3808	-0.7024E-01
12	0.2557E-01	-0.6334	-0.2711	-0.7513E-01
13	0.8134E-02	-1.810	-1.343	-0.5666E-01
14	-0.8250E-02	-2.470	-1.972	-0.1622E-01
15	-0.4532E-01	-2.646	-2.196	0.1052E-01
16	-0.7274E-01	-2.852	-2.437	0.8434E-01

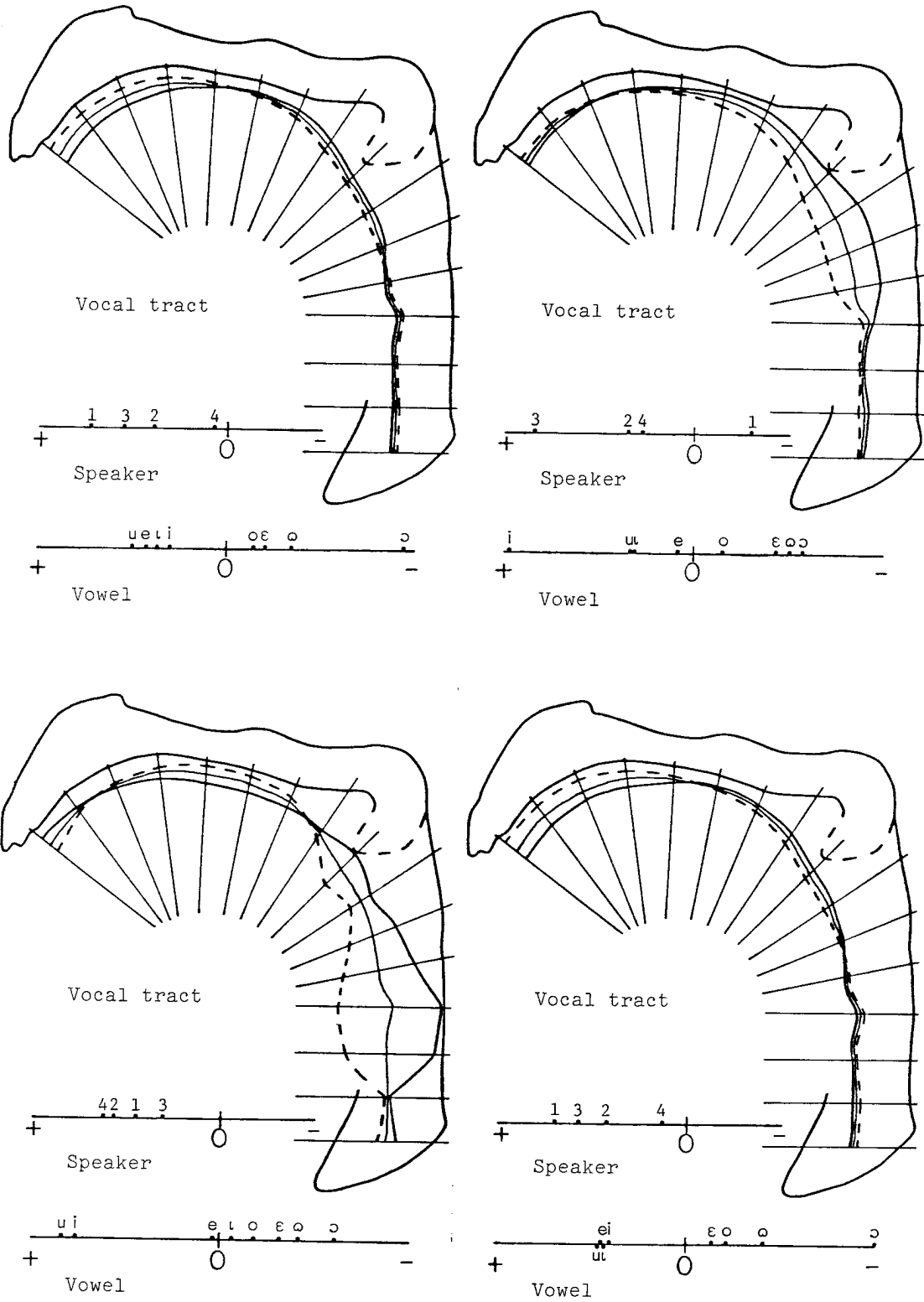

Figure A13. Four-factor unique solution (4 speakers, 16 sections)

Table A14. One-factor unique solution (4 speakers, 12 sections).
Correlation squared= 0.7693765.

MODE A: SPEAKERS

1-0.7707
2 -1.010
3 -1.366
4-0.7209

MODE B: VOWELS

1 [i] 1.471
2 [ɪ] 0.8532
3 [e] 0.5135
4 [ɛ] -0.1482
5 [o] -0.6081
6 [ɔ] -1.699
7 [u] 0.6722
8 [ʊ] -1.055

MODE C: VOCAL TRACT SECTIONS

1-0.6019
2-0.5721
3-0.5083
4-0.3882
5-0.1882
6-0.1559E-01
7 0.2050
8 0.3660
9 0.5150
10 0.5588
11 0.5376
12 0.4811

Table A15. Two-factor unique solution (4 speakers, 12 sections).
Correlation squared= 0.8680746.

MODE A: SPEAKERS

1 1.252 -0.6290E-01
2 0.9138 0.9824
3 1.158 1.466
4 0.5058 0.9394

MODE B: VOWELS

1 [i] -1.154 -1.801
2 [ɪ] -1.039 -0.5115
3 [e] -0.7598 -0.1550
4 [ɛ] -0.2352 0.8014
5 [o] 0.7509 0.3534
6 [ɔ] 1.839 1.255
7 [u] -0.3467 -1.002
8 [ʊ] 0.9444 1.060

MODE C: VOCAL TRACT SECTIONS

1-0.1815 -0.5093
2-0.1835 -0.4750
3-0.1689 -0.4179
4-0.6293E-01-0.3984
5-0.2701E-01-0.1977
6 0.9443E-01-0.1253
7 0.2632 -0.4978E-01
8 0.3796 0.1178E-01
9 0.5138 0.4313E-01
10 0.5557 0.5208E-01
11 0.5048 0.8180E-01
12 0.4552 0.7566E-01

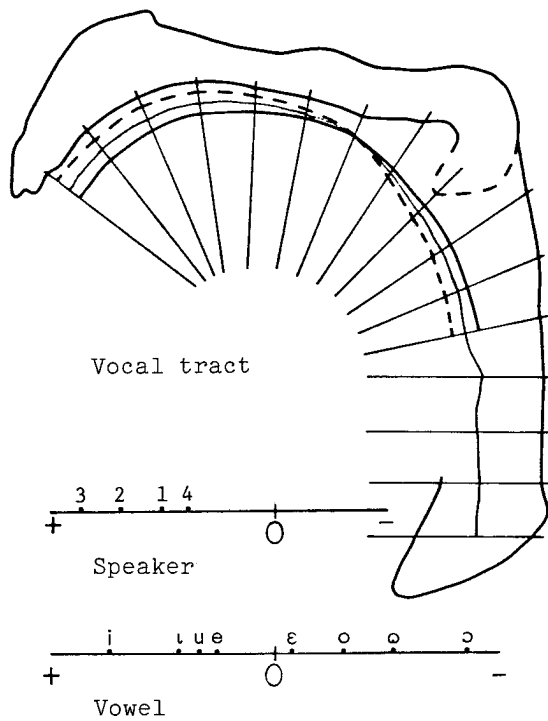

Figure A14. One-factor unique solution (4 speakers, 12 sections)

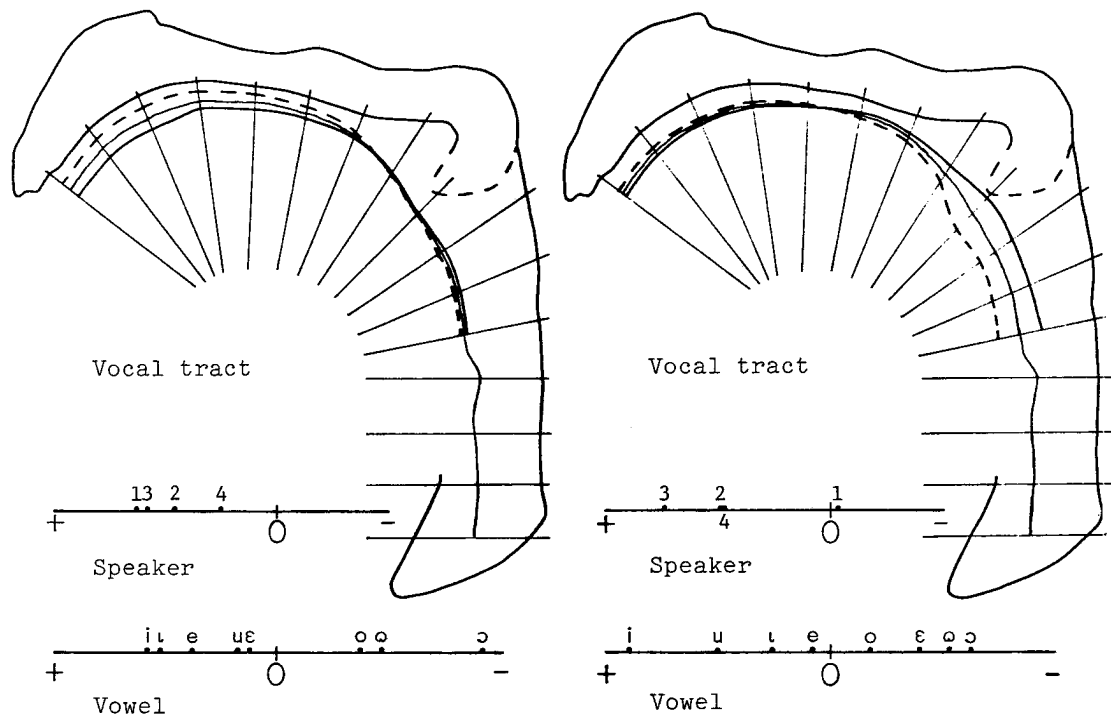

Figure A15. Two-factor unique solution (4 speakers, 12 sections)

Table A16. Three-factor unique solution (4 speakers, 12 sections).
Correlation squared= 0.9308652.

MODE A: SPEAKERS

1	1.192	-0.5176E-01	1.130
2	0.9285	-1.001	0.9430
3	1.221	-1.483	1.239
4	0.4756	-0.8921	0.5469

MODE B: VOWELS

1	[i]	0.6307	1.723	0.9427
2	[ɪ]	-0.3537	0.5475	0.3634E-01
3	[e]	0.2418	0.2158	0.4203
4	[ɛ]	-1.457	-0.8570	-1.151
5	[o]	0.3571	-0.3700	0.5833E-01
6	[ɔ]	-1.236	-1.263	-1.601
7	[u]	1.906	1.055	1.697
8	[ɔ̃]	-0.8862E-01	-1.052	-0.4019

MODE C: VOCAL TRACT SECTIONS

1	-0.2496	-0.3942	0.5281
2	-0.4166	-0.4360	0.5508
3	-0.5138	-0.4483	0.5144
4	-0.2576	-0.4396	0.1995
5	-0.2767	-0.2955	0.1011
6	0.1561E-01	-0.2844	-0.3278
7	0.5172	-0.2353	-0.9130
8	0.9070	-0.1680	-1.317
9	1.410	-0.1111	-1.797
10	1.629	-0.6511E-01	-1.954
11	1.554	0.1212E-01	-1.780
12	1.513	0.5782E-01	-1.628

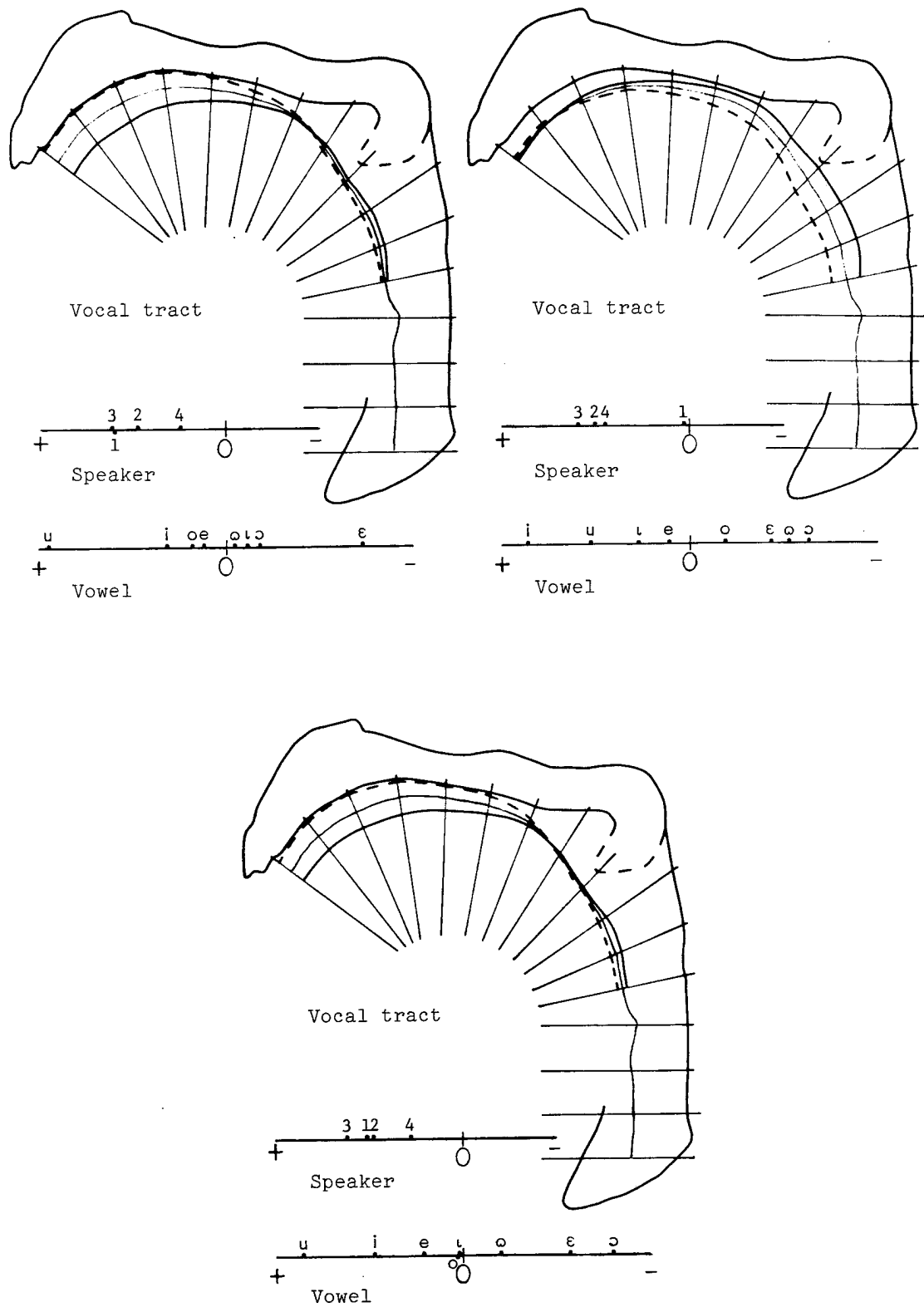

Figure A16. Three-factor unique solution (4 speakers, 12 sections)

Table A17. Four-factor unique solution (4 speakers, 12 sections).
Correlation squared= 0.9480866.

MODE A: SPEAKERS

1	-0.8072	-1.947	0.1936	0.4276
2	-0.9298	-0.7811E-01	1.055	0.9687
3	-1.344	0.1375	1.481	1.416
4	-0.8227	0.4287	0.8103	0.9345

MODE B: VOWELS

1	[i]	-0.2681	-0.6836	-1.516	-0.2753
2	[u]	-0.8101	-0.3012	-1.020	-0.6871
3	[e]	-0.4302E-01	-0.6781	0.2531E-02	0.1212
4	[e]	-1.674	1.551	-0.8448	-1.526
5	[o]	0.7366	0.1542	0.9438	0.6856
6	[ɔ]	-0.4140	1.353	-0.2233E-01	-0.8296
7	[u]	1.827	-1.632	1.087	1.886
8	[ɔ]	0.6459	0.2366	1.369	0.6252

MODE C: VOCAL TRACT SECTIONS

1	0.5719	0.1303	-0.8235	1.432
2	0.6096	0.5896E-01	-0.8051	1.352
3	0.5722	0.2316E-02	-0.7414	1.166
4	0.4882	-0.8060E-01	-0.5773	1.004
5	0.2033	-0.1105	-0.3316	0.3974
6	-0.2115	-0.2056	-0.1482	-0.2054
7	-0.7802	-0.2872	0.8435E-01	-0.9262
8	-1.126	-0.3209	0.2849	-1.379
9	-1.604	-0.3630	0.4485	-1.892
10	-1.783	-0.3474	0.5056	-2.056
11	-1.678	-0.2813	0.5141	-1.929
12	-1.669	-0.2095	0.4543	-1.842

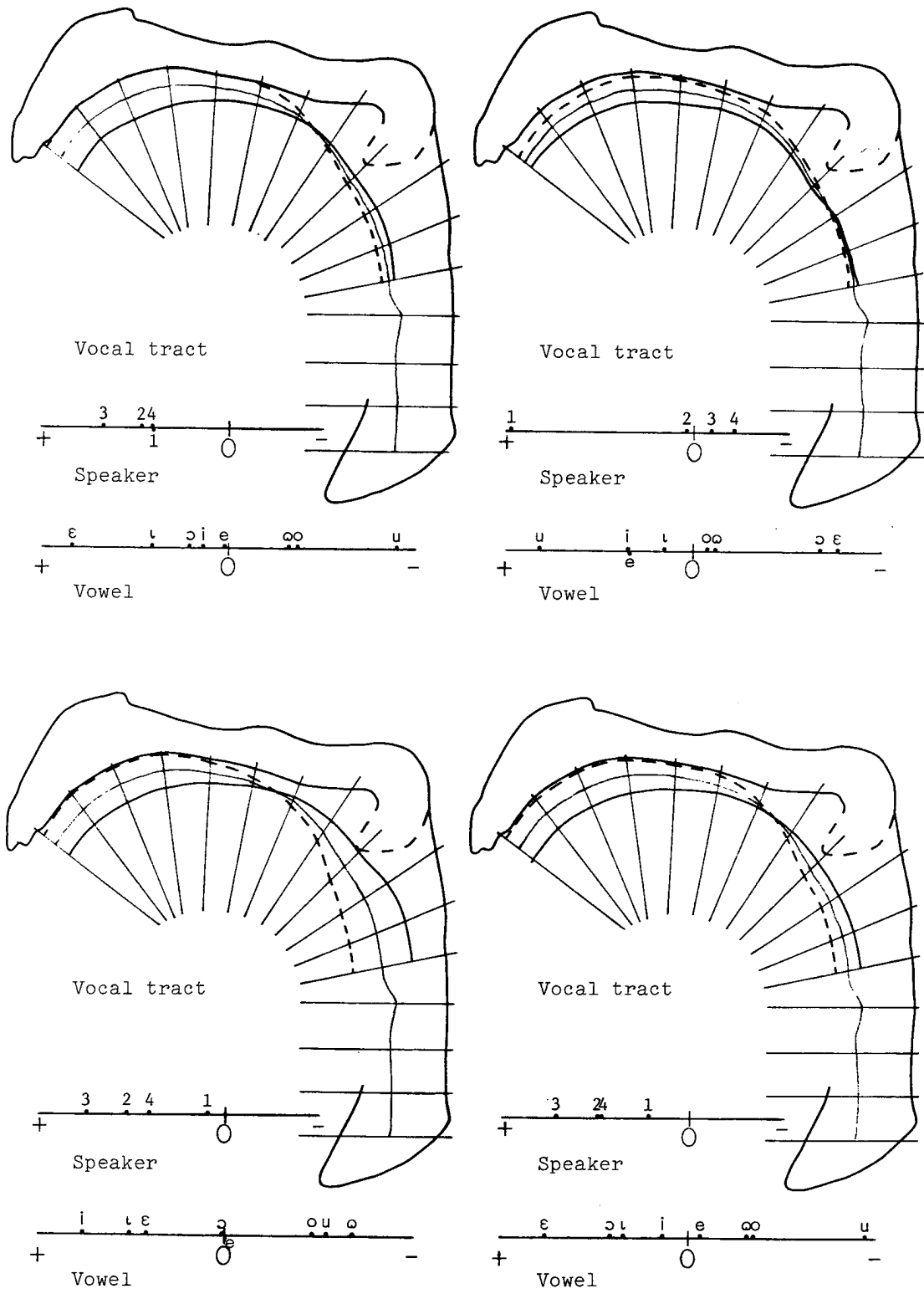

Figure A17. Four-factor unique solution (4 speakers, 12 sections)

Bibliography: References cited

- Blount, Ben, and Richard T. Curley. 1970. "The Southern Luo languages: a glottochronological reconstruction." *Journal of African Languages* 9:1-18.
- Crazzolara, J. P. 1933. *Outlines of a Nuer grammar*. Vienna: Verlag der internationalen Zeitschrift *Anthropos*.
- Disner, Sandra Ferrari. 1978. "Vowels in Germanic languages." *Working Papers in Phonetics* 40. University of California, Los Angeles.
- Greenberg, Joseph H. 1963a. *The languages of Africa*. Indiana University Research Center in Anthropology, Folklore, and Linguistics Publication, no. 25, and *International Journal of American Linguistics* 29.1, part II. Indiana University, Bloomington, Indiana.
- Greenberg, Joseph H. 1963b. "Vowel harmony in African languages." *Actes du second colloque international de linguistique négro-africaine*, pp. 33-37. Dakar: West African Languages Survey.
- Hall, Beatrice L., R. M. R. Hall, Martin D. Pam, Amy Meyers, Stephen A. Antell, and Godfrey K. Cheron. 1974. "African vowel harmony systems from the vantage point of Kalenjin." *Afrika und Übersee* 57: 241-67.
- Harshman, Richard. 1970. "Foundations of the PARAFAC procedure: Models and procedures for an 'explanatory' multi-modal factor analysis." *Working Papers in Phonetics* 16. University of California, Los Angeles.
- Harshman, Richard. 1976. "PARAFAC: Methods of three-way factor analysis and multi-dimensional scaling according to the principle of proportional profiles." Doctoral dissertation, University of California, Los Angeles.
- Harshman, Richard, Peter Ladefoged, and Louis Goldstein. 1977. "Factor analysis of tongue shapes." *Journal of the Acoustical Society of America* 62:693-707.
- Heinz, John M., and Kenneth N. Stevens. 1964. "Derivation of area functions and acoustic spectra from cineradiographic films of speech." Quarterly Progress Report, No. 74, pp. 192-98. Acoustics Laboratory, Massachusetts Institute of Technology.
- Heinz, John M., and Kenneth N. Stevens. 1965. "On the relations between lateral cineradiographs, area functions, and acoustic spectra in speech." Congress Reports, Ia, A44. Fifth International Congress on Acoustics (Liège).
- Huntingford, G. W. B. 1959. *Elementary lessons in Dho-Luo*. London: School of Oriental and African Studies.

- Jacobson, Leon C. 1977. "Phonetic aspects of DhoLuo vowels." In *Papers from the Eighth Conference on African Linguistics*, edited by Martin Mould and Thomas J. Hinnebusch, pp. 127-35. *Studies in African Linguistics*, suppl. 7.
- Jacobson, Leon C. Forthcoming. "Voice-quality harmony in Nilotic languages. To appear in *Issues in vowel harmony*, edited by Robert Vago.
- Ladefoged, Peter. 1964. *A phonetic study of West African languages*. West African Language Monographs, no. 1. Cambridge: Cambridge University Press.
- Ladefoged, Peter. 1971. *Preliminaries to linguistic phonetics*. Chicago and London: University of Chicago Press.
- Ladefoged, Peter. 1975. *A course in phonetics*. New York: Harcourt Brace Jovanovich.
- Ladefoged, Peter. 1976. "The phonetic specification of the languages of the world." *UCLA Working Papers in Phonetics* 31, pp. 3-21. University of California, Los Angeles.
- Lindau, Mona. 1975. "Features for vowels." *Working Papers in Phonetics* 30. University of California, Los Angeles.
- Lindau, Mona, Leon C. Jacobson, and Peter Ladefoged. 1972. "The feature Advanced Tongue Root." *Working Papers in Phonetics* 22, pp. 76-94. University of California, Los Angeles.
- Lindblom, B., and J. Sundberg. 1969. "A quantitative theory of cardinal vowels and the teaching of pronunciation." *Quarterly Progress and Status Report* 2/3:19-25. Speech Transmission Laboratory, Royal Institute of Technology (KTH), Stockholm.
- Nebel, P. A. 1948. *Dinka grammar*. Verona: Missioni Africane.
- Ogot, Bethwell A. 1967. *History of the Southern Luo. Volume 1. Migration and settlement, 1500-1900*. Nairobi: East African Publishing House.
- Painter, Colin. 1973. "Cineradiographic data on the feature 'covered' in Twi vowel harmony." *Phonetica* 28:97-120.
- Retord, Georges L. A. 1972. *L'agni, variété dialectale sarwi*. *Annales de l'université d'Abidjan, série H, V. fasc. 1*.
- Stafford, R. L. 1967. *An elementary Luo grammar*. Nairobi: Oxford University Press.
- Stevens, Kenneth N., and Arthur S. House. 1955. "Development of a quantitative description of vowel articulation." *Journal of the Acoustical Society of America* 27:484-93.
- Stewart, J. M. 1967. "Tongue root position in Akan vowel harmony." *Phonetica* 16:185-204.

Stewart, J. M. 1971. "Niger-Congo, Kwa." In *Linguistics in sub-Saharan Africa*, edited by Thomas A. Sebeok, pp. 179-212. Current Trends in Linguistics, volume 7. The Hague: Mouton.

Tucker, A. N. 1936. "The function of voice quality in the Nilotic languages." Proceedings of the Second International Congress of Phonetic Sciences (Cambridge).

Tucker, A. N. 1971. "Orthographic systems and conventions in sub-Saharan Africa." In *Linguistics in sub-Saharan Africa*, edited by Thomas A. Sebeok, pp. 618-53. Current Trends in Linguistics, volume 7. The Hague: Mouton.

Tucker, A. N. 1975. "Voice quality in African languages." In *Directions in Sudanese linguistics and folklore*, edited by Sayyid Ḥ. Ḥurreiz and Herman Bell, pp. 44-57. Khartoum: Khartoum University Press (for the Institute of African and Asian Studies).

Tucker, A. N. Forthcoming. *A grammar of Kenya Luo with vocabulary*.

Tucker, A. N., and M. A. Bryan. 1966. *Linguistic analyses: The non-Bantu languages of north-eastern Africa*. London: Oxford University Press (for the International African Institute).

Welmers, William E. 1973. *African language structures*. Berkeley and Los Angeles: University of California Press.