

Lawrence Berkeley National Laboratory

Recent Work

Title

AN ON-LINE SCINTILLATION COUNTER CONTROL SYSTEM

Permalink

<https://escholarship.org/uc/item/48p944gr>

Authors

Graven, R.M.
Andreae, S.W.
Brewer, J.H.
[et al.](#)

Publication Date

1971-03-01

For the Eurocon Computer Applications
Conference, Lausanne, Switzerland
October 18-22, 1971

RECEIVED
LAWRENCE
RADIATION LABORATORY

UCRL-20636
Preprint

CB

AND
DOCUMENTS SECTION

AN ON-LINE SCINTILLATION COUNTER
CONTROL SYSTEM

R. M. Graven, S. W. Andreae, J. H. Brewer,
R. J. Budnitz, A. C. Entis, F. A. Kirsten,
K. L. Lee, R. L. McCarthy, D. H. Miller, and W. N. Ross

March 9, 1971

AEC Contract No. W-7405-eng-48

TWO-WEEK LOAN COPY

*This is a Library Circulating Copy
which may be borrowed for two weeks.
For a personal retention copy, call
Tech. Info. Division, Ext. 5545*

LAWRENCE RADIATION LABORATORY
UNIVERSITY of CALIFORNIA BERKELEY

UCRL-20636

CB

DISCLAIMER

This document was prepared as an account of work sponsored by the United States Government. While this document is believed to contain correct information, neither the United States Government nor any agency thereof, nor the Regents of the University of California, nor any of their employees, makes any warranty, express or implied, or assumes any legal responsibility for the accuracy, completeness, or usefulness of any information, apparatus, product, or process disclosed, or represents that its use would not infringe privately owned rights. Reference herein to any specific commercial product, process, or service by its trade name, trademark, manufacturer, or otherwise, does not necessarily constitute or imply its endorsement, recommendation, or favoring by the United States Government or any agency thereof, or the Regents of the University of California. The views and opinions of authors expressed herein do not necessarily state or reflect those of the United States Government or any agency thereof or the Regents of the University of California.

AN ON-LINE SCINTILLATION COUNTER CONTROL SYSTEM*

R. M. Graven, S. W. Andreae, J. H. Brewer, R. J. Budnitz, A. C. Entis,
F. A. Kirsten, K. L. Lee, R. L. McCarthy, D. H. Miller†, and W. N. Ross

Lawrence Radiation Laboratory
University of California
Berkeley, California 94702

March 9, 1971

ABSTRACT

An on-line data collection system was built and used at the Lawrence Radiation Laboratory's Bevatron to measure the charge asymmetry in the decay $K_L^0 \rightarrow \pi^\pm \mu^\mp \nu$. The system records the states of 144 scintillation counters arranged into twelve hodoscopes, and it can test the operation of each counter. Information from pulse height analyzers, a digital voltmeter, time-to-amplitude converters, event clock, and scalers was recorded with each event. Using a PDP-9 computer, over 25 million events were recorded on magnetic tape during the tuning and data phases of the experiment. A CRT, programmed to display histograms and geometrical models of the experimental information as it was accumulated, was a valuable diagnostic tool allowing rapid visual assessment of both broad hodoscope and specific counter anomalies. The computer's power was greatly expanded by the addition of external control registers, hardware priority resolvers, event matrix logic, additional programmable flags, and input-output transfer request lines, in addition to software priority levels and the usual program interrupt line and peripherals. Inexpensive dual discriminators, nanosecond coincidence gates, testing circuits and new packaging methods were all used in developing this system.

* Work done under the auspices of the U. S. Atomic Energy Commission.

† Present address: Northwestern University, Evanston, Illinois 60202.

INTRODUCTION

An on-line data acquisition and analysis system that controls, checks, and records the states of 144 scintillation counters has been built and used to perform a charge asymmetry experiment. The experiment, performed at the Lawrence Radiation Laboratory's Bevatron, was a measurement of the relative decay rates of the K_L^0 meson into the states $\pi^\pm \mu^\mp \nu$. Figures 1 and 2 show the electronics and computer system. The equipment used to perform the experiment is described by a plan and elevation sketch in Fig. 3. Figure 4 is a photograph showing the magnet, absorber, and a few of the hodoscopes.

K_L^0 decays were detected by the usual coincidence and anti-coincidence techniques, using Chronetics logic modules to determine when a pion and a muon occur in coincidence (± 20 ns). This system allowed the trigger to be the result of either a simple coincidence or a complex ten-fold coincidence of various special counter(s) from selected hodoscope(s). Those counters comprising the trigger could either be selected manually or changed dynamically under program control. Events to be recorded were selected by a matrix of segments of hodoscopes. This allowed detailed on-line studies of the geometrical and range distributions of the particles being detected. The matrix selection criteria could be changed from a very lax to a quite stringent requirement, depending on the nature of the effect being studied. Results of a test (e.g., changing the magnetic field or adding counter(s) to the trigger) could be displayed in graphical form on a CRT.

A block diagram of the electronics and computer system is shown in Fig. 5. A modular construction technique was used to minimize down-time by simplifying repair, change and expansion. Fig. 6 is an example of the logic chain traversed by a typical photomultiplier tube pulse.

COMPUTER SYSTEM

Additional hardware was used to expand the number and length of I/O busses that were connected to the PDP-9. Priority resolver logic distinguished between four data channels. Each data channel used a core location to store word-counter and current-address information. In addition, each of four Automatic Priority Interrupt (API) levels could trap to any of eight core locations, providing 32 trap addresses. The priorities between flags connected to the same level were resolved in the module called "omnibus" (see Fig. 5). Voltage level converters between PDP-9 and IC levels were also provided.

The utility bin is similar to a NIM bin, except for special wiring to accept non-standard size-2 NIM modules. Each utility bin module provides the interface electronics for a different function, which simplifies not only functional expansion of the electronics, but also debugging of the combined hardware/software system. The modules used were: Flags and Input-Output Transfer (FIOT), External Control Registers (ECR), Automatic Priority Interrupt (API), NIdbus to NIne (NINI), and Accumulator Read-in Module (ARM). This left one spare module slot.

Four flags and 12 input-output transfer signals were used to synchronize the computer program to the pulsed beam of the Bevatron; to change the time sequences in the test generator; and to control the timing of event transfers from the logic to the computer. External control registers provided one bit for each counter, used to pass or block the output pulse after it had been discriminated and stretched (see Fig. 6). This individual gate on each counter could be changed manually or under computer control, allowing dynamic cross-talk checks. The automatic-priority-interrupt module allowed the experimenter to choose among four API levels or a program-interrupt line for each of the following: keyboard, printer, clock, and spare. The accumulator read-in

module provided a way to enter external information into the accumulator.

The NINI in Fig. 5 is the interface module which controlled the transfer of 18-bit words from the logic and its peripherals into core. A nuclear data bus-
sing system called NIDBUS sequentially selected the instruments to be read-out and transferred the information. It could operate manually (one word at a time); or slowly (typing out on an IBM Selectric typewriter); or rapidly (at micro-second speeds). Also, it could be operated independently of the computer, so that several system-debugging operations could be done simultaneously.

The matrix and control block decided which events were to be accepted for a preliminary analysis on the PDP-9. It also provided the timing and reset pulses for the logic.

LOGIC

Fig. 6 illustrates the logic chain traversed by a typical photomultiplier tube output pulse. First, small signals from noise and background particles were discriminated against. Secondly, the surviving (and therefore "interesting") pulses are stretched to a uniform $20 \text{ ns} \pm 1 \text{ ns}$. Thirdly, the state of a pre-set ECR bit determined if the information for this counter was to proceed. If so, two pulse output signals were available to feed logic arrays. Since the signals are NIM standard (zero to -0.7 volts), they could be used as inputs to Chronetics series 150 logic units. The fourth element is a 140 ns delay line.

Pulse output signals fed a Chronetics trigger-logic array, taking advantage of the versatility of these modules. One result of the trigger logic was a prompt-strobe signal whose width determined the resolving time of the next coincidence gate. Another result was a delayed-strobe signal which was timed to occur one Bevatron revolution (403 ns) after the prompt-strobe. This signal was used to measure the random counting rate of each counter. Two bits of memory stored this "signal" and "random" information for later transmission to the computer. An asynchronous or programmable test pulse could also be introduced to test the entire logic chain.

DISCRIMINATORS

Table I is a comparison between commercial Chronetics discriminators and the dual discriminators developed for this data collection system. The cost savings are a result of using MECL II* integrated circuits as well as eliminating the NIM-type mounting hardware, BNC connectors, switches and the versatility that NIM packaging provides. We used several bins of Chronetics Model 150's logic units in our trigger decision logic, and the 1968 model LRL discriminators in our data collection logic. The combination provides the following advantages: lower cost, programmable testing, compact packages, and smaller power supplies, without sacrificing versatility where it is needed.

* Motorola trademark

TABLE I
DUAL DISCRIMINATORS

Model	CHRONETICS		UC - LRL	
	101	151	1968	1970
Weight	900 grams	1,600 grams	58 grams	60 grams
Power	3.1 watts	14 watts	0.5 watts	1.5 watts
Volume	4900 cm ³	4300 cm ³	66 cm ³	66 cm ³
Minimum Threshold	100 mv	50 mv	50 mv	30 mv
Transit Time	7 ns	15 ns	18 ns	18 ns
Bandwidth	100 Mc	200 Mc updating	25 Mc	200 Mc updating
Outputs into 50 Ω	2 ea. - 300 Mv 1 ea. - 2.5 v	4 ea. - 700 Mv 1 ea. - 1 volt	2 ea. - 700 Mv 1 ea. complement	2 ea. - 700 Mv 1 ea. complement
Test Circuit	yes	no	yes programmable	yes programmable
Gated Output	yes	yes	yes	yes
Threshold Adjustment	knob discrete	knob continuous	screwdriver continuous	screwdriver continuous
Output Width Adjustment	knob 4.5ns → 1μs	knob and screwdriver 3ns → 5μs	capacitor and screwdriver 20ns → 5μs	capacitor and screwdriver 3ns → 5μs
APPROXIMATE COST	\$775	\$880	\$50	\$75

-9-

RESULTS

Both electrical noise from spark chambers in other nearby experiments and the Bevatron's oscillating magnetic field made small signal measurements difficult. Separate cables and line drivers from the omnibus to each peripheral helped to isolate problems and simplify repair. A background radiation level of about five neutrons/cm²/sec in the 1 - 3 MeV energy range did not seem to affect the equipment. The environment was also polluted by dust, vibrations, several earthquakes, and voltage surges when the high voltage power lines feeding the laboratory were sabotaged. Despite these obstacles, electronic problems rarely hindered the progress of the experiment.

ACKNOWLEDGEMENT

The authors would like to thank Mr. Oliver Jones and the Lawrence Radiation Laboratory's Physics Instrumentation Group for their assistance in this project.

FIGURE CAPTIONS

1. Data collection electronics
2. Expanded computer system and peripherals
3. Experimental equipment sketch
4. Magnet, absorber, and hodoscopes
5. Data collection, analysis, and recording system block diagram
6. Typical logic chain

REFERENCES

1. S. W. Andreae, editor, "Nine Notes", UCRL Internal Reports, Berkeley California, 1970.
2. F. A. Kirsten and D. A. Mack, "Systems of Fast Integrated Circuit Logic for Physics Instrumentation", UCRL-18166, also in International Symposium on Nuclear Electronics, Versailles, France, September 10 - 13, 1968.
3. F. A. Kirsten, "The Nidbus Data Bussing System", UCID-3133, Berkeley, California, December 1967 (unpublished).



CBB 702-1094

Fig. 1



CBB 702-1098

Fig. 2

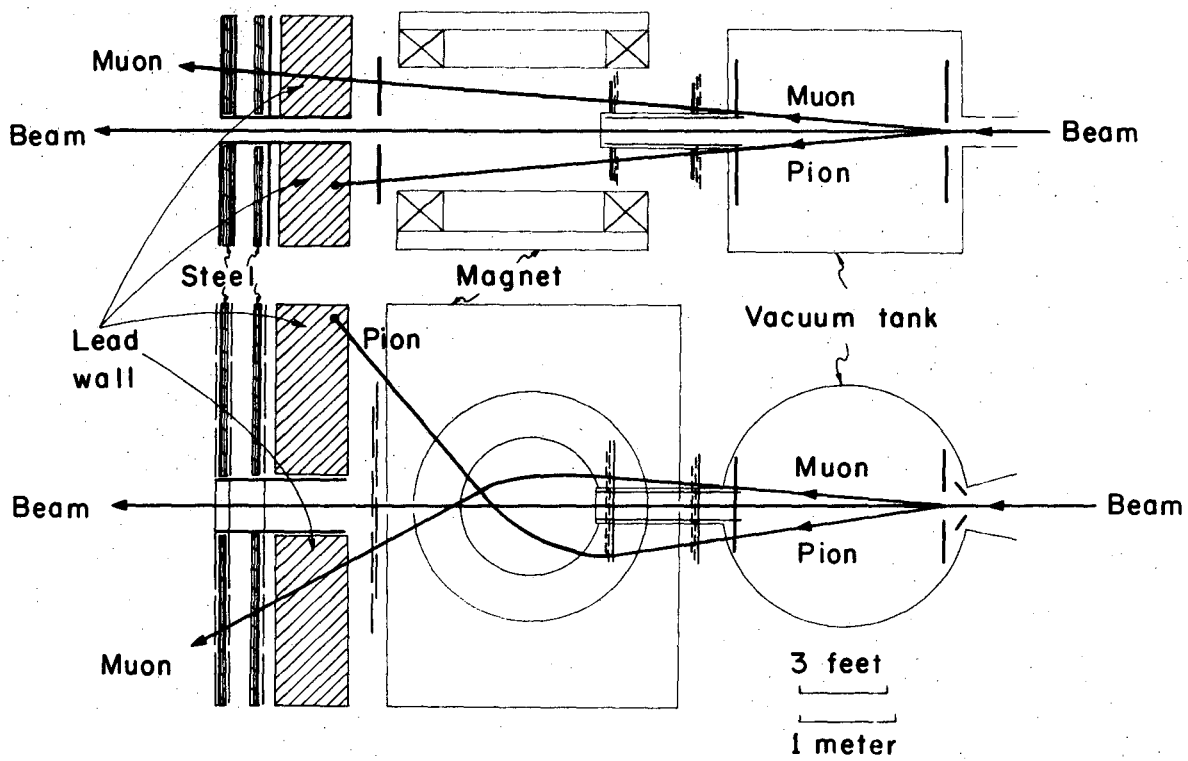

XBL7011-4161

Fig. 3

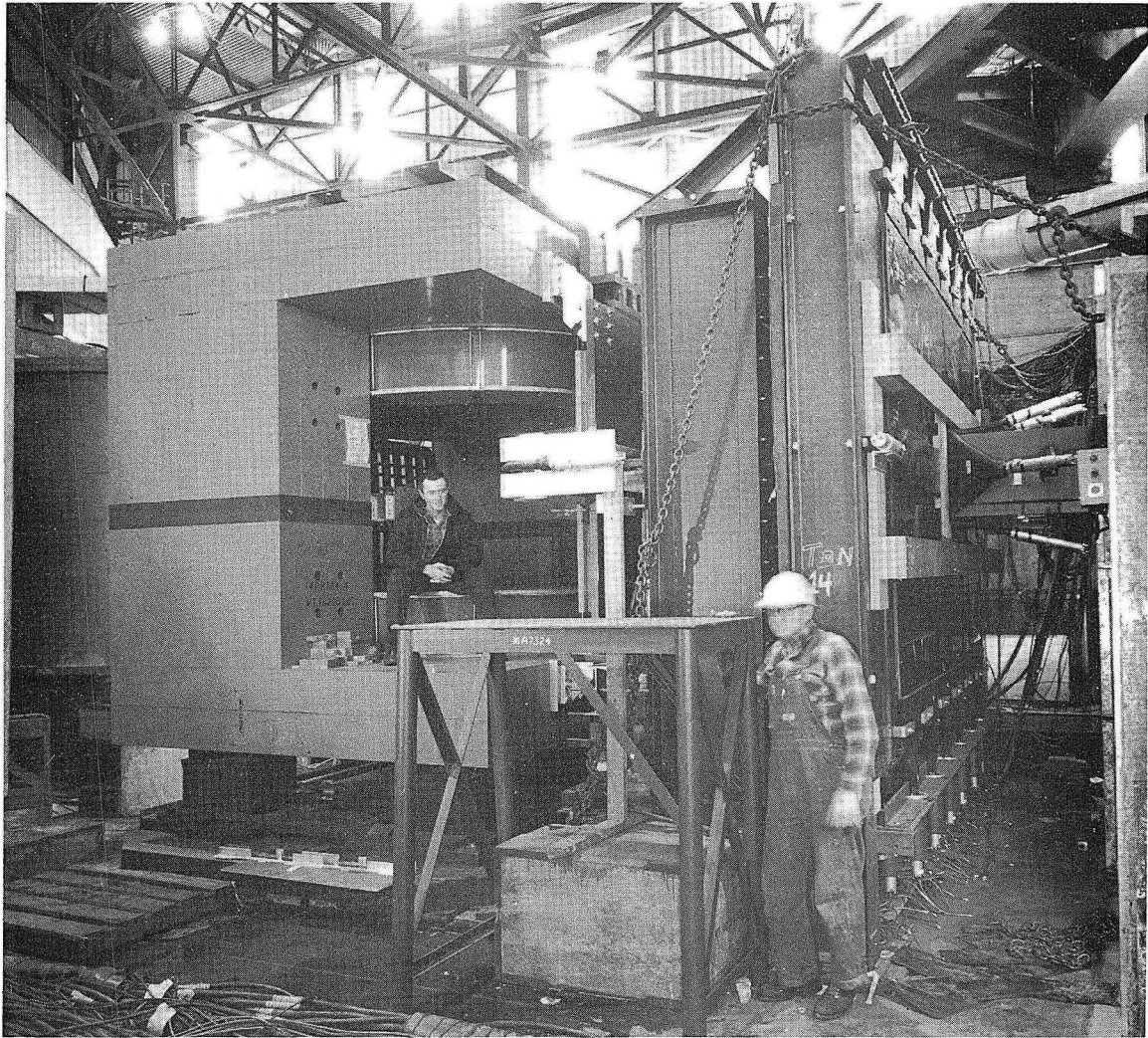

CBB 7012-5660

Fig. 4

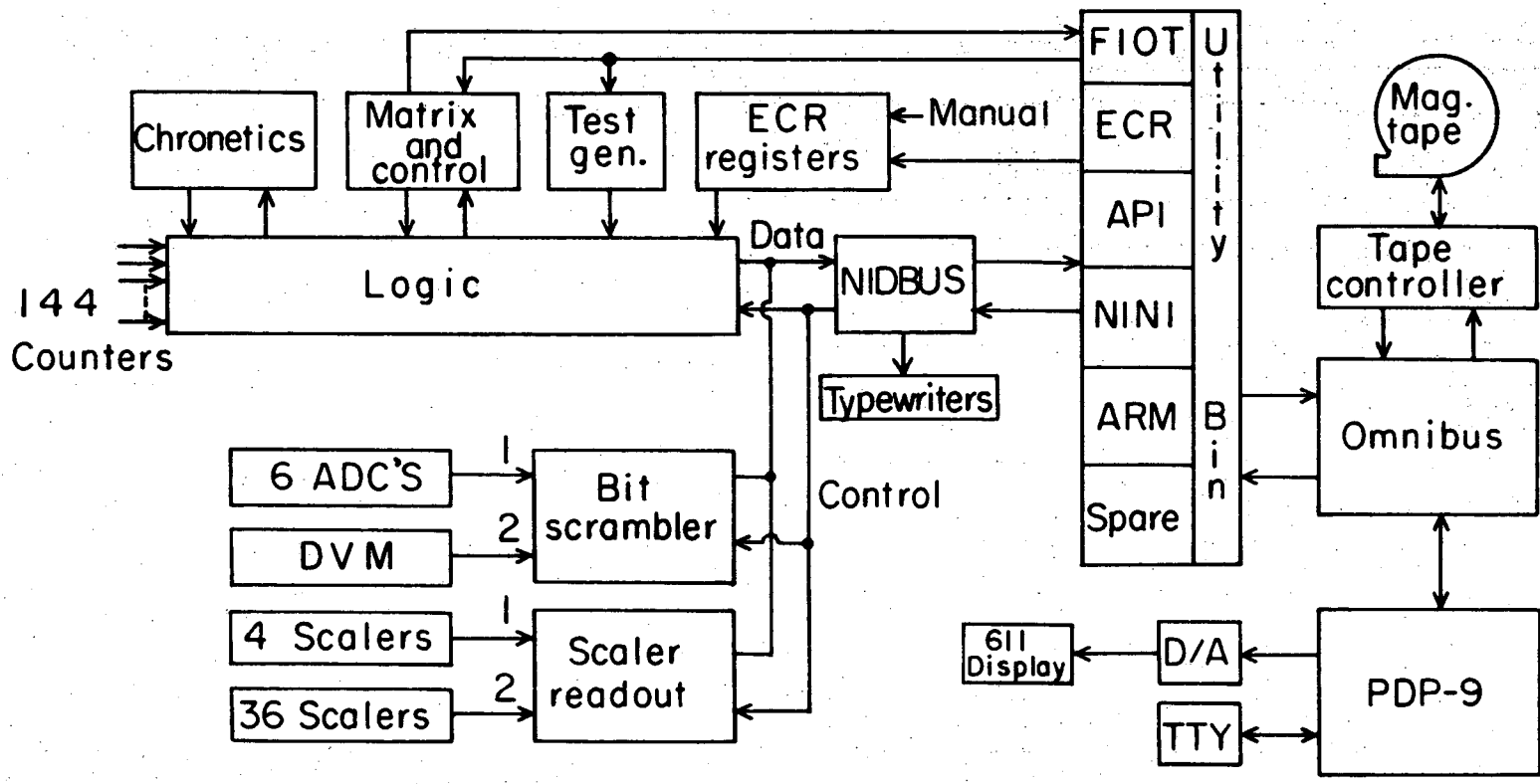

XBL712-2813

Fig. 5

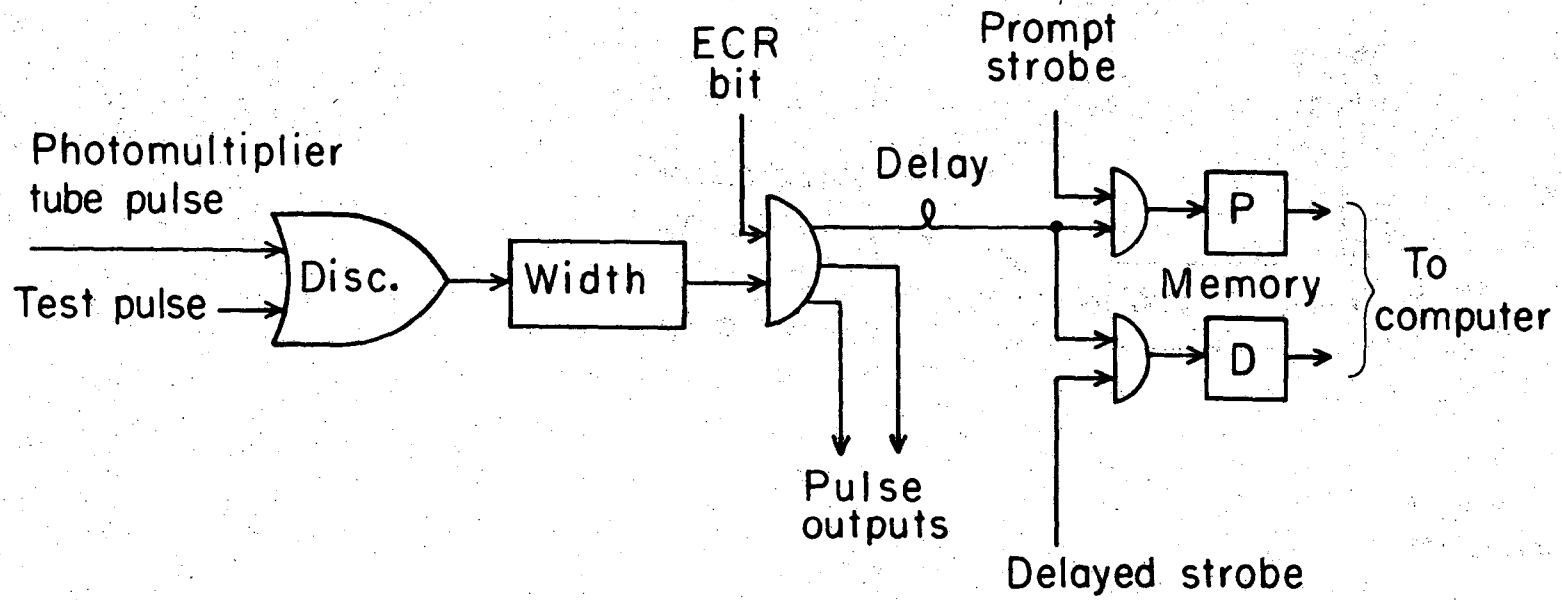

Fig. 6

XBL712-2814

LEGAL NOTICE

This report was prepared as an account of work sponsored by the United States Government. Neither the United States nor the United States Atomic Energy Commission, nor any of their employees, nor any of their contractors, subcontractors, or their employees, makes any warranty, express or implied, or assumes any legal liability or responsibility for the accuracy, completeness or usefulness of any information, apparatus, product or process disclosed, or represents that its use would not infringe privately owned rights.

TECHNICAL INFORMATION DIVISION
LAWRENCE RADIATION LABORATORY
UNIVERSITY OF CALIFORNIA
BERKELEY, CALIFORNIA 94720