

UC Santa Cruz

UC Santa Cruz Previously Published Works

Title

Structural Simplicity and Mechanistic Complexity in the Hammerhead Ribozyme

Permalink

<https://escholarship.org/uc/item/4906n97j>

Authors

O'Rourke, Sara M
Scott, William G

Publication Date

2018

DOI

10.1016/bs.pmbts.2018.07.006

Peer reviewed



Structural Simplicity and Mechanistic Complexity in the Hammerhead Ribozyme

Sara M. O'Rourke, William G. Scott¹

The Center for the Molecular Biology of RNA, University of California at Santa Cruz, Santa Cruz, CA, United States

¹Corresponding author: e-mail address: wgscott@ucsc.edu

Contents

1. Background and Structural Overview	178
2. Fast Minimal Hammerhead Ribozymes	181
3. Acid-Base Catalysis and the Hammerhead Ribozyme	182
4. Is the Hammerhead Ligation Reaction the Reverse of the Cleavage Reaction?	191
5. Do Cooperative Interactions in the Hammerhead Ribozyme Facilitate General Base Catalysis in the Cleavage Reaction?	194
6. Summary and Concluding Remarks	195
6.1 The Structure of the Hammerhead Ribozyme May Be Much Simpler Than We Have Thought	196
6.2 The Mechanism of the Hammerhead Ribozyme May Be Much More Complicated Than We Have Thought	196
6.3 Concluding Remarks	200
References	201

Abstract

Natural or full-length hammerhead ribozymes are up to 1000-fold more active than their minimal counterparts that lack a complex tertiary interaction that pre-organizes and stabilizes the ribozyme active site, positioning RNA functional groups to facilitate acid-base catalysis. The recent discovery that a single tertiary contact (an AU Hoogsteen pair) between Stems I and II confers essentially all of the enhanced activity greatly simplifies our understanding of the structural requirements for hammerhead ribozyme activity. In contrast, the simplest mechanistic interpretations are challenged with the presentation of more complex alternatives. These alternatives are elucidated and critically analyzed in the context of several of the active hammerhead ribozyme structures now available.



1. BACKGROUND AND STRUCTURAL OVERVIEW

The hammerhead RNA (or hammerhead ribozyme) is a small, self-cleaving RNA motif found within various viroid and satellite RNA genomes, as well as RNA transcripts and retrotransposons. The name “hammerhead” originates from the conserved secondary structure, which apparently resembles the head of a ball-peen hammer (or those of the similarly maligned sharks in the family *Sphymidae*). The hammerhead, being a comparatively simple catalytic RNA sequence, is quite possibly the most intensively studied ribozyme, both from the point of view of mechanistic biochemical characterizations and structural investigations. In Chapter 1 of *Progress in Molecular Biology and Translational Science (vol. 120): RNA*, the structures of the minimal and full-length hammerhead ribozyme sequences, together with a discussion of their mechanisms and role in mammalian gene regulation, were presented.¹ In this chapter, we focus upon more recent developments, along with their implications for better understanding the mechanisms of cleavage and ligation, as well as ribozyme design. In this section, we will briefly summarize the most relevant points presented previously.

The so-called minimal hammerhead sequence is that which enables self-cleavage. Minimal hammerheads consist of a conserved core of 15 mostly invariant nucleotides that are flanked by three helical stems, as depicted in Fig. 1, and are characterized with a catalytic turnover rate constant (k_{obs}) of about 1/min.² About 15 years subsequent to characterization of the minimal hammerhead sequence, two research groups discovered that natural hammerhead RNAs always included an additional set of sequence elements, with very little apparent conservation, that were responsible for mediating a tertiary contact.^{3,4} Several structures of hammerhead ribozymes with various tertiary contacts have now been elucidated.^{5–8} In addition to revealing the details of a complex interaction between Stems I and II (Fig. 1), these structures reveal the catalytically relevant conformation of the conserved core residues in the hammerhead ribozyme’s active site (Fig. 2). Presumably as a consequence of stabilizing the active-site conformation, full-length hammerhead ribozymes often possess a catalytic turnover rate constant (k_{obs}) greater than 100/min,⁹ indicating that the presence of a natural tertiary contact in the ribozyme greatly enhances catalysis. Remarkably, the tertiary contact region evaded characterization for 15 years, due to the absence of any clear sequence conservation pattern.

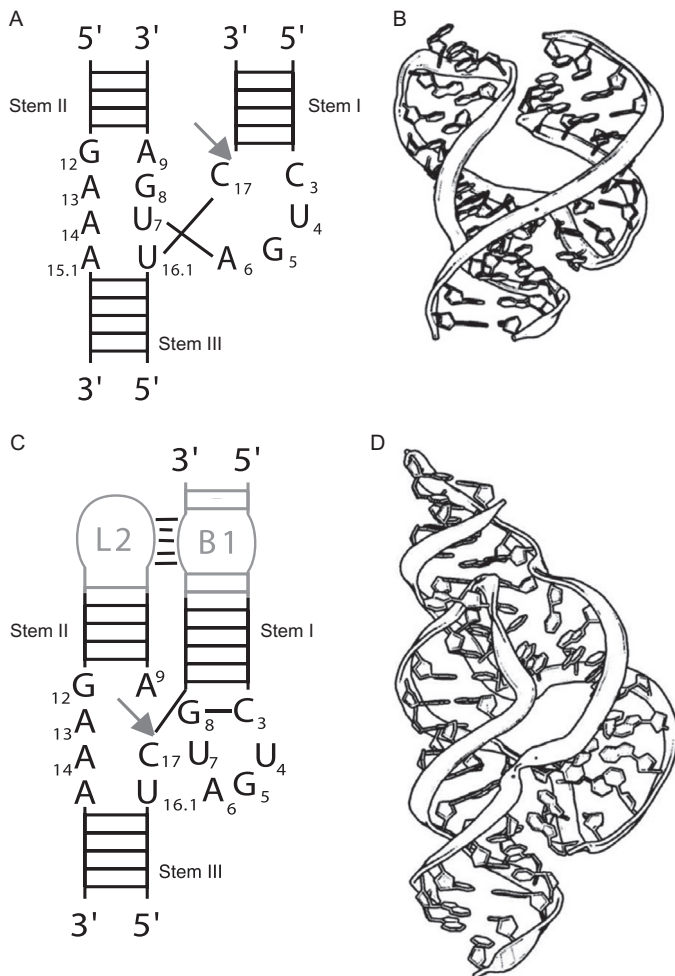

Fig. 1 The minimal and full-length hammerhead ribozymes. (A) A schematic representation of the secondary structure of the minimal hammerhead ribozyme. (B) The crystal structure of a corresponding minimal hammerhead ribozyme. The longer strand is the enzyme and the shorter strand is the substrate. (C) A schematic representation of the full-length hammerhead ribozyme emphasizing the presence of a tertiary contact between Stems I and II. (D) The crystal structure of a corresponding full-length hammerhead ribozyme. Again, the longer strand is the enzyme and the shorter strand is the substrate.

Both minimal and full-length hammerhead ribozyme sequences catalyze the same chemical reaction,¹⁰ i.e., nucleophilic attack by a deprotonated 2'-O of the cleavage site residue (conventionally denoted position 17, and typically a C, although in addition to C17, U17- and A17-containing

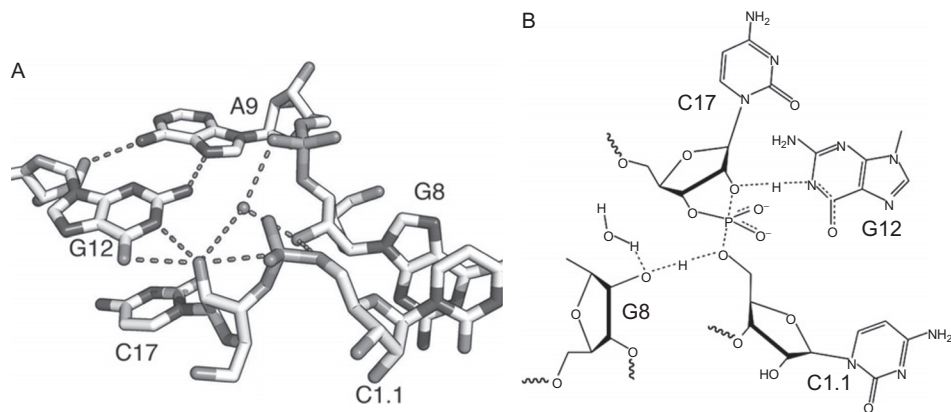

Fig. 2 The active site of the full-length hammerhead ribozyme and a mechanism for general acid-base catalysis. (A) Close-up of the crystal structure of the full-length hammerhead ribozyme showing G12 positioned for general base catalysis, the 2'-OH of G8 poised for acid catalysis, and the attacking nucleophile, the 2'-O of C17, positioned for an in-line attack upon the adjacent scissile phosphate. (B) A mechanistic diagram illustrating partial proton dissociation and transfer in a putative transition-state for general acid-base catalysis in the hammerhead ribozyme.

substrates are cleaved readily). G17 inhibits cleavage, presumably because it would have a strong propensity to pair with the invariant core residue C3, which is found in the full-length hammerhead structures to form a tertiary (but otherwise conventional) Watson-Crick pairing interaction with the invariant G8. (A potential G17-C3 pair would prevent the required G8-C3 pair from forming.) The hammerhead-catalyzed reaction is in essence the same as the first step of the two-step reaction catalyzed by RNase A, in which the deprotonated 2'-O of the cleavage site nucleophilically attacks the adjacent phosphorus, resulting in formation of cleavage products consisting of an RNA strand with a 2',3'-cyclic phosphate terminus and another (the leaving group in the S_N2 -like reaction) with a 5'-OH terminus. Based on the crystal structure⁵ and several sets of biochemical analyses,¹¹ the invariant core residue G12 is thought to play a role analogous to His12 in RNase A, that is, it is believed to be the general base in the cleavage reaction (when in a deprotonated form). Similarly, the general acid functionality analogous to His119 appears to be provided by the 2'-OH of G8. The active-site structure and a suggested transition-state are depicted in Fig. 2.



2. FAST MINIMAL HAMMERHEAD RIBOZYMES

Minimal hammerhead ribozyme sequences are frequently used to design sequence-specific RNA cleavage reagents, primarily due to the lack of sequence restrictions of potential RNA targets, and also because no knowledge of the complexities of the three-dimensional structure of the hammerhead ribozyme is required to design a hammerhead to target the sequence of choice.¹² For example, any RNA sequence that possesses a nucleotide triplet of RUX (where R is G or A, and X is C, U or A) can be targeted by a hammerhead designed to base-pair with the targeted substrate sequence simply by designing complementary sequences to form Stems I and III flanking the cleavage site. Unfortunately, the minimal hammerhead is rather slow, especially under typical *in vivo* conditions (where the concentration of free Mg^{2+} , for example, is far below the 10 mM standard *in vitro* conditions that yield even modest turnover rates on the order of 1/min), which has frustrated design of potential therapeutic agents based upon minimal hammerhead sequences.

The discovery and characterization of the full-length, or natural, hammerhead sequence that includes the tertiary contact region offer the promise of the potential to design far more active hammerheads that will function efficiently under *in vivo* conditions. But because of the complex base-pairing

and hydrogen bonding networks observed in the tertiary contacts of full-length hammerhead crystal structures, together with the apparent lack of any conserved sequence patterns (let alone the complexity of non-canonical base-pairing rules in tertiary interactions), designing full-length hammerheads to target arbitrary sequences of RNA has been considered far more difficult and daunting than the design of much less catalytically active minimal hammerhead sequences.

Recently, we discovered a very simple and highly effective work-around to the seemingly intractable problem of designing full-length hammerheads to cleave target RNAs.¹³ We found that the *only* additional sequence restriction that needs to be placed upon the substrate RNA is to have a pyrimidine (preferably a U) at position 1.7, i.e., 7 nucleotides downstream from the cleavage site. Hence, *any* RNA sequence of the form ...NNNNRUXNNNNNNYNN..., where N is any nucleotide, R is any purine, X is anything but G, and Y is any pyrimidine (preferably U), can be targeted with a fully active hammerhead sequence, provided that the 5'-end of the enzyme strand terminates at residue 2.6, and a GNRA tetraloop caps a Stem II sequence having exactly four base pairs. This permits the final A of the tetraloop to form a required Hoogsteen pair with U1.7 (Fig. 3). We experimentally determined that this Hoogsteen pair is both necessary and sufficient for conferring enhanced catalytic activity. All of the other tertiary contact pairing and hydrogen bonding interactions found in natural or full-length hammerhead sequences are not conserved, but are idiosyncratically required simply to prevent interactions forming that compete with this Hoogsteen pairing interaction. Design of synthetic hammerhead enzyme RNAs of a minimal sequence that terminates at residue 2.6 obviates the need for creating these additional contacts. As long as the pairing interaction can form between the A in the GNRA tetraloop and U1.7 in the substrate, such minimal hammerhead ribozyme sequences will possess the activity of full-length hammerheads, thus greatly simplifying the design of highly active RNA cleavage reagents.



3. ACID-BASE CATALYSIS AND THE HAMMERHEAD RIBOZYME

The first step of the RNase A cleavage reaction is the same as that catalyzed by the hammerhead ribozyme, i.e., nucleophilic attack of a 2'-O upon the adjacent phosphorus, resulting in formation of a 2',3'-cyclic phosphate upon phosphodiester backbone cleavage and liberation of a

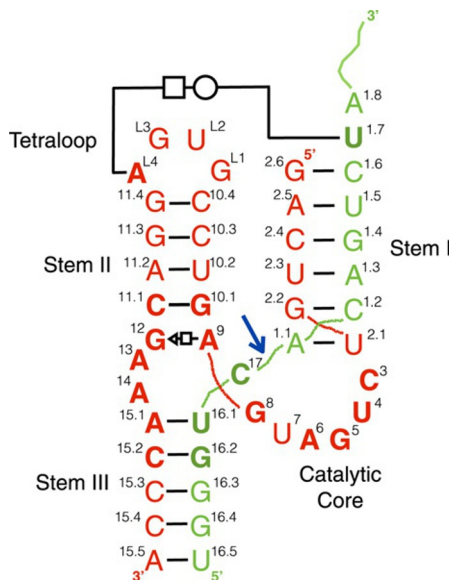

Fig. 3 A fast minimal hammerhead ribozyme, in which U1.7 of the substrate strand of Stem I can form a tertiary contact with the ultimate A of the GUGA tetraloop capping Stem II, via an AU Hoogsteen pairing interaction, indicated with a line marked with a circle and square. Conserved and invariant residues are indicated by bold-face. The phosphodiester cleavage site is indicated with an arrow. Stems I, II and III are labeled, as is the catalytic core region.

5'-OH RNA fragment downstream of the cleavage site. (The second step of the RNase A reaction, hydrolysis of the cyclic phosphate, does not have a hammerhead ribozyme counterpart.) As with RNase A, general acid-base catalysis is central to the enzyme mechanism. In the case of the RNase A cleavage reaction, the general base is His12 in the deprotonated form, and in the case of the hammerhead ribozyme, the general base appears to be G12 in the deprotonated form. The general acid in RNase A is a protonated His119, whereas the various full-length hammerhead ribozyme structures show the 2'-OH of G8 to be positioned for general acid catalysis in the cleavage reaction. It is therefore instructive to examine the pH-dependence of the RNA cleavage reactions catalyzed by RNase A and the hammerhead ribozyme to determine if these are consistent with the interpretation given.

For an enzyme that employs general acid-base catalysis in the rate-limiting step of the reaction, we can formulate the dependence of reaction rate upon pH using the Michaelis-Menten equation, recognizing that a general base in the active site of the enzyme will be inhibited by protonation,

whereas a general acid in the active site will be inhibited by deprotonation (or activated by protonation). The most intuitive starting point is to assume competitive inhibition, so that the effect of protonation will alter the apparent K_M (K_M^{app} in Eq. 1). The effect of an enzyme inhibitor upon K_M is to add in a term proportional to the inhibitor concentration ($[I]$ in Eq. 2) divided by the dissociation constant for the enzyme-inhibitor complex, and the effect of an activator is to add in a term proportional to the dissociation constant for the enzyme-activator complex divided by the concentration of the activator ($[I']$ in Eq. 2). In the case of general acid-base catalysis, both the activator and inhibitor are $[H^+]$, the inhibitor dissociation constant *must be* the acid dissociation constant for the general base, denoted K_a^{GB} , because the general base is *inhibited* by increasing proton concentration, and the activator dissociation constant *must be* the acid dissociation constant for the general acid, K_a^{GA} , because the general acid is *activated* by increasing proton concentration, as shown in Eq. (3), which can be put into the more convenient form of Eq. (4) using the definitions of pH and $\text{p}K_a$:

$$v_o = \frac{V_{\text{max}}[S]}{K_M^{\text{app}} + [S]} \quad (1)$$

$$K_M^{\text{app}} = K_M \left(1 + \frac{[I]}{K_I} + \frac{K_{I'}}{I'} \right) \quad (2)$$

$$K_M^{\text{app}} = K_M \left(1 + \frac{[H^+]}{K_a^{\text{GB}}} + \frac{K_a^{\text{GA}}}{[H^+]} \right) \quad (3)$$

$$K_M^{\text{app}} = K_M \left(1 + \frac{10^{-\text{pH}}}{10^{-\text{p}K_a^{\text{GB}}}} + \frac{10^{-\text{p}K_a^{\text{GA}}}}{10^{-\text{pH}}} \right) \quad (4)$$

Returning to RNase A, the first step of the RNA cleavage reaction, the general base corresponds to the deprotonated form of His12, and the general acid corresponds to the protonated form of His119, allowing us to write the expression for K_{app} more explicitly (Eq. 5). Although both the general base and general acid are histidines, their actual $\text{p}K_a$ values differ slightly due to differing microenvironments, with that of His12 being 5.8 and that of His119 being 6.2 (Eq. 6). The net effect of this in the context of the Michaelis-Menten equation for RNase A is a complex dependence of the initial rate upon pH (Eq. 7). Although we assumed competitive inhibition in this derivation, it is noteworthy that this assumption is not essential to the outcome. A similar dependence emerges for uncompetitive inhibition (Eq. 8), as well as for mixed inhibition:

$$K_M^{\text{app}} = K_M \left(1 + \frac{10^{-\text{pH}}}{10^{-\text{p}K_a^{\text{His12}}}} + \frac{10^{-\text{p}K_a^{\text{His119}}}}{10^{-\text{pH}}} \right) \quad (5)$$

$$K_M^{\text{app}} = K_M \left(1 + \frac{10^{-\text{pH}}}{10^{-5.8}} + \frac{10^{-6.2}}{10^{-\text{pH}}} \right) \quad (6)$$

$$v_o = \frac{V_{\text{max}} [S]}{K_M \left(1 + \frac{10^{-\text{pH}}}{10^{-5.8}} + \frac{10^{-6.2}}{10^{-\text{pH}}} \right) + [S]} \quad (7)$$

$$v_o = \frac{V_{\text{max}} [S]}{K_M + [S] \left(1 + \frac{10^{-\text{pH}}}{10^{-5.8}} + \frac{10^{-6.2}}{10^{-\text{pH}}} \right)} \quad (8)$$

To better focus upon the shape, rather than the magnitude, of the pH-dependence, we can set $[S] = K_M = V_{\text{max}} = 1$, and allow $[ES] = 1$. This enables us to plot pH vs. $\log k_{\text{obs}}$ in a manner essentially identical to that described previously by Bevilacqua.¹⁴ The derivation used here, however, has an intuitive advantage in that it allows us to identify the explicit contribution of the general base, due to the inhibitory effect of increasing proton concentration (decreasing pH), and therefore also the contribution of the general acid (which is activated upon protonation). Fig. 4 shows the familiar pH-dependence of the observed rate constant (k_{obs}) for RNase A, with the maximum rate at pH 6.0. The log-linear increase in rate with increasing pH corresponds to deprotonation of His12, the general base, and the log-linear decrease in rate with increasing pH corresponds to deprotonation of His119,

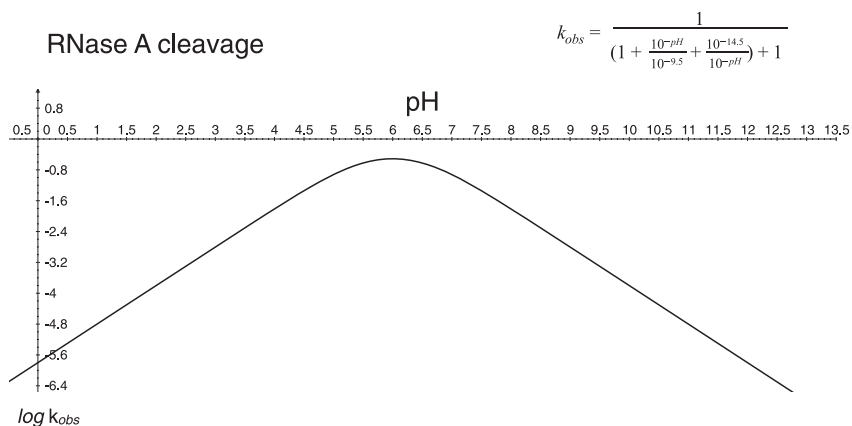

Fig. 4 A pH-dependent rate profile for RNase A.

the general acid. (The magnitude of the rate constant is arbitrary, and dependent upon parameters we have set to 1.0 for convenience, so this treatment, like that of Bevilacqua, focuses only upon relative rates.)

The hammerhead ribozyme also appears to employ general acid-base catalysis, wherein the deprotonated form of G12, hereafter referred to as $G12^-$, is thought to function in analogy with the deprotonated form of His12, based upon its position relative to the cleavage-site nucleotide in the various full-length hammerhead ribozyme structures. Unlike His, which has a physiologically important pK_a of 6.0, the relevant pK_a of guanosine is about 9.5. The predicted contribution to the relative rate is shown in Fig. 5, where the empirically observed pH-dependence is represented by black diamonds. Hence the hammerhead ribozyme rate profile is consistent with assignment of $G12^-$ as a general base. The apparent pK_a for the overall cleavage reaction reported in the literature varies between about 8.5 and 9.5 for the hammerhead ribozyme, depending upon the sequences used and reaction conditions, including the presence, identity and concentrations of divalent metal ions and other reaction additives, suggesting the possibility that the actual pK_a of G12 might be perturbed to a small extent, based upon metal binding to O^6 and N^7 of G12 (which has been observed in many crystal structures) and other microenvironment conditions.^{15–18} Furthermore, substitution of G12 with non-natural purine nucleotides having altered pK_a values shifts the profile curve to the left (while decreasing the relative rate), consistent with the assignment of G12 to the role of general base^{11,19} (Fig. 6).

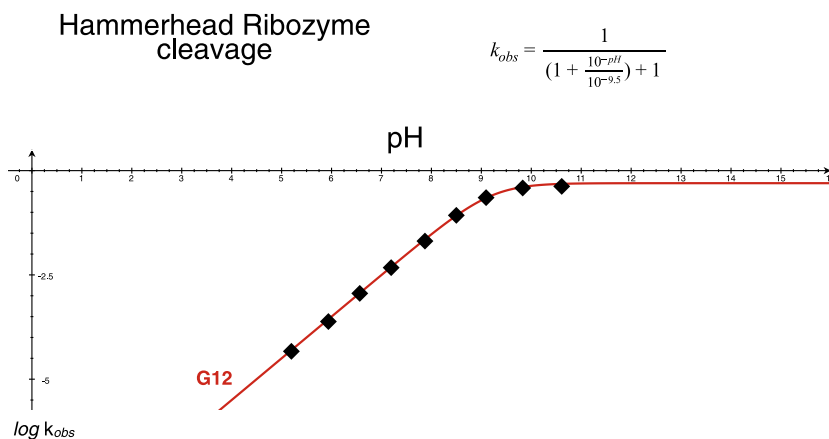

Fig. 5 A pH-dependent rate profile for G12-mediated general base-catalyzed hammerhead ribozyme cleavage, with representative empirically observed pH-dependent rate values represented as diamonds.

Based on crystal structures, the 2'-OH of G8 has been implicated as the general acid in the hammerhead cleavage reaction.⁵ The unperturbed pK_a of a 2'-OH is about 14–15, which corresponds to a pH well above the range within which ribozyme kinetics experiments can be performed. Fig. 7 shows the theoretical contribution of the 2'-OH of G8 to the reaction rate profile, but all we can say empirically is that the resultant flat-topped curve (Fig. 8) is not inconsistent with the observed rate profile (superimposed black

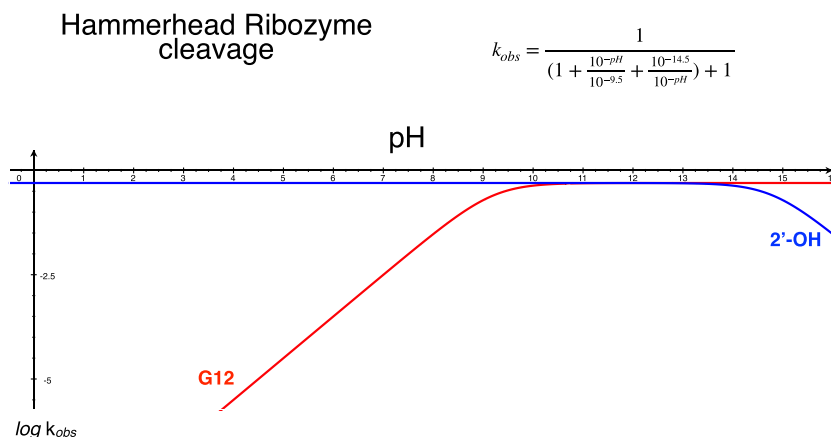

Fig. 6 A pH-dependent rate profile for G12 (general base) and 2'-OH (general acid) mediated hammerhead ribozyme cleavage.

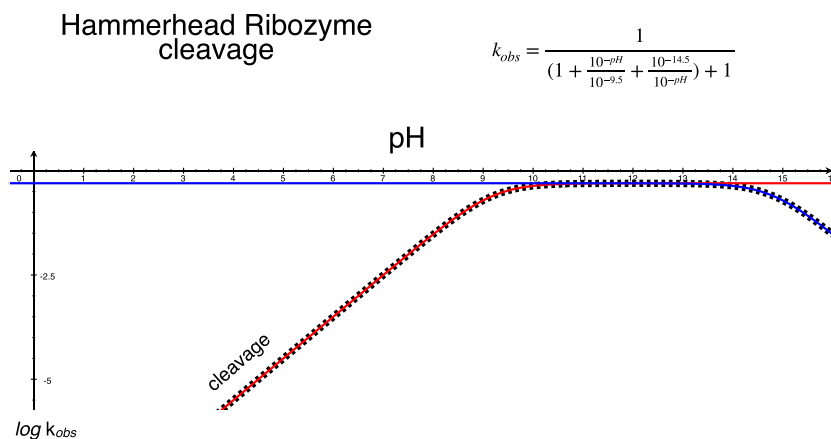

Fig. 7 A pH-dependent rate profile for G12 (general base) and 2'-OH (general acid) mediated hammerhead ribozyme cleavage, with the resultant theoretical pH-dependent rate plotted as a series of squares.

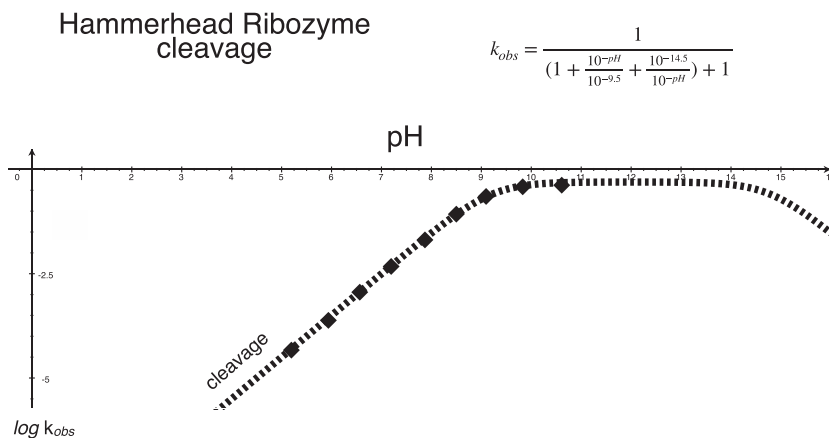

Fig. 8 The resultant from Fig. 7 (a series of squares) superimposed with the empirical observations from Fig. 5, showing that the general acid contribution to catalysis is not inconsistent with the observed rate dependence.

diamonds, as with Fig. 5). The plateau, which is experimentally observable for the hammerhead cleavage reaction under a variety of conditions,²⁰ results from the large gap between the pK_a for the general base (assumed to be 9.5 in these figures) and that of the general acid. Moreover, the plateau feature only emerges if the pK_a of the general base is much *lower* than that of the general acid. If the situation is reversed, wherein the pK_a of the general base is much *higher* than that of the general acid, not only is the relative rate of the reaction greatly diminished, but there is no plateau in the rate curve. Such a reversal would in fact occur for the hammerhead back reaction, because the roles of G12 and the 2'-OH of G8 would be reversed. The predicted pH-dependence of the ligation reaction, where G12 is now the general acid (with a pK_a of 9.5) and the 2'-OH of G8 is the general base, with a much higher pK_a of 14.5, is shown in Fig. 9. This prediction is also in accordance with the observation that the hammerhead ribozyme reaction, at least when measured with typical constructs and under typical reaction conditions, is one wherein cleavage dominates over the back reaction.²¹ At physiological pH values, cleavage is in fact predicted to greatly dominate over the back reaction. The consequences of this are discussed further in Section 4.

The RNase A analysis referenced above was originally developed to help elucidate the mechanism of the hairpin ribozyme.¹⁴ Like the hammerhead ribozyme, it catalyzes the same reaction as the first step of the RNase A cleavage reaction. The crystal structure, as well as other experiments, identifies $G8^-$ (in the deprotonated form) as the general base in the hairpin

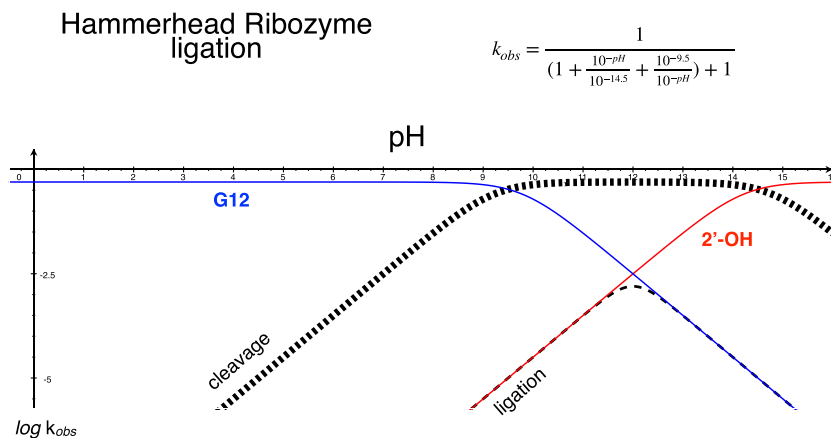

Fig. 9 Hammerhead ribozyme ligation, assuming that the mechanism is the reverse of the cleavage mechanism (i.e., that the 2'-OH is the general base, and G12 is the general acid). Ligation via the reverse-cleavage mechanism is thus predicted to be at least 1000-fold less efficient than cleavage at physiological pH.

ribozyme cleavage reaction, and A38⁺ (in the protonated form) as the general acid. Unlike the hammerhead ribozyme, the hairpin ribozyme reaction has been well characterized as pH-independent throughout a large range of physiologically relevant pH values (i.e., between ~5 and ~8.5). The analysis employed for the RNase A reaction was also employed to examine the hairpin ribozyme cleavage reaction, reproducing the empirically observed pH-independent plateau region by combining titration curves for G8 and A38 (which have unperturbed pK_a values of 9.5 and 3.5, respectively).

The previous analysis of the hairpin ribozyme cleavage reaction has been repeated in Fig. 10. Consistent with the claim that the plateau feature only emerges if the pK_a of the general base is much *lower* than that of the general acid, no resultant plateau emerges from combining the titration curves for the general base, G8 and the general acid, A38. Instead, a curve resembling that of RNase A, but centered approximately at pH 6.5, is produced, which appears at first glance to be inconsistent with the observed dependence of k_{obs} upon pH. However, if one instead considers the ligation reaction, A38 becomes the general base, and G8 becomes the general acid. Fig. 11 shows that the expected plateau then emerges. Moreover, the ligation rate is predicted to dominate over the cleavage rate. This is gratifying, because the hairpin ribozyme is in fact observed to favor ligation. The result appears to be counter-intuitive unless one considers that $k_{obs} \neq k_{cleavage}$, but instead, $k_{obs} = k_{cleavage} + k_{ligation}$,²² so that for a ribozyme in which ligase activity

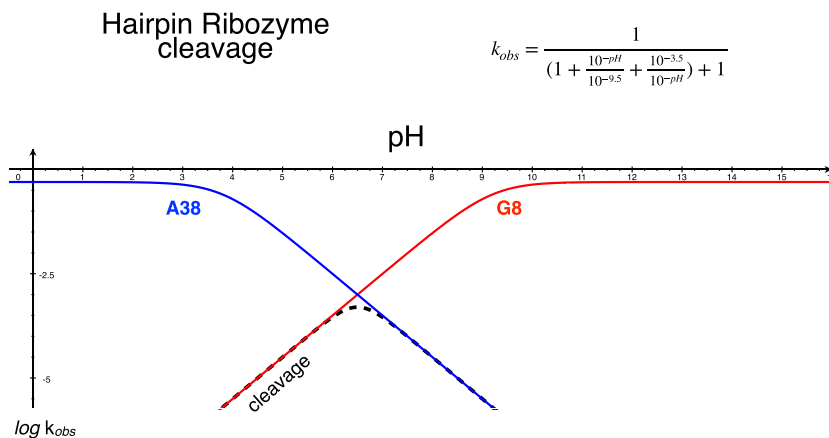

Fig. 10 The pH-dependence of the hairpin ribozyme cleavage reaction, with the hairpin ribozyme's G8 the general base, and A38 the general acid. Note the lack of a pH-independent plateau, in contrast with a previous analysis.

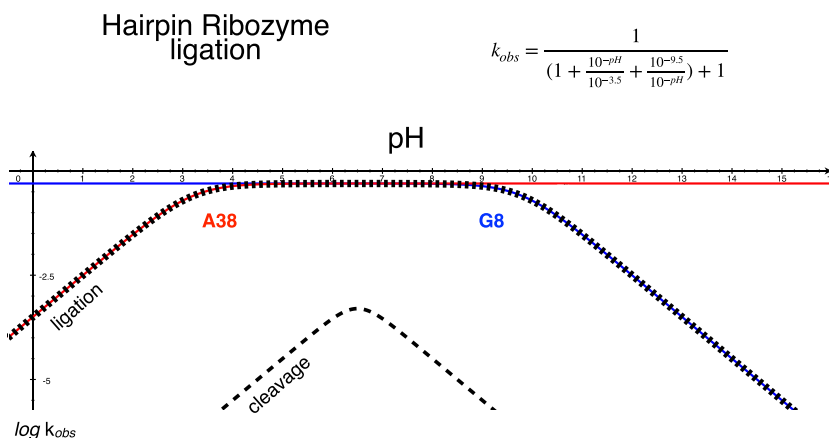

Fig. 11 The pH-dependence of the hairpin ribozyme ligation reaction, with the hairpin ribozyme's A38 the general base, and G8 the general acid. Note the pH-independent plateau is now a consequence of this analysis, and that the ligation reaction is favored over the cleavage reaction, in accordance with observation.

dominates, $k_{obs} \approx k_{ligation}$. In other words, standard single-turnover hairpin ribozyme kinetics analyses are not measuring the assumed cleavage reaction, but rather, they are (counter-intuitively) measuring the dominating ligation reaction. The approach to the derivation used here emphasizes the physical interpretation of the formalism, thus highlighting the consequences of the

predictions, as well as the origins of the contributions from the general acid and general base, and, therefore, the direction of the reaction.

The hairpin ribozyme is believed to employ a pK_a shift in A38 (from 3.5 to 5.5). It is interesting to note the effect of this perturbation upon the rates of the cleavage and ligation reactions near neutral pH. In the case of the faster ligation reaction, the pK_a shift has no effect above pH 6, whereas it significantly enhances the slower cleavage rate between pH 6 and 8, and moves the pH of the maximum cleavage rate from about 6.5 to 7.5. By contrast, for the hammerhead ribozyme, the putative pK_a shift suggested for G12 (the cleavage reaction general base) would have the effect of further enhancing the rate of the cleavage reaction at physiological pH values, but at the expense of further attenuating the ligation reaction (albeit only at higher pH values).



4. IS THE HAMMERHEAD LIGATION REACTION THE REVERSE OF THE CLEAVAGE REACTION?

The revised analysis for the hairpin ribozyme depicted in Fig. 12 clearly demonstrates how A38 and G8 can effectively collaborate to efficiently catalyze both the cleavage and ligation reactions required in the context of satellite virus RNA rolling circle replication, and how a suggested pK_a perturbation of A38 further enhances this potential by narrowing the difference between the ligation and cleavage rates. In contrast, the hammerhead cleavage reaction is very efficient, but the back reaction is drastically

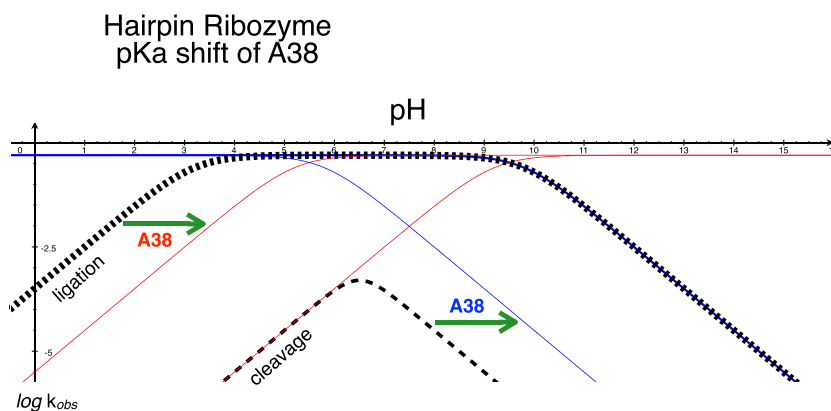

Fig. 12 The effects of a putative pK_a shift of A38 in the hairpin ribozyme cleavage and ligation reactions. Note that at physiological pH values, the shift only effects the cleavage reaction.

less so, especially at physiological pH (Fig. 9). Because ligation activity is also required for the reproductive cycle of satellite RNAs that have embedded hammerhead sequences, our analysis suggests that the hammerhead might be far less favored by natural selection than the hairpin ribozyme, an efficient ligase, whose nuclease activity is also appreciable. Nevertheless, hammerhead sequences are much more common than hairpin sequences,^{23,24} suggesting that there might be more to this story, i.e., that the simple, straightforward explanation that the ligation reaction is simply the reverse mechanism of the cleavage reaction clearly lacks explanatory power. In addition, Class I hammerheads, such as the one discovered in *Schistosoma mansoni* circular RNA elements, and the closely related Clec2-associated hammerheads found in the 3'-UTRs of mammalian mRNAs,²⁵ exhibit substantial ligase activity under favorable conditions,²⁶ seemingly at odds with the explanation that the ligation reaction is simply the reverse mechanism of the cleavage reaction.

Consistent with the prediction of two separate mechanisms for cleavage and ligation, respectively, is the case of *Avsunviroidae* viroids, in which the ligation reaction appears to be catalyzed by the chloroplastic isoform of tRNA ligase, a protein enzyme that uses 5'-OH and 2',3'-cyclic phosphate termini as a substrate.²⁷ It is unclear whether other hammerhead ligation reactions are also catalyzed by tRNA ligases. In addition, if the hammerhead ribozyme evolutionarily predated tRNA ligases (which are involved in the last step of spliceosome-independent intron excision in several tRNAs),²⁸ it would imply that hammerhead (or hammerhead-like) sequences would have had to possess the capacity to catalyze ligation in the absence of tRNA ligase.

One possibility is that the ligation reaction of the hammerhead ribozyme is mechanistically distinct from the cleavage reaction. In other words, since the 2'-OH of G8 has such a limited chemical potential as a general base, some other functionality within the hammerhead RNA (instead of external functionality provided by tRNA ligase) might instead participate in the ligation reaction, possibly requiring a conformational change in the hammerhead ribozyme structure in order to do so. The same studies that successfully identified G12 as a participant in general acid/base catalysis prior to the availability of the full-length hammerhead structure also implicated G8.¹¹ (Although the fact that the putative general acid in the cleavage reaction is the 2'-OH of G8, this may only be coincidental, as this previous study implicated the purine nucleotide base itself.) Comparing the minimal hammerhead structure to the full-length hammerhead structure is facilitated by

adiabatic morphing between the two sets of crystallographic coordinates, which also demonstrates that the minimal hammerhead conformation can be continuously deformed until it arrives at the observed conformation of the full-length hammerhead.²⁹ The most extreme change in the active site is the dramatic movement of G8, which in the minimal hammerhead structure is stacked under A9 but unpaired and that forms a tertiary Watson-Crick base-pairing interaction with C3 in the full-length hammerhead structure. The adiabatic morphing procedure interpolates an energetically plausible but hypothetical trajectory between the two crystallographic structural endpoints, generating 50 intermediates along the path of the conformational rearrangement. Intermediate #40 is one in which G8 is unstacked with respect to A9 but has not yet formed hydrogen bonds with C3. Instead, the Watson-Crick face of G8 points directly at the scissile phosphate. Superposition with the cleaved structure (2quw) suggests that the N1 of G8 in intermediate #40 may in fact be well positioned to facilitate general base catalysis in the ligation reaction, as shown in Fig. 13, implying that the observed plasticity of the hammerhead ribozyme, emulated in the adiabatic morphing procedure, could facilitate separate mechanisms for the cleavage and ligation reactions.

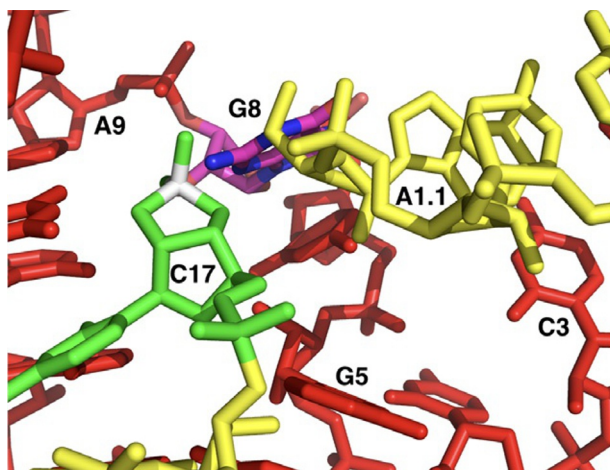

Fig. 13 Intermediate step #40 in the adiabatic morphing simulation of the conformational transition between minimal and full-length hammerhead ribozyme structures positions the N¹ of G8 proximal to the 5'-OH of what will be the attacking nucleophile in the ligation reaction of a previously cleaved hammerhead ribozyme, in which the 5'-OH-terminated and 2',3'-terminated ends of two RNA fragments will be ligated. Based upon this structural model, as well as biochemical experiments that implicate the nucleobase of G8 as mechanistically important, we propose that G8 becomes unpaired from C3 to serve as a general base in a mechanistically distinct ligation reaction.

Although it may be objected that this proposal appears to violate the principle of microscopic reversibility, it is worth remembering that this principle applies only to concerted, one-step reactions, whereas the hammerhead reaction, by necessity, will involve more than one step, as the initial protonation states of the enzyme must be restored subsequent to the cleavage reaction, and the division of the hammerhead RNA into distinct enzyme and substrate strands is an artificial experimental construct; the true biological reaction involves a single cleavage event followed by a single ligation event. In addition, a tRNA ligase-catalyzed reverse reaction is in a sense the most extreme example of a distinct mechanism for the reverse reaction. The proposal that at least some hammerhead ribozymes might possess a mechanistically distinct reverse reaction should be testable in that it predicts altered rate-pH profiles for purines substituted for G8 in constructs having a compensatory substitution at C3 that maintains Watson-Crick base-pairing (and thus the shape of the rate-pH profile for the cleavage reaction).



5. DO COOPERATIVE INTERACTIONS IN THE HAMMERHEAD RIBOZYME FACILITATE GENERAL BASE CATALYSIS IN THE CLEAVAGE REACTION?

Two recent publications argue that even the comparatively well-understood mechanism for how the general base facilitates catalysis in the cleavage reaction of the hammerhead ribozyme may in fact be far more complex than previously appreciated.^{30,31} It is proposed that the cleavage-site nucleotide, C17, becomes protonated, and therefore positively charged, at physiological pH, and that in the transition-state, cation- π interactions between G12⁻ (the deprotonated general base), C17H⁺ (the protonated cleavage-site nucleotide), and U16.1 (the invariant nucleotide 5' to C17), cooperatively stabilize the catalytically relevant form of the general base.

Chelation of a metal ion via O6 and N7 on the Hoogsteen face of G12 is thought to lower the apparent pK_a of G12, making it a more potent general base.^{32,33} This interaction, which has been frequently observed^{7,8,34-42} with both monovalent and divalent cations (e.g., Na⁺, Mg²⁺, Mn²⁺), may help to stabilize the deprotonated state (G12⁻) required for G12 to play the role of the general base in the cleavage reaction (in analogy to the requirement for a deprotonated His12 in RNase A). Stabilization of the deprotonated state (G12⁻) would thus manifest itself as an apparent

pK_a shift that is dependent upon the presence of a bound metal ion on the face of G12 and could help to explain the observation that metal ions enhance catalysis while not being strictly required for the catalytic mechanism.⁴³

Under physiological conditions in which very little (~ 1 mM) free Mg^{2+} is present, $C17H^+$, the protonated form of the cleavage-site nucleotide, is proposed to provide the positive charge in the absence of a metal ion chelated to G12. C17 in this context is proposed to experience a pronounced pK_a shift toward neutrality that enables it to facilitate catalysis by stabilizing the deprotonated state ($G12^-$) of the general base in a cooperative manner.³⁰ Experiments employing a kinetically well-characterized minimal hammerhead ribozyme reveal pH-dependent rate profiles that show not only the anticipated pK_a shift in the presence of increasing divalent metal ion concentrations, but also reveal “wavy” features in the rate profile curve at higher (e.g., ~ 50 mM) concentrations of Mg^{2+} due to data points that deviate from a simple G12 titration curve. These features are interpreted as evidence for a cooperative interaction that takes place between $G12^-$ and $C17H^+$, and the observed phenomenon is subsequently generalized to an elaborate, multi-channel three-dimensional kinetics scheme involving “dark pK_a shifts and wavy rate-pH profiles”³¹ to describe general acid-base catalysis.



6. SUMMARY AND CONCLUDING REMARKS

The mechanism describing hammerhead ribozyme activity should be able to account for (1) general base catalysis of the cleavage reaction, (2) general acid catalysis of the cleavage reaction, (3) general base catalysis of the ligation reaction, (4) general acid catalysis of the ligation reaction, (5) stabilization of the conformations of the enzyme and substrate in a pre-arranged active site, and (6) stabilization of the excess negative charge that accumulates in the pentacoordinated oxyphosphorane transition-state. The current state of our understanding can be summarized in these terms. (1) $G12^-$ is almost certainly the general base in the cleavage reaction, (2) the $2'-OH$ of G8 may be the general acid in the cleavage reaction, (3) the general base in the ligation reaction would therefore be the $2'-OH$ of G8, which is problematic, as noted above, (4) the general acid in the ligation reaction would therefore be G12, (5) the full-length hammerhead ribozyme crystal structures reveal the pre-organized active site of the hammerhead ribozyme and how it is stabilized by the tertiary contact between Stems I and II,

and the possible involvement of a metal ion in transition-state stabilization (6) is still a matter of active debate, with a suggestion (for example) that the A9 and scissile phosphates both coordinate a single metal ion in the transition-state. Only the first five aspects are examined here.

6.1 The Structure of the Hammerhead Ribozyme May Be Much Simpler Than We Have Thought

The essential structural principles of the hammerhead ribozyme may be far less complex than the various full-length hammerhead RNA crystal structures first suggested. In particular, the only required feature of the complicated network of hydrogen bonds and non-canonical tertiary base-pairing interactions between Stems I and II is the single AU Hoogsteen pairing between the A in the GNRA tetraloop of Stem II, and U1.7 in the substrate strand of Stem I. A minimal hammerhead RNA that permits this required interaction to form, by virtue of its design, possesses all of the catalytic enhancement of the full-length natural hammerhead sequences without additional complexities introduced by the unconserved interactions comprising the rest of the tertiary contact.

6.2 The Mechanism of the Hammerhead Ribozyme May Be Much More Complicated Than We Have Thought

The cleavage reaction catalyzed by the hammerhead ribozyme is rather simple. Abstraction of the 2'-proton from the 2'-OH of the cleavage-site nucleotide generates a nucleophile that attacks the adjacent phosphorus, breaking the 3'-5' phosphodiester linkage while forming a 2',3'-cyclic phosphodiester, and generating a 5'-OH-terminated RNA strand as the leaving group in an S_N2 reaction as the emerging 5'-O⁻ is protonated. In biochemistry, it does not get much simpler. The reaction is thought to be catalyzed by general acid-base catalysis, in a manner analogous to that of the first step of the RNase A reaction. G12⁻ is thought to be the general base (in analogy to deprotonated His12 in RNase A). A 2'-OH in the enzyme strand (belonging to G8) is positioned within hydrogen bonding distance of the leaving group 5'-O in the various crystal structures, leading to the suggestion that it may supply a proton (perhaps in a water-mediated proton relay), thus serving as a general acid. In that sense, the reaction should be no more complicated than that of RNase A, and in fact simpler, since the hammerhead only catalyzes the first step of the RNase A reaction (unlike RNase A, it does not hydrolyze the 2',3'-cyclic phosphodiester).

The principle of parsimony (attributed originally to William of Occam) is a heuristic edict suggesting that the simplest hypothesis explaining a phenomenon should be favored (and is generally the most potent argument against conspiracy theories). In science, it places the burden of proof upon the proponents of more complex explanations, and this burden should include providing evidence that a simpler explanation is insufficient, and that the more elaborate explanation or theory has greater explanatory power. Therefore, any proposal for a more complicated enzyme mechanism must begin with a compelling argument for why simpler alternatives lack explanatory power.

6.2.1 *The Ligation Reaction Mechanism Might Not Be the Reverse of the Cleavage Mechanism*

General base catalysis by $G12^-$, by itself, is sufficient to explain the observed pH-dependent rate profile of the hammerhead ribozyme cleavage reaction. Although the 2'-OH of G8 implicated as the general acid is not inconsistent with the observed pH-dependence, it is not strictly speaking required to explain the observed data. Specific-acid catalysis (i.e., protonation of the leaving group oxygen via a hydronium ion), for example, is equally consistent with the observations. All that can really be said with confidence is that the acid catalyst in the cleavage reaction has a very high pK_a .

The Principle of Microscopic Reversibility states that, for a concerted (or single-step) chemical reaction, the transition-state for the forward and reverse reactions is the same. This means that the mechanism for a concerted forward reaction should be the reverse of the back reaction. For this reason, the parsimonious expectation is that the hammerhead ligation reaction is simply the reverse of the cleavage reaction.

The replicative cycle of the satellite virus RNAs that contain hammerhead ribozymes requires both efficient cleavage activity and efficient ligation activity. However, as shown in [Section 3](#), ligation via the reverse of the cleavage mechanism will be extremely inefficient, and thus lacks the power to explain how the satellite virus RNA can replicate. This in turn compels us to propose that hammerhead RNA ligation may take place via a mechanism that is distinct from the cleavage mechanism. Indeed, a separate (protein) enzyme, tRNA ligase, catalyzes the reverse reaction in at least a subset of hammerhead-containing viroid RNAs.²⁷ Can a conformationally altered form of the hammerhead ribozyme itself do something analogous to this? Based on an intermediate structure interpolated via an adiabatic morphing of the minimal hammerhead RNA crystal structure conformation to that

of the full-length hammerhead crystal structure, as well as its implication in biochemical experiments, we suggest that the nucleobase of the invariant nucleotide G8 (in its N^1 -deprotonated form, $G8^-$) may be the base in the ligation reaction, and G12 (in its protonated form) continues to play its expected roll as the general acid in the ligation reaction (i.e., in exactly the same way as it would be expected to in the reverse-cleavage mechanism). We therefore propose an experimentally testable ligation mechanism that differs from the reverse of the cleavage mechanism only to the degree required by empirical observation. We note that although this proposal contradicts the parsimonious spirit of Microscopic Reversibility, it does not in fact contradict the actual letter of this Principle in that acid/base catalysis can never be a true concerted reaction. (Regeneration of the correct protonation states of the acid and base is a required second step, as can be seen from examination of the mechanism of RNase A, in which the hydrolysis of the 2',3'-cyclic phosphate in the second step has the effect of doing exactly this.)

6.2.2 General Base Catalysis in the Cleavage Reaction Mechanism Might Be More Complex

To explain the functional form of the pH-dependent rate profile observed at higher Mg^{2+} concentrations, it is proposed that the cleavage-site nucleotide, C17, becomes protonated, and therefore positively charged, at physiological pH, and that in the transition-state, cation- π interactions between $G12^-$ (the deprotonated general base), $C17H^+$ (the protonated cleavage-site nucleotide), and U16.1 (the invariant nucleotide 5' to C17) cooperatively stabilize the catalytically relevant form of the general base.³⁰

Although this is a quite intriguing mechanistic proposal that possesses the merit of recognizing that the hammerhead ribozyme structure does more than provide a passive scaffold that positions metal ions for RNA catalysis, the invoked "dark pK_a shifts" and "wavy rate-pH profiles"³¹ introduce a large degree of complexity. We need to ask whether this complexity is accompanied by a corresponding advance in explanatory power of how the hammerhead ribozyme works. In terms of the six aspects of the hammerhead reaction mechanism, this proposal most clearly addresses point 1 (general base catalysis in the cleavage reaction) in that it explains "wavy" rate profiles but may also be relevant to point 4 (general acid catalysis in the ligation reaction) in that a protonated $C17^+$ that favors $G12^-$ would also disfavor the protonated G12. This mechanistic proposal thus appears to have the unintended consequence of possibly gaining some more explanatory

power in terms of the cleavage reaction at the expense of losing even more explanatory power in terms of the ligation reaction.

It is also possible that the deviation from an ideally shaped general base titration curve observed in the minimal hammerhead is an artifact due to the use of a minimal hammerhead ribozyme for these experiments. High concentrations of metal ions may simply facilitate close approach of Stems I and II to partially mimic the effects of the tertiary contact that cannot form in this minimal construct. If the deviation is found to be statistically significant and reproducible in full-length hammerhead ribozymes that naturally form a tertiary contact, the need to invoke a complex cooperative interaction would be far more compelling.

Fig. 5 illustrates that general base catalysis (alone) by G12, with an unshifted pK_a of 9.5, has a high degree of explanatory power in that its titration curve reproduces the pH-dependence of the hammerhead ribozyme cleavage rate within the experimentally relevant window between pH 5 and 10.5. As noted in Section 3, the identity and presence of a metal ion bound to the Hoogsteen face of G12 can slightly alter the apparent pK_a of the reaction profile (i.e., it can influence the inflection point of the curve without altering its shape), and that substitution of G12 with purines having lower pK_a values is also consistent with this interpretation. It is also apparent from Fig. 5 that a small (≈ 1 pK_a unit) shift will have a comparatively minor relative cleavage rate enhancement, compared to the rather large rate enhancement of the hairpin ribozyme cleavage rate (Fig. 12) due to a proposed pK_a shift in A38. Invoking even a (noncooperative) pK_a shift in G12 offers little additional explanatory power. In addition, the experiments in which G12 is substituted with purines having lower pK_a values uniformly result in less active hammerhead ribozymes,¹¹ presumably because even though a greater fraction of the G12-substituted purine is in the deprotonated state at a given pH, it is a correspondingly less potent general base. Although a cation proximal to G12 may analogously change its effective pK_a , it does not entail that G12 will be a more potent general base.

The magnitude of the proposed pK_a shift in C17 is claimed to be significantly larger than the magnitude of the G12 pK_a shift thought to enhance hammerhead ribozyme catalysis.³⁰ Therefore, if protonation of C17 is required in the absence of a $G12^-$ stabilizing divalent cation, one has substituted the (relatively simple) requirement for understanding how a small pK_a shift takes place in G12 with the (more complex) requirement for understanding how a much larger pK_a shift takes place in C17. Since U17 can be substituted for C17, we now have the additional complexity

of explaining how a nucleotide base that never possesses a positive charge is tolerated in natural hammerhead sequences.

In contrast, the natural *Schistosomal* hammerhead RNA sequence gives rise to a tertiary contact structure in which two cytosines form a base-pair,³⁸ requiring an extra proton to be present at neutral pH (i.e., the crystal structure is consistent with a large pK_a shift of the tertiary contact cytosine). Despite the requirement for the presence of the tertiary contact for the observed (cooperative) 10^3 rate enhancement of this hammerhead sequence,^{9,42} there is no apparent signature in the rate-pH profile. Likewise, in RNase A, Lysine 41 (with a pK_a of approximately 10) does not influence the shape of the symmetric RNase A rate-pH profile, despite its close physical proximity to His12 and His119. These counter-examples should serve as positive controls when characterizing the empirical consequences of “dark” pK_a shifts, and evaluating the veracity of the claim.

6.3 Concluding Remarks

The hammerhead ribozyme, like all enzymes, catalyzes both a forward (cleavage) and reverse (ligation) reaction. Although the full-length hammerhead ribozyme is a much more efficient catalyst compared to the minimal hammerhead, at first glance this efficiency appears to come at the price of structural complexity. However, a more careful analysis reveals an underlying simplicity that had been masked by the presence of an elaborate tertiary structure, almost all of which is not strictly required for catalytic enhancement. This insight offers not only a great simplification in terms of understanding how the ribozyme works from a structural perspective, but also greatly simplifies the design of highly active hammerhead ribozymes as potential cleavage reagents that target RNA sequences of choice.

Conversely, the mechanism of the hammerhead ribozyme reaction may be far more complicated than originally assumed. The catalytic strategy employed by the hammerhead to accelerate the cleavage reaction appears to defy the need for efficient ligation. In a subset of natural hammerhead RNA sequences, a protein enzyme (tRNA ligase) appears to fill this need, but another subset of hammerheads are observed to catalyze their own ligation reaction efficiently, which raises the question of whether a different mechanistic strategy is employed for the ligation reaction. Based upon our previous structural analyses, we have suggested one such possible mechanism and have proposed how it might be tested experimentally.

REFERENCES

1. Scott WG, Horan LH, Martick M. The hammerhead ribozyme: structure, catalysis, and gene regulation. *Prog Mol Biol Transl Sci.* 2013;120:1–23.
2. Blount KF, Uhlenbeck OC. The structure–function dilemma of the hammerhead ribozyme. *Annu Rev Biophys Biomol Struct.* 2005;34:415–440.
3. De la Peña M, Gago S, Flores R. Peripheral regions of natural hammerhead ribozymes greatly increase their self-cleavage activity. *EMBO J.* 2003;22:5561–5570.
4. Khvorova A, Lescoute A, Westhof E, Jayasena SD. Sequence elements outside the hammerhead ribozyme catalytic core enable intracellular activity. *Nat Struct Biol.* 2003;10:708–712.
5. Martick M, Scott WG. Tertiary contacts distant from the active site prime a ribozyme for catalysis. *Cell.* 2006;126:309–320.
6. Chi Y-I, Martick M, Lares M, Kim R, Scott WG, Kim S-H. Capturing hammerhead ribozyme structures in action by modulating general base catalysis. *PLoS Biol.* 2008;6, e234.
7. Mir A, Golden BL. Two active site divalent ions in the crystal structure of the hammerhead ribozyme bound to a transition state analogue. *Biochemistry.* 2016;55:633–636.
8. Mir A, Chen J, Robinson K, et al. Two divalent metal ions and conformational changes play roles in the hammerhead ribozyme cleavage reaction. *Biochemistry.* 2015;54:6369–6381.
9. Canny MD, Jucker FM, Kellogg E, Khvorova A, Jayasena SD, Pardi A. Fast cleavage kinetics of a natural hammerhead ribozyme. *J Am Chem Soc.* 2004;126:10848–10849.
10. Nelson JA, Uhlenbeck OC. Minimal and extended hammerheads utilize a similar dynamic reaction mechanism for catalysis. *RNA.* 2008;14:43–54.
11. Han J, Burke JM. Model for general acid-base catalysis by the hammerhead ribozyme: pH-activity relationships of G8 and G12 variants at the putative active site. *Biochemistry.* 2005;44:7864–7870.
12. Eckstein F, Aurup H, Benseler F, et al. Design of hammerhead ribozymes for the inhibition of gene expression ex vivo by exogenous application. *Nucleic Acids Symp Ser.* 1993;29:115.
13. O'Rourke SM, Estell W, Scott WG. Minimal hammerhead ribozymes with uncompromised catalytic activity. *J Mol Biol.* 2015;427:2340–2347.
14. Bevilacqua PC. Mechanistic considerations for general acid-base catalysis by RNA: revisiting the mechanism of the hairpin ribozyme. *Biochemistry.* 2003;42:2259–2265.
15. Dahm SC, Derrick WB, Uhlenbeck OC. Evidence for the role of solvated metal hydroxide in the hammerhead cleavage mechanism. *Biochemistry.* 1993;32:13040–13045.
16. Nelson JA, Uhlenbeck OC. Minimal and extended hammerheads utilize a similar dynamic reaction mechanism for catalysis. *RNA.* 2008;14:43–54.
17. Nelson JA, Uhlenbeck OC. Hammerhead redux: does the new structure fit the old biochemical data? *RNA.* 2008;14:605–615.
18. Shepotinovskaya IV, Uhlenbeck OC. Catalytic diversity of extended hammerhead ribozymes. *Biochemistry.* 2008;47:7034–7042.
19. Schultz EP, Vasquez EE, Scott WG. Structural and catalytic effects of an invariant purine substitution in the hammerhead ribozyme: implications for the mechanism of acid-base catalysis. *Acta Crystallogr D Biol Crystallogr.* 2014;70:2256–2263.
20. Hertel KJ, Herschlag D, Uhlenbeck OC. A kinetic and thermodynamic framework for the hammerhead ribozyme reaction. *Biochemistry.* 1994;33:3374–3385.
21. Hertel KJ, Uhlenbeck OC. The internal equilibrium of the hammerhead ribozyme reaction. *Biochemistry.* 1995;34:1744–1749.
22. Stage-Zimmermann TK, Uhlenbeck OC. Hammerhead ribozyme kinetics. *RNA.* 1998;4:875–889.

23. de la Peña M, Cervera A. Circular RNAs with hammerhead ribozymes encoded in eukaryotic genomes: the enemy at home. *RNA Biol.* 2017;14:985–991.
24. de la Peña M, García-Robles I, Cervera A. The hammerhead ribozyme: a long history for a short RNA. *Molecules.* 2017;22:78.
25. Martick M, Horan LH, Noller HF, Scott WG. A discontinuous hammerhead ribozyme embedded in a mammalian messenger RNA. *Nature.* 2008;454:899–902.
26. Canny MD, Jucker FM, Pardi A. Efficient ligation of the *Schistosoma* hammerhead ribozyme. *Biochemistry.* 2007;46:3826–3834.
27. Nohales MÁ, Molina-Serrano D, Flores R, Daròs JA. Involvement of the chloroplast isoform of tRNA ligase in the replication of viroids belonging to the family Avsunviroidae. *J Virol.* 2012;86:8269–8276.
28. Abelson J, Trotta CR, Li H. tRNA splicing. *J Biol Chem.* 1998;273:12685–12688.
29. Scott WG. Morphing the minimal and full-length hammerhead ribozymes: implications for the cleavage mechanism. *Biol Chem.* 2007;388:727–735.
30. Frankel EA, Strulson CA, Keating CD, Bevilacqua PC. Cooperative interactions in the hammerhead ribozyme drive pK_a shifting of G12 and its stacked base C17. *Biochemistry.* 2017;56:2537–2548.
31. Frankel EA, Bevilacqua PC. Complexity in pH-dependent ribozyme kinetics: dark pK_a shifts and wavy rate-pH profiles. *Biochemistry.* 2018;57:483–488.
32. Roychowdhury-Saha M, Burke DH. Extraordinary rates of transition metal ion-mediated ribozyme catalysis. *RNA.* 2006;12:1846–1852.
33. Roychowdhury-Saha M, Burke DH. Distinct reaction pathway promoted by non-divalent-metal cations in a tertiary stabilized hammerhead ribozyme. *RNA.* 2007;13:841–848.
34. Lee T-S, Giambaşu GM, Sosa CP, Martick M, Scott WG, York DM. Threshold occupancy and specific cation binding modes in the hammerhead ribozyme active site are required for active conformation. *J Mol Biol.* 2009;388:195–206.
35. Martick M, Lee T-S, York DM, Scott WG. Solvent structure and hammerhead ribozyme catalysis. *Chem Biol.* 2008;15:332–342.
36. Lee T-S, Silva López C, Giambaşu GM, Martick M, Scott WG, York DM. Role of Mg²⁺ in hammerhead ribozyme catalysis from molecular simulation. *J Am Chem Soc.* 2008;130:3053–3064.
37. Lee TS, Silva-López C, Martick M, Scott WG, York DM. Insight into the role of Mg²⁺ in hammerhead ribozyme catalysis from X-ray crystallography and molecular dynamics simulation. *J Chem Theory Comput.* 2007;3:325–327.
38. Anderson M, Schultz EP, Martick M, Scott WG. Active-site monovalent cations revealed in a 1.55-Å-resolution hammerhead ribozyme structure. *J Mol Biol.* 2013;425:3790–3798.
39. Chen H, Giese TJ, Golden BL, York DM. Divalent metal ion activation of a guanine general base in the hammerhead ribozyme: insights from molecular simulations. *Biochemistry.* 2017;56:2985–2994.
40. Vogt M, Lahiri S, Hoogstraten CG, Britt RD, DeRose VJ. Coordination environment of a site-bound metal ion in the hammerhead ribozyme determined by 15N and 2H ESEEM spectroscopy. *J Am Chem Soc.* 2006;128:16764–16770.
41. Kim N-K, Murali A, DeRose VJ. Separate metal requirements for loop interactions and catalysis in the extended hammerhead ribozyme. *J Am Chem Soc.* 2005;127:14134–14135.
42. Osborne EM, Schaak JE, DeRose VJ. Characterization of a native hammerhead ribozyme derived from schistosomes. *RNA.* 2005;11:187–196.
43. Murray JB, Seyhan AA, Walter NG, Burke JM, Scott WG. The hammerhead, hairpin and VS ribozymes are catalytically proficient in monovalent cations alone. *Chem Biol.* 1998;5:587–595.