

Lawrence Berkeley National Laboratory

LBL Publications

Title

Photosynthesis

Permalink

<https://escholarship.org/uc/item/4cn200hn>

Authors

Calvin, M

Bassham, J A

Benson, A A

et al.

Publication Date

1952-03-01

DISCLAIMER

This document was prepared as an account of work sponsored by the United States Government. While this document is believed to contain correct information, neither the United States Government nor any agency thereof, nor the Regents of the University of California, nor any of their employees, makes any warranty, express or implied, or assumes any legal responsibility for the accuracy, completeness, or usefulness of any information, apparatus, product, or process disclosed, or represents that its use would not infringe privately owned rights. Reference herein to any specific commercial product, process, or service by its trade name, trademark, manufacturer, or otherwise, does not necessarily constitute or imply its endorsement, recommendation, or favoring by the United States Government or any agency thereof, or the Regents of the University of California. The views and opinions of authors expressed herein do not necessarily state or reflect those of the United States Government or any agency thereof or the Regents of the University of California.

UCRL-1720
Unclassified-Chemistry Distribution

UNCLASSIFIED

UNIVERSITY OF CALIFORNIA

Radiation Laboratory

Contract No. W-7405-eng-48

PHOTOSYNTHESIS

M. Calvin, J. A. Bassham, A. A. Benson and P. Massini

March, 1952

Berkeley, California

PHOTOSYNTHESIS¹M. Calvin, J. A. Bassham,² A. A. Benson and P. Massini³

Radiation Laboratory and Department of Chemistry

University of California

Berkeley, California

Although there has been considerable progress toward an understanding of the processes of photosynthesis in recent years, the advances have been followed rather closely by symposia, monographs and reviews of the subject matter, particularly during the last three years. (1,2,3,4,5,6,7,8)

In view of the comprehensive coverage it would appear that the present review might very well be limited to a discussion of certain subjects of special interest to the authors and some with which they are especially familiar. These are 1) the extensive discussion by Warburg and his co-workers of their proposal for the existence of a light induced oxygen absorption (and corresponding carbon dioxide evolution) which can amount to three or four times the net oxygen evolution by the same light; and 2) the discovery of the early participation of 7 and 5 carbon sugars in carbon dioxide reduction in photosynthesis together with some observations on the kinetics of the metabolic transformations.

1 - The work described in this paper was sponsored by the U. S. Atomic Energy Commission.

2 - Lt., USNR, Office of Naval Research Unit No. One, University of California, Berkeley. The opinions contained herein are the private ones of the writer and are not to be construed as official or reflecting the views of the Navy Department or the naval service at large.

3 - Fellowship of the Swiss Foundation: "Stiftung für Stipendien auf dem Gebiete der Chemie."

While it is true that a considerable number of significant publications have appeared in other aspects of photosynthesis (the Hill reaction and its coupling with carbon dioxide reduction (9,10,11,12,13,14,15,16,17,18,19); photochemistry of chlorophyll and related synthetic materials as model reactions in relatively simple defined physical systems (20,21,22,23); transfer of light energy within the pigment systems (24,25)) it is felt that they represent confirmation and extension of ideas which have already been discussed in a variety of earlier reviews and that a re-evaluation of them might very well be postponed until a later time.

THE ONE-QUANTUM PROCESS

In the course of studies on the maximum possible obtainable efficiency of photosynthesis, Warburg and his associates, using the gas exchange method that commonly bears his name, had occasion to shorten the alternating light and dark periods between which the net gain of oxygen or loss of carbon dioxide is determined down to periods as short as one minute of illumination alternating with one minute of darkness. Under these circumstances, the apparent efficiency of oxygen production during the one-minute illumination rose to a value which, when expressed in terms of the number of molecules of oxygen produced per quantum of light absorbed, approached one. (26,27,28) At the same time, the apparent gas absorption in the one-minute dark interval increased to values of the order of ten times that normally observed for dark respiration over long periods of time. This later enhanced oxygen absorption observed immediately following the illumination period is supposed to be going on during the illumination as well, thus leading to the suggestion that at all times under these optimum conditions, oxygen is actually being produced at a rate corresponding to one mole per quantum

absorbed, but that $2/3-3/4$ of this oxygen produced is re-absorbed in a light-enhanced back reaction leaving the net oxygen production observable for long periods corresponding to an efficiency of the order of $1/4$ molecule of oxygen per quantum absorbed. All the above observations, which refer to molecules of oxygen evolved in the light and absorbed in the dark, are supposed to be pertinent as well to molecules of carbon dioxide absorbed in the light and evolved in the dark.⁴

In later publications (34,35), Warburg was able to observe the gas exchanges immediately following the application of the measured light and immediately following the cessation of the measured illumination and to plot these changes as a function of time, making observations at one-minute intervals. A typical result is shown in Figure 1 (35). In this experiment, the unmeasured white light is applied to an extent which just balances the oxygen evolution and the carbon dioxide absorption by photosynthesis with the carbon dioxide evolution and oxygen absorption by

4 - Practically all of these observations were made by the "two-vessel method," a relatively new description of which is to be found in the papers by Warburg and Burk (29) and Burk, Schade, Hunter and Warburg (30). Since most of the observations were on Chlorella, whose physiological pH range is of the order of 4.5, the actual pressure changes observed when the experiments are performed in this pH range are due to the difference in solubility in the medium between oxygen and carbon dioxide. By using a pair of vessels whose geometry with respect to the algae and light are identical except for the gas volume above the algae suspensions, it becomes possible to determine, on the comparison of the observed pressure changes in the two different vessels, the ratio of oxygen over carbon dioxide whether it be in light or dark. Having determined this, the observed pressure change in a single vessel can then be converted into moles of oxygen evolved (absorbed) and moles of carbon dioxide absorbed (evolved). It should be pointed out here that there is a real difference of opinion as to the validity of the observations made by this method and these questions have been listed and discussed at some length (31,32,33).

respiration so that the manometers show no changes in pressures with time. Pressure changes are then brought about by the additional illumination with a measured beam of green light. Taking the data at face value, it is evident that what is represented in Figure 1 is a transient phenomenon with a logarithmic approach to a steady state. Warburg has chosen to interpret this result in terms of a primary photochemical reaction yielding molecular oxygen with a quantum requirement of one, accompanied by the proportional generation of a substance c (substances) which reacts with a fraction ϵ of the generated molecular oxygen, with a specific reaction velocity k . In qualitative terms, then, the falling off of the increase in pressure curve (Figure 1) is supposed to be due to the building up of the back reaction substance c . This he has expressed in algebraic terms in the following way:

Let

I_a = absorbed light intensity per minute, expressed as
 $\text{mm.}^3 \text{ Quanta/min. unit vol.}$

t = time of illumination by the measured light (min.)

x = evolved O_2 in time t by light I_a , in
 $\text{mm.}^3 \text{O}_2/\text{unit vol.}$

ϵ = the fraction of the O_2 evolved by the light reaction which
 reacts back.

c = concentration of the substance controlling the reverse reaction
 expressed in terms of back-reacting O_2 as
 $\text{mm.}^3 \text{O}_2/\text{unit vol.}$

k = sp. rate const. of the back reaction (min^{-1})

If the light intensities are so adjusted that the quantum requirement for O_2 in the light reaction, ϕ , is 1 then (since $I_a = + dO_2$ (light react.)/dt) then

$$+ dc/dt = \epsilon I_a - kc \quad (1)$$

integrated

$$\begin{aligned} dc/(\epsilon I_a - kc) &= dt \\ -1/k \ln(\epsilon I_a - kc) &= t + \text{const.} \end{aligned}$$

When $t = 0$ $c = 0$ $\text{Const.} = -1/k \ln \epsilon I_a$

$$\begin{aligned} \ln \left[\frac{\epsilon I_a}{\epsilon I_a - kc} \right] &= kt \\ \epsilon I_a &= e^{kt} (\epsilon I_a - kc) \\ \epsilon I_a e^{-kt} &= \epsilon I_a - kc \\ c &= \epsilon I_a (1 - e^{-kt})/k \end{aligned} \quad (2)$$

When $t \gg 1$, $c_{\text{Station}} = \epsilon I_a/k$

Further (if $\phi = 1$)

$$dx/dt = I_a - kc \quad (3)$$

Subst. (2) into (3) to eliminate c

$$dx/dt = I_a - \epsilon I_a (1 - e^{-kt}) \quad (4)$$

With the boundary conditions

$$\begin{aligned} t = 0, dx/dt &= I_a \\ t \gg 1, dx/dt &= I_a (1 - \epsilon) \end{aligned}$$

Eq. (4) gives on integration

$$x = I_a (1 - \epsilon)t + \epsilon I_a (1 - e^{-kt})/k \quad (5)$$

with the boundary conditions

$$t = 0, x = 0 \text{ giving } t \gg 1, x = I_a (1 - \epsilon)t + \epsilon I_a/k$$

If the quantum requirement is explicitly retained

$$x = I_a \phi (1 - \epsilon)t + \epsilon \phi I_a (1 - e^{-kt})/k \quad (6)$$

It is thus clear that the initial slope of the oxygen evolution curve should represent, according to this picture, the quantum requirement of the primary photochemical oxygen evolution while the initial slope of the absorption curve following the cessation of illumination should correspond to the quantum requirement of the continuous production of the back-reaction substance c . This latter, by the definition of c , should be equal to the former. There is some question as to the general validity of the observation itself (31,32,33) and this is especially true where very rapid observations are necessary. The question immediately arises as to how nearly the components of the gas phase are in equilibrium with the gaseous components of the solution and with the gaseous components within the green cells themselves. It is clear that if oxygen comes to equilibrium in these systems somewhat more rapidly than does carbon dioxide, a result such as that given in Figure 1 would ensue. Furthermore, this difference in rate might occur in the transfer between the gas phase and the liquid medium or between the liquid medium and the green cell interior where presumably the gasses are ultimately generated or absorbed.

However, even accepting the existence of this transient approach to a steady state associated with a change in light intensity as significant for the chemistry of the green cell itself, the interpretation given by Warburg is not unique but only one of a number of possible views even on a quantitative basis. The striking similarity between the data presented and the transient appearing in the electrical circuits cannot be overlooked. In fact there has been reported repeatedly, evidence for oscillatory transients in both carbon dioxide and oxygen evolution as well as

fluorescence, the most recent of which is that of Van der Veen (36). One of the simplest of such circuits would be a parallel arrangement of a resistance and a capacitor-resistance. The change in light intensity would correspond to a change in impressed potential and the gas flow would correspond to the charge flow. In chemical terms, the resistance would correspond to the specific rate constants of a series of reactions, while the capacitance would correspond to the size of the reservoirs involved in the equilibrium, which was shifted and maintained by a change in the steady state. It might be worthwhile to actually outline one such case in as general terms as possible.

A likely system having some of the above elements is shown diagrammatically in Figure 2 where the equilibrium between M and $A + O_2$ would correspond to the terminal oxygen evolving reaction. Defining corresponding terms in similar units to those used in the preceding derivation let

- I_a be the amount of light (number of quanta) absorbed by the photochemical apparatus (represented by the box P.A.) where it is converted into some chemical form (reduced and oxidized species).
- α be the proportionality constant between the number of quanta absorbed and the number of molecules (Q) of some species which reacts with the species M to produce molecular oxygen with a rate constant of unity ($u = 1$).
- r be the constant rate of the reverse reaction in the final equilibrium with molecular oxygen (also with carbon dioxide).
- β be the proportionality constant between the number of quanta absorbed and the steady net rate of formation of M.

m be the concentration of M at time t .

x be the number of moles of oxygen produced in time t .

Then,

$$dx/dt = (\alpha I_a)m - r \quad (7)$$

and

$$dm/dt = -\alpha I_a m + \beta I_a + r \quad (8)$$

Substitute p for $\beta I_a + r$

and q for αI_a

to give

$$dx/dt = qm - r \quad (9)$$

$$dm/dt = p - qm \quad (10)$$

Integrate equation (10) with the limiting condition $m = m_0$, when $t = 0$,

to give

$$m = p/q + (m_0 - p/q) e^{-qt} \quad (11)$$

Substitute equation (11) into equation (9) and integrate with the limiting condition that $x = 0$ when $t = 0$, gives

$$x = (p - r)t + (qm_0 - p) (1 - e^{-qt})/q \quad (12)$$

or replacing p and q ,

$$x = \beta I_a t + [\alpha I_a m_0 - \beta I_a - r (1 - e^{-\alpha I_a t})] / \alpha I_a \quad (13)$$

Equation (12) [equation (13)] gives precisely the same relationship between the amount of oxygen evolved and time as does equation (5) [equation (6)], the difference being in the significance of the constants.

It is thus apparent that the existence of a light-induced reaction consisting in the absorption of molecular oxygen and the evolution of molecular carbon dioxide at a rate of approximately three times that of the net evolution of oxygen induced by the same light is not an inescapable

conclusion to be drawn from the data as presented by Warburg. In fact, there exist two pieces of independent experimental evidence which would seem actually to preclude such a possibility. The system of forward and reverse reactions as proposed by Warburg is represented in its simplest form in Figure 3.

Thus, for every four molecules of molecular oxygen which are produced by the photochemical reaction three are supposed to be reabsorbed by the photosynthetic system in a dark reaction. Similarly, for every four molecules of carbon dioxide which are absorbed in the photochemical reaction three are re-evolved in this same dark reaction. Since the photochemical reaction is supposed to have a quantum requirement of unity it is clear that the quantum requirement for the net production of molecules of oxygen will be approximately four. Such a system would lead to a very rapid exchange between the oxygen atoms of the gaseous molecular oxygen and that contained in combination with the living organism as water and in other combined forms. The same accelerated exchange would be expected between the carbon atoms of the gaseous carbon dioxide and those incorporated in the photosynthetic organisms. The number of molecules exchanged (oxygen or carbon dioxide) due to this type of reaction alone should be approximately three times the net number of oxygen molecules produced. It is possible to determine whether or not such photochemically accelerated exchanges take place and, in fact, both of these isotopic tests have been applied, although not on the same systems.

Thus, if the organism is placed in contact with gaseous molecular oxygen labeled with O^{18} and the rate of change of the specific isotopic content of the gas is determined in the dark and compared with that which

occurs upon illumination, it should be possible to detect an accelerated rate of disappearance of labeled oxygen from the gas phase, since any labeled oxygen atom which is recombined in the organism will be so diluted by the large amount of unlabeled oxygen in the organism as not to reappear in the gas phase. In effect, this means that the photochemically produced oxygen would have no label, whereas that which is being reabsorbed would, of course, have the label from the gaseous phase. Experiments of this sort have been done by Brown, Nier and Van Norman (37) on a variety of organisms including Chlorella. In no case was there any evidence of an increased rate of disappearance of O^{18} from the gas phase under the influence of light.

The corresponding experiment with labeled carbon dioxide using C^{14} -labeled CO_2 has been done by Weigl and Calvin (38) on barley leaves. Here, also, there is no evidence of accelerated dilution of the residual carbon dioxide with non-labeled carbon from the organism under the influence of light. In fact, the only effects reported in each case were inhibitory effects on both of the rates mentioned.

The conclusions which were drawn by the authors of each of these above-mentioned experiments were weakened by the suggestion that upon illumination the oxygen which is absorbed in the respiratory reaction never escapes from the cells after its photosynthetic production, and the carbon dioxide evolved in the respiratory, or "Back", reaction never escapes from the cells prior to its photosynthetic incorporation. This criticism is incompatible with the assumption that the curves in Figure 1 are significant. In order that these curves, which are manometric changes with time, should correspond to the rates of chemical processes within the photosynthetic organisms, it was necessary to assume a complete equilibration between the gas phase and the molecular oxygen and carbon dioxide within the cell wall.

It thus appears that the transient phenomena observed by Warburg are better accounted for in terms of shifts of equilibria or steady states rather than in terms of an increased back reaction from the gas phase.⁵ It is also clear that under some circumstances it should be possible to observe, for short periods of time, rates of oxygen evolution or carbon dioxide absorption which would correspond to the apparent quantum requirements, even less than one (apparent quantum yield greater than unity). This is in no way to be construed as a violation of the Einstein law of photochemical equivalence. Without doubt there is a primary photochemical act somewhere in the photosynthetic apparatus which involves the transformation of electromagnetic to chemical energy with a quantum requirement of one, i.e., for every quantum absorbed one photochemical equivalent of a reaction will be brought about with concomitant storage of chemical energy. There is, of course, no requirement that there be any unitary relationship between quanta and molecules of gas observed manometrically.

This implied relationship between the number of quanta which might be required in the overall energy balance for the production of oxygen and the absorption of carbon dioxide and the mechanism by which this is achieved has led very often in the past thirty years to attempts to find ways of storing electromagnetic energy in that form, since it was very early clear that the amount of energy required to achieve the overall reaction of photosynthesis corresponded to that contained in at least four

5 - This includes the possibility that they will be due to differences in the specific rates of passage of oxygen and carbon dioxide through the cell wall. It is, however, unlikely that differences in the rate of establishment of equilibria between the medium and the gas can be called upon to account for it, as independent experiments in the authors' laboratory confirm.

quanta. With the growth of our knowledge of the way in which biochemical systems manipulate and convert energy from one form into another, e.g., the conversion of chemical energy to mechanical energy in muscle, has come the realization that the accumulation of the necessary calories to perform the overall reaction of photosynthesis might be done better chemically. It would appear that this is the predominant conception at present as it has been expressed in a wide variety of ways by many authors in many places. It would be futile at this point to try to review the history of the development of this idea in all its ramifications (5). Among the first of such suggestions was that of Ruben (39) and also of Lipmann (40) that energy required to carry out the overall photosynthetic reaction might be transported, at least in part, through high energy phosphate. This has even been carried to the extreme with the suggestion that there might be a 1:1 correspondence between quanta absorbed and individual high energy phosphate bonds formed, e.g., the terminal phosphate bond of ATP. This idea has been criticized on the basis of its enormous inefficiency (approximately 40 kcal. quanta being used to produce a single 12 kcal. bond) and almost certainly rightly so. The other alternative, namely, the subdivision of a quanta into two or three parts, has been rejected on the basis of lack of precedent (41). This is, however, probably due to the explicit or implicit attempt to perform the subdivision while the energy is in electromagnetic form or in the form of electronic excitation. This difficulty disappears if the conversion to chemical energy takes place at the 40 kcal. level, or thereabouts, and its subdivision occurs thereafter.

In relatively recent years a number of proposals have appeared concerning some of the more or less specific methods by which energy might be converted and brought to bear upon the oxygen liberation reactions and

the carbon dioxide reduction reactions. With the confirmation (42,43,44) of the idea that the reduction of carbon dioxide was separable⁶ from the primary photochemical act and was in itself a completely dark reaction (44) and the discovery that the earliest isolable intermediate of carbon dioxide incorporation by photosynthesis was phosphoglyceric acid, it became possible to suggest specific patterns by which high energy phosphate might play a part. It was clear that the initial carboxylation reaction leading to phosphoglyceric acid required the presence of a phosphorylated intermediate of relatively high energy level. This was presumed to have been formed either directly or indirectly through some oxidation reaction (not necessarily involving oxygen directly).

It was therefore proposed (47) that part of the initially produced reduced carbon be passed through a reoxidation cycle and thus have some of the reduced energy originating from the light reaction converted into high energy phosphate. The passage of an electron from a high reducing potential to a lower one on its way to molecular oxygen produces high energy phosphate. Evidence that such reactions might play a part in photosynthesis has been recently added to the literature (48).

These, and many other such suggestions, are all part of the same general conception of the rearrangement of chemical energy in dark reactions in preparation for the two reactions which can be observed manometrically in photosynthesis, viz., the evolution of molecular oxygen and the absorption of molecular carbon dioxide. It is in the reiteration and

6 - During the past year there has been discovered what appears to be a chemical light production following illumination of green plants (45) and also of isolated chloroplasts (46). This has a lifetime of the same order of magnitude as the "stored reducing power" (43) and is quenched by carbon dioxide in much the same way. Therefore, it seems that at least part of the initial path of entry and conversion of the photon is reversible.

emphasis of these ideas that the importance of the recent Warburg publications seems to lie, irrespective of whether or not the one quantum process has been observed manometrically, or even whether it will ever be.

Such a relation between dark reactions involving the accumulation and redistribution of energy and the gas exchange observable as a result of photochemical processes would necessarily have to be considered in any determination of the overall efficiency of the green plants in the energy conversion process, particularly when this determination is made via a gas exchange measurement. The efficiency of the energy conversion on the basis of the amount of carbon dioxide incorporated must depend very sharply on the fate of the carbon dioxide, since the energy required to reduce carbon dioxide to the level of formic acid is considerably less than that required to reduce it to the level of formaldehyde and this, in turn, is less than that required to reduce it to the level of methanol. On the other hand, the energy required to produce a mole of oxygen from water is very nearly independent of the fate of the hydrogen atoms involved in the reaction and is approximately 115 kcal.⁷ Therefore, measurement of oxygen evolved provides the preferable manometric unit for the determination of the efficiency of energy conversion.

⁷ = For example

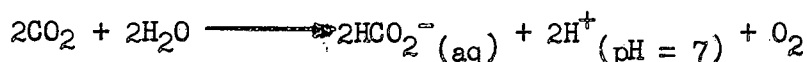

$$\Delta F = + 117 \text{ kcal}$$

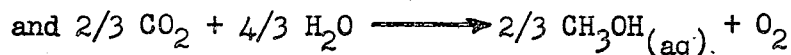

$$\Delta F = + 110 \text{ kcal}$$

However, the source of the energy required for this oxygen evolution might not be entirely the immediately absorbed and measured light. If some fraction of the energy transformed in the respiratory reactions were used in preparing intermediates for the oxygen evolution reaction, it is clear that this respiratory energy (measured by the amount of oxygen absorbed in the dark period) should not be subtracted from the observed oxygen evolution in a light period for the determination of an efficiency. If the measured light is of such intensity and under such conditions as to merely decrease the rate of oxygen absorbed the actual rate of energy transformation into a chemical form is still negative; that is, no energy is being stored but rather it is being expended. If we try to use the difference between the rate of oxygen absorption in the dark and the smaller rate of absorption in the light as the rate of energy storage due to the light itself, the result might very well be completely erroneous. Some unknown fraction of the energy being expended might actually be in the course of transformation and utilization for the preparation of compounds (intermediates) making it possible to evolve molecular oxygen from them by the addition of some energy directly from the measured light absorbed. Even if the light intensities and conditions are such as to lead to an actual evolution of oxygen it would still be an error to subtract from that evolution the apparent amount of oxygen absorbed in the dark either just before or just after the illumination period. This would be true irrespective of whether this so-called dark respiration is affected by light or not; that is, whether the dark respiration, as observed just prior to, or just succeeding an illumination period, proceeds at exactly the same rate or at some changed rate during the illumination period.

If it proceeds at the same rate then the energy so generated, or some fraction of it, may be used to prepare intermediates for oxygen evolution. If there is an intrinsic inhibition or acceleration of this process by light, then this same energy is being stored. Since the fraction of this "respiration generated" energy which may contribute to oxygen evolution is not known and may approach unity, it thus becomes impossible to determine accurately the efficiency of the energy conversion process from a gas exchange experiment alone when the net oxygen evolution is not very large compared to the dark respiration. The possible error from this source is, of course, that percentage of the total oxygen evolution which corresponds to the respiratory oxygen absorbed.

When the efficiency is determined by differential addition of light and measurement of the corresponding additional oxygen evolution, even if the initial state is one in which there is no net oxygen absorption (due to compensating light), this possible contribution of respiratory energy to the oxygen evolution reaction has not been considered or corrected for. The fraction of the energy from the compensating light which may be cooperating in the oxygen evolution almost certainly is dependent upon the differentially added light. The experimental result consequent upon this argument seems to have been observed by Kok (49) and others. In these observations the value of $\Delta \left[\frac{dO_2}{dt} \right] / \Delta I$ is dependent upon the value of I particularly at intensities around the compensation point.⁸

CARBON METABOLISM

In the course of studies designed to give more specific information about the sequence of compounds involved in the incorporation of carbon

8 - At very high light intensities the value (efficiency) falls off due to other limitations upon the rate of energy utilization.

dioxide into plant substances two new early products of this incorporation have been uncovered. These are certain phosphates of the seven- and five-carbon sugars, sedoheptulose and ribulose, respectively (50,51,52,52). An examination of the kinetics of their appearance together with a number of other compounds in what purported to be a steady state photosynthetic system has been made (54). Their appearance in the first few seconds of photosynthesis, the lack of any configurational relationship between them and the usual ultimate products, hexoses (glucose, fructose and sucrose), together with preliminary information suggesting that the labeled carbon atoms appear somewhere in the very rapidly turning cycle for the regeneration of the two-carbon carbon dioxide acceptor which ultimately leads to phosphoglyceric acid. This relationship is illustrated in Figure 4.

Ample precedent already exists for the fission of a ketopentose, such as ribulose, between carbon atoms two and three, giving a two-carbon fragment and a three-carbon fragment (55,56). In a similar manner, 2-ketoheptoses, such as sedoheptulose, would yield a two-carbon fragment (possibly phosphoglycolal) and a five-carbon fragment leading to the ketopentose. The question of the source of the seven-carbon heptose must then be answered. The rather obvious possibility of its formation by the condensation of a four- and three-carbon piece presents itself, and we are again faced with the problem of the character and identification of the four-carbon fragment which would be involved. The problem of the identification and character of this four-carbon fragment among the early products of steady state photosynthesis still remains as it did in all earlier schemes.

However, there is indication from paper chromatography of the presence of a phosphorylated erythronic acid among early products of photosynthesis. Since this compound is never present in very large concentrations, at least

under the conditions we have so far used for examination, it would indicate a very small steady state reservoir of this compound. This is true also of the corresponding sugar phosphate, viz., phosphoerythrose, which is thought to react with triose phosphate to give a sedoheptulose phosphate. It should be pointed out that in the regeneration of the two-carbon unit it is possible to bypass entirely the need for either four- or seven-carbon units as well as a second carboxylation reaction.⁹ This is done by using the recently revived (58,59) route of Dickens (60) from glucose to ribulose via 3-keto gluconic acid and a decarboxylation. However, there would be no net gain in reduced carbon in such a cycle and other ports of carbon dioxide entry would have to be provided.

The dotted arrow leading from triose directly to erythronic acid would correspond to the reductive carboxylation of dihydroxyacetone

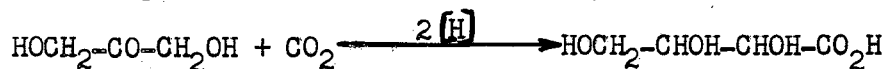

which is exactly analagous to the reductive β -carboxylation of pyruvic acid leading to malic acid. The existence of enzymes capable of performing the latter reaction has been demonstrated. Figure 4, of course, is designed to represent only the transformations occurring in the carbon skeleton. It awaits further definition by more extensive kinetic studies as well as isolations and degradations which are yet to be performed.

It is interesting to note and specifically point out here the further development of the basic idea of a very close interweaving of the wide variety of metabolic reactions, some of which might be conceived as being primarily associated with photosynthesis while others are usually, or more often, associated with respiratory and other biosynthetic transformations.

9 - The desirability of avoiding the second carboxylation reaction in photosynthesis was suggested by Gaffron and his co-workers some years ago (57).

It is clear, for example, how it might be possible for the products of carbon reduction formed in the closed cycle, shown above, to enter into the tricarboxylic acid cycle and thus produce high energy phosphate by already known mechanisms. It should be remembered that not shown in Figure 4 are the compounds giving the reducing power which would be required to drive such a cycle and which have their primary origin in the photochemical apparatus. It is also clear that a change in the rate of any one of the reactions shown would affect the stationary state concentrations of almost every compound shown there.

It is the development of such a conception as this, not only for the carbon dioxide cycle but for the oxygen evolution cycle as well, in specific chemical terms, which we feel sure will ultimately lead to the clear understanding of the enormous variety of observations on photosynthetic organisms and systems in general which was reported since the character of the phenomenon was first recognized.

REFERENCES

- (1) "Symposia of Chemical Transformation of Carbon in Photosynthesis," Fed. Proc., 2, June 1950.
- (2) A. A. Benson and M. Calvin, "CO₂ Fixation by Green Plants," Ann. Rev. of Plant Physiol., 1 (1950).
- (3) J. Franek, "A Critical Survey of the Physical Background of Photosynthesis," Ann. Rev. of Plant Physiol., 2, 53 (1951).
- (4) H. Gaffron and E. W. Fager, "The Kinetics and Chemistry of Photosynthesis," Ann. Rev. of Plant Physiol., 2, 87 (1951).
- (5) E. I. Rabinowitch, Photosynthesis II, Part 1 (1951), Interscience Publishers.
- (6) "CO₂ Fixation in Photosynthesis," Symp. of the Soc. Exper. Biol., V., Cambridge University Press. This symposium was held in Sheffield in July of 1950.
- (7) Conference on the Sun in the Service of Man. Proceedings of the American Academy of Arts and Sciences, 79, 4, (1951). This conference was held on February 24-25, 1951, and contains the general discussions of the possible application of photosynthesis and knowledge about photosynthesis rather than detailed information about its mechanism.
- (8) E. I. Rabinowitch, "Photosynthesis," Ann. Rev. of Phys. Chem., 2, (1951). This review admits to conferences as late as March 1951 but actually discusses much information which was not published at that time.
- (9) D. I. Arnon, Nature, 167, 1008 (1951).
- (10) A. H. Mehler, Arch. Biochem. and Biophys., 33, 1, 65 (1951).
- (11) L. J. Tolmach, Arch. Biochem. and Biophys., 33, 1, 120 (1951).
- (12) W. Vishniac and S. Ochoa, Nature, 167, 768 (1951).
- (13) E. A. Biochenko, Dokl. Akad. Nauk., SSSR, 70, 1037 (1950).
- (14) E. A. Biochenko and V. I. Baranov, Dokl. Akad. Nauk., SSSR, 78, 327 (1951).
- (15) E. V. Vereschinski, Biochemia, 16, No. 4, 350 (1951).
- (16) J. Spikes, Arch. Biochem. and Biophys., 35, (1952).
- (17) T. F. Andruva and L. E. Zubkovich, Dokl. Akad. Nauk., SSSR, 70, 525 (1950).
- (18) R. Hill and R. Scarisbrick, New Phytologist, 50, 1, 112 (1951).
- (19) K. Bhagvat and R. Hill, New Phytologist, 50, 1, 98 (1951).
- (20) A. A. Krasnovskii and K. K. Voynovskaya, Dokl. Akad. Nauk., SSSR, 81, 879 (1951).

- (21) L. M. Kosobutzkaya and A. A. Krasnovskii, Dokl. Akad. Nauk., SSSR, 74, 103 (1950).
- (22) A. A. Krasnovskii and G. P. Brin, Dokl. Akad. Nauk., SSSR, 73, 1239 (1950).
- (23) V. B. Evstigneev and V. A. Gavrilova, Dokl. Akad. Nauk., SSSR, 74, 781 (1950).
- (24) L.N.M. Duysens, Nature, 168, 548 (1951).
- (25) C. S. French and V. K. Young, J. Gen. Physiol., in press.
- (26) D. Burk and O. Warburg, Naturwissenschaften, 24, 560, 37 (1950).
- (27) D. Burk and O. Warburg, Fed. Proc., 10, 1, part 1 (1951).
- (28) D. Burk and O. Warburg, Zs. f. Naturf., 6B, 1, 12 (1951).
- (29) O. Warburg and D. Burk, Arch. Biochem. and Biophys., 25, 2, 410 (1950).
- (30) D. Burk, A. L. Schade, J. Hunter and O. Warburg, Symp. for Soc. of Exper. Biol., V, Carbon Dioxide Fixation and Photosynthesis, (1951) 312.
- (31) M. S. Nishimura, C. P. Whittingham and R. Emerson, Symp. for Soc. of Exper. Biol., V, Carbon Dioxide Fixation and Photosynthesis, 176 (1951).
- (32) E. I. Rabinowitch, Ann. Rev. Phys. Chem., "Photosynthesis," 2, 371 (1951).
- (33) E. I. Rabinowitch, Photosynthesis II, part 1, 1085-1118 (1951), Interscience Publishers.
- (34) O. Warburg, Zeitschrift fur Elektrochemie und angewandte physikalische Chemie, 55, 6, 447 (1951).
- (35) O. Warburg, H. Gelick and K. Briese, Zs. f. Naturf., 6B, 8, 417 (1951).
- (36) R. Van der Veen, Physiologia Plantarum, 4, 486 (1951).
- (37) A. H. Brown, A. O. Nier and R. W. Van Norman, Ann. Rev. Plant Physiol., 2, 89 (1951).
- (38) J. W. Weigl and M. Calvin, J. Am. Chem. Soc., 73, 5058 (1951).
- (39) S. Ruben, J. Am. Chem. Soc., 65, 279 (1943).
- (40) F. Lipmann, Currents in Biochemical Research, Ed. by D. E. Green, Interscience Publishers (1946), 137.
- (41) J. Franck, Photosynthesis II, Part 1 (1951), by E. I. Rabinowitch, Interscience Publishers.
- (42) A. A. Benson and M. Calvin, Science, 105, 648 (1947).

- (43) M. Calvin and A. A. Benson, Science, 107, 476 (1948).
- (44) M. Calvin and A. A. Benson, Cold Spring Harbor Symposia Quant. Biol. 13, 6 (1948).
- (45) B. L. Strehler and W. Arnold, J. Gen. Physiol., 34, 809 (1951).
- (46) B. L. Strehler, Arch. Biochem. Biophys., 34, 239 (1951).
- (47) A. A. Benson and M. Calvin, J. Exper. Botany, 1, 63 (1950).
- (48) H. Holzer, Z. Naturforsch, 6B, 424 (1951).
- (49) B. Kok, Biochemica et Biophysica Acta, 3, 625 (1949).
- (50) A. A. Benson, J. A. Bassham and M. Calvin, J. Am. Chem. Soc., 73, 1270 (1951).
- (51) A. A. Benson, J. Am. Chem. Soc., 73, 2971 (1951).
- (52) M. Calvin, The Harvey Lectures, Vol. 45, in press.
- (53) A. A. Benson, et al., J. Biol. Chem., in press.
- (54) A. A. Benson, S. Kawaguchi and M. Calvin, J. Am. Chem. Soc., in press.
- (55) D. A. Rappoport, H. A. Barker and W. Z. Hassid, Arch. Biochem. Biophys., 31, 326 (1951).
- (56) E. B. Fred, W. H. Peterson and A. J. Davenport, J. Biol. Chem., 39, 347 (1919); 42, 175 (1920); 53, 111 (1922). -I. V. van der Lek, Dissertation, Delft (1930). - M. J. Johnson, W. H. Peterson and E. B. Fred, J. Biol. Chem., 91, 570 (1931).
- (57) H. Gaffron, E. W. Fager and J. L. Rosenberg, "CO₂ Fixation in Photosynthesis", Symp. of the Soc. Exper. Biol., V., Cambridge University Press (1951).
- (58) B. L. Horecker and P. S. Smyrniotis, Arch. Biochem. and Biophys., 29, 232 (1950).
- (59) S. S. Cohen and D. B. McNair-Scott, J. Biol. Chem., 188, 509 (1951).
- (60) F. Dickens, Biochem. J., 32, 1626 (1938).

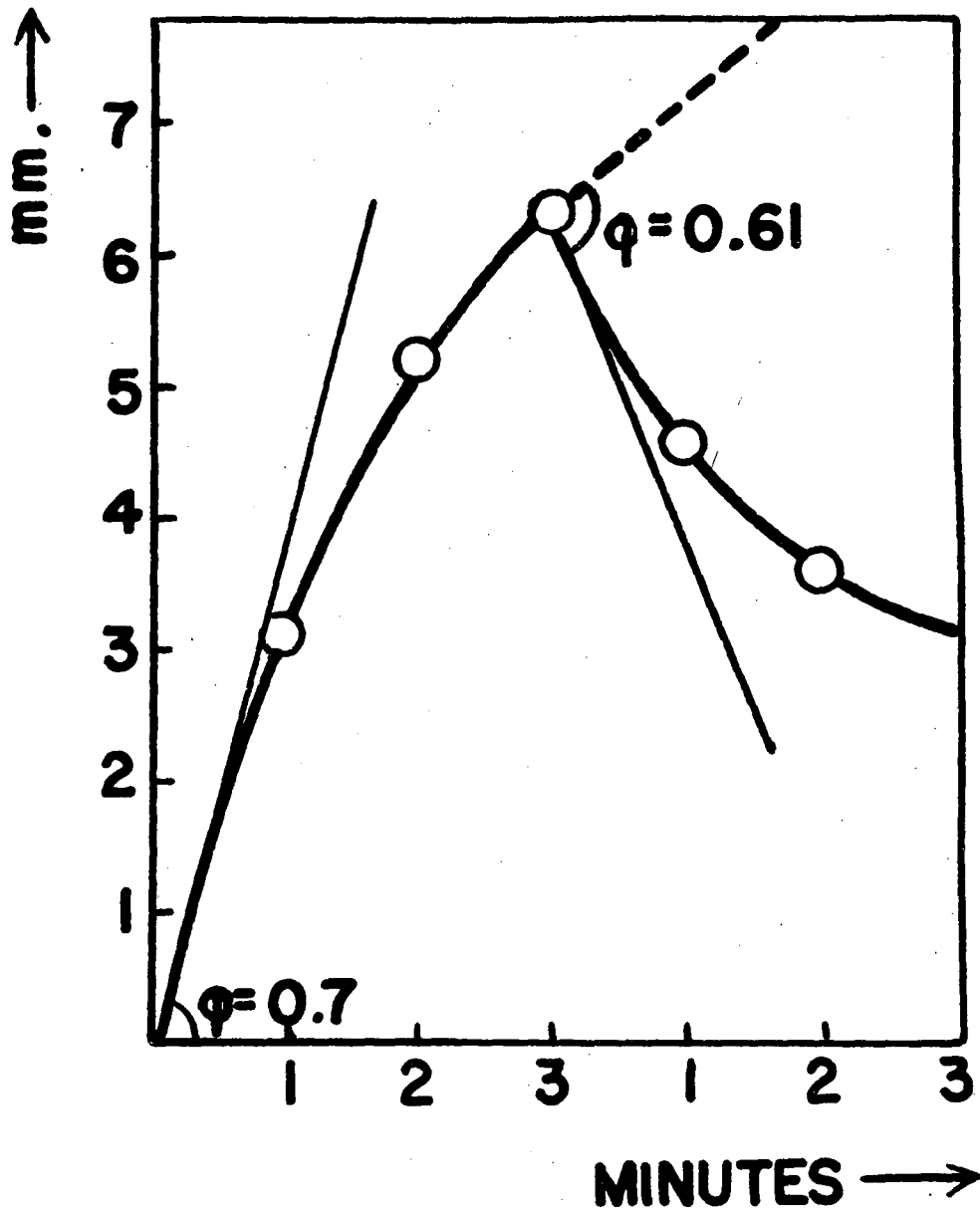

ZN 226

Fig. 1

Division of Photosynthesis into Light Reaction and Back Reaction.

100 mm³ of wet packed cells (Chlorella) suspended in 7 ml. water. Temperature = 20° C, light intensity of measured light 17.3 mm³ Quanta/min. or 2.8 x 10⁻³ watts at 546 mμ. Partial pressure of carbon dioxide = 0.109 atoms.

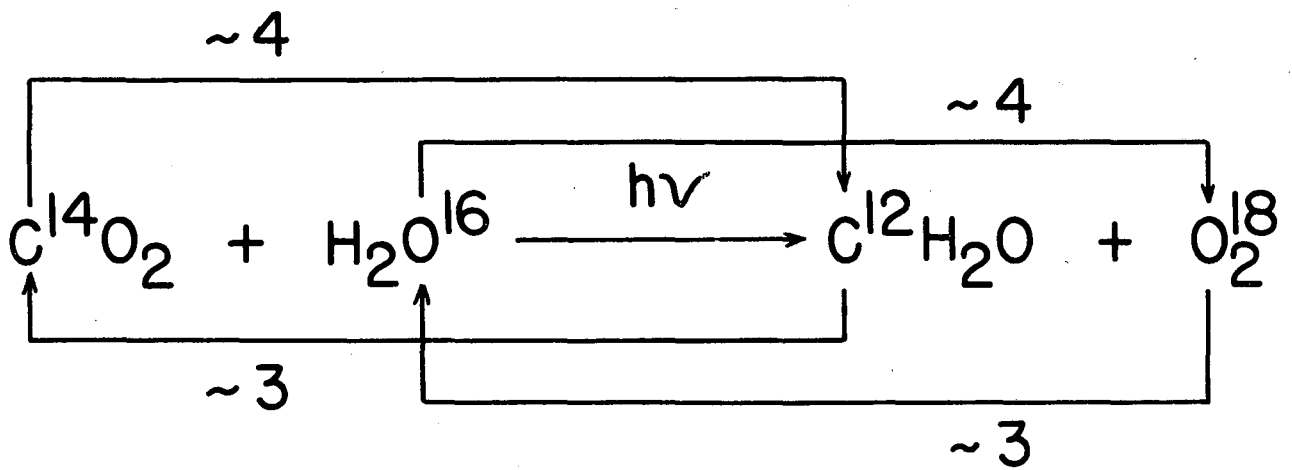

ZN227

Fig. 2

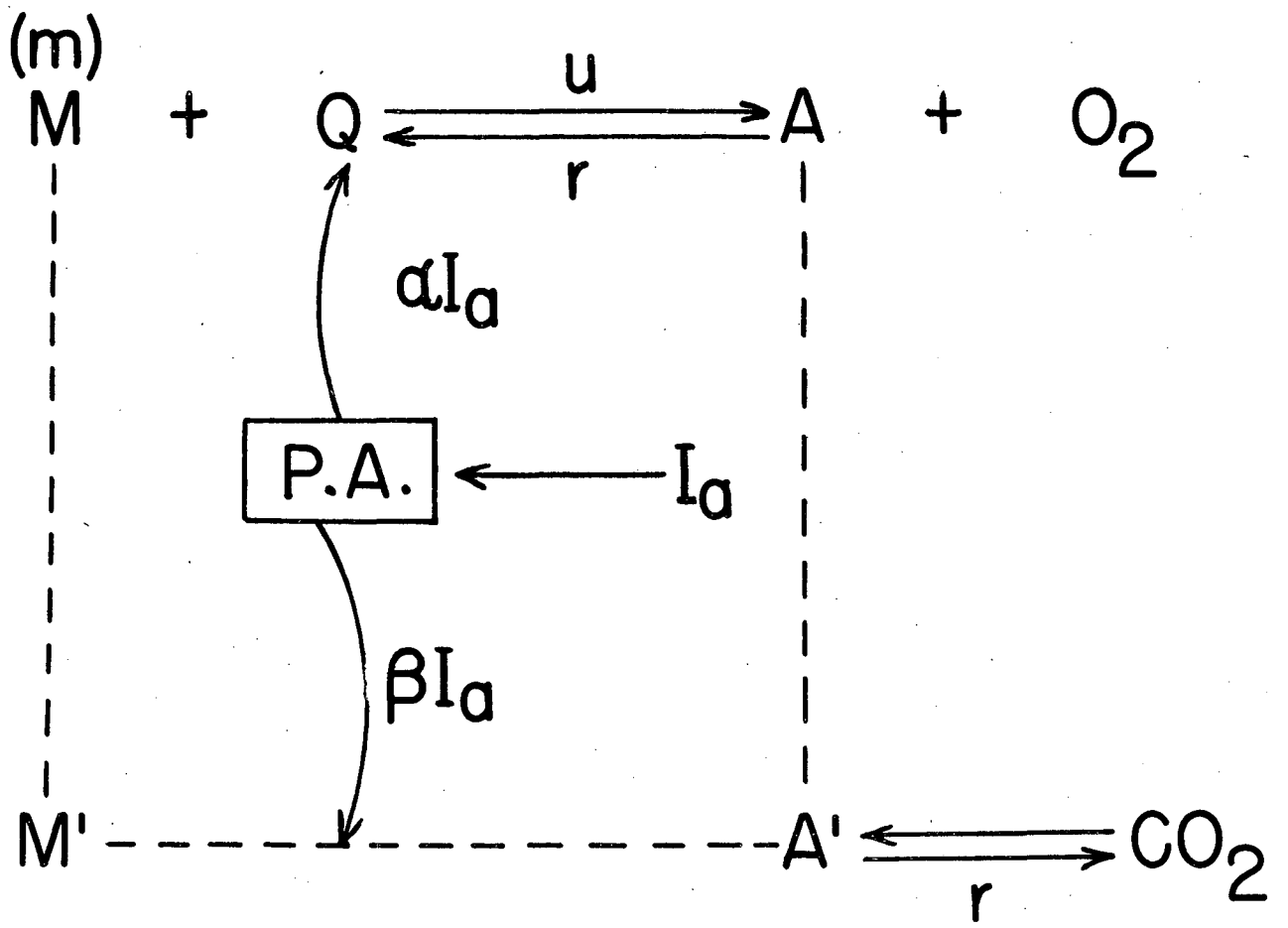

ZN228

Fig. 3

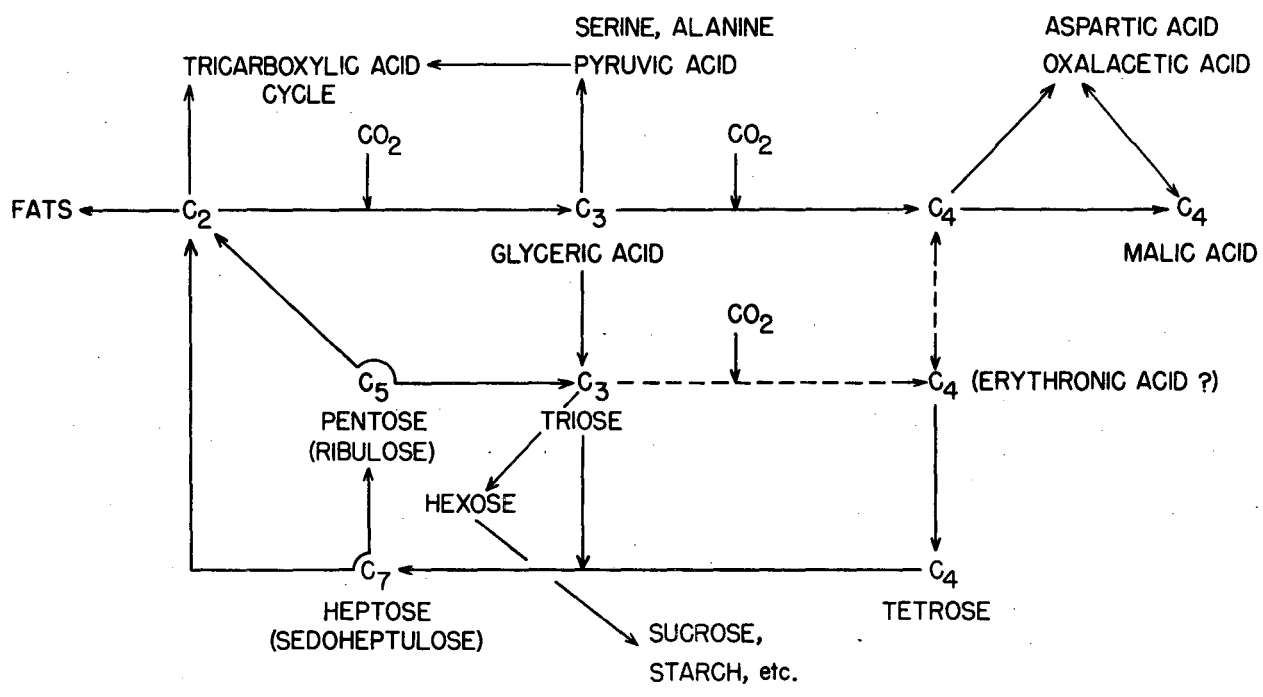

ZN 229

Fig. 4