

## **UC Santa Cruz**

### **UC Santa Cruz Previously Published Works**

**Title**

CDMA Implementation for Many-to-Many Cooperation in Mobile Ad Hoc Networks

**Permalink**

<https://escholarship.org/uc/item/4df7k6gt>

**Author**

Garcia-Luna-Aceves, J.J.

**Publication Date**

2007-05-28

Peer reviewed

# CDMA Implementation for Many-to-Many Cooperation in Mobile Ad Hoc Networks

Renato M. de Moraes<sup>1</sup>, Hamid R. Sadjadpour<sup>2</sup>, J.J. Garcia-Luna-Aceves<sup>3</sup>

<sup>1</sup>Department of Computing Systems – University of Pernambuco (UPE)  
Recife, PE 50720-001, Brazil

<sup>2</sup>Department of Electrical Engineering – University of California (UCSC)  
Santa Cruz, CA 95064, USA

<sup>3</sup>Dept. of Computer Engineering at UCSC and Palo Alto Research Center  
3333 Coyote Hill Road, Palo Alto, CA 94304, USA

renato@dsc.upe.br, {hamid, jj}@soe.ucsc.edu

***Abstract.** We describe a collaboration-driven approach to the sharing of the available bandwidth in wireless ad hoc networks, which we call many-to-many cooperation, that allows concurrent many-to-many communication. This scheme is based on the integration of multi-user detection and position-location information with frequency and code division in mobile ad hoc networks (MANETs). Transmissions are divided in frequency and codes according to nodal locations, and successive interference cancellation (SIC) is used at receivers to allow them to decode and use all transmissions from strong interfering sources. Many-to-many cooperation allows multi-copy relaying of the same packet, which reduces the packet delivery delay compared to single-copy relaying without any penalty in capacity.*

## 1. Introduction

Today, communication protocols used in ad hoc networks are meant to support reliable communication among senders and receivers that are *competing* with one another for the use of the common channel. This “competition-driven” view of bandwidth sharing has had profound implications on network architectures and methods used to access the channel and disseminate information. Gupta and Kumar showed that, in a wireless connected network with static nodes, the throughput for each node degrades as the number of nodes increases under the competition-driven view of networking [Gupta and Kumar 2000]. That is, it scales as  $\Theta(1/\sqrt{n \log(n)})$ ,<sup>1</sup> where  $n$  is the number of nodes in the network.

Grossglauser and Tse analyzed a two-hop, single-relay forwarding scheme for MANETs in which a source passes a packet to a relay that in turn delivers it to the destination when the two nodes are close to each other [Grossglauser and Tse 2001]. This and many subsequent studies on how to make MANETs scale by using mobility [Grossglauser and Tse 2001], [Bansal and Liu 2003], [de Moraes et al. 2004], [Gamal et al. 2004], consider each transmission as competing with all the other concurrent transmissions in the network. However, because a relay cooperates with a source by storing the source’s packet until it is close enough to the intended destination, the throughput of MANETs can be increased.<sup>2</sup>

<sup>1</sup>  $\Omega$ ,  $\Theta$  and  $O$  are the standard order bounds.  $\log(\cdot)$  is the natural logarithm.

<sup>2</sup> In [Grossglauser and Tse 2001], the per source-destination throughput scales as  $\Theta(1)$ .

Recently, Toumpis and Goldsmith have shown that the capacity regions for ad hoc networks are significantly increased when multiple access schemes are combined with spatial reuse (i.e., multiple simultaneous transmissions), multihop routing (i.e., packet relaying), and SIC, even without performing power control [Toumpis and Goldsmith 2003]. Also, SIC circuits with simple implementation and low complexity have been introduced recently [Patel and Holtzman 1994], and code division multiple access (CDMA) [Hanzo et al. 2003] and global positioning system (GPS) [Parkinson and Spilker 1996] technologies have been already integrated into a single IC chip [QUALCOMM 2004]. Although CDMA and SIC for ad hoc networks have been studied in the past [Rodoplu and Meng 2000], [Muqattash and Krunz 2003], [Hasan et al. 2003], [Negi and Rajeswaran 2004], prior approaches have assumed that each transmission competes with others.

These works [Gupta and Kumar 2000], [Rodoplu and Meng 2000], [Grossglauser and Tse 2001], [Bansal and Liu 2003], [Toumpis and Goldsmith 2003], [Muqattash and Krunz 2003], [Hasan et al. 2003], [Gamal et al. 2004], [Negi and Rajeswaran 2004], characterize a one-to-one communication approach which stems from cellular concepts and in our opinion, it is not appropriate for ad hoc networks. Our earlier work [de Moraes et al. 2004] describes a setting for one-to-many communication. In this scenario, a node relays its packet to multiple relay nodes that are close, allowing them to cooperate to search for the destination. In this scheme, however, all the transmitting nodes in each communication session compete with each other to transmit their packets. Ghez et al. [Ghez et al. 1989] and Tong et al. [Tong et al. 2001] explain a framework for many-to-one communication. In this context, multiple nodes cooperate to transmit their packets simultaneously to a single node using CDMA and the receiver node utilizes multiuser detection to decode multiple packets. Under this condition, two groups of multiple transmitting nodes that are close to each other have to compete with one another to transmit their packets to their respective receivers.

In [de Moraes et al. 2005] and [de Moraes et al. 2007], an approach to cooperative bandwidth sharing in MANETs was introduced which is called *many-to-many cooperation*.<sup>3</sup> It was proposed that with many-to-many cooperation, nodes access the available channel(s) and forward information across a MANET in such a way that concurrent transmissions become useful at destinations or relays. Hence, sender-receiver pairs collaborate, rather than compete, with others. Such framework characterizes a many-to-many communication in which a better network performance is possible.

In this paper, we detail the CDMA implementation for many-to-many cooperation introduced in [de Moraes et al. 2005] and [de Moraes et al. 2007]. Section 2 summarizes the basic network model that has been used recently to analyze the capacity of wireless networks [Gupta and Kumar 2000], [Grossglauser and Tse 2001], [Bansal and Liu 2003], [de Moraes et al. 2004], [Negi and Rajeswaran 2004]. Section 3 describes the many-to-many cooperation implementation. Section 4 addresses the communication capacity performance. Section 5 concludes the paper.

---

<sup>3</sup>By cooperation we mean that each node collaborates with his neighbors in relaying a packet for their destinations.

## 2. Network Model

The term *cell* denotes the set of nodes located inside a defined area of the network. The *receiver range*<sup>4</sup> of a node is defined as the radius, measured from the node, which contains all other nodes of the same cell. The *cluster* associated with a given node is the set of cells reached by the receiver range of this node.

Our assumptions are consistent with prior work [Gupta and Kumar 2000], [Grossglauser and Tse 2001], [Negi and Rajeswaran 2004]. Also, in this paper, nodes are considered to have SIC capability. The modeling problem we address is that of a MANET in which  $n$  mobile nodes move in a unit square area. To simplify our analysis, we assume that cells have square shapes, each with area equal to  $a(n) = \frac{1}{\phi n}$ , in which  $\phi \in (0, 1)$  is the cell area parameter of the network (see Fig. 1). We consider that the communication occurs only among those nodes that are close enough (i.e., in same cell), so that interference caused by farther nodes is low, allowing reliable communication. In other words, the receiver chooses the closest nodes because they present the best channel, in a respective order, due to the assumption of the simple path propagation model. Our model resembles the one introduced by Grossglauser and Tse [Grossglauser and Tse 2001], who consider a packet to be delivered from source to destination via one-time relaying.

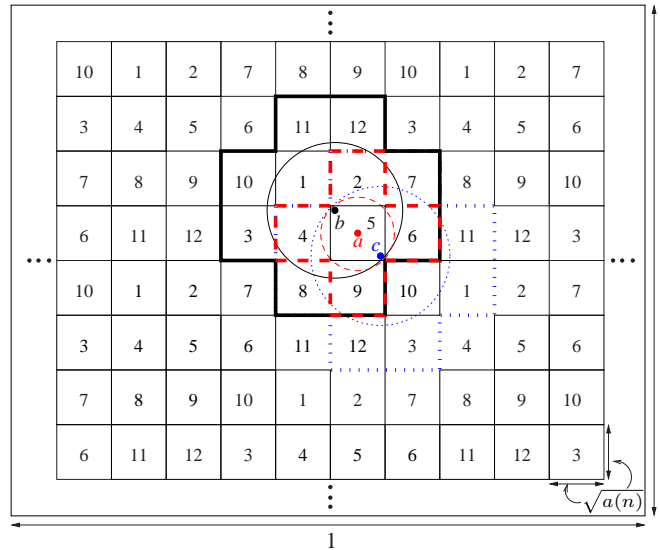

**Figure 1. Cells numbering in the unit square network.**  $a(n) = \frac{1}{\phi n}$  is the cell area. Each cell is associated to a control frequency bandwidth ( $\omega_1$  to  $\omega_{12}$ ) and to a PN sequence set ( $\xi_1$  to  $\xi_{12}$ ).

The position of node  $i$  at time  $t$  is indicated by  $X_i(t)$ . Nodes move according to the *uniform mobility model* [Bansal and Liu 2003], in which the steady-state distribution of the mobile nodes is uniform. Each node simultaneously transmits and receives data during a communication time period, through different frequency bands, since each data link is assumed half-duplex. This period of communication is called a *communication session* (or simply session). Furthermore, each session is divided into two parts. A neighbor discovery

<sup>4</sup>We adopt *receiver range* for a node because it is used here to distinguish constructive interference from destructive one (as described later), in contrast to the common use of *transmission range* as in [Gupta and Kumar 2000].

protocol is used by nodes during the first part to obtain their neighbors information (e.g., node identification (ID)), and the transmission of data is performed during the second part. Each node has a unique ID that does not change with time, and each node can simultaneously be a source (or relay) while transmitting and a destination (or relay) while receiving, during a session. Each source node picks a single arbitrary destination to whom it sends packets and this association does not change with time.

### 3. Many-to-Many Cooperation

In a competition-driven paradigm for MANETs, when two nodes become close enough to each other, they can transmit information to one another without any delay. With many-to-many cooperation, many nodes transmit concurrently to many other nodes that are close enough, and all such transmissions are decoded. Hence, a node may concurrently send to and receive from multiple nodes. Because full-duplex data communication in the same frequency band is not practical, we present a simple example of how many-to-many cooperation can be implemented with a hybrid scheme based on frequency division multiple access (FDMA) and CDMA that supports many-to-many communication. Therefore, to take advantage of SIC circuits at receivers, we use direct sequence CDMA (DS-CDMA) [Hanzo et al. 2003] with non-overlapping frequency bands (i.e., FDMA/CDMA<sup>5</sup>), in which distinct pseudo-noise (PN) sequences (or codes) are assigned to different nodes in the same region of the network.

#### 3.1. Bandwidth Allocation

We use two types of channels. *Control channels* are used by nodes to obtain such information as the IDs of strong interference sources, the data packet expected by destinations, and the state of data channels (by virtue of training sequences). Nodes employ conventional digital transceivers [Rappaport 2002] for the control channels. *Data channels* are used to transmit data taking advantage of SIC at the receivers. Thus, there are two separate transmitter (receiver) circuits in each node. One circuit is intended to transmit (receive) control packets, and the other is used to transmit (receive) data packets. Both circuits operate in different times and frequencies with respect to each other.

**Control (or Signaling) Channels:** Each cell is allocated a control frequency band from twelve non-overlapping control frequency bands required (and available),  $\omega_1$  to  $\omega_{12}$ , to enable frequency reuse while avoiding interference in the control channels from nearby cells. Each control frequency band  $\omega_i$  has a size of  $|\omega_i| = \Delta\omega$  for  $i = 1, \dots, 12$ . Hence, the total bandwidth required for the control channels is  $\Delta\omega_C = 12\Delta\omega$  (see Fig. 2).

The maximum number of cells in a cluster associated to a given node is twelve. The number of cells and the cluster shape are chosen such that if the receiver range has maximum value, i.e., almost  $\sqrt{2a(n)}$ , then the receiver range reaches all these cells (see Fig. 1). Also, two cells employing the same control frequency band are kept at least  $\sqrt{5a(n)}$  units away from each other, i.e., a safe guard-zone separation, thus guaranteeing asymptotic constant non-zero signal-to-noise and interference ratio (SNIR) as  $n \rightarrow \infty$  in the control channel, making signaling feasible and allowing control frequency reuse [de Moraes et al. 2004].

---

<sup>5</sup>Note that this hybrid FDMA/CDMA is one example to implement many-to-many cooperation. Other multiple access schemes can be also utilized which will not be discussed here.

Every node is assumed to know its own position (but not the position of any other node) by utilizing a GPS circuit [Parkinson and Spilker 1996], and to store a geographical map of the cells in the network with its associated control frequencies. The GPS is also used to provide an accurate common time reference to keep all nodes synchronized.

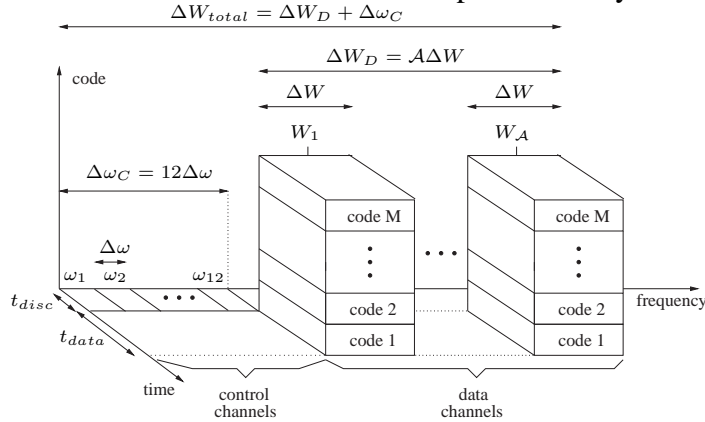

**Figure 2. Data and control channels spectra for the network.**

Each node uses the control channel receiver to listen to the control channel of the cell as well as to the other 11 control channels, in order to obtain the IDs and training sequences of the other nodes in its cell and in the cluster it perceives, while not transmitting during the neighbor discovery phase. In addition, while transmitting in the control channel of the cell, any node simultaneously uses its control channel receiver circuit to sense the cell control channel, for example, using echo cancelling techniques [Yamazaki et al. 1991], in order to detect collisions during its transmission in the neighbor discovery phase.

**Data Channels:** To allow code reuse in the data channels while reducing the negative effects of interference, each cell is allocated a set of PN sequences (or codes) from the twelve different code sets available,  $\xi_1$  to  $\xi_{12}$ , for communication in each data channel. Accordingly, each non-overlapping data channel is a half-duplex link of bandwidth  $\Delta W$ . If  $A$  is the maximum number of nodes allowed to communicate in any cell, then  $\Delta W_D = A\Delta W$  is the data bandwidth required for the entire network and  $M = 12A$  distinct PN sequences are needed for local data communication.  $M$  is also called the spreading factor (or processing gain). Also,  $\Delta W = BM$ , where  $B$  is the original data bandwidth before spreading [Hanzo et al. 2003].

Because a PN sequence can be associated to a sequence of bits [Hanzo et al. 2003], they can be ordered and grouped as follows.  $\xi_1 = \{C_1, \dots, C_A\}$ ,  $\xi_2 = \{C_{A+1}, \dots, C_{2A}\}$ , ...,  $\xi_{12} = \{C_{11A+1}, \dots, C_{12A}\}$ , in which  $C_i$  stands for the  $i^{th}$  PN sequence (or code). In this way, any set of twelve cells, numbered from 1 to 12, has a different set of codes. Therefore, by construction, the cluster seen by any node is composed of cells having distinct numbers, and consequently, different codes.

As we discuss in Section 3.2, the signaling in the control channel provides each node in a cell  $i$  knowledge of who the other nodes in this same cell are, and the node uses this information to choose a data channel to receive data, as well as to select a code for transmission from the available PN sequences in  $\xi_i$  based on its own and neighbor IDs, in the following order<sup>6</sup>: (i) The node with the highest ID in cell  $i$  is associated with the data

<sup>6</sup>For simplicity, we indicate  $W_j$  as the data channel associated to node  $j$ .

channel  $\Delta W$  centered at  $W_1$ , as well as it is assigned the first PN sequence in  $\xi_i$ . (ii) The node with the second highest ID in cell  $i$  is associated with the data channel  $\Delta W$  centered at  $W_2$ , as well as it is assigned the second PN sequence in  $\xi_i$ , and this continues for all nodes in cell  $i$ . (iii) The data channels not utilized become idle in cell  $i$ . It happens in those cells where the number of nodes is less than  $\mathcal{A}$ .

With the deployment illustrated in Fig. 1, two or more nodes, while moving in the same cell, can perceive clusters composed of different cells with at most twelve distinct numbers. For example, in the middle of Fig. 1, node  $a$ , located exactly at the center of the cell 5, can apply SIC to decode the data signal from node  $b$  and node  $c$  in that same cell, each one being almost  $\sqrt{a(n)}/2$  far apart from node  $a$  as shown (consequently, the receiver range for  $a$  is approximately  $\sqrt{a(n)}/2$  and it is indicated by the dashed circle). Node  $a$  perceives the cluster composed of the five cells  $\{2,4,5,6,9\}$  indicated in dashed line (i.e., those cells reached by  $a$ 's receiver range), and the other remaining closest four different cells  $\{1,7,8,10\}$  are not necessary for decoding purposes. However, node  $b$  has to decode signals from nodes  $a$  and  $c$  which is almost  $\sqrt{2a(n)}$  away (thus, the receiver range for  $b$  is approximately  $\sqrt{2a(n)}$  and it is indicated by the solid circle). Hence, node  $b$  perceives the cluster with all the twelve cells  $\{11,12,10,1,2,7,3,4,5,6,8,9\}$  shown in solid line, i.e., those cells reached by its receiver range. Analogously, node  $c$  perceives  $\{2,7,4,5,6,11,8,9,10,1,12,3\}$  illustrated in dotted line. Therefore, by construction, the cluster perceived by any node is composed of cells having distinct numbers, and consequently, different codes.

At time  $t$ , each cell has  $Z$  nodes such that the data communication is  $Z$ -to- $Z$ , i.e., many-to-many communication (see Fig. 3), where  $Z$  is a random variable. Each node employs a multi-user transmitter DS-CDMA [Hanzo et al. 2003] (i.e., it transmits up to  $Z - 1$  simultaneous data packets per session in which, due to FDMA, each packet is sent through a different data channel, as illustrated in Fig. 3(downlink)), spreading the data using the PN sequence associated to its ID. The node can transmit a different data packet in each channel or choose to send the same data packet in all (non-idle) channels, or a combination of both, depending on the fact that the node has packet for any destination in the same cell it is located. Thus, multi-copies of the same packet can be simultaneously relayed to reduce delay [de Moraes et al. 2004].

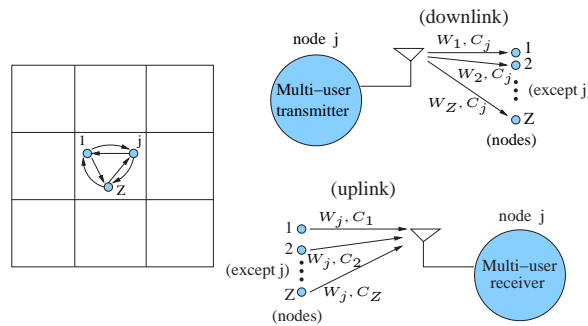

**Figure 3. Uplink and downlink description for data channels in a cell. Communication is  $Z$ -to- $Z$  (i.e., many-to-many).**

Given that each node is endowed with a multi-user detector (the SIC circuit) for its associated receiving data channel, it is able to decode the  $Z - 1$  simultaneous transmissions from all nodes in its cell (see Fig. 3(uplink)).

### 3.2. Channel Access

Access to the channel is controlled by the signaling that takes place over the control channels assigned to cells. Such signaling occurs simultaneously in all cells, without suffering high interference from each other because of the different frequency assignment and consequent safe guard-zone separation, as explained in Section 3.1.

The signaling among the nodes in the same cell must be one-to-many and cannot assume knowledge of who the nodes in a cell are, because nodes are mobile. Each node needs to inform the other nodes in its present cell about its own presence in the cell, plus other control information. We use a very simple approach that allow nodes to convey such control information with a high probability of success, even when the number of nodes in the network is large.

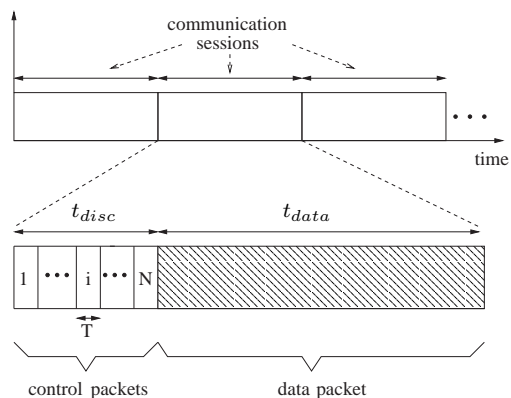

**Figure 4. Time series representation of control and data packets.  $t_{disc}$  is the neighbor discovery period.  $t_{data}$  is the time period for transmission of data.  $t_{disc}$  plus  $t_{data}$  form a communication session.**

As illustrated in Fig. 4, access to the channel is divided in time into a discovery phase and a data-transmission phase. The time period of “neighbor discovery”  $t_{disc}$  and the time period for transmission of data  $t_{data}$  are constant and independent of the number of nodes in the network ( $n$ ). Together, they compose a “communication session.” The common time reference for communication sessions is obtained through the GPS circuit. The values of  $t_{disc}$  and  $t_{data}$  are system design parameters.  $t_{disc}$  is subdivided into multiple slots, each of length  $T$ . Hence,  $T = \frac{t_{disc}}{N}$ , where  $N$  is a positive integer number to calculate according to some given criterion as explained later. For practical considerations, the overhead incurred by  $t_{disc}$  must be small compared to  $t_{data}$ . Each control packet conveys, as a minimum, the node ID, a short training sequence and the expected packet sequence number (SN), while a data packet bears long sequences of bits. Therefore, we assume that  $t_{disc} \ll t_{data}$ . Besides,  $\Delta\omega$  must be function of  $n$  in order to have  $t_{disc}$  not depending on  $n$ . Consequently, when  $n$  increases,  $\Delta\omega$  also increases such that  $t_{disc}$  remains constant [de Moraes et al. 2005].

Because each node simultaneously senses the channel to detect collision while transmitting in the control channel, the nodes involved in a collision do not participate in that session anymore, i.e., they remain silent until the next session. In addition, since only  $\mathcal{A}$  codes are available per cell, then, only the first  $\mathcal{A}$  nodes that successfully announced their control packets during the neighbor discovery phase are going to transmit (or receive) data during  $t_{data}$  right after  $t_{disc}$  for that session. Since this access is random and independent



from the node ID, thus, no privilege is given to a node with high ID value. From Section 3.1, the ID's are used only to order the code assignment in each cell.

Each time the discovery period is about to begin, each node randomly chooses one of the  $N$  mini-slots and transmits its control packet. If there is no collision, i.e., if the other nodes in the same cell choose different mini-slots to transmit, then all the other nodes in the cell will receive this packet. A collision happens every time two or more nodes in the same cell choose to transmit in the same mini-slot. The criterion used to choose  $N$  is such that the probability of collision remains small for practical values of  $\mathcal{A}$  [de Moraes et al. 2005].

### 3.3. Number of Communication Sessions

Now, the average number of communication sessions ( $H$ ) per node per cell is a function of the time the node moves in the cell. A node travels inside a cell on average every  $t_{trip}$  that is proportional to

$$t_{trip} \propto \Delta S/v(n) \implies t_{trip} = \Theta(\sqrt{a(n)}/v(n)), \quad (1)$$

where  $\Delta S = \Theta(\sqrt{a(n)})$  is the average distance traveled inside the cell. To model a real network in which a node would occupy a constant area, if the network grows, the entire area must grow accordingly. Therefore, because in our analysis we maintain the total area fixed, we must scale down the speed of the nodes. Consequently, the velocity of the nodes must decrease with  $\frac{1}{\sqrt{n}}$  [Gamal et al. 2004], [de Moraes et al. 2004]. Thus, since  $v(n) = \Theta(\frac{1}{\sqrt{n}})$  and  $\sqrt{a(n)} = \frac{1}{\sqrt{\phi n}}$ , from (1), it results that  $t_{trip}$  is indeed a constant. Hence, the average number of sessions  $H$  per node per cell is given by

$$H = t_{trip}/(t_{disc} + t_{data}) = c_1, \quad (2)$$

where  $c_1$  is a positive constant. Thus,  $H$  is a constant and does not depend on  $n$ . Therefore,  $t_{disc}$  and  $t_{data}$  must be chosen such that  $H \geq 1$ .

### 3.4. Packet Forwarding

Many-to-many cooperation employs a two-phase packet forwarding approach [Grossglauser and Tse 2001], which allows multiple one-time relays for the same packet which provides improved delay and reliability performance since multiple copies of the same packet look for the destination reducing delivery delay, and they also can serve as backups to protect against node failures [de Moraes et al. 2004].

We assume that each packet can be relayed in sequence at most once, such that the forwarding of any packet is composed of two phases (see Fig. 5(a)): The packet is transmitted from the source to possibly several relay nodes during *Phase 1*, and it is delivered later to its destination by only one of the relay nodes during *Phase 2*. Direct transmission from source to destination is also allowed. Both phases occur concurrently, but *Phase 2* has priority in all scheduled communications.

Note that more than one sender per cell may transmit concurrently. In Fig. 5(b), the four nodes  $i$ ,  $p$ ,  $j$ , and  $k$  are assumed to be in a same cell in the network. Our many-to-many cooperation scheme allows all the four nodes to send packets concurrently to each other. Each node can choose to *relay* the same packet to its neighbors or *deliver* a distinct packet to each different neighbor, or a combination of these two, depending on whether the node has queued packet *destined* to any of their neighbors. In this way, absolute priority is given to *Phase 2* for each packet.

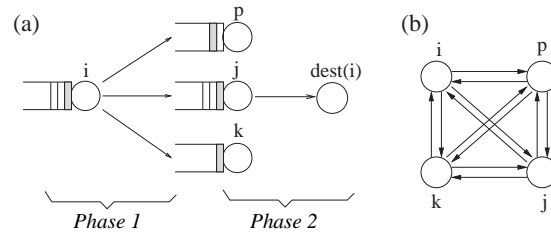

**Figure 5. Relaying scheme: (a) routing for a packet from node  $i$ : three packet copies of this packet are simultaneously relayed at Phase 1 in nodes  $p$ ,  $j$ , and  $k$ . Node  $j$  is assumed to be the first to find the destination, and delivers the packet at Phase 2. (b) many-to-many communication for nodes  $i$ ,  $p$ ,  $j$ , and  $k$ .**

For the multi-copy technique to work properly, the one-copy delivery of each data packet must be enforced [de Moraes et al. 2004]. For example, each data packet is assigned a destination identifier (DEST) and a sequence number (SN) in the header field. In each session, during the neighbor discovery phase, each node announces in the control channel its own identifier (ID). Furthermore, given that a node may be engaged with multiple sources as a destination, each node also includes in the control packet a table with the SNs expected from the sources with which it is associated. Accordingly, each node delivers a packet it holds to a destination only if it has the packet intended for the destination and its SN is greater than or equal to the SN announced by the destination. Nodes can discard those packets having SNs smaller than those announced by their destinations. If there is no destination around a node, it relays a new packet to all its neighbors. Each node compares the DEST of the received packet with the IDs of the other same cell nodes and drops the packet in case of match to avoid keeping a packet that is ahead being delivered to its destination.

### 3.5. Interference in a Data Channel

Although the nodes are synchronized, data packets are received at a given node asynchronously due to the different distances from each transmitting node. Besides, fading effects can amplify the asynchronous nature of packet reception. Thus, even if the codes are orthogonal, they exhibit partial cross-correlation at the receiver, which results in multiple access interference (MAI) [Hanzo et al. 2003].

The interference in the data channel at a node  $j$ , regarding node  $i$  transmitting to node  $j$  through  $W_j$ , is defined as the signals coming from all transmitting nodes in the network, via  $W_j$ , except node  $i$ . It can be decomposed in the following two types. *Destructive Interference (DEI)* for the node  $j$  comes from nodes, transmitting in  $W_j$ , outside the receiver range of  $j$ . *DEI* constitutes the part of the interference that will not be decoded. *Constructive Interference (COI)* comes from nodes, transmitting in  $W_j$ , within the receiver range of  $j$ . By construction (see Section 3.1), the nodes within the receiver range of  $j$ , transmitting in  $W_j$ , use different codes exhibiting partial cross-correlation due to the asynchronous nature of the uplink channel [Hanzo et al. 2003]. *COI* constitutes the decodable part of the interference.

If node  $i$  transmits data to  $j$  at time  $t$ , via  $W_j$ , the SNIR at the receiver  $j$ , without SIC, is given by (3) [Grossglauser and Tse 2001], where  $range^7$  is the set of nodes transmitting in  $W_j$  and reached by the receiver range of node  $j$ ,  $C_i$  is the PN sequence used by sender

<sup>7</sup>  $k \notin range$  means the nodes outside the receiver range of node  $j$  transmitting in  $W_j$ .

node  $i$ ,  $P_{ij}(t) = P \forall (i, j)$  is the transmit power chosen by node  $i$  to transmit to node  $j$  (i.e.,  $P_{ij}(t)$  is constant for all pair  $(i, j)$ ),  $g_{ij}(t)$  is the channel path gain from node  $i$  to  $j$ ,  $B$  is the original bandwidth of the data signal (before spreading),  $BN_0$  is the noise power (where  $N_0$  is the noise power spectral density),  $M$  is the spreading factor,  $COI$  and  $DEI$  are the total interference in  $W_j$  at node  $j$ . The summation terms in the denominator of (3) containing the factor  $1/M$  constitute the multiple access interference ( $MAI$ ) [Hanzo et al. 2003], and the last summation term (without the factor  $1/M$ ) is consequence of code reuse in the network and we call it *same code interference* ( $SCI$ ). Thus,  $SCI = \sum_{\substack{k \notin range \\ C_k = C_i}} P_{kj}(t)g_{kj}(t)$ , such that,  $MAI + SCI = COI + DEI$ .  $MAI$  and  $SCI$  presentations are easier for calculating SNIR [de Moraes et al. 2005], [de Moraes et al. 2007].

$$SNIR = \frac{P_{ij}(t)g_{ij}(t)}{BN_0 + \underbrace{\frac{1}{M} \sum_{\substack{k \in range \\ k \neq i}} P_{kj}(t)g_{kj}(t)}_{COI} + \underbrace{\frac{1}{M} \sum_{\substack{k \notin range \\ C_k \neq C_i}} P_{kj}(t)g_{kj}(t) + \sum_{\substack{k \notin range \\ C_k = C_i}} P_{kj}(t)g_{kj}(t)}_{DEI}}. \quad (3)$$

The channel path gain  $g_{ij}$  is assumed to be a function of the distance only (i.e., the simple path propagation model) [Gupta and Kumar 2000], [Grossglauser and Tse 2001], therefore,  $g_{ij}(t) = \frac{1}{|X_i(t) - X_j(t)|^\alpha} = \frac{1}{r_{ij}^\alpha(t)}$ , in which  $\alpha$  is the path loss parameter, and  $r_{ij}(t)$  is the distance between  $i$  and  $j$ .

### 3.6. FDMA/CDMA Transmitter Scheme

The FDMA/CDMA transmitter scheme for a node  $j$  is shown in Fig. 6(a). All packets previously relayed to node  $j$  are stored in the *buffer for relayed packets*. In each session, after the discovery phase, node  $j$  knows who are its neighbors in the cell it is located and load the *buffer for destination packets* if it has packet for each destination in the cell. Each packet signal  $p_x$  coming from the *banks of buffers* passes through a switch  $S_x$ , for integer  $x \in [1, \mathcal{A}]$ . After  $S_x$ , the signal is spread by the code  $C_j$  assigned to node  $j$ . The outcome is modulated by the frequency carrier associated to the node the packet is intended to. Finally, all modulated signals are summed up and transmitted through the antenna (see also Fig. 3(downlink)).

The *banks of buffers* not only store the packets relayed by node  $j$  but also packets generated locally by node  $j$ . The position of each switch  $S_x$  is chosen according to the existence of the destination node (assigned to  $W_x$ ) for the packet  $p_x$ , in the same cell  $j$  is moving. Accordingly, the switch  $S_x$  gives priority to the packet in the *buffer for destinations*. If the node assigned to the data channel  $W_x$  is not a destination for a relayed packet, then the switch selects the new packet ( $p_j$ ) generated locally by node  $j$ . Furthermore, if no node is assigned to the data sub-spectrum  $W_x$  in the cell that  $j$  is located, then  $S_x$  is set to 0 (ground) and no information is transmitted, contributing no increase in the interference through this data channel. Therefore, the objective of the switches is to give absolute priority to the *delivery* of packets (i.e., *Phase 2*) as described in Section 3.4, and prevent any unnecessary transmission of data through an idle data channel in the cell.

Note that the packet generated locally in node  $j$  is transmitted to those nodes that are not destinations. In this way, multi-copies of the same packet generated locally at  $j$  can be relayed to other nodes in the same cell [de Moraes et al. 2004].

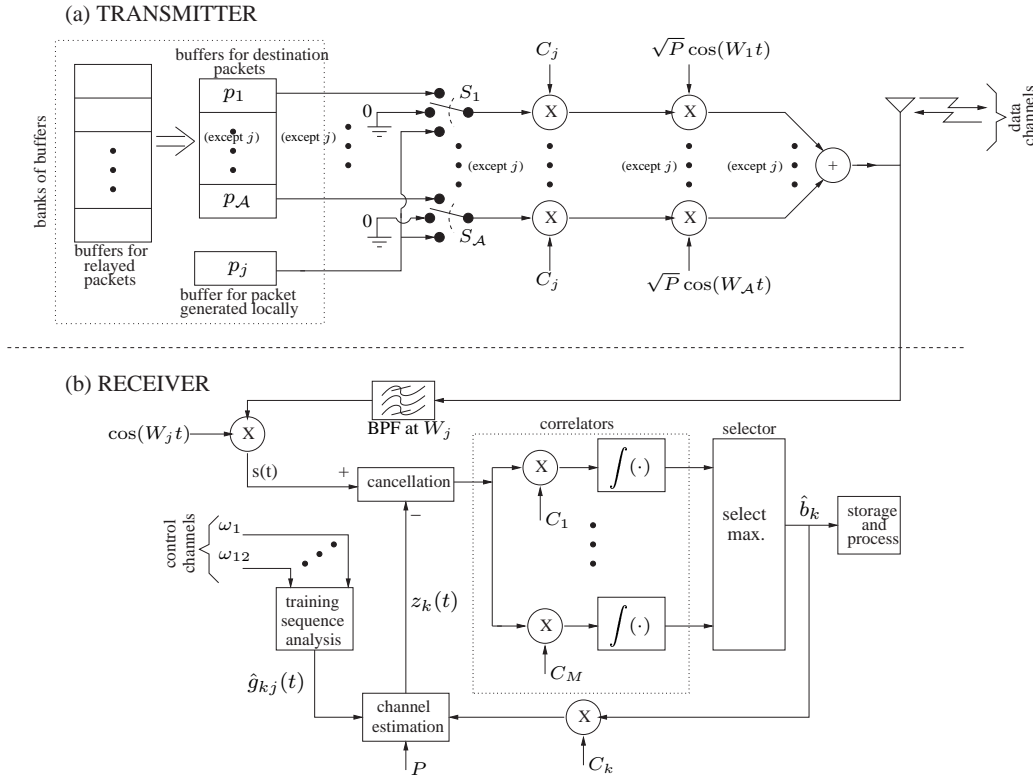

**Figure 6. Hybrid FDMA/CDMA data transceiver scheme for node  $j$ . (a) FDMA/CDMA transmitter. (b) CDMA successive interference cancellation receiver.**

### 3.7. CDMA-SIC Receiver Scheme

The basic decoding scheme of the CDMA-SIC receiver circuit is illustrated in Fig. 6(b) (see also Fig. 3(uplink)). The signal coming from the antenna passes through a band pass filter (BPF) centered at  $W_j$  which selects only the data channel  $\Delta W$  associated to  $j$ . The filtered signal is demodulated to the baseband spectrum. The received baseband data signal  $s(t)$  is subtracted (in the *cancellation* block) from an estimation locally generated  $z_k(t)$ , and fed into a bank of *correlators*. Each correlation is performed by using a distinct PN sequence. A *selector* decides which output from the correlators is the highest. This operation is also known as maximum a posteriori (MAP). The decoding is performed successively from the strongest signal to the weakest. Thus, with the simple path propagation model assumed, the strongest signal decoded first comes from the closest neighbor to node  $j$  (not necessarily in the same cell of  $j$  but in the cluster it perceives), while the weakest (decoded last) is the farthest node to node  $j$  in the cell node  $j$  is located. After decision in *selector*, the estimated decoded data bits  $\hat{b}_k$ , associated to node  $k$ , are stored for further processing and are also locally re-encoded using the associated PN sequence  $C_k$ ; Therefore, it results in  $z_k(t)$ , the locally baseband re-generated signal using an estimation  $\hat{g}_{kj}(t)$  of the channel related to node  $k$ . The *channel estimation* can be obtained, for example, by the receiving node listening in the control channels ( $\omega_1$  to  $\omega_{12}$ ), during the neighbor discovery phase, in which each node transmits a training sequence (or even a pilot signal) in the control packet such that each receiver can estimate the attenuation incurred in the data channel from each node, assuming that the control and data channels incur similar propagation effects. This entire

SIC process is repeated until all signals from the nodes in the same cell are successfully obtained. We assume that the processing time required to perform the SIC operation is negligible compared to each data bit duration.

Note that, depending on the position of the node  $j$ , it may have nodes transmitting from adjacent cells closer than a far node in the same cell. Therefore,  $j$  has to be able to decode the data signals from these adjacent cell nodes before decoding the signal from the far node of the same cell. This explains why each node also needs to obtain the training sequences from the other nodes located outside its cell but still within its receiver range. The receiver uses the information obtained during the neighbor discovery phase to retain the data packets from nodes in the same cell as  $j$ , dropping the outside cell packets since node  $j$  cannot keep track of all nodes in adjacent cells to see if this packet is for relaying or destination.

## 4. Link Capacity and Throughput

### 4.1. Link's Shannon Capacity

The link's Shannon capacity  $R_{ij}$  in the data channel  $W_j$ , in which node  $j$  receives from node  $i$ , after  $j$  applying SIC up to node  $i$ , from (3), is given (in units of nats) by [Cover and Thomas 1991]

$$R_{ij} = B \log(1 + SNIR). \quad (4)$$

In [de Moraes et al. 2005] and [de Moraes et al. 2007], a detailed analysis for calculating the SNIR was performed. It was shown that if the expansion  $B = f(n)$  of the original data bandwidth is considered, such that  $1 \leq f(n) < n^{\frac{\alpha}{2}}$ , then, a lower-bound for  $R_{ij}$  can be obtained  $R_{ij} \geq c_2 f(n)$ , in which  $c_2$  is a positive constant for a given set of network parameters. In this case, interference dominates noise for the bandwidth expansion  $1 \leq B < n^{\frac{\alpha}{2}}$ .

On the other hand, if we consider a scenario such that there is no limitation on available bandwidth, then we can obtain an upper-bound for  $R_{ij}$  for a large bandwidth expansion  $B \geq c_3 n^{\frac{\alpha}{2}}$ , i.e.,  $R_{ij} \leq c_4 n^{\frac{\alpha}{2}}$ , for some positive constant  $c_3$ . Here, noise dominates interference due to the large bandwidth expansion.

Thus, we have two limiting cases. The former is the minimum capacity attained if we use the bandwidth expansion  $1 \leq B < n^{\frac{\alpha}{2}}$ . The latter is the maximum capacity reachable if the available bandwidth is large such that  $B \geq c_3 n^{\frac{\alpha}{2}}$ . Note that any increase in  $B$  beyond  $c_3 n^{\frac{\alpha}{2}}$  will not change the order of the upper-bound of the capacity.

### 4.2. Per Source-Destination Throughput

From Section 3.2, each node accesses the data channel at a constant rate  $\delta = \frac{t_{data}}{t_{disc} + t_{data}}$  with probability approaching 1 as  $n \rightarrow \infty$ , such that each source sends one packet per session to its destination. Each node is guaranteed, in each data channel, a communication rate of  $R_{ij}$  lower- and upper-bounded by  $f(n)$  and  $c_4 n^{\frac{\alpha}{2}}$ , respectively. Also, this available communication rate has to be divided among all routes the node must serve per session per channel. However, due to the mobility and the routing scheme, each node serves only one route per session per data channel, i.e., the node either relays a new packet or it delivers a packet to a destination. Thus, the number of routes every node has to service per session per data channel is (# of served routes) = 1. Moreover, all cells containing at least two nodes are able to execute FDMA/CDMA and SIC successfully. From [de Moraes et al. 2005],

$\mathbb{P}\{Z \geq 2\} = (1 - e^{-1/\phi} - \frac{1}{\phi}e^{-1/\phi})$ , as  $n \rightarrow \infty$ . Hence, with probability approaching 1 as  $n \rightarrow \infty$ , the per source-destination throughput  $\lambda(n)$  is obtained by [Gamal et al. 2004]

$$\lambda(n) = \frac{R_{ij} \delta \mathbb{P}\{Z \geq 2\}}{\# \text{ of served routes}} = c_5 R_{ij}, \quad (5)$$

where  $c_5$  is a positive constant for given  $t_{disc}$ ,  $t_{data}$ , and  $\phi$ . From (5) and the bounds obtained for  $R_{ij}$  the following Theorem is proved [de Moraes et al. 2005], [de Moraes et al. 2007].

**Theorem 1** *By employing mobility, CDMA, SIC, one-time relaying of packets, and bandwidth expansion using many-to-many cooperation, the ad hoc network attains, with probability approaching 1 as  $n \rightarrow \infty$ , the upper- and lower-bound per source-destination throughput given respectively by  $\lambda(n) = O(n^{\frac{\alpha}{2}})$  and  $\lambda(n) = \Omega[f(n)]$ , where  $1 \leq f(n) < n^{\frac{\alpha}{2}}$ .*

In [de Moraes et al. 2005] and [de Moraes et al. 2007], the many-to-many communication performance is compared with previous schemes, showing that with similar bandwidth expansion, our approach outperforms other existing techniques.

## 5. Conclusions

A CDMA scheme together with successive interference cancellation was described which allows concurrently many-to-many communication in mobile ad hoc networks. Shannon capacity and per source-destination throughput can be increased in wireless ad hoc networks by employing mobility, FDMA/CDMA, SIC, and one-time relaying of packets taking advantage of many-to-many cooperation among nodes. Such performance is attained by using successive interference cancellation and distinct codes among close neighbors, which is enabled by running a simple neighbor-discovery protocol. Accordingly, interference from close neighbors is no longer harmful, but rather endowed with valuable data that we can take advantage of. This technique also allows for code reuse and it was shown that we can obtain Shannon capacity and per source-destination throughput increasing with the total number of nodes  $n$ . In addition, because multi-copy relaying of packets is employed, the delay performance is improved and follows the description given in [de Moraes et al. 2004]. Future work will consider power control and energy consumption limitations.

## Acknowledgment

This work was supported in part CAPES/Brazil, by the US Army Research Office under grant W911NF-05-1-0246 and by the Basking Chair of Computer Engineering. Opinion, interpretations, conclusions and recommendations are those of the authors and are not necessarily endorsed by the US Department of Defense.

## References

- Bansal, N. and Liu, Z. (2003). Capacity, delay and mobility in wireless ad-hoc networks. In *Proc. of IEEE Infocom*, San Francisco, California.
- Cover, T. M. and Thomas, J. A. (1991). *Elements of Information Theory*. John Wiley & Sons.
- de Moraes, R. M., Sadjadpour, H. R., and Garcia-Luna-Aceves, J. (2007). Many-to-many communication: A new approach for collaboration in manets. In *Proc. of IEEE Infocom*, Anchorage, Alaska.

- de Moraes, R. M., Sadjadpour, H. R., and Garcia-Luna-Aceves, J. J. (2004). Throughput-delay analysis of mobile ad-hoc networks with a multi-copy relaying strategy. In *Proc. of IEEE SECON*, Santa Clara, California.
- de Moraes, R. M., Sadjadpour, H. R., and Garcia-Luna-Aceves, J. J. (2005). A new communication scheme for MANETs. In *Proc. of IEEE WirelessCom*, Maui, Hawaii.
- Gamal, A. E., Mammen, J., Prabhakar, B., and Shah, D. (2004). Throughput-delay trade-off in wireless networks. In *Proc. of IEEE Infocom*, Hong Kong.
- Ghez, S., Verdu, S., and Schwartz, S. (1989). Optimal decentralized control in the random access multipacket channel. *IEEE Trans. on Automatic Control*, 34(11):1153–1163.
- Grossglauser, M. and Tse, D. (2001). Mobility increases the capacity of wireless ad-hoc networks. In *Proc. of IEEE Infocom*, Anchorage, Alaska.
- Gupta, P. and Kumar, P. R. (2000). The capacity of wireless networks. *IEEE Transactions on Information Theory*, 46(2):388–404.
- Hanzo, L., Yang, L.-L., Kuan, E.-L., and Yen, K. (2003). *Single- and Multi-Carrier DS-SS-CDMA Multi-User Detection, Space-Time Spreading, Synchronisation, Networking and Standards*. John Wiley & Sons.
- Hasan, A., Yang, K., and Andrews, J. G. (2003). High-capacity CDMA ad hoc networks without closed-loop power control. In *Proc. of IEEE MILCOM*, Boston, Massachusetts.
- Muqattash, A. and Krunz, M. (2003). CDMA-based MAC protocol for wireless ad hoc networks. In *Proc. of ACM MobiHoc*, Annapolis, Maryland.
- Negi, R. and Rajeswaran, A. (2004). Capacity of power constrained ad-hoc networks. In *Proc. of IEEE Infocom*, Hong Kong.
- Parkingson, B. W. and Spilker, J. J. (1996). *Global Positioning System: Theory and Applications Vol. I*. American Institute of Aeronautics and Astronautics, Inc.
- Patel, P. and Holtzman, J. (1994). Analysis of a simple successive interference cancellation scheme in a DS/CDMA system. *IEEE Journal on Sel. Areas in Comm.*, 12(5):796–807.
- QUALCOMM (2004). *RFR3300 RF-to-IF Receiver*. QUALCOMM Inc.
- Rappaport, T. S. (2002). *Wireless Communications: Principles and Practice*. Prentice Hall.
- Rodoplu, V. and Meng, T. H. (2000). Position based CDMA with multiuser detection (P-CDMA/MUD) for wireless ad hoc networks. In *Proc. of IEEE Int. Symp. on Spread-Spectrum Tech. & Appli.*, New Jersey.
- Tong, L., Zhao, Q., and Mergen, G. (2001). Multipacket reception in random access wireless networks: From signal processing to optimal medium access control. *IEEE Communications Magazine*, pages 108–112.
- Toumpis, S. and Goldsmith, A. J. (2003). Capacity regions for wireless ad hoc networks. *IEEE Trans. on Wireless Comm.*, 2(4):736–748.
- Yamazaki, K., Aly, S., and Falconer, D. (1991). Convergence behaviour of a jointly adaptive transversal and memory-based echo canceller. *IEE Proceedings F Radar and Signal Processing*, 138(4):361–370.