

Lawrence Berkeley National Laboratory

LBL Publications

Title

Techniques for Identifying and Measuring Higher Order Modes in RF Cavities

Permalink

<https://escholarship.org/uc/item/4dq7q6bp>

Authors

Goldberg, D A

Rimmer, R A

Publication Date

1997-05-01



ERNEST ORLANDO LAWRENCE BERKELEY NATIONAL LABORATORY

Techniques for Identifying and Measuring Higher Order Modes in RF Cavities

D.A. Goldberg and R.A. Rimmer
Accelerator and Fusion
Research Division

May 1997

Submitted to
Nuclear Instruments and Methods
in Physics Research A



REFERENCE COPY
Does Not Circulate
Bldg. 50 Library - Ref.
Lawrence Berkeley National Laboratory

DISCLAIMER

This document was prepared as an account of work sponsored by the United States Government. While this document is believed to contain correct information, neither the United States Government nor any agency thereof, nor The Regents of the University of California, nor any of their employees, makes any warranty, express or implied, or assumes any legal responsibility for the accuracy, completeness, or usefulness of any information, apparatus, product, or process disclosed, or represents that its use would not infringe privately owned rights. Reference herein to any specific commercial product, process, or service by its trade name, trademark, manufacturer, or otherwise, does not necessarily constitute or imply its endorsement, recommendation, or favoring by the United States Government or any agency thereof, or The Regents of the University of California. The views and opinions of authors expressed herein do not necessarily state or reflect those of the United States Government or any agency thereof, or The Regents of the University of California.

Ernest Orlando Lawrence Berkeley National Laboratory
is an equal opportunity employer.

DISCLAIMER

This document was prepared as an account of work sponsored by the United States Government. While this document is believed to contain correct information, neither the United States Government nor any agency thereof, nor the Regents of the University of California, nor any of their employees, makes any warranty, express or implied, or assumes any legal responsibility for the accuracy, completeness, or usefulness of any information, apparatus, product, or process disclosed, or represents that its use would not infringe privately owned rights. Reference herein to any specific commercial product, process, or service by its trade name, trademark, manufacturer, or otherwise, does not necessarily constitute or imply its endorsement, recommendation, or favoring by the United States Government or any agency thereof, or the Regents of the University of California. The views and opinions of authors expressed herein do not necessarily state or reflect those of the United States Government or any agency thereof or the Regents of the University of California.

LBNL-40290
CBP Note-230

**Techniques for Identifying and Measuring Higher Order Modes
in RF Cavities***

D. A. Goldberg and R. A. Rimmer
Lawrence Berkeley National Laboratory
University of California
Berkeley, California 94720

May 1997

submitted to *Nuclear Instruments & Methods*

* This work was supported by the Director, Office of Energy Research, Office of High Energy and Nuclear Physics, High Energy Physics Division, of the U. S. Department of Energy, under Contract No. DE-AC03-76SF00098.

Techniques for Identifying and Measuring Higher Order Modes in RF Cavities

D. A. Goldberg and R. A. Rimmer

*Lawrence Berkeley National Laboratory
1 Cyclotron Road
Berkeley, California 94720*

We report on a number of techniques which can be used to unravel the higher-order-mode spectrum of an RF cavity. Most of these techniques involve the application of basic symmetry principles and require for their application only that the cavity exhibit some basic symmetry, possibly broken by the presence of couplers, apertures, etc., which permits a classification of these modes in terms of some property characterized by that symmetry, e.g., multipolarity for a cavity which is basically a figure of revolution. Several examples of the application of these techniques are given.

INTRODUCTION

With the growing number of high-current accelerators, the problem of beam impedance has become increasingly important. One of the major sources of beam impedance is the large number of higher-order modes (HOM's) in the RF cavities. For successful machine operation it is necessary to damp many of these modes, a prerequisite for which is their identification. In the course of a recent study, involving the RF cavities for the PEP-II B-factory [1], we have developed a number of techniques for the identification and measurement of HOM's. In the belief that others working on similar problems might benefit from our experience, and the hope that they might be spared the necessity of "re-inventing the wheel," we offer the present summary of those techniques.

Throughout the discussion it will be assumed that the cavity can be approximately characterized by some symmetry for which a classifiable set of excitation modes exist (e.g., a figure of revolution whose modes are classifiable according to their multipolarity). We further assume a one-to-one correspondence between these idealized modes and the modes of the actual cavity, although we will point out instances where this latter assumption may break down.

To illustrate for the non-specialist the complexity of the problem, we present in Fig. 1 a portion of the spectrum of the prototype PEP-II cavity. The dashed curve shows the spectrum obtained when the asymmetries in the cavity are removed (through the use of conducting tape and appropriate port-plugging devices) to make it into a figure of revolution; the solid curve

shows the spectrum for the cavity with all symmetry-breaking apertures open, but with the HOM-damping loads absent. Observations on the discrepancies between the two spectra, as well as explanations of the mode labels will be made in succeeding sections of the paper; suffice it to say for now that although there are obvious correspondences between the spectra, a complete identification of the modes in the actual cavity is clearly a non-trivial task.

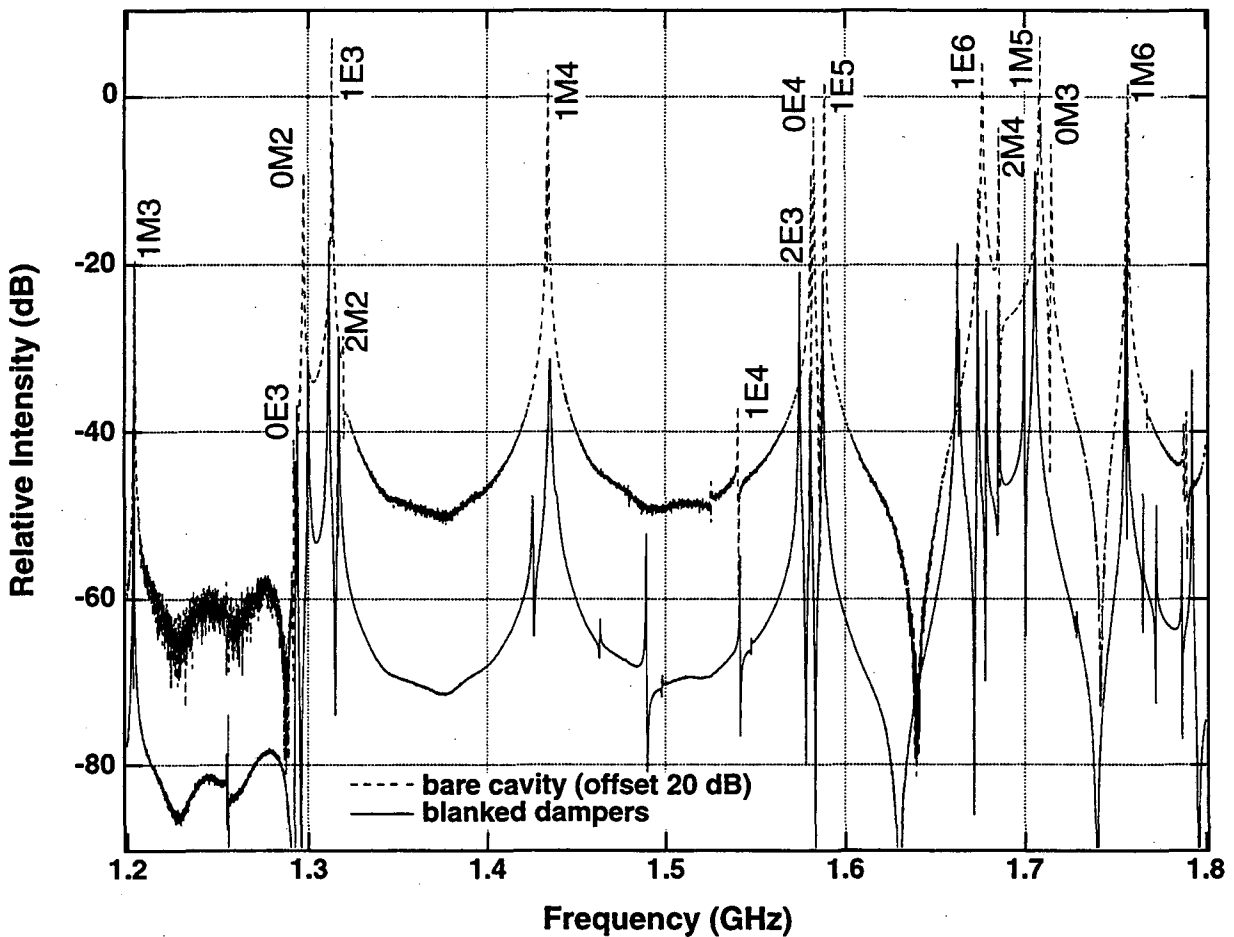

Fig. 1. Spectra of the "bare" cavity (offset by 20 dB for clarity) and the cavity with all symmetry-breaking ports open. The bare-cavity peaks are labeled with the mode designation obtained from the modeling code URMEL (see text).

By way of a final introductory note, the reader will no doubt note the presence of an unusually large number of footnotes in this article. This is because we have adopted the technique of putting a number of amplificatory comments in the form of footnotes so that they will be available to the interested reader, yet not interrupt the flow of the arguments in the main text. It is our hope that this technique will prove a successful compromise at being informative without being distracting.

FUNDAMENTALS

1. Tools and Methods

a. Experimental Tools

In one form or another, all the techniques described here involve measurement of the frequency spectrum of the cavity. All the measurements described here are transmission (S_{21}) responses: A signal is injected by an antenna at one end of the cavity and detected by an antenna at the other. Since the only modes which can influence the beam are those with longitudinal electric fields (TM modes), our antennas take the form of electric probes which are oriented parallel to the longitudinal axis of the cavity at the inner radius of the beam tube aperture (see Fig. 2).

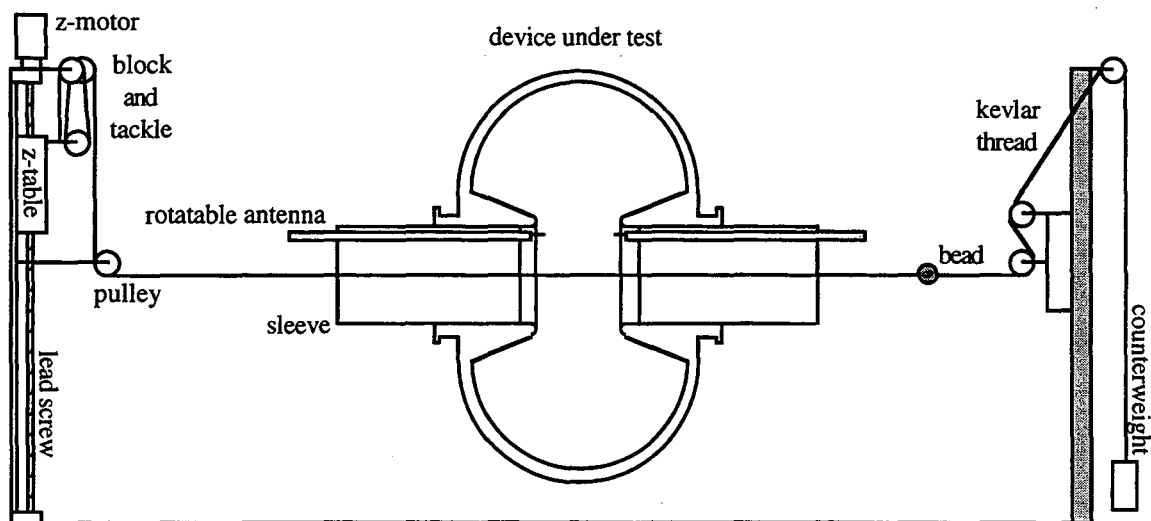

Fig. 2. The prototype PEP-II RF cavity mounted in the bead puller (see text); the "bead" used in the work described here is actually in the shape of a needle. The S_{21} measurements are made by connecting the ports of a network analyzer to the two rotatable antennas.

Each antenna takes the form of a section of copper-walled .141" semi-rigid 50 ohm cable, with the center conductor exposed at one end, which is attached to a rolled sheet metal sleeve that fits snugly inside the beam tube at either end of the cavity. This permits longitudinal positioning of the probes so that an adequately large signal can be obtained with minimal

perturbation of the cavity field geometry. It also permits *angular* positioning the probes, relative both to the cavity and *to each other*.¹

In addition to the measurement of the S_{21} spectrum itself, we also make measurements of the *shift* of the spectrum resulting from the introduction of a perturbing object, a technique known generically as a "bead pull" [2]. The method makes use of the fact that the introduction of a perturbing object produces a frequency shift which is proportional to the square of the local electric and magnetic fields² at the location of the object (the "bead"), and also depends on the electric/magnetic properties of the bead material and a form factor which depends on the bead's shape [3]. For a bead in the shape of a metal needle, its form factors for fields perpendicular to the needle are much smaller than those for the parallel fields.

For TM fields, a needle probe oriented parallel to the longitudinal axis responds almost exclusively to the longitudinal electric field. Measuring the frequency shift as a function of the axial position of the needle permits one to map the axial distribution of the longitudinal electric field, which in turn permits one to calculate longitudinal beam impedance (see Ref. 2). A series of longitudinal bead pulls with the bead offset at different transverse positions (a "transverse scan") permits calculation of transverse impedance. If the x - and y - transverse positions are independently adjustable by computer-controlled stepping motors, it is possible to move the bead along a circular path in the transverse plane and thereby measure the angular variation of the longitudinal field at one or more axial locations ("angular scans").

b. Analytical Tools

Probably the most essential of these is a means for generating a catalogue of the resonant frequencies of the modes of an idealized version of the cavity. The word "idealized" can mean anything from neglecting the effect of beam port apertures, tuners, or coupling structures to approximating the cavity by a simple pillbox. The reason for resorting to such an idealized catalog is that while a 3-D numerical field solver such as MAFIA can predict frequencies exactly, it does not provide ready identification of the character of the modes, such as their multipolarity; moreover, such a solver is generally limited by computer memory size as to the accuracy and/or the number of the modes it can calculate. On the other hand, a simple model such a pillbox,

¹The degree of flexibility in angular positioning should at least permit orientation of the probes at angles of 0°, 45°, and 90° relative both to each other and to any symmetry axes of the cavity; this point is discussed more fully below.

²Magnetic fields at the location of a conducting bead produce a positive frequency shift; electric fields, a negative one.

although it permits construction of such a catalog without resort to a computer, is generally too crude.

The best tool for constructing a catalog of modes for a quasi-axi-symmetric structure usually proves to be a 2-D simulation code such as URMEL [4], in which the cavity can be represented as a figure of revolution, which specifically identifies the eigenmodes by their multipolarity. A code such as this permits a fairly good representation for determining the eigenfrequencies of cavities with non-cylindrical shapes (the illustration in Fig. 2 is actually a reasonable approximation of the actual B-Factory cavity shape), and in fact enables one to take into account the not insignificant effect of the beam ports. Indeed, the various modes and resonant frequencies for the symmetric configuration in Fig. 1 (dashed curve) are in remarkably good agreement with the URMEL predictions, and in that figure they are labeled in correspondence with those predictions.

We discuss briefly two other analytical tools which prove useful in mode identification. The first of these is a computer code which calculates beam impedance from frequency-shift data. Plotting the impedance as a function of transverse position in a transverse scan, as described in detail in Sect. 6a below, provides a quantitative confirmation of a mode's multipolarity. A second useful tool is a curve-fitting routine which is capable of fitting at least three (Lorentzian) peaks simultaneously. Such a code provides confirmation of the relative longitudinal parities of adjacent modes (see Sects. 2 and 5 below), although its primary use lies in the determination of beam impedance, a topic not addressed explicitly in this report: Particularly in the case of the damped cavity, such a code is necessary to extract the Q-values of strongly overlapping peaks.

2. Geometric Considerations; Symmetries

All of the techniques described in this note involve utilizing geometric considerations or symmetry arguments in conjunction with the above measurement methods. It is therefore useful to review some of these considerations before discussing specific techniques.

a) Longitudinal Parity For a cavity which exhibits reflection symmetry about the longitudinal midplane, the modes can be classified according to whether the longitudinal electric field is symmetric or anti-symmetric about the symmetry plane. In URMEL parlance, such modes are classified as E and M modes respectively, referring to whether the boundary conditions at the

longitudinal midplane are "electric" (the electric field is normal to the midplane) or "magnetic" (the magnetic field is normal to the midplane).³

This difference in symmetry can be seen in the examples in Fig. 3, which illustrates the electric and magnetic fields of the fundamental (TM₀₁₀) as well several higher-order modes of a pillbox cavity. We use normal RF convention to describe longitudinal symmetry, which is to say that because for E modes $E_z(-z) = E_z(z)$, the E fields of these modes are *even*, and those of the M modes, *odd*.⁴ Concentrating on the TM modes, we see that the longitudinal parity of the TM₀₁₀ and TM₀₂₀ modes is even; that of the TM₀₁₁, odd. In general, for any TM_{mnq} mode, the parity is even for even q ; odd, for odd q .

b) Transverse Parity For a cavity with rotational symmetry or with a plane of transverse reflection symmetry, modes can be classified according to their transverse reflection symmetry.⁵ In the former case, the reflection symmetry can be defined relative of any pair of mutually orthogonal axes; in the latter, relative to a pair of axes which are parallel and perpendicular to the symmetry plane.

Modes other than monopoles (azimuthally invariant modes) occur in pairs. For a cavity with (a possibly broken) rotational symmetry, these are in pairs of $2n$ poles; for a rectangular cavity, in modes obtained by the interchange of the (unequal) vertical and horizontal indices. In the former case, for odd n one member of the pair will exhibit odd parity with respect to reflection in the symmetry plane⁶ and even parity with respect to the orthogonal plane, and the other member the opposite parities. For example, in the TM₁₁₀ dipole, shown in Fig. 3, the E-field exhibits odd parity with respect to reflection about the x - z plane, and even parity with respect to the y - z plane. There is a second TM₁₁₀ dipole (not shown), identical except for being rotated by 90° about the z -axis, whose reflection symmetries are the opposite.

For even n , the one member will exhibit both parities to be even, and the other, both odd, e.g., the normal and skew quadrupole pair. The normal component, as exemplified by the TM₂₁₀ quadrupole illustrated in Fig. 3, exhibits the even-even symmetry; the skew component,

³To further explain the URMEL notation in Fig. 1, the number preceding the E/M designation indicates the predicted multipolarity (0 for monopoles, 1 for dipoles, etc.), and the one following it is simply the means of ordering the modes of a given type, e.g., the 0M3 is the third E-type monopole.

⁴By the standard convention of reflection symmetry, the longitudinal E-fields of the E modes would have *odd* parity; since upon reflection about the symmetry plane at the cavity center ($z = 0$) they would appear *oppositely* directed. As we shall repeatedly note, what is important is not the *absolute* parity of a given mode, but its parity *relative* to that of some other mode. Hence the choice of convention is arbitrary; it must, however, be applied consistently.

⁵For transverse parity, in contrast to longitudinal parity, the "standard" reflection convention and the $E_z(-x) : E_z(x)$ convention yield the same definition of parity.

⁶For unbroken symmetry, this plane may be chosen arbitrarily.

(not shown) resulting from a rotation of that mode by 45° about the z -axis, exhibits odd-odd.⁷

Monopole modes:

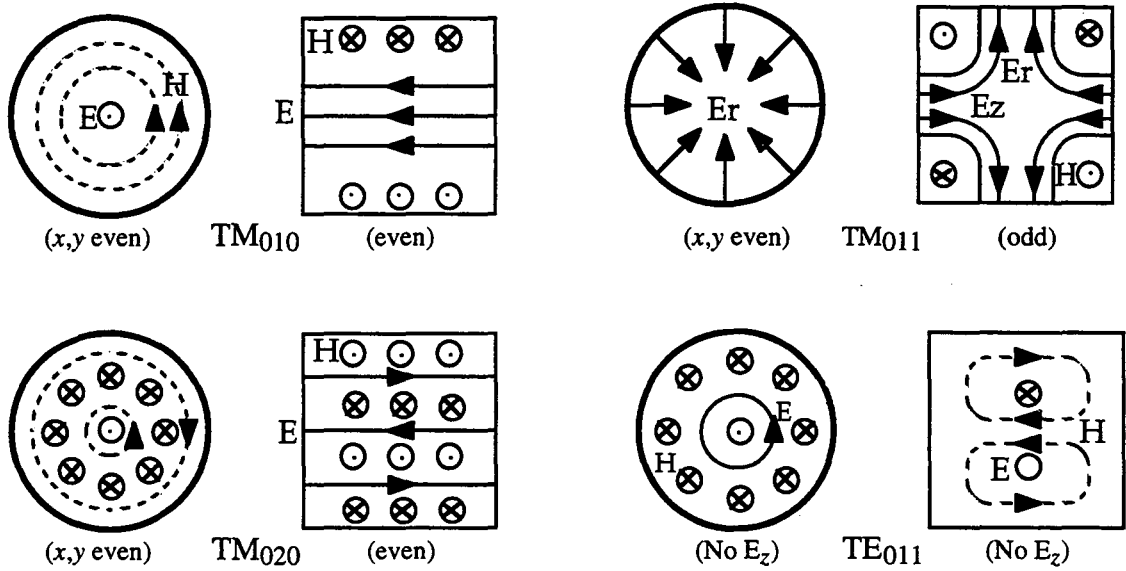

Dipole modes:

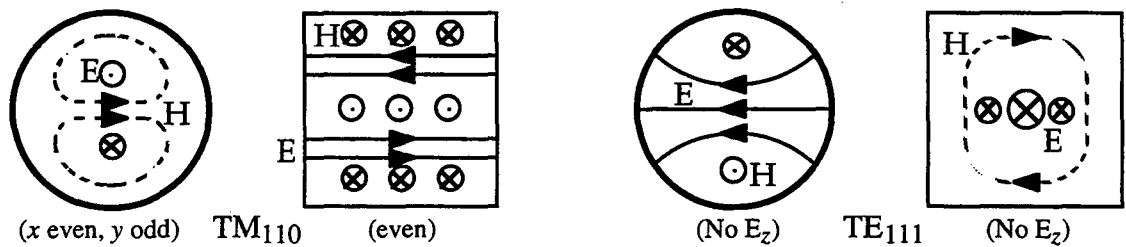

Higher-order modes

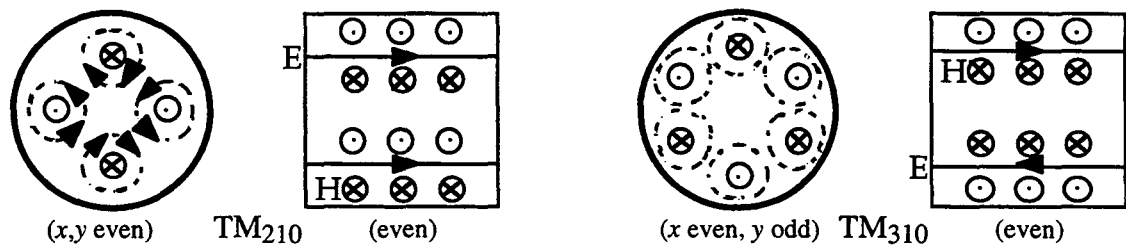

Fig. 3. Electric and magnetic fields for various modes of a pillbox cavity. The left-hand member of each figure pair shows the field-patterns in the x - y plane; the right-hand, the y - z plane. The notations below the figures indicate the symmetries of the *longitudinal* E-field: Those below the y - z views show the longitudinal symmetry; those below the x - y , the transverse.

⁷Note that the *overall* transverse parity of a multipole (the product of the vertical and horizontal parities) is the *same for both members of the pair* and is odd or even as n is odd or even. An analogous result holds for the rectangular-mode pair, in this case the overall parity being the same as that of the sum of the vertical and horizontal indices.

3. Mode Mixing and Mode Anchoring

Attempts at mode identification applying the above principles in an overly simplistic way can be confounded by the phenomenon of mode mixing [5]. As pointed out in Ref. 5, the presence of perturbing objects can couple not only modes which (owing to symmetry) were degenerate in the absence of the perturbation, but even modes which were not; the condition for the latter to occur is that the integral over the perturbing volume of the product of the fields of the two modes be non-vanishing⁸ and that the frequency associated with this product term be significant compared with the frequency difference of the unperturbed modes.

The most obvious adverse consequence of mode mixing is simply that one fails to account for it and assumes that the modes of the unperturbed, symmetric cavity retain their identities in the presence of perturbations such as dampers, couplers, etc., and overlooks the actual "fragmentation" of modes that occurs. For example, if a nearby monopole and dipole mix, in assessing their effect on the beam, one must take into account the monopole impedance of *both* the resulting modes, *as well as* the dipole impedance, again of *both* modes.

A more subtle problem occurs when one attempts to identify the modes of the unperturbed cavity, a preliminary step in mode identification which is done by measuring the spectrum with the insertions removed and the ports covered over. In that highly symmetric configuration, the measuring probes themselves become the symmetry-defining objects, and so any re-positioning the probes in attempting to identify various modes actually changes the nature of the modes being identified. Hence if one wishes to use such a probe-positioning technique, it is generally necessary to deliberately include some symmetry-breaking perturbation in order to "anchor" the modes so that their orientation is unaffected by the angular position of the probes.

⁸For perturbations of a given reflection or rotational symmetry, a sufficient condition for its ability to mix two modes is that both modes have the same symmetry; a sufficient condition for it being *unable* to mix them is that the two modes have *opposite* symmetries. For example, a perturbing volume which has up-down symmetry can mix a monopole and a (nearby) quadrupole, but cannot cause the mixing of either with a vertical dipole.

MEASUREMENT AND INTERPRETIVE TECHNIQUES

4. Probe Positioning

Let us start by considering a cavity in which the rotational symmetry has been broken by a perturbation which lies on, and, to make things simple, is symmetric about the vertical (y) axis. Such a perturbation will remove the degeneracy between the components of all multipole pairs and will also serve to anchor them so that their orientation is unaffected by that of the probes. For definiteness let us consider a particular pair of dipole modes; similar arguments will apply, *mutatis mutandis*, to all multipole pairs.

The above perturbation will split the (now-non-degenerate) dipole pair into a component whose longitudinal electric field has its maximum amplitudes on the y -axis (vertical) and goes to zero on the x -axis (horizontal), and a second component whose maxima are on the x -axis and whose zeroes are on the y -axis; we will denote these as the y - and x -components of the dipole respectively. To first order, the perturbation will affect only the frequency of the y component; whether it raises or lowers its frequency will depend on whether the perturbation is in the form of an aperture or an insertion.

If we now position probes 1 and 2 on the x -axis (defined as 0°), they will be capable of exciting only the x -component of the dipole. Likewise, positioning the probes on the y -axis (90°) will excite only the y -component. Positioning both probes at 45° will result in equal excitation of both components. Hence to record a single cavity spectrum in which both dipole components are visible, for optimum definition of both components, the probes should be in the 45° position; in particular, they should *not* be near either 0° or 90° .⁹

Probe positioning therefore provides a quick "handle" on mode identification. While the "ultimate" test of identity is the angular distribution, a quick verification of the posited dipole character of a pair of modes is their successive (out-of-phase) appearance and disappearance as the probe angles are changed in tandem.¹⁰ Note that if we position probe 1 at 0° and probe 2 at

⁹The angles of course depend on the multipole being studied; for the quadrupoles, for example, both 0° and 90° will excite the *same* component of the quadrupole (the "normal" one), and 45° orientation will suppress that component, exciting only the skew quadrupole. The spectrum of the "actual" cavity in Fig. 1 was taken with the probes at 15° , so that the two components of both the dipoles and the quadrupoles are visible.

¹⁰Note that absent the anchoring perturbation, this method would yield only one component of the dipole, namely the one whose maximum lies at the probe angle, since that mode, being unconstrained by any perturbation other than that produced by the probes themselves, will simply rotate along with the probes.

90° (or vice versa), *both* components of the dipole will be suppressed: in the former instance probe 1 will excite only the *x*-component of the dipole, whereas probe 2 is capable of responding only to the *y*-component; in the latter, the situation is reversed. The above considerations are illustrated in Fig. 4, which shows spectra obtained from the prototype PEP-II RF cavity in the frequency region corresponding to the 1M3 dipole. The four spectra were taken with probe angular positions $(\theta_1, \theta_2) = (45^\circ, 45^\circ), (0^\circ, 0^\circ), (90^\circ, 90^\circ),$ and $(0^\circ, 90^\circ)$. In the first configuration, both dipole components are strongly excited. In the $(90^\circ, 90^\circ)$ orientation the horizontal (upper)¹¹ component is virtually completely suppressed; in the $(0^\circ, 0^\circ)$, the vertical component is suppressed by over 10 dB relative to the horizontal. In the $(0^\circ, 90^\circ)$ configuration, *both* components are suppressed by more than an order of magnitude, relative to their values at their respective angles of maximum excitation.

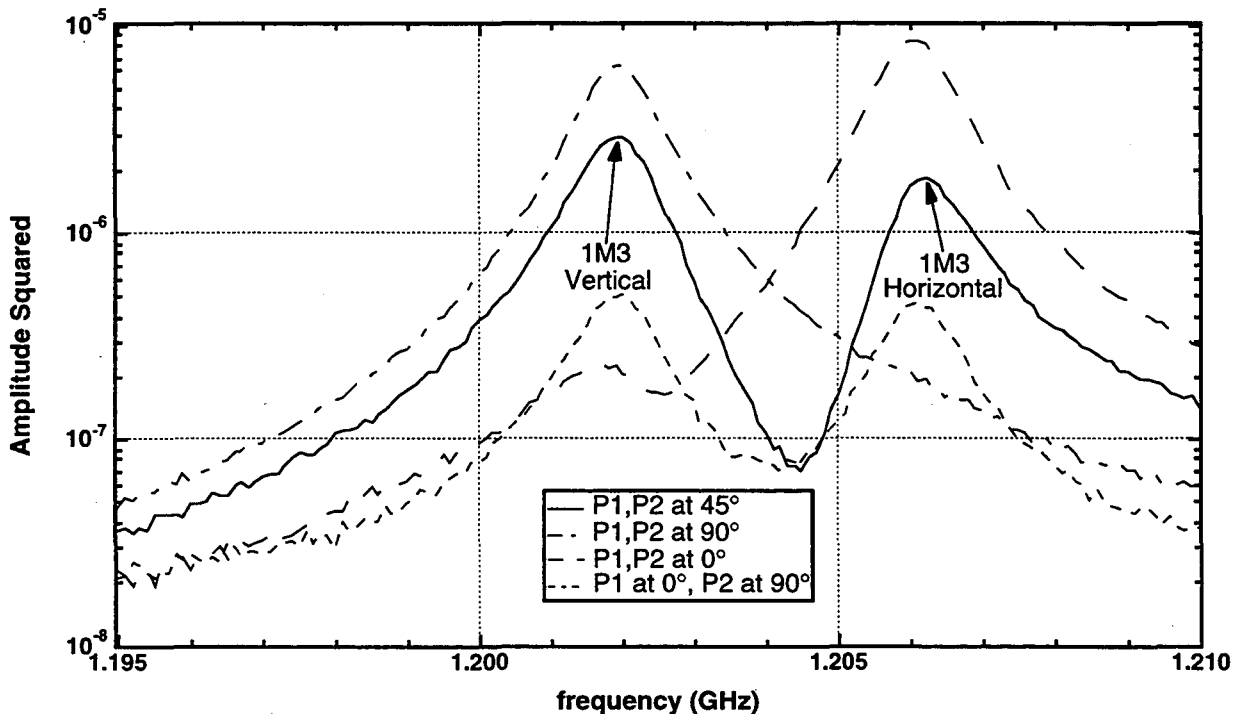

Fig. 4. Effect of probe angle on relative amplitudes of members of the 1M3 dipole pair.

While the above "tricks" are useful in mode identification they can also be useful when doing bead pulls. The bead-pull technique requires measuring the frequency shift of a particular mode (or equivalently, its phase shift at a particular frequency) to determine the field associated

¹¹Because in this case the anchoring perturbation — the coupling aperture — takes the form of a horizontal aperture in the region where the horizontal component's electric field is maximum, the frequency of this component is shifted upward.

with that mode. Consider what happens in the case of overlapping resonances,¹² which we will designate as modes 1 and 2. As the bead enters a region where mode 2 has a high field, its resonant frequency will shift causing an apparent shift in the resonant frequency of mode 1, or equivalently of the phase at that frequency, *which has nothing to do with the field of mode 1 at the bead location*. If it turns out that one of these peaks is a monopole and the other a dipole, the spurious effect can be minimized by, on the one hand, positioning the probes so as to minimize the dipole response when bead-pulling the monopole, and on the other, positioning them to maximize the dipole response when measuring the dipole. (The monopole response should be independent of probe position, although some small variation may result as a result of the symmetry-breaking perturbation.)

5. Parity Signature

A given mode of an antenna-driven resonant cavity can be modeled as a current-driven parallel RLC circuit. As such its voltage response varies from inductive at low frequencies to capacitive at high frequencies, and so the phase of the S_{21} response drops by a total of 180° as one sweeps the driving frequency across the resonance.

Let us consider two adjacent, but reasonably well separated modes which have the same longitudinal parity. At frequencies lying between the two resonances, the response of the lower resonance's phase will have changed from its low-frequency value by an amount $-\pi/2 > \Delta\phi_1 > -\pi$, whereas that of the upper resonance will have changed by $0 > \Delta\phi_2 > -\pi/2$. For well separated resonances, over much of this region $\Delta\phi_1 \approx -\pi$ and $\Delta\phi_2 \approx 0$. Hence at the frequency at which the (rising) amplitude of the upper mode and the (falling) amplitude of the lower are equal, the combined responses will add nearly to zero, accompanied by a sudden jump in the phase of S_{21} of $(+)\pi$. The effect is illustrated in Fig. 5 for the case of the 2E3, 0E4, and 1E5 modes. All three of these, being E-modes, are of like longitudinal parity, and the regions between successive peaks exhibit the expected sharp notch and abrupt phase jump.

Let us contrast that with the case where the modes have *opposite* longitudinal parity. In this case there is an additional phase shift of π in the relative responses, due to the fact that the field of one mode at probe 2 is reversed relative to the field of the other mode. (Note that it does not matter which mode has which parity, only that the parities be opposite). Hence the above-resonance responses of the lower mode and the below-resonance response of the upper are

¹²In this discussion we ignore any considerations of mode *mixing*; particularly in the case of low-Q modes, it is possible for modes to have significant overlap without the occurrence mode mixing.

always *in phase*, so that there is neither a subtraction of the amplitudes in the combined response, nor a discontinuity in the phase at any intermediate frequency.

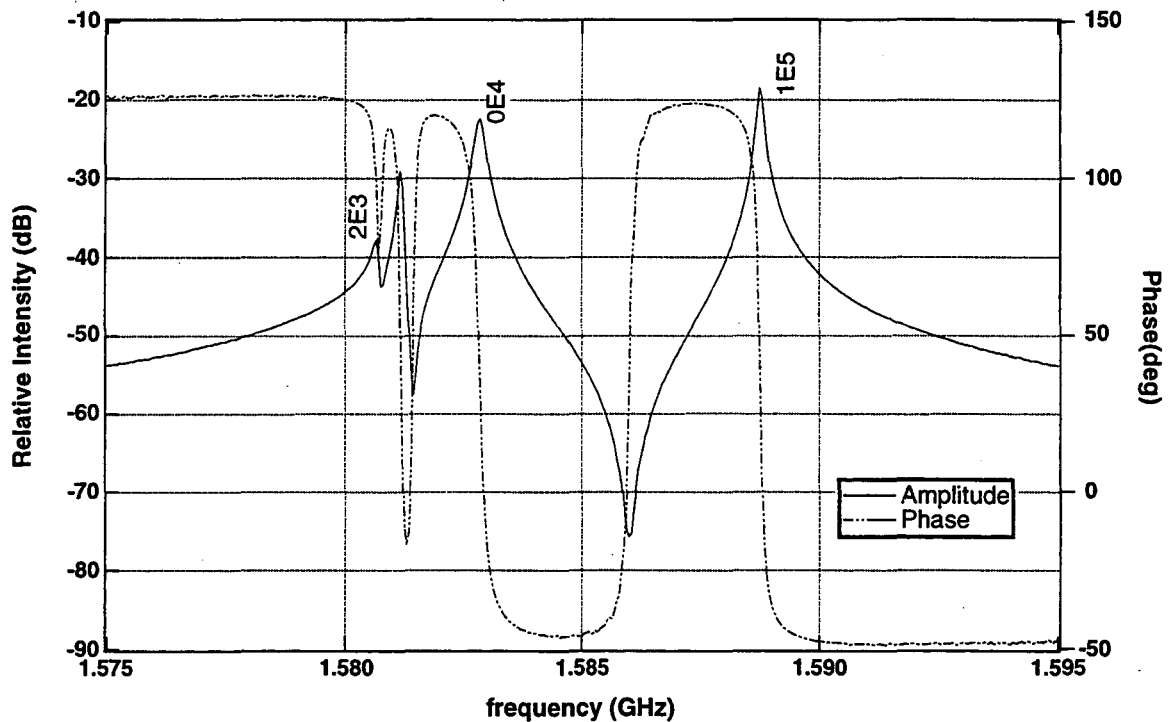

Fig. 5. Characteristic notches between adjacent peaks of like parity, accompanied by the abrupt phase jumps of $\approx\pi$. Note that the more well-separated the peaks are (relative to their respective Q-values) the more closely their interfering amplitudes approach a relative phase of π , and hence the more nearly complete the cancellation (the deeper the notch).

The situation is shown in Fig. 6 for the case of the 0M1 (TM₀₁₁) and 1E1 (TM₁₁₀) modes. The minimum between the peaks exhibits no notch, as the phase makes a smooth transition. This can be contrasted with the region between the two components of the 1E1 dipole, which is characterized by the sharper notch expected between two peaks of like parity.

At frequencies above or below a pair of resonances the responses of the two modes approach π *out of phase*, and at a point in the neighborhood of the weaker resonance, where its amplitude falls back below that of the stronger (but more distant) one, there will be a cancellation in the combined response and a notch will appear. When a weak peak sits on the shoulder of a strong one, this parity signature is particularly pronounced (see Fig. 7).

These parity signatures are generally unambiguous. In the few cases where they are not, possible doubts about parity assignments are invariably resolved by the results of the curve-fitting routine described in Sect. 1b.

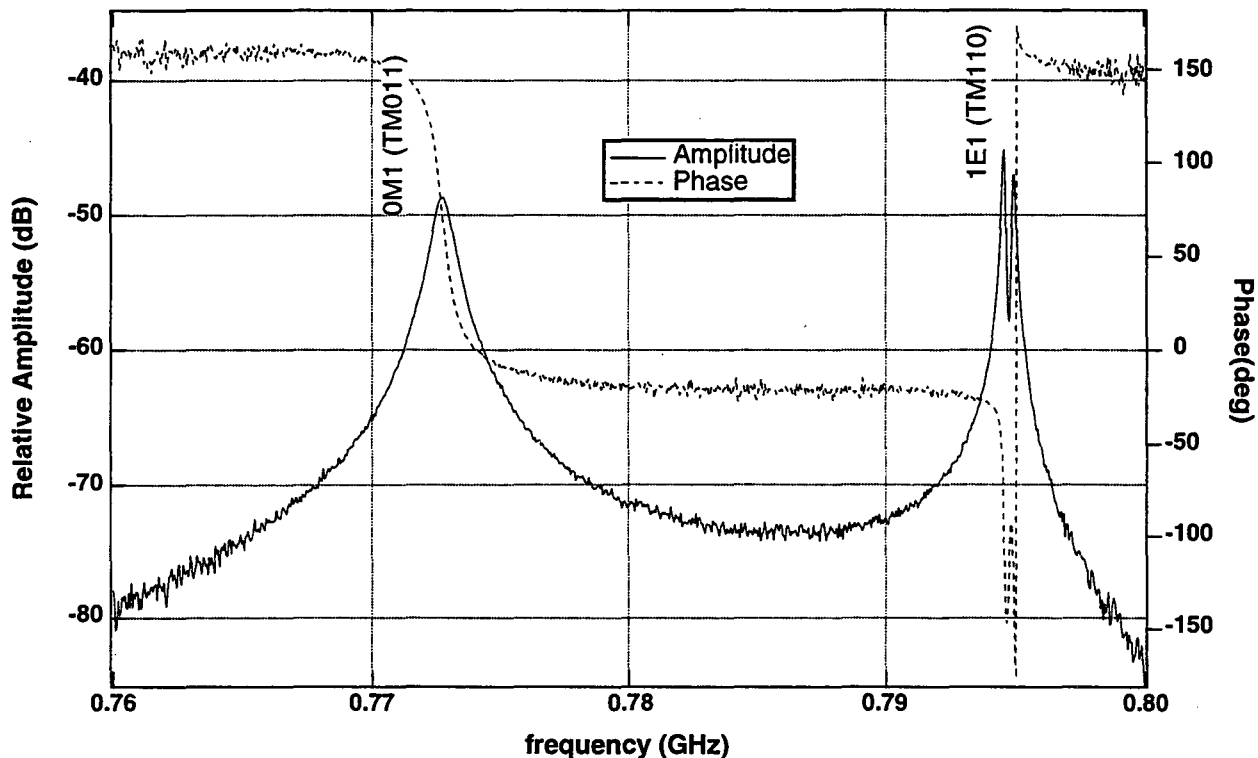

Fig. 6. Characteristic smooth transition between adjacent peaks of opposite parity. Note that, in contrast to the like-parity case, the phase of the response varies smoothly over the inter-peak region, and consequently no cancellation of amplitudes occurs.

While azimuthal reflection parity is not particularly useful for mode identification in the present cavity/probe geometry, it can be in other cases, and the present cavity can be used to illustrate it. As noted earlier, the x dipole has odd parity with respect to reflection about the x axis and even parity with respect to reflection about the y -axis, and conversely for the y dipole. With a symmetry-breaking perturbation on the y axis anchoring the orientation of the dipole pair, and probe angles set at 45° , both peaks appear in the spectrum and will exhibit the notch characteristic of like parity. If we now move probe 2 to -45° , both peaks will still be present, but the response of the y dipole will have shifted by π and the notch will disappear. Had we moved probe 2 to 135° , it would have been the x -dipole's phase which shifted by π , but the result would have been the same, since it is only the *relative* parity which matters.

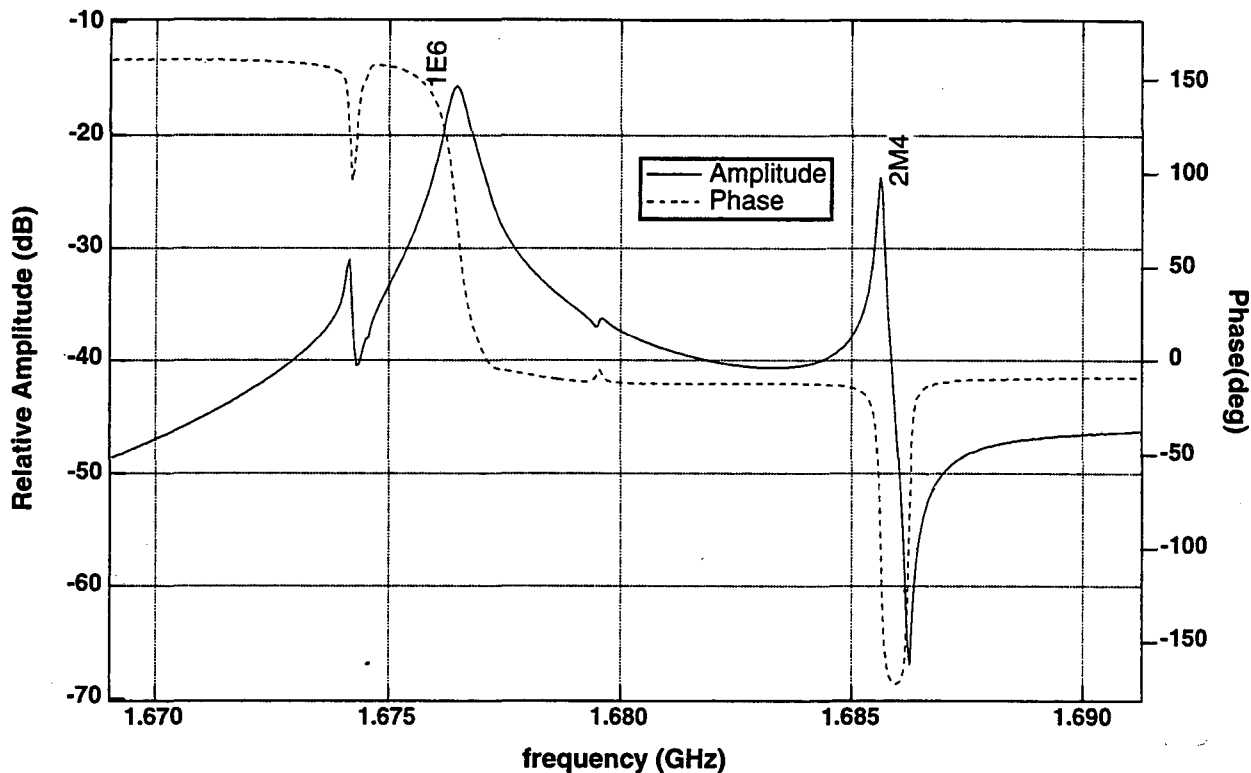

Fig. 7. Weak modes on the shoulder of a strong mode. The weak peaks on either side of the 1E6 dipole are evidently both E modes, as evidence by the notches between them and the 1E6. The fact that the uppermost (2M4) peak is an M mode is responsible for the absence of a notch between it and the weak peak to the right of the 1E6 peak.

6. Bead Pulls

Although longitudinal scans can be used to confirm a mode's identification,¹³ i.e. by comparing the predicted and measured field distributions, transverse and azimuthal scans are at least equally useful in mode identification, in particular in determining the multipolarity of the mode.

(a) Transverse Scans - As described earlier, a transverse scan is actually a series of longitudinal scans done with the bead offset by different transverse positions. In the presence of an anchoring perturbation, the probes should be aligned along the perturbation-defined axis (in the situation we have been discussing, the y -axis), and the scan done in the same direction. For odd- n multipoles, the orthogonal component of the multipole can be scanned with the probes aligned in

¹³In addition to assisting in mode identification, such scans enable one to assess the strength of a mode's interaction with the beam, i.e., measure its beam impedance; in fact, this was the purpose for which the technique was originally developed.

the orthogonal (x) direction and the scan done in that direction. For even- n multipoles there is no universal angle which will exclusively (and maximally) excite the orthogonal component for arbitrary n .¹⁴

Determining multipolarity from a transverse scan makes use of the fact that at small radii the strength of the longitudinal field of a $2n$ -pole varies as r^n and so its longitudinal shunt impedance $R_{\parallel}T^2$ which is proportional to E_z^2 , varies as r^{2n} . Hence if we do a transverse scan and plot $R_{\parallel}T^2$ vs various powers of r , we can determine n by noting for which value of n the plot is linear. For example, for dipole modes $R_{\parallel}T^2$ will be proportional to r^2 ; for quadrupoles, r^4 , etc.

(b) Angular Scans - While, because of its quantitative nature, the transverse scan is potentially the most definitive identifier of a multipole's character, it may prove of limited use where there is a background from underlying or overlapping resonances, or where mode mixing [5] occurs. In these situations, the angular scan may be the most effective means of unraveling the situation.

The angular scan is actually a series of measurements. The first of these is a longitudinal scan with the bead offset from the transverse center by a distance equal to the radial distance at which the angular scans will be done; since multipole field strength increases with radius, this distance will generally be the maximum radius permitted by the beam-tube aperture, in our case 4 cm. The displacement for the initial longitudinal scan will generally be at the same azimuth at which the probes are positioned, that azimuth being determined experimentally as the one which maximizes the S_{21} response for the mode being investigated. Typically such a longitudinal scan will show two or more z values where the field strength exhibits local maxima. One then successively takes angular scans at these z values, and possibly at the z values corresponding to the intervening field minima as well.

Because the frequency shift is proportional to the square of the field, the angular scan will have an angular periodicity double that of the multipole being scanned. Hence a scan done at 15° intervals will give 6 points per oscillation for modes up to quadrupole, and assuming a nearly vertical symmetry axis, will include the maxima of both the normal and skew quadrupole fields.

While the angular scan's ability to confirm mode identification based on either probe-position or transverse-scan data is often useful, probably its most powerful attribute is its ability

¹⁴In our experiments, quadrupole and high polarity modes were not deemed of sufficient importance to warrant the additional coding which would allowed a transverse scan in any direction other than x or y .

to help identify the character of fields which result from superposition of more than one multipole either as a result of mode overlap or mode mixing. An example of this is provided in Figs. 8a and 8b for the case of the 1E6 dipole with the cavity dampers present, causing overlap of adjacent modes.

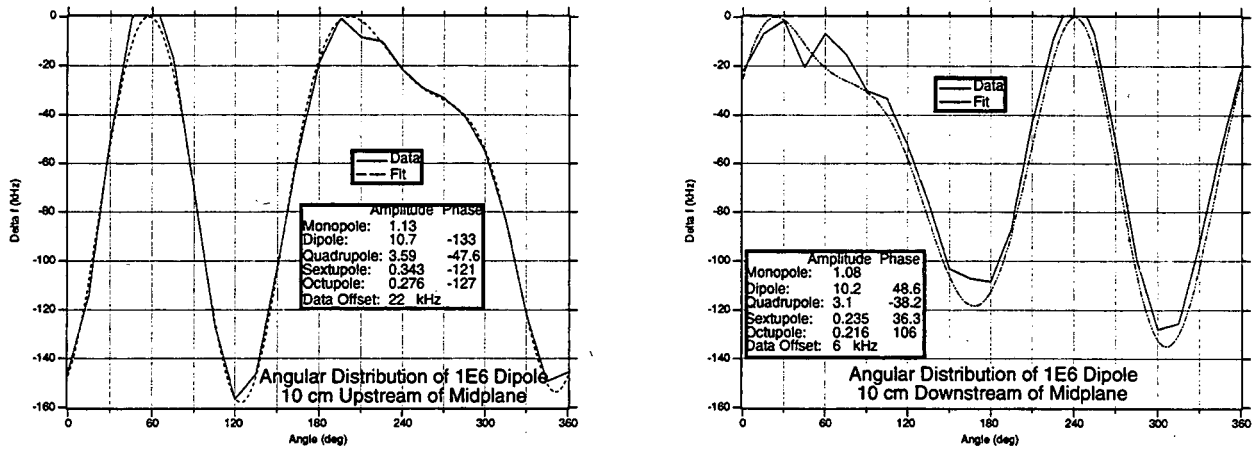

Fig. 8. Angular scans of the 1E6 dipole in the presence of damping, causing overlap of that mode with the 2M4 quadrupole and 0M3 monopole. The phases of the relative amplitudes have been "normalized" relative to that of the monopole (see text).

The angular scans are made 10 cm upstream and downstream, respectively, of the cavity center, which are the locations of the maxima of E_z for this mode. As seen from Fig. 1, the 1E6 sits alongside the 2M4 quadrupole and the 0M3 monopole, and with the broadening of the linewidths in the presence of damping, the lines of all three overlap, so that the distribution does not look like that of a pure dipole.

With the aid of the computer code IGOR, we have fitted the two distributions using multipoles as high as octupole. As may be seen from the figures, the respective multipole amplitudes are roughly the same for both distributions, with the dipole dominant, non-negligible contributions coming from the monopole and quadrupole, and virtually none from sextupole and octupole. An interesting feature is the phase reversal of roughly 180° in the dipole between the two distributions. At first blush this might seem contrary to expectation, since the dipole is an E-mode, i.e. of even longitudinal parity. However, because we have "normalized" the phase of all multipoles to that of the monopole, which is an M-mode (odd parity) and hence *does* reverse phase, it is the dipole which shows the apparent phase reversal; the quadrupole, also being an M-mode, shows none.

SUMMARY

The techniques described in this paper are both simple and powerful, enabling one to unravel a complex spectrum of higher order modes using merely a few "basic" principles. The only restriction on the applicability of these methods is that the cavity possesses an underlying symmetry (possibly broken by the addition of couplers, ports, etc.) which provides a basis for classifying its higher order modes and identifying their fundamental character. The original symmetry need not be rotational, as has been evidenced by the fact that many of these techniques have recently been applied successfully to the analysis of the HOM spectrum of a (slightly-off-square) rectangular cavity [6]; clearly, for such a cavity an angular scan would be of limited utility. In fact it is the universality of the approach described here that we feel makes it so useful.

ACKNOWLEDGMENTS

Many of the data illustrated in this report were taken with the able assistance of Michael Irwin. This work was supported by the Director, Office of Energy Research, Office of High Energy Physics and Nuclear Physics Division of the U.S. Department of Energy under contract No. DE-AC03-76SF00098.

REFERENCES

1. "Updated Impedance Estimate of the PEP-II RF Cavity", R.A. Rimmer et.al., Proc EPAC 96, Sitges, Barcelona, 10-14 June, 1996 (PEP-II AP Note 96.06, LBNL 38929, SLAC PUB 7211), and references therein.
2. D. A. Goldberg and R. A. Rimmer, "Automated Bead-Positioning System for Measuring Impedances RF Cavity Modes," in *Proc. 1991 IEEE Particle Accelerator Conf.*, pp. 871-873, and references therein.
3. J. C. Slater, *Microwave Electronics*, Van Nostrand, Princeton, N. J. (1950), p. 81.
4. T. Weiland, "On the Computation of Resonant Modes in Cylindrically Symmetric Structures, *Nucl. Inst. Meth.* 216 (1983), p. 329.
5. D. A. Goldberg, "Understanding the Mixing of Higher-Order Modes of Multiply Resonant Systems, CBP Tech Note-119.
6. I. Bacchus and D.A. Goldberg, "Higher-Order-Mode Spectrum of a Prototype Schottky Cavity," LBNL CBP Tech Note 109 (unpublished).

**ERNEST ORLANDO LAWRENCE BERKELEY NATIONAL LABORATORY
ONE CYCLOTRON ROAD | BERKELEY, CALIFORNIA 94720**