

UCLA

UCLA Previously Published Works

Title

Correction to: Characterization of bone morphology in CCN5/WISP2 knockout mice

Permalink

<https://escholarship.org/uc/item/4fb3v1bh>

Journal

Journal of Cell Communication and Signaling, 12(1)

ISSN

1873-9601

Authors

Jiang, Jie

Zhao, Gexin

Lyons, Karen M

Publication Date

2018-03-01

DOI

10.1007/s12079-018-0463-5

Peer reviewed

Published Erratum J Cell Commun Signal

. 2018 Mar;12(1):271. doi: 10.1007/s12079-018-0463-5.

Correction to: Characterization of bone morphology in CCN5/WISP2 knockout mice

Jie Jiang 1, Gexin Zhao 2 3, Karen M Lyons 4 5

Affiliations expand

PMID: 29455304 PMCID: PMC5842214 DOI: 10.1007/s12079-018-0463-5

Free PMC article

Abstract

In the original publication's title CCN5/WISP5 should have been CCN5/WISP2.



Characterization of bone morphology in CCN5/WISP5 knockout mice

Jie Jiang¹ · Gexin Zhao^{2,3} · Karen M. Lyons^{3,4}

Received: 15 January 2018 / Accepted: 25 January 2018 / Published online: 2 February 2018
© The International CCN Society 2018

Abstract

CCN5/WISP2 is part of the CCN family of matricellular proteins, but is distinct in that it lacks the C-terminal (CT) domain. Although CCN5 has been shown to impact cell proliferation and differentiation *in vitro*, its role *in vivo* is unclear. We therefore generated mice using ES cells developed by the Knockout Mouse Project (KOMP) in which exons 2–5, which encode the all of the conserved protein coding regions, are replaced by a lacZ cassette. *Ccn5^{LacZ/LacZ}* mice were viable and apparently normal. Based on previous studies showing that CCN5 impacts osteoblast proliferation and differentiation, we performed an analysis of adult bone phenotype. LacZ expression was examined in adult bone, and was found to be strong within the periosteum, but not in trabecular bone or bone marrow. Micro-CT analysis revealed no apparent changes in bone mineral density (BMD) or bone tissue volume (BV/TV) in *Ccn5^{LacZ/LacZ}* mice. These studies indicate that CCN5 is not required for normal bone formation, but they do not rule out a role in mechanotransduction or repair processes. The availability of *Ccn5^{LacZ}* mice enables studies of CCN5 expression and function in multiple tissues.

Keywords CCN · Bone

Introduction

CCN5/WISP2 is part of the CCN family of matricellular proteins, which is named for its founding members: CCN1/CYR1, CCN2/CTGF, CCN3/NOV, CCN4/WISP1, CCN5/WISP3, and CCN6/WISP3. Members of the CCN family of matricellular proteins share similar modular protein structures, containing an N-terminal secretory signal peptide, an insulin-like growth factor binding protein (IGFBP), a von Willebrand factor type C repeat (vWC), a thrombospondin type 1 repeat

(TSR), and a cysteine knot motif within the C-terminal (CT). CCN5 is unique among members of this family by lacking the CT domain (Fig. 1). The biological role of CCN5 is unclear, but as a matricellular protein, CCN5 resides in the extracellular matrix, and likely serves regulatory rather than structural roles. Exogenous CCN5 has been shown to regulate an array of processes, including proliferation, migration, angiogenesis, tumorigenesis, differentiation, adhesion and ECM synthesis. Whether CCN5 is required *in vivo* is unknown.

CCN5 was originally cloned in the 1990s by several groups. The first publication by Delmolino et al. (Delmolino and Castellot 1997) found that CCN5 was up-regulated in human vascular smooth muscle cells after treatment with heparin (Delmolino and Castellot 1997). This group named it Heparin-Induced CCN-like Protein (HICP). About the same time, another group found that *Ccn5* was upregulated in the mouse mammary epithelial cell line C57MG after transformation by Wnt-1 (Pennica et al. 1998). This group named it Wnt-Inducible Secreted Protein-2 (WISP-2). Several other names were assigned to *Ccn5* by other groups around this time.

All six members of the CCN family are expressed in bone (Chen et al. 2014, Parisi et al. 2006). To date, functions in bone have been described for CCN1/Cyr61, CCN2/Ctgf, CCN3/Nov, and CCN4/Wisp1. Conditional knockout of *Ccn1/Cyr61* using Osteocalcin-Cre led to a low bone mass

Jie Jiang and Gexin Zhao are co first authors

✉ Karen M. Lyons
klyons@mednet.ucla.edu

¹ Department of Pediatrics, Rush University Medical Center, Chicago, IL, USA

² Department of Pathology and Lab Medicine, David Geffen School of Medicine, University of California, Los Angeles, Los Angeles, CA, USA

³ Department of Orthopaedic Surgery, David Geffen School of Medicine, University of California, Los Angeles, 615 Charles E. Young Dr. South, Room 510, Los Angeles, CA 90095, USA

⁴ Department of Molecular, Cell and Developmental Biology, University of California, Los Angeles, Los Angeles, CA, USA

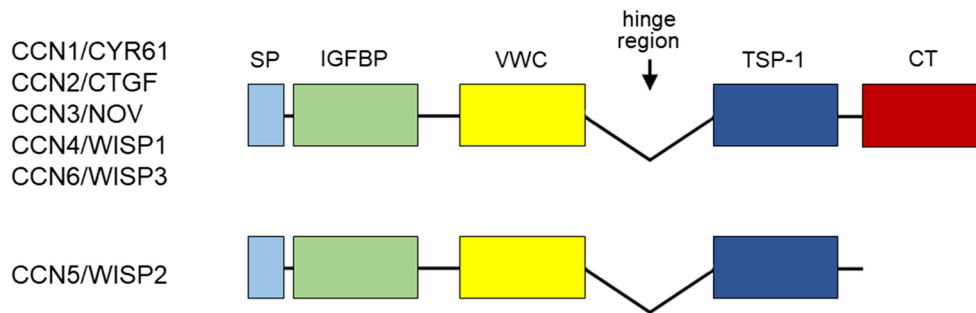

Fig. 1 Modular organization of members of the CCN family of matricellular proteins. All CCN family members contain conserved domains of N-terminal secretory signal peptide (SP), insulin-like growth factor binding protein (IGFBP), von Willebrand factor type C

repeat (vWC), thrombospondin type 1 repeat (TSR), and a cysteine knot motif within the C-terminal (CT). CCN5 is the only member of the family that does not contain the C-terminal cysteine knot (CT). The hinge region is highly variable among the family members

phenotype that included thinning of the cortical bone (Zhao et al. 2018). Ablation of *Ccn2/Ctgf* in osteoblasts using *Osteocalcin-Cre* also led to a mild low bone mass phenotype, but was only seen in males and not in females; cortical bone was unaffected (Canalis et al. 2010a, b). While *Ccn3/Nov* is expressed in mature osteoblasts (Matsushita et al. 2013), *Ccn3/Nov*^{-/-} mice showed no skeletal abnormality (Canalis et al. 2010a, b, Matsushita et al. 2013). However, they exhibit accelerated bone regeneration (Matsushita et al. 2013), consistent with studies showing that *Ccn3/Nov* inhibits osteoblast differentiation (Kawaki et al. 2011, Rydzziel et al. 2007). In contrast, in *Ccn4/Wisp1*^{-/-} mice, cortical bone thickness, cross-sectional area, and endocortical mineral apposition rate are significantly reduced (Maeda et al. 2015). Hence, some CCN family members (CCN1/Cyr61, CCN2/Ctgf, CCN4/Wisp1) have anabolic functions in bone, while CCN3/Nov has opposing functions.

Several studies have investigated the potential role of CCN5 in bone. Kumar et al. first identified *Ccn5* mRNA in primary cultures of human osteoblasts (Kumar et al. 1999). *In situ* hybridization showed CCN5 as being highly expressed in bone-forming osteoblasts and in alkaline phosphatase positive bone marrow cells (Kumar et al. 1999). A later study by Kawaki et al. showed with immunohistochemistry that CCN5 protein co-localized with osteocalcin positive regions in mouse calvaria (Kawaki et al. 2011). *In vitro* functional studies showed that CCN5 protein promoted the adhesion of osteoblasts, inhibited the binding of fibrinogen to purified integrin receptors, and inhibited the production of osteocalcin by rat osteoblast-like Ros 17/2.8 cells (Kumar et al. 1999). Additionally, CCN5-treated primary murine calvaria osteoblasts showed increased mineralization with upregulation of the osteogenic genes Osterix, Alp, and Bsp (Kawaki et al. 2011). While these studies provide good support for anabolic function of CCN5 in bone, direct *in vivo* evidence for CCN5 is not available. The goal of this study is to generate *Ccn5*^{-/-} mice to enable characterization of CCN5 function in bone and other tissues.

Methods

Vertebrate animals

Ccn5 knockout mice (*Ccn5*^{LacZ}) were generated from targeted ES cells with the vector map shown in Fig. 2, obtained from the Knockout Mouse Project (KOMP) repository at UC Davis (*Wisp2tm1(KOMP)Vlcg*). ES cells were injected into C57Bl6J blastocysts, and germline transmission was confirmed at UC Davis. All animals were treated in accordance with the National Institutes of Health guidelines for care and use of animals, and approved by the UCLA Institutional Animal Care and Use Committee.

LacZ staining

Whole-mount LacZ staining was performed on *Ccn5* heterozygous (*Ccn5*^{LacZ/WT}) mice to examine the expression pattern

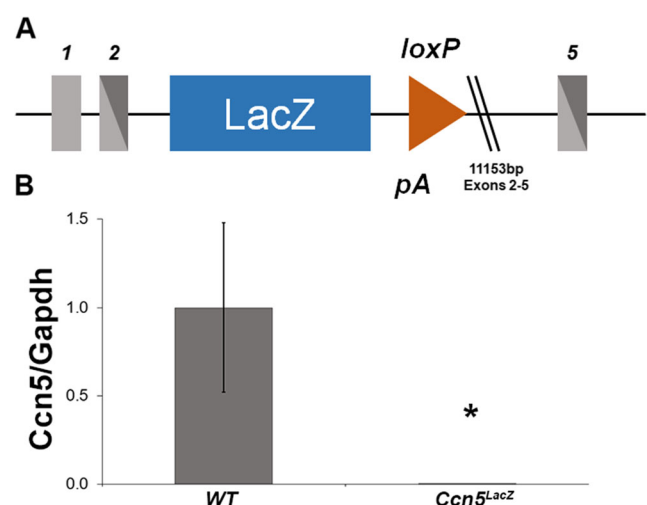

Fig. 2 a Schematic of reporter-tagged deletion allele for CCN5 using ES cells obtained from IMPC (*Wisp2tm1(KOMP)Vlcg*), LacZ cassette is inserted directly behind ATG starting codon located in Exon2. b *Ccn5* gene expression in mouse tibia showing no *Ccn5* mRNA in *Ccn5*^{LacZ/LacZ} mice

of *Ccn5* in bone. A standard X-gal staining protocol was utilized as previously described (Jiang et al. 2017). Briefly, mice were euthanized and hind limbs were dissected and fixed in 0.2% glutaraldehyde LacZ fixative solution. After fixation, the tissue was washed and stained with X-gal overnight at 37 °C. After X-gal staining, the tissue was washed and fixed in 4% paraformaldehyde and decalcified in 19% EDTA. After decalcification, the tissue was embedded in paraffin and sectioned. Sectioned slides were counterstained with Eosin and visualized with on a microscope (Model BX60F; Olympus Optical Co., Japan) equipped with a digital camera (Model 01-RET-OEM-F-CLR-12; QImaging, Surrey, Canada). Photomicrographs were taken with a Nikon Ti-DH Microscope. Images were processed in Photoshop (Adobe).

Micro-computed tomography (μ -CT) analysis

Bone parameters were quantified on femurs from mutant and wild type (*Ccn5*^{+/+}) mice by μ -CT (Skyscan1172; Bruker MicroCT, Kontich, Belgium) using CTAn (v.1.14.4) and CTVol (v.2.2) software. The microradiography unit was set to an energy level of 55 kVp, intensity of 181 μ A, and 900 projections; specimens were scanned at a 10 μ m³ voxel resolution. A three-dimensional reconstruction was generated with NRecon software (Bruker MicroCT, Kontich, Belgium) from the set of scans. The regions of interest (ROI) of trabecular bone were defined as the areas between 1 mm and 3 mm from the growth plate in the metaphyseal region of distal femurs. The ROI of cortical bone was defined as 0.75 mm segments of the femoral middle-diaphysis. All ROIs were drawn automatically and trabecular regions were assessed for bone mineral density (BMD) and bone volume fraction (bone volume/total volume, BV/TV). The mid-shaft average cortical bone thickness (Ct.Th) values were analyzed. All abbreviations and nomenclature are standardized according to previously published guidelines (Bouxsein et al. 2010).

In vivo gene expression

For *in vivo* samples, femurs and tibiae were dissected and soft tissue was removed. Bones were then cut to remove both 3 mm termini, and the bone marrow was flushed out with cold PBS until the cortical bone became white. The resulting cortical bone was flash frozen with liquid nitrogen, homogenized with a grinder, and re-suspended in 1 mL Trizol (Thermo Scientific, MA). Total RNA was isolated by the phenol-chloroform method and converted to cDNA using SuperScript III (Thermo Scientific). cDNA was amplified and quantified using Maxima SYBR Green qPCR master mix (Thermo Scientific). Analysis of *Ccn5* gene expression was done using following primers: 5'-TGTGTGAC CAGGCAGTGATG-3' and 5'-GGATACTCGGGTGG CTATGC-3'. *Ccn5* expression is then normalized to the

housekeeping gene *Gapdh*: 5'-CTTTGGCATTGTGG AAGGGC-3' and 5'-CAGGGATGATGTTCTGGGCA-3'.

Statistical analysis

The data represent results from at least three independent experiments, and are presented as the mean \pm standard deviation (SD). Statistical significance between experimental and control groups was compared by Student t test. For experiments with more than two parameters, one-way analysis of variance (ANOVA) followed by Tukey's post hoc analysis was used. A value for $p < 0.05$ was considered significant.

Results

Ccn5 expression in bone *in vivo*

The *Ccn5*^{LacZ} mouse used for this study is a knockout/knock-in where exon 2 to exon 5 of the *Ccn5* gene is knocked-out and is replaced with a LacZ cassette (Fig. 2a). We confirmed the absence of *Ccn5* mRNA in the limbs of *Ccn5*^{LacZ/LacZ} mice using qPCR (Fig. 2b). *Ccn5*^{LacZ/WT} heterozygous mice did not present any obvious phenotypes. LacZ is expected to be expressed instead of *Ccn5* where and whenever *Ccn5* is being expressed. Thus we examined the presence of LacZ in *Ccn5*^{LacZ/WT} heterozygous mice as a reporter for *Ccn5* expression. Given previous studies showing *Ccn5* expression in bone (Kawaki et al. 2011), we examined LacZ expression in this tissue. In trabecular bone, we did not observe any significant staining in any of the compartments in *Ccn5*^{LacZ/WT} heterozygous mice (Fig. 3a). However, LacZ staining was very strong in bone periosteal cells (Fig. 3b). We did not see any staining in the bone marrow stromal cells, osteocytes, osteoblasts or endosteal cells.

Ccn5^{LacZ/LacZ} bone phenotype

We examined the bone phenotype of *Ccn5*^{LacZ/LacZ} mice using μ CT. When compared to WT littermates, we found that loss of *Ccn5* had no apparent effect on trabecular bone mineral density (BMD) or bone volume fraction (BV/TV). Additionally, loss of *Ccn5* did not have an effect on cortical bone thickness (Fig. 4). These observations are consistent with subsequent skeletal analyses performed by International Mouse Phenotyping Consortium (IMPC).

Discussion

In this study, we found LacZ under the control of the endogenous *Ccn5* regulatory sequences to be highly expressed in periosteal cells in adult bone, but we did not observe any LacZ

Fig. 3 LacZ staining of 3 month old $Ccn5^{LacZ/WT}$ heterozygous mice: **a** trabecular bone; **b** cortical bone. Strong LacZ staining on the periosteal surface of cortical bone. No staining was observed in any other compartment

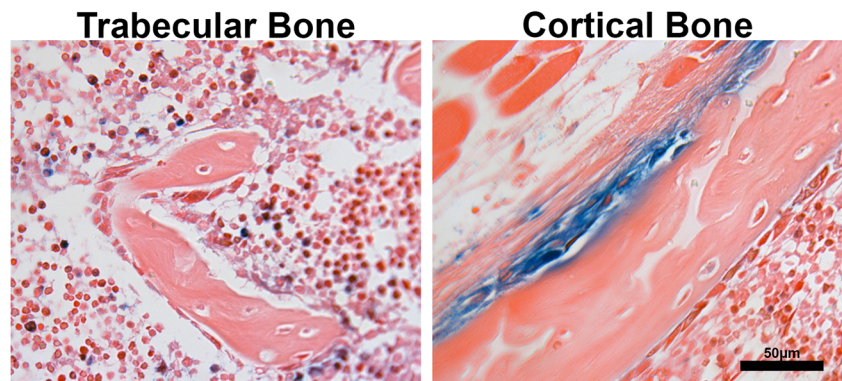

staining in any other compartment of bone. These data are somewhat contradictory with previous studies showing $Ccn5$ to be expressed in bone-forming osteoblasts and alkaline phosphatase positive bone marrow cells (Kumar et al. 1999). Several factors can contribute to this difference, as the previous study was done in human fetal femoral growth plate. Similarly, Kawaki et al. found co-localization of CCN5 protein with osteocalcin in neonatal mouse calvaria. It is conceivable that the pattern of CCN5 expression differs in neonatal and adult mice. Furthermore, we did not specifically examine calvarial expression. In this study we found that $Ccn5/LacZ$ expression is localized on the periosteal surface of adult bone, which has not been previously reported.

Currently there remains some debate as to the expression profile of $Ccn5$ during development. Jones et al., using immunohistochemistry and qRT-PCR, showed that $Ccn5$ is

expressed in all the organs examined and is specifically high in skeletal muscle and epidermis of the skin (Jones et al. 2007). Data from Eurexpress/Genepaint showed a general hazy background staining for $Ccn5$ with *in situ* hybridization. It is very possible that $Ccn5$ is expressed at low levels in many tissues during development, which can be difficult to detect with *in situ* hybridization, but can be easily detected with qRT-PCR. Additionally, since CCN5 is secreted, the protein may accumulate in the extracellular matrix and be detected with immunohistochemistry. In the future we plan to use our LacZ reporter mice to examine in detail the pattern of $Ccn5$ expression during development.

IMPC analysis showed that $Ccn5^{LacZ/LacZ}$ mice had a normal phenotype in most organs. The only abnormal phenotype exhibited by $Ccn5^{LacZ/LacZ}$ mice was a change in auditory brainstem response in the IMPC analysis. These data are a

Fig. 4 Micro-CT analysis of 3 month old $Ccn5^{LacZ/LacZ}$ mice. **a** Representative μ CT 3D reconstruction of 3 month old mice. Quantitative analysis of bone morphology with μ CT (**b-d**). No differences were seen between WT and $Ccn5^{LacZ/LacZ}$ mice in **b** BMD, **c** BV/TV and **d** Cortical bone thickness

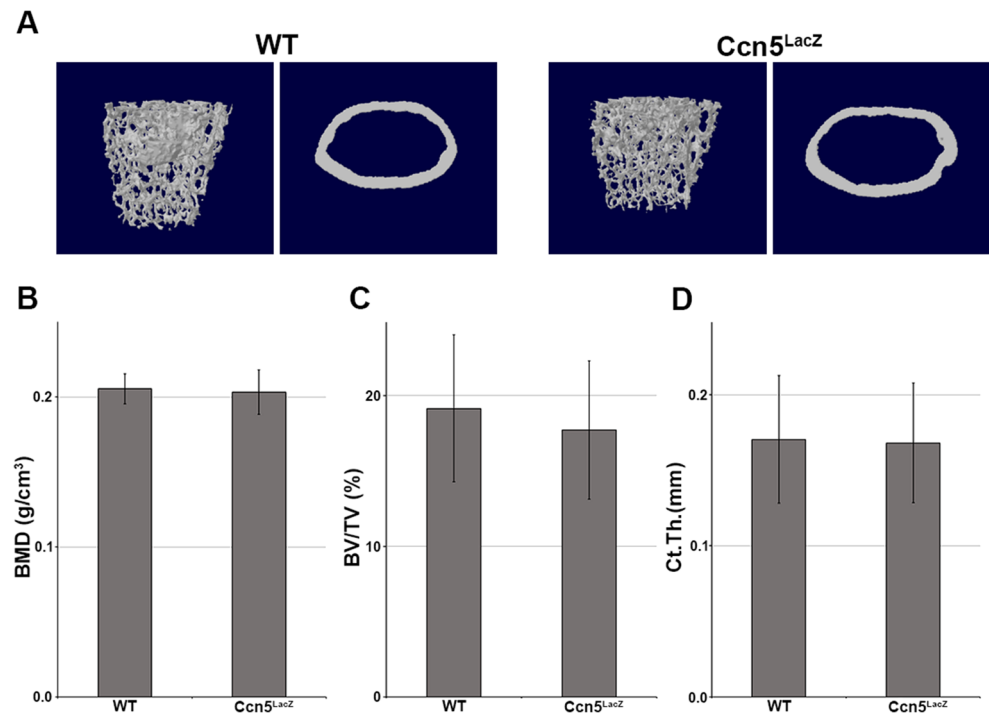

significant departure from a previous observation indicating that both *Ccn5*-null (not published) and overexpressing mice are embryonic lethal (Myers et al. 2012, Russo and Castellot 2010). Since the *Ccn5*-null mouse strain described previously is not available, it is difficult to explain the drastically different phenotypes. The *Ccn5*^{LacZ} strain we analyzed represents a loss of function allele since all of the conserved protein coding exons are replaced by LacZ. There have been other examples of genetic modifications within the CCN family that showed major differences in phenotypes. These are typically the result of incomplete knockout of the gene and the production of a mutant protein that can have antagonistic effects. CCNs are unique in that all members share a similar modular structure, and within the genome, each exon usually encodes one of the modular domains of the protein. Most of the exons are in frame, so deletion of any one or multiple exons often does not result in a frame shift in the remaining mRNA (Jiang et al. 2017). For example, *Ccn3/Nov* knockout mice where exons 1–3 (Matsushita et al. 2013) and exons 1–5 (Canalis et al. 2010a, b) were deleted showed no apparent skeletal phenotype (Canalis et al. 2010a, b, Matsushita et al. 2013), while *Ccn3/Nov* mutant mice in which exon 3 alone was deleted (*Nov*^{del3}) produced multiple skeletal changes characterized by overgrowth of multiple skeletal elements (Heath et al. 2008). In this latter strain, in-frame exon skipping generates a form of CCN3 lacking the vWC domain.

Previous papers have demonstrated that CCN5 enhances osteogenic differentiation *in vitro* through both Wnt (Grünberg et al. 2014, Robinson et al. 2006) and integrin (Kumar et al. 1999) signaling. *Ccn5* expression is directly upregulated by canonical Wnt signaling and CCN5 has been shown to attenuate Wnt signaling *in vitro* (Grünberg et al. 2014). In this study we examined the effect of *Ccn5* on skeletal tissues using *Ccn5*^{LacZ/LacZ} mice. We found that *Ccn5*^{LacZ/LacZ} mice are viable with a normal skeletal phenotype; this is consistent with IMPC skeletal analysis. This lack of phenotype suggests that *Ccn5* is dispensable for bone homeostasis, in spite of its strong expression in the periosteum (this study), and strong expression in different bone compartments reported by other groups during neonatal development. The lack of a discernable phenotype does not signify that *Ccn5* is unimportant in bone biology. *Ccn3/Nov* knockout mice did not exhibit an overt skeletal phenotype but were shown to have accelerated bone healing after injury (Canalis et al. 2010a, b, Matsushita et al. 2013). This also could be the case for *Ccn5*. Thus, we plan to conduct future experiments that would induce stress, via fracture, mechanical loading and ovariectomy, to further examine the role of *Ccn5* in bone biology *in vivo*.

Acknowledgements This work was supported by NIAMS/NIH grants R01 AR052686 and R21 AR071734 to KML.

References

- Bouxsein ML, Boyd SK, Christiansen BA, Guldberg RE, Jepsen KJ, Müller R (2010) Guidelines for assessment of bone microstructure in rodents using micro-computed tomography. *J Bone Miner Res* 25:1468–1486
- Canalis E, Smerdel-Ramoya A, Durant D, Economides AN, Beamer WG, Zanotti S (2010a) Nephroblastoma overexpressed (Nov) inactivation sensitizes osteoblasts to bone morphogenetic protein-2, but nov is dispensable for skeletal homeostasis. *Endocrinology* 151: 221–233
- Canalis E, Zanotti S, Beamer WG, Economides AN, Smerdel-Ramoya A (2010b) Connective tissue growth factor is required for skeletal development and postnatal skeletal homeostasis in male mice. *Endocrinology* 151:3490–3501
- Chen PC, Cheng HC, Yang SF, Lin CW, Tang CH (2014) The CCN family proteins: modulators of bone development and novel targets in bone-associated tumors. *Biomed Res Int* 2014:437096
- Delmolino LM, Castellot JJ (1997) Heparin suppresses *sgk*, an early response gene in proliferating vascular smooth muscle cells. *J Cell Physiol* 173:371–379
- Grünberg JR, Hammarstedt A, Hedjazifar S, Smith U (2014) The Novel Secreted Adipokine WNT1-inducible Signaling Pathway Protein 2 (WISP2) Is a Mesenchymal Cell Activator of Canonical WNT. *J Biol Chem* 289:6899–6907
- Heath E, Tahri D, Andermarcher E, Schofield P, Fleming S, Boulter CA (2008) Abnormal skeletal and cardiac development, cardiomyopathy, muscle atrophy and cataracts in mice with a targeted disruption of the *Nov* (*Ccn3*) gene. *BMC Dev Biol* 8:18
- Jiang J, Hu Z, Lyons KM (2017) Design and Analysis of CCN Gene Activity Using CCN Knockout Mice Containing LacZ Reporters. *Methods Mol Biol* 1489:325–345
- Jones JA, Gray MR, Oliveira BE, Koch M, Castellot JJ (2007) CCN5 expression in mammals: I. Embryonic and fetal tissues of mouse and human. *J Cell Commun Signal* 1:127–143
- Kawaki H, Kubota S, Suzuki A, Suzuki M, Kohsaka K, Hoshi K, Fujii T, Lazar N, Ohgawara T, Maeda T, Perbal B, Takano-Yamamoto T, Takigawa M (2011) Differential roles of CCN family proteins during osteoblast differentiation: Involvement of Smad and MAPK signaling pathways. *Bone* 49:975–989
- Kumar S, Hand AT, Connor JR, Dodds RA, Ryan PJ, Trill JJ, Fisher SM, Nuttall ME, Lipshutz DB, Zou C, Hwang SM, Votta BJ, James IE, Riemann DJ, Gowen M, Lee JC (1999) Identification and cloning of a connective tissue growth factor-like cDNA from human osteoblasts encoding a novel regulator of osteoblast functions. *J Biol Chem* 274: 17123–17131
- Maeda A, Ono M, Holmbeck K, Li L, Kilts TM, Kram V, Noonan ML, Yoshioka Y, McNerny EM, Tantillo MA, Kohn DH, Lyons KM, Robey PG, Young MF (2015) WNT1-induced Secreted Protein-1 (WISP1), a Novel Regulator of Bone Turnover and Wnt Signaling. *J Biol Chem* 290:14004–14018
- Matsushita Y, Sakamoto K, Tamamura Y, Shibata Y, Minamizato T, Kihara T, Ito M, Katsube K, Hiraoka S, Koseki H, Harada K, Yamaguchi A (2013) CCN3 protein participates in bone regeneration as an inhibitory factor. *J Biol Chem* 288: 19973–19985
- Myers RB, Rwayitare K, Richey L, Lem J, Castellot JJ (2012) CCN5 Expression in mammals. III. Early embryonic mouse development. *J Cell Commun Signal* 6:217–223
- Parisi MS, Gazzo E, Rydzziel S, Canalis E (2006) Expression and regulation of CCN genes in murine osteoblasts. *Bone* 38: 671–677
- Pennica D, Swanson TA, Welsh JW, Roy MA, Lawrence DA, Lee J, Brush J, Taneyhill LA, Deuel B, Lew M, Watanabe C, Cohen RL, Melhem MF, Finley GG, Quirke P, Goddard AD, Hillan KJ, Gurney

- AL, Botstein D, Levine AJ (1998) WISP genes are members of the connective tissue growth factor family that are up-regulated in wnt-1-transformed cells and aberrantly expressed in human colon tumors. *Proc Natl Acad Sci U S A* 95:14717–14722
- Robinson JA, Chatterjee-Kishore M, Yaworsky PJ, Cullen DM, Zhao W, Li C, Kharode Y, Sauter L, Babij P, Brown EL, Hill AA, Akhter MP, Johnson ML, Recker RR, Komm BS, Bex FJ (2006) Wnt/beta-catenin signaling is a normal physiological response to mechanical loading in bone. *J Biol Chem* 281:31720–31728
- Russo JW, Castellot JJ (2010) CCN5: biology and pathophysiology. *J Cell Commun Signal* 4:119–130
- Rydziel S, Stadmeier L, Zanotti S, Durant D, Smerdel-Ramoya A, Canalis E (2007) Nephroblastoma overexpressed (Nov) inhibits osteoblastogenesis and causes osteopenia. *J Biol Chem* 282:19762–19772
- Zhao G, Huang BL, Rigueur D, Wang W, Bhoot C, Charles KR, Baek J, Mohan S, Jiang J, Lyons KM (2018) CYR61/CCN1 regulates sclerostin levels and bone maintenance. *J Bone Miner Res.* <https://doi.org/10.1002/jbmr.3394>