

UC Santa Cruz

UC Santa Cruz Previously Published Works

Title

Attitude control for optimal generation of energy from multiple energy sources

Permalink

<https://escholarship.org/uc/item/4n28t3vh>

ISBN

9780878232413

Authors

Sanfelice, RG
Campa, G
Robles, MA

Publication Date

2012-08-20

Peer reviewed

Attitude Control for Optimal Generation of Energy From Multiple Energy Sources

Manuel Robles, Ricardo G. Sanfelice and Giampiero Campa

Abstract

This paper presents the design of algorithms and a low-cost experimental setup for a graduate course on hybrid control systems offered to non-electrical engineering majors. The purpose of the developed hands-on educational kit is two-fold. First, it aims at incorporating in the classroom a basic yet important problem emerging in generation of renewable energy of current global relevance: optimal extraction of solar and wind energy. Second, it introduces non-electrical engineering majors to issues of implementation of advanced control algorithms. The setup consists of a rotating base with an elevation arm to orient the attitude of modular energy collectors mounted at its tip. The base and arm are linked to a drive train that is powered by a small servo motor and provides the propulsion to orient the attitude of the setup. Solar and wind turbine modules can be attached to the arm. An Arduino microcontroller and associated sensors are used to control both the base and the arm. A Matlab/Simulink module has been created for this purpose. Students are able to design hybrid controllers to stabilize the attitude of the setup in order to maximize energy extraction. In this paper we present results on extraction of solar energy using solar tracking algorithms. The setup and algorithms have been tested in a hybrid control class offered to graduate students in aerospace and mechanical engineering.

I. INTRODUCTION

As renewable energy becomes more widely available, a need for autonomous and standalone systems for energy extraction in remote locations will increase. However, the margins for energy collection are still low; the most efficient solar cells only achieve 40% efficiency. To maximize energy collection, it is necessary to create smart controllers to achieve optimal energy collection and minimize operational power requirements. In this paper, we present a prototype and associated algorithms for control education using Matlab/Simulink based on energy generation from solar sources. It consists of a computer-controlled collector of solar and wind energy sources. Using an Arduino embedded system, two modules consisting of a solar and wind collector mounted to the rotating base are individually controlled via a hardware-in-the-loop architecture interfacing with Matlab. A control law is designed for each module to maximize energy collection using hybrid control theory [4].

Control courses are the main target for educational integration of the developed hands-on kit. The introduction of this real-life renewable energy challenge in such courses will provide a practical application to solve using classroom control theory. Currently, the kit has been incorporated in a graduate course on hybrid control systems as a final project assignment. The current assignment focuses on extraction of solar energy using solar tracking algorithms, but a follow-up assignment on wind energy analysis will be developed. In this assignment, the students are asked to perform the following tasks:

M. Robles and R. G. Sanfelice are with the Department of Aerospace and Mechanical Engineering, University of Arizona, 1130 N. Mountain Ave, AZ 85721. Email: robles,ricardo@u.arizona.edu
G. Campa is with Mathworks. Email: Giampiero.Campa@mathworks.com

- *Task 1: Modeling of the mechanical components of the setup including the effect of the servomotors.* In this task, the students derive a simple mathematical model capturing the planar motion of each component of the setup, leading to 3D attitude motion.
- *Task 2: Modeling of power generation using solar and wind extraction modules.* In this task, the students obtain a relationship between the solar and wind power in the environment and the power provided to a constant resistive load.
- *Task 3: Analysis and design of a solar tracking algorithm.* In this task, the students become familiar with solar equations and implement an algorithm in Matlab/Simulink to determine the optimal orientation of a solar collector based on those equations. Using this orientation as a reference, the student design a hybrid control algorithm to track the desired orientation by solving the problem of stabilizing a point on a circle robustly.
- *Task 4: Simulation of solar tracking algorithm.* The students simulate in Matlab/Simulink the control algorithm designed in Task 3 for the plant model derived in Task 2.
- *Task 5: Implementation in setup and experiments.* The students reconfigure the control algorithm implemented in Matlab/Simulink in Task 3 to operate on the real setup.

In addition to the hybrid control course, the setup will be incorporated in a classical feedback control course for Aerospace and Mechanical Engineering seniors and in a course on stability and control of aerospace for Aerospace Engineering seniors.

The remainder of the paper is organized as follows. Motivation to the solar tracking control problem is given in Section II. A tracking algorithm is given in Section II-A and later applied to a simplified model of the setup in Section II-B. The details of the constructed setup are given in Sections II-C. Results from experiments are given in Section II-D.

II. MOTIVATIONAL PROBLEM: SOLAR TRACKING

The problem of tracking the position of the sun is considered in this paper. A small modular prototype is designed and manufactured to generate energy via a solar cell configuration utilizing two degrees of freedom for changing the attitude and orientation. A solar cell is attached to the rotating arm of the device and the collector works by aligning with the normal position of the sun. As the sun moves throughout the day, the system has to be corrected to remain inline with the path of the solar rays.

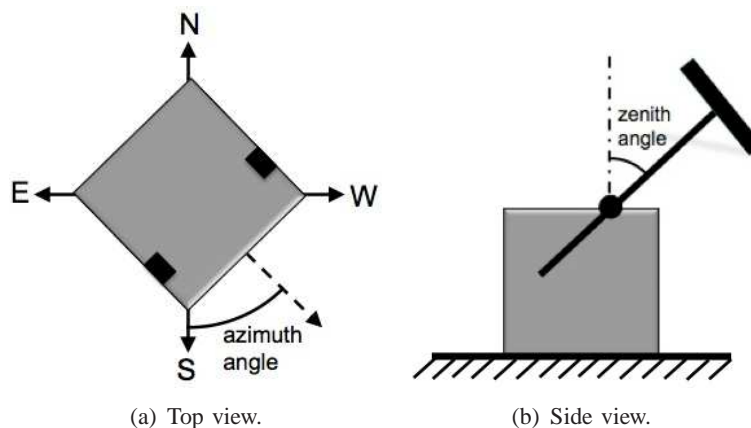

Fig. 1. (a) The azimuth angle is measured between the front normal vector and the South direction. (b) The zenith angle is measured between the arm of the collector and the vertical axis.

A. Introduction to a Solar Tracking Algorithm

Before a hybrid control system is implemented, the reference position of the sun must be determined. The resulting reference position will be the output of the reference generator for the hybrid plant, in this case the solar collector, to track. The method used here will create a reference trajectory for the plant to track. The methods to create controllers for tracking and analyze stability are outlined in [5]. To maximize solar energy input, the angle between the unit vector normal to the plane of the lens (\hat{n}_c) and the unit vector of the solar rays (\hat{n}_s) must be minimized. The parameters used to derive the solar vector are: local time t , hour angle ω , declination angle δ , and local latitude λ . Hour and declination angle are calculated using (1) and (2), respectively. The solar position calculations are outlined in [3] and [1]. The position angles of the solar cooker apparatus, azimuth ϕ and zenith β , are displayed in Fig. 2 and represent the position of the solar cooker arm with respect to the vertical and horizontal planes.

$$\omega(t) = (360/24)t \quad (1)$$

$$\delta = 23.45 \sin(360(284 + n)/365) \quad (2)$$

The solar vector is found using (3) as a function of the solar parameters and the lens normal vector is found as a function of the solar cooker angles.

$$\hat{n}_s = (\cos \delta \cos \omega \cos \lambda + \sin \delta \sin \lambda, -\cos \delta \sin \omega, -\cos \delta \cos \omega \sin \lambda + \sin \delta \cos \lambda) \quad (3)$$

$$\hat{n}_c = (\cos \beta, -\sin \beta \sin \phi, -\sin \beta \cos \phi) \quad (4)$$

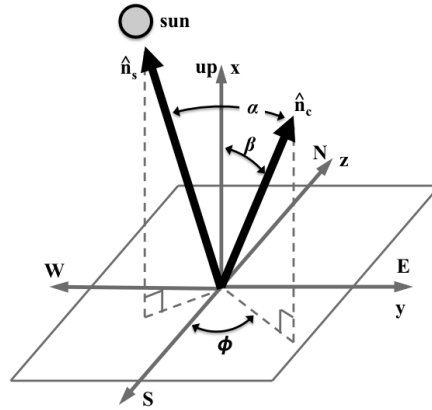

Fig. 2. Cartesian view of the solar vector \hat{n}_s and lens normal vector \hat{n}_c projected onto respective planes.

The minimization of the incidence angle α is accomplished by minimizing the difference between the respective components of \hat{n}_c and \hat{n}_s . The independent variables of the minimization are β and ϕ , which can be controlled directly by the collector. The residues of (3)-(4) are setup in vector M according to

$$M := \begin{bmatrix} | -\cos \delta \sin \omega(t) + \sin \beta^* \sin \phi^* | \\ | -\cos \delta \cos \omega(t) \sin \lambda + \sin \delta \cos \lambda + \sin \beta^* \cos \phi^* | \end{bmatrix}. \quad (5)$$

The MATLAB script `ref_angle` will take the inputs w , δ , λ , n , and $t = t_{loc}$ to obtain M . Then, the vector in (5) has two equations with two unknowns, which are the reference angles β^* and ϕ^* , and the script uses the argument `fsolve(M)` to solve the reference angles. The reference angles are then mapped to two separate and decoupled planes for tracking on the unit circle. The algorithm used to create the four points on the two Cartesian planes is defined by

$$\begin{aligned} w_1 &= \cos \beta^* \\ w_2 &= \sin \beta^* \end{aligned} \quad (6)$$

$$\begin{aligned} w_3 &= \cos \phi^* \\ w_4 &= \sin \phi^* \end{aligned} \quad (7)$$

The target coordinates w_i are then passed to the hybrid control system as the output of the exosystem reference generator and the system stabilizes when the control angles β and ϕ converge to the target angles β^* and ϕ^* created by the solar tracking algorithm, respectively, for a given time. The output of this reference generator are the reference coordinates of β^* and ϕ^* mapped onto two separate Cartesian plans for tracking of the sun. The resulting reference coordinates take the form $r = [w_1 \ w_2 \ w_3 \ w_4]^T$, where w_1 and w_2 are the coordinates for the zenith angle β and w_3 and w_4 are the coordinates for the azimuth angle ϕ , for the system to track.

Several issues have to be addressed during the design of the controller. The controller has to decide the most efficient path to reach the target angles and switch direction when needed. However, the system is susceptible to becoming trapped in decision conflict regions when perturbations are introduced, thus requiring a level of robustness within the controller. These issues cannot be resolved using an explicitly discrete-time or explicitly continuous-time controller. As a result, a hybrid system of both elements is implemented to meet these goals. Students in the department will have the choice to choose this project in the introduction to control system design course. In this course, students learn the concepts of control theory and this project will enable them to apply the background they learned in the classroom and implement into a laboratory setting. Students will develop a mathematical model of the system and simulate the kinematics of the system. They can test their control algorithms with these models before they are ready to test on the actual collector.

B. Simplified Model of Solar Collector with Tracking Algorithm (Tasks 1 & 2)

Next, the kinematics of the collector are modeled as a hybrid plant [2] which will track a reference trajectory on the unit circle. Suppose a continuous plant whose purpose is to track a reference trajectory on the unit circle. To model a system rotating clockwise (CW), the kinematics of the system can be represented by the set of ordinary differential equations (ODEs)

$$\begin{aligned} \dot{\xi}_1 &= \xi_2 \\ \dot{\xi}_2 &= -\xi_1, \end{aligned} \quad (8)$$

which will hold true as long as ξ_1 and ξ_2 remain on the unit circle.

For an initial condition of $\xi(0,0)$ that is on the unit circle, the solution ϕ_p to these dynamics will result in a signal CW rotating around the unit circle. To rotate around the unit circle counter clockwise (CCW), simply invert the signs of $\dot{\xi}_1$ and $\dot{\xi}_2$, and the resulting solution is a signal rotating CCW on the unit circle. By introducing a scalar control input u_c to the plant kinematics, the plant takes the form

$$\begin{aligned} \dot{\xi}_1 &= u_c \xi_2 \\ \dot{\xi}_2 &= -u_c \xi_1. \end{aligned} \quad (9)$$

This tracking method brings a unique problem as the signs of the states ξ_1 and ξ_2 on the Cartesian plane change when they shift between the four quadrants. A second major issue is tracking a reference signal that is 180 degrees away from the state of the plant. The control method used here will not be robust to measurement noise at this critical area and could result to be “stuck” in this position. This set of challenges will provide a unique problem for the students to converge on a solution during their analysis of the problem. Suppose the reference signal to track is the constant $r = 1 := [1 \ 0]^\top$. The discontinuous feedback controller u_c will ensure the plant ξ will rotate in the optimal direction to reach 1. Since this feedback method is not robust to arbitrarily small measurement noise e when points are near -1 , the results of $\text{sgn}(\xi_2 + e)$ will push solutions towards -1 and end in this aforementioned “stuck” scenario. The challenges with this unique tracking problem are explored in [6]. To mitigate this hysteresis behavior, a supervisor controller with two modes is used for pushing the state of the plant towards the stabilization point when away from -1 . Now introduce a discrete logic variable $q \in \{1, 2\}$ that will be used for assuring the value of u “agrees” with the direction for the system to turn. For the case when $q = 1$, the state ξ is pushed away from -1 in the CW direction. And for the case when $q = 2$, the state ξ is already pushed away from -1 and is pushed to the stabilization point. To achieve robust global asymptotic stability, the controller algorithm will perform as in Table I.

TABLE I
ALGORITHM USED FOR TRACKING ON UNIT CIRCLE.

Controller	Condition	u Signal
u	$\xi_1 \leq -1/3, \quad q = 1$	ξ_1
u	$\xi_1 \geq -2/3, \quad q = 2$	ξ_2

To define the plant model for the solar collector, suppose the state of the system is defined as $\xi = [\xi_1 \ \xi_2 \ \xi_3 \ \xi_4]^\top$, where ξ_1 and ξ_2 are the mapped coordinates of the ϕ angle onto the Cartesian plane and ξ_3 and ξ_4 are the mapped coordinates of the β angle onto the Cartesian plane. Then the data of the plant \mathcal{H}_p takes the form below, where the dynamics are described by $\dot{\xi}$ and the ODEs of the system

$$\begin{aligned}\dot{\xi}_1 &= u_\beta \xi_2 \\ \dot{\xi}_2 &= -u_\beta \xi_1 \\ \dot{\xi}_3 &= u_\phi \xi_4 \\ \dot{\xi}_4 &= -u_\phi \xi_3,\end{aligned}$$

where the points (ξ_1, ξ_2) and (ξ_3, ξ_4) are on the unit circle. An additional q variable is added and are labeled as q_1 and q_2 for each degree of freedom.

To track the signals (6)-(7) from the exosystem, the attitude of the apparatus is stabilized to the position of the sun such that $(\xi_1, \xi_2) = (w_1, w_2)$ and $(\xi_3, \xi_4) = (w_3, w_4)$. To achieve this on the unit circle, a coordinate transformation method used. Using the transformation

$$\begin{bmatrix} z_1 \\ z_2 \end{bmatrix} = \begin{bmatrix} \xi_1 w_1 - \xi_2 w_2 \\ w_2 \xi_1 + w_1 \xi_2 \end{bmatrix}, \quad (10)$$

$$\begin{bmatrix} z_3 \\ z_4 \end{bmatrix} = \begin{bmatrix} \xi_3 w_3 - \xi_4 w_4 \\ w_4 \xi_3 + w_3 \xi_4 \end{bmatrix}, \quad (11)$$

the new dynamics of the plant take the form

$$\begin{aligned}\dot{z}_1 &= \tilde{u}_\beta z_2 \\ \dot{z}_2 &= -\tilde{u}_\beta z_1 \\ \dot{z}_3 &= \tilde{u}_\phi z_4 \\ \dot{z}_4 &= -\tilde{u}_\phi z_3,\end{aligned}\tag{12}$$

where \tilde{u}_β and \tilde{u}_ϕ are the new control inputs for each degree of freedom. Now for when $(\xi_1, \xi_2) = (w_1, w_2) \iff (z_1, z_2) = (1, 0)$ and $(\xi_3, \xi_4) = (w_3, w_4) \iff (z_3, z_4) = (1, 0)$. Thus, the state of the original plant ξ will stabilize to w .

The control laws \tilde{u}_β and \tilde{u}_ϕ determine the optimal path to reach the reference trajectory through a coordinate transformation by stabilizing to the point $(z_1, z_2) = (1, 0)$ and $(z_3, z_4) = (1, 0)$ on the unit circle for each degree of freedom. The algorithm in Table II is used to determine the control law \tilde{u}_β and \tilde{u}_ϕ used in the plant dynamics (12).

TABLE II
ALGORITHM USED 2-DOF SOLAR TRACKING ON UNIT CIRCLE.

Controller	Condition	\tilde{u} Signal
\tilde{u}_β	$z_1 \leq -1/3, \quad q_1 = 1$	z_1
\tilde{u}_β	$z_1 \geq -2/3, \quad q_1 = 2$	z_2
\tilde{u}_ϕ	$z_3 \leq -1/3, \quad q_2 = 1$	z_3
\tilde{u}_ϕ	$z_3 \geq -2/3, \quad q_2 = 2$	z_4

C. Testbed for Incorporation of Solar Tracking System in Control Education

A prototype of the solar tracking module was manufactured using a 3-D printer and used as a testbed for validating the results of the solar tracking algorithms derived by the students.

1) *Design and Build of Prototype:* The prototype was designed in a CAD package and then exported to the 3-D printer to be built one 0.01-inch layer of material at a time. The resulting product can be compared with the CAD design in Figure 3.

Before the construct of the physical prototype, a 2-D CAD drawing was developed and analyzed to ensure that all systems would be well-integrated into the final design. The final mechanical drawings used for the 3-D printer can be seen below in Figure 4.

Since the system was built using this method, a sprocket and a gear tooth profile were also integrated into the rotating arm and base, respectively. The rotating arm is then actuated by a plastic chain used for robotics. The sprocket on the rotating arm is driven by this chain which is also attached to a second small sprocket that is coupled to a stepper motor. This configuration can be seen in Figure 5.

Now for the actuation of the rotating base, a second stationary base was designed for the system to rotate about and also serve as the housing for the embedded system electronics. This stationary base also contains a second stepper motor with a small gear coupled to its shaft to actuate the rotating base. This can be seen in more detail in Figure 6.

The lazy-susan bearing is used to couple the stationary base with the rotating base. It is connected through eight nylon screws, where four are fastened to each base. This allows for azimuth-angle degree of freedom control. An additional arm that moves up and down for zenith-angle degree of freedom control, rotates on a support beam that is integrated into the rotating base.

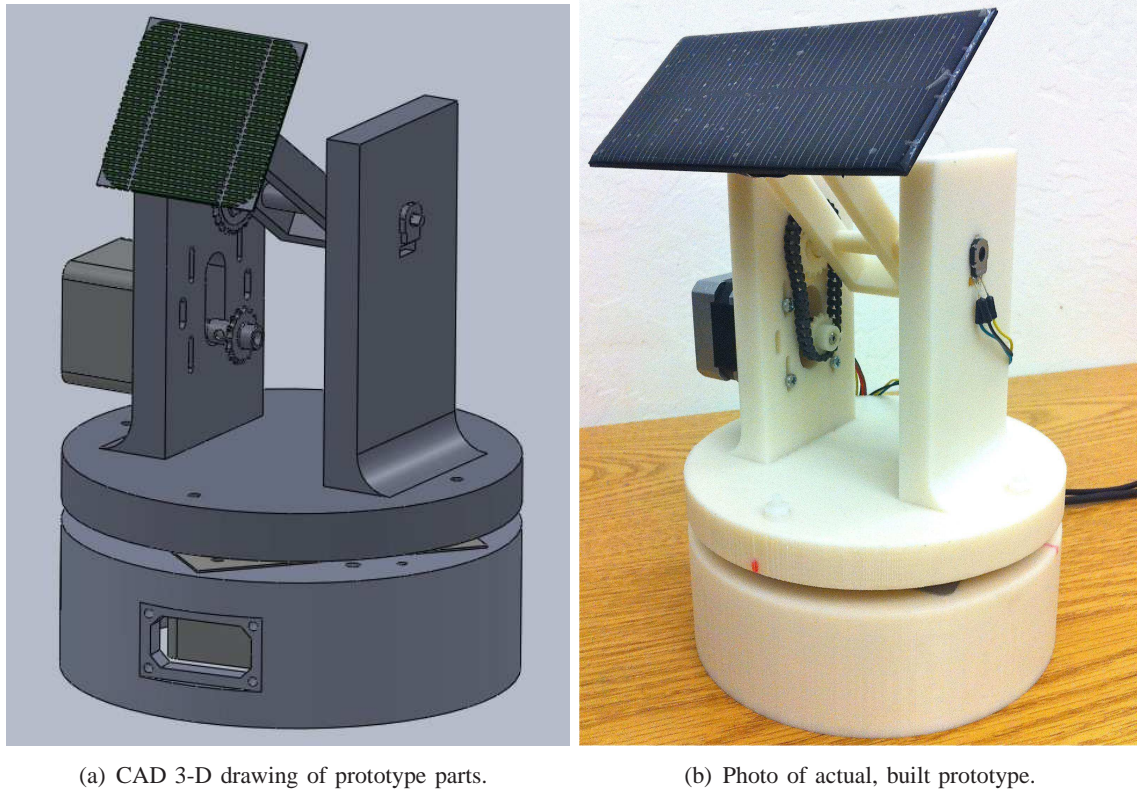

Fig. 3. CAD 3-D drawing of prototype parts, as well as photo of actual, built prototype.

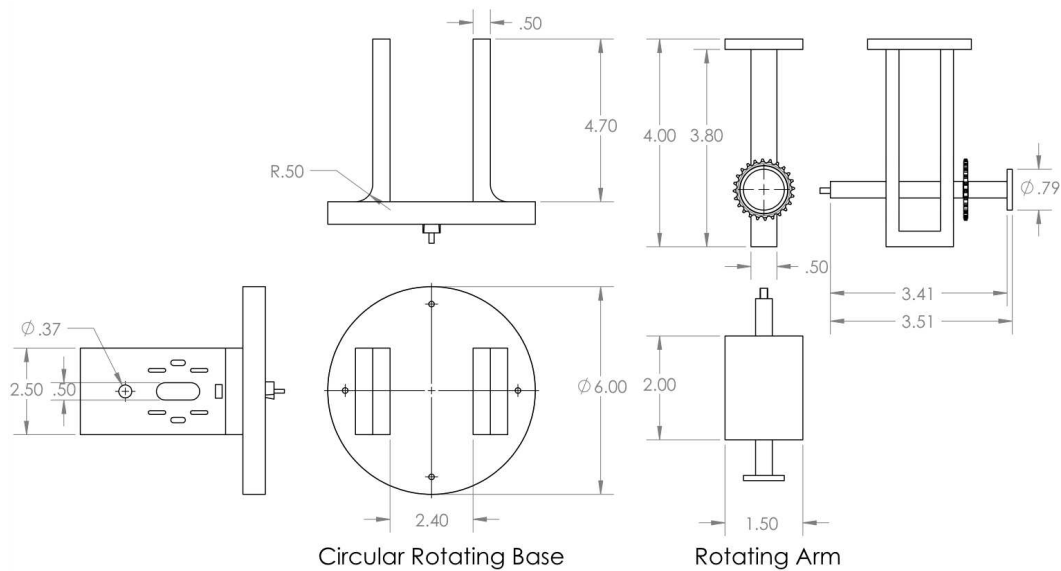

Fig. 4. Mechanical drawing of the collector components. All measurements are in inches.

To determine the state of the system using a sensor, a set of through-hole potentiometers were integrated into the end of the shaft for the rotating arm and at the bottom center of the rotating



Fig. 5. Close-up view of rotating arm that is actuated by plastic chain; the chain is attached to a second smaller sprocket, which is coupled to stepper motor.

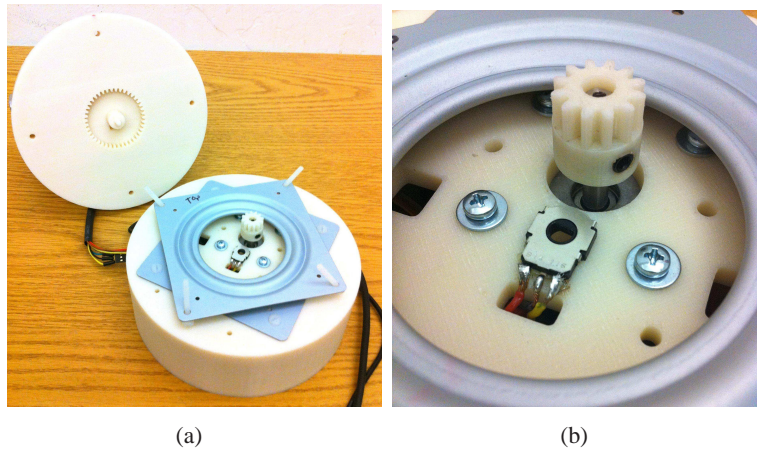

Fig. 6. The stationary base contains a second stepper motor which actuates the rotating base with a small gear coupled to the shaft.

base. The potentiometers have a slotted key design to interface with the shafts. This can be seen in more detail in Figure 7.

2) *Electronics and Embedded System*: The embedded system used for implementation of the hybrid system algorithm for tracking is an *Arduino Uno* with an integrated micro controller. This embedded system enables the user to implement control algorithms quickly and efficiently. Using a package from Mathworks called *ArduinoIO*, the user can integrate an already developed Simulink file for the hybrid system using blocks that are included in the package. Furthermore, by using an add-on called a *Motor Shield*, the Arduino is then capable of motor control, including stepper motor control, using included algorithms and blocks.

The closed loop form of the hardware will take the form as in Figure 8. Using the Simulink block in Figure 9 the tracking method outlined in Section II is implemented and the data obtained from the sensor is used as feedback. The details of the Simulink implementation can be seen in Figure 9. The *ArduinoIO Setup* block initializes the communication with the board via a serial

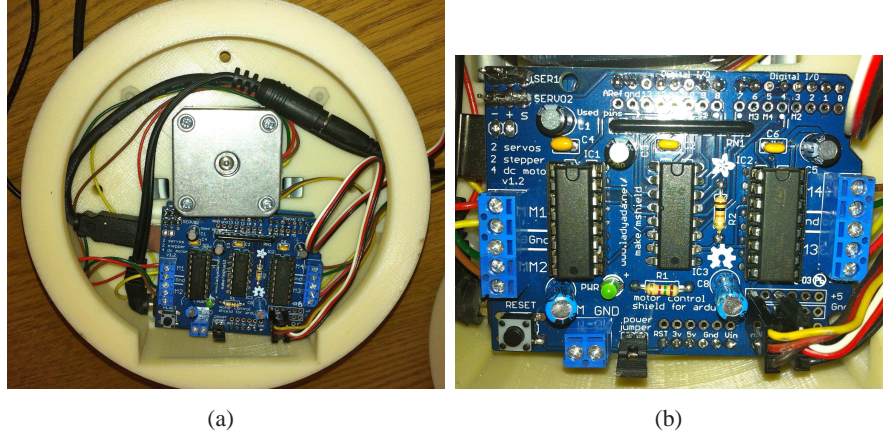

Fig. 7. The stationary base also serves as the housing for the embedded system electronics.

port and the *Real-Time Pacer* block ensures the clock of the simulation time and the board are synced. The preliminary tracking control uses the blocks *Analog Read* to acquire data from the sensors attached to the Arduino interface pins. This input from the sensors is used to determine the error of the system and is passed on to the hybrid controller.

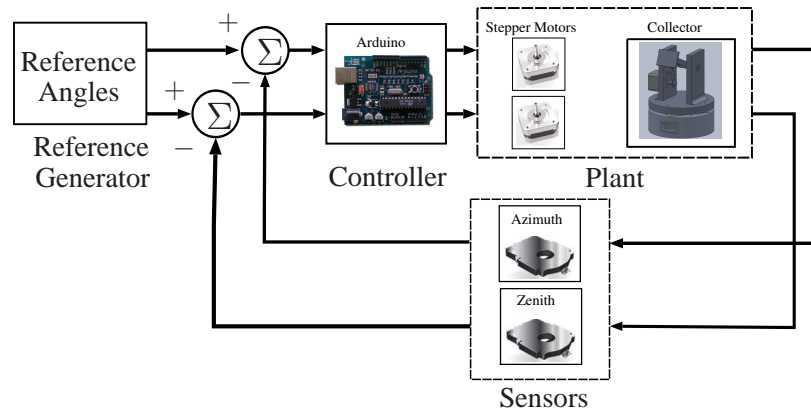

Fig. 8. Closed-loop diagram of hardware, prototype and reference generator.

D. Control Implementation and Experiments (Tasks 3 & 5)

1) *Initial Testing*: Once students have developed the control algorithms with the background and theory learned in the classroom (Task 3), they will implement their algorithms into the embedded system and verify their results. Here we outline the tests that will be performed to verify the performance of the system when interfacing with Simulink. First, the students will verify that the system can track a constant signal. The results obtained for tracking a constant reference signal are summarized in Figure 10 for both the azimuth and zenith angles. Looking at the lower plot for the azimuth angle, the reference is set at 305 degrees. The system begins at the state equal to approximately 175 degrees. The error is equal to the difference between the reference and the initial states. The initial error is approximately 130 degrees. As time progresses the error of the azimuth angle is reduced linearly as it approaches zero and the

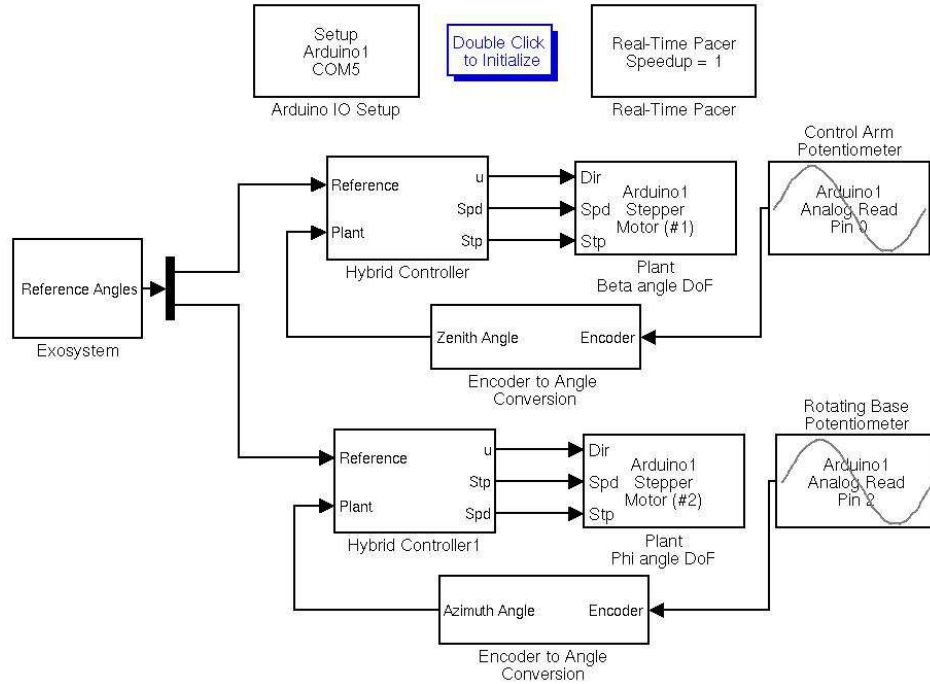

Fig. 9. Simulink interface with Arduino and Sensors. Reference is obtained from exosystem.

state then converges towards the reference. The same conclusion that the state converges to the reference also holds true for the tracking simulation of the zenith angle.

A second test will show the ability of the system to track quick changes in the reference state, similar to a step input. The students will try to recreate results such as in Figure 11. The reference state starts at approximately 90 degrees. A change occurs so that the new reference is 270 degrees. Therefore, the state converges towards the reference. The reference is switched again and at this point, the system is able to identify the optimal direction to turn and moves once more to achieve convergence. This scenario occurs over the course of 15 seconds. Again, the same conclusion can be made for the zenith angle.

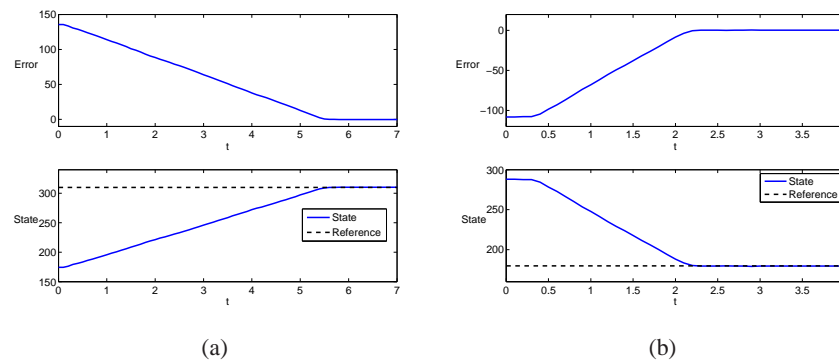

Fig. 10. Error and trajectory plots for the prototype. (a) Azimuth angle. (b) Zenith angle.

In another test, the system is to track a sinusoidal reference that oscillates between 45 degrees

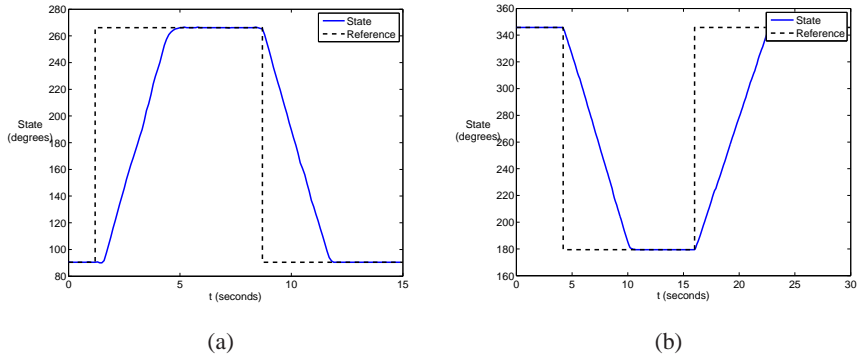

Fig. 11. Response for tracking a step signal. (a) Azimuth angle. (b) Zenith angle.

and 270 degrees. The error is plotted against time, and the results the students will try to achieve can be seen in Figure 12 and 13. The maximum error for the difference in reference and state is ± 0.50 .

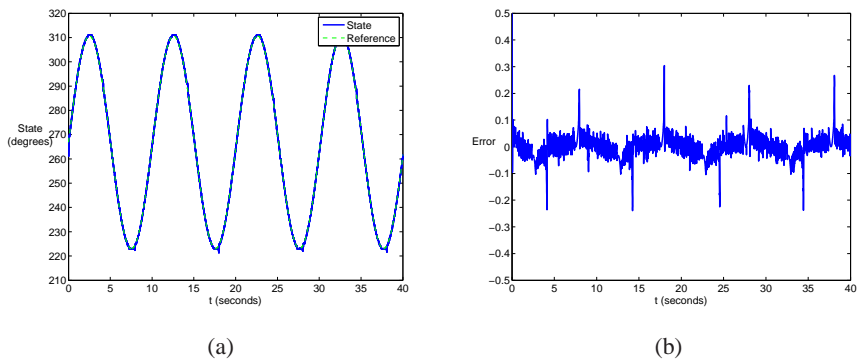

Fig. 12. Azimuth angle. (a) Tracking a sinusoidal reference input oscillating 45 degrees between 270 degrees. (b) Error of the system.

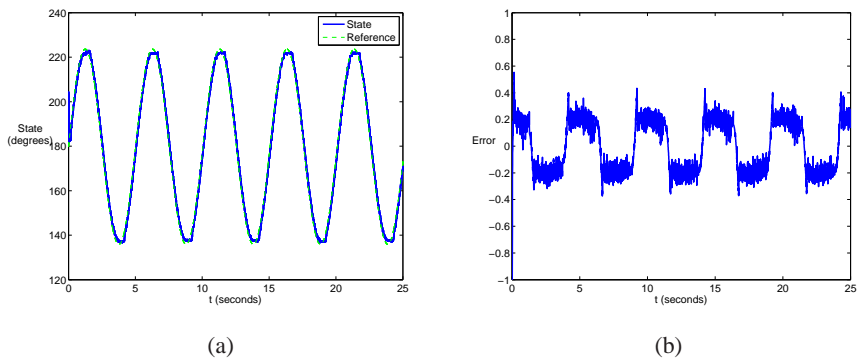

Fig. 13. Zenith angle. (a) Tracking a sinusoidal reference input oscillating 45 degrees between 180 degrees. (b) Error of the system.

2) *Half-day Experimental Test:* Finally, the main task for the students to achieve is for the system to follow the sun for three hours. For our research, the system is subjected to a 12 hour experimental test. The reference position is sampled every hour and a new reference position is obtained for the system to track. The *Exosystem* block in Figure 9 samples a new reference position every hour. The output of this block is the reference trajectory that is passed on to the respective *Hybrid Controller* block for each degree of freedom. This block computes the optimal direction for each degree of system to rotate in and passes the commands to activate the corresponding stepper motor. The response for each degree of freedom with respect to the reference trajectory can be seen in Figures 14. These simulations track the position of the sun from 6:00 A.M. until 6:00 P.M. It can be noted the system successfully tracks the sun's position and performs the optimal rotation to converge to the reference position. This will be similar to what the students will attempt to recreate and show the collector can track the reference signal obtained from the exosystem. For the students' safety, they will not be required to perform this test while the sun is out. Instead, they can gather the data collected from the potentiometer and verify the performance of a system by plotting the reference trajectory and data collected similar to Figures 14.

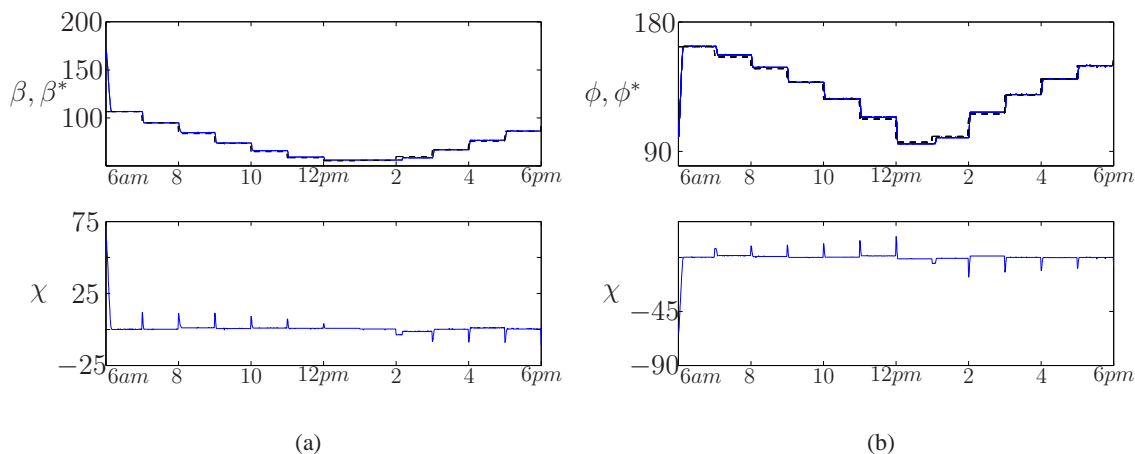

Fig. 14. 12 hour test experiment: collector position in blue and reference trajectory in black dashed line. The error is plotted on bottom graphs.

III. FINAL REMARKS

In this paper, a hands-on kit involving autonomous tracking of the sun in a control system design class was outlined. Students in the course will perform the outlined tasks to apply the theory and background obtained in the classroom and apply it to a real-life problem. The kit has already been tested in a graduate hybrid controls course and is scheduled to be incorporated into undergraduate courses as well. Feedback from the students will be collected and the analysis will be posted at <http://www.u.arizona.edu/~sricardo/index.php?n=Main.Teaching>.

In this paper, the background and information on a solar energy collector was presented, which will be used as the hands-on kit. The students will derive the kinematics of the model to design their control algorithm. A control law will also be obtained by the students. The method used for tracking the position of the sun was outlined in this paper along with some of the associated problems. With this setup, the students will be able to test in a classroom environment their

findings. The two degrees of freedom will allow students to test the control algorithms they derived and verify their effectiveness. The presented series of test that the students will perform will serve as a baseline for the students to use and compare their findings to. Future work will involve incorporating into additional courses, along with expanding from a solar module to a wind collecting module as well.

REFERENCES

- [1] Peter P. Calow. *Blackwells Concise Encyclopedia of Environmental Management*. Malden: Wiley-Blackwell, 1999.
- [2] R. Goebel, R.G. Sanfelice, and A.R. Teel. Hybrid dynamical systems. *IEEE Control Systems Magazine*, pages 28–93, 2009.
- [3] Ari Rabl. *Active Solar Collectors and Their Applications*. New York: Oxford, 1985.
- [4] M. Robles. Hybrid tracking control of impulsive reference signals. Thesis, 2011.
- [5] M. Robles and R. G. Sanfelice. Hybrid controllers for tracking of impulsive reference trajectories: A hybrid exosystem approach. In *Proc. 14th International Conference Hybrid Systems: Control and Computation*, pages 231–240, 2011.
- [6] R. G. Sanfelice, A. R. Teel, and R. Goebel. Supervising a family of hybrid controllers for robust global asymptotic stabilization. In *Proc. 47th IEEE Conference on Decision and Control*, pages 4700–4705, 2008.