

UC Berkeley

Research Reports

Title

Cal Poly Pomona EDAPTS Test Deployment Procurement Documentation Package Version 7.0

Permalink

<https://escholarship.org/uc/item/4s3386kf>

Authors

Jia, Xudong, PhD
Gerfen, Jeff, PhD

Publication Date

2009

CALIFORNIA PATH PROGRAM
INSTITUTE OF TRANSPORTATION STUDIES
UNIVERSITY OF CALIFORNIA, BERKELEY

**Cal Poly Pomona EDAPTS Test
Deployment Procurement Documentation
Package Version 7.0**

**Xudong Jia
Jeff Gerfen**

**California PATH Research Report
UCB-ITS-PRR-2009-5**

This work was performed as part of the California PATH Program of the University of California, in cooperation with the State of California Business, Transportation, and Housing Agency, Department of Transportation, and the United States Department of Transportation, Federal Highway Administration.

The contents of this report reflect the views of the authors who are responsible for the facts and the accuracy of the data presented herein. The contents do not necessarily reflect the official views or policies of the State of California. This report does not constitute a standard, specification, or regulation.

Final Report for 6403

January 2009

ISSN 1055-1425



EDAPTS

Smart Transit System



Task Order 6403 Cal Poly Pomona EDAPTS Test Deployment

Procurement Documentation Package

Version 7.0

Prepared for
California Partners for Advanced Transit and Highways
California Department of Transportation

Prepared by

Xudong Jia, Ph.D., P.E
California State Polytechnic University, Pomona

And

Jeff Gerfen
California Polytechnic State University, San Luis Obispo

Under PATH Contract TO 6403
June 8, 2008

ABSTRACT

This report documents the Bronco Express EDAPTS System procurement process that follows the V-Model. The V-model process led the research team to have a clear understanding of expectations of what the procured system needed to do. It demonstrated a practical procurement and bidding methodology for small/medium transit agencies to acquire their own unique EDAPTS solutions.

The procurement was conducted in two phases: 1) the pre-procurement evaluation and definition processes and 2) the Request for Proposal (RFP) process. In the pre-procurement process, the EDAPTS Operations Guidelines that described the most valued system characteristics through the use of scored operational scenarios was developed. The guidelines helped the research team identify the high-priority operational needs and wants that were eventually incorporated in the RFP document.

The RFP process involved the RFP document development and the selection of a winning contractor. The RFP document development incorporated findings from the pre-procurement process. The selection of the winning contractor was a systematic, unbiased process based on the criteria pre-established in the RFP document.

Keywords: EDAPTS, Procurement Process, System Engineering V-Model, Intelligent Transportation Systems

EXECUTIVE SUMMARY

In the late 1990's, the California Department of Transportation (Caltrans) and the Federal Transit Administration (FTA) embarked on a research program entitled "Efficient Deployment of Advanced Public Transportation Systems" (EDAPTS). The goal was to make lower cost, easily deployed Intelligent Transportation System (ITS) solutions more available to the small transit community.

In 2005, Caltrans and FTA authorized and funded the final EDAPTS research prototype test deployment at the California State Polytechnic University, Pomona, California (Cal Poly Pomona). The Cal Poly Pomona EDAPTS Test Deployment research effort, herein after referred to as the Test Deployment project, provided a final opportunity to evaluate the EDAPTS concepts in a research environment prior to it being fully released for commercial exploitation.

The Test Deployment project used the Systems Engineering V-Model (later referenced as the V-Model) shown in Figure E-1 as the basis for procuring an optimized small transit ITS solution.

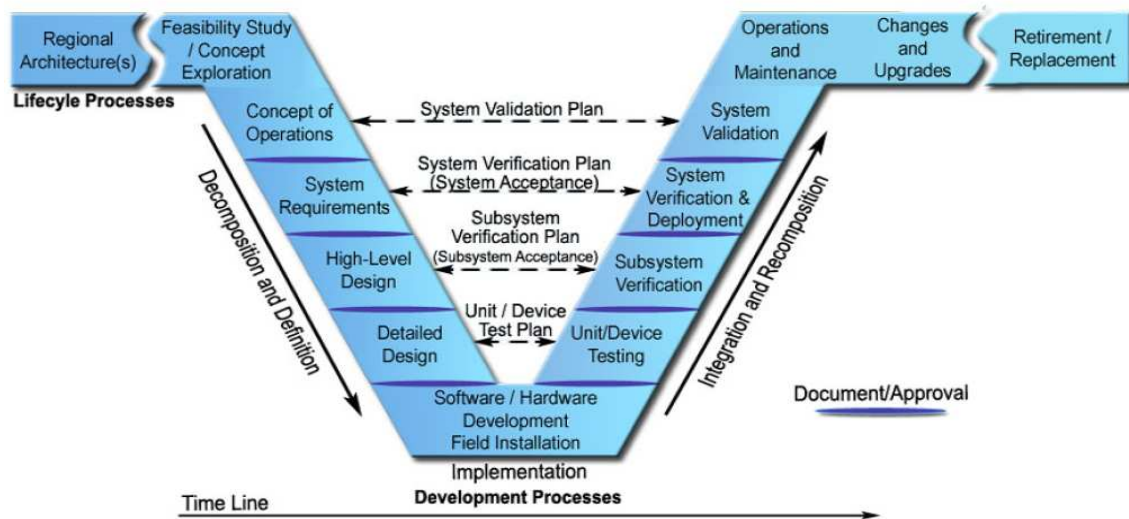

Figure E-1 ITS-Based Systems Engineering V-Model
 (Source: Systems Engineering for Intelligent Transportation Systems, US DOT, 2007)

This report documents the Bronco Express EDAPTS System procurement process that follows the V-Model. The V-model process led the research team to have a clear understanding of expectations of what the procured system needed to do. The procurement was done in two phases: 1) the pre-procurement evaluation and definition processes and 2) the Request for Proposal (RFP) process. In the pre-procurement process, the EDAPTS Operations Guidelines that described the most valued system characteristics through the use of scored operational scenarios was developed. The guidelines helped the research team identify the high-priority operational needs and wants that were eventually incorporated in the RFP document.

The RFP process involved the RFP document development and the selection of a winning contractor. The RFP document development incorporated findings from the pre-procurement process. The selection of the winning contractor was a systematic, unbiased process based on the criteria pre-established in the RFP document.

The Bronco Express RFP was released to the public on February 8, 2008. On March 21, 2008, the research team and the Bronco Express Advisory Panel had a one-day meeting to review all accepted proposals. The evaluation process established a winning vendor and a contract was awarded on April 24, 2008.

In summary, the procurement process for the Bronco Express EDAPTS System used a simplified version of the Systems Engineering process with the V-model as a framework. It demonstrated the following findings:

1) Simplified V-model for the EDAPTS Procurement

The System Engineering process, as outlined by the V-model, called for early stakeholder involvement in a project. The RFP process on the Bronco Express EDAPTS System was successful largely because of this involvement, thanks to the common shared vision among stakeholders it facilitated. This systematic approach ensured that the ITS solution, once acquired, integrated and installed, could be validated using the operational scenarios described in the Operations Guidelines to establish the baseline measurement parameters.

2) EDAPTS Performance Specifications

The research team decided to purchase a commercial solution for the Bronco Express EDAPTS System. In order to ensure seamless interfaces among EDAPTS subsystems, the research team developed a set of Bronco Express EDAPTS Performance Specifications. These performance specifications were critical to the procurement process and are useful during development of the EDAPTS System Verification and Validation Plans for future tasks in the Test Deployment project.

3) Commercially Available Products

Considering the limited resources and ITS experiences available in the Parking and Transportation Services of Cal Poly Pomona, the Bronco Express research team chose to use a commercial vendor approach for the Bronco Express EDAPTS System.

Small transit agencies typically have ITS needs and capabilities similar to those of Bronco Express. Therefore, it seems reasonable that other small transit agencies should consider a similar approach for deploying their EDAPTS ITS solution, as long as the commercially available products and systems meet the operational requirements of the agencies.

4) EDAPTS Business Models

Two separate business models were available when the submitted EDAPTS proposals were reviewed. These two models are:

- The “ITS Ownership” Model. This is the current traditional business model for transit ITS projects. The agency acquires and owns the complete ITS system (hardware and software). It operates and maintains the system independently, though typically it uses the technical support services of the supplier of the ITS system. Technical support service is typically subject to additional, on-going services fees.
- The “ITS Service” Model. This model is an emerging business model for ITS projects. It does not require the transit agency to acquire, own and operate the entire ITS system. The contractor of the ITS system provides the transit agency with core ITS services through a service agreement. Typically this includes services such as vehicle location tracking, schedule adherence, expected next bus arrival time, and dissemination services. However, the transit agency may need to acquire some or all of its own dispatch center equipment, vehicle on-board systems and perhaps even the Roadside Information Display signs in order to get all of the desired functionality from the ITS services.

Researchers Note: The “ITS Service” model proposed for the Bronco Express EDAPTS System is similar to the business model currently used by United States cell phone carriers. Cell phone users do not need to know all the detailed technical requirements for procuring cell phones when they use the phone services, but they do have to buy some equipment and pay an on-going monthly service fee for a set period.

The research team believed the “ITS Ownership” model was better suited to large transit agencies with enhanced financial and technical resources. However, this model seemed less likely to be applicable to similar small or medium sized transit agencies (normally with insufficient financial and technical resources) for installing, operating, and maintaining the ITS system on their own.

The “ITS Service” model seemed better able to leverage the centralized technical resources of the supplier and thus eases the burdens on Bronco Express. Again, based on the Bronco Express situation, similar small or medium sized transit agencies would not need to own the complete ITS system, nor would they have to be immersed in the installation, operation, and maintenance of it. In addition, they do not need to worry about challenging tasks such as maintaining schedule adherence databases or hiring knowledgeable personnel for system troubleshooting and system upgrades. The ITS system contractor handles these kinds of tasks. The transit agency’s only focus is to use the system.

The research team and the proposal review committee selected the “ITS Service” model over the “ITS Ownership” model.

TABLE OF CONTENTS

1.	Project Overview	3
2.	Systems Engineering V-Model	5
3.	Bronco Express EDAPTS Pre-Procurement Process	6
4.	Bronco Express RFP/Bidding process	18
5.	Findings	24
6.	Conclusions	27
7.	References	28
8.	Appendicies	29
Appendix A.	EDAPTS User Features, Operational Needs, and Performance Parameters	29
Appendix B.	EDAPTS Components and Elements as Defined by the High-Level Design.....	29
Appendix C.	EDAPTS Request for Proposal No. 07-014, Cal Poly Pomona, 2007	29
Appendix D..	Conflict of Interest and Confidentiality Statement” Form	29
Appendix E.	Questions to Syncromatics for the Bronco Express EDAPTS System, 2008.	29
Appendix F.	Trip Report of Site Visit at University of California at Riverside, 2008	29
Appendix G.	EDAPTS Contract with Syncromatics, Cal Poly Pomona	29

1. PROJECT OVERVIEW

In the late 1990's, the California Department of Transportation (Caltrans) and the Federal Transit Administration (FTA) embarked on a research program entitled "Efficient Deployment of Advanced Public Transportation Systems" (EDAPTS). The goal was to make lower cost, easily deployed Intelligent Transportation System (ITS) solutions more available to the small transit community.

In 2005, Caltrans and FTA authorized and funded the final EDAPTS research prototype test deployment at the California State Polytechnic University, Pomona, California (Cal Poly Pomona). The Cal Poly Pomona EDAPTS Test Deployment research effort, herein after referred to as the Test Deployment project, provides a final opportunity to evaluate the EDAPTS concepts in a research environment prior to it being fully released for commercial exploitation. This updated EDAPTS implementation, herein after referred to as the Bronco Express EDAPTS System, is currently being designed, installed, operated, and tested on the Cal Poly Pomona campus bus system. Through this test deployment, the potential for commercialization of the EDAPTS concept systems is going through its final assessment. The experience and knowledge gained from this Test Deployment project will assist small transit properties in California and throughout the U.S. in adopting the EDAPTS concepts for their ITS procurements.

The research team worked with the Cal Poly Pomona's Parking and Transportation Services (PTS), the Instructional and Information Technology (I&IT) Division, the Procurement & Support Services, and the EDAPTS Bronco Express Advisory Panel as this prototype system went through the procurement process. The procurement was done in two phases: 1) the pre-procurement evaluation and definition processes and 2) the Request for Proposal (RFP) process. The pre-procurement processes are described Section 3, while the RFP process is provided in Section 4.

The RFP for the Bronco Express EDAPTS System incorporated research findings from the following prior EDAPTS research projects (see Gerfen, 2002; Jia et al, 2007; Gerfen et al, 2007):

- 1) Efficient Deployment of Advanced Public Transportation Systems – Phase 1 and Phase 2; EDAPTS: A Smart Transit System for Small Transit Agencies
- 2) EDAPTS Cost/Benefit Evaluation
- 3) Development of EDAPTS Performance Specifications (hereinafter referred to as the EDAPTS Performance Specifications project).

One of the critical outcomes of the EDAPTS Cost/Benefit Evaluation research project is that the original EDAPTS research system currently operated by San Luis Obispo Transit (SLO Transit) has a calculated benefit-to-cost (B/C) ratio greater than one and is economically viable. This SLO Transit B/C ratio established an economic foundation for

the Bronco Express EDAPTS System and helped justify the Bronco Express RFP development as a technically feasible, economically sound ITS solution.

The Bronco Express RFP was released to the public on February 8, 2008. On March 21, 2008, the research team and the Bronco Express Advisory Panel had a one-day meeting to review all accepted proposals. The review was a systematic, unbiased process that compared all the proposals against pre-established criteria provided in the Bronco Express RFP. The evaluation process established a winning vendor and a contract was awarded on April 24, 2008.

This report documents the Bronco Express EDAPTS System procurement process and is intended to help small/medium transit agencies when used as a guideline in establishing a practical procurement and bidding methodology for acquiring their own unique EDAPTS solutions. The objective is to aid them in selecting the best value vendor(s) for their system. Furthermore, the report describes the benefits of using the well established Systems Engineering V-model during the procurement process. And finally, it describes the most valued lessons the research team learned from the EDAPTS Test Deployment project.

2. SYSTEMS ENGINEERING V-MODEL

The Test Deployment project uses the Systems Engineering V-Model (herein after referred to as the “V-model”) shown in Figure 1 as the basis for procuring an optimized small transit ITS solution. The reasons of choosing the V-model are:

- It is focused on achieving the best possible solution to the problem in the most efficient manner.
- Using the V-model typically leads to improved stakeholder participation, makes the system more adaptable and resilient and delivers a system that is more likely to meet the user’s needs.
- The V-model is already used by many agencies to meet the Federal requirements for ITS projects and provides a common base of understanding between parties.
- The V-model provides a framework for validation and verification of required functionality and operational capabilities.

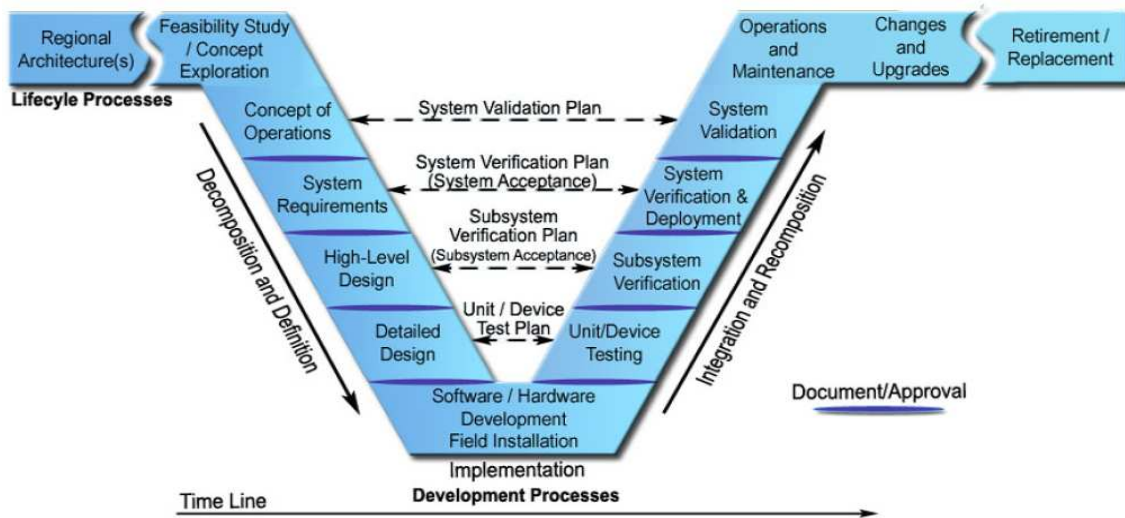

Figure 1 ITS-Based Systems Engineering V-Model

(Source: Systems Engineering for Intelligent Transportation Systems, US DOT, 2007)

3. BRONCO EXPRESS EDAPTS PRE-PROCUREMENT PROCESS

The pre-procurement processes involved the following detailed steps for the Bronco Express EDAPTS System:

Step 1: Incorporating the Bronco Express EDAPTS System into the Master Plan of Cal Poly Pomona

This is equivalent to the step “Regional Architecture(s)” identified in the V-model. However, instead of associating the Bronco Express EDAPTS System with a regional ITS architecture, the University linked the Bronco Express shuttle bus services to its Master Plan and Capital Improvement Programs (Cal Poly Pomona, 2000). Enhancing the shuttle bus services using an ITS solution can improve the operational performance of the shuttle buses, help the University improve its local transportation circulation services for students, faculty and staff, and increase rider confidence in the system.

In the pre-procurement process, the research team considered the University Parking and Transportation Service (PTS) and its Laidlaw transit service provider (First Transit, Inc) as a small public transit agency providing transportation services to the University community. The PTS considered the Bronco Express EDAPTS System as an ITS service improvement project to provide real-time location tracking, schedule monitoring, and arrival time predictions for shuttle bus service.

The research team initially met with the University’s top management and explained the benefits of using the EDAPTS concept to procure the envisioned ITS solution. This group then determined how the Test Deployment project could fit within the overall transportation vision of the University and the Capital Improvements Plan. One positive result of these discussions was a decision by the University to provide some additional funds in support of this project.

The research team found that this discussion step was critical to the successful procurement of the Bronco Express EDAPTS System later on. It helped the University decision-makers come to consensus around the fundamental project scope decisions that were made. As we project this step into the public transit environment, similar benefits should be realized when the University’s Capital Improvement Plan is supplanted by the Regional ITS Architecture or the general plan of a community or city. Doing this step in that environment would clearly put the ITS solution in a broader context and raise awareness of future ITS integration opportunities.

Step 2: Feasibility Study/Concept Exploration

Once the concept of a Bronco Express EDAPTS System was approved by University Administration, the research team conducted an exploratory study on possible alternatives for the system. The focus of the feasibility study was to determine if the Bronco Express EDAPTS System was an economically viable solution for the University.

The exploration process involved site visits to the existing EDAPTS Smart Transit System at San Luis Obispo Transit (SLO Transit) and technical reviews of the documentation related to it. The process helped the research team view the system as an operational ITS solution and one that could form the foundation for the Bronco Express shuttle bus service improvement project.

During this period, there were three primary alternatives considered in the EDAPTS concept exploration process for ITS solutions: 1) the “No Build” approach, 2) the “In-house Build” approach, and 3) the “Commercial Supplier” approach.

The “No Build” alternative would have kept the existing Bronco Express shuttle bus service as it is. For any specific problem or service area, a “No Build” decision indicates that no ITS solution is considered or needed. This may be due to lack of an overwhelming need, lack of an appropriate ITS solution altogether or lack of an affordable ITS solution within the constraints of the procuring agency.

The “In-house Build” alternative would have made use of existing or modified EDAPTS open-source designs or new designs constructed by University personnel to provide the ITS solution.

The “Commercial Supplier” alternative would use private side suppliers to provide the appropriate ITS solution. The solution is procured using the typical Bid and Proposal approach used by the transit industry today.

The EDAPTS twist in this procurement was to perform a systematic trade-off study of needs, solutions (or alternatives), and procurement methodologies that would identify the lowest lifecycle cost system capable of meeting the most important needs of the agency. The trade-off study is frequently demonstrated by calculating its benefit-to-cost (B/C) ratio. If the B/C ratio of the project is greater than one, it is interpreted as an argument supporting a positive recommendation for the project. Since the research team was doing an independent benefit-to-cost study for the SLO Transit EDAPTS System and those results were used to help determine the viability of this project. Our guiding premise was that if the SLO Transit B/C ratio were found to be less than one, it would indicate that the “EDAPTS concept” was potentially not economically feasible for this project and additional analysis and information would have to be considered. Conversely, if the ratio were greater than one, then that would be sufficient to proceed with this research without additional analysis. Since the results of the SLO Transit investigation showed a ratio of greater than one, no further analysis was necessary for this research effort to proceed (see Jia et al, 2007).

Researchers Note: The research findings from the SLO Transit benefit-to-cost study provided a strong recommendation for the use of EDAPTS concepts in procuring ITS technologies. The general small transit business case for using the EDAPTS concepts in procuring lower-cost ITS solutions is enhanced by these results. (see Jia et al, 2007).

Step 3: Concept of Operations

A clear understanding of user needs was critical to the success of the Bronco Express EDAPTS System and to the Cal Poly Pomona EDAPTS Test Deployment project. This step involved 1) establishing an EDAPTS Advisory Panel, 2) identifying problems of the existing shuttle service and assessing the needs for the Bronco Express EDAPTS System, and 3) developing the Bronco Express EDAPTS Operations Guidelines.

1) Bronco Express EDAPTS Advisory Panel

The research team established the Bronco Express EDAPTS Advisory Panel with representation from the University's Parking and Transportation Services (PTS), Instructional and Information Technology (I&IT) Division and the Procurement Services Department. Additional representation was provided by Laidlaw, Caltrans, and Federal Transit Administration (FTA).

The Advisory Panel consisted of the following stakeholder organizations and representatives:

Christi Chisler, Associate Vice President, Student Affairs, Cal Poly Pomona

Glenn Shenker, Director of Parking and Transportation Services (PTS), Cal Poly Pomona

Judy Tillie, PTS, Cal Poly Pomona

Richard Chili Mou, Information System Specialist, Student Affairs Information and Technology Services, Cal Poly Pomona

Susan L. Reese, Projects and Services Manager, Instructional and Information Technology (I&IT), Cal Poly Pomona

Dianne Williams, Laidlaw, First Transit Inc.

Debra A. Garr, Procurement Department, Cal Poly Pomona

Bruce Chapman, EDAPTS Project Manager, Caltrans

Steven Mortensen, Federal Transit Administration

The research team consisted of the following members:

Xudong Jia, EDAPTS Research Project Member, Cal Poly Pomona

Jeff Gerfen, EDAPTS Research Team Project Member, Cal Poly San Luis Obispo

Neil Hockaday, EDAPTS Research Team Project Member, Cal Poly San Luis Obispo

Figure 2 shows a graphical representation of the roles and responsibilities between the different participants in the Bronco Express EDAPTS Test Deployment project. The Advisory Panel acted as the Board of Directors for a small transit agency. Their roles were as follows:

- Establish and prioritize the operations problems, needs and wants of Bronco Express.
- Identify solutions for the identified problems and needs (ITS and non-ITS).
- Review and select the most effective set of ITS solutions for the Bronco Express EDAPTS System.
- Compare the project budget for equipment to estimated market package solution costs.
- Provide input and guidance on system procurement methodology and final authority on make/buy decisions.
- Evaluate, compare and select any third party vendors based on proposals submitted.
- Oversee and monitor the installation, integration, testing and on-going operations and maintenance activities for the Bronco Express EDAPTS System implementation during the project.

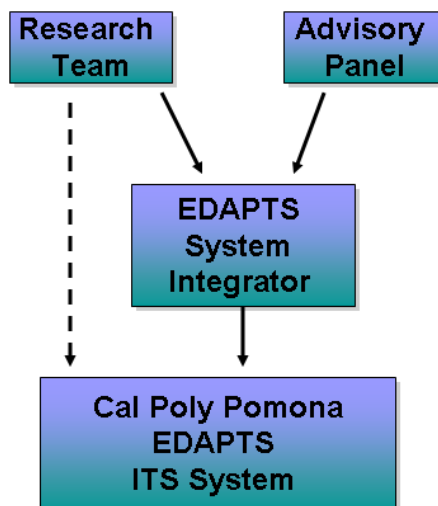

Figure 2 Roles of Advisory Panel in the EDAPTS Test Deployment Project

The research team acted as a facilitator, observer and project manager for the Test Deployment procurement. Their roles were as follows:

- Work with the Advisory Panel to help identify realistic operational needs and to match those needs to innovative EDAPTS ITS solutions.
- Work with the Advisory Panel to embrace and reinforce the EDAPTS concepts (scalable architectures, common interfaces, flexible communications links and low cost designs for operation and maintenance) and develop the EDAPTS procurement document.
- Work with the selected EDAPTS System Integrator or Contractor to deploy the Bronco Express EDAPTS System.
- Evaluate the EDAPTS Systems and subsystems versus the RFP. Help evaluate the bids, assess products procured, and monitor system integration and installation.
- Analyze and document the overall effectiveness of the Bronco Express procurement process.

2) Problems Identification and Needs Assessment

The research team and the Advisory Panel together held a series of workshops to understand how the Bronco Express EDAPTS System should perform and be operated from the views of its various stakeholders.

On July 20, 2006, the research team and the Advisory Panel had a one-day workshop meeting to identify the problems of the existing shuttle bus service and do a “Needs Assessment” on the Bronco Express EDAPTS System. The Advisory Panel provided extensive input on user needs and the envisioned benefits and performance of the future Bronco Express EDAPTS System.

For each identified need, the research team and the Advisory Panel asked and answered the basic who, what, when, where, why, and how questions about the envisioned Bronco Express EDAPTS System from the viewpoint of each stakeholder:

- *Who* are the stakeholders involved?
- *What* are the needed elements/subsystems and the high-level functions?
- *When* will the sequence of technical and project management activities be performed?
- *What* is the geographic and physical extent or service area over which the system is expected to operate?
- *Why* should the system be considered for the Bronco Express shuttle buses?
- *How* will the system be developed, installed, operated, and maintained?

The outcome of the workshop was an interim technical report, the Bronco Express Operations Guidelines, that summarizes these parameters.

On February 6, 2007, the research team and the Advisory Panel held another one-day workshop to review the draft Operations Guidelines and identify the most important Bronco Express EDAPTS System performance requirements and priorities.

3) Bronco Express EDAPTS Operations Guidelines

The final Bronco Express EDAPTS Operations Guidelines document describes the problems and needs of the stakeholders and provides simplified operational scenarios (using descriptive text and graphics) to depict the desired operational characteristics or outcomes for envisioned solutions (see Jia and Gerfen, 2007).

The Operations Guidelines document serves as the concept of operations (ConOps) for the Bronco Express EDAPTS System and takes the place of the more formal ConOps typically envisioned in the V-model. A formal ConOps is typically a major element of any larger procurement and takes considerable resources and time to develop. For small transit EDAPTS concept solutions, it is preferable to use the simple *“What’s the problem and what’s the desired outcome?”* approach of the Operations Guideline document.

The research team developed the operational scenarios of the Bronco Express EDAPTS System by placing the stakeholders to walk through a variety of typical and atypical system use situations. Furthermore, the team documented these operational scenarios in the Operations Guidelines report. Operational scenarios are essentially common language descriptions of how the system might operate and interact with its users. They identify the desired system characteristics of the envisioned system and describe the external interfaces of the system under a given set of circumstances.

The Advisory Panel assigned each operational scenario a priority in order to down-select the most important features of the system. This priority was based on the importance of the system features described in the scenario to the stakeholders. The Panel then selected only the operational scenarios with medium or high priority as deployable elements. These scenarios helped the researchers understand how the system needed to function in daily activities and better characterized the benefits to be realized. It also helped the researchers define any limitations that might have to be accommodated when implemented.

The research team found that operational scenarios played a very important role in the final system design of the Bronco Express EDAPTS System. They bonded the individual parts of the system into a comprehensive whole. They helped stakeholders understand how all the pieces should interact to provide useful operational capabilities. In addition, the scenarios served as the basis for development of the user manual and the acceptance test plans for the system. Finally, the scenarios were useful tools for the research team, and helped define and develop the system verification and validation plans intended to test if the system satisfied user’s needs and expectations.

Step 4: Bronco Express EDAPTS System Requirements

The research team recognized that a clear understanding of system requirements was important to the success of the EDAPTS procurement. Given the needs and the operational characteristics identified in the Operations Guidelines step, the research team defined a set of system performance requirements that describe “what” the Bronco Express EDAPTS System shall do. The performance requirements do not consider “how” the system should be implemented, nor do they specify the ITS technology to be used. The requirements put more focus on what the system should do rather than on how it is to be accomplished.

The performance requirements development process conducted in this step resulted in an interim technical report entitled “EDAPTS User Features, Operational Needs, and Performance Parameters” (see Appendix A). This report documented all the functional and operational requirements at the system level. For example, the report had the on-board system requirements as shown in Table 1.

It is noted from Table 1, that the EDAPTS requirements were represented in terms of user features, operational needs, and performance parameters. They incorporated results of the Operations Guidelines development process (user features and operational needs) with performance requirements. Also the requirements were linked to the subsystems that were to be included in the Bronco Express EDAPTS System.

The research team found that getting stakeholders involved in requirements development is critical. Although stakeholders may not have had detailed knowledge in writing performance requirements statements, they were the experts on their daily operational requirements and held crucial information that needed to be captured in the requirements.

The research team also found that the requirements development process with stakeholders required challenging and thought-provoking brainstorming. However, the performance requirements statements coming out of this process helped to clearly communicate system performance objectives. These objectives satisfied the stakeholders and set the stage to provide clear direction to the future system developers/vendors.

Table 1 Example System Requirements for EDAPTS Test Deployment System

<p><u>4. On-Board System</u></p> <p>Definition: Equipment and software installed in a transit vehicle to perform transit management functions. On-board systems for the Bronco Express EDAPTS system will include a Mobile Data Terminal (MDT) and associated peripherals such as, automatic passenger counter (APC) and driver's emergency button.</p> <p>There are six buses in service every day and two spare buses as backup for the Bronco Express system. Eight on-board systems are required for the EDAPTS system.</p>		
User Features	Operational Needs	Performance Parameters
<p>Mobile Data Terminal (MDT)</p>	<p>To reduce driver workload and improve operational efficiency, a way is needed to automatically collect and display time stamped information on significant operational events.</p>	<p>The MDT shall have the following minimal capabilities to support daily operations:</p> <ul style="list-style-type: none"> ▪ Allows a driver to login the Bronco Express EDAPTS system using their Bronco Express employee ID. The login process and validation shall be completed in less than 2 minutes. ▪ Collects odometer information at the beginning and end of deadhead, at the beginning and end of service (work), and at fuel stops. ▪ Displays actual time clock in a large digit format and removes all other information from the display when the bus reaches a speed of 5 mph or more. Clock shall be synchronized with the clock time shown on dispatch EDAPTS consoles. ▪ Displays important stop information to the driver when a service bus arrives at a stop. At a minimum, this information shall consist of the following items. <ul style="list-style-type: none"> – What the stop ID is – What the current time is – How many minutes remain at the stop before the bus needs to leave for the next stop. Countdown shall be displayed second by second until departure for the stop. ▪ Allows a driver to press a “Boarding” button to manually record passenger count each time a passenger boards.

Table 1 Example System Requirements for EDAPTS Test Deployment System (Cont'd)

User Features	Operational Needs	Performance Parameters
Mobile Data Terminal (MDT)	To reduce driver workload and improve operational efficiency, a way is needed to automatically collect and display time stamped information on significant operational events.	<ul style="list-style-type: none"> ▪ Allows a driver to change shifts within the Bronco Express EDAPTS system. The MDT shall automatically collect all the data related to the shift change and store it into permanent storage. At a minimum, this information shall consist of the following items. <ul style="list-style-type: none"> – Date – Time – Odometer – Route – Location – Drivers involved. ▪ Allows a driver to logout of the Bronco Express EDAPTS system. ▪ Stores bus operational data and transmits it at regular intervals to the central site during normal operations/end of work day/periods/non-use hours/etc. At a minimum, this information shall consist of the following items. <ul style="list-style-type: none"> – Speed – Time stamp – Geo-location (bus location) data. ▪ The MDT shall prompt drivers for odometer reading at the time of fueling. A “Fueling” function should be provided on the MDT menu list.
Automatic Passenger Counter (APC)	To collect ridership information for developing and retuning bus schedules	<p>APC shall be customized to fit into existing shuttle buses.</p> <p>When an APC device is installed on service buses; it should be fully integrated with the MDT on the bus.</p> <p>Passenger counts generated by the APC device should be displayed on the MDT, if budget allows.</p> <p>APC shall collect boarding and alighting data of passengers.</p> <p>Directional sensors are installed above doors of buses, where they detect people coming in or going out of the vehicle.</p>

Table 1 Example System Requirements for EDAPTS Test Deployment System (Cont'd)

User Features	Operational Needs	Performance Parameters
Emergency Button	To provide emergency response measures to improve safety and security of passengers and drivers.	<p>The button shall be resistant to accidental activation, and shall be able to be unobtrusively activated by the driver. When a driver holds the button down for one and a half seconds, a silent emergency signal is sent from the MDT to the dispatch center via the communications link.</p> <p>The Bronco Express EDAPTS system shall implement a preprogrammed emergency response protocol and procedure. Also the system shall have capabilities to handle coded messages between drivers and dispatchers for false alarms.</p> <p>The Bronco Express EDAPTS system shall release the “Emergency Mode” and change back to its normal status after an emergency event is confirmed over.</p>

Step 5: Bronco Express EDAPTS High-Level and Detailed Design

The system design effort involved two levels of design: 1) High-Level Design and 2) Detailed Design at the subsystem level, as suggested by the V-model. The High-Level Design focused on the decomposition of the envisioned Bronco Express EDAPTS System into subsystems and deployable elements. It produced the Bronco Express EDAPTS system architecture that described the subsystems, elements, and interfaces among subsystems. The detailed design process determined how the system would meet the functional, operational and performance needs as defined in the developed performance requirements. It also specified how the subsystems work together to accomplish the overall system goals and objectives.

High-Level Design

The High-level design for the commercially procured Bronco Express EDAPTS System was different from ITS systems that involve in-house system development. It put more emphasis on how to decompose or divide the system into subsystems and ensured that Commercial Off-the-Shelf products can support the decomposed subsystems.

Figure 3 provides the Bronco Express EDAPTS System architecture developed from the high-level design process. Detailed description of the components and elements defined in Figure 3 can be found in Appendix B.

In order to ensure the seamless interfaces among the Bronco Express EDAPTS subsystems, the research team developed an easy-to-use performance-based specification generator tool in the “EDAPTS Performance Specs” project (see Gerfen et al, 2007). The research team used this tool to develop the performance specifications for the Bronco Express EDAPTS subsystems (see Gerfen et al, 2007).

Detailed Design

Since the envisioned solution for the Bronco Express EDAPTS System used products provided by commercial suppliers, it was not possible or necessary to fully document the detailed design or do a low-level decomposition. The low-level decomposition was left to the system integrator or vendor contracted for the installation.

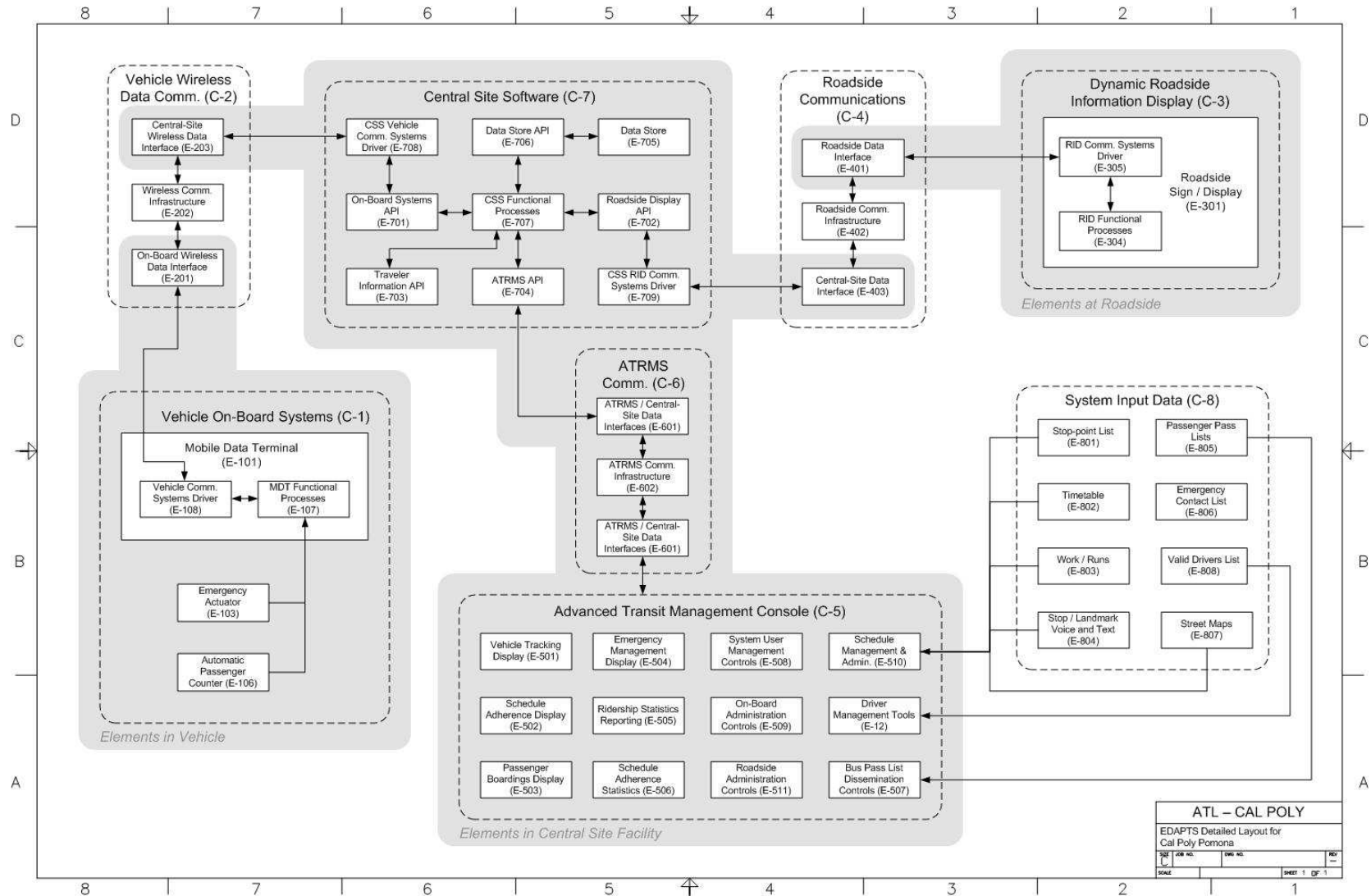

Figure 3 High-Level Design of the Bronco Express EDAPTS System

4. BRONCO EXPRESS RFP/BIDDING PROCESS

Following the V-model process and the Operations Guidelines document, the Bronco Express EDAPTS System RFP effort was started after the Bronco Express Advisory Panel and the EDAPTS research team had a complete and common understanding of the final system architecture and its desired impact on each stakeholder.

Using the EDAPTS performance-based specifications, system requirements and high-level design structure as inputs, the research team developed the RFP for the Test Deployment project (see Appendix C). The RFP document was the basic bidding document released to potential vendors. Figure 4 shows the relationships between the Operations Guidelines, the System Design and Performance Specifications, and the RFP processes.

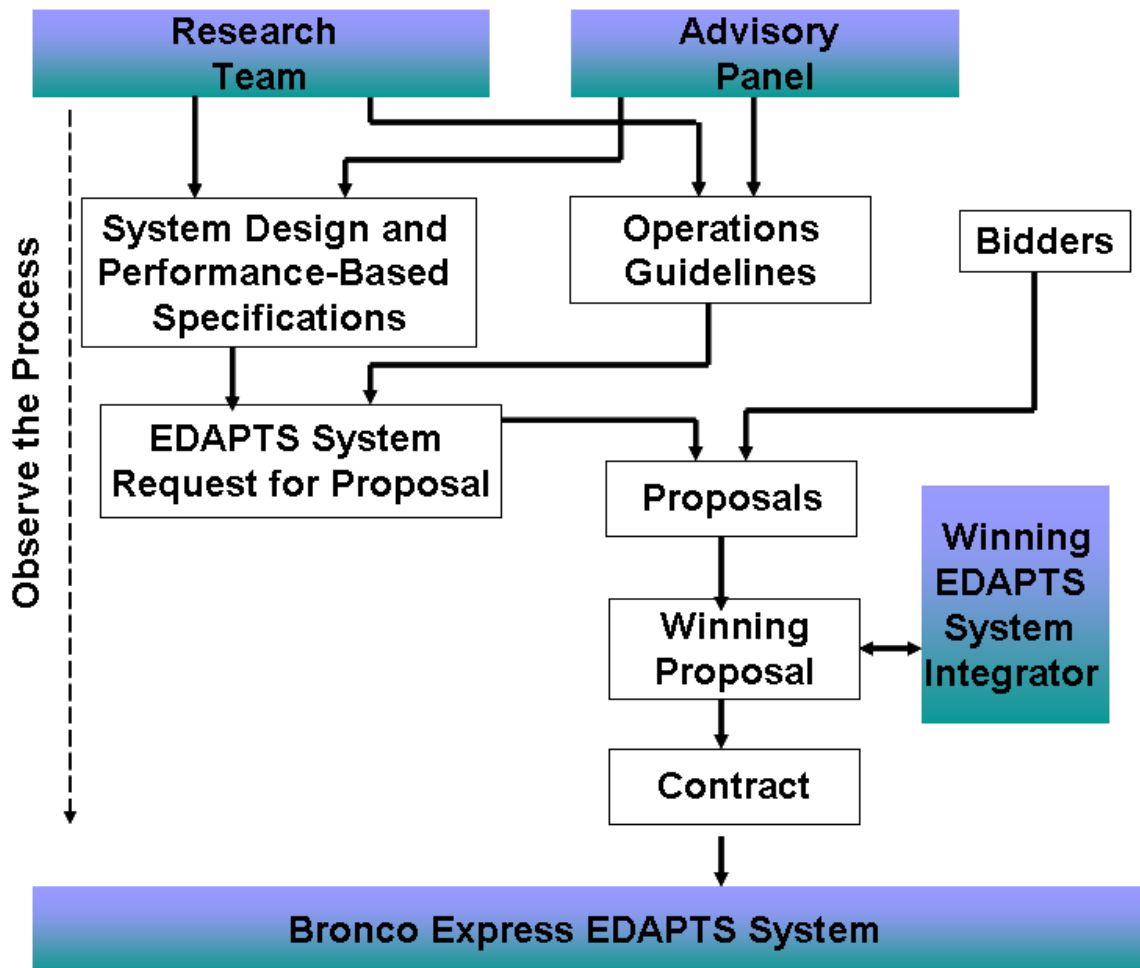

Figure 4 Relationships of Operations Guidelines, System Design, and RFP Procurement Process

1) EDAPTS RFP Preparation

The research team worked with the University's Parking and Transportation Services and the Procurement & Support Services to prepare and write the RFP document. The collaborative development effort ensured that the document not only reflected the most desirable user features, operational requirements, and performance specifications for the Bronco Express EDAPTS System, but it also complied with the University's policies and procedures. The early involvement of PTS and Procurement & Support Services staff in the process allowed them to understand how the Bronco Express EDAPTS System will help stakeholders. They were intimately involved in deciding which subsystems were to be purchased and how the system would be operated and managed.

The RFP document provided detailed insight into the intended usage of the system, allowing potential contractors to better focus their responses. The creativity and innovation that individual contractors choose to build into their proposals were used in judging the proposals.

The RFP document also specified the work schedule, milestones, deliverables, and due dates for the basic system. Also it required the contractors to provide an optional maintenance service agreement. The purpose of the requested maintenance service agreements was to ensure long-term operation of the system after it is delivered to the University.

The research team used the University's standard review and comment process in developing the RFP document. After the preliminary document was framed, it was reviewed and commented on by the EDAPTS Advisory Panel. The research team then modified and revised the document based on the comments and recommendations received from the reviewers.

2) EDAPTS Contractor Identification and RFP Responses

The approved RFP document was advertised on the official procurement web site of Cal Poly Pomona. Also the research team sent the document to known suppliers of this kind of equipment. The objective of this distribution was to have at least three proposals submitted for the Bronco Express EDAPTS System.

Seventy-one (71) EDAPTS potential contractors were identified for this project and the RFP was sent to all of them. Five contractors responded with proposals. Four proposals met the RFP requirements and were accepted for further evaluation. The fifth proposal did not meet the requirements and was rejected due to late submittal of the bid package.

3) EDAPTS Proposal Evaluation

The proposal review committee, which had been formed prior to publication of the RFP, evaluated the four accepted proposals. The committee consisted of the following members:

Christi Chisler, Associate Vice President, Student Affairs, Cal Poly Pomona

Glenn Shenker, Director of Parking and Transportation Services (PTS), Cal Poly Pomona

Susan L. Reese, Projects and Services Manager, Instructional and Information Technology (I&IT), Cal Poly Pomona

Debra A. Garr, Procurement Department, Cal Poly Pomona

Bruce Chapman, EDAPTS Project Manager, Caltrans

Steven Mortensen, Federal Transit Administration

Xudong Jia, EDAPTS Research Project Manager, Cal Poly Pomona

Jeff Gerfen, EDAPTS Research Team Project Member, Cal Poly San Luis Obispo

All review committee members signed a “Conflict of Interest and Confidentiality Statement” form, as shown in Appendix D, prior to accessing the confidential proposals submitted. The Test Deployment project also used this form to ensure that the members had no personal or financial interest in any of the companies being considered and had no present or past employment activity that would be incompatible with their participation in the solicitation review and contractor selection process. In doing so, the University was assured that the review members were able to give full, fair, and impartial consideration to all proposals.

The proposal review committee compared the four proposals using the pre-established evaluation criteria in the RFP (see Table 2) and had the following findings from the four proposals.

Table 2 EDAPTS Evaluation Criteria

Criteria	Point Value
<p>Vehicle On-Board System and Vehicle Wireless Data Communications System</p> <ul style="list-style-type: none"> - Does the system deliver core features? - Are desired options, e.g. APC, available? - Are EDAPTS performance specifications, including the EDAPTS data formatting standard, met? - Is the proposed wireless data communications system suitable for the Cal Poly Pomona environment? 	15
<p>Advanced Transit Management System (ATRMS) and Central Site Software (CSS) Server</p> <ul style="list-style-type: none"> - Does the system deliver core features? - Are desired options available? - Are EDAPTS performance specifications, including the EDAPTS data formatting standard, met? - Do the roadside information displays deliver core features? - Are the roadside information displays aesthetically pleasing? - Are the roadside information displays solar powered? - Is the roadside information display wireless data communications system suitable for the Cal Poly Pomona environment? 	15
<p>Open-Source software</p> <ul style="list-style-type: none"> - Is the planned software package open-source? - Is the data formatting between the interfaces of all components defined and available to Cal Poly Pomona? - Are all Application Programmer Interfaces (APIs) defined? 	5
<p>No Software Licensing Fee</p> <ul style="list-style-type: none"> - Does the proposed system have any annual software license fees? 	5

Table 2 EDAPTS Evaluation Criteria (Cont'd)

Criteria	Point Value
<p>Installation & Testing</p> <ul style="list-style-type: none"> - How long is the planned system installation to take and will it be disruptive to Cal Poly Pomona operations? - Will the installation be completed solely by the vendor or will Cal Poly Pomona have responsibilities? - Are customer acceptance test procedures to be provided for the on-board systems, roadside information displays, ATRMS, and central-site software? 	10
<p>Warranty and Service Contracts</p> <ul style="list-style-type: none"> - How long is the warranty for the vehicle on-board systems & supporting data communications system? - How long is the warranty for the ATRMS and central site software? - How long is the warranty for roadside information displays & supporting data communications system? - What is the annual cost for service contracts? <p>Are there any other recurring costs required for system operation? How much are they?</p>	10
<p>References and Experience</p> <ul style="list-style-type: none"> - How much experience does the vendor have with similar jobs? - Does the vendor have any other relevant experience? - Does the vendor have any experience with open-source systems? - Are the vendor's references good? - Are the references credible? 	10
<p>Cost</p> <p>The lowest cost proposal receives the maximum points. Each higher priced proposal will be scored as follows:</p> <p>Proposal amount divided by low proposal amount = cost factor. 30 points divided by cost factor = scored points. Fractional points are rounded up.</p> <p>EXAMPLE: Bid "A" was low at \$10,000 and received 30 points. Bid "B" was next lowest at \$11,000. Bid "B" when divided by Bid "A" equals a cost factor of 1.1. 30 points divided by 1.1 equals the point score of 27.3. Fractional rounding yields a point score of 27.</p>	30

All proposals were individually reviewed and informally scored by each committee member. The committee then discussed each proposal and assigned a consensus score for each category and for each proposal. Based on these scores, the four accepted proposals were ranked as shown below.

<u>Contractor</u>	<u>Evaluation Points</u>
Vendor 1	52
Vendor 2	47
Vendor 3	40
Vendor 4	80 (best score)

Syncromatics Corporation had the best value score and was selected as the tentative winner.

4) EDAPTS Contract Negotiation/Awarding

Following the recommendations of the proposal review committee, the University made a formal notification of the intent to award a contract to Syncromatics for the Bronco Express EDAPTS System. This award was contingent upon the outcome of a performance demonstration and continued availability of funding. Along with the letter of intent, the proposal review committee also forwarded a list of questions that needed to be addressed during the demonstration session. These questions were designed to help the committee determine if the system met their stated needs and if it would be consistent with the intended Bronco Express usage. These questions are provided in Appendix E.

The proposal review committee members also made a comprehensive check of references listed in the Syncromatics proposal. They talked to the current customers to get a better understanding of the Syncromatics systems currently installed and operated in other locations. Some committee members made a special site visit trip to the University of California at Riverside (UCR) and observed the Syncromatics system installed for the UCR shuttle bus system. The resulting opinion of the members was that the Syncromatics system met the needs for the Bronco Express EDAPTS System. The trip report is provided in Appendix F.

The University signed the official contract with Syncromatics on April 24, 2008. The contract is provided in Appendix G.

Researcher Note: With the issuance of a contract, the logical conclusion of the procurement segment has been reached and the EDAPTS Test Deployment project now moves forward to the next segment of the project, Field Installation and Test segment). At this time, it should be noted that open issues relating to lack of ADA compliance of the dynamic roadside signs remain to be resolved during the installation and Test segment. These open issues will be addressed during the report on those steps rather than hold this deliverable open and delay submittal of this document.

5. FINDINGS

The procurement process for the Bronco Express EDAPTS System used a simplified version of the Systems Engineering process with the V-model as a framework. The advantages of this approach is that it allowed: 1) stakeholders to actively participate in the project from the beginning, 2) identification of the highest priority EDAPTS subsystems in the High-Level design step, 3) development of relevant performance specifications for the selected EDAPTS subsystems, 4) facilitation of make/buy decisions for the EDAPTS System, and 5) selection of a qualified contractor for the integration and installation of the system.

The research team has the following findings regarding the procurement process we used:

1) Use of Simplified V-model for EDAPTS Procurements

The System Engineering process, as outlined by the V-model, calls for early stakeholder involvement in a project. The RFP process on the Bronco Express EDAPTS System was successful largely because of this involvement, thanks to the common shared vision among stakeholders it facilitated. This systematic approach ensured that the ITS solution, once acquired, integrated and installed, could be validated using the operational scenarios described in the Operations Guidelines to establish the baseline measurement parameters.

It is recommended that the V-model based procurement process be used by small transit agencies to help identify needs, define important user features, operational needs, develop appropriate performance specifications and write a successful RFP document.

2) EDAPTS Performance Specifications

The research team decided to purchase a commercial solution for the Bronco Express EDAPTS System. In order to ensure seamless interfaces among EDAPTS subsystems, the research team developed a set of Bronco Express EDAPTS Performance Specifications and included a specialized EDAPTS data formatting standard developed in the “EDAPTS Performance Specifications” project (see Gerfen et al, 2007). These performance specifications were critical to the procurement process and are useful during development of the EDAPTS System Verification and Validation Plans for future tasks in the Test Deployment project.

The Bronco Express EDAPTS Performance Specifications and the specified EDAPTS data formatting standards were included in the RFP document. It is anticipated that these specifications and standards considered and guide the winning contractor when it installs the system for the University. The research team will verify and validate the Bronco Express EDAPTS system in future tasks and assess the specific areas of conformance or deficiency of the installed system to the RFP specifications and standards.

3) Use of Commercially Available Products

Understanding the operational needs and performance requirements of the Bronco Express EDAPTS System and assessing the resources and capabilities of the procuring agency is critical to the determination of procuring commercial products or conducting in-house development for the solution. Considering the limited resources and ITS experiences available in the PTS, the Bronco Express Advisory Panel chose to use a commercial vendor approach for the Bronco Express EDAPTS System. The benefits to PTS were:

- Products and systems are typically more likely to have been proven in the marketplace.
- Costs for developing and upgrading products/systems are amortized over a larger population of procuring agencies.
- Products and systems can often be observed in operation at other locations before the actual decision is made on procurement of the system.

Small transit agencies typically have ITS needs and capabilities similar to those of Bronco Express. Therefore, it seems reasonable that other small transit agencies should consider a similar approach for deploying their EDAPTS ITS solution, as long as the commercially available products and systems meet the operational requirements of the agencies.

4) EDAPTS Business Models

The research team and the Advisory Panel were faced with two separate business models when they reviewed the submitted EDAPTS proposals. These two models are:

- The “ITS Ownership” Model. This is the current traditional business model for transit ITS projects. The agency acquires and owns the complete ITS system (hardware and software). It operates and maintains the system independently, though typically it uses the technical support services of the supplier of the ITS system. Technical support service is typically subject to additional, on-going services fees.
- The “ITS Service” Model. This model is an emerging business model for ITS projects. It does not require the transit agency to acquire, own and operate the entire ITS system. The contractor of the ITS system provides the transit agency with core ITS services through a service agreement. Typically this includes services such as vehicle location tracking, schedule adherence, expected next bus arrival time, and dissemination services. However, the transit agency may need to acquire some or all of its own dispatch center equipment, vehicle on-board systems and perhaps even the Roadside Information Display signs in order to get all of the desired functionality from the ITS services.

Researchers Note: The “ITS Service” model proposed for the Bronco Express EDAPTS System is similar to the business model currently used by United States cell phone carriers. Cell phone users do not need to know all the detailed technical requirements for procuring cell phones when they use the phone services, but they do have to buy some equipment and pay an on-going monthly service fee for a set period.

For Bronco Express, the Advisory Panel believed the “ITS Ownership” model was better suited to large transit agencies, where enhanced financial and technical resources are more likely to be available. However, based on the comparative dollar value of the bids received, this model seemed less likely to be applicable to similar small or medium sized transit agencies, since they often lack the available financial and technical resources for installing, operating, and maintaining the ITS system on their own.

The “ITS Service” model seemed better able to leverage the centralized technical resources of the supplier and thus eases the burdens on Bronco Express. Again, based on the Bronco Express situation, similar small or medium sized transit agencies would not need to own the complete ITS system, nor would they have to be immersed in the installation, operation, and maintenance of it. In addition, they do not need to worry about challenging tasks such as maintaining schedule adherence databases or hiring knowledgeable personnel for system troubleshooting and system upgrades. The ITS system contractor handles these kinds of tasks. The transit agency’s only focus is to use the system.

Three of the four proposals submitted for the Bronco Express EDAPTS System were based on the use of the “ITS Ownership” model. The proposed deployment costs of these Bronco Express EDAPTS System’s were in the range of \$250,000 to \$600,000 (capital costs) plus \$30,000 to \$60,000/year required for additional Operational and Maintenance services for the eight bus system, depending on vendor and options exercised.

The remaining proposal used the “ITS Service” model for the project. It required the University to acquire all hardware for the vehicle on-board systems as well as Personal Computers for the dispatch center. The required purchased equipment included MDTs, APCs, GPS-based AVL subsystems and the Roadside Information Display signs,. With these acquired devices, the University uses Web-based services to receive information such as vehicle location tracking, schedule adherence, expected next bus arrival time, and real-time status reporting from Syncromatics. The University did not need to operate or maintain the performance databases for the Bronco Express EDAPTS System but can download and archive on University equipment the operational data for analysis and historical reporting purposes. The cost was in the range of \$65,000 – \$70,000 (capital costs) plus \$15,000/year (service lease costs) for the eight (8) bus system, depending on options exercised.

The research team and the proposal review committee selected the “ITS Service” model over the “ITS Ownership” model.

6. CONCLUSIONS

The Bronco Express EDAPTS System was procured using two major work breakouts: 1) The pre-procurement process and 2) The RFP process. The Systems Engineering V-model based procurement facilitated early stakeholder involvement in the process.

In the pre-procurement process, the Advisory Panel, stakeholders and project team used the EDAPTS Operations Guidelines to understand the overall operational characteristics of the desired Bronco Express EDAPTS System. The guidelines helped them identify the high-priority operational needs and wants that were eventually incorporated in the RFP document. The Systems Engineering V-model process led to clear expectations and articulation of what the procured system needed to do.

The RFP process involved the RFP document development and the selection of a winning contractor. The RFP document development incorporated findings from the pre-procurement process. The selection of the winning contractor was a systematic, unbiased process based on the criteria pre-established in the RFP document.

7. REFERENCES

- 1) Cal Poly Pomona, Master Plan, 2000.
http://www.csupomona.edu/~fpm/planning/master_plan/index.html
- 2) Caltrans System Engineering Process Checklist
- 3) Caltrans System Engineering Guide Book for ITS
- 4) Xudong Jia, Edward Sullivan, Cornelius Nuworsoo, and Neil Hockaday. “EDAPTS Cost/Benefit Evaluation.” Technical Report, California PATH and Caltrans, 2007.
- 5) Xudong Jia, Jeff Gerfen, Neil Hockaday. “Task Order 6403: Cal Poly Pomona EDAPTS Test Deployment Operations Description, Version 6.0.”, Technical Report, California PATH and Caltrans, 2007.
- 6) Jeff Gerfen. “Efficient Deployment of Advanced Public Transportation Systems – Phase 1 & 2 EDAPTS: A Smart Transit System for Small Transit Agencies.” 2003.
- 7) Alan Hansen and James Colyar, Guidance on Using the Systems Engineering Process in ITS Projects, FHWA Arizona Division Office, August 2002
- 8) US Department of Transportation. “System Engineering for Intelligent Transportation Systems: An Introduction for Transportation Professionals.” January 2007.

8. APPENDICIES

- Appendix A. EDAPTS User Features, Operational Needs, and Performance Parameters
- Appendix B. EDAPTS Components and Elements as Defined by the High-Level Design
- Appendix C. EDAPTS Request for Proposal No. 07-014, Cal Poly Pomona, 2007
- Appendix D... Conflict of Interest and Confidentiality Statement” Form
- Appendix E. Questions to Syncromatics for the Bronco Express EDAPTS System, 2008.
- Appendix F. Trip Report of Site Visit at University of California at Riverside, 2008
- Appendix G. EDAPTS Contract with Syncromatics, Cal Poly Pomona



EDAPTS

Smart Transit System



Task Order 6403

Cal Poly Pomona

EDAPTS Test Deployment

User Features, Operational Needs and Performance Parameters

Version 1.0

Prepared for
California Partners for Advanced Transit and Highways
California Department of Transportation

Prepared by
California State Polytechnic University, Pomona
California Polytechnic State University, San Luis Obispo

Under PATH Contract TO 6403
June 8, 2007

User Features	Operational Needs	Performance Parameters
<p>1. <u>Dynamic Roadside Information Display</u></p> <p>An electronic, remotely controlled display that presents information regarding estimated time of arrival of buses to passengers waiting at bus stops. These displays typically provide "real-time" information based upon bus progress along route.</p>		
<p>Dynamic real-time transit arrival sign</p>	<p>Real-time arrival signs shall be installed at bus stops served by Route A, B, and C.</p>	<p>All the signs shall meet ADA accessibility requirements. All the signs shall be easily maintained.</p> <p>All sign maintenance procedures and maintenance intervals shall be documented within the EDAPTS system maintenance manual.</p> <p>All installed parts shall meet FCC guidelines and licensing as appropriate. They shall meet MIL-STD-461 tolerances for radiated emissions.</p> <p>All exposed materials of signs shall be corrosion resistant.</p> <p>Electronic equipment associated with signs remains from damage and are protected from moisture, dust, dirt, and corrosion.</p> <p>All parts in signs shall be readily accessible for inspection and maintenance.</p> <p>Signs shall be energy efficient.</p>
<p>Sign design</p>	<p>Sign design shall consider two types of signs (large format and small format).</p>	<p>Signs shall be made and installed to conform to the Signage Design Guidelines of Cal Poly Pomona. The Guidelines can be found at http://www.csupomona.edu/~fpm/Planning/procedures_guidelines/sign_design_manual.pdf.</p> <p>Signs shall be easily cleaned.</p>

User Features	Operational Needs	Performance Parameters
		<p>Large format signs shall have a panel to display at least two rows of characters; each row shall contain at least 15 characters.</p> <p>Small format signs shall have a panel to display at least 5 characters. Characters in the panel shall display for 3 seconds and move from right to left character by character.</p> <p>Characters must be legible under all light conditions at a distance of 5-10 ft.</p>
Large format sign locations	<p><u>Three</u> large format signs are installed at Village, Building 1, and CLA Building time point stops on Route A and B.</p>	
Small format sign locations	<p><u>Twenty-Eight (28)</u> small signs are installed at non-time point stops on Route A, as well as all stops on Route B and C.</p>	
Sign message, small format signs	<p>At single route, non-overlapping stops a single message shall be displayed as:</p> <p>“Bus Here in XX Min”</p>	<p>Color and size of single messages shall be designed to meet ADA requirements and the University’s Graphic Standards. The Graphic Standards Manual can be found at http://www.csupomona.edu/~publicaffairs/graphics/</p> <p>Message shall be held static for approximately 2 seconds and then updated with new, current information from the EDAPTS vehicle location system</p>

User Features	Operational Needs	Performance Parameters
		(i.e. Bus Here in 10 min -> Bus Here in 9 min -> Bus Here in 8 min -> etc.)
Sign message, large format signs for overlapping stops	<p>At overlapping stops on Routes A and B, the sequence of messages, displayed below, shall be repeated:</p> <p>“Rt A Here in XX Min” “Rt B Here in XX Min”</p> <p>At overlapping stops of Routes B and C. the sequence of messages, displayed below, shall be repeated:</p> <p>“Rt B Here in XX Min” “Rt C Here in XX Min”</p>	Message shall be held static for approximately 7 seconds and then updated with new, current information from the EDAPTS vehicle location system on the next route served at the sign location (i.e. Rt A Here in XX Min> Rt B Here in XX min > Rt A Here in XX min > Rt B Here in XX min > etc.)..
Out of Service message, non-overlapping route signs	<p>When <u>all</u> the buses on a specific route are temporally out of service, all signs on that route shall display the following message:</p> <p>“Out of Service”</p>	Message shall be held static until service is back. When the service is back, message will be updated with new, current information from the EDAPTS vehicle location system (i.e. Out of Service > Rt A Here in XX Min > Rt A Here in XX Min -> etc.).
Out of Service message, overlapping route signs	<p>At overlapping signs serving Route A and B, a sequence of messages below shall be displayed when all Route B buses are not operating:</p> <p>“Rt A Here in XX Min” “Rt B Out of Service”</p> <p>At overlapping signs serving Route B and C, a sequence of messages below shall be displayed when all Route B buses are not operating:</p>	Message shall be held static until service is back. When the service is back, message will be updated with new, current information from the EDAPTS vehicle location system (i.e. Out of Service > Rt A Here in XX Min > Rt B Here in XX Min -> Rt A Here in XX Min -> Rt B Here in XX Min -> etc.).

User Features	Operational Needs	Performance Parameters
	<p>"Rt B Out of Service"</p> <p>"Rt C Here in XX Min"</p>	
Public service announcements	All the large signs shall be able to display public service announcements, system status, or emergency information	
Power source, small format signs	Small signs shall be powered by replaceable batteries.	<p>Batteries installed in small signs shall be Industry-standard batteries and are easily exchanged. In order to reduce maintenance costs, rechargeable batteries are desirable.</p> <p>Batteries shall last at least six months under specified operation duty cycle.</p> <p>Batteries shall operate within the temperature of -20°C to 45 °C and support the display of 1000 messages per day.</p> <p>Small signs and batteries shall be enclosed in a heavy-duty enclosure that is vandal and weather resistant.</p>
Power source, large format signs	Large signs shall be solar-powered or powered by wires. Solar powered signs are preferable where no existing AC power source exists at the installation site . When wired signs are considered, their installation costs shall include all the costs associated with getting AC to sign sites and connecting the signs to the AC supply, including any permits, inspections, etc.	<p>When solar powered signs are considered, they shall have the following parameters:</p> <ul style="list-style-type: none"> ▪ Capable of operating for up to 20 days of inclement weather. ▪ Enclosed in a heavy-duty enclosure that is vandal and weather resistant. <p>When wired signs are considered, they shall have the following parameters:</p>

User Features	Operational Needs	Performance Parameters
		<ul style="list-style-type: none"> ▪ Signs and batteries shall be enclosed in a heavy-duty enclosure that is vandal and weather resistant. ▪ Power used by signs shall be adapted to 120 VAC / 60 Hz.
Protection, primary power source	All power connections shall be protected by fuses or breakers.	
Sign post locations	Sign posts shall be placed at the same locations as existing ones.	<p>Each post shall be designed to meet the University's standards and guidelines. The standards and guidelines can be found at http://www.csupomona.edu/~fpm/Planning/procedures_guidelines/sign_design_manual.pdf.</p> <p>The height of posts shall be 8 ft according to the University's policy.</p>
Mounting supports and foundation	Sign posts shall be capable of handling weight/wind load requirements with the displays mounted as specified .	Sign posts shall be resistant to major earthquakes and winds with speed of up to 70 mph.
Mounting supports and foundation	Posts shall be designed to be breakaway supports. They can be broken or yielded when struck by a vehicle.	

User Features	Operational Needs	Performance Parameters
<p>2. <u>Static Route Map</u></p> <p>A system map of Bronco Express Shuttle Services that presents routes to passengers waiting at bus stops.</p>		
<p>Static Route Map</p>	<p>A static route map shall be installed along with real-time transit arrival signs at each bus stop.</p>	<p>Each map shall be designed to meet the University's standards and guidelines. The standards and guidelines can be found at http://www.csupomona.edu/~fpm/Planning/procedures_guidelines/sign_design_manual.pdf.</p> <p>An example of route map is shown below:</p>  <p>All the maps shall be easily maintained.</p> <p>All exposed materials of maps shall remain from damage and are protected from moisture, dust, dirt, and corrosion.</p> <p>Each map shall be ADA compatible.</p>

User Features	Operational Needs	Performance Parameters															
Direction of shuttle movement and location of stops	Each map shall display direction of shuttle movement and location of stops on its route.	A special symbol "You Are Here" shall be provided to indicate its stop															
<p><u>3. Traveler Information Provider</u></p> <p>Traveler Information Provider services within the Bronco Express EDAPTS system consist of three functions: web Server, voicemail system and text messaging service system.</p>																	
Web Server	The Bronco Express EDAPTS system shall have a web server that provides real-time information about the shuttle service and provides real-time bus operational information through a series of user-friendly web pages.	<p>The Cal Poly Pomona web site shall have a link to the EDAPTS system web site. With this link, students, faculty, and visitors can easily access to the dynamic information provided by the EDAPTS system web site.</p> <p>The information provided by the web server shall include the following items at a minimum.</p> <ul style="list-style-type: none"> ▪ Real time schedule <p>Real time schedule information should be grouped by route. For each route, a summary table should be provided to show estimated bus arrival time at bus stops on the route. An example of the table for Route A is shown in the below table.</p> <table border="1" data-bbox="1310 1105 1856 1344"> <thead> <tr> <th>Stop #</th> <th>Name</th> <th>Arrival Time</th> </tr> </thead> <tbody> <tr> <td>Stop 1</td> <td>Business Building</td> <td>In XX min</td> </tr> <tr> <td>Stop 2</td> <td>Rose Garden</td> <td>In XX min</td> </tr> <tr> <td>Stop 3</td> <td>Police Station</td> <td>In XX min</td> </tr> <tr> <td>Stop 4</td> <td>CLA Building</td> <td>In XX min</td> </tr> </tbody> </table>	Stop #	Name	Arrival Time	Stop 1	Business Building	In XX min	Stop 2	Rose Garden	In XX min	Stop 3	Police Station	In XX min	Stop 4	CLA Building	In XX min
Stop #	Name	Arrival Time															
Stop 1	Business Building	In XX min															
Stop 2	Rose Garden	In XX min															
Stop 3	Police Station	In XX min															
Stop 4	CLA Building	In XX min															

User Features	Operational Needs	Performance Parameters																																				
		<table border="1" data-bbox="1310 315 1858 545"> <tr> <td>Stop 5</td> <td>Information Booth</td> <td>In XX min</td> </tr> <tr> <td>Stop 6</td> <td>Outside Village</td> <td>In XX min</td> </tr> <tr> <td>Stop 7</td> <td>Village</td> <td>In XX min</td> </tr> <tr> <td>Stop 8</td> <td>Farm Store</td> <td>In XX min</td> </tr> <tr> <td>Stop 9</td> <td>Health Center</td> <td>In XX min</td> </tr> </table> <p data-bbox="1310 578 1873 634">An example of the table for Route C is shown in the below table.</p> <table border="1" data-bbox="1310 667 1858 1024"> <thead> <tr> <th>Stop #</th> <th>Name</th> <th>Arrival Time</th> </tr> </thead> <tbody> <tr> <td>Stop 1</td> <td>Marketplace</td> <td>On Break</td> </tr> <tr> <td>Stop 2</td> <td>Parking Lot M (A)</td> <td>On Break</td> </tr> <tr> <td>Stop 3</td> <td>Parking Lot B</td> <td>On Break</td> </tr> <tr> <td>Stop 4</td> <td>Between Lot B and K (Village)</td> <td>On Break</td> </tr> <tr> <td>Stop 5</td> <td>Parking Lot K</td> <td>On Break</td> </tr> <tr> <td>Stop 6</td> <td>Parking Lot M (B)</td> <td>On Break</td> </tr> </tbody> </table> <ul data-bbox="1255 1089 1906 1300" style="list-style-type: none"> ▪ Context menu This menu allows users to click a stop graphically on the system map and see the real time schedule at the selected stop. ▪ Location of all in-service buses <p data-bbox="1310 1333 1829 1360">A web page should be provided to show the</p>	Stop 5	Information Booth	In XX min	Stop 6	Outside Village	In XX min	Stop 7	Village	In XX min	Stop 8	Farm Store	In XX min	Stop 9	Health Center	In XX min	Stop #	Name	Arrival Time	Stop 1	Marketplace	On Break	Stop 2	Parking Lot M (A)	On Break	Stop 3	Parking Lot B	On Break	Stop 4	Between Lot B and K (Village)	On Break	Stop 5	Parking Lot K	On Break	Stop 6	Parking Lot M (B)	On Break
Stop 5	Information Booth	In XX min																																				
Stop 6	Outside Village	In XX min																																				
Stop 7	Village	In XX min																																				
Stop 8	Farm Store	In XX min																																				
Stop 9	Health Center	In XX min																																				
Stop #	Name	Arrival Time																																				
Stop 1	Marketplace	On Break																																				
Stop 2	Parking Lot M (A)	On Break																																				
Stop 3	Parking Lot B	On Break																																				
Stop 4	Between Lot B and K (Village)	On Break																																				
Stop 5	Parking Lot K	On Break																																				
Stop 6	Parking Lot M (B)	On Break																																				

User Features	Operational Needs	Performance Parameters
		<p>Bronco Express system map and locations of all the service buses on the map. The location should be updated in a regular interval (for example, every 30 seconds) to reflect the real location of buses.</p> <ul style="list-style-type: none"> ▪ Rider information on bus (full or not full) <p>Rider information on bus should be provided on the EDAPTS system web site. This information shall be integrated into the web page that displays current bus locations.</p> <ul style="list-style-type: none"> ▪ “Out of Service” indication (due to failure) <p>When a bus fails to provide shuttle service, the “Out of Service” indication should be displayed for the bus on the EDAPTS system web site.</p> <ul style="list-style-type: none"> ▪ Information about breaks and lunches <p>Information about schedules of breaks and lunches should be provided on the web site for each bus.</p> <p>Bronco Express EDAPTS system shall allow web-enabled phones or PDAs to access its web site. When a phone or a PDA links to the web site, the caller can key in route and stop numbers and receive the following message: “Route X bus at stop [X] in [XX] min.”</p>

User Features	Operational Needs	Performance Parameters
Voicemail System	Bronco Express EDAPTS system shall have an automated voicemail system that can be called to get information on bus arrival time at a specific stop of interest.	<p>The voicemail system shall be operated when the Bronco Express EDAPTS system is in service.</p> <p>After callers dial dedicated phone number(s) (such as 909-869-xxxx and 909-869-yyyy), they can enter route and stop number by either voice and/or numeric keypad. The voice phone system then sends a voice back to the callers.</p> <p>The response message shall be similar to: "Route X will arrive at your stop [stop name, stop number] in [XX] minutes."</p> <p>The voicemail system shall have a "repeat" function to allow callers to listen response messages repeatedly.</p>
Text Message Service	Bronco Express EDAPTS system shall have an automated text message service that can be called to get information on bus arrival time at a specific stop of interest.	<p>The text message phone service shall be operated when the Bronco Express EDAPTS system is in service.</p> <p>After callers dial a dedicated phone number (such as 909-869-xxxx), they can send a text message about route and stop number. The text message then sends a text message back to the callers.</p> <p>The response message shall be similar to: "Route X will arrive at your stop [stop name, stop number] in [XX] minutes."</p>

User Features	Operational Needs	Performance Parameters
<p><u>4. On-Board System</u></p> <p>Equipment and software installed in a transit vehicle to perform transit management functions. On-board systems for the Bronco Express EDAPTS system will include a Mobile Data Terminal and associated peripherals such as magnetic stripe card reader, on-board annunciator and electronic message sign, automatic passenger counter (APC) and driver's emergency button.</p> <p>There are six buses in service every day and two spare buses as backup for the Bronco Express system. Eight on-board systems are required for the EDAPTS system.</p>		
<p>Mobile Data Terminal (MDT)</p>	<p>To reduce driver workload and improve operational efficiency, a way is needed to automatically collect and display time stamped information on significant operational events.</p>	<p>The MDT shall have the following minimal capabilities to support daily operations:</p> <ul style="list-style-type: none"> • Allows a driver to login the Bronco Express EDAPTS system using their Bronco Express employee ID. The login process and validation shall be completed in less than 2 minutes. • Collects odometer at the beginning and end of deadhead, at the beginning and end of service (work), and at fuel stops. • Displays actual time clock in a large digit format and removes all other information from the display when the bus reaches a speed of 5 mph or more. Clock shall be synchronized with the clock time shown on dispatch EDAPTS consoles. • Displays important stop information to the driver when a service bus arrives at a stop. At a minimum, this information shall consist of the following items.

User Features	Operational Needs	Performance Parameters
		<ul style="list-style-type: none"> - What the stop ID is - What the current time is - How many minutes remain at the stop before the bus needs to leave for the next stop. Countdown shall be displayed second by second until departure for the stop. • Allows a driver to press a “Boarding” button to manually record passenger count each time a passenger boards. • Allows a driver to change shifts within the Bronco Express EDAPTS system. The MDT shall automatically collect all the data related to the shift change and store it into permanent storage. At a minimum, this information shall consist of the following items. <ul style="list-style-type: none"> - Date - Time - Odometer - Route - Location - Drivers involved. • Allows a driver to logout of the Bronco Express EDAPTS system. • Stores bus operational data and transmits it at regular intervals to the central site during normal operations/end of work day/periods/non-use hours/etc. At a minimum, this information shall consist of the following items.

User Features	Operational Needs	Performance Parameters
		<ul style="list-style-type: none"> - Speed - Time stamp - Geolocation (bus location) data. <ul style="list-style-type: none"> • The MDT shall prompt drivers for odometer reading at the time of fueling. A “Fueling” function should be provided on the MDT menu list.
Automatic Passenger Counter (APC)	To collect ridership information for developing and retuning bus schedules	<p>APC shall be installed on all buses, if budget allows.</p> <p>APC shall be customized to fit into existing shuttle buses.</p> <p>When an APC device is installed on service buses; it should be fully integrated with the MDT on the bus.</p> <p>Passenger counts generated by the APC device should be displayed on the MDT, if budget allows.</p> <p>APC shall collect boarding and alighting data of passengers.</p> <p>Directional sensors are installed above doors of buses, where they detect people coming in or going out of the vehicle.</p>
Emergency Button	To provide emergency response measures to improve safety and security of passengers and drivers.	The Bronco Express EDAPTS system shall have an emergency button function on the bus. The function shall be resistant to accidental activation, and shall be able to be unobtrusively activated by the driver. When a driver holds the button down for one and a half seconds, a silent emergency signal is sent from the

User Features	Operational Needs	Performance Parameters
		<p>MDT to the dispatch center via the communications link.</p> <p>The Bronco Express EDAPTS system shall implement a preprogrammed emergency response protocol and procedure. Also the system shall have capabilities to handle coded messages between drivers and dispatchers for false alarms.</p> <p>The Bronco Express EDAPTS system shall release the “Emergency Mode” and change back to its normal status after an emergency event is confirmed over.</p>
<p>5. Central Site Software</p> <p>Software that will run at a fixed location to receive, transmit, store, and facilitate the exchange of data between other components. Such software typically provides an interface to communicate with On-Board and Roadside components; store and retrieve collected system data, and provide Application Programming Interfaces (APIs) to both ATRMS and Traveler Information systems.</p> <p>It consists of a set of functional processes and APIs (including Roadside Information Display API, Traveler Information API, ATRMS API, and Data Store API).</p>		
Central Site Software	The Bronco Express EDAPTS System shall have Central Site Software	<p>The Central Site Software shall be installed at the University’s Dispatcher Office and the Laidlaw’s Dispatcher’s office.</p> <p>The Central Site Software at the two locations shall be synchronized. Changes done by software at one site shall be reflected at another site.</p>

User Features	Operational Needs	Performance Parameters
		<p>Central Site software shall make alerts to dispatchers via audible and visual alarms, when it receives emergency signals from on-board systems.</p> <p>Central site software shall have capabilities to handle audio/visual/cellular notification of emergencies other than the emergency button on buses.</p> <p>Response to emergency conditions involves 1) making alerts to dispatchers, 2) locking out all normal functions, 3) setting "Tracking Mode" to the bus having the emergency, 4) clearing the alarms and the emergency response function, and 5) unlocking all normal functions.</p> <p>Cal Poly Pomona PTS shall develop an emergency response protocol and procedures. Central site software shall implement the response protocol and procedures. The CP San Luis Obispo's procedures should be included for reference.</p>
<p>6. Advanced Transit Management System</p> <p>A software application that will run at locations such as the dispatch center and other management offices, typically providing personnel with information such as vehicle position and location, schedule adherence data, boarding and ridership data, and statistical analysis and reporting of the above functions.</p> <p>The ATRMS consists of features for vehicle tracking display, schedule adherence display, passenger boardings display, emergency management display, ridership statistics reporting, and schedule adherence statistics reporting. Also it has a set of controls including 1) system user management controls, 2) on-board equipment administration controls, 3) schedule management & administration tools and controls, and 4) roadside information display controls.</p>		

User Features	Operational Needs	Performance Parameters
Vehicle Tracking Display	The Bronco Express EDAPTS system shall provide geolocation tracking display of transit vehicles for dispatch & management users	<p>Tracking shall be available on a map-based and/or tabular display</p> <p>Vehicles & routes shall be color coded and easily discernable to all dispatchers</p> <p>Both vehicles and routes shall be selectable for display on a per-route basis</p> <p>Information displayed shall include vehicle number, current stop, next stop, schedule adherence, scheduled arrival time, boardings, etc</p>
Schedule Adherence Information Display	The Bronco Express EDAPTS system shall display schedule adherence information for dispatch & management users	<p>Schedule adherence information shall be selectable on a per route / per day basis</p> <p>Schedule adherence information shall be presented for all stops on all runs on a route during the day</p> <p>Schedule adherence information shall be presented to show stop location, scheduled arrival time, and schedule deviation</p> <p>Schedule adherence information shall be presented on the GUI screen as well in PDF and CSV file formats.</p>
Passenger Boarding/Alighting Information Display	The Bronco Express EDAPTS system shall display passenger boarding / alighting information for dispatch & management users	<p>Passenger boarding / alighting information shall be selectable on a per route / per day basis</p> <p>Boarding / alighting information shall be presented for all stops on all runs on a route during the day</p> <p>Boarding / alighting information shall be presented to include stop location 4.) schedule adherence information shall be presented on the GUI screen as</p>

User Features	Operational Needs	Performance Parameters
		well in pdf and csv file formats
Driver Emergency Button Handler	The Bronco Express EDAPTS system shall handle driver emergency button alarms for dispatch and management users	<p>This feature shall allow dispatchers to receive driver alarms and respond appropriately.</p> <p>This feature shall allow dispatcher to track vehicle while coordinating with local law enforcement</p>
Statistical Ridership Report	The Bronco Express EDAPTS system shall provide statistical ridership reports for dispatch & management users	<p>Reports shall display riders as a distribution of number of rides/passenger/month</p> <p>Reports shall display ridership statistics on a per route per time period basis</p> <p>Reports shall provide accuracy indicating percentage of stops reporting on a per trip per route basis</p> <p>Reports shall be provided in one or more user selected file formats such as: (a) graphical GUI display, (b)PDF, or (c) CSV formats</p>
Statistical schedule adherence Report	The Bronco Express EDAPTS system shall provide statistical schedule adherence reports for dispatch & management users	<p>Reports provide statistical representation of out-of-tolerance stop arrivals.</p> <p>Reports shall list all out of tolerance stop arrivals with day, route, time, scheduled arrival time, actual arrival time, deviation, and vehicle ID included</p>
Schedule Building & Dissemination tools	The Bronco Express EDAPTS system shall provide schedule building & dissemination tools for dispatch & management users	<p>Tools shall be able to build or modify schedules on an individual route basis</p> <p>Tools shall allow operations on current and past schedules</p>

User Features	Operational Needs	Performance Parameters
		<p>Schedules shall be disseminated in whole or on a route-by-route basis</p> <p>Schedule tools shall manage system holiday and weekend variations of the schedule</p> <p>Schedule tools shall manage stop lists</p> <p>Schedule tools shall support an unlimited number of day types for building a schedule</p>
Smart Sign Administration Tools	The Bronco Express EDAPTS system shall provide smart sign administration tools for dispatch & management users	<p>Tools shall allow status of all signs to be queried and displayed</p> <p>Tools shall allow new schedules to be deployed to all signs</p> <p>Tools shall allow route and stop assignments to be sent to individual sign</p> <p>Tools shall allow new executable code to be sent to individual signs</p>
On-Board Systems Administration Tools	The Bronco Express EDAPTS system shall provide on-board systems administration tools for dispatch & management users	<p>Tools shall allow status of all on-board systems to be queried and displayed</p> <p>Tools shall allow new schedules, application software executables, and configuration data to be sent to individual or all buses</p> <p>Tools shall allow any collected data to be manually retrieved from individual or all buses</p> <p>Tools shall allow operating system patches to be remotely applied to individual or all buses</p>

User Features	Operational Needs	Performance Parameters
Controls for Roadside Banner Message Display	The Bronco Express EDAPTS system shall provide controls for roadside banner message display	<p>Tools shall allow free-form and/or pre-defined banner messages to be sent to selected signs</p> <p>Tools shall allow signs to be selectively or collectively disabled</p> <p>Tools shall allow new schedules to be downloaded to signs</p> <p>Tools shall collect diagnostic and fault information from signs (optional, requires 2-way communications with signs)</p>
User management Tools	The Bronco Express EDAPTS system shall have tools to manage users.	The system shall provide the ability to add, edit, and delete ATRMS console users

Appendix B

Components and Elements as Defined by the EDAPTS High-Level Design

1) Vehicle On-Board Systems

The Vehicle On-Board Systems are the equipment and software to be installed in the Bronco Express shuttle buses to perform transit management functions. They include the following elements and functions:

- Mobile Data Terminal (MDT) A device that provides the driver access to various functions such as schedule adherence status, passenger boarding status, time of day, time of day, route being driven. The MDT provides driver input and output functions and is likely connected to other on-board elements.
- MDT Functional Processes Software that executes on the MDT to perform functions such as detecting bus stops and accepting data from devices such as an Automatic Passenger Counter
- MDT Vehicle Wireless Data Communications System Driver Software that executes on the MDT interface to the Vehicle Wireless Data Communications System. This software performs data encoding/decoding.
- Automatic Passenger Counter (APC) Devices mounted at all bus entry and exit locations that detect passengers embarking and disembarking from the bus. APCs keep track of the total number of people riding on the bus at any given time. Data can be downloaded at the end of the day or transferred to other on-board devices such as the MDT.
- Emergency Actuator A device that drivers can utilize to send an emergency notification or "Mayday" message to the dispatcher indicating they have a situation on their bus that poses a physical threat to the driver and/or passengers. The Emergency Actuator must be installed in the driver's compartment so that the driver could actuate it without being noticed by anyone else on the bus.

2) Vehicle Wireless Data Communication System

The Wireless Data Communications System is used for communications between the Central Dispatch Center and Vehicle On-Board Systems. This system allows the Bronco Express shuttle buses to communicate position, stop arrivals and departures, boarding information, etc. to the Central Dispatch system.

The system consists of the following elements:

- On-Board Data Interface A vehicle on-board device, such as a modem or a data communications card. This device allows the on-board computational equipment (the MDT) to make a data communications connection to the Central Site.
- On-Board Communications Infrastructure / Repeaters Equipment that serves for bi-directional wireless data communications transmissions between the Central Site and the Vehicle On-Board Systems.
- Central-Site Data Interface A device such as a modem, a data communications card, or a network access card that allows the Central Site Communications servers to make a wireless data connection to vehicle On-Board Systems.

3) Dynamic Roadside Information Display

The Dynamic Roadside Information Display is an electronic, remotely controlled display that presents information regarding estimated time of arrival of buses to passengers waiting at bus stops. These displays provide "real-time" information based upon bus progress along route.

The Dynamic Roadside Information Display (RID) consists of the following elements:

- Roadside Sign / Display A device (installed on a structure, post or pole) that presents "live" data regarding estimated time of arrival or minutes until arrival for shuttle buses arriving at a stop. This sign/display can display information for more than one route at a given stop and can display other messages such as public service announcements or system status information.
- Roadside Post/Pole A post or pole that supports the Roadside Information Display.
- Roadside Post Foundation The foundation for the Roadside Post/Pole.
- RID Functional Processes Software that executes on the RID and receives messages from the Central Site and performs functions such as calculating estimated minutes for arrival for buses and formatting public service messages for display.
- RID Communications System Driver Software that executes on the RID and interfaces to the RID Data Communications System.

4) Roadside Data Communications System

The Roadside Data Communications System provides the wireless or wired communications from the Central Dispatch Site to roadside information displays. This communications link allows the signs to know vehicle locations on route so that the roadside information display can display estimated minutes until arrival for routes at stops.

The Roadside Data Communications System consists of the following elements:

- Roadside Data Interface A device, such as a modem, a data communications card, or a network access card that allows the Dynamic Roadside Information Display to make a data communications connection to the Central Site.
- Roadside Communications Infrastructure / Repeaters Equipment, located on mountaintops, buildings, poles, etc. that serves a relay station for uni-directional or bi-directional wireless data communications transmissions between Roadside Information Displays and the Central Site.
- Central-Site Data Interface A device such as a modem, a data communications card, or a network access card that allows the Central Site communications servers to make a data communications connection to buses via the On-Board Wireless Communications system.

5) Central Site Software (Server)

The Central Site Software (CSS) runs at a fixed, central location to receive, transmit, store, and facilitate the exchange of data between other EDAPTS components. It provides interfaces to communicate with On-Board and Roadside components, stores and retrieves collected system data, and provides Application Programming Interfaces (APIs) to both Advanced Transit Management System (ATRMS) and Traveler Information systems.

The Central Site Software consists of the following elements:

- On-Board Systems API A software application that runs at the Central Site and communicates with all Mobile Data Terminals (MDTs) in the bus fleet via the Central Site Wireless Data Interface and the On-Board Communications Infrastructure and Repeaters. This communications server provides all access to Mobile Data Terminals in vehicles for the Central Site.
- ATRMS API A software application that runs at the Central Site and provides a set of functions that return information to support all ATRMS GUI screens.
- Data Store A software application or function (most likely a DBMS) that provides short term and long term storage of all system data received from shuttle buses and system schedules.

- Data Store API An application programming interface that provides read-write access to the Data Store for software applications such as the Central Site Software and the ATRMS.
- CSS Functional Processes Software that executes at the Central Site to perform functions such as calculating schedule adherence, processing driver emergencies, generating reports, managing schedules, etc.
- CSS Vehicle Wireless Data Communications Systems Driver Software that executes at the Central Site and interfaces to the Vehicle Wireless Data Communications System..
- CSS ATRMS Data Communications System Driver Software that executes at the Central Site and interfaces to the ATRMS Communications System.
- Roadside Information Display API A software application that runs at the Central Site and communicates with all Roadside Information Displays via the Central Site Data Interface and the Roadside Communications Infrastructure and Repeaters. This communications server provides all access to Roadside Information Displays for the Central Site.
- CSS RID Data Communications System Driver Software that executes at the Central Site and interfaces to the RID Communications System.
- Traveler Information API A software application that runs at the Central Site and provides a set of functions that return information regarding vehicle location on route, schedule adherence, and vehicle seat availability to applications that will provide this information the public through various communications and display schemes.

6) Advanced Transit Management System (ATRMS)

The Advanced Transit Management System (ATRMS) is a software application that runs at locations such as the Cal Poly Pomona's Dispatch Center and the Laidlaw office. It provides personnel with information such as vehicle position, schedule adherence data, boarding and ridership data, and statistical analysis and reporting of the above functions.

The ATRMS consists of the following elements:

- Vehicle On-Board Equipment Administration Controls A GUI screen with controls that allows a management user to administer the MDT computer and its operating system remotely from the Central Site. Administration capabilities include loading new configuration files, software executables, system schedules / timetables, and retrieving log files of various system functions. These administration tools give the remote administrator the same tools they would have if they were connected into the MDT's operating system via a hard-wire connection.

- Schedule Management & Administration Tools & Controls A GUI screen with controls that allows a management user to build, modify, or delete system schedules by time period, route, or the system.
- ATRMS Data Communications System Driver Software that executes on the ATRMS interface to the ATRMS Communications System.
- Driver Management Controls A GUI screen with controls that allows the addition, removal and editing of drivers and driver information within the system.
- Emergency Management Display A GUI screen that alerts a dispatch and/or management user when a driver has depressed his or her emergency actuator. This screen creates audible and visible indications of the emergency conditions and does not allow any other activity on any ATRMS console until the emergency has been acknowledged and coordination responsibility is assumed by a dispatch or management user. It enables continuous "live" tracking of the vehicle reporting the emergency and allows the emergency to be closed out and automatically logged when it is over.
- Roadside Information Display Controls A GUI screen with controls that allows a management user to reconfigure Roadside Information Displays to serve different stops, update their schedules, or update them with public service or system status banner messages.
- Vehicle Tracking Display A GUI screen with controls that allows a dispatch and/or management user to observe real-time vehicle positions. The screen may display information in a map-based or tabular form, depending upon specific user requirements.
- Schedule Adherence Display A GUI screen with controls that allows a dispatch or management user to observe vehicle schedule adherence by stop, trip, route, hour, or day.
- Passenger Boarding Display: A GUI screen with controls that allows a dispatch and/or management user to observe passenger boardings by stop, trip, route, hour, or day.
- Ridership Statistics Reporting Controls: A GUI screen with controls that allows a dispatch or management user to generate reports regarding ridership statistics by stop, trip, route, hour, or day.
- Schedule Adherence Statistics Reporting Controls A GUI screen with controls that allows a dispatch or management user to generate reports regarding vehicle schedule adherence by stop, trip, route, hour, or day. Reports generated may be either statistical or exception based in nature.
- System User Management Controls A GUI screen with controls that allows a management user to create new system users, modify the permissions of existing users, or delete users.

7) ATRMS Communications System

The ATRMS Communications system is responsible for communications between the Dispatch Center and the ATRMS.

The ATRMS Communications System consists of the following elements:

- ATRMS / Central-Site Data Interfaces The local area networking (LAN) cards installed in the Central Site workstations and servers.
- ATRMS Communications Infrastructure / Repeaters The local area networking (LAN) equipment used to connect central-site workstations and servers to each other and to remote ATRMS clients via the Internet.

8) System Input Data

System Input Data contains the information required to be included into the Bronco Express EDAPTS system. This information includes stop-point references, schedules and timetables, map data, and valid driver and rider lists.

The System Input Data consists of the following elements:

- Stop-Point List The master list of all stops in the shuttle bus system. Each stop has a unique identifier number or designation as well as latitude, longitude, and direction of travel for the stop. It may also include other identification information such as common building/street names, intersection and/or stop name.
- Timetable The master schedule for the shuttle bus system, indicating all routes, trips, and stops on trips in the system.
- Work / Runs List The master list of all runs in the system.
- Valid Drivers List A list of valid bus fleet drivers.



CALIFORNIA STATE POLYTECHNIC UNIVERSITY, POMONA

Procurement and Support Services
Administrative Affairs

Request for Proposal

RFP No. 07-014

Bronco Express EDAPTS

(Efficient Deployment of Advanced Public Transportation
System)

California State Polytechnic University, Pomona
Procurement & Support Services
2740 S. Campus Drive, Building 75
Pomona, CA 91768

Contact: Debra Garr
Procurement & Support Services
Telephone: 909-869-3383
Fax: 909-869-5475
daschneck@csupomona.edu

RFP Release Date: February 8, 2008
Proposal Due Date: March 3, 2008

TABLE OF CONTENTS

	Page
1. Definition of Terms	7
2. California State University System Overview	9
3. Project Background	9
4. Existing Bronco Express Shuttle Bus Service	10
5. Scope of Work	11
5.1 Primary Contract	11
Task 1 Provide EDAPTS System Components and Elements	12
Task 2 Installation and Preliminary Testing	19
Task 3 System Acceptance Test and System Delivery	19
Task 4 60-Day Research Evaluation	20
5.2 Warranty and Maintenance Service Contract	20
5.3 Schedule, Milestones, and Deliverables	21
6. Contractor Bid Requirements	24
6.1 Contractor Deliverables	24
6.2 Campus Contacts	24
6.3 Submittal Instructions	25
6.3.1 Submittal Location	25
6.3.2 Timeline	26
6.3.3 Proposal Package	26
7. EVALUATION OF PROPOSALS	31
7.1 General Discussion of Evaluation Process	31

7.2	Impact of Proprietary Data on Evaluation	31
7.3	Use of Direct or Indirect Research Support Funding	32
7.4	Proposal Evaluation	32
7.4.1	Evaluation Criteria	32
8.	CONTRACT NEGOTIATION	34
9.	GENERAL PROVISIONS FOR SERVICE ACQUISITIONS	35
9.1	Commencement of Work	35
9.2	Invoices	35
9.2.1	Invoice Submittal	35
9.2.2	Additional Services	35
9.2.3	Continuing Services	35
9.2.4	Payment Processing Delay	35
9.2.5	Payment in Full	35
9.3	Contract Conditions and Limitations	36
9.3.1	Funding Appropriation	36
9.3.2	Return of Commodities	36
9.4	Contract Cancellation	36
9.5	Independent Status	36
9.6	Conflict of Interest	37
9.6.1	Full Disclosure	37
9.6.2	Statement of Economic Interests	37
9.7	Governing Law	37
9.8	Assignments	37
9.9	Time	38

9.10	Contract Alterations & Integration	38
9.11	General Indemnity	38
9.12	Use of Data	38
9.13	Termination for Default	38
9.14	Personnel	39
9.15	Nondiscrimination	39
9.15.1	Religion, Race, Ethnicity, Sex, Disability	39
9.15.2	Fair Employment and Housing Act	39
9.16	Drug-Free Workplace Certification	40
9.17	Severability	40
9.18	Disputes	41
9.19	Privacy of Personal Information	41
9.20	Waiver of Rights	41
9.21	Endorsement	42
9.22	Patent, Copyright, and Trade Secret Indemnity	42
9.22.1	Legal Defense Against Claims	42
9.22.2	Mitigation of Claim Violations	43
9.23	Compliance with NLRB Orders	43
9.24	Examination and Audit	43
9.25	DVBE and Small Business Participation	44
9.26	Citizenship and Public Benefits	44
9.27	Americans With Disabilities Act (ADA)	44
9.28	Child Support Compliance Act	44
9.28.1	Child and Family Support Obligations	44

9.28.2	Earnings Assignment Orders	45
9.29	Document Referencing	45
9.30	Forced, Convict, Indentured and Child Labor	45
9.31	Covenant Against Gratuities	45
9.32	Rights and Remedies of University for Default	46
9.32.1	Failure to Perform as Required	46
9.32.2	Failure to Deliver Promptly	46
9.32.3	Termination Loss or Damage Recovery	46
9.32.4	Other Rights and Remedies	47
9.33	Contractor's Power and Authority	47
9.34	Recycled Content Certification	47
9.35	Entire Contract	47
9.36	Safety and Accident Prevention	47
9.37	Follow-On Contracts	48
9.37.1	“Consulting and Direction” Defined	48
9.37.2	“Affiliates” Defined	48
9.37.3	Exclusions	48
9.38	Expatriate Corporations	49
9.39	Insurance Requirements	49
9.39.1	Certificate of Insurance Contents	49
9.39.2	Bodily Injury Coverage	49
9.39.3	Workers Compensation Insurance	50
9.40	Rights in Work Product	50
9.40.1	Software Rights	50

9.40.2	Government Purpose Rights	51
9.40.3	Development Of Competitive Products	51
9.41	Confidentiality of Data	51
10.	Exhibit A: EDAPTS System Requirements and Performance Specifications	53
11.	Exhibit B: EDAPTS Data Formatting Standards	53
12.	Exhibit C: Cal Poly Pomona EDAPTS Test Deployment Operations Descriptions	53
13.	Exhibit D: Descriptions of Bus Stops for EDAPTS Test Deployment	53
14.	Exhibit E: Sample Reports	53
15.	Exhibit F: Descriptions of WiFi Services at Cal Poly Pomona	53

1. DEFINITION OF TERMS

For the purposes of this Request for Proposal, the following definitions are used:

API	Application Programming Interface
ATRMS	Advanced Transit Management System; The GUI-based controls & screens that let users access the EDAPTS system
AVL	Automated Vehicle Location
Bid	The offer to provide the goods and services requested within this Request for Proposal for a fee or other consideration.
Bidder	The person or firm responding to this RFP
Contractor	The person or firm responding to this RFP
Consultant	A person or firm retained by the Contractor for work related to this RFP. The Consultant's duties generally require them to provide expert input and recommendations on specific issues related to the RFP.
CSU	California State University
EDAPTS	Efficient Deployment of Advanced Public Transportation System
GUI	Graphical User Interface
ITS	Intelligent Transportation Systems: The utilization of technology to solve transportation problems.
LEAP	Localized Encryption and Authentication Protocol
May	Indicates something that is not mandatory but permissible.

Proposal	The written description of the offer to provide the goods and services requested within this Request for Proposal for a fee or other consideration.
RFP	Request for Proposal
Shall	A mandatory requirement if commercially available
Should	A recommended requirement if commercially available, but not mandatory.
Subcontractor	An individual or company retained by the Contractor for work related to this RFP. The Subcontractor's duties generally require it to perform a specific task (or tasks) as part of the overall project being done by the Contractor.
Submittal Deadline	The date and time on/or before all proposals must be submitted and received in the Procurement and Support Services office, Cal Poly Pomona campus.
Selected Contractor	The person, contractor, or firm whose proposal is selected and to whom the contract award is made.
Supplier/Vendor	An individual or company retained to supply parts and/or materials related to the work being done by the Contractor, Consultants or Subcontractors on this RFP.
VPN	Virtual Private Network

2. CALIFORNIA STATE UNIVERSITY SYSTEM OVERVIEW

The California State University (CSU) is a 23-campus, statewide system of comprehensive and polytechnic universities. The CSU awards bachelors and masters degrees in approximately 240 subject areas. The CSU has more than 46,000 faculty members and provides education for over 417,000 students system-wide. The CSU is one of the largest, most diverse university systems in the country. The Board of Trustees sets policy and the Office of the Chancellor oversees system-wide management.

Cal Poly Pomona is one of the 23 campuses within the CSU system. It covers 1,438 acres of rolling green hills and is the second largest (in area) in the CSU system. Cal Poly Pomona is located less than 30 miles east of downtown Los Angeles. Cal Poly Pomona serves 17,306 undergraduates and offers undergraduate and master degrees in seven colleges.

3. PROJECT BACKGROUND

The purpose of this Request for Proposal (RFP) is for California State Polytechnic University, Pomona (hereinafter referred to as Cal Poly Pomona or the University) to contract with a fully qualified and experienced system Contractor to provide the University with technical services for the design, installation, test, maintenance of a small transit Intelligent Transportation System (ITS) on the Bronco Express campus shuttle system.

This procurement will implement the Efficient Deployment of Advanced Public Transportation System (EDAPTS) as outlined in this document. EDAPTS is a small transit focused ITS research program that is being funded by the Federal Transit Administration (FTA) and California Department of Transportation (Caltrans) and Cal Poly Pomona Parking and Transportation Services. Having completed the initial research phase of this program, the EDAPTS research project is now ready for its last hurdle – commercialization and deployment readiness.

Cal Poly Pomona is taking the lead in a transitional test deployment of EDAPTS through this RFP. The Cal Poly Pomona EDAPTS test deployment demonstration (hereinafter referred to as the Bronco Express EDAPTS system) will provide low cost ITS solutions to problems currently being experienced on the University's on-campus shuttle bus service. With the Bronco Express EDAPTS system in place, the users of the shuttle service will be able to determine the current locations of all the Bronco Express shuttle buses, and

expected real-time arrivals of buses at individual bus stops in real-time. Additionally, it is anticipated that the system will help Bronco Express improve its schedule adherence and better maintain evenly spaced bus headways. Through this test deployment, the commercialization of the EDAPTS small transit system concepts will be assessed and facilitated. Experience and knowledge gained from the test deployment will assist small and medium transit properties in adopting the EDAPTS lower cost approach to procuring ITS technologies.

The University is seeking proposals from qualified contractors, suppliers and vendors to supply the University with Advanced Public Transportation System (APTS) equipment that satisfies the EDAPTS requirements and performance specifications provided in Exhibit A, EDAPTS System Requirements and Performance Specifications. The successful contractor shall provide pricing for the following:

- equipment;
- software;
- installation;
- preliminary testing for the equipment installed in this RFP;
- final testing of the Dynamic Roadside Information Display (signs) upon completion of Phase I in installed environment;
- employee training necessary to make the Bronco Express EDAPTS operational and fully functional; and
- on-going technical and maintenance service contracts.

4. EXISTING BRONCO EXPRESS SHUTTLE BUS SERVICE

The University currently contracts with Laidlaw Transit Services, Inc. (hereinafter referred to as Laidlaw or Service Provider) to provide the day-to-day management and operations of the on-campus Bronco Express shuttle bus service from September 21, 2006 to June 30, 2009. The current Bronco Express shuttle system employs eight buses:

- six buses owned and operated by the shuttle bus Service Provider; and
- two spare state owned buses operated by Cal Poly Pomona employees.

The Bronco Express shuttles provide free services to students, faculty, staff and visitors.

The University and the Service Provider currently use separate dedicated voice radio communications to communicate between their own drivers and dispatchers. Since the two voice radio systems are independent, Service Provider drivers cannot talk to the University's dispatcher and vice versa.

For more information about the operation of the existing and envisioned post-EDAPTS Bronco Express Shuttle bus systems, please see Exhibit C, Cal Poly Pomona EDAPTS Test Deployment Operations Descriptions. This Exhibit is included for reference and historical background only, and does not constitute requirements.

5. SCOPE OF WORK

The Cal Poly Pomona EDAPTS test deployment project will be conducted in two phases. The first phase will involve the installation of EDAPTS system components and completion of a preliminary test. The second phase will involve 60-days research evaluation of the installed Bronco Express EDAPTS system and final delivery of the system.

This section describes the tasks that shall be addressed by Contractors to implement the EDAPTS system in a primary contract. It includes the work assignment process, milestones, deliverables, and due dates. Also it requires the Contractors to provide a maintenance service contract to the University for the EDAPTS system. The purpose of this maintenance service contract is to ensure the successful operations of the EDAPTS system after it is delivered to the University.

5.1 Primary Contract

The Contractor shall provide the University with all required technical services, training, hardware, software and material for installing and testing the Bronco Express EDAPTS system. This installation shall be done on Cal Poly Pomona Bronco Express campus shuttles and will be based on the performance specification requirements attached to this document as Exhibit A. At the end of this project, a fully functioning and operational system shall be delivered to Cal Poly Pomona.

To satisfy this Scope of Work, the Contractor will conduct and successfully complete the following tasks:

Phase I EDAPTS System Installation and Preliminary Testing

Task 1 Provide EDAPTS System Components and Elements

The Contractor for the Bronco Express EDAPTS system shall provide the University with the EDAPTS components and elements in the quantities indicated in Table 1.

The EDAPTS components and elements shall meet the specifications, needs and intents described in Exhibit A, EDAPTS Performance Specification Requirements and Exhibit B, EDAPTS Data Formatting Standards.

Contractor shall provide the University with the installation and testing schedule for the Bronco Express EDAPTS system.

Table 1: EDAPTS Components and Elements

EDAPTS Components	Quantities	Descriptions
Vehicle On-Board Systems	8	<p>Contractor shall provide eight (8) sets of Vehicle On-Board systems for the Bronco Express EDAPTS system. These shall be installed on the six in-service buses and two spare buses used by Bronco Express and shall include the following elements and features:</p> <ul style="list-style-type: none"> a) A driver accessible Mobile Data Terminal (MDT) b) A driver's emergency signaling button c) A manual passenger counter <p>\$ _____ equipment price</p> <p>\$ _____ equipment Installation</p> <p>An Automatic Passenger Counter (APC) is considered as an optional element and shall be listed as a separately priced item.</p> <p>\$ _____ APC price</p>

Table 1: EDAPTS Components and Elements (Cont'd)

EDAPTS Components	Quantities	Descriptions
<p>Vehicle Wireless Data Communications System</p>	<p>1</p>	<p>Contractor shall consider the following two wireless communications options for the Vehicle Wireless Data Communication System and propose the lowest lifecycle cost solution for the University.</p> <p>a) Dedicated RF voice/digital communications system</p> <p>b) Public wireless network provider such as Verizon, Sprint, T-Mobile, etc.</p> <p>A comparison of the options in terms of performance, purchase price, installation cost and estimated on-going operating and maintenance costs shall be provided within the proposal. Contractor shall recommend a preferred approach and use the preferred approach within the submitted proposal. In the absence of other overriding concerns, the lowest lifecycle cost option that meets the performance needs specified in this RFP is the preferred methodology.</p> <p>OPTION A: Dedicated RF voice/digital communications system \$ _____</p> <p>OPTION B: Public wireless network provider such as Verizon, AT&T, Sprint, T-Mobile, etc. \$ _____</p>

Table 1: EDAPTS Components and Elements (Cont'd)

EDAPTS Components	Quantities	Descriptions
Central Site Software (Server)	1	<p>The Bronco Express EDAPTS system shall provide an interface to communicate with the Vehicle On-Board Systems (and ultimately with the Dynamic Roadside Information Displays to be installed in Phase II of this project) shall store and retrieve collected data from system, and provide Application Programming Interfaces (APIs) to both ATRMS and Traveler Information Service.</p> <p>Central Site software and hardware will be installed in the University's Parking and Transportation Services (PTS) building.</p> <p>Central Site Software license fee (including installation at all sites): \$ _____</p> <p>Annual Central Site Software license renewal fee:</p> <p>Year 1 \$ _____</p> <p>Year 2 \$ _____</p> <p>Year 3 \$ _____</p> <p>Year 4 \$ _____</p> <p>Year 5 \$ _____</p> <p>NOTE: Open Source Software Is A Preferred Item Of This Procurement And Is Incentivized In The Scoring Of All Proposals.</p>

Table 1: EDAPTS Components and Elements (Cont'd)

EDAPTS Components	Quantities	Descriptions
<p>Advanced Transit Management System (Dispatch Client)</p>	<p>1</p>	<p>Contractor for the Bronco Express EDAPTS system shall provide and install an Advanced Transit Management System (ATRMS). The ATRMS will be physically located at the two dispatch centers: Cal Poly Pomona Parking and Transportation Services building and the campus shuttle bus Service Provider location. The Dispatcher Console for the ATRMS presents the Graphical User Interface (GUI) screen to the dispatcher. This screen shall be identical and synchronized at the two separate dispatcher centers. Any changes to the ATRMS GUIs that are made at one dispatcher center shall be automatically updated and mirrored to the ATRMS GUI at the other dispatcher center.</p> <p>The ATRMS Communications system within the Bronco Express EDAPTS System shall support the data communications between the Central Dispatch Center and the ATRMS.</p> <p>Advanced Transit Management System and Console equipment for the above mentioned dispatch center:</p> <p>\$ _____</p> <p>Installation of Advanced Transit Management System and Console equipment:</p> <p>\$ _____</p> <p>Sample reports that shall be generated by the ATRMS can be found in Exhibit E, Sample Reports.</p>

Table 1: EDAPTS Components and Elements (Cont'd)

EDAPTS Components	Quantities	Descriptions
Dynamic Roadside Information Display Signs	4	<p>Contractor shall provide four Dynamic Roadside Information Displays (or signs) for the preferred locations as described in Exhibit D, Descriptions of Bus Stops for EDAPTS Test deployment.</p> <p>The display signs shall be continuously energized and easily readable by riders waiting at bus stops without any action on their part.</p> <p>The display signs shall be compliant with the Americans with Disabilities Act (ADA) requirements for the visually impaired as defined in the performance specification of this RFP and Federal.</p> <p>\$ _____ sign price</p> <p>\$ _____ sign Installation (Phase II)</p> <p>Contractor shall ensure that the University can expand the EDAPTS system by installing additional display signs at bus stops, as sufficient additional funding becomes available.</p>

Table 1: EDAPTS Components and Elements (Cont'd)

EDAPTS Components	Quantities	Descriptions
Roadside Data Communications System	1	<p>Contractor for the Bronco Express EDAPTS system shall consider three options for the Roadside Data Communications System:</p> <p>Option A: Dedicated RF voice/digital communications system</p> <p>Option B: Campus-wide Wi-Fi wireless communications system</p> <p>Option C: Public wireless network provider such as Verizon, Sprint, T-Mobile, etc.</p> <p>A comparison of the options in terms of performance, purchase price, installation cost and estimated on-going operating and maintenance costs shall be provided within the proposal. Contractor shall recommend a preferred approach and use the preferred approach within the submitted proposal. In the absence of other overriding concerns, the lowest lifecycle cost option that meets the performance needs specified in this RFP is the preferred methodology.</p> <p>Existing University WiFi Services can be found in Exhibit F, Descriptions of WiFi Services at Cal Poly Pomona.</p> <p>OPTION A: \$ _____</p> <p>OPTION B: \$ _____</p> <p>OPTION C: \$ _____</p>

Task 2 Installation and Preliminary Testing

Contractor shall install the EDAPTS components on Bronco Express shuttle buses, at the central site, dispatch centers of both the University and Service Provider, and at the specified bus stops.

Before installation, Contractor shall work with the Departments of Parking and Transportation Services (PTS) and Facilities Planning and Management, the Division of Instructional and Information Technology (I & IT), as well as the Service Provider to develop installation and preliminary testing plans. The University and Service Provider will identify, designate and make available representatives from these departments for the installation and testing.

Once the University and Service Provider approve the installation and testing plans, Contractor shall install all the equipment and software for the Bronco Express EDAPTS system and test the system as specified in the plans.

Contractor shall perform preliminary tests on all the EDAPTS equipment and software programs upon installation. Contractor shall provide the University with a test report showing acceptable performance after the testing is complete.

When Contractor requires civil engineering work (such as work on sign foundation, power supply, or access point) for installing roadside display signs, the preliminary test on display signs shall be conducted at the preferred locations suggested by the University. Contractor shall provide display signs' installation requirements and plans to the University and assist the University in developing an RFP for the specified civil engineering work for the EDAPTS system.

Phase II System Acceptance Test and 60-Day Research Evaluation

Task 3 System Acceptance Test and System Delivery

Contractor shall provide an Acceptance Test plan to the University for approval.

Contractor shall conduct an Acceptance Test in accordance with the approved plan and in coordination with University personnel. After successful completion of the acceptance test, the Contractor will officially deliver the Bronco Express EDAPTS system to the University.

Contractor shall provide all documents related to the installation, operation, and maintenance of the Bronco Express EDAPTS system. The documents shall include an Installation Manual and a User's Manual.

Task 4 60-Day Research Evaluation

Contractor shall provide sixty (60) days of operational assistance for the Bronco Express EDAPTS system. Once the installed system has successfully completed acceptance testing, Contractor shall assist the personnel from the Department of Parking and Transportation Services (PTS) to operate the EDAPTS system for the 60-day research evaluation period.

During the evaluation, Contractor shall document all the troubleshooting events, unexpected cases and solutions to any system and equipment problems. In addition, Contractor shall document and provide a report on operational performance, schedule adherence, and other significant operational events.

5.2 Warranty and Maintenance Service Contract

Contractor shall provide a time frame and any additional cost to extend manufacturers warranty period for equipment installed through this contract (Phase I) upon final testing and acceptance done in the installed environment to be accomplished in Phase II of this project.

\$ _____ Extended Manufacturer Warranty

Contractor shall offer a technical and maintenance service contract to the University to help the University to operate the EDAPTS system. These service contracts shall be for a minimum period of one year with options to extend the service contract for an additional four (5) years in one-year segments, commencing after warranty period. The University shall be able to exercise these optional services independently and in the sequence offered as long as the University has accepted the immediately preceding option offer.

Technical and Maintenance Service Contracts

- Year 1 \$ _____
- Year 2 \$ _____
- Year 3 \$ _____
- Year 4 \$ _____
- Year 5 \$ _____

5.3 Schedule, Milestones, and Deliverables

Contractor shall implement the Bronco Express EDAPTS system and provide the required deliverables under the schedule as shown in Table 2.

Table 2 Tasks, Schedules and Deliverables of the EDAPTS Test Deployment

Phase	Task	Deliverables	Complete Date	% of Contracted Payment
Phase I EDAPTS System Installation and Preliminary Testing	Task 1 <u>Provide EDAPTS System Components and Elements</u>	a) EDAPTS Components (including on-Board systems, Central Site Software (server), and roadside display signs) ready for the installation at Cal Poly Pomona b) Installation and Test Schedule	3/31/2008	60%
	Task 2 <u>Installation and Preliminary Testing</u>	a) Installation and Test Plans b) Installed EDAPTS system c) Preliminary Test Report	5/1/2008	75%

Phase	Task	Deliverables	Complete Date	% of Contracted Payment
Phase II System Acceptance Test and 60-Day Research Evaluation	<u>Task 3 System Acceptance Test and System Delivery</u>	<ul style="list-style-type: none"> a) Approved System Acceptance Testing Report b) Installation Manual c) User's Manuals d) Maintenance Service Contract 	10/15/2008	90%
	<u>Task 4 60-Day Research Evaluation</u>	60-Day Evaluation Report on operational performance, schedule adherence, and other significant operational events.	12/15/2008	100%

6. CONTRACTOR BID REQUIREMENTS

Contractors may respond to this RFP individually, in partnership or as a prime/subcontractor group. Where a partnership or group response is provided, the proposal shall designate a single prime contractor who is ultimately responsible for the overall manufacture, installation, testing, training and delivery of the Bronco Express EDAPTS system.

The University requires that all Contractor-proposed Bronco Express EDAPTS components described in Section 5 be integrated as an installed system for convenience and lower cost. The Contractor may: 1) choose to manufacture and supply all hardware, software, installation and services themselves, 2) procure all component hardware and software from a single external manufacturer and/or supplier, providing only installation and services themselves, or 3) purchase individual component hardware, software, installation and services from various manufacturers and/or suppliers and integrate it as the prime contractor. A more detailed description of the performance objectives can be found in Section 5, Scope of Work.

6.1 Contractor Deliverables

The successful contractor is responsible to deliver all hardware, software, training, documentation, installation, support, services, reports, test results, statements of completion, statements of EDAPTS compliance, etc. University shall receive all deliverables before the end of the project and prior to the Contractor receiving final payment.

6.2 Campus Contacts

Questions regarding scope of work or technical issues should be addressed to

Dr. Xudong Jia, P.E.,
Project Manager
Bronco Express EDAPTS Demo System Deployment
Civil Engineering Department
Cal Poly Pomona
909-869-4312
xjia@csupomona.edu

Questions regarding bidding requirement or contract issues should be addressed to:

Ms. Debra Garr
Procurement & Support Services
Cal Poly Pomona
909-869-3383 telephone
909-869-5475 fax
daschneck@csupomona.edu

6.3 Submittal Instructions

6.3.1 Submittal Location

Sealed proposals will be received at the Procurement and Support Services office on the Cal Poly Pomona campus until 5:00 PM on March 3, 2008. Late proposals will not be accepted. Faxed proposals will not be accepted.

For proposals sent through the United State Postal Service, submit to the following address:

3801 W. Temple Ave, Bldg. 75,
Pomona, CA 91768.

For proposals sent via FedEx or UPS, submit to the following address:

2740 S. Campus Drive, Bldg. 75,
Pomona, CA 91768.

All proposals must be in a sealed envelope clearly marked with “**RFP Number # 07-014, 3/3/08, 5:00 PM**”. Proposals received with broken seals may be rejected without evaluation at the discretion of the Evaluation Committee.

The respondents to this RFP may wish to deliver their proposal in person to assure these requirements are met. Cal Poly Pomona assumes no responsibility for delays caused by the United States Postal Service or the Cal Poly Pomona internal mail system.

6.3.2 Timeline

RFP Release Date	February 8, 2008
RFP Due Date	March 3, 2008
Award Date	March 10, 2008
Phase I Services to be completed	May 30, 2008

6.3.3 Proposal Package

Bidders shall submit seven (7) paper copies of their response to this RFP, each response in separately sealed package. An electronic PDF copy of the response to this RFP shall also be provided on CDROM.

6.3.3.1 Section 1 – Technical Proposal

The Proposal shall describe the contractor's approach and procedures to be used for the Scope of Work. Proposals shall be not more that 50 pages.

In the Technical Proposal, the Contractor shall have the following information:

- a) Title Page
- b) Table of Contents
- c) Transmittal Letter - The letter shall include the following:
 - a. Name of Contractor, including the name, address, email address, facsimile and telephone numbers, and tax identification number for contract purposes.
 - b. Discussion of the proposed working relationship between Contractor and any consultants and subcontractors who provide supplies and/or services that are 10% or greater of the total contract cost. In this case, name, address and telephone numbers of consultants and subcontractors shall be provided.
 - c. Acknowledgment of receipt of all RFP addenda, if any.
 - d. Name, title, address, telephone number, and e-mail address of the Contractors contact person for this project during the period of proposal evaluation. This will be used in the event of questions or issues needing clarification.

- e. A statement that the offer shall remain valid for a period of not less than one hundred eighty (180) days from the date of submittal of the proposal.
 - f. Name and signature of a person authorized to bind Contractor to the terms of the proposal and to negotiate contract price/terms on the Contractor's behalf.
- d) Team Organization and Qualifications - The project team establishes the ability of the Contractor to satisfactorily perform the required work described in the Scope of Work section. The proposal shall describe the project team from the viewpoint of experience in performing work of a similar nature; demonstrated competence in the services to be provided; strength and stability of the contractor and any consultants and subcontractors; staffing capability; work load; record of meeting schedules on similar projects and supportive client references. Prior experience in providing systems with similar requirements such as technical performance, size and complexity and the experience and technical competence of any consultants and subcontractors will be considered during evaluation.
- e) Work Related Experience - Contractor shall provide as a minimum three (3) references for the projects cited as related experience. For each cited work related experience project, the Contractor shall furnish the name, title, address and telephone number of the person(s) at the client organization who is most knowledgeable about the work performed by the Contractor.
- f) Other References and Information - Contractor may also wish to supply references from other work not cited in their response as related experience. Contractor should ensure contact names/telephone numbers are accurate, as inaccurate references may be a negative factor in the overall evaluation of the proposal. Each reference must specifically address the start and end dates of the project and a brief description of the products and/or services provided.
- g) Project Management and Key Personnel. The proposal shall discuss the Contractor's methodology to be used for managing the project work and any consultants and subcontractors. The proposal shall have the following information:
- a. Name and resume of the proposed Project Manager and all key personnel that will be assigned to the project. The assigned Project Manager shall be able to respond immediately to issues

relating to the project herein and shall have the corporate authority to do so. The Contractor shall discuss how this Project Manager's corporate authority will be ensured. The percent of time each key individual is dedicated to this project and a discussion of other potentially conflicting projects and the time allocated to them where applicable.

- b. A project organization chart clearly indicating all communication and reporting relationships among the project staff, consultants, subcontractors, and suppliers and their assigned project tasks.
- c. A statement that key personnel will be available to the extent proposed for the duration of the project and acknowledgment that individuals designated as "key personnel" on the project will not be removed or replaced without the prior written concurrence of the University.
- d. A description of the project management approach used to oversee consultants, subcontractors and suppliers, quality assurance, and quality control reporting on the project.
- h) Proposed Work Plan. The proposal shall provide a detailed narrative work plan and work schedule that addresses the Scope of Work section in this RFP. The proposal shall demonstrate that the Contractor understands the University's needs and requirements.
- i) Understanding of the Project The Contractor shall provide a brief statement of the improvements that are to be made (EDAPTS equipment, software, etc.), and the services that are to be provided (management, installation, testing, training, etc.), in the proposed Project. The proposal shall explain how the Contractor's proposal meets the University's goals for this project.
- j) Personnel Training The Contractor shall provide preliminary copies of training materials and shall provide a training schedule to the University demonstrating how personnel (i.e. drivers, dispatchers, mechanics and other support personnel) will be trained prior to the start-up of service operations.
- k) Testing and Acceptance Plan The Contractor shall include an outline of how the testing and acceptance procedures for all components, subsystems and processes will be structured. If available, the Contractor should provide copies of acceptance test documents for similar systems. The Contractor shall provide a proposed test schedule to the University demonstrating how the system will be

acceptance tested prior to the start-up of service operations. Additionally, the Contractor should provide a copy of its standard testing procedures and checklists used in development and testing of hardware, software and the documentation approach for recording test results.

- l) Proposed Plan for Documentation and Manual Standards The proposal shall provide 1) clear and complete documentation and manuals that describe how the EDAPTS system components and elements operate, and 2) training, operations and dispatch manuals that help the University operate the system after the system is officially delivered to the University.
- m) Warranty The proposal shall have a complete description of the warranty provided. This description shall include clear statements on the period of coverage, coverage limitations, and any parts, labor and/or shipping charges that may be applicable (see Section 5.2 of this RFP).
- n) Exceptions/Deviations The proposal may state any exceptions to or deviations from the requirements of this RFP, segregating "technical" exceptions from "contractual" exceptions. Each exception must reference the particular section in the Scope of Work that refers to the requirements of the Bronco Express EDAPTS system. If no clarification, exception or deviation is proposed by the Contractor, a statement to that effect shall be included in the proposal.
- o) Appendices Information that is considered by the Contractor to be pertinent to this project, but has not been specifically solicited the University in any of the aforementioned sections, may be placed in this appendix section. Contractors are cautioned, however, that this does not constitute an invitation to submit large amounts of extraneous material. Appendices should be relevant and brief.

6.3.3.2 Section 2 – Cost Proposal

The Cost Proposal shall provide costs for finishing all the tasks listed in the scope of work. There is no page limit on Cost Proposals.

In the Cost Proposal, the Contractor shall detail the costs in the following order:

- a) Equipment
- b) Labor - Including:

- a. Project Management,
 - b. System Installation,
 - c. Acceptance Testing,
 - d. Training,
 - e. Documentation and Manuals.
- c) Project Management – Including:
- a. Deliverables,
 - b. Program Plan,
 - c. General Project Management,
 - d. Bi-Monthly Status Reports and Schedule Updates,
 - e. Monthly Progress Review Meetings.
- d) Optional Maintenance and Service Agreement on a per year basis. The optional maintenance period starts after the Bronco Express EDAPTS system is officially delivered to the University
- a. Basic: Year 1
 - b. Extended: Years 2 through 5
- e) Non-covered Technical Support services for services provided after project acceptance. This shall be quoted as hourly rates for technical and engineering personnel. Quoted rates shall be valid for a period of 3 years after the Bronco Express EDAPTS system is officially delivered to the University. Any periodic adjustment of rates, based on projected out year cost changes, should be discussed along with justification for the changes projected.

The cost proposal shall include, distinguish and show all applicable charges, including:

- a) All direct and indirect costs necessary to fulfill the requirements of this contract, except as otherwise provided herein.
- b) All applicable taxes, including California State Sales Tax as appropriate.

7. EVALUATION OF PROPOSALS

7.1 General Discussion of Evaluation Process

All submitted proposals become the property of the University upon receipt. Information contained therein shall become public property subject to the California Public Records Act. The University reserves the right to make use of any information or ideas contained in the proposal unless specifically prohibited by Contractors “Proprietary” or “Restricted Use” notations within the proposal itself. (See Section 7.2: “Impact of Proprietary Data on Evaluation”)

The University reserves the right to accept or reject any proposals, any item or any part of a proposal, or to waive any informalities or irregularities in proposals where deemed appropriate by the University and/or the Evaluation Committee.

The University reserves the right to withdraw this RFP at any time without prior notice and the University makes no representations that any contract will be awarded to any bidder responding to this RFP.

The University will establish an Evaluation Committee to review and evaluate all submitted proposals. The Evaluation Committee will follow the evaluation scoring criteria described in Section 7.4 of this RFP, assign each proposal points and provide the University with a recommendation of a winning contractor. The University will determine whether to award a contract to the winning contractor for this project.

The University reserves the right to award this RFP to other than the lowest bidder based on an evaluation of best overall value to the University. All proposals received by the due date, time, irrespective of irregularities or informalities, will be opened, and the names of the bidders will be publicly read aloud at the Submittal Deadline. ***Notice: No other information regarding the evaluation and final award disposition of this RFP will be released until after the University makes a formal announcement regarding its intent to actually award a contract and names the successful contractor.***

7.2 Impact of Proprietary Data on Evaluation

This is a research project focused on making ITS solutions more accessible to small rural and urban transit agencies. Two of the primary objectives of the research are to 1) lower life-cycle cost by matching the ITS solution to the small transit operators environment, needs and budget and 2) to alleviate the negative impacts often encountered when suppliers provide solutions encumbered by

"proprietary data", "proprietary interfaces" and "proprietary designs". The EDAPTS concept is based on the premise that system expansion can be achieved subsequent to the initial installation (expansibility) through the purchase of compatible products and by using "open source" non-proprietary interface connections for the components, elements, hardware and software used in the system. Bidders who choose to restrict expansibility (and hence competition) through the use of proprietary information in their bids risk having their bid rejected or rated lower than other bidders who do not have such restrictions within their bid. This is especially true should those notations impact the interface connections between the various components and elements comprising the overall system.

7.3 Use of Direct or Indirect Research Support Funding

In some cases, a bidder may wish advance this research path by participating in this project. This participation may come in the form of reduced pricing, direct financial contributions to the research effort, donated material and/or donated labor, or some other type of "in kind" support. Any incorporation of these items into a Contractor's offer must be noted in the proposal. The University welcomes private sector research participation and will appropriately consider it during the evaluation process. The University will thoroughly review the legal implications of any offer of participation that may be presented by a Contractor. If the offer to participate appears to violate University policy or local, State or Federal laws and regulations regarding this procurement, that part of the proposal will be discounted and the proposal will be evaluated without considering the benefits of the participation offered.

7.4 Proposal Evaluation

To evaluate Bronco Express EDAPTS system proposals, the University will assemble an ad hoc committee, made up of experts from the University and other interested stakeholders. In addition to the written proposals, Contractors may be invited to make oral presentations to the University. If the University decides to pursue a contract award, the contractor determined to be the most highly qualified will be invited to enter final negotiations. If the most qualified firm is unable to consummate an agreement with the University, then the next most qualified contractor will be considered for award.

7.4.1 Evaluation Criteria

Contractors responding to this RFP will be evaluated based upon the following factors as presented in their proposal.

All submitted proposals will be ranked in the above eight described categories. Table 1 lists points assigned to each category.

Table 1 Evaluation Points for the Bronco Express EDAPTS System

Criteria	Points
1. Vehicle on-Board System and Vehicle Wireless Data Communications System	15
2. Advanced Transit Management System and Central Site Software (Server)	15
3. Open Source Software	5
4. No Software Licensing Fee	5
5. Installation & Testing	10
6. Warranty and Service Contracts	10
7. References and Experience	10
8. Cost	30
Maximum Total Points Available	100

8. CONTRACT NEGOTIATION

In the event there is a single Contractor who responds to this RFQ and said Contractor meets all the Vendor requirements, the University may choose to evaluate the costs proposed by the Contractor to determine if the costs are fair and reasonable. The Contractor shall be prepared to provide summaries of estimated costs (direct labor, fee, profit, overhead, other direct costs, etc.) and documentation supporting all cost elements. The University shall commence negotiations if the cost is determined to be fair and reasonable. In the event an agreement cannot be negotiated with the single Contractor, the University will terminate the negotiations and may re-solicit the RFP.

9. GENERAL PROVISIONS FOR SERVICE ACQUISITIONS

9.1 Commencement of Work

Work shall not commence on the proposed effort until 1) a fully executed contract has been received by the Contractor and 2) the Contractor has been given approval to proceed by the Cal Poly Pomona Contract Manager. Any work performed by the Contractor prior to the date of approval and/or authorization to proceed shall be considered as having been performed at the Contractor's own risk and as a volunteer without payment.

9.2 Invoices

9.2.1 Invoice Submittal

Invoices shall be submitted in arrears to the address stipulated in the Contract. The Contract number must be included on the invoice along with a unique invoice number or identifier. The final invoice shall be clearly marked as such.

9.2.2 Additional Services

In the event additional services are authorized by the Project Manager and performed by the Contractor, the Contractor shall submit invoices for such additional services in accordance with provisions herein.

9.2.3 Continuing Services

For work of a continuing nature, the Contractor shall submit invoices in arrears, upon completion of each task or portion of a task.

9.2.4 Payment Processing Delay

Unless otherwise specified, the University shall pay properly submitted invoices not more than 45 days after (i) the performance completion date of services; or (ii) receipt of an undisputed invoice, whichever is later. Late payment penalties shall not apply to this Contract.

9.2.5 Payment in Full

The consideration to be paid to the Contractor for work done under the contract and described within the contract document, shall be in full compensation for all

of Contractor's expenses incurred in the performance hereof, including travel and per diem, unless otherwise expressly so provided.

9.3 Contract Conditions and Limitations

9.3.1 Funding Appropriation

If the term of the Contract extends into fiscal years subsequent to that in which it is initially approved, such continuation of the Contract is subject to the appropriation of funds for such purpose by the State of California Legislature. If funds to effect such continued payment are not appropriated, Contractor agrees to:

- a) take back any commodities already furnished but not paid for under the Contract,
- b) terminate any services supplied to the University under the Contract, and
- c) relieve the University of any further obligation therefore.

9.3.2 Return of Commodities

University agrees that if Section 9.3.1 above is involved, commodities delivered but not paid for shall be returned to the Contractor in substantially the same condition in which they were delivered, subject to normal wear and tear. University further agrees to pay for packing, crating, transportation to Contractor's nearest facility and reimbursement for Contractor expenses incurred for assistance during such packing and crating.

9.4 Contract Cancellation

University reserves the right to cancel this Contract without penalty at any time with thirty (30) days prior written notice to the Contractor.

9.5 Independent Status

The Contractor, its agents and employees, shall act in an independent capacity in the performance of this Contract and not as officers, employees or agents of the University, the State of California or the United States government. While the Contractor may or may not be Base Package under the terms of this Contract to carry Worker's Compensation Insurance, the Contractor, its agents and

employees are not entitled to unemployment or workers' compensation benefits from the University, the State of California, or the United States government.

9.6 Conflict of Interest

The Contractor shall avoid the presence of or appearance of any conflict of interest.

9.6.1 Full Disclosure

Should the Contractor provide services for preparation or development of recommendations for the actions which are required, suggested or otherwise deemed appropriate, and which include the provision, acquisition or delivery of products or service; then the Contractor must provide full disclosure of any financial interest including but not limited to service Agreements, OEM, and/or remarketing Agreement that may foreseeable allow the Contractor to materially benefit from the adoption of such recommendations.

9.6.2 Statement of Economic Interests

The University requires a Statement of Economic Interests (Form 700) to be filed by any Contractor, Consultant or Subcontractor who is involved in the making, or participates in the making, of decisions that may foreseeably have a material effect on any University financial interest [reference G.C. 820191]

The University reserves the right to prohibit participation by the Contractor in bidding to or providing services, goods or supplies or any other related action which is required, suggested or otherwise deemed appropriate in the end product of this Contract.

9.7 Governing Law

To the extent not inconsistent with applicable federal law, this Contract shall be construed in accordance with and governed by the laws of the State of California.

9.8 Assignments

Without written consent of the University, the Contract is not assignable by Contractor either in whole or in part.

9.9 Time

Time is of the essence of the Contract.

9.10 Contract Alterations & Integration

No alteration or variation of the terms of the Contract shall be valid unless made in writing and signed by the authorized parties hereto, and no oral understanding or Contract not incorporated herein shall be binding on any of the parties hereto.

9.11 General Indemnity

The Contractor agrees to indemnify, defend and save harmless the University, the State of California, the United States Government, its officers, agents and employees from any and all claims and losses accruing or resulting to any other person, firm or corporation furnishing or supplying work, service, materials or supplies in connection with the performance of this Contract, and from any and all claims and losses accruing or resulting to any person, firm or corporation which may be injured or damaged by the Contractor in the performance of this Contract.

9.12 Use of Data

The Contractor shall not utilize any information not a matter of public record, which is received by reason of this Contract, for pecuniary gain not contemplated by the terms of this Contract, regardless of whether the Contractor is or is not under contract at the time such gain is realized. University specific information contained in the report, survey, or other product developed by the Contractor pursuant to this Contract is the property of the University, and shall not be used in any manner by the Contractor unless authorized by the University.

9.13 Termination for Default

The University may terminate the Contract and be relieved of the payment of any consideration to Contractor should Contractor fail to perform the covenants herein contained at the time and in the manner herein provided. In the event of such termination, the University may proceed with the work in any manner deemed proper by the University. The cost to the University shall be deducted from any sum due the Contractor under the Contract, and the balance, if any, shall be paid to the Contractor upon demand.

9.14 Personnel

The Contractor shall make every effort consistent with sound business practices to honor the specific requests of the University with regard to assignment of its employees; however, the Contractor reserves the sole right to determine the assignment of its employees. If a Contractor employee is unable to perform due to illness, resignation, or other factors beyond the Contractor's control, the Contractor shall make every reasonable effort to provide suitable substitute personnel with similar knowledge, skills, and abilities.

9.15 Nondiscrimination

Contractor shall not engage in the practice of discrimination, including but not limited to the following provisions:

9.15.1 Religion, Race, Ethnicity, Sex, Disability

During the performance of this contract, the Contractor, its consultants and its subcontractors shall not deny the Contract's benefits to any person on the basis of religion, color, ethnic group identification, sex, and age, physical or mental disability. Nor shall the Contractor discriminate unlawfully against any employee or applicant for employment because of race, religion, color, national origin, ancestry, physical handicap, mental disability, medical condition, marital status, age or sex. Contractor shall insure that the evaluation and treatment of employees and applicants for employment are free of such discrimination.

9.15.2 Fair Employment and Housing Act

The Contractor shall comply with the provisions of the Fair Employment and Housing Act (Government Code Section 12900 et seq.), the regulations promulgated hereunder (California Code of Regulations, Title 2, Sections 7285.0 et seq.), the provisions of Article 9.5, Chapter 1, Part 1, Division 3, Title 2 of the Government Code (Government Code Sections 11 135-1 1 139.5), and the regulations or standards adopted by the awarding state agency to implement such articles.

9.15.2.1 Access by Department of Fair Employment and Housing Personnel

The Contractor shall permit access by representatives of the Department of Fair Employment and Housing and the Trustees upon reasonable notice at any time during the normal business hours, but in no case less than 24 hours notice, to

such of its books, records, accounts, other sources of information, and its facilities as said Department or Trustees shall require to ascertain compliance with this clause.

9.15.2.2 Equal Opportunity/Affirmative Action

The provisions of Executive Order 11246, as amended (Equal Employment Opportunity/Affirmative Action), Section 402 of the Vietnam Era Veterans' Readjustment Assistance Act of 1974, as amended (38 U.S.C. 4212 or VEVRAA), and Section 503 of the Rehabilitation Act of 1973, as amended (29 U.S.C. 793), and the implementing regulations found at 41 CFR 60-1&2, 41 CFR 60-250, and 41 CFR 60-741, respectively, are hereby incorporated by reference.

9.15.2.3 Collective Bargaining Notification Obligations

The Contractor, its consultants and its subcontractors shall give written notice of their obligations under this clause to labor organizations with which they have a collective bargaining or other agreement.

9.15.2.4 Inclusion of Nondiscrimination Provisions

The Contractor shall include the nondiscrimination and compliance provisions of this clause in all subcontracts to perform work under the contract. (Gov. Code Section 12990, 11135 et seq.; Title 2, California Code of Regulations, Section 8107).

9.16 Drug-Free Workplace Certification

By accepting a contract or purchase order, the Contractor certifies under penalty of perjury under the laws of the State of California that the it will comply with the requirements of the Drug-Free Workplace Act of 1990 (Government Code, Section 8355 et. seq.) and will provide a drug-free workplace by doing all of that which Section 8355 et seq. require.

9.17 Severability

It is expressly agreed and understood by the parties hereto that if any provision of this Contract is held to be unconscionable or invalid under any applicable statute or rule of law, it is deemed to that extent to be omitted. However, the balance of the Contract shall remain in full force and effect.

9.18 Disputes

Any dispute arising under the terms of this Contract that is not resolved within a reasonable period of time by authorized representatives of the Contractor and the University shall be brought to the attention of the Chief Executive Officer (or designated representative) of the Contractor and the Chief Business Officer (or designee) of the University for joint resolution. At the request of either party, The University shall provide a forum for discussion of the disputed item(s), at which time the Vice Chancellor, Business and Finance (or designated representative) of the University shall be available to assist in the resolution by providing advice to both parties regarding the University's contracting policies and procedures. If resolution of the dispute through these means is pursued without success, either party may seek resolution employing whatever remedies exist in law or equity beyond this Contract. Despite an unresolved dispute, the Contractor shall continue without delay to perform its responsibilities under this Contract. In this event, the Contractor shall keep accurate records of its services in order to adequately document the extent of its services under this Contract.

9.19 Privacy of Personal Information

Contractor expressly acknowledges the privacy rights of individuals to their personal information, as expressed in the State's Information Practices Act (California Civil Code Section 1798 et seq.) and in California Constitution Article 1, Section 1. Contractor shall maintain the privacy of personal information. Contractor shall not release personal information contained in University records without full compliance with applicable state and federal privacy laws. Contractor further, acknowledges Federal privacy laws such as Gramm-Leach-Bliley Act (Title 15, United States Code, Sections 6801(b) and 6805(b)(2)) applicable to financial transactions and Family Educational Rights and Privacy Act (Title 20, United States Code, Section 1232g) applicable to student records and information from student records. Contractor shall maintain the privacy of protected personal information and shall be financially responsible, if and to the extent that any security breach relating to protected personal information results from acts or omissions of Contractor or its personnel, for any notifications to affected persons (after prompt consultation with the University), and to the extent requested by the University, shall be administratively responsible for such notification.

9.20 Waiver of Rights

Any action or inaction by the University or the failure of the University on any occasion to enforce any right or provision of the Contract shall not be construed

to be a waiver by the University of its rights hereunder, and shall not prevent the University from enforcing such provision or right on any future occasion. The rights and remedies of the University provided herein shall not be exclusive and are in addition to any other rights and remedies provided by law.

9.21 Endorsement

Nothing contained in this contract shall be construed as conferring on any party hereto, any right to use the other party's name as an endorsement of product/service or to advertise, promote or otherwise market any product or service without the express prior written consent of the other party. Furthermore, nothing in this Contract shall be construed as an endorsement of any commercial product or service by the University, its officers or employees.

9.22 Patent, Copyright, and Trade Secret Indemnity

A contractor may be required to furnish a bond to the University against any and all loss, damage, costs, expenses, claims and liability for copyright and trade secret infringement. In addition:

9.22.1 Legal Defense Against Claims

The Contractor, at its own expense, shall defend any action brought against the University, the State of California and the United States Government to the extent that such action is based upon a claim that the product supplied by the Contractor or the operation of such product infringes a United States patent or copyright or violates a trade secret. The Contractor shall pay those costs and damages finally awarded against the University in any such action. Such defense and payment shall be conditioned on the following:

- a) That the Contractor shall be notified within a reasonable time in writing by the University of any notice of such claim; and,
- b) That the Contractor shall have the sole control of the defense of any action on such claim and all negotiations for its settlement or compromise; provided, however, that when principles of government or public law are involved, the University has the option to participate in such action at its own expense.

9.22.2 Mitigation of Claim Violations

Should the product, or the operation thereof become, or in the Contractor's opinion is likely to become, the subject of a claim of infringement of a United States or foreign patent, copyright or trade secret, the University shall permit the Contractor at its option and expense to either:

- a) to procure for the University the right to continue using the product, or
- b) to replace or modify the same so that the product becomes non-infringing, provided such replacement or modified product satisfies the performance requirements specified in the Contract.

If none of these options can reasonably be taken, or if use of the delivered product by the University shall be prevented by injunction, the Contractor agrees to take back such product and make every reasonable effort to assist the University in procuring a substitute product. If, in the sole opinion of the University, the return of such infringing product makes the retention of other products acquired from the Contractor under this contract impractical, the University shall then have the option of terminating the contract, or applicable portions thereof without penalty or termination charge. The Contractor agrees to take back such product and refund any sums the University has paid Contractor less any reasonable amount for use or damage.

9.23 Compliance with NLRB Orders

Contractor declares under penalty of perjury that within the immediately preceding two-year period no more than one final, unappealable finding of Contempt of Court by a federal court has been issued against the Contractor due to the Contractor's failure to comply with an order of a federal court that ordered the Contractor to comply with an order of the National Labor Relations Board. This provision is required by, and shall be construed in accordance with, Public Contract Code Section 10296.

9.24 Examination and Audit

For contracts in excess of \$10,000, the Contractor shall be subject to the examination and audit of (1) the Office of the University Auditor, and (2) the State Auditor, for a period of three (3) years after final payment under the contract in accordance with Government Code Section 8546.7 and with Education Code Section 89045(c & d), respectively. The examination and audit shall be confined

to those matters connected with the performance of the contract, including, but not limited to, the costs of administering the Contract.

9.25 DVBE and Small Business Participation

The State of California supports statewide participation goals of 3% for disabled business enterprises, (DVBE Program) and requires agencies to provide a 5% preference when awarding contracts to small businesses. Only small businesses certified by the Office of Small Business and DVBE Services (OSDS) are eligible to receive the preference. The University encourages all contractors to use the services of DVBE and OSDS-certified small business enterprises whenever possible, and to report their use to the University.

9.26 Citizenship and Public Benefits

If Contractor is a natural person, Contractor certifies in accepting this Contract that s/he is a citizen or national of the United States or otherwise qualified to receive public benefits under the Personal Responsibility and Work Opportunity Reconciliation Act of 1996 (P.L. 104-193; 110 STAT.2105,2268-69).

9.27 Americans With Disabilities Act (ADA)

Contractor warrants that it complies with California and federal disabilities laws and regulations (28 CFR Part 36)

9.28 Child Support Compliance Act

For any contract in excess of \$100,000, the contractor acknowledges in accordance with Public Contract Code Section 71 10, that:

9.28.1 Child and Family Support Obligations

The contractor recognizes the importance of child and family support obligations and shall fully comply with all applicable state and federal laws relating to child and family support enforcement, including, but not limited to, disclosure of information and compliance with earnings assignment orders, as provided in Chapter 8 (commencing with Section 5200) of Part 5 of Division 9 of the Family Code.

9.28.2 Earnings Assignment Orders

The contractor, to the best of its knowledge, is fully complying with the earnings assignment orders of all employees and is providing the names of all new employees to the New Hire Registry maintained by the California Employment Development Department.

9.29 Document Referencing

All correspondence, invoices, bills of lading, shipping memos, packages, etc., must show the Contract number. If factory shipment, the factory must be advised to comply. Invoices not properly identified with the contract number and contractor identification number may be returned to contractor and may cause delay in payment.

9.30 Forced, Convict, Indentured and Child Labor

By accepting a contract or purchase order, the Contractor certifies that no apparel, garments or corresponding accessories, equipment, materials, or supplies furnished to the State pursuant to this Contract have been laundered or produced in whole or in part by sweatshop labor, or with the benefit of sweatshop labor, forced labor, convict labor, indentured labor under penal sanction, or abusive forms of child labor or exploitation of children in sweatshop labor. Contractor shall cooperate fully in providing reasonable access to the Contractor's records, documents, agents or employees, or premises if reasonably required by authorized officials of the University, the Department of Industrial Relations, or the Department of Justice determine the Contractor's compliance with the requirements above. (Public Contract Code Section 6108)

9.31 Covenant Against Gratuities

The Contractor shall warrant that no gratuities (in the form of entertainment, gifts, or otherwise) were offered or given by the Contractor, or any agent or representative of the Contractor, to any officer or employee of the University with a view toward securing the Contract or securing favorable treatment with respect to any determinations concerning the performance of the Contract. For breach or violation of this warranty, the University shall have the right to terminate the Contract, either in whole or in part, and any loss or damage sustained by the University in procuring on the open market any items which the Contractor agreed to supply shall be borne and paid for by the Contractor. The rights and remedies of the University provided in this clause shall not be exclusive and are

in addition to any other rights and remedies provided by law or under the Contract.

9.32 Rights and Remedies of University for Default

9.32.1 Failure to Perform as Required

In the event any deliverables furnished or services provided by the Contractor in the performance of this Contract should fail to conform to the requirements herein, or to the sample submitted by the Contractor, the University may reject the same, and it shall thereupon become the duty of the Contractor to reclaim and remove the same forthwith or to correct the performance of services, without expense to the University, and immediately to replace all such rejected items with others conforming to such specifications or samples; provided that should the Contractor fail, neglect, or refuse to do so, the University shall thereupon have the right to purchase in the open market, in lieu thereof; a corresponding quantity of any such items and to deduct from any moneys due or that may thereafter become due to the Contractor the difference between the price named in the Contract and the actual cost thereof to the University.

9.32.2 Failure to Deliver Promptly

In the event the Contractor shall fail to make prompt delivery as specified of any item, the same conditions as to the right of the University to purchase in the open market and to reimbursement set forth above shall apply, except for *force majeure* as described below. Except for defaults of subcontractors, neither party shall be responsible for delays or failures in performance resulting from acts beyond the control of the offending party. Such acts (known as "*force majeure*") shall include but shall not be limited to fire, strike, freight embargo or acts of God and of the Government. If a delay or failure in performance by the Contractor arises out of a default of its subcontractor, and if such default arises out of causes beyond the control of both the Contractor and subcontractor and without the fault or negligence of either of them, the Contractor shall not be liable for damages of such delay or failure, unless the supplies or services to be furnished by the subcontractor were obtainable from other sources in sufficient time to permit the Contractor to meet the required performance schedule.

9.32.3 Termination Loss or Damage Recovery

In the event of the termination of the Contract, either in whole or in part, by reason of the default or breach thereof by the Contractor, any loss or damage

sustained by the University in procuring any items which the Contractor therein agreed to supply shall be borne and paid for by the Contractor.

9.32.4 Other Rights and Remedies

The rights and remedies of the University provided above shall not be exclusive and are in addition to any other rights and remedies provided by law or under the Contract.

9.33 Contractor's Power and Authority

The Contractor warrants that it has full power and authority to grant the rights herein granted and will hold the University hereunder harmless from and against any loss, cost, liability, and expense (including reasonable attorney fees) arising out of my breach of this warranty. Further, Contractor avers that it will not enter into any arrangement with any third party that might abridge any rights of the University under this Contract.

9.34 Recycled Content Certification

Contractor agrees to certify in writing, under penalty of perjury, the minimum, if not the exact, percentage of recycled content material, as defined in Sections 12161 and 12200 of the Public Contract Code, in materials, goods, or supplies used in the performance of this Contract.

9.35 Entire Contract

This Contract sets forth the entire agreement between the parties with respect to the subject matter hereof and shall govern the respective duties and obligations of the parties.

9.36 Safety and Accident Prevention

In performing work under this Contract on University premises, Contractor shall conform to any specific safety requirements contained in the Contract or as required by law or regulation. Contractor shall take any additional precautions as the University may reasonably require for safety and accident prevention purposes. Any violation of such rules and requirements, unless promptly corrected, shall be grounds for termination of this Contract in accordance with default provisions hereof.

9.37 Follow-On Contracts

If the Contractor or its affiliates provides Consulting and Direction, as defined below, the Contractor and its affiliates will not act as consultant to any person or entity that does receive a Contract described in sub-section below. This prohibition will continue for one (1) year after termination of this Contract or completion of the Consulting and Direction, whichever comes later.

9.37.1 "Consulting and Direction" Defined

For the purposes of this contract, "Consulting and Direction" means services for which the Contractor received compensation from the University and includes:

- a) development of or assistance in the development of work statements, specifications, solicitations, or feasibility studies;
- b) development or design of test requirements;
- c) evaluation of test data;
- d) direction of or evaluation of another Contractor;
- e) provision of formal recommendations regarding the acquisition of products or services; or
- f) Provisions of formal recommendations regarding any of the above.

9.37.2 "Affiliates" Defined

For purposes of this contract, "affiliates" are employees, directors, partners, joint venture participants, parent corporations, subsidiaries, or any other entity controlled by, controlling, or under common control with the Contractor. Control exists when an entity owns or directs more than fifty percent (50%) of the outstanding shares or securities representing the right to vote for the election of directors or other managing authority.

9.37.3 Exclusions

Except as prohibited by law, the restrictions of this Section will not apply:

- a) to follow-on advice given by vendors of commercial off-the-shelf products, including Software and Hardware, on the operation, integration, repair, or maintenance of such products after sale; or

- b) where the University has entered into a contract for software or services and the scope of work at the time of Contract execution expressly calls for future recommendations among the Contractor's own products.

9.38 Expatriate Corporations

By accepting a contract or purchase order, the Contractor declares under penalty of perjury under the laws of the State of California that the Contractor is eligible to contract with the University pursuant to The California Taxpayer and Shareholder Protection Act of 2003, Public Contract Code Section 10286 et. Seq.

9.39 Insurance Requirements

Contractor shall furnish to the University prior to the commencement of work an underwriter's endorsement with a certificate of insurance stating that there is General Liability insurance presently in effect for the contractor with a combined single limit of not less than \$1,000,000 per occurrence, and \$2,000,000 aggregate; and that vehicle insurance (where applicable) is in effect with a minimum coverage of \$1,000,000 per occurrence.

9.39.1 Certificate of Insurance Contents

The certificate of insurance shall provide the University with assurance that:

- a) the insurer will not cancel the insured's coverage without thirty (30) days prior notice to the University;
- b) the State of California, the Trustees of the California State University, the University, the campus, and the employees, volunteers, officers, and agents of each of them, are included as additional insured's, but only insofar as the operations under this contract are concerned;
- c) the State, the Trustees, and the University, and the employees, officers, and agents of each of them will not be responsible for any premiums or assessments on the policy;
- d) the insurer has an AM Best rating of "A: VII" or equivalent.

9.39.2 Bodily Injury Coverage

The Contractor shall provide bodily injury liability insurance as indicated herein, and that said insurance shall be in effect at all times during the term of this

contract. In the event insurance coverage expires at any time or times during the term of this contract, contractor agrees to provide at least thirty (30) days prior to expiration date and provide the University with a new Certificate of Insurance. The new certificate shall provide evidence of insurance coverage as provided herein for not less than the remainder of the term of the contract or for a period of not less than one (1) year.

All Certificates of Insurance are subject to the approval of the University and the contractor agrees that no work or services shall be performed prior to the giving of such approval. In the event contractor fails to keep in effect at all times insurance coverage as herein provided, the University may in addition to any other remedies it may have, terminate this contract at no penalty upon the occurrence of such event.

9.39.3 Workers Compensation Insurance

The contractor shall provide Workers' Compensation Insurance coverage as required by the State of California.

9.40 Rights in Work Product

All inventions, discoveries, intellectual property, technical communications and records originated or prepared by the Contractor pursuant to this Contract including papers, reports, charts, computer programs, and other Documentation or improvements thereto, and including Contractor's administrative communications and records relating to this Contract (collectively, the "Work Product"), shall be Contractor's exclusive property. The provisions of this subsection may be revised in a Statement of Work

9.40.1 Software Rights

Software and other materials developed or otherwise obtained by or for Contractor or its mates independently of this Contract or applicable purchase order ("Pre-Existing Materials") do not constitute Work Product. If Contractor creates derivative works of Pre-Existing Materials, the elements of such derivative works created pursuant to this Contract constitute Work Product, but other elements do not. Nothing in this Clause will be construed to interfere with Contractor's or its affiliates' ownership of Pre-Existing Materials.

9.40.2 Government Purpose Rights

The University will have Government Purpose Rights to the Work Product as Deliverable or delivered to the University hereunder. "Government Purpose Rights" are the unlimited, irrevocable, worldwide, perpetual, royalty-free, non-exclusive rights and licenses to use, modify, reproduce, perform, release, display, create derivative works from, and disclose the Work Product. Government Purpose Rights also include the right to release or disclose the Work Product outside the University for any University purpose and to authorize recipients to use, modify, reproduce, perform, release, display, create derivative works from and disclose the Work Product for any University purpose. Such recipients of the Work Product may include, without limitation, University Contractors, California State government, California local governments, the U.S. federal government, and the State and local governments of other states. Government Purpose Rights do not include any rights to use, modify, reproduce, perform, release, display, create derivative works from, or disclose the Work Product for any commercial purpose.

9.40.3 Development Of Competitive Products

The ideas, concepts, know-how, or techniques relating to data processing developed during the course of this Contract by the Contractor or jointly by the Contractor and the State may be used by either party without obligation of notice or accounting. This Contract shall not preclude the Contractor from developing materials outside this Contract that are competitive, irrespective of their similarity to materials which might be delivered to the State pursuant to this Contract.

9.41 Confidentiality of Data

All financial, statistical, personal, technical and other data and information relating to University's operation which are designated confidential by the University and not otherwise subject to disclosure under the California Public Records Act, and made available to the Contractor in order to carry out this Contract, or which become available to the Contractor in carrying out this Contract, shall be protected by the Contractor using the same level of care in preventing unauthorized disclosure or use of the confidential information that it takes to protect its own information of a similar nature, but in no event less than reasonable care. The Contractor shall not be required under the provisions of this clause to keep confidential any data or information that is or becomes publicly available, is already rightfully in the Contractor's possession, is independently developed by the Contractor outside the scope of this Contract, or is rightfully obtained from third parties.

RFP # 07-014
California State Polytechnic University, Pomona
SIGNATURE PAGE
Bronco Express EDAPTS System

TO: Debra Garr
Procurement & Support Services
Cal Poly Pomona
3801 W. Temple Ave, Bldg. 75
Pomona, CA 91768

In accordance with your Request for Proposal # 07-014; Bronco Express EDAPTS System, this proposal is submitted for your evaluation.

Company Name

Address	City	State	Zip Code
---------	------	-------	----------

Phone Number

Fax Number

Printed Name of Official Authorized to Submit This Offer

Signature of Official

Date Signed

Title of Official

Federal ID Number

- 10. EXHIBIT A: EDAPTS SYSTEM REQUIREMENTS AND PERFORMANCE SPECIFICATIONS**
- 11. EXHIBIT B: EDAPTS DATA FORMATTING STANDARDS**
- 12. EXHIBIT C: CAL POLY POMONA EDAPTS TEST DEPLOYMENT OPERATIONS DESCRIPTIONS**
- 13. EXHIBIT D: DESCRIPTIONS OF BUS STOPS FOR EDAPTS TEST DEPLOYMENT**
- 14. EXHIBIT E: SAMPLE REPORTS**
- 15. EXHIBIT F: DESCRIPTIONS OF WIFI SERVICES AT CAL POLY POMONA**



EDAPTS
Smart Transit System



RFP 07-014

Exhibit A

Cal Poly Pomona
EDAPTS Test Deployment
**EDAPTS System Requirements
and
Performance Specification**

Prepared for
California Partners for Advanced Transit and Highways
California Department of Transportation

Prepared by

Xudong Jia, Ph.D., P.E
California State Polytechnic University, Pomona

and

Jeff Gerfen
California Polytechnic State University, San Luis Obispo

Under PATH Contract TO 6403

June 8, 2007

EDAPTS Performance Specification

A. Report Summary

1. Selected System Functionality

Vehicle On-Board Systems: The equipment and software installed in a transit vehicle to perform transit management functions. On-Board systems will typically include a Mobile Data Terminal and associated peripherals such as magnetic stripe card readers, on-board annunciators and electronic message signs, and driver's emergency button.

- Display time of day to driver
- Display current stop schedule adherence to driver
- Automatically collect and record boardings & alightings counts
- Provide notification of stop arrivals and departures to driver
- Collect route number during login
- Provide real-time vehicle updates (location, schedule adherence, etc)
- Survey stop locations
- Blank screen while bus is moving
- Display time-until-departure at current stop
- Receive, store, and transfer bus stop data from peripheral on-board devices
- Collect driver ID during login
- Change driver's work assignment during the day
- Declare on board emergency
- Manually collect and record passenger boarding counts.

Dynamic Roadside Information Display: An electronic, remotely controlled display that presents information regarding estimated time of arrival of buses to passengers waiting at bus stops. These displays typically provide "real-time" information based upon bus progress along route.

- Provide estimated time until arrival to passengers at stops
- Provide dynamic public service information to passengers at stops

Advanced Transit Management System: The software application that will run at locations such as the dispatch center and other management offices, typically providing personnel with information such as vehicle position and location, schedule adherence data, boarding and ridership data, and statistical analysis and reporting of the above functions.

- Provide geolocation tracking display of transit vehicles for dispatch & management users
- Display passenger boarding / alighting information for dispatch & management users
- Provide statistical ridership reports for dispatch & management users
- Display schedule adherence information for dispatch & management users
- Handle driver emergency button alarms for dispatch and management users
- Provide statistical schedule adherence reports for dispatch & management users

- Provide controls for roadside banner message display
- Provide system user administration

Central Site Software: The software that will run at a fixed, central location to receive, transmit, store, and facilitate the exchange of data between other components. Such software typically provides an interface to communicate with On-Board and Roadside components, stores and retrieves collected system data, and provides Application Programming Interfaces (APIs) to both ATRMS and Traveler Information systems.

- Provide API for transit traveler information

2. Required Components and Elements

Vehicle On-Board Systems

- **Mobile Data Terminal (MDT)**: A device that provides the driver access to various functions such as schedule adherence status, passenger boarding status, time of day, time of day, route being driven. The MDT provides driver input and output functions and is likely connected to other on-board elements.
- **MDT Functional Processes**: Software that executes on the MDT to perform functions such as detecting bus stops, accepting data from devices such as an Automatic Passenger Counter or a media reader, or controlling on-board devices such as annunciators and electronic display signs.
- **MDT Vehicle Wireless Data Communications System Driver**: Software that executes on the MDT interface to the Vehicle Wireless Data Communications System. This software may perform data encoding/decoding.
- **APC (Automatic Passenger Counter)**: Devices mounted at all bus entry and exit locations that detect passengers embarking and disembarking from the bus. APCs typically keep track of the total number of people riding on the bus at any given time. Data may be downloaded at the end of the day or may be transferred to another on-board devices such as the MDT as it is determined.
- **Emergency Actuator**: A device that drivers will utilize to send an emergency notification or "Mayday" message to the dispatcher indicating they have a situation on their bus which poses a physical threat to themselves or any of the passengers. The Emergency Actuator would typically be installed in the driver's compartment so that the driver could actuate it unbeknownst to anyone else on the bus.

Vehicle Wireless Data Communications System

- **On-Board High-Speed Data Interface**: An on-board device, such as a modem or data communications card, that allows the on-board computational equipment (the MDT) to make a high-speed data communications connection to the central site from within the transit facility.
- **On-board High-Speed Communications Infrastructure / Repeaters**: Equipment located on the transit facility that serves as a relay station for high-speed bi-directional wireless data communications transmissions between the central site and transit vehicle on-board systems in the transit facility.
- **Central-Site High-Speed Data Interface**: A device such as a modem, data communications card, or network access card that allows the central site communications servers to make a high-speed wireless data connection to transit On-Board Systems of transit vehicles within the transit facility.

- On-Board Wide-Area Wireless Data Interface: An on-board device, such as a modem or data communications card, that allows the on-board computational equipment (the MDT) to make a data communications connection to the central site from anywhere in the transit service area.
- On-board Wide-Area Communications Infrastructure / Repeaters: Equipment located on mountaintops, buildings, poles, etc. that serves as a relay station for bi-directional wireless data communications transmissions between the central site and buses anywhere in the transit service area.
- Central-Site Wide-Area Wireless Data Interface: A device such as a modem, data communications card, or network access card that allows the central site communications servers to make a connection to transit vehicle on-board systems anywhere in the transit service area via the Wireless Communications system.

Dynamic Roadside Information Display

- Roadside Sign / Display: A device (typically installed on a post or pole) that presents "live" data regarding estimated time of arrival or minutes until arrival for transit vehicles arriving at a stop. This sign/display may display information for more than one route at a given stop and also may display other messages such as public service announcements or system status information.
- Roadside Post: A post or pole that supports the Roadside Information Display.
- Roadside Post Foundation: The foundation for the Roadside Post.
- RID Functional Processes: Software that executes on the RID and receives messages from the central site and performs functions such as calculating estimated minutes for arrival for buses, formatting public service messages for display.
- RID Communications System Driver: Software that executes on the RID and interfaces to the RID Data Communications System. This software may perform data encoding/decoding.

Roadside Data Communications System

- Roadside Data Interface: A device, such as a modem, data communications card, or network access card that allows the Dynamic Roadside Information Display to make a data communications connection to the central site.
- Roadside Communications Infrastructure / Repeaters: Equipment located on mountaintops, buildings, poles, etc. that is serves a relay station for uni-directional or bi-directional wireless data communications transmissions between Roadside Information Displays and the central site.
- Central-Site Data Interface: A device such as a modem, data communications card, or network access card that allows the central site communications servers to make a data communications connection to buses via the On-Board Wireless Communications system.

Advanced Transit Management System

- On-Board Equipment Administration Controls: A GUI screen with controls that allows a management user to administer the MDT computer and its operating system remotely from the central site. Administration capabilities include loading new configuration files, software executables, system schedules / timetables, and retrieving log files of various system functions. These administration tools give the remote administrator the same tools they would have if they were connected into the MDT's operating system via a hard-wire connection.

- Schedule Management & Administration Tools & Controls: A GUI screen with controls that allows a management user to build, modify, or delete system schedules on a per time period, per route, or per system basis.
- ATRMS Data Communications System Driver: Software that executes on the ATRMS interface to the ATRMS Communications System. This software may perform data encoding/decoding.
- Driver Management Controls: A GUI screen with controls that allows the addition, removal, and editing of drivers and driver information within the system.
- Emergency Management Display: A GUI screen that alerts a dispatch and/or management user when a driver has depressed his or her emergency actuator. This screen creates audible and visible indications of the emergency conditions and does not allow any other activity on any ATRMS console until the emergency has been acknowledged and coordination responsibility is assumed by a dispatch or management user. It enables continuous "live" tracking of the vehicle reporting the emergency and allows the emergency to be closed out and automatically logged when it is over.
- Roadside Information Display Controls: A GUI screen with controls that allows a management user to reconfigure Roadside Information Displays to serve different stops, update their schedules, or update them with public service or system status banner messages.
- Vehicle Tracking Display: A GUI screen with controls that allows a dispatch and/or management user to observe real-time vehicle positions. The screen may display information in a map-based or tabular form, depending upon specific user requirements.
- Schedule Adherence Display: A GUI screen with controls that allows a dispatch or management user to observe vehicle schedule adherence on a user-defined per stop, per trip, per route, per hour, or per day basis.
- Passenger Boardings Display: A GUI screen with controls that allows a dispatch and/or management user to observe passenger boardings on a user-defined per stop, per trip, per route, per hour, or per day basis.
- Ridership Statistics Reporting Controls: A GUI screen with controls that allows a dispatch or management user to generate reports regarding ridership statistics on a user-defined per stop, per trip, per route, per hour, or per day basis.
- Schedule Adherence Statistics Reporting Controls: A GUI screen with controls that allows a dispatch or management user to generate reports regarding vehicle schedule adherence on a user-defined per stop, per trip, per route, per hour, or per day basis. Reports generated may be either statistical or exception based in nature.
- System User Management Controls: A GUI screen with controls that allows a management user to create new system users, modify the permissions of existing users, or delete users.

ATRMS Communications

- ATRMS / Central-Site Data Interfaces: The local area networking (LAN) cards installed in central-site workstations and servers.
- ATRMS Communications Infrastructure / Repeaters: The local area networking (LAN) equipment used to connect central-site workstations and servers to each other and to remote ATRMS clients via the Internet.

Central Site Software

- On-Board Systems API: A software application that runs at the central site and communicates with all Mobile Data Terminals (MDTs) in the fleet via the Central Site Wireless Data Interface and the On-Board Communications Infrastructure and Repeaters. This communications server provides all access to Mobile Data Terminals in vehicles for the central site.
- ATRMS API: A software application that runs at the central site and provides a set of functions that return information to support all ATRMS GUI screens.
- Data Store: A software application or function (most likely a dbms) that provides short term and long term storage of all system data received from transit vehicles and system schedules.
- Data Store API: An application programmers interface that provides read-write access to the Data Store for software applications such as the Central Site Software and the ATRMS.
- CSS Functional Processes: Software that executes at the central site to perform functions such as calculating schedule adherence, processing driver emergencies, generating reports, managing schedules, etc.
- CSS Vehicle Wireless Data Communications Systems Driver: Software that executes at the central site and interfaces to the Vehicle Wireless Data Communications System. This software may perform data encoding/decoding.
- CSS ATRMS Data Communications System Driver: Software that executes at the central site and interfaces to the ATRMS Communications System. This software may perform data encoding/decoding.
- Roadside Information Display API: A software application that runs at the central site and communicates with all Roadside Information Displays via the Central Site Data Interface and the Roadside Communications Infrastructure and Repeaters. This communications server provides all access to Roadside Information Displays for the central site.
- CSS RID Data Communications System Driver: Software that executes at the central site and interfaces to the RID Communications System. This software may perform data encoding/decoding.
- Traveler Information API: A software application that runs at the central site and provides a set of functions that return information regarding vehicle location on route, schedule adherence, and vehicle seat availability to applications that will provide this information the public through various communications and display schemes.

System Input Data

- Stop-Point List: The master list of all stops in the transit system. Each stop has a unique identifier number or designation as well as latitude, longitude, and direction of travel for the stop. It may also include other identification information such as common street names, intersection and/or stop name.
- Timetable: The master schedule for the transit system, indicating all routes, trips, and stops on trips in the system.
- Work / Runs List: The master list of all runs in the system.
- Valid Drivers List: A list of valid transit fleet drivers.

3. Market Packages

- ITS Data Mart: This market package provides a focused archive that houses data collected and owned by a single agency, district, private sector provider, research institution, or other organization. This focused archive typically includes data covering a single transportation mode and one jurisdiction that is collected from an operational data store and archived for future use. It provides the basic data quality, data privacy, and meta data management common to all ITS archives and provides general query and report access to archive data users.
- Transit Vehicle Tracking : This market package monitors current transit vehicle location using an Automated Vehicle Location System. The location data may be used to determine real time schedule adherence and update the transit system's schedule in real-time. Vehicle position may be determined either by the vehicle (e.g., through GPS) and relayed to the infrastructure or may be determined directly by the communications infrastructure. A two-way wireless communication link with the Transit Management Subsystem is used for relaying vehicle position and control measures. Fixed route transit systems may also employ beacons along the route to enable position determination and facilitate communications with each vehicle at fixed intervals. The Transit Management Subsystem processes this information, updates the transit schedule and makes real-time schedule information available to the Information Service Provider.
- Transit Fixed-Route Operations : This market package performs vehicle routing and scheduling, as well as automatic operator assignment and system monitoring for fixed-route and flexible-route transit services. This service determines current schedule performance using AVL data and provides information displays at the Transit Management Subsystem. Static and real time transit data is exchanged with Information Service Providers where it is integrated with that from other transportation modes (e.g. rail, ferry, air) to provide the public with integrated and personalized dynamic schedules.
- Transit Passenger and Fare Management : This market package manages passenger loading and fare payments on-board transit vehicles using electronic means. It allows transit users to use a traveler card or other electronic payment device. Sensors mounted on the vehicle permit the operator and central operations to determine vehicle loads, and readers located either in the infrastructure or on-board the transit vehicle allow electronic fare payment. Data is processed, stored, and displayed on the transit vehicle and communicated as needed to the Transit Management Subsystem. Two other market packages, ATMS10: Electronic Toll Collection and ATMS16: Parking Facility Management also provide electronic payment services. These three market packages in combination provide an integrated electronic payment system for transportation services.

- Transit Security : This market package provides for the physical security of transit passengers and transit vehicle operators. On-board equipment is deployed to perform surveillance and sensor monitoring in order to warn of potentially hazardous situations. The surveillance equipment includes video (e.g., CCTV cameras), audio systems and/or event recorder systems. The sensor equipment includes threat sensors (e.g., chemical agent, toxic industrial chemical, biological, explosives, and radiological sensors) and object detection sensors (e.g., metal detectors). Transit user or transit vehicle operator activated alarms are provided on-board. Public areas (e.g., transit stops, park and ride lots, stations) are also monitored with similar surveillance and sensor equipment and provided with transit user activated alarms. In addition this market package provides surveillance and sensor monitoring of non-public areas of transit facilities (e.g., transit yards) and transit infrastructure such as bridges, tunnels, and transit railways or bus rapid transit (BRT) guideways. The surveillance equipment includes video and/or audio systems. The sensor equipment includes threat sensors and object detection sensors as described above as well as, intrusion or motion detection sensors and infrastructure integrity monitoring (e.g., rail track continuity checking or bridge structural integrity monitoring).

The surveillance and sensor information is transmitted to the Emergency Management Subsystem, as are transit user activated alarms in public secure areas. On-board alarms, activated by transit users or transit vehicle operators are transmitted to both the Emergency Management Subsystem and the Transit Management Subsystem, indicating two possible approaches to implementing this market package.

In addition the market package supports remote transit vehicle disabling by the Transit Management Subsystem and transit vehicle operator authentication.

- Transit Traveler Information: This market package provides transit users at transit stops and on-board transit vehicles with ready access to transit information. The information services include transit stop annunciation, imminent arrival signs, and real-time transit schedule displays that are of general interest to transit users. Systems that provide custom transit trip itineraries and other tailored transit information services are also represented by this market package.
- Mayday and Alarms Support : This market package allows the user (driver or non-driver) to initiate a request for emergency assistance and enables the Emergency Management Subsystem to locate the user, gather information about the incident, and determine the appropriate response. The request for assistance may be manually initiated or automated and linked to vehicle sensors. This market package also includes general surveillance capabilities that enable the Emergency Management Subsystem to remotely monitor public areas (e.g., rest stops, parking lots) to improve security in these areas. The Emergency Management Subsystem may be operated by the public sector or by a private sector telematics service provider.

- Evacuation and Reentry Management : This market package supports evacuation of the general public from a disaster area and manages subsequent reentry to the disaster area. The market package addresses evacuations for all types of disasters, including disasters like hurricanes that are anticipated and occur slowly, allowing a well-planned orderly evacuation, as well as disasters like terrorist acts that occur rapidly, without warning, and allow little or no time for preparation or public warning.

This market package supports coordination of evacuation plans among the federal, state, and local transportation, emergency, and law enforcement agencies that may be involved in a large-scale evacuation. All affected jurisdictions (e.g., states and counties) at the evacuation origin, evacuation destination, and along the evacuation route are informed of the plan. Information is shared with traffic management agencies to implement special traffic control strategies and to control evacuation traffic, including traffic on local streets and arterials as well as the major evacuation routes. Reversible lanes, shoulder use, closures, special signal control strategies, and other special strategies may be implemented to maximize capacity along the evacuation routes. Transit resources play an important role in an evacuation, removing many people from an evacuated area while making efficient use of limited capacity. Additional shared transit resources may be added and managed in evacuation scenarios. Resource requirements are forecast based on the evacuation plans, and the necessary resources are located, shared between agencies if necessary, and deployed at the right locations at the appropriate times.

Evacuations are also supported by EM10, the "Disaster Traveler Information" market package, which keeps the public informed during evacuations. See that market package for more information.

- Disaster Traveler Information: This market package uses ITS to provide disaster-related traveler information to the general public, including evacuation and reentry information and other information concerning the operation of the transportation system during a disaster. This market package collects information from multiple sources including traffic, transit, public safety, emergency management, shelter provider, and travel service provider organizations. The collected information is processed and the public is provided with real-time disaster and evacuation information using ITS traveler information systems.

A disaster will stress the surface transportation system since it may damage transportation facilities at the same time that it places unique demands on these facilities to support public evacuation and provide access for emergency responders. Similarly, a disaster may interrupt or degrade the operation of many traveler information systems at the same time that safety-critical information must be provided to the traveling public. This market package keeps the public informed in these scenarios, using all available means to provide information about the disaster area including damage to the transportation system, detours and closures in effect, special traffic restrictions and allowances, special transit schedules, and real-time information on traffic conditions and transit system performance in and around the disaster.

This market package also provides emergency information to assist the public with evacuations when necessary. Information on mandatory and voluntary evacuation zones, evacuation times, and instructions are provided. Available evacuation routes and destinations and current and anticipated travel conditions along those routes are provided so evacuees are prepared and know their destination and preferred evacuation route. Information on available transit services and traveler services (shelters, medical services, hotels, restaurants, gas stations, etc.) is also provided. In addition to general evacuation information, this market package provides specific evacuation trip planning information that is tailored for the evacuee based on origin, selected destination, and evacuee-specified evacuation requirements and route parameters.

This market package augments the ATIS market packages that provide traveler information on a day-to-day basis for the surface transportation system. This market package provides focus on the special requirements for traveler information dissemination in disaster situations.

B. Specification Details

1. System-Wide Requirements

1.1.1. Documentation

1.1.1.1. Document writing level

Metric Requirement: All documents shall be presented clearly and concisely, and reflect writing of at least a 12th grade level.

Verification Method: Verify writing level.

1.1.1.2. Document reading comprehension level

Metric Requirement: All documents shall be clearly understandable by audiences with 12th grade reading comprehension level.

Verification Method: Inspect deliverable documents to ensure compliance.

1.1.1.3. Document clarity

Metric Requirement: All documents shall conform to the MIL-STD-962D documentation standard, section 4.7 for clarity.

Verification Method: Verify conformance with standard.

1.1.1.4. Document style

Metric Requirement: All documents shall conform to the U.S. Government Printing Office Style Manual for style and grammar.

Verification Method: Verify conformance with standard.

1.1.1.5. Document wiring diagrams identifiers

Metric Requirement: All cables and wires on wiring diagrams shall utilize unique identifiers which match physical labels on cables.

Verification Method: Inspect deliverables to ensure compliance.

1.1.1.6. Document wiring diagrams inter page connections

Metric Requirement: All wiring diagram inter-page connections shall be clearly marked at the left or right hand side of the page with the wire or cable's unique identifier.

Verification Method: Inspect deliverables to ensure compliance.

1.1.1.7. Document wiring diagram individual signals

Metric Requirement: All wiring diagrams shall reflect individual signal levels for multi-conductor cables.

Verification Method: Inspect deliverables to ensure compliance.

1.1.1.8. Document wiring diagrams standard connections

Metric Requirement: System wiring diagrams shall indicate all individual conductors/signals by unique identifier

Verification Method: Inspect deliverables to ensure compliance.

1.1.1.9. System manual theory

Metric Requirement: The System Manual shall include a Theory of Operation outlining the operation of the system and how it functions.

Verification Method: Verify conformance with standard.

1.1.1.10. System manual comprehensiveness

Metric Requirement: The System Manual shall be comprehensive and cover all system-operation scenarios in clear step-by-step detail.

Verification Method: Verify document comprehensiveness.

1.1.1.11. System manual troubleshooting

Metric Requirement: The System Manual shall include clear step-by-step instructions for troubleshooting any potential system problems.

Verification Method: Verify troubleshooting procedures and completeness.

1.1.1.12. System manual installation documentation

Metric Requirement: The System Manual shall include clear step-by-step instructions for installing the EDAPTS system.

Verification Method: Verify troubleshooting procedures and completeness.

1.1.1.13. System manual maintenance instructions

Metric Requirement: The System Manual shall include clear step-by-step instructions for all necessary routine or scheduled maintenance procedures.

Verification Method: Verify troubleshooting procedures and completeness.

1.1.1.14. Operator manual comprehensiveness

Metric Requirement: The User Manual shall be comprehensive and cover all user-operation scenarios in clear step-by-step detail.

Verification Method: Verify document comprehensiveness.

1.1.1.15. Operator manual troubleshooting

Metric Requirement: The User Manual shall include clear step-by-step instructions for troubleshooting common potential problems.
Verification Method: Verify troubleshooting procedures and completeness.

1.1.2. Functional Performance

1.1.2.1. Supported vehicle quantity

Metric Requirement: The minimum number of vehicles supported by the system shall be the specified number plus 50%.
Units of Measurement: Vehicles
Value: 8
Verification Method: Verify in system design document or specifications. Inspect deliverables to ensure compliance.

1.1.2.2. Supported sign quantity

Metric Requirement: The minimum number of Dynamic Roadside Information Displays supported by the system shall be the specified number plus 50%.
Units of Measurement: Signs
Value: 4
Verification Method: Verify in system design document or specifications. Inspect deliverables to ensure compliance.

1.1.2.3. Supported run quantity

Metric Requirement: The minimum number of scheduled runs supported by the system shall be the specified number plus 50%.
Units of Measurement: Runs
Value: 12
Verification Method: Verify in system design document or specifications. Inspect deliverables to ensure compliance.

1.1.2.4. Supported route quantity

Metric Requirement: The minimum number of scheduled routes supported by the system shall be the specified number plus 50%.
Units of Measurement: Routes
Value: 3
Verification Method: Verify in system design document or specifications. Inspect deliverables to ensure compliance.

1.1.2.5. Supported trip quantity

Metric Requirement: The minimum number of scheduled trips supported by the system shall be the specified number plus 50%.
Units of Measurement: Trips

Value: 225
Verification Method: Verify in system design document or specifications. Inspect deliverables to ensure compliance.

1.1.2.6. Supported stop quantity

Metric Requirement: The minimum number of stops supported by the system shall be the specified number plus 50%.
Units of Measurement: Stops
Value: 33
Verification Method: Verify in system design document or specifications. Inspect deliverables to ensure compliance.

1.1.2.7. Supported driver quantity

Metric Requirement: The minimum number of drivers supported by the system shall be the specified number plus 50%.
Units of Measurement: Drivers
Value: 30
Verification Method: Verify in system design document or specifications. Inspect deliverables to ensure compliance.

1.1.2.8. Supported farecard quantity

Metric Requirement: The minimum number of passenger farecards supported by the system shall be the specified number plus 50%.
Units of Measurement: Fare Cards
Value: 50000
Verification Method: Verify in system design document or specifications. Inspect deliverables to ensure compliance.

1.1.3. Human Factors

1.1.3.1. Ease of use ALL

Metric Requirement: All devices displaying information to or requiring information from a user shall be easy to use and display clear operational usage instructions to the user
Verification Method: Verify in system design document or specifications. Inspect deliverables to ensure compliance.

1.1.4. Installation & Maintenance

1.1.4.1. Element installability

Metric Requirement: All system elements shall be installable by qualified transit property personnel.
Verification Method: Test installation to ensure compliance.

1.1.4.2. Element part availability

- Metric Requirement: The transit property shall have the ability to self-maintain all system Elements due to the availability of spare parts and the capability to retain a supply of spares.
- Verification Method: Verify in vendor's contract documents.

1.1.5. Manufacturing

1.1.5.1. Part edge trueness

- Metric Requirement: Any non-radiused external part edges shall be smooth, straight, and true.
- Verification Method: Verify in system design document or specifications. Inspect deliverables to ensure compliance.

1.1.5.2. Part corners

- Metric Requirement: All installed physical parts shall have smoothed (radiused / non-sharp) corners.
- Verification Method: Verify in system design document or specifications. Inspect deliverables to ensure compliance.

1.1.5.3. Part physical tolerances

- Metric Requirement: All physical parts shall be manufactured to within the given tolerance of their specified dimensions.
- Units of Measurement: Inches
- Value: 0.005
- Verification Method: Verify in system design document or specifications. Inspect deliverables to ensure compliance.

1.1.5.4. Part interchangeability

- Metric Requirement: All parts having the same manufacturer's part number are functionally and physically interchangeable.
- Verification Method: Verify in system design document or specifications. Inspect deliverables to ensure compliance.

1.1.5.5. Part availability

- Metric Requirement: All system elements and their associated parts shall have a reasonable expectation of being available for a minimum period of five years.
- Verification Method: Verify availability in supply contract.

1.1.5.6. Part corrosion resistance

Metric Requirement: All external metal parts and exposed fasteners shall be corrosion resistant.

Verification Method: Verify in system design document or specifications. Inspect deliverables to ensure compliance.

1.1.5.7. Part emi transmission

Metric Requirement: All installed parts shall meet FCC guidelines and licensing as appropriate and shall meet MIL-STD-461 tolerances for radiated emissions.

Units of Measurement: Specifications

Value: TRUE

Verification Method: Inspect supplied certifications.

1.1.5.8. Abrasion resistance OBS

Metric Requirement: All installed cables shall utilize cable clamps, split loom, cable raceways, or other similar methods to minimize cable abrasion along the length of the cable.

Verification Method: Inspect deliverables to ensure compliance.

1.1.6. Privacy & Security

1.1.6.1. Rider ID privacy

Metric Requirement: Raw passenger fare or pass identification numbers or strings that directly identify a specific rider may not be stored anywhere in the EDAPTS system or transmitted across any EDAPTS communications link. Any obfuscation method of these numbers must be one-way and non-reversible, preventing the transformation back to a raw ID number or string.

Verification Method: Verify in system design document or specifications. Test installation to ensure compliance.

1.1.6.2. Driver ID privacy

Metric Requirement: Driver's identification numbers or strings containing sensitive personal information such as social security numbers shall not be stored anywhere in the EDAPTS system or transmitted across any EDAPTS communications link.

Verification Method: Verify in system design document or specifications. Test installation to ensure compliance.

1.1.6.3. Network attack resistance

Metric Requirement: All EDAPTS components utilizing a TCP/IP connection for communication shall be resistant to compromise by common network attacks such as spoofing and packet flooding (DDOS).

Verification Method: Verify in system design document or specifications. Inspect deliverables to ensure compliance.

1.1.6.4. Communications link attack resistance

Metric Requirement: ALL EDAPTS components utilizing a wireless communications link shall encode, encrypt, or otherwise protect communications against snooping or unauthorized use. Such protection shall meet or exceed common industry best practices.

Verification Method: Verify in system design document or specifications. Inspect deliverables to ensure compliance.

1.1.7. Ruggedness & Reliability

1.1.7.1. Operational lifecycle

Metric Requirement: The expected lifecycle of EDAPTS system elements shall exceed the specified number of years.

Units of Measurement: Years

Value: 7

Verification Method: Inspect manufacturer certification

1.1.7.2. Mayday message reliability

Metric Requirement: Mayday messages initiated by the driver shall be received with the specified percent reliability.

Units of Measurement: Percent

Value: 100

Verification Method: Verify in system design document or specifications. Test installation to ensure compliance.

1.1.7.3. Weather resistance

Metric Requirement: All EDAPTS elements installed in an outdoor environment shall be weather resistant to the installed environment.

Verification Method: Inspect manufacturer certification

1.1.7.4. Data corruption resistance

Metric Requirement: All EDAPTS elements shall be resistant to corruption of data due to power loss, shock, or other external forces.

Verification Method: Inspect manufacturer certification

1.1.7.5. Data retention

Metric Requirement: On-Board System elements shall maintain configuration and calibration information in memory for a minimum number of days while powered off.
Units of Measurement: Days
Value: 180
Verification Method: Inspect manufacturer certification

1.1.7.6. Power loss recovery

Metric Requirement: All EDAPTS elements shall be able to recover from a power loss and resume normal operations without requiring specialized technical interaction.
Verification Method: Inspect manufacturer certification

1.1.7.7. Operating environment max ambient temperature

Metric Requirement: All outdoor or vehicle-installed EDAPTS elements shall operate in ambient temperatures up to the specified maximum.
Units of Measurement: Degrees Farenheit
Value: 120
Verification Method: Inspect manufacturer certification

1.1.7.8. Operating environment max induced temperature

Metric Requirement: All outdoor or vehicle-installed EDAPTS elements shall operate in induced temperatures (include allowances for the effects of solar heating) up to the specified maximum.
Units of Measurement: Degrees Farenheit
Value: 160
Verification Method: Inspect manufacturer certification

1.1.7.9. Operating environment min temperature

Metric Requirement: All outdoor or vehicle installed EDAPTS elements shall operate in temperatures down to the specified minimum.
Units of Measurement: Degrees Farenheit
Value: -24
Verification Method: Inspect manufacturer certification

1.1.7.10. Operating environment max humidity

Metric Requirement: All outdoor or vehicle-installed EDAPTS elements shall operate at relative humidity levels up to the specified maximum.
Units of Measurement: Percent
Value: 100
Verification Method: Inspect manufacturer certification

1.1.7.11. Contaminant protection

Metric Requirement: All outdoor or vehicle-installed EDAPTS elements shall protect against external contaminants such as dust, salt air, and fog as necessary to prevent interruption of operation.

Verification Method: Inspect manufacturer certification

1.1.7.12. Operational lifetime

Metric Requirement: All EDAPTS elements shall operate for a minimum number of years before expected replacement.

Units of Measurement: Years

Value: 7

Verification Method: Inspect manufacturer certification

1.1.8. Standards & Practices

1.1.8.1. Product marking

Metric Requirement: All installed parts shall bear a manufacturer's nameplate or sticker, containing the manufacturer's name, product part number and revision as applicable, and serial number.

Verification Method: Inspect deliverables to ensure compliance.

1.1.8.2. Cable standards

Metric Requirement: All field-installed interface wires and cables shall use suitable gauge, shielding, and color for the application in conformance with applicable SAE and state and federal DOT standards.

Verification Method: Verify in system design document or specifications. Inspect deliverables to ensure compliance.

1.1.8.3. Cable marking

Metric Requirement: All installed interconnect cables shall bear a cable marker at six inches from each end of the cable, and at regular intervals along the cable.

Verification Method: Inspect deliverables to ensure compliance.

1.1.8.4. Null values

Metric Requirement: Null values shall be used when initializing or creating any data or data types, or recording an out-of-range value.

Verification Method: Verify in system design document or specifications. Test deliverables to ensure compliance.

1.1.8.5. Workmanship

Metric Requirement: All equipment and accessories shall be a product of good workmanship and shall be free from any defects that will affect their appearance or serviceability.

Verification Method: Inspect deliverables to ensure compliance.

1.1.8.6. Equipment commonality

Metric Requirement: All installed equipment shall share Component-level part commonality, allowing for ease of swappage or replacement with minimal reconfiguration.

Verification Method: Verify in system design document or specifications. Inspect deliverables to ensure compliance.

1.1.8.7. Hardware commonality

Metric Requirement: All user or maintenance accessible hardware (including mounting hardware) shall share Component-level part commonality, and also at the system-wide level where possible.

Verification Method: Verify in system design document or specifications. Inspect deliverables to ensure compliance.

1.1.8.8. Specification conflicts

Metric Requirement: In case of conflict between regulatory body, classification and international regulations and requirements, and this specification, the more stringent requirement shall take precedence.

Verification Method: Verify in system design document or specifications.

1.1.8.9. Data transparency

Metric Requirement: All data transferred between subsystems or components shall be left in an uncompressed, unencoded, or unencrypted form, except as needed for reasons such as security or passage through low-throughput communications links. In instances where compression, encoding, or encryption is deemed necessary, documentation shall be provided describing the compression / encoding / encryption algorithms required and fully detailing the implementation used.

Verification Method: Verify in system design document or specifications and upon system delivery.

1.1.8.10. Data validation

Metric Requirement: All transferred data between elements or components shall be validated upon receipt and before use to eliminate out-of-range and non-sensical values.

Verification Method: Verify in system design document or specifications or inspect supplied certifications

1.1.8.11. Data corruption

Metric Requirement: All transferred data between EDAPTS Components shall include a checksum or other similar method to test for data corruption, and shall be tested for such corruption upon receipt.

Verification Method: Verify in system design document or specifications or inspect supplied certifications

1.1.8.12. Data structure extensibility

Metric Requirement: If extension of an EDAPTS protocol is deemed necessary, it shall be done in a manner that does not interfere or break compatibility with existing data elements, and shall not duplicate or otherwise repeat existing functionality.

Verification Method: Verify in system design document or specifications or inspect supplied certifications

1.1.8.13. Software programming languages

Metric Requirement: All vendor-developed software shall be written in an industry standard, high level, non-proprietary language.

Verification Method: Verify in system design document or specifications or inspect supplied certifications

2. Vehicle On-Board Systems

2.1. General Requirements

2.1.1. Human Factors

2.1.1.1. Inobtrusiveness OBS

Metric Requirement: On-board devices shall not impede driver's view of the road, normal driver operations, movement in the driver's or passenger compartments, nor entry or egress from the vehicle.

Verification Method: Test installation to ensure compliance.

2.1.2. Installation & Maintenance

2.1.2.1. Removal and replacement OBS

Metric Requirement: The maximum amount of time required to remove and replace an On-Board system element.

Units of Measurement: Minutes

Value: 10 minutes

Verification Method: Test installation to ensure compliance.

2.1.2.2. Self diagnostics OBS

Metric Requirement: The On-Board systems shall provided self-test diagnostics to aid in fault isolation.

Verification Method: Verify in system design document or specifications. Test installation to ensure compliance.

2.1.3. Mechanical Interfacing

2.1.3.1. Mounting hole pattern tolerances OBS

Metric Requirement: All On-Board System element mounting hole patterns shall be manufactured to within the given tolerance of their specified dimensions.

Units of Measurement: Inches

Value: 0.005

Verification Method: Inspect deliverables to ensure compliance.

2.1.3.2. Mounting hole size tolerances OBS

Metric Requirement: All On-Board System element mounting hole dimensions shall be manufactured to within the given tolerance of their specified dimensions.

Units of Measurement: Inches

Value: 0.005

Verification Method: Inspect deliverables to ensure compliance.

2.1.4. Power

2.1.4.1. Over current protection OBS

Metric Requirement: All power connections shall be fused or circuit breaker protected at the source connection.

Verification Method: Verify in system design document or specifications. Inspect deliverables to ensure compliance.

2.1.5. Ruggedness & Reliability

2.1.5.1. Emi resistance OBS

Metric Requirement: On-Board System elements shall be resistant to levels of EMI present in a commercial environment.

Verification Method: Inspect manufacturer certification

2.1.5.2. Mtbf OBS

Metric Requirement: The expected MTBF of On-Board system elements shall exceed the specified number of hours.

Units of Measurement: Hours

Value: 7,500

Verification Method: Inspect manufacturer certification

2.1.5.3. Physical shock resistance OBS

Metric Requirement: On-Board System elements shall not be negatively affected by physical shocks and impacts present in a commercial transit environment.

Verification Method: Inspect manufacturer certification

2.1.5.4. Vibration resistance OBS

Metric Requirement: On-Board System elements shall not be negatively affected by the vibrations in a commercial transit environment.

Verification Method: Inspect manufacturer certification

2.1.5.5. Contaminant protection OBS

Metric Requirement: On-Board System elements shall be resistant to external contaminants such as dust, salt air, and fog to prevent interruption of operation.

Verification Method: Inspect manufacturer certification

2.1.6. Safety & Certification

2.1.6.1. Dot certification OBS

Metric Requirement: All On-Board Systems elements shall meet all applicable state and federal DOT standards.

Verification Method: Inspect supplied certifications

2.1.6.2. Fcc licensing OBS

Metric Requirement: All On-Board Systems elements utilizing wireless transmission for inter-element data transfer shall be provided with necessary FCC licenses for operation in the transit system.

Verification Method: Inspect supplied certifications

2.1.6.3. Ewra compliance OBS

Metric Requirement: All On-Board Systems elements shall be compliant with the California Electronic Waste Recycling Act of 2003.

Verification Method: Inspect supplied certifications

2.2. Mobile Data Terminal (MDT)

2.2.1. Communications & Electrical Interfacing

2.2.1.1. Interfacing MDT

Metric Requirement: For its wired electrical control/data interfaces, the MDT shall be able to connect to other on-board peripherals and other equipment using easy to remove connectors or terminals.

The MDT control/data signal interfaces shall be interference-tolerant in a production bus environment. Control/data interface signal levels shall be fully defined, non-proprietary and easily accessible to other connecting on-board peripherals and equipment. Control/data signal interfaces shall utilize commonly accepted standards and protocols such as SAE J1708, RS232, TCIP, IEEE, etc. Signal structures used (levels, timing, etc.) shall be compatible with data needs.

Verification Method: Verify in vendor's specifications

2.2.2. Computational Hardware

2.2.2.1. User input responsiveness MDT

Metric Requirement: The maximum amount of time the MDT shall take to respond to driver or passenger input for normal (non-emergency) operations.

Units of Measurement: Seconds

Value: 1

Verification Method: Test by timing user operations.

2.2.2.2. Memory capacity MDT

Metric Requirement: The MDT shall have sufficient memory capacity to handle transit system operational parameters as given in this specification.

Verification Method: Verify in vendor specifications.

2.2.2.3. Storage capacity MDT

Metric Requirement: The MDT shall have necessary non-volatile storage capacity to sustain operations with all necessary transit system operation parameter maximums as given in this specification.

Verification Method: Verify in vendor specifications.

2.2.2.4. Logging capacity MDT

Metric Requirement: The MDT shall have the necessary non-volatile storage capacity to store all collected stop data for the minimum specified period.

Units of Measurement: Days

Value: 30

Verification Method: Verify in vendor specifications.

2.2.2.5. Logging capacity CSS

Metric Requirement: The Central Site Software shall have the necessary non-volatile storage capacity to store all collected data for the greater of either the specified value or given transit provider requirement.

Units of Measurement: Years

Value: 1

Verification Method: Verify in vendor specifications.

2.2.2.6. Processing capacity media reader MDT

Metric Requirement: The Mobile Data Terminal shall be capable of validating, logging, and forwarding to the central site the specified number of pass-card media reads per minute.

Units of Measurement: Pass-card reads per minute

Value: 50

Verification Method: Verify in vendor specifications and inspect deliverables to ensure compliance

2.2.2.7. Processing capacity APC MDT

Metric Requirement: The Mobile Data Terminal shall be capable of logging and forwarding to the central site the specified number of counts per minute.

Units of Measurement: APC counts per minute

Value: 50

Verification Method: Verify in vendor specifications and inspect deliverables to ensure compliance

2.2.2.8. Latency emergency actuator MDT

Metric Requirement: The Mobile Data Terminal shall be capable of detecting an emergency actuator signal from the driver and transmitting the message to the central dispatch site within the specified number of seconds.

Units of Measurement: Seconds

Value: 2 seconds

Verification Method: Verify in vendor specifications.

2.2.2.9. Processing capacity MDT

Metric Requirement: The Mobile Data Terminal shall be capable of validating, logging, and forwarding to the central site the specified number of vehicle location and status per minute.

Units of Measurement: Location updates per minute

Value: 2

Verification Method: Verify in vendor specifications and inspect deliverables to ensure compliance

2.2.3. Design & Architecture

2.2.3.1. Extensibility MDT

Metric Requirement: The MDT shall support additional on-board APTS applications in software and hardware.

Units of Measurement: Applications

Value: 2

Verification Method: Verify in vendor specifications.

2.2.3.2. Extensibility OBS API

Metric Requirement: Future modifications to the OBS API shall be possible and shall not affect existing functionality.

Verification Method: Verify in API documentation.

2.2.4. Functional Performance

2.2.4.1. Power switch MDT

Metric Requirement: The MDT shall have an accessible power switch in the driver's compartment.

Verification Method: Verify in system design document or specifications. Inspect deliverables to ensure compliance.

2.2.4.2. Time of day clock MDT

Metric Requirement: The MDT shall have a large format clock to display time to the driver when the coach is in motion
Verification Method: Verify in system design document or specifications. Test installation to ensure compliance.

2.2.4.3. Stop arrival display MDT

Metric Requirement: The MDT shall display bus stop name to the driver upon arrival at a stop.
Verification Method: Verify in system design document or specifications. Test installation to ensure compliance.

2.2.4.4. Schedule adherence display MDT

Metric Requirement: The MDT shall display bus stop arrival schedule adherence information to the driver when at a stop
Verification Method: Verify in system design document or specifications. Test installation to ensure compliance.

2.2.4.5. Departure countdown display MDT

Metric Requirement: The MDT shall display countdown until departure in minutes to a driver while at a stop or on break.
Verification Method: Verify in system design document or specifications. Test installation to ensure compliance.

2.2.4.6. Bus pass validation MDT

Metric Requirement: The MDT shall validate bus pass data presented by the Pass / Fare media reader, validate the data, and indicate if it is valid or invalid to the driver and the rider who presented the pass to the media reader.
Verification Method: Verify in system design document or specifications. Test installation to ensure compliance.

2.2.4.7. Process APC counts MDT

Metric Requirement: The MDT shall receive APC boarding and alighting data from the APC, display a cumulative count to the driver, associate this data with stops during the day, and incorporate the data into the stop record transmitted to the central site for each stop.
Verification Method: Verify in system design document or specifications. Test installation to ensure compliance.

2.2.4.8. Receive undetermined data MDT

Metric Requirement: The MDT shall have the capability to receive data from yet to be determined on-board devices, associate this data with stops, and transmit it to the central site upon departure from a stop.

Verification Method: Verify in system design document or specifications.

2.2.4.9. Control annunciator MDT

Metric Requirement: The MDT shall have the capability to control an on-board annunciator to notify passengers upon arrival at a stop, departure from a stop, and when travelling between stops.

Verification Method: Verify in system design document or specifications. Test installation to ensure compliance.

2.2.4.10. Control electronic sign MDT

Metric Requirement: The MDT shall have the capability to control an on-board electronic sign to notify passengers upon arrival at a stop, departure from a stop, and when travelling between stops.

Verification Method: Verify in system design document or specifications. Test installation to ensure compliance.

2.2.4.11. Detect arrivals & departures MDT

Metric Requirement: The MDT shall have the capability to detect arrivals and departures from stops, when at a stop, and when between stops based on the transit schedule and master stop list.

Verification Method: Verify in system design document or specifications. Test installation to ensure compliance.

2.2.4.12. Prompt for driver MDT

Metric Requirement: The MDT shall have the capability to prompt a driver for their ID number upon login, and then associate the ID number with an ID number / name cross reference in the MDT.

Verification Method: Verify in system design document or specifications. Test installation to ensure compliance.

2.2.4.13. Prompt for route number MDT

Metric Requirement: The MDT shall have the capability to prompt a driver for route number upon login.

Verification Method: Verify in system design document or specifications. Test installation to ensure compliance.

2.2.4.14. Route change MDT

Metric Requirement: The MDT shall have the capability to prompt the driver for a route number during a route change during the day.

Verification Method: Verify in system design document or specifications. Test installation to ensure compliance.

2.2.4.15. Log boarding data MDT

Metric Requirement: The MDT shall have the capability to log boarding and alighting data for retrieval and post processing.

Verification Method: Verify in system design document or specifications. Test installation to ensure compliance.

2.2.4.16. System administration MDT

Metric Requirement: The MDT shall have the capability to be remotely administered from the central site.

Verification Method: Verify in system design document or specifications. Test installation to ensure compliance.

2.2.4.17. Log arrival departure data MDT

Metric Requirement: The MDT shall have the capability to log stop departure and arrival data for retrieval and post processing.

Verification Method: Verify in system design document or specifications. Test installation to ensure compliance.

2.2.4.18. Declare on board emergency MDT

Metric Requirement: The MDT shall have the capability to declare on-board emergencies to central dispatch and then send regular position updates to the central site.

Verification Method: Verify in system design document or specifications. Test installation to ensure compliance.

2.2.4.19. Survey stops MDT

Metric Requirement: The MDT shall have the capability to survey route stops for latitude, longitude, and direction (heading).

Verification Method: Verify in system design document or specifications. Test installation to ensure compliance.

2.2.4.20. Admin data comm MDT

Metric Requirement: The MDT shall have the capability to communicate with the central site to support administrative functions such as software updates, schedule downloads, and retrieval of data logged on the MDT.

Verification Method: Verify in system design document or specifications. Test installation to ensure compliance.

2.2.4.21. Self test MDT

Metric Requirement: The MDT shall have the capability to perform a comprehensive self-test upon power up.

Verification Method: Verify in system design document or specifications. Test installation to ensure compliance.

2.2.4.22. Commanded diagnostics MDT

Metric Requirement: The MDT shall have the capability to perform self-test and diagnostics of other on-board devices upon a command from the MDT front panel (user interface).

Verification Method: Verify in system design document or specifications. Test installation to ensure compliance.

2.2.4.23. Receive vehicle faults MDT

Metric Requirement: The MDT shall have the capability to receive mechanical malfunction reporting from the driver for a bus.

Verification Method: Verify in system design document or specifications. Test installation to ensure compliance.

2.2.5. Human Factors

2.2.5.1. Ergonomics accessibility MDT

Metric Requirement: The MDT controls and interface shall be easily operable by the driver without requiring a significant shift from driving position.

Verification Method: Test installation to ensure compliance.

2.2.5.2. Ergonomics readability MDT

Metric Requirement: The MDT display shall be clearly readable by the driver from its installation location as he or she conducts normal operations. The MDT display shall maintain clear readability under both day and night-time conditions.

Verification Method: Test installation to ensure compliance.

2.2.5.3. Ergonomics audibility MDT

Metric Requirement: All sounds, tones, or other audible feedback generated by the MDT shall be of sufficient volume to be audible in the driver's compartment above background vehicle noise.

Verification Method: Test installation to ensure compliance.

2.2.5.4. Ergonomics ease of use MDT

Metric Requirement: The MDT shall provide a simple, easy to use, uncluttered interface to the driver. All commonly used actions such as log-in, log-out, and route-change shall be easily accessible and provide integrated step-by-step instructions. Buttons and screen controls shall be easily used and activated.

Verification Method: Verify in system design document or specifications. Test installation to ensure compliance.

2.2.5.5. Ergonomics driver interaction MDT

Metric Requirement: The MDT shall require minimal interaction by the driver as during normal driver operations.

Verification Method: Verify in vendor specifications.

2.2.6. Power

2.2.6.1. Supply power dissipation maximum MDT

Metric Requirement: Maximum power dissipation allowable by the device.

Units of Measurement: Watts

Value: 30

Verification Method: Verify in vendor's specifications

2.2.6.2. Supply voltage range MDT

Metric Requirement: Voltage ranges the device must be able to operate under.

Units of Measurement: Volts DC

Value: 9 to 32

Verification Method: Verify in vendor's specifications

2.2.6.3. Supply allowable noise MDT

Metric Requirement: The Mobile Data Terminal shall conform to the SAE J1455 standard, section 4.11.2 for transients and noise ranges the device must be able to operate under.

Verification Method: Verify conformance with standard.

2.2.7. Ruggedness & Reliability

2.2.7.1. Stop detection reliability MDT

Metric Requirement: The MDT shall detect stops with the specified percent reliability when GPS is available.

Units of Measurement: Percent

Value: 99.5

Verification Method: Verify in system design document or specifications. Test installation to ensure compliance.

2.2.8. Safety & Certification

2.2.8.1. Coach in motion MDT

Metric Requirement: The Mobile Data Terminal shall detect when the vehicle is in motion, and shall blank its screen to prevent driver distraction. Display of the time in large characters is acceptable.

Verification Method: Verify in system design document or specifications. Test deliverables to ensure compliance.

2.2.9. System Accuracy

2.2.9.1. Georeference accuracy MDT

Metric Requirement: Latitude and longitude estimates shall be accurate to within the specified number of meters.

Units of Measurement: Meters

Value: 10

Verification Method: Inspect supplied certifications

2.2.9.2. Time reporting accuracy MDT

Metric Requirement: Time estimates shall be accurate within the specified number of seconds.

Units of Measurement: Seconds

Value: 1

Verification Method: Test deliverables to ensure compliance or inspect supplied certifications

2.2.9.3. Time synchronization MDT

Metric Requirement: If any time measurement is utilized, it shall be synchronized with Coordinated Universal Time (UTC), and maintain accuracy within the specified number of seconds

Units of Measurement: Seconds

Value: 1

Verification Method: Inspect supplied certifications

2.3. MDT Functional Processes

2.3.10. Data Formatting

2.3.10.1. Data format MDT functional processes

Metric Requirement: The MDT functional processes shall transfer data to and from the MDT Vehicle Wireless Data Communications System Driver in accordance with the EDAPTS Data Formatting Standard.

Verification Method: Verify documented data formats in system design documents or specifications.

2.4. MDT Vehicle Wireless Data Communications System Driver

2.4.11. Documentation

2.4.11.1. Interface documentation MDT comm driver

- Metric Requirement: Documentation detailing the complete physical, electrical, and messaging requirements for the interface between the MDT wireless data-communications system driver and the on-board wireless data interface shall be provided by the vendor upon delivery.
- Verification Method: Inspect documentation deliverables to ensure compliance.

2.4.12. Data Formatting

2.4.12.1. Data format MDT vehicle wireless data communications system driver

- Metric Requirement: The MDT Vehicle Wireless Data Communications System Driver shall receive data from the MDT Functional Processes in accordance with the EDAPTS Data Formatting Standard. Any MDT Vehicle Wireless Data Communications System Driver internal data formatting and compression methods used shall be documented and provided to the transit property.
- Verification Method: Verify documented data formats in system design documents or specifications.

2.5. APC (Automatic Passenger Counter)

2.5.13. Documentation

2.5.13.1. Interface documentation APC MDT

- Metric Requirement: Documentation detailing the complete physical, electrical, and messaging requirements for the interface between the MDT and the automatic passenger counter shall be provided by the vendor upon delivery.
- Verification Method: Inspect documentation deliverables to ensure compliance.

2.5.14. Functional Performance

2.5.14.1. Command and control APC

- Metric Requirement: The APC shall be able to have collected data retrieved remotely
- Verification Method: Verify in system design document or specifications. Test installation to ensure compliance.

2.5.14.2. Count passengers APC

- Metric Requirement: The APC unit shall count boardings and alightings and provide data to the MDT.
- Verification Method: Verify in system design document or specifications. Test installation to ensure compliance.

2.6. Emergency Actuator

2.6.15. Communications & Electrical Interfacing

2.6.15.1. Interfacing E Actuator

Metric Requirement: For its wired electrical control/data interfaces, the Emergency Actuator shall be able to connect to the MDT, or other on-board peripherals and other equipment.

Signal levels shall be compatible with MDT signal input specifications. Signal structure (protocol, timing, etc.) shall be compatible with MDT signal structure needs.

Verification Method: Verify in vendor's specifications

2.6.16. Documentation

2.6.16.1. Interface documentation emergency actuator MDT

Metric Requirement: Documentation detailing the complete physical, electrical, and messaging requirements for the interface between the MDT and the emergency actuator shall be provided by the vendor upon delivery.

Verification Method: Inspect documentation deliverables to ensure compliance.

2.6.17. Human Factors

2.6.17.1. Accessibility E-Actuator

Metric Requirement: The Emergency Actuator shall be operable from the driver's position, and shall be able to unobtrusively activated in the event of an emergency. The actuator shall be resistant to accidental activation due to normal movement in the driver's compartment.

Verification Method: Test installation to ensure compliance.

2.6.17.2. Inobtrusiveness E-Actuator

Metric Requirement: The Emergency Actuator shall be hidden from passenger view.

Verification Method: Test installation to ensure compliance.

2.6.18. Ruggedness & Reliability

2.6.18.1. Noise resistance E-Actuator

Metric Requirement: The Emergency Actuator's control/data signal interface to the MDT shall be resistant to noise generated in a production bus environment.

Verification Method: Inspect manufacturer certification

2.6.19. System Accuracy

2.6.19.1. Emergency signaling accuracy OBS

Metric Requirement: The emergency actuator shall not allow false signaling of an emergency.

Verification Method: Test deliverables to ensure compliance or inspect supplied certifications

3. Vehicle Wireless Data Communications System

3.1. General Requirements

3.1.1. Installation & Maintenance

3.1.1.1. Removal and replacement OBS Comm

Metric Requirement: On-Board System elements shall be able to be removed and replaced within the specified amount of time.

Units of Measurement: Minutes

Value: 10 minutes

Verification Method: Test installation to ensure compliance.

3.1.1.2. Self diagnostics OBS Comm

Metric Requirement: The On-Board Wireless Communications system shall provide self-test diagnostics to aid in fault isolation.

Verification Method: Verify in system design document or specifications. Test installation to ensure compliance.

3.1.2. Mechanical Interfacing

3.1.2.1. Mounting hole pattern tolerances OBS Comm

Metric Requirement: All On-Board Communications element mounting hole patterns shall be manufactured to within the given tolerance of their specified dimensions.

Units of Measurement: Inches

Value: 0.005

Verification Method: Inspect deliverables to ensure compliance.

3.1.2.2. Mounting hole size tolerances OBS Comm

Metric Requirement: All On-Board Communications element mounting hole dimensions shall be manufactured to within the given tolerance of their specified dimensions.

Units of Measurement: Inches

Value: 0.005

Verification Method: Inspect deliverables to ensure compliance.

3.1.3. Power

3.1.3.1. Over current protection OBS Comm

Metric Requirement: All power connections shall be fused or breakered at the source connection.

Verification Method: Verify in system design document or specifications. Inspect deliverables to ensure compliance.

3.1.3.2. Over current protection RID Comm

Metric Requirement: Any required external power connection shall be fused or breakered at the source connection.
Verification Method: Verify in system design document or specifications. Inspect deliverables to ensure compliance.

3.1.3.3. Backup power OBS Comm emergency management

Metric Requirement: Minimum period of autonomous operation required to support emergency functionality in the event of a power loss.
Units of Measurement: Hours
Value: 1
Verification Method: Test by measuring time delay

3.1.4. Ruggedness & Reliability

3.1.4.1. Emi resistance OBS Comm

Metric Requirement: Shall be resistant to levels of EMI present in a commercial environment.
Verification Method: Inspect manufacturer certification

3.1.4.2. Mtbf OBS Comm

Metric Requirement: Expected mean time between failures.
Units of Measurement: Hours
Value: 15,000
Verification Method: Inspect manufacturer certification

3.1.4.3. Availability OBS Comm

Metric Requirement: Acceptable levels of minimum uptime / maximum downtime in a normal operating environment
Units of Measurement: Percent
Value: 99.9
Verification Method: Inspect manufacturer certification

3.1.5. Safety & Certification

3.1.5.1. Fcc licensing OBS Comm

Metric Requirement: All On-Board Systems Wireless Communications elements shall be provided with necessary FCC licenses for operation in the transit system.
Verification Method: Inspect supplied certifications

3.1.5.2. Ewra compliance OBS Comm

Metric Requirement: All On-Board Systems elements shall be compliant with the California Electronic Waste Recycling Act of 2003.

Verification Method: Inspect supplied certifications

3.2. On-Board Wide-Area Wireless Data Interface

3.2.1. Ruggedness & Reliability

3.2.1.1. Physical shock resistance OBS Comm

Metric Requirement: On-Board Wireless Communications elements shall not be negatively affected by physical shocks and impacts present in a commercial transit environment.

Verification Method: Inspect manufacturer certification

3.2.1.2. Vibration resistance OBS Comm

Metric Requirement: On-Board Wireless Communications elements shall not be negatively affected by the vibrations in a commercial transit environment.

Verification Method: Inspect manufacturer certification

3.2.2. Safety & Certification

3.2.2.1. Dot certification OBS Comm

Metric Requirement: All On-Board Systems Wireless Communications elements shall meet all applicable state and federal DOT standards.

Verification Method: Inspect supplied certifications

3.3. On-board Wide-Area Communications Infrastructure / Repeaters

3.3.3. Communications & Electrical Interfacing

3.3.3.1. Latency OBS Wireless Communications

Metric Requirement: Maximum time for vehicle-update messages sent from the On-Board System to be received by the CSS under typical system load conditions.

Units of Measurement: Seconds

Value: 15 seconds

Verification Method: Test by measuring time delay

3.3.3.2. Reliability OBS Wireless Communications

Metric Requirement: The On-Board Wireless Communications system shall have a specified successful rate (in percentage) in transporting vehicle updates between vehicles and the central site.

Units of Measurement: %
Value: 99.900%
Verification Method: Test by measuring delivery rate

3.3.3.3. Throughput OBS Wireless Communications

Metric Requirement: The On-Board Wireless Communications system shall have a sufficient data-communications throughput rate to ensure that all vehicles in the fleet with the specified update frequency,

Units of Measurement: Vehicle updates per minute

Value: 1

Verification Method: Test by measuring throughput

4. Dynamic Roadside Information Display

4.1. General Requirements

4.1.1. Installation & Maintenance

4.1.1.1. Removal and replacement RID

Metric Requirement: Roadside Information Display elements shall be able to be removed and replaced within the specified amount of time.

Units of Measurement: Minutes

Value: 30 minutes

Verification Method: Test installation to ensure compliance.

4.1.1.2. Self diagnostics RID

Metric Requirement: The Roadside Information Display shall provided self-test diagnostics to aid in fault isolation.

Verification Method: Verify in system design document or specifications. Test installation to ensure compliance.

4.1.2. Mechanical Interfacing

4.1.2.1. Mounting hole pattern tolerances RID

Metric Requirement: All Roadside Information Display element mounting hole patterns shall be manufactured to within the given tolerance of their specified dimensions.

Units of Measurement: Inches

Value: 0.005

Verification Method: Inspect deliverables to ensure compliance.

4.1.2.2. Mounting hole size tolerances RID

Metric Requirement: All Roadside Information Display element mounting hole dimensions shall be manufactured to within the given tolerance of their specified dimensions.

Units of Measurement: Inches

Value: 0.005

Verification Method: Inspect deliverables to ensure compliance.

4.1.3. Ruggedness & Reliability

4.1.3.1. Emi resistance RID

Metric Requirement: Shall be resistant to levels of EMI present in a commercial environment.

Verification Method: Inspect manufacturer certification

4.1.3.2. Mtbf RID

Metric Requirement: Expected mean time between failures.
Units of Measurement: Hours
Value: 7,500
Verification Method: Inspect manufacturer certification

4.1.3.3. Vandalism resistance RID

Metric Requirement: Shall be resistant to displacement or damage by vandalism.
Verification Method: Inspect manufacturer certification

4.1.4. Safety & Certification

4.1.4.1. Fcc licensing RID

Metric Requirement: All Roadside Information Display elements shall be provided with necessary FCC licenses for operation in the transit system.
Verification Method: Inspect supplied certifications

4.1.4.2. Ewra compliance RID

Metric Requirement: All Roadside Information Display elements shall be compliant with the California Electronic Waste Recycling Act of 2003.
Verification Method: Inspect supplied certifications

4.2. Roadside Sign / Display

4.2.1. Computational Hardware

4.2.1.1. Update message responsiveness RID

Metric Requirement: The maximum amount of time the RID shall take to calculate and make available a received update message for display.
Units of Measurement: Seconds
Value: 1
Verification Method: Verify in vendor specifications.

4.2.1.2. Memory capacity RID

Metric Requirement: The Roadside Information Display shall have the necessary memory capacity to handle transit system operational parameter maximums as given in this specification.
Verification Method: Verify in vendor specifications.

4.2.1.3. Storage capacity RID

Metric Requirement: The Roadside Information Display shall have the necessary non-volatile storage capacity to sustain operations with all necessary transit system operation parameter maximums as given in this specification.

Verification Method: Verify in vendor specifications.

4.2.2. Design & Architecture

4.2.2.1. Extensibility RID API

Metric Requirement: Future modifications to the RID API shall be possible and shall not affect existing functionality.

Verification Method: Verify in API documentation.

4.2.3. Functional Performance

4.2.3.1. Command and control RID

Metric Requirement: The RID shall be able to have configuration and system schedule information downloaded to it remotely from the central site.

Verification Method: Verify in system design document or specifications. Test installation to ensure compliance.

4.2.3.2. Banner message size RID

Metric Requirement: The Dynamic Roadside Information Display shall be capable of receiving and then displaying banner messages up to the given character limit.

Units of Measurement: Characters

Value: 40

Verification Method: Verify in system design document or specifications. Test installation to ensure compliance.

4.2.3.3. Banner message quantity RID

Metric Requirement: The Dynamic Roadside Information Display shall be capable of storing and then displaying at least the given number of individual public service banner messages..

Units of Measurement: Messages

Value: 25

Verification Method: Verify in system design document or specifications. Test installation to ensure compliance.

4.2.3.4. Provide ETA RID

Metric Requirement: The Dynamic Roadside Information Display shall have the capability to present minutes until arrival for buses arriving at a stop based on real-time bus trajectory.

Verification Method: Verify in system design document or specifications. Test installation to ensure compliance.

4.2.3.5. Out of service info RID

Metric Requirement: The Dynamic Roadside Information Display shall have the capability to indicate when it is out of service to passengers waiting at a stop.

Verification Method: Verify in system design document or specifications. Test installation to ensure compliance.

4.2.3.6. ADA RID

Metric Requirement: The Dynamic Roadside Information Display shall be capable of supporting the optional dissemination of information to riders with hearing and sight disabilities in accordance with the Americans with Disabilities Act (ADA).

Verification Method: Verify in system design document or specifications. Test installation to ensure compliance.

4.2.4. Human Factors

4.2.4.1. ADA accessibility RID

Metric Requirement: The Roadside Information display shall be conformant to ADA Standards for Accessible Design, 28 CFR Part 36, Chapter 10.

Verification Method: Inspect supplied ADA certification

4.2.5. Power

4.2.5.1. AC supply voltage range RID

Metric Requirement: Voltage range the device must be able to operate within if powered by direct current.

Units of Measurement: VAC

Value: 110 - 125

Verification Method: Verify in vendor's specifications

4.2.5.2. Autonomous power inclement weather RID

Metric Requirement: The Roadside Information Display shall have the specified number of days of solar autonomy if no external power source is part of the system. Any internal batteries shall not be discharged below 50% capacity in order to reach this autonomy.

Units of Measurement: Days

Value: 14

Verification Method: Test by measuring autonomy

4.2.5.3. Autonomous power system recovery RID

Metric Requirement: If no external power source is part of the system, the Roadside Information Display shall recover from a 50% discharge level to a 90% charge level within the specified maximum number of days of normal solar operation.

Units of Measurement: Days

Value: 5

Verification Method: Test by measuring time

4.2.5.4. Over current protection RID

Metric Requirement: All power connections shall be fused or breakered at the source connection.

Verification Method: Verify in vendor's specifications

4.2.6. Safety & Certification

4.2.6.1. UI certification RID

Metric Requirement: The Roadside Information Display shall be listed with Underwriters Laboratories if externally AC powered.

Verification Method: Inspect supplied certifications

4.2.7. System Accuracy

4.2.7.1. Time reporting accuracy Sign

Metric Requirement: Estimated minutes until arrival shall be accurate to within the specified number of seconds.

Units of Measurement: Seconds

Value: 60

Verification Method: Test deliverables to ensure compliance or inspect supplied certifications

4.2.7.2. Time synchronization RID

Metric Requirement: If any time measurement is utilized, it shall be synchronized with Coordinated Universal Time (UTC), and maintain accuracy within the specified limit.

Units of Measurement: Seconds

Value: 1

Verification Method: Inspect supplied certifications

4.3. Roadside Post

4.3.8. Safety & Certification

4.3.8.1. Rigidity RID Mounting

Metric Requirement: Roadside Information Display post shall meet applicable state and federal DOT standards for crash safety.

Verification Method: Perform design analysis or inspect supplied certifications.

4.4. Roadside Post Foundation

4.4.9. Safety & Certification

4.4.9.1. Wind resistance RID Mounting

Metric Requirement: Roadside Information Display foundations and posts shall comply with the Uniform Building Code with regard to wind resistance.

Verification Method: Perform design analysis or inspect supplied certifications.

4.4.9.2. Earthquake resistance RID Mounting

Metric Requirement: Roadside Information Display foundations and posts shall be earthquake resistant when installed in earthquake-prone areas.

Verification Method: Perform design analysis or inspect supplied certifications.

4.5. RID Functional Processes

4.5.10. Data Formatting

4.5.10.1. Data format RID functional processes

Metric Requirement: The RID functional processes shall transfer data to the RID Data Communications System Driver in accordance with the EDAPTS Data Formatting Standard.

Verification Method: Verify documented data formats in system design documents or specifications.

4.5.10.2. Data format RID functional processes

Metric Requirement: The RID functional processes shall transfer data to and from the RID Communications System Driver in accordance with the EDAPTS Data Formatting Standard.

Verification Method: Verify documented data formats in system design documents or specifications.

4.6. RID Communications System Driver

4.6.11. Data Formatting

4.6.11.1. Data format RID vehicle wireless data communications system driver

Metric Requirement: The RID Communications System Driver shall receive data from the RID Functional Processes in accordance with the EDAPTS Data Formatting Standard. Any RID Communications System Driver internal data formatting and compression methods used shall be documented and provided to the transit property.

Verification Method: Verify documented data formats in system design documents or specifications.

4.6.11.2. Data format RID data communications system driver

- Metric Requirement:** The RID Data Communications System Driver shall receive data from the RID Functional Processes in accordance with the EDAPTS Data Formatting Standard. Any RID Data Communications System Driver internal data formatting and compression methods used shall be documented and provided to the transit property.
- Verification Method:** Verify documented data formats in system design documents or specifications.

5. Roadside Data Communications System

5.1. General Requirements

5.1.1. Installation & Maintenance

5.1.1.1. Removal and replacement RID Comm

Metric Requirement: Roadside Information Display elements shall be able to be removed and replaced within the specified amount of time.

Units of Measurement: Minutes

Value: 30 minutes

Verification Method: Test installation to ensure compliance.

5.1.2. Mechanical Interfacing

5.1.2.1. Mounting hole pattern tolerances RID Comm

Metric Requirement: All Roadside Communications element mounting hole patterns shall be manufactured to within the given tolerance of their specified dimensions.

Units of Measurement: Inches

Value: 0.005

Verification Method: Inspect deliverables to ensure compliance.

5.1.2.2. Mounting hole size tolerances RID Comm

Metric Requirement: All Roadside Communications element mounting hole dimensions shall be manufactured to within the given tolerance of their specified dimensions.

Units of Measurement: Inches

Value: 0.005

Verification Method: Inspect deliverables to ensure compliance.

5.1.3. Ruggedness & Reliability

5.1.3.1. Emi resistance RID Comm

Metric Requirement: Shall be resistant to levels of EMI present in a commercial environment.

Verification Method: Inspect manufacturer certification

5.1.3.2. Mtbf RID Comm

Metric Requirement: Expected mean time between failures.

Units of Measurement: Hours

Value: 15,000

Verification Method: Inspect manufacturer certification

5.1.3.3. Availability RID Comm

Metric Requirement: Acceptable levels of minimum uptime / maximum downtime in a normal operating environment
Units of Measurement: Percent
Value: 99.9
Verification Method: Inspect manufacturer certification

5.1.4. Safety & Certification

5.1.4.1. Fcc licensing RID Comm

Metric Requirement: All Roadside Information Display elements shall be provided with necessary FCC licenses for operation in the transit system.
Verification Method: Inspect supplied certifications

5.1.4.2. Ewra compliance RID Comm

Metric Requirement: All Roadside Information Display elements shall be compliant with the California Electronic Waste Recycling Act of 2003.
Verification Method: Inspect supplied certifications

5.2. Roadside Communications Infrastructure / Repeaters

5.2.1. Communications & Electrical Interfacing

5.2.1.1. Latency RID Communications

Metric Requirement: Maximum time for vehicle-update messages sent from the CSS to be received by the RID under typical system load conditions.
Units of Measurement: Seconds
Value: 15 seconds
Verification Method: Test by measuring time delay

5.2.1.2. Reliability RID Communications

Metric Requirement: The Roadside Information Display (RID) communications system shall meet or exceed the specified successful delivery rate (in percentage) for all vehicle updates transported between vehicles and the central site.
Units of Measurement: %
Value: 99.900%
Verification Method: Test by measuring delivery rate

5.2.1.3. Throughput RID Communications

Metric Requirement: The Roadside Information Display Communications system shall have a sufficient throughput rate to ensure that all vehicles in the fleet with the specified update frequency.

Units of Measurement: RID updates per minute

Value: 2

Verification Method: Test by measuring throughput

6. Advanced Transit Management System

6.1. General Requirements

6.1.1. Computational Hardware

6.1.1.1. User input responsiveness ATRMS

Metric Requirement: The maximum amount of time the ATRMS shall take to respond to operator input for vehicle tracking operations.

Units of Measurement: Seconds

Value: 1

Verification Method: Test by timing user operations.

6.1.1.2. Memory capacity ATRMS

Metric Requirement: The ATRMS shall have the necessary memory capacity to handle transit system operational parameter maximums as given in this specification.

Verification Method: Verify in vendor specifications.

6.1.2. Functional Performance

6.1.2.1. ATRMS client quantity CSS

Metric Requirement: The central software shall be capable of supporting at least the given number of simultaneously running ATRMS clients.

Units of Measurement: Clients

Value: 5

Verification Method: Verify system design document or specifications.

6.1.2.2. Emergency handling quantity CSS

Metric Requirement: The central software shall be capable of supporting at least the given number of simultaneous emergency conditions.

Units of Measurement: Emergencies

Value: 5

Verification Method: Verify in system design document or specifications. Test installation to ensure compliance.

6.1.3. Human Factors

6.1.3.1. GUI readability ATRMS

Metric Requirement: The ATRMS GUI shall be readable by employees of varying visual capabilities.

Verification Method: Test installation to ensure compliance.

6.1.3.2. Font scalability ATRMS

Metric Requirement: ATRMS display fonts shall be scalable from small to large.
Verification Method: Verify in system design document or specifications. Test installation to ensure compliance.

6.1.4. Power

6.1.4.1. Backup power ATRMS emergency management

Metric Requirement: Minimum period of autonomous operation required to support emergency functionality in the event of a power loss.

Units of Measurement: Hours

Value: 1

Verification Method: Test by measuring time

6.1.5. System Accuracy

6.1.5.1. Time synchronization ATRMS

Metric Requirement: If any time measurement is utilized, it shall be synchronized with Coordinated Universal Time (UTC), and maintain accuracy within the specified limit.

Units of Measurement: Seconds

Value: 1

Verification Method: Inspect supplied certifications

6.2. On-Board Equipment Administration Controls

6.2.1. Functional Performance

6.2.1.1. OBS administration ATRMS

Metric Requirement: The ATRMS consoles shall have the capability to allow the user to remotely administer the On-Board Systems aboard each vehicle.

Verification Method: Verify in system design document or specifications. Test installation to ensure compliance.

6.2.2. Data Formatting

6.2.2.1. Data format on board equipment administration controls

Metric Requirement: The On-Board Equipment Administration Controls shall transfer data to and from the ATRMS API in accordance with the EDAPTS Data Formatting Standard.

Verification Method: Verify documented data formats in system design documents or specifications.

6.3. Schedule Management & Administration Tools & Controls

6.3.3. Functional Performance

6.3.3.1. Schedule builder ATRMS

Metric Requirement: The ATRMS consoles shall have the capability to allow the user to build a schedule, disseminate it to the fleet, and track the schedule version on each vehicle in the fleet.

Verification Method: Verify in system design document or specifications. Test installation to ensure compliance.

6.3.4. Data Formatting

6.3.4.1. Data format schedule management & administration tools & controls

Metric Requirement: The Schedule Management & Administration Tools & Controls shall transfer data to and from the ATRMS API in accordance with the EDAPTS Data Formatting Standard.

Verification Method: Verify documented data formats in system design documents or specifications.

6.4. Driver Management Controls

6.4.5. Data Formatting

6.4.5.1. Data format driver management controls

Metric Requirement: The Driver Management Controls shall transfer data to and from the ATRMS API in accordance with the EDAPTS Data Formatting Standard.

Verification Method: Verify documented data formats in system design documents or specifications.

6.5. Emergency Management Display

6.5.6. Functional Performance

6.5.6.1. Emergency alarm handling ATRMS

Metric Requirement: The ATRMS consoles shall have the capability to receive vehicle emergency alarms, track vehicles with alarms, and log actions taken.

Verification Method: Verify in system design document or specifications. Test installation to ensure compliance.

6.5.6.2. Emergency planning ATRMS

Metric Requirement: The ATMS consoles shall have the capability to guide users through the process of creating an emergency plan for handling driver's emergency alarms. This plan shall include procedures for interacting with local law enforcement and forms for developing an emergency callout list.

Verification Method: Verify in system design document or specifications. Test installation to ensure compliance.

6.5.7. Human Factors

6.5.7.1. Audibility emergency ATRMS

Metric Requirement: The ATRMS shall sound an audio alarm of at least the specified volume at 1 meter.

Units of Measurement: DB

Value: 85

Verification Method: Verify in system design document or specifications. Test installation to ensure compliance.

6.5.7.2. Visibility emergency ATRMS

Metric Requirement: The ATRMS shall have a visual emergency indicator that flashes and attracts the attention of any employee within the room the ATRMS is installed in.

Verification Method: Verify in system design document or specifications. Test installation to ensure compliance.

6.5.8. Data Formatting

6.5.8.1. Data format emergency management display

Metric Requirement: The Emergency Management Display shall transfer data to and from the ATRMS API in accordance with the EDAPTS Data Formatting Standard.

Verification Method: Verify documented data formats in system design documents or specifications.

6.6. Roadside Information Display Controls

6.6.9. Functional Performance

6.6.9.1. RID administration ATRMS

Metric Requirement: The ATRMS consoles shall have the capability to allow the user to administer each Dynamic Roadside Information Display in the system, including downloading schedules and executables, operational status, and tracking file versions on each sign.

Verification Method: Verify in system design document or specifications. Test installation to ensure compliance.

6.6.10. Data Formatting

6.6.10.1. Data format roadside information display controls

Metric Requirement: The Roadside Information Display Controls shall transfer data to and from the ATRMS API in accordance with the EDAPTS Data Formatting Standard.

Verification Method: Verify documented data formats in system design documents or specifications.

6.7. Vehicle Tracking Display

6.7.11. Functional Performance

6.7.11.1. Track transit fleet ATRMS

Metric Requirement: The ATRMS consoles shall have the capability to track transit vehicles via map-based and tabular display.

Verification Method: Verify in system design document or specifications. Inspect deliverables to ensure compliance.

6.7.12. Data Formatting

6.7.12.1. Data format vehicle tracking display

Metric Requirement: The Vehicle Tracking Display shall transfer data to and from the ATRMS API in accordance with the EDAPTS Data Formatting Standard.

Verification Method: Verify documented data formats in system design documents or specifications.

6.8. Schedule Adherence Display

6.8.13. Functional Performance

6.8.13.1. Schedule adherence display ATRMS

Metric Requirement: The ATRMS consoles shall have the capability to track transit vehicle schedule information and display it to the user.

Verification Method: Verify in system design document or specifications. Test installation to ensure compliance.

6.8.14. Data Formatting

6.8.14.1. Data format schedule adherence display

Metric Requirement: The Schedule Adherence Display shall transfer data to and from the ATRMS API in accordance with the EDAPTS Data Formatting Standard.

Verification Method: Verify documented data formats in system design documents or specifications.

6.8.15. System Accuracy

6.8.15.1. Time reporting accuracy ATRMS display

Metric Requirement: Time estimates shall be accurate within the specified number of seconds.

Units of Measurement: Seconds

Value: 30

Verification Method: Test deliverables to ensure compliance or inspect supplied certifications

6.9. Passenger Boardings Display

6.9.16. Functional Performance

6.9.16.1. Vehicle loading info ATRMS

- Metric Requirement: The ATRMS consoles shall have the capability to track transit vehicle loading information and display it to the user.
- Verification Method: Verify in system design document or specifications. Inspect deliverables to ensure compliance.

6.9.17. Data Formatting

6.9.17.1. Data format passenger boardings display

- Metric Requirement: The Passenger Boardings Display shall transfer data to and from the ATRMS API in accordance with the EDAPTS Data Formatting Standard.
- Verification Method: Verify documented data formats in system design documents or specifications.

6.10. Ridership Statistics Reporting Controls

6.10.18. Functional Performance

6.10.18. Ridership reports ATRMS

1.

- Metric Requirement: The ATRMS consoles shall have the capability to compile and present ridership reports for the user.
- Verification Method: Verify in system design document or specifications. Inspect deliverables to ensure compliance.

6.10.19. Data Formatting

6.10.19. Data format ridership statistics reporting

1.

- Metric Requirement: The Ridership Statistics Reporting Controls shall transfer data to and from the ATRMS API in accordance with the EDAPTS Data Formatting Standard.
- Verification Method: Verify documented data formats in system design documents or specifications.

6.11. Schedule Adherence Statistics Reporting Controls

6.11.20. Functional Performance

6.11.20. Schedule adherence reports ATRMS

1.

- Metric Requirement: The ATRMS consoles shall have the capability to compile and present schedule adherence reports for the user.

Verification Method: Verify in system design document or specifications. Inspect deliverables to ensure compliance.

6.11.21. Data Formatting

6.11.21. Data format schedule adherence statistics reporting

1.

Metric Requirement: The Schedule Adherence Statistics Reporting Controls shall transfer data to and from the ATRMS API in accordance with the EDAPTS Data Formatting Standard.

Verification Method: Verify documented data formats in system design documents or specifications.

6.11.22. System Accuracy

6.11.22. Time reporting accuracy ATRMS statistics

1.

Metric Requirement: Time estimates shall be accurate within the specified number of seconds.

Units of Measurement: Seconds

Value: 30

Verification Method: Test deliverables to ensure compliance or inspect supplied certifications

6.12. System User Management Controls

6.12.23. Functional Performance

6.12.23. ATRMS user admin ATRMS

1.

Metric Requirement: The ATRMS consoles shall have the capability to allow the user to administer all system users and their permissions.

Verification Method: Verify in system design document or specifications. Test installation to ensure compliance.

6.12.24. Data Formatting

6.12.24. Data format system user management controls

1.

Metric Requirement: The System User Management Controls shall transfer data to and from the ATRMS API in accordance with the EDAPTS Data Formatting Standard.

Verification Method: Verify documented data formats in system design documents or specifications.

7. ATRMS Communications

7.1. General Requirements

7.1.1. Power

7.1.1.1. Backup power ATRMS Comm emergency management

Metric Requirement: Minimum period of autonomous operation required to support emergency functionality in the event of a power loss.

Units of Measurement: Hours

Value: 1

Verification Method: Test by measuring time

7.1.2. Ruggedness & Reliability

7.1.2.1. Mtbf ATRMS Comm

Metric Requirement: Expected mean time between failures.

Units of Measurement: Hours

Value: 15,000

Verification Method: Inspect manufacturer certification

7.1.2.2. Availability ATRMS Comm

Metric Requirement: Acceptable levels of minimum uptime / maximum downtime in a normal operating environment

Units of Measurement: Percent

Value: 99.9

Verification Method: Inspect manufacturer certification

7.2. ATRMS / Central-Site Data Interfaces

7.2.1. Functional Performance

7.2.1.1. Network connectivity central site

Metric Requirement: If utilizing TCP/IP communication, ATRMS clients shall function from within a Network Address Translation (NAT) network.

Verification Method: Verify in system design document or specifications. Test installation to ensure compliance.

7.3. ATRMS Communications Infrastructure / Repeaters

7.3.2. Communications & Electrical Interfacing

7.3.2.1. Reliability ATRMS Comm

Metric Requirement: The ATRMS Communications System shall meet or exceed the specified successful delivery percentage rate for all data transported between the ATRMS and the ATRMS API.
Units of Measurement: %
Value: 99.99%
Verification Method: Test by measuring delivery rate

7.3.2.2. Latency ATRMS Comm

Metric Requirement: Maximum time for a message and response between the ATRMS and the CSS.
Units of Measurement: Seconds
Value: 5
Verification Method: Test by measuring time delay

8. Central Site Software

8.1. General Requirements

8.1.1. Computational Hardware

8.1.1.1. Responsiveness CSS

Metric Requirement: The maximum amount of time the Central Site Software shall take to respond to user or system-driven input for vehicle tracking operations

Units of Measurement: Seconds

Value: 1

Verification Method: Time system operations.

8.1.1.2. Memory capacity CSS

Metric Requirement: The Central Site Software shall have the necessary memory capacity to handle transit system operational parameter maximums as given in this specification, and the required number of field elements as specified by the transit provider.

Verification Method: Verify in vendor specifications.

8.1.1.3. Storage capacity CSS

Metric Requirement: The Central Site Software shall have the necessary non-volatile storage capacity to sustain operations with all necessary transit system operation parameter maximums as given in this specification.

Verification Method: Verify in vendor specifications.

8.1.2. Functional Performance

8.1.2.1. Provide data store CSS

Metric Requirement: The central site software shall have a data store for all system configuration, schedule, and collected data.

Verification Method: Verify in system design document or specifications. Inspect deliverables to ensure compliance.

8.1.3. Installation & Maintenance

8.1.3.1. Self diagnostics RID Comm

Metric Requirement: The Roadside Information Display Communications system shall provided self-test diagnostics to aid in fault isolation.

Verification Method: Verify in system design document or specifications. Test installation to ensure compliance.

8.1.3.2. Self diagnostics RID Comm

Metric Requirement: The Central Site Software shall provide self-test diagnostics to aid in fault isolation.
Verification Method: Verify in system design document or specifications. Test installation to ensure compliance.

8.1.4. Power

8.1.4.1. Backup power CSS emergency management

Metric Requirement: Minimum period of autonomous operation required to support emergency functionality in the event of a power loss.
Units of Measurement: Hours
Value: 1
Verification Method: Test by measuring time

8.1.5. Ruggedness & Reliability

8.1.5.1. Availability CSS

Metric Requirement: Acceptable levels of minimum uptime / maximum downtime in a normal operating environment
Units of Measurement: Percent
Value: 99.99
Verification Method: Inspect manufacturer certification

8.1.6. System Accuracy

8.1.6.1. Time synchronization CSS

Metric Requirement: If any time measurement is utilized, it shall be synchronized with Coordinated Universal Time (UTC), and maintain accuracy within the specified limit.
Units of Measurement: Seconds
Value: 1
Verification Method: Inspect supplied certifications

8.2. On-Board Systems API

8.2.1. Functional Performance

8.2.1.1. MDT wireless data interface CSS

Metric Requirement: The central site software shall have an interface to the on-board systems wireless data communications system.
Verification Method: Verify in system design document or specifications. Inspect deliverables to ensure compliance.

8.2.2. Data Formatting

8.2.2.1. Data format OBS API

Metric Requirement: The CSS On-Board Systems API shall transfer from the CSS Vehicle Wireless Data Communications Driver in accordance with the EDAPTS Data Formatting Standard.

Verification Method: Verify documented data formats in system design documents or specifications.

8.3. ATRMS API

8.3.3. Design & Architecture

8.3.3.1. Extensibility ATRMS API

Metric Requirement: Future modifications to the ATRMS API shall be possible shall not affect existing functionality.

Verification Method: Verify in API documentation.

8.3.4. Functional Performance

8.3.4.1. ATRMS API CSS

Metric Requirement: The central site software shall have the capability to provide system data to other system functions via electronic computer calls over a network.

Verification Method: Verify in system design document or specifications. Test installation to ensure compliance.

8.3.5. Data Formatting

8.3.5.1. Data format ATRMS API

Metric Requirement: The ATRMS API shall transfer data to and from all ATRMS displays in accordance with the EDAPTS Data Formatting Standard.

Verification Method: Verify documented data formats in system design documents or specifications.

8.4. Data Store

8.4.6. Design & Architecture

8.4.6.1. Open data storage facility

Metric Requirement: Direct, unfiltered, read-only access shall be provided to the data store.

Verification Method: Verify in vendor documentation and specifications.

8.4.7. Documentation

8.4.7.1. Open data storage documentation

Metric Requirement: The open data-storage-facility documentation shall be comprehensive and cover all aspects of the data-store including providing a complete data-dictionary, table definitions and relationships as necessary, and all data structure information necessary to query the data-store from an external interface.

Verification Method: Verify document comprehensiveness.

8.4.8. Functional Performance

8.4.8.1. Capacity datastore

Metric Requirement: The capacity required to store all entered and recorded data for a minimum period of time before expungment or other such maintenance is required.

Units of Measurement: Months

Value: 60

Verification Method: Verify in system design document or specifications.

8.4.8.2. Backup interval datastore

Metric Requirement: The minimum allowable intervals between backups of the data store.

Units of Measurement: Days

Value: 7

Verification Method: Verify in system design document or specifications.

8.4.8.3. Export capability datastore

Metric Requirement: The data storage facility shall have the capability to export data in whole or in part for given ranges, to be used for other functions.

Verification Method: Verify in system design document or specifications. Test installation to ensure compliance.

8.4.8.4. Expunge capability datastore

Metric Requirement: The data storage facility shall have the capability to expunge all entered or recorded data for a given date range.

Verification Method: Verify in system design document or specifications. Test installation to ensure compliance.

8.4.8.5. Backup capability datastore

Metric Requirement: The data storage facility shall have the capability to back up or archive all entered and recorded data in whole or in part (given data range). Mechanisms shall be available for both user-initiated and scheduled automatic backups.

Verification Method: Verify in system design document or specifications. Test installation to ensure compliance.

8.4.9. Ruggedness & Reliability

8.4.9.1. Operational lifecycle data backup

Metric Requirement: Maximum time between backups of data-storage facility

Units of Measurement: Days

Value: 30

Verification Method: Inspect manufacturer certification

8.5. CSS Vehicle Wireless Data Communications Systems Driver

8.5.10. Documentation

8.5.10.1. Interface documentation CSS comm driver

Metric Requirement: Documentation detailing the complete physical, electrical, and messaging requirements for the interface between the CSS vehicle communications system driver and the central-site wireless data interface shall be provided by the vendor upon delivery.

Verification Method: Inspect documentation deliverables to ensure compliance.

8.5.11. Data Formatting

8.5.11.1. Data format CSS vehicle wireless data communications system driver

Metric Requirement: The CSS Vehicle Wireless Data Communications System Driver shall transfer data to the CSS On-Board Systems API in accordance with the EDAPTS Data Formatting Standard. Any CSS Vehicle Wireless Data Communications System Driver internal data formatting and compression methods used over the communications link shall be documented and provided to the transit property.

Verification Method: Verify documented data formats in system design documents or specifications.

8.6. Roadside Information Display API

8.6.12. Functional Performance

8.6.12.1. RID data interface CSS

Metric Requirement: The central site software shall have an interface to the Dynamic Roadside Information Display data communications system.

Verification Method: Verify in system design document or specifications. Inspect deliverables to ensure compliance.

8.6.13. Data Formatting

8.6.13.1. Data format CSS RID API

- Metric Requirement: The CSS RID API shall receive data from the CSS RID Data Communications System Driver in accordance with the EDAPTS Data Formatting Standard.
- Verification Method: Verify documented data formats in system design documents or specifications.

8.7. CSS RID Data Communications System Driver

8.7.14. Data Formatting

8.7.14.1. Data format CSS roadside communications system driver

- Metric Requirement: The CSS RID Communications System Driver shall transfer data to the CSS Roadside Display API in accordance with the EDAPTS Data Formatting Standard. Any CSS RID Communications System Driver internal data formatting and compression methods used over the communications link shall be documented and provided to the transit property.
- Verification Method: Verify documented data formats in system design documents or specifications.

8.8. Traveler Information API

8.8.15. Design & Architecture

8.8.15.1. Extensibility Traveler Information API

- Metric Requirement: Future modifications to the Traveler Information API shall be possible shall not affect existing functionality.
- Verification Method: Verify in API documentation.

8.8.16. Functional Performance

8.8.16.1. Traveler Information API CSS

- Metric Requirement: The central site software shall have the capability to provide system data to outside system functions via electronic computer calls over a network.
- Verification Method: Verify in system design document or specifications. Test installation to ensure compliance.

8.8.17. Data Formatting

8.8.17.1. Data format traveler information API

- Metric Requirement: The Traveler Information API shall transfer data to and from all external traveler information using entities in accordance with the EDAPTS Data Formatting Standard.
- Verification Method: Verify documented data formats in system design documents or specifications.

8.8.18. System Accuracy

8.8.18.1. Time reporting accuracy Traveler API

Metric Requirement: Time estimates shall be accurate within the specified number of seconds.

Units of Measurement: Seconds

Value: 30

Verification Method: Test deliverables to ensure compliance or inspect supplied certifications

9. System Input Data

9.1. General Requirements

9.2. Stop-Point List

9.2.1. Data Formatting

9.2.1.1. Data format stop point list

Metric Requirement: The Stop-Point List shall be formatted in accordance with the EDAPTS Data Formatting Standard.

Verification Method: Verify documented data formats in system design documents or specifications.

9.2.2. System Accuracy

9.2.2.1. Georeference stop-point accuracy

Metric Requirement: Latitude and longitude estimates shall be accurate to within the specified number of minutes.

Units of Measurement: Meters

Value: 10

Verification Method: Inspect supplied certifications

9.3. Timetable

9.3.3. Data Formatting

9.3.3.1. Data format timetable

Metric Requirement: The Timetable shall be formatted in accordance with the EDAPTS Data Formatting Standard.

Verification Method: Verify documented data formats in system design documents or specifications.

9.4. Work / Runs List

9.4.4. Data Formatting

9.4.4.1. Data format work runs list

Metric Requirement: The Work/Runs List shall be formatted in accordance with the EDAPTS Data Formatting Standard.

Verification Method: Verify documented data formats in system design documents or specifications.



EDAPTS

Smart Transit System



RFP 07-014
Exhibit B

Cal Poly Pomona EDAPTS Test Deployment

EDAPTS Data Formatting Standards

Prepared for
California Partners for Advanced Transit and Highways
California Department of Transportation

Prepared by
Xudong Jia, Ph.D., P.E
California State Polytechnic University, Pomona

And

Jeff Gerfen
California Polytechnic State University, San Luis Obispo

Under PATH Contract TO 6403

June 8, 2007

TABLE OF CONTENTS

1.	Introduction and Overview	1
2.	Specified Interface Object Transfers.....	2
2.1	OnBoard Systems to/from Central Site Software.....	3
2.1.1	Display current stop schedule adherence to driver (F-104).....	3
2.1.2	Display time-until-departure at current stop (F-105).....	3
2.1.3	Accept, validate, and log pass media during boarding (F-106).....	3
2.1.4	Collect and Record boardings and alightings (F-107).....	4
2.1.5	Receive, Store, & Transfer Bus Stop Data (F-108)	4
2.1.6	Collect vehicle odometer data (F-111).....	4
2.1.7	Provide notification of stop arrivals and departures (F-112).....	5
2.1.8	Collect driver id during login (F-113)	5
2.1.9	Collect route number during login (F-114).....	5
2.1.10	Provide Real-Time Vehicle Updates (F-116).....	6
2.1.11	Declare on-board emergency (F-118).....	6
2.1.12	Manually collect and record passenger boarding (F-120)	6
2.2	Central Site Software (CSS) to/from Roadside Information Display (RID).....	7
2.2.1	Provide Estimated Time Until Arrival at Stops (F-201)	7
2.2.2	Provide Dynamic Public Service Information at Stops (F-202)	7
2.3	Central Site Software (CSS) to External Traveler Information Services	8
2.3.1	Provide API for Transit Traveler Information (F-301)	8
2.4	ATRMS to/from Central Site Software (CSS).....	9
2.4.1	Provide geolocation tracking display (F-401)	9
2.4.2	Display schedule adherence information (F-402).....	9
2.4.3	Display Passenger Boarding / Alighting Information (F-403)	10
2.4.4	Handle driver emergency button dispatch & management (F-404)	10
2.4.5	Provide statistical ridership reports for dispatch & management (F-405).....	11
2.4.6	Provide statistical schedule adherence reports (F-406)	11
2.4.7	Provide controls for dissemination of bus pass lists (F-407).....	12
2.4.8	Provide controls for roadside banner message display (F-411).....	12
2.4.9	Provide statistical boarding and alighting reports (F-413)	13

3.	Interface-Specific Data Objects	14
3.1	FcElectronicTransaction	14
3.2	FcMediaList	14
3.3	ImEvent	15
3.4	MDTActivityList	17
3.5	MDTLogRequest	17
3.6	ObStopPointRecord	18
3.7	ObUpdate	18
3.8	PiSchedAdherenceOffSched	19
3.9	RealTimeVehiclePosition	20
3.10	RoadsideBannerMsg	20
3.11	SchMasterSchedulePackage	21
3.12	SchTimeTableVersion	21
3.13	SignUpdate	22
3.14	TravInfoObStopPointRecord	22
4.	Common Data Objects	24
4.1	CptPTVehicleParameter	24
4.2	CptStopPoint	24
4.3	CPT_ActivationDate	25
4.4	CPT_AgencyID	25
4.5	CPT_DeactivationDate	25
4.6	CPT_OperatorID	26
4.7	CPT_PTVehicleID	26
4.8	CPT_SeverityLevel	26
4.9	FcBoardingTransaction	27
4.10	FcElectronicTransaction	27
4.11	FC_AccountID	28
4.12	FC_InstitutionID	28
4.13	FC_ListType	28
4.14	FC_MonetaryInstrumentType	29
4.15	FC_RiderClassification	29
4.16	FC_TransactionResult	30

4.17	IM_AcknowledgeType	30
4.18	IM_Active.....	31
4.19	IM_EventDateTime	31
4.20	IM_EventLocation.....	31
4.21	IM_IncidentDescription.....	32
4.22	IM_IncidentType	32
4.23	IM_SourceID.....	32
4.24	IM_SourceType	32
4.25	MDTStopPointRecord.....	33
4.26	MDT_ActivityTime.....	33
4.27	MDT_ActivityType	34
4.28	MDT_Bin.....	34
4.29	MDT_Loader	34
4.30	MDT_Process	35
4.31	MDT_Route.....	35
4.32	MDT_Settings	35
4.33	MDT_Version	36
4.34	MDT_Wrapper.....	36
4.35	ObDoorRecord.....	36
4.36	OB_PassengerBoarding.....	37
4.37	OB_PassengerAlighting	37
4.38	OB_StopPointZoneEntry.....	37
4.39	OB_StopPointZoneExit.....	38
4.40	PI_DepartTimeScheduled.....	38
4.41	PI_OffSchedule.....	38
4.42	RID_BannerMsg.....	39
4.43	SchHoliday	39
4.44	SchMasterSchedule	39
4.45	SchRoute.....	40
4.46	SchTrip	40
4.47	SchTripTimePtHdr.....	41
4.48	SCH_DayType.....	42
4.49	SCH_HolidayDate.....	42

4.50	SCH_HolidayDescription.....	43
4.51	SCH_RouteDesignator.....	43
4.52	SCH_RouteID.....	43
4.53	SCH_RouteName.....	43
4.54	SCH_StopPointSequenceNo.....	44
4.55	SCH_TimeBegin.....	44
4.56	SCH_TimeEnd.....	44
4.57	SCH_TimePointID.....	45
4.58	SCH_TimePointName.....	45
4.59	SCH_TimeTableVersionID.....	45
4.60	SCH_TimeTableVersionName.....	45
4.61	SCH_TripID.....	46
4.62	SCH_TripTimePtAttribute.....	46
4.63	SCH_TripTimePtTime.....	47
4.64	SCH_TripTimePtWait.....	47
4.65	SpGeoPoint.....	48
4.66	SP_AngularDirection.....	48
4.67	SP_Datum.....	49
4.68	SP_Latitude.....	49
4.69	SP_Longitude.....	50

1. INTRODUCTION AND OVERVIEW

The EDAPTS Data-Formatting Standard consists of the following three sections:

- Specified Interface Object Transfers
- Interface-Specific Data Objects
- Common Data Objects

Section 2, Specified Interface Object Transfers, defines all data objects which may be made between EDAPTS Components. These data object transfers are based on EDAPTS system functions, which are things that the system does a user or an entity. Note that these transfers are not specifying inter-element movement of data, but rather inter-component data movement.

Section 3, Interface-Specific Data Objects, defines the content of each EDAPTS Interface Object Transfer specified in section 2.

Section 4, Common Data Objects provides the low-level details of each Interface Specific Data Object defined in section 3.

The EDAPTS Data-Formatting Standard document is in compliance with Extensible Markup Language XML 1.1.

2. SPECIFIED INTERFACE OBJECT TRANSFERS

Interface object transfers are specified for these four general categories of EDAPTS inter-Component transfers:

- OnBoard Systems to/from Central Site Software
- Central Site Software to/from Roadside Information Display
- Central Site Software to External Traveler Information Service
- ATRMS to/from Central Site Software

Each data transfer specified is directly traceable to EDAPTS system functions as selectable in the EDAPTS Performance Specification Generator software. Note that the data transfers are merely specified by name in this section with no low-level details provided.

The tables contained within this section are used by first looking up the EDAPTS system function, then looking within the table following to determine the name of the EDAPTS data object, the names of the EDAPTS elements the data is transferred between, and any assumptions made. For example, section 2.1.1 (titled “Display current stop schedule adherence to driver (F-104)”) refers to the system function that lets the driver of the transit vehicle know what their schedule adherence is when they arrive at a stop. This system function can be found under F-104 in the EDAPTS System Functions worksheet of the EDAPTS Performance Specification Tables. Looking at the table following the section 2.1.1 heading, the name of the EDAPTS data object is listed that is used to implement this function – PiSchedAdherenceOffSched. This data object can then be looked up in section 3 below to learn more about its contents. The next two columns in the table are titled “origin element” and “destination element”. These indicate the EDAPTS Element where the data object originates from and terminates at. For this example, the PiSchedAdherenceOffSched data object originates at element E-701, On-board Systems API and terminates at element E-107, MDT Functional Processes. Although EDAPTS Element names are noted in this table, it is important to note that these are merely the elements within the EDAPTS components that the data transfer is between. Lastly, each data object transfer table within this section lists any assumptions made for the defined transfer.

2.1 OnBoard Systems to/from Central Site Software

2.1.1 DISPLAY CURRENT STOP SCHEDULE ADHERENCE TO DRIVER (F-104)

EDAPTS DATA OBJECT	ORIGIN ELEMENT	DESTINATION ELEMENT
<PiSchedAdherenceOffSched>	E-701	E-107
	On-Board Systems API	MDT Functional Processes
ASSUMPTIONS: This function requires that <SchMasterSchedulePackage> is available to element E-107, MDT Functional Processes.		

2.1.2 DISPLAY TIME-UNTIL-DEPARTURE AT CURRENT STOP (F-105)

EDAPTS DATA OBJECT	ORIGIN ELEMENT	DESTINATION ELEMENT
<PiSchedAdherenceOffSched>	E-701	E-107
	On-Board Systems API	MDT Functional Processes
ASSUMPTIONS: This function requires that <SchMasterSchedulePackage> is available to element E-107, MDT Functional Processes.		

2.1.3 ACCEPT, VALIDATE, AND LOG PASS MEDIA DURING BOARDING (F-106)

EDAPTS DATA OBJECT	ORIGIN ELEMENT	DESTINATION ELEMENT
<FcMediaList>	E-102	E-107
	Pass/Fare Media Reader	MDT Functional Processes
ASSUMPTIONS: None.		

2.1.4 COLLECT AND RECORD BOARDINGS AND ALIGHTINGS (F-107)

EDAPTS DATA OBJECT	ORIGIN ELEMENT	DESTINATION ELEMENT
<ObStopPointRecord>	E-106 Automatic Passenger Counter	E-107 MDT Functional Processes
ASSUMPTIONS: This function requires that <SchMasterSchedulePackage> is available to element E-107, MDT Functional Processes.		

2.1.5 RECEIVE, STORE, & TRANSFER BUS STOP DATA (F-108)

EDAPTS DATA OBJECT	ORIGIN ELEMENT	DESTINATION ELEMENT
<ObStopPointRecord>	E-107 MDT Functional Processes	E-701 On-Board Systems API
ASSUMPTIONS: This function requires that <SchMasterSchedulePackage> is available to element E-107, MDT Functional Processes.		

2.1.6 COLLECT VEHICLE ODOMETER DATA (F-111)

EDAPTS DATA OBJECT	ORIGIN ELEMENT	DESTINATION ELEMENT
<CptPTVehicleParameter>	E-107 MDT Functional Processes	E-701 On-Board Systems API
ASSUMPTIONS: None.		

2.1.7 PROVIDE NOTIFICATION OF STOP ARRIVALS AND DEPARTURES (F-112)

EDAPTS DATA OBJECT	ORIGIN ELEMENT	DESTINATION ELEMENT
<PiSchedAdherenceOffSched>	E-701	E-107
	On-Board Systems API	MDT Functional Processes
ASSUMPTIONS: This function requires that <SchMasterSchedulePackage> is available to element E-107, MDT Functional Processes.		

2.1.8 COLLECT DRIVER ID DURING LOGIN (F-113)

EDAPTS DATA OBJECT	ORIGIN ELEMENT	DESTINATION ELEMENT
<CPT_OperatorID>	E-107	E-701
	MDT Functional Processes	On-Board Systems API
ASSUMPTIONS: None.		

2.1.9 COLLECT ROUTE NUMBER DURING LOGIN (F-114)

EDAPTS DATA OBJECT	ORIGIN ELEMENT	DESTINATION ELEMENT
<PiSchedAdherenceOffSched>	E-107	E-701
	MDT Functional Processes	On-Board Systems API
ASSUMPTIONS: This function requires that <SchMasterSchedulePackage> is available to element E-107, MDT Functional Processes.		

2.1.10 PROVIDE REAL-TIME VEHICLE UPDATES (F-116)

EDAPTS DATA OBJECT	ORIGIN ELEMENT	DESTINATION ELEMENT
<RealTimeVehiclePosition>	E-107 MDT Functional Processes	E-701 On-Board Systems API
ASSUMPTIONS: This function requires that <SchMasterSchedulePackage> is available to element E-107, MDT Functional Processes.		

2.1.11 DECLARE ON-BOARD EMERGENCY (F-118)

EDAPTS DATA OBJECT	ORIGIN ELEMENT	DESTINATION ELEMENT
<ImEvent>	E-107 MDT Functional Processes	E-701 On-Board Systems API
<IM_EventLocation>	E-107 MDT Functional Processes	E-701 On-Board Systems API
ASSUMPTIONS: This function requires that <SchMasterSchedulePackage> is available to element E-107, MDT Functional Processes.		

2.1.12 MANUALLY COLLECT AND RECORD PASSENGER BOARDING (F-120)

EDAPTS DATA OBJECT	ORIGIN ELEMENT	DESTINATION ELEMENT
<ObStopPointRecord>	E-107 MDT Functional Processes	E-701 On-Board Systems API
<FC_RiderClassification>	E-107 MDT Functional Processes	E-701 On-Board Systems API
ASSUMPTIONS: This function requires that <SchMasterSchedulePackage> is available to element E-107, MDT Functional Processes.		

2.2 Central Site Software (CSS) to/from Roadside Information Display (RID)

2.2.1 PROVIDE ESTIMATED TIME UNTIL ARRIVAL AT STOPS (F-201)

EDAPTS DATA OBJECT	ORIGIN ELEMENT	DESTINATION ELEMENT
<TravInfoObStopPointRecord>	E-702	E-304
	Roadside Display API	RID Functional Processes
ASSUMPTIONS: This function requires that <SchMasterSchedulePackage> is available to element E-304, RID Functional Processes.		

2.2.2 PROVIDE DYNAMIC PUBLIC SERVICE INFORMATION AT STOPS (F-202)

EDAPTS DATA OBJECT	ORIGIN ELEMENT	DESTINATION ELEMENT
<RoadsideBannerMsg>	E-702	E-304
	Roadside Display API	RID Functional Processes
ASSUMPTIONS: This function requires that <SchMasterSchedulePackage> is available to element E-304, RID Functional Processes.		

2.3 Central Site Software (CSS) to External Traveler Information Services

2.3.1 PROVIDE API FOR TRANSIT TRAVELER INFORMATION (F-301)

EDAPTS DATA OBJECT	ORIGIN ELEMENT	DESTINATION ELEMENT
<TravInfoObStopPointRecord>	E-703 Traveler Information API	External data syncs
<RealTimeVehiclePosition>	E-701 On-Board Systems API	External data syncs
<SchMasterSchedulePackage>	E-703 Traveler Information API	External data syncs
ASSUMPTIONS: This function requires that <SchMasterSchedulePackage> is available to element E-304, RID Functional Processes.		

2.4 ATRMS to/from Central Site Software (CSS)

2.4.1 PROVIDE GEOLOCATION TRACKING DISPLAY (F-401)

EDAPTS DATA OBJECT	ORIGIN ELEMENT	DESTINATION ELEMENT
<RealTimeVehiclePosition>	E-701 On-Board Systems API	E-501 Vehicle Tracking Display
<ObStopPointRecord>	E-704 ATRMS API	E-501 Vehicle Tracking Display
<SchMasterSchedulePackage>	E-704 ATRMS API	E-501 Vehicle Tracking Display
<ImEvent>	E-704 ATRMS API	E-501 Vehicle Tracking Display
<ImEventLocation>	E-704 ATRMS API	E-501 Vehicle Tracking Display
ASSUMPTIONS: None.		

2.4.2 DISPLAY SCHEDULE ADHERENCE INFORMATION (F-402)

EDAPTS DATA OBJECT	ORIGIN ELEMENT	DESTINATION ELEMENT
<ObStopPointRecord>	E-704 ATRMS API	E-501 Vehicle Tracking Display
<SchMasterSchedulePackage>	E-704 ATRMS API	E-501 Vehicle Tracking Display
ASSUMPTIONS: None.		

2.4.3 DISPLAY PASSENGER BOARDING / ALIGHTING INFORMATION (F-403)

EDAPTS DATA OBJECT	ORIGIN ELEMENT	DESTINATION ELEMENT
<ObStopPointRecord>	E-704 ATRMS API	E-501 Vehicle Tracking Display
<SchMasterSchedulePackage>	E-704 ATRMS API	E-501 Vehicle Tracking Display
ASSUMPTIONS: None.		

2.4.4 HANDLE DRIVER EMERGENCY BUTTON DISPATCH & MANAGEMENT (F-404)

EDAPTS DATA OBJECT	ORIGIN ELEMENT	DESTINATION ELEMENT
<ImEvent>	E-701 On-Board Systems API	E-504 Emergency Management Display
<ImEventLocation>31	E-701 On-Board Systems API	E-504 Emergency Management Display
<RealTimeVehiclePosition>	E-704 ATRMS API	E-501 Vehicle Tracking Display
<SchMasterSchedulePackage>	E-704 ATRMS API	E-501 Vehicle Tracking Display
ASSUMPTIONS: None.		

2.4.5 PROVIDE STATISTICAL RIDERSHIP REPORTS FOR DISPATCH & MANAGEMENT (F-405)

EDAPTS DATA OBJECT	ORIGIN ELEMENT	DESTINATION ELEMENT
<ObStopPointRecord>	E-707	E-505
	CSS Functional Processes	Ridership Statistics Reporting
<SchMasterSchedulePackage>	E-707	E-505
	CSS Functional Processes	Ridership Statistics Reporting
ASSUMPTIONS: None.		

2.4.6 PROVIDE STATISTICAL SCHEDULE ADHERENCE REPORTS (F-406)

EDAPTS DATA OBJECT	ORIGIN ELEMENT	DESTINATION ELEMENT
<PiSchedAdherenceOffSched>	E-707	E-506
	CSS Functional Processes	Schedule Adherence Statistics
<SchMasterSchedulePackage>	E-707	E-506
	CSS Functional Processes	Schedule Adherence Statistics
ASSUMPTIONS: None.		

2.4.7 PROVIDE CONTROLS FOR DISSEMINATION OF BUS PASS LISTS (F-407)

EDAPTS DATA OBJECT	ORIGIN ELEMENT	DESTINATION ELEMENT
<FcMediaList>	E-805 Passenger Pass Lists	E-507 Bus Pass List Dissemination Controls
<FcElectronicTransaction>	E-701 On-Board Systems API	E-507 Bus Pass List Dissemination Controls
ASSUMPTIONS: None.		

2.4.8 PROVIDE CONTROLS FOR ROADSIDE BANNER MESSAGE DISPLAY (F-411)

EDAPTS DATA OBJECT	ORIGIN ELEMENT	DESTINATION ELEMENT
<RoadsideBannerMsg>	E-511 Roadside Administration Controls	E-304 RID Functional Processes
<SchMasterSchedulePackage>	E-702 Roadside Display API	E-511 Roadside Administration Controls
<ImEvent>	E-701 On-Board Systems API	E-511 Roadside Administration Controls
<PiSchedAdherenceOffSched>	E-701 On-Board Systems API	E-511 Roadside Administration Controls
ASSUMPTIONS: This function requires that <SchMasterSchedulePackage> is available to element E-304, RID Functional Processes.		

2.4.9 PROVIDE STATISTICAL BOARDING AND ALIGHTING REPORTS (F-413)

EDAPTS DATA OBJECT	ORIGIN ELEMENT	DESTINATION ELEMENT
<ObStopPointRecord>	E-707 CSS Functional Processes	E-505 Ridership Statistics Reporting
<SchMasterSchedulePackage>	E-707 CSS Functional Processes	E-505 Ridership Statistics Reporting
<ObDoorRecord>	E-704 ATRMS API	E-503 Passenger Boardings Display
ASSUMPTIONS: None.		

3. INTERFACE-SPECIFIC DATA OBJECTS

This section provides a listing of all Interface Specific Data Objects and indicates all Common Data Objects required for each one. Consider the data object <PiSchedAdherenceOffSched>, which is listed in section 3.7 below. This object contains various common data objects, including route_id, trip_id, and time_point_id. Each of these common data objects can be looked in Section 4 of this document, Common Data Objects to understand the details within the object.

3.1 FcElectronicTransaction

The FcElectronicTransaction object transmits information from the farecard machine to the MDT on the bus and then to the central dispatch regarding transactions with passengers. It contains information relating to the boarding transaction, the school id, and the account id of the card swept.

Note: Although this is an interface specific object, it is also used by other objects and thus is additionally listed as a common data object in section 4.9.

```
<FcElectronicTransaction>
  <boarding_transaction>
    <!-- Refer to FcBoardingTransaction -->
  </boarding_transaction>
  <institution_id>
    <!-- Refer to FC_InstitutionID -->
  </institution_id>
  <account_id>
    <!-- Refer to FC_AccountID -->
  </account_id>
</FcElectronicTransaction>
```

3.2 FcMediaList

The FcMediaList object represents a type of list that distinguishes valid and invalid ids for riders of the transit vehicle when their card is swiped. When the card is swiped, the farecard machine sends the card's information to the MDT to be verified. This object contains information relating to the type of farecard list, the type of rider, the type of monetary instrument used, and a list of valid account ids for comparison.

```
<FcMediaList>
  <list_type>
    <!-- Refer to FC_ListType -->
  </list_type>
```

```

<rider_class>
  <!-- Refer to FC_RiderClassification -->
</rider_class>

<monetary_inst_type>
  <!-- Refer to FC_MonetaryInstrumentType -->
</monetary_inst_type>

<account_id_list>
  <!-- Refer to a list of FC_AccountID -->
</account_id_list>

</FcMediaList>

```

3.3 ImEvent

The IMEvent object is generated when an emergency event occurs and is transmitted to the central software. IMEvent contains a Boolean for whether or not the emergency is active. It contains the ids for the dispatcher, source, route, and driver. IMEvent contains information related to the type of source the object is coming from, type of emergency, severity level, the type of acknowledgement of the emergency, and a description of the emergency. It gives the time the emergency is declared, emergency is acknowledged, a response occurs, and emergency terminated. Lastly, it transmits the location of the vehicle, the location time, and the location the event took place.

```

<ImEvent>

  <active>
    <!-- Refer to IM_Active -->
  </active>

  <source_id>
    <!-- Refer to IM_SourceID -->
  </source_id>

  <route_id>
    <!-- Refer to SCH_RouteID -->
  </route_id>

  <driver_id>
    <!-- Refer to CPT_OperatorID -->
  </driver_id >

  <dispatcher_id>
    <!-- Refer to CPT_OperatorID -->
  </dispatcher_id>

  <source_type>
    <!-- Refer to IM_SourceType -->
  </source_type>

```

```

<incident_type>
  <!-- Refer to IM_IncidentType -->
</incident_type>

<severity_level>
  <!-- Refer to CPT_SeverityLevel -->
</severity_level>

<description>
  <!-- Refer to IM_IncidentDescription -->
</description>

<request_time>
  <!-- Refer to IM_EventDateTime -->
</request_time>

<acknowledge_time>
  <!-- Refer to IM_EventDateTime -->
</acknowledge_time>

<response_time>
  <!-- Refer to IM_EventDateTime -->
</response_time>

</termination_time>
  <!-- Refer to IM_EventDateTime -->
</termination_time>

<acknowledge_type>
  <!-- Refer to IM_AcknowledgeType -->
</acknowledge_type>

<request_location>
  <!-- Refer to SpGeoPoint -->
</request_location>

<location_time>
  <!-- Refer to IM_EventDateTime -->
</location_time>

<event_location>
  <!-- Refer to IM_EventLocation -->
</event_location>

</ImEvent>

```

3.4 MDActivityList

The MDActivityList object generates a list of all things relating to the Activity of an MDT. It contains lists of the type of activities that the MDT has been performing, the routes the MDT has been on, the time the activities undertaken by the MDT occurred at, and a list of stop point records for the MDT.

```
<MDActivityList>

  Array lists of:
  <mdt_activity_type>
    <!-- Refer to MDT_ActivityType -->
  </mdt_activity_type>

  <mdt_activity_time>
    <!-- Refer to MDT_ActivityTime -->
  </mdt_activity_time>

  <day_type>
    <!-- Refer to SCH_DayType -->
  </day_type>

  <mdt_route>
    <!-- Refer to MDT_Route -->
  </mdt_route>

  <mdt_stop>
    <!-- Refer to MDTStopPointRecord -->
  </mdt_stop>

</MDActivityList>
```

3.5 MDLogRequest

The MDLogRequest object sends a log from the MDT to the central server with all information regarding the activity of an MDT. The MDLogRequest contains a list of MDT activities and a list of the boarding transactions for the MDT.

```
<MDLogRequest>

  <activity_list>
    <!-- Refer to MDActivityList -->
  </activity_list>

  <boarding_list>
    <!-- Refer to a list of FcBoardingTransaction -->
  </boarding_list>

</MDLogRequest>
```

3.6 ObStopPointRecord

The ObStopPointRecord object is transmitted from a transit vehicle to the central dispatch site upon departure from a stop, and contains information related to vehicle location, stop location, schedule adherence, boardings, and fares collected at the stop.

<ObStopPointRecord>

```
<agency_id>
  <!-- Refer to CPT_AgencyID -->
</agency_id>

<vehicle_id>
  <!-- Refer to CPT_PTVehicleID -->
</vehicle_id>

<time_table_version_id>
  <!-- Refer to SCH_TimeTableVersionID -->
</time_table_version_id>

<stop_point_zone_entry>
  <!-- Refer to OB_StopPointZoneEntry -->
</stop_point_zone_entry>

<stop_point_zone_exit>
  <!-- Refer to OB_StopPointZoneExit -->
</stop_point_zone_exit>

<door_record>
  <!-- Refer to ObDoorRecord -->
</door_record>

<sched_adherence_off_sched>
  <!-- Refer to PiSchedAdherenceOffSched -->
</sched_adherence_off_sched>
```

</ObStopPointRecord>

3.7 ObUpdate

The ObUpdate object represents all of the necessary software for an MDT to run that can be sent to MDT's from the central server for updating. The ObUpdate object contains information relating to the loader firmware, bin, wrapper, process and settings configuration files, and the version file.

<ObUpdate>

```
<loader>
  <!-- Refer to MDT_Loader -->
</loader>
```

```

<mdt>
    <!-- Refer to MDT_Bin -->
</mdt>

<mdt_wrapper>
    <!-- Refer to MDT_Wrapper -->
</mdt_wrapper>

<process>
    <!-- Refer to MDT_Process -->
</process>

<settings>
    <!-- Refer to MDT_Settings -->
</settings>

<version>
    <!-- Refer to MDT_Version -->
</version>

</ObUpdate>

```

3.8 PiSchedAdherenceOffSched

The PiSchedAdherenceOffSched object is used as a log for the schedule adherence of a bus on a given set of routes that is sent to central dispatch from the MDT. The object contains lists of information relating to the route number, the trip number, the name and id of the time point, the type of day, the stop point, the schedule's depart time, the vehicle's location at that time, and the amount of seconds off schedule.

Array List of:

<PiSchedAdherenceOffSched>

```

<route_id>
    <!-- Refer to SCH_RouteID -->
</route_id>

<trip_id>
    <!-- Refer to SCH_TripID -->
</trip_id>

<time_point_id>
    <!-- Refer to SCH_TimePointID -->
</time_point_id>

<time_point_name>
    <!-- Refer to SCH_TimePointName -->
</time_point_name>

<day_type>
    <!-- Refer to SCH_DayType -->
</day_type>

```

```

    <stop_point_sequence_no>
      <!-- Refer to SCH_StopPointSequenceNo -->
    </stop_point_sequence_no>

    <depart_time_scheduled>
      <!-- Refer to PI_DepartTimeScheduled -->
    </depart_time_scheduled>

    <vehicleLocation>
      <!-- Refer to SpGeoPoint -->
    </vehicleLocation>

    <off_schedule>
      <!-- Refer to PI_OffSchedule -->
    </off_schedule>
  </PiSchedAdherenceOffSched>

```

3.9 RealTimeVehiclePosition

The RealTimeVehiclePosition object represents the latitudinal and longitudinal inter-stop positions of a transit vehicle on route. RealTimeVehiclePosition contains a SpGeoPoint object that contains all necessary tracking information.

```

<RealTimeVehiclePosition>
  <GeoPoint>
    <!-- Refer to SpGeoPoint -->
  </GeoPoint>
</RealTimeVehiclePosition>

```

3.10 RoadsideBannerMsg

The RoadsideBannerMsg object represents custom messages to be sent to the Roadside Information Displays. RoadsideBannerMsg contains the message to be displayed.

```

<RoadsideBannerMsg>
  <message>
    <!-- Refer to RID_BannerMsg -->
  </message>
</RoadsideBannerMsg>

```

3.11 SchMasterSchedulePackage

The SchMasterSchedulePackage object contains all information regarding the schedule for a transit agency. This schedule can be transmitted from the central server to the MDT's as well as be used for verification of data sent by MDT's to the central dispatch. The object contains information relating to the version and period of validity of the schedule, a list of holidays and dates, a list of schedules for each route, and a list of all of the stop points for each stop.

```
<SchMasterSchedulePackage>

  <timeTableVersion>
    <!-- Refer to SchTimeTableVersion -->
  </timeTableVersion>

  <holidayList>
    <!-- Refer to a list of SchHoliday -->
  </holidayList>

  <masterScheduleList>
    <!-- Refer to a list of SchMasterSchedule-->
  </masterScheduleList>

  <stopPointList>
    <!-- Refer to a list of CptStopPoint -->
  </stopPointList>

</SchMasterSchedulePackage>
```

3.12 SchTimeTableVersion

The SchTimeTableVersion object is used by the MDT and the central server to confirm updates are made to the correct schedule when the updates are sent to MDT's from the server. This object contains the schedule version id, the schedule version name, and the activation and deactivation dates of the schedule.

```
<SchTimeTableVersion>

  <timetable_version_id>
    <!-- Refer to SCH_TimeTableVersionID -->
  </timetable_version_id>

  <timetable_version_name>
    <!-- Refer to SCH_TimeTableVersionName -->
  </timetable_version_name>

  <activation_date>
    <!-- Refer to CPT_ActivationDate -->
  </activation_date>

  <deactivation_date>
    <!-- Refer to CPT_DeactivationDate-->
  </deactivation_date>
```

```

    <agency_id>
      <!-- Refer to CPT_AgencyID >
    </agency_id>
  </SchTimeTableVersion>

```

3.13 SignUpdate

The SignUpdate object can be sent from the central server to the signs to update the sign code with the newest version. The SignUpdate object contains files relating to the assembly code of the sign.

```

<SignUpdate>
  <sign_assembly>
    Type: binary file
  </sign_assembly>
</SignUpdate>

```

3.14 TravInfoObStopPointRecord

The TravInfoObStopPointRecord object is sent from the Traveler Information API to External Data Syncs to provide information regarding departures from vehicle stops. This object contains information related to vehicle location, stop location, and schedule adherence at the stop.

```

<TravInfoObStopPointRecord>
  <agency_id>
    <!-- Refer to CPT_AgencyID -->
  </agency_id>

  <vehicle_id>
    <!-- Refer to CPT_PTVehicleID -->
  </vehicle_id>

  <time_table_version_id>
    <!-- Refer to SCH_TimeTableVersionID -->
  </time_table_version_id>

  <stop_point_zone_entry>
    <!-- Refer to OB_StopPointZoneEntry -->
  </stop_point_zone_entry>

  <stop_point_zone_exit>
    <!-- Refer to OB_StopPointZoneExit -->
  </stop_point_zone_exit>

```

```
<sched_adherence_off_sched>  
  <!-- Refer to PiSchedAdherenceOffSched -->  
</sched_adherence_off_sched>  
  
</TravInfoObStopPointRecord>
```

4. COMMON DATA OBJECTS

This section defines the format of each data object found in the Interface-Specific Data Objects listed in section 3 of this document. For example, the details for the `route_id` common data object, which is referenced in the `PiSchedAdherenceOffSched` Interface Specific Data Object, can be found in section 4.47, `SCH_RouteID`. The details of `SCH_RouteID` indicate that a Route ID will be a number valued between 0 and 100,000.

4.1 CptPTVehicleParameter

The `CptPTVehicleParameter` object contains the transit vehicle's mileage. It contains an element that determines whether or not the data is from the odometer, and it contains a value representing the mileage of the transit vehicle.

```
<CptPTVehicleParameter>
  <element>
    Range: 0 - 255
      0      - ERROR
      1      - ODOMETER
      2 - 254 - unspecified
      255    - UNSPECIFIED
  </element>
  <value>
    Range: 0 - 10000000
  </value>
</CptPTVehicleParameter>
```

4.2 CptStopPoint

The `CptStopPoint` object represents a point where public transportation customers board or arrive from a transit vehicle in revenue service. The object contains the name of the time point associated with the area, the id of the time point, and the gps location of the time point.

```
<CptStopPoint>
  <timePointID>
    <!-- Refer to SCH_TimePointID-->
  </timePointID>
  <timePointName>
    <!-- Refer to SCH_TimePointName -->
  </timePointName>
  <geoPoint>
    <!-- Refer to SpGeoPoint -->
  </geoPoint>
</CptStopPoint>
```

4.3 CPT_ActivationDate

The CPT_ActivationDate object contains the activation date of a schedule.

```
<CPT_ActivationDate>
```

```
  <!-- Date measured in seconds since January 1, 1970 - Unix epoch -->
```

```
  <CPT_ActivationDate_dt>
```

```
    Range: 0 - 2147483647
```

```
  </CPT_ActivationDate_dt>
```

```
</CPT_ActivationDate>
```

4.4 CPT_AgencyID

The CPT_AgencyID object contains a unique id number for each transit agency.

```
<CPT_AgencyID>
```

```
  <CPT_AgencyID_cd>
```

```
    Range: 0 - 32768
```

```
  </CPT_AgencyID_cd>
```

```
</CPT_AgencyID>
```

4.5 CPT_DeactivationDate

The CPT_DeactivationDate object contains the deactivation date of a schedule.

```
</CPT_DeactivationDate>
```

```
  <!-- Date measured in seconds since January 1, 1970 - Unix epoch -->
```

```
  <CPT_DeactivationDate_dt>
```

```
    Range: 0 - 2147483647
```

```
  </CPT_DeactivationDate_dt>
```

```
</CPT_DeactivationDate>
```

4.6 CPT_OperatorID

The CPT_OperatorID object contains a unique id for each transit staffperson that operates a transit vehicle.

```
<CPT_OperatorID>  
  <CPT_OperatorID_nbr>  
    Range: 0 - 4294967295  
  </CPT_OperatorID_nbr>  
</CPT_OperatorID>
```

4.7 CPT_PTVehicleID

The CPT_PTVehicleID object contains a unique id for each transit vehicle in a transit agency.

```
<CPT_PTVehicleID>  
  <CPT_PTVehicleID_nbr>  
    Range: 0 - 9999999  
  </CPT_PTVehicleID_nbr>  
</CPT_PTVehicleID>
```

4.8 CPT_SeverityLevel

The CPT_SeverityLevel object is a unique number assigned by a transit agency which defines the level of severity of an event that occurred or impacts transit property, facility, or service. A "1" assumes the greatest severity, and a 245 implies a low or absence of severity.

```
<CPT_SeverityLevel>  
  <CPT_SeverityLevel_nbr>  
    Range: 1 - 245  
  </CPT_SeverityLevel_nbr>  
</CPT_SeverityLevel>
```

4.9 FcBoardingTransaction

The FcBoardingTransaction object contains all of the information relating to a boarding rider and his/her transaction with the farecard machine. This contains the classification of the rider, the type of monetary instrument used, and the transaction result.

<FcBoardingTransaction>

```
<rider_classification>
  <!-- Refer to FC_RiderClassification -->
</rider_classification>

<monetary_instrument_type>
  <!-- Refer to FC_MonetaryInstrumentType -->
</monetary_instrument_type>

<transaction_result>
  <!-- Refer to FC_TransactionResult -->
</transaction_result>
```

</FcBoardingTransaction>

4.10 FcElectronicTransaction

The FcElectronicTransaction object contains all of the information relating to a transaction that occurs from the swipe card reader. This contains the boarding transaction object, the institution of the person whose card was swiped, and the account number of the person.

<FcElectronicTransaction>

```
<boarding_transaction>
  <!-- Refer to FcBoardingTransaction -->
</boarding_transaction>

<institution_id>
  <!-- Refer to FC_InstitutionID -->
</institution_id>

<account_id>
  <!-- Refer to FC_AccountID -->
</account_id>
```

</FcElectronicTransaction>

4.11 FC_AccountID

The FC_AccountID object is the account or customer identification.

```
<FC_AccountID>
  <FC_AccountID_txt>
    Range: 1 - 256 characters
  </FC_AccountID_txt>
</FC_AccountID>
```

4.12 FC_InstitutionID

The FC_InstitutionID object is the identification number of the institution of the customer.

```
<FC_InstitutionID>
  <FC_InstitutionID_nbr>
    Range: 0 - 99999999
  </FC_InstitutionID_nbr>
</FC_InstitutionID>
```

4.13 FC_ListType

The FC_ListType object describes the type of list an FC_MediaList is. It can be either a new list, addition, or a subtraction.

```
<FC_ListType>
  <FC_ListType_nbr>
    Range: 0 - 2
    - NEW_LIST
    - ADDITIONS
    - SUBTRACTIONS
  </FC_ListType_nbr>
</FC_ListType>
```

4.14 FC_MonetaryInstrumentType

The FC_MonetaryInstrumentType object describes the type of monetary instrument a customer used for the fare card. There are up to 255 different monetary instruments accepted.

<FC_MonetaryInstrumentType>

```
<FC_MonetaryInstrumentType_cd>
  Range: 1 - 255
    1          - bill
    2          - coin
    3          - token
    4          - ticket
    5          - debit
    6          - stored value
    7          - charge
    8          - hybrid
    9          - transit check
   10         - check card
   11 - 155 - reserved
   156 - 255 - local use
</FC_MonetaryInstrumentType_cd>
```

</FC_MonetaryInstrumentType>

4.15 FC_RiderClassification

The FC_RiderClassification object describes the type of rider entering the transit vehicle. There are up to 255 different types of riders accepted.

<FC_RiderClassification>

```
<FC_RiderClassification_nbr>
  Range: 1 - 255
    1          - regular
    2          - senior
    3          - child
    4          - student
    5          - youth
    6          - ADA customer
    7          - promotional
    8          - employee
    9          - retired employee
   10         - public assistance customer
   11 - 155 - reserved
   156 - 255 - local use
</FC_RiderClassification_nbr>
```

</FC_RiderClassification>

4.16 FC_TransactionResult

The FC_TransactionResult object describes the different states after a card has been swiped. There are up to 255 states that can be accounted for.

<FC_TransactionResult>

```
<FC_TransactionResult_cd>
  Range: 0 - 255
    0          - comment
    1          - successful transaction
    2 - 9      - reserved
    10         - read error
    11 - 19    - reserved
    20         - write error
    21 - 29    - reserved
    30         - verify error
    31 - 39    - reserved
    40         - validation status error
    41 - 49    - reserved
    50         - status error
    51 - 59    - reserved
    60         - other
    61 - 155   - reserved
    156 - 255 - local use
</FC_TransactionResult_cd>
```

</FC_TransactionResult>

4.17 IM_AcknowledgeType

The IM_AcknowledgeType describes the type or classification of an incident that occurs on a transit vehicle as it is acknowledged by the transit agency.

<IM_AcknowledgeType>

```
<IM_AcknowledgeType_cd>
  Range: 0 - 255
</IM_AcknowledgeType_cd>
```

</IM_AcknowledgeType>

4.18 IM_Active

The IM_Active object determines whether or not an incident is occurring.

```
<IM_Active>
  <active>
    Type: bool
    Range: TRUE/FALSE
  </active>
</IM_Active>
```

4.19 IM_EventDateTime

The IM_EventDateTime object describes the date and time an event occurs.

```
<IM_EventDateTime>
  <!-- Measured in seconds since January 1, 1970 - Unix epoch -->
  <IM_EventDateTime_tm>
    Range: 0 - 4294967295
  </IM_EventDateTime_tm>
</IM_EventDateTime>
```

4.20 IM_EventLocation

The IM_EventLocation describes information regarding the location of a transit vehicle during an emergency. The object contains the transit vehicle's id, the source device that detects the event, and the GPS location of the vehicle.

```
<IM_EventLocation>
  <vehicle_id>
    <!-- Refer to CPT_PTVehicleID -->
  </vehicle_id>

  <source_id>
    <!-- Refer to IM_SourceID -->
  </source_id>

  <time>
    <!-- Refer to IM_EventDateTime -->
  </time>

  <location>
    <!-- Refer to SpGeoPoint -->
  </location>
</IM_EventLocation>
```

4.21 IM_IncidentDescription

The IM_IncidentDescription object is a textual description of the incident that is occurring.

```
<IM_IncidentDescription>
  <IM_IncidentDescription_txt>
    Range: 1 - 256 characters
  </IM_IncidentDescription_txt>
</IM_IncidentDescription>
```

4.22 IM_IncidentType

The IM_AcknowledgeType describes the type or classification of an incident that occurs on a transit vehicle.

```
<IM_IncidentType>
  <IM_IncidentType_cd>
    Range: 1 - 255
  </IM_IncidentType_cd>
</IM_IncidentType>
```

4.23 IM_SourceID

The IM_SourceID object is the unique id of the source device that detects an event.

```
<IM_SourceID>
  <IM_SourceID_cd>
    Range: 0 - 65535
  </IM_SourceID_cd>
</IM_SourceID>
```

4.24 IM_SourceType

The IM_SourceType object describes the type of source device that detects an event.

```
<IM_SourceType>
  <IM_SourceType_cd>
    Range: 1 - 255
  </IM_SourceType_cd>
</IM_SourceType>
```

4.25 MDTStopPointRecord

The MDTStopPointRecord object describes all information recorded at a stop by the MDT. It contains information relating to when a transit vehicle enters and exits a stop point, and the transit vehicles schedule adherence. This object is used for logs.

```
<MDTStopPointRecord>

  <stop_point_entry>
    <!-- Refer to OB_StopPointZoneEntry -->
  </stop_point_entry>

  <stop_point_exit>
    <!-- Refer to OB_StopPointZoneExit -->
  </stop_point_exit>

  <schedule_adherence>
    <!-- Refer to PiSchedAdherenceOffSched -->
  </schedule_adherence>

</MDTStopPointRecord>
```

4.26 MDT_ActivityTime

The MDT_ActivityTime object describes the date and time of an action that occurs on the MDT.

```
<MDT_ActivityTime>

  <!-- Measured in seconds since January 1, 1970 - Unix epoch -->

  <MDT_ActivityTime_nbr>
    Range: 0 - 4294967295
  </MDT_ActivityTime_nbr>

</MDT_ActivityTime>
```

4.27 MDT_ActivityType

The MDT_ActivityType object describes the different types of actions that an MDT can perform. There are up to 50 accepted actions.

```
<MDT_ActivityType>
  <MDT_ActivityType_nbr>
    Range: 1 - 50
    1          - MDT Booted up
    2          - GPS Synchronized
    3          - Maintenance Mode activated
    4          - Logged on Route
    5          - Logs off Route
    6          - Reaches Stop
    7          - MDT loses GPS sync
    8 - 25    - reserved
    26 - 50   - local use
  </MDT_ActivityType_nbr>
</MDT_ActivityType>
```

4.28 MDT_Bin

The MDT_Bin object describes the binary for the Bin object that can be uploaded to an MDT.

```
<MDT_Bin>
  <MDT_bin_bn>
    Type: binary file
  </MDT_bin_bn>
</MDT_Bin>
```

4.29 MDT_Loader

The MDT_Loader object describes the binary for the Loader object that can be uploaded to an MDT.

```
<MDT_Loader>
  <MDT_loader_bn>
    Type: binary file
  </MDT_loader_bn>
</MDT_Loader>
```

4.30 MDT_Process

The MDT_Process object describes the process configuration file that can be uploaded to an MDT.

```
<MDT_Process>
  <MDT_process_bn>
    Type: binary file
  </MDT_process_bn>
</MDT_Process>
```

4.31 MDT_Route

The MDT_Route object describes the route number a transit vehicle is running.

```
<MDT_Route>
  <MDT_Route_nbr>
    Range: 0 - 1000
      0 - Not logged on to route
      1 - 1000 Route Number
  </MDT_Route_nbr>
</MDT_Route>
```

4.32 MDT_Settings

The MDT_Settings object describes the settings configuration file that can be uploaded to an MDT.

```
<MDT_Settings>
  <MDT_settings_bn>
    Type: binary file
  </MDT_settings_bn>
</MDT_Settings>
```

4.33 MDT_Version

The MDT_Version object describes the version configuration file that can be uploaded to an MDT.

```
<MDT_Version>
  <MDT_version_bn>
    Type: binary file
  </MDT_version_bn>
</MDT_Version>
```

4.34 MDT_Wrapper

The MDT_Wrapper object describes the binary for the Wrapper object that can be uploaded to an MDT.

```
<MDT_Wrapper>
  <MDT_wrapper_bn>
    Type: binary file
  </MDT_wrapper_bn>
</MDT_Wrapper>
```

4.35 ObDoorRecord

The ObDoorRecord object describes a record for all passengers that enter a transit vehicle. The object contains information relating to the number of passengers boarded, a list of each passengers boarding transaction as well as a list of their electronic transaction.

```
<ObDoorRecord>
  <passenger_boarding>
    <!-- Refer to OB_PassengerBoarding -->
  </passenger_boarding>
  <passenger_alighting>
    <!-- Refer to OB_PassengerAlighting -->
  </passenger_alighting>
  <boarding_transaction_list>
    <!-- Refer to a list of FcBoardingTransaction -->
  </boarding_transaction_list>
  <electronic_transaction_list>
    <!-- Refer to a list of FcElectronicTransaction -->
  </electronic_transaction_list>
</ObDoorRecord>
```

4.36 OB_PassengerBoarding

The OB_PassengerBoarding object describes the amount of passengers entering a transit vehicle.

```
<OB_PassengerBoarding>
  <OB_PassengerBoarding_qty>
    Range: 0 - 10000
  </OB_PassengerBoarding_qty>
</OB_PassengerBoarding>
```

4.37 OB_PassengerAlighting

The OB_PassengerAlighting object describes the amount of passengers exiting a transit vehicle. This value is helpful in determining how many people enter and exit at a given stop.

```
<OB_PassengerAlighting>
  <OB_PassengerAlighting_qty>
    Range: 0 - 10000
  </OB_PassengerAlighting_qty>
</OB_PassengerAlighting>
```

4.38 OB_StopPointZoneEntry

The OB_StopPointZoneEntry object describes the time at which a transit vehicle enters a stop point.

```
<OB_StopPointZoneEntry>
  <!-- Measured in seconds since January 1, 1970 - Unix epoch -->
  <OB_StopPointZoneEntry_tm>
    Range: 0 - 4294967295
  </OB_StopPointZoneEntry_tm>
</OB_StopPointZoneEntry>
```

4.39 OB_StopPointZoneExit

The OB_StopPointZoneExit object describes the time at which a transit vehicle leaves a stop.

```
<OB_StopPointZoneExit>
  <!-- Measured in seconds since January 1, 1970 - Unix epoch -->
  <OB_StopPointZoneExit_tm>
    Range: 0 - 4294967295
  </OB_StopPointZoneExit_tm>
</OB_StopPointZoneExit>
```

4.40 PI_DepartTimeScheduled

The PI_DepartTimeScheduled object describes the time a transit vehicle should depart a stop.

```
<PI_DepartTimeScheduled>
  <!-- Measured in minutes from midnight (HH*60+MM) -->
  <PI_DepartTimeScheduled_tm>
    Range: 0 - 1439
  </PI_DepartTimeScheduled_tm>
</PI_DepartTimeScheduled>
```

4.41 PI_OffSchedule

The PI_OffSchedule object describes the number of seconds a transit vehicle is off schedule.

```
<PI_OffSchedule>
  <!-- Measured in seconds from schedule departure time -->
  <PI_OffSchedule_tm>
    Range: 0 - 86400
  </PI_OffSchedule_tm>
</PI_OffSchedule>
```

4.42 RID_BannerMsg

The RID_BannerMsg object describes a custom banner message made in the ATRMS.

```
<RID_BannerMsg>
  <!-- Must conform to ASCII standards -->
  <RID_BannerMsg_txt>
    Range: 1 - 256 characters
  </RID_BannerMsg_txt>
</RID_BannerMsg>
```

4.43 SchHoliday

The SchHoliday object contains the information regarding a holiday that would be listed in the schedule. The object contains a description of the holiday as well as the date of the holiday with respect to the day of the year.

```
<SchHoliday>
  <description>
    <!-- Refer to SCH_HolidayDescription -->
  </description>
  <day_of_year>
    <!-- Refer to SCH_HolidayDate -->
  </day_of_year>
</SchHoliday>
```

4.44 SchMasterSchedule

The SchMasterSchedule object contains all of the trips on a route for the schedule. It contains a specified route and a list of trips for the route.

```
<SchMasterSchedule>
  <route>
    <!-- Refer to SchRoute -->
  </route>
  <trip_list>
    <!-- Refer to a list of SchTrip -->
  </trip_list>
</SchMasterSchedule>
```

4.45 SchRoute

The SchRoute object describes basic information regarding the designation and naming of a route. The object contains an identification number of the route, a route designator, and the text name of the route.

<SchRoute>

```
<route_id>
  <!-- Refer to SCH_RouteID -->
</route_id>

<route_designator>
  <!-- Refer to SCH_RouteDesignator -->
</route_designator>

<route_name>
  <!-- Refer to SCH_RouteName -->
</route_name>
```

</SchRoute>

4.46 SchTrip

The SchTrip object describes all of the information required to make a trip for a route on a schedule. The object contains the unique identification number of the trip, the type of day the trip takes place, the route the trip will run on, the time the trip begins, the time the trip ends, and a list of the trip time point headers.

<SchTrip>

```
<trip_id>
  <!-- Refer to SCH_TripID -->
</trip_id>

<day_type>
  <!-- Refer to SCH_DayType -->
</day_type>

<route_id>
  <!-- Refer to SCH_RouteID -->
</route_id>

<time_begin>
  <!-- Refer to SCH_TimeBegin -->
</time_begin>

<time_end>
  <!-- Refer to SCH_TimeEnd -->
</time_end>
```

```

    <trip_time_pt_hdr_list>
      <!-- Refer to a list of SchTripTimePtHdr-->
    </trip_time_pt_hdr_list>
  </SchTrip>

```

4.47 SchTripTimePtHdr

The SchTripTimePtHdr object describes all of the information needed to make a time point on a trip to be placed in a schedule. The object contains information relating to the unique identification number of the time point, the sequence number of the time point, the time a transit vehicle departs from the time point, how long a transit vehicle is to wait at a time point, and attributes regarding the time point.

```

<SchTripTimePtHdr>
  <time_point_id>
    <!-- Refer to SCH_TimePointID -->
  </time_point_id>
  <stop_point_sequence_no>
    <!-- Refer to SCH_StopPointSequenceNo -->
  </stop_point_sequence_no>
  <time_point_time>
    <!-- Refer to SCH_TripTimePtTime -->
  </time_point_time>
  <time_point_wait>
    <!-- Refer to SCH_TripTimePtWait -->
  </time_point_wait>
  <time_point_attribute>
    <!-- Refer to SCH_TripTimePtAttribute -->
  </time_point_attribute>
</SchTripTimePtHdr>

```

4.48 SCH_DayType

The SCH_DayType object is the type of day that a trip or route is run on in the schedule. There are up to 255 types of days accounted for.

<SCH_DayType>

```
<SCH_DayType_cd>
  Range: 1 - 255
    1      - Sunday
    2      - Monday
    3      - Tuesday
    4      - Wednesday
    5      - Thursday
    6      - Friday
    7      - Saturday
    8      - Holiday
    9      - Weekday
   10     - Weekend
   11     - Weekday, school closed
   12 - 149 - reserved
  150 - 245 - local use
  246     - Null
  247     - not used
  248     - reset to Null
  249     - Data Unavailable
  250     - Illegal calculation
  251     - Value Out of Range
  252     - Device malfunction (nothing returned)
  253     - Data no longer available
  254     - Data suppressed for security or privacy
  255     - Unspecified
</SCH_DayType_cd>
```

</SCH_DayType>

4.49 SCH_HolidayDate

The SCH_HolidayDate is the date that a holiday exists for use with the schedule to make holiday schedules.

<SCH_HolidayDate>

```
<!-- Measured in seconds since January 1, 1970 - Unix epoch -->

<SCH_HolidayDate_dt>
  Range: 0 - 4294967295
</SCH_HolidayDate_dt>
```

</SCH_HolidayDate>

4.50 SCH_HolidayDescription

The SCH_HolidayDescription is a short textual description of a day that is deemed a holiday in the schedule.

```
<SCH_HolidayDescription>
  <description>
    Range: 1 - 256 characters
  </description>
</SCH_HolidayDescription>
```

4.51 SCH_RouteDesignator

The SCH_RouteDesignator object describes a real world view of what route a transit vehicle is running.

```
<SCH_RouteDesignator>
  <SCH_RouteDesignator_txt>
    Range: 1 - 8 characters
  </SCH_RouteDesignator_txt>
</SCH_RouteDesignator>
```

4.52 SCH_RouteID

The SCH_RouteID object describes the number of the route a transit vehicle is running.

```
<SCH_RouteID>
  <SCH_RouteID_nbr>
    Range: 0 - 100000
  </SCH_RouteID_nbr>
</SCH_RouteID>
```

4.53 SCH_RouteName

The SCH_RouteName object describes the textual description for the name of a route a transit vehicle is running.

```
<SCH_RouteName>
  <route_name>
    Range: 1 - 17 characters
  </route_name>
</SCH_RouteName>
```

4.54 SCH_StopPointSequenceNo

The SCH_StopPointSequenceNo object is used to describe the order in which a time point is placed in a trip for a schedule.

```
<SCH_StopPointSequenceNo>
  <SCH_StopPointSequenceNo_nbr>
    Range: 0 - 65535
  </SCH_StopPointSequenceNo_nbr>
</SCH_StopPointSequenceNo>
```

4.55 SCH_TimeBegin

The SCH_TimeBegin object describes the time of day a trip begins on a route.

```
<SCH_TimeBegin>
  <!-- Measured in seconds from midnight -->
  <SCH_TimeBegin_tm>
    Range: 0 - 86399
  </SCH_TimeBegin_tm>
</SCH_TimeBegin>
```

4.56 SCH_TimeEnd

The SCH_TimeEnd object describes the time of day a trip ends on a route.

```
<SCH_TimeEnd>
  <!-- Measured in seconds from midnight -->
  <SCH_TimeEnd_tm>
    Range: 0 - 86399
  </SCH_TimeEnd_tm>
</SCH_TimeEnd>
```

4.57 SCH_TimePointID

The SCH_TimePointID object describes the unique identifier for a given time point.

```
<SCH_TimePointID>
  <SCH_TimePointID_nbr>
    Range: 0 - 1000000
  </SCH_TimePointID_nbr>
</SCH_TimePointID>
```

4.58 SCH_TimePointName

The SCH_TimePointName object is the textual description of a given time point.

```
<SCH_TimePointName>
  <SCH_TimePointName_txt>
    Range: 1 - 40 characters
  </SCH_TimePointName_txt>
</SCH_TimePointName>
```

4.59 SCH_TimeTableVersionID

The SCH_TimeTableVersionID object describes the unique identifier for the version number of a schedule.

```
<SCH_TimeTableVersionID>
  <SCH_TimeTableVersionID_nbr>
    Range: 0 - 65535
  </SCH_TimeTableVersionID_nbr>
</SCH_TimeTableVersionID>
```

4.60 SCH_TimeTableVersionName

The SCH_TimeTableVersionName object is a textual description of the schedule version.

```
<SCH_TimeTableVersionName>
  <SCH_TimeTableVersionName_txt>
    Range: 1 - 17 characters
  </SCH_TimeTableVersionName_txt>
</SCH_TimeTableVersionName>
```

4.61 SCH_TripID

The SCH_TripID is the unique identifier for the number of a trip for a schedule.

<SCH_TripID>

```
<SCH_TripID_nbr>  
  Range: 0 - 65535  
</SCH_TripID_nbr>
```

</SCH_TripID>

4.62 SCH_TripTimePtAttribute

The SCH_TripTimeAttribute object represents the various Boolean attributes that a stop on a trip would contain in the schedule. This object contains Booleans for whether or not it is a flagged stop, if there is a time point there, if it should report the time to the driver, if it should verify the location, if passengers will board there, if the stop is repeated on the trip, if it is a start or end point for a waypoint, or if it is a waypoint.

<SCH_TripTimePtAttribute>

```
<flag_stop>  
  Type: bool  
  Range: TRUE/FALSE  
</flag_stop>  
  
<time_point>  
  Type: bool  
  Range: TRUE/FALSE  
</time_point>  
  
<report_time_to_driver>  
  Type: bool  
  Range: TRUE/FALSE  
</report_time_to_driver>  
  
<location_verification>  
  Type: bool  
  Range: TRUE/FALSE  
</location_verification>  
  
<passenger_boarding>  
  Type: bool  
  Range: TRUE/FALSE  
</passenger_boarding>  
  
<repeated_stop_on_trip>  
  Type: bool  
  Range: TRUE/FALSE  
</repeated_stop_on_trip>
```

```

<start_wait_for_waypoint>
  Type: bool
  Range: TRUE/FALSE
</start_wait_for_waypoint>

<end_wait_for_waypoint>
  Type: bool
  Range: TRUE/FALSE
</end_wait_for_waypoint>

<waypoint>
  Type: bool
  Range: TRUE/FALSE
</waypoint>
</SCH_TripTimeAttribute>

```

4.63 SCH_TripTimePtTime

The SCH_TripTimePtTime object represents the time a trip takes place for a bus stop. SCH_TripTimePtTime contains a quantity representing the time a trip takes place.

```

<SCH_TripTimePtTime>
  <!-- Measured in minutes from midnight (HH*60+MM) -->

  <SCH_TripTimePtTime_tm>
    Range: 0 - 1439
  </SCH_TripTimePtTime_tm>
</SCH_TripTimePtTime>

```

4.64 SCH_TripTimePtWait

The SCH_TripTimePtWait object represents the time a bus waits at a bus stop on route. SCH_TripTimePtWait contains a quantity for the amount of time in a day that a bus must wait.

```

<SCH_TripTimePtWait>
  <!-- Measured in seconds from midnight -->

  <SCH_TripTimePtWait_tm>
    Range: 0 - 86399
  </SCH_TripTimePtWait_tm>
</SCH_TripTimePtWait>

```

4.65 SpGeoPoint

The SpGeoPoint object represents the location of a bus stop or a bus on route. SpGeoPoint contains latitude, longitude, angular heading of the direction of travel, and spatial coordinate system datum.

<SpGeoPoint>

```
<latitude>
    <!-- Refer to SP_Latitude -->
</latitude>

<longitude>
    <!-- Refer to SP_Longitude -->
</longitude>

<direction>
    <!-- Refer to SP_AngularDirection -->
</direction>

<datum>
    <!-- Refer to SP_Datum -->
</datum>
```

</SpGeoPoint>

4.66 SP_AngularDirection

The SP_AngularDirection object represents the angular heading of the direction of travel for a bus stop or a bus on route. SP_AngularDirection contains a quantity for the angular direction.

<SP_AngularDirection>

```
<!-- Measured in degrees = ddd -->

<SP_AngularDirection_qty>
    Range: 000 - 359
</SP_AngularDirection_qty>
```

</SP_AngularDirection>

4.67 SP_Datum

The SP_Datum object represents the spatial coordinate system used by the bus on route or at that stop. SP_Datum contains a quantity to represent one of three types of coordinate systems.

<SP_Datum>

```
<SP_Datum_cd>
  Range: 1 - 3
        1 - NAD27
        2 - NAD83
        3 - WGS84
</SP_Datum_cd>
```

</SP_Datum>

4.68 SP_Latitude

The SP_Latitude object represents the latitudinal location for a bus stop or a bus on route. SP_Latitude contains a quantity for the latitude that is interpreted as discussed below.

<SP_Latitude>

```
<!-- Made From:
      For North: (latitude_degrees + (latitude_minutes/360.0)) *
                  (2147483647/90)
      For South: - (latitude_degrees + (latitude_minutes/360.0)) *
                  (-2147483647/90)
-->
```

```
<!--
      NOTE: latitude_degrees and latitude_minutes in form of RMC of NMEA
            Standard
-->
```

```
<SP_Latitude_sp>
  Type: 9 - 10 digit number
  Range: 000000000 - 2147483647
</SP_Latitude_sp>
```

</SP_Latitude>

4.69 SP_Longitude

The SP_Longitude object represents the longitudinal location for a bus stop or a bus on route. SP_Longitude contains a quantity for the longitude that is interpreted as discussed below.

<SP_Longitude>

```
<!-- Made From:
      For East: (longitude_degrees + (longitude_minutes/360.0)) *
                (2147483647/180)
      For West: -(longitude_degrees + (longitude_minutes/360.0)) *
                (-2147483647/180)
-->

<!--
      NOTE: longitude_degrees and longitude_minutes in form of RMC of NMEA
            Standard
-->

<SP_Longitude_sp>
      Type: 9 - 10 digit number
      Range: 0000000000 - 2147483647
</SP_Longitude_sp>
```

</SP_Longitude>



EDAPTS

Smart Transit System



RFP 07-014

Exhibit C

Cal Poly Pomona EDAPTS Test Deployment

Operations Descriptions

Prepared for
California Partners for Advanced Transit and Highways
California Department of Transportation

Prepared by
Xudong Jia, Ph.D., P.E
California State Polytechnic University, Pomona

And

Jeff Gerfen
California Polytechnic State University, San Luis Obispo

Under PATH Contract TO 6403

June 8, 2007

1. INTRODUCTION

Transit users in small urban and rural communities face significant problems when using transit for primary transportation needs. The uncertainty of catching a bus that may come only once every half hour or longer to a rural bus stop is one of them. In response to this and other small transit problems, the California DOT (Caltrans) embarked on a research program entitled “Efficient Deployment of Advanced Public Transportation Systems” (EDAPTS) in the late 1990s. The goal was to make Intelligent Transportation System (ITS) technologies more available to the small transit community.

Having completed the initial research phase of this program, EDAPTS research is now ready for its last hurdle - commercialization. A new transitional test deployment of an updated EDAPTS concept system is now starting at the California State Polytechnic University, Pomona, California (Cal Poly Pomona). The Cal Poly Pomona EDAPTS Test Deployment system, hereinafter referred to as the Bronco Express EDAPTS system, is being designed, installed, operated, and tested through the sponsorship of the Federal Transit Administration (FTA) and California Department of Transportation (Caltrans). Through this test deployment, the commercialization of the EDAPTS concept systems can be further assessed and facilitated. Experience and knowledge gained from the test deployment will assist small transit properties in adopting the EDAPTS concept system.

A clear understanding of user needs for the Bronco Express EDAPTS system is critical to the success of this EDAPTS test deployment and commercialization project. The research team has worked with the Cal Poly Pomona’s Parking and Transportation Services (PTS), Associated Students, Inc. (ASI), University Senate, and Instructional and Information Technology (IIT) Division and established an Advisory Panel. On July 20, 2006, the research team and the Advisory Panel had a one-day workshop meeting on needs assessment of the Bronco Express EDAPTS System. The Advisory Panel provided extensive inputs on user needs and envisioned the future Bronco Express Smart Transit System. As a result of the workshop, an interim technical report that summarizes the Bronco Express EDAPTS operations description was developed (see EDAPTS Smart Transit System Operations Description, v3.0, 2006). On February 6, 2006, the research team and the Advisory Panel had another one-day workshop to review the interim report and identify the Bronco Express EDAPTS system performance requirements and priorities.

This report documents the outcomes of the February 6, 2007 workshop. It presents the most valued system characteristics of the Bronco Express EDAPTS system through the use of scored operational scenarios. The operational scenarios included in this report are down selected from those described in the initial release (V3.0) of the Operations Description report. The Advisory Panel members considered only scenarios with medium or high priority to be worthy of final consideration as deployable elements. These selected scenarios will allow the researchers to have an overall understanding of how the system will need to function in daily activities, better characterize the benefits that will be realized, and define any limitations that will have to be accommodated when the system is actually implemented.

This report is intended to communicate overall quantitative and qualitative EDAPTS system characteristics to users, developers, integrators, dispatchers, administrative staff and others. It is considered as the foundation for prioritizing customer needs and wants. It will be used to establish the baseline for the system requirements definition in the design process.

2. SYSTEM STAKEHOLDERS AND SUMMARY OF NEEDS

The first step in understanding the operational characteristics of the Bronco Express EDAPTS system is to identify stakeholders and determine current and future needs. The below section describes the stakeholders and summarizes the needs for the system.

2.1 Stakeholders

The Cal Poly researchers have developed a list of stakeholders who have an interest in the test deployment of EDAPTS on Bronco Express. The list of stakeholders includes:

- Cal Poly Pomona students, faculty, & staff who ride Bronco Express shuttle buses
- Cal Poly Pomona Parking and Transportation Services (PTS) management
- Laidlaw Transportation and its employees
- Cal Poly Pomona University Police
- Cal Poly Pomona Information Technology (IT) Department staff

2.2 Summary of Needs

The Cal Poly researchers and the Advisory Panel members have identified system and operational needs through a one-day workshop. These needs are summarized as follows:

A. Bronco Express Passenger Needs

Improve confidence in bus arrivals and departures at stops

The Advisory Panel members consider that improving Bronco Express on-time performance is one of the highest priorities in the test deployment of the Bronco Express EDAPTS system. Bus arrivals and departures at stops currently are not on-time. The Cal Poly Pomona's Poly Post, a Campus-wide newspaper that reports news, activities, and issues in the campus community, has revealed that untimely pick-ups at stops are the number-one problem of the current Bronco Express.

Maintain more evenly spaced bus arrivals at stops

The Bronco Express EDAPTS system should help buses maintain assigned schedules and spacing. A platoon of closely spaced buses arriving at stops is not desirable and does not maximize the efficiency of the Bronco Express services.

Make transit schedule and bus arrival information readily available and accurate

The Bronco Express EDAPTS system should have reliable shuttle schedules and bus arrival information for all periods of the day. Accurate timetables will allow passengers to time their arrival at a stop to more closely match the arrival of a specific bus, thereby

reducing waiting time in most cases. Passengers may also make informed decisions regarding waiting at the stop or walking to their destination.

B. Bronco Express Driver Needs

Implement a simple mechanism to operate fixed schedules on fixed routes

The current Bronco Express service employs 8 buses to provide students, faculty and staff with free shuttle services. It operates with a simple “policy schedule” for four fixed routes dictating that buses arrive at stops at every 10-15 minutes. Drivers do not think the existing headways work well for Bronco Express.

The Advisory Panel members feel that fixed schedules on the four fixed service routes might work better. The Bronco Express EDAPTS system should facilitate the use of fixed schedules.

Automate manual logging of information

The current Bronco Express relies heavily on drivers to manually collect various system and operational data when they start and end their service, run their routes, board passengers, and fuel their vehicle. There is a strong desire to automate the data collection process within the Bronco Express EDAPTS system. It is anticipated that the automated data collection will significantly relieve the workload of drivers and improve safety.

Implement a simple mechanism to quickly respond to incidents or accidents

The current Bronco Express relies on drivers to report to Cal Poly PTS coordinators and Laidlaw dispatchers via voice radio communications when an incident or accident occurs. Verbal communication might lead to certain confusion or misunderstanding of the incident as the PTS coordinators and Laidlaw dispatchers might take significant time to locate the bus with the incident. It is anticipated that a simple and quick response mechanism is needed to supplement the voice radio communications.

Having the actual positions of buses displayed on various system dispatch terminals will make it easier for support such as law enforcement to locate buses in the event of a breakdown or security situation.

Emergency mayday request to dispatch

Drivers need a method to easily and discretely send a request for law enforcement assistance when a person posing a danger to themselves or passengers is on-board. Such a system would enable Cal Poly Pomona or local law enforcement to intercept a bus in an emergency.

C. Cal Poly PTS Coordinator & Laidlaw Dispatcher Needs

Precisely know shuttle vehicle locations at all times

Dispatchers and coordinators will benefit by having real-time information regarding the location of all fleet vehicles. This information will help them better coordinate mechanical service calls, replacement of malfunctioning buses or ill drivers, and requests for information from the public. Anomalous situations such as natural disasters where large amounts of people might require movement may also benefit from this information. With the shuttle location information available, all dispatchers will have a good understanding of shuttle operations from the perspective of travel time, travel speed, shuttle spacing, and on-time performance.

Easily generate required reports for Cal Poly with minimal labor

The contract agreement between Cal Poly Pomona and Laidlaw requires that Laidlaw produce various operational reports and submit them to Cal Poly Pomona monthly. Laidlaw currently produces these reports manually. The Bronco Express EDAPTS system should automate this tedious and labor-intensive reporting task. The new system should automatically generate daily, monthly and annual reports.

D. System Performance Needs

The Bronco Express EDAPTS system should operate reliably and without significant communications delays to support the University shuttle services during typical and atypical operations. Typical operation includes daily running of all vehicles on routes. Atypical operation includes responding to drivers in distress and handling shuttle vehicles with accidents. It is anticipated that different ways of distributing Bronco Express operational information are needed. Display at bus stops, access to a web site, or dial-in to a pre-defined phone number might help passengers know where the shuttles are. Such redundant approaches would improve the EDAPTS system reliability. When message signs did not work at bus stops, passengers would have other ways to know the estimated time of a bus arriving at a certain stop.

E. System Maintenance Needs

Cal Poly Pomona staff assigned to the maintenance of the EDAPTS system requires a system that is reliable and simple to maintain, troubleshoot, and repair. The installed system should provide comprehensive diagnostics and clear maintenance documentation. All EDAPTS components should be easily replaceable. Whenever a component does not work, it can be easily replaced with a new one.

3. VISION

The Cal Poly Pomona EDAPTS Test Deployment system will aid in the operation of the Bronco Express shuttle service. Cal Poly Pomona students, staff, and faculty will have an easier time catching a Bronco Express bus due to improved predictability of bus arrivals and up-to-the-minute estimated arrival information at all stops. Bronco Express drivers will have an easier time maintaining proper headway on route, hence providing more regularly interspersed opportunities to board by eliminating platoons of closely arriving shuttles. Dispatchers and coordinators of Bronco Express shuttle buses will be provided with live information regarding the status, location, and loading of all vehicles, helping them to more effectively dispatch replacement buses and aid vehicles during breakdowns and emergency situations. Parking and Transportation Services management will have more complete knowledge of Bronco Express operations and resource utilization, allowing them to provide the best possible service for the least possible cost.

3.1 Expected Outcomes

The Cal Poly Pomona EDAPTS system shall:

- Reduce wait-times at stops by an average of two minutes through more predictable bus arrivals, more evenly spaced buses, and eliminated blocks of time where no bus is available to ride.
- Make waiting for a Bronco Express bus less stressful for passengers by keeping them informed of when the buses will arrive at the stops.
- Make riding Bronco Express safer due to less time waiting at bus stops during off hours. Wait time will be reduced by making arrival times more predictable, allowing passengers to better plan their arrival at a bus stop based on expected arrival times.
- Allow Bronco Express managers to optimize service through the use of quantifiable schedule adherence and passenger loading data for planning purposes.
- Save approximately 36 Laidlaw labor hours per month translating to \$2205 per month due to automatic generation of reports for Cal Poly Pomona Parking & Transportation Services.
- Save approximately 20 Cal Poly Parking labor hours per month translating to \$460 saved per month due to automatic generation of reports for Cal Poly Pomona Parking & Transportation Services. Such a system will aid both Cal Poly and Laidlaw through reduction of labor and improved report timeliness.
- Provide a controlled environment to test a process of engaging and empowering a typical small transit agency to purchase lower lifecycle cost ITS solutions in a methodical and efficient manner.

3.2 Expected System Characteristics

The Cal Poly Pomona EDAPTS system shall:

- Be easy to use, by passengers, drivers, dispatchers, and system managers.
- Be extensible, so that future features may be added for incremental cost.
- Provide reliable and timely data.
- Provide ADA compliant features and services.
- Be reliable and low cost in its operation.

4. OPERATIONAL SCENARIOS

Operational scenarios are step-by-step descriptions of how a system might operate and interact with its users under a given set of circumstances. In this report, scenarios are described in a manner that will allow the individuals involved in selecting, developing and using the Bronco Express EDAPTS system to walk through specific, situational events in order to gain a good understanding of the system.

Scenarios play important roles in the final system design of the Bronco Express EDAPTS Test Deployment system. They bind together all the individual parts of the system into a comprehensible whole. They help people understand how all the pieces should interact to provide useful operational capabilities. The detailed descriptions revealed in the scenarios provide comprehensible information for defining and prioritizing functional requirements, identifying and preparing operational prototypes to address user needs, and scoping the design framework for the EDAPTS system. Additionally, scenarios can also serve as the basis for developing the users' manual and the acceptance test plans of the EDAPTS system. Finally, the scenarios are useful tools for the integrators and the developers to verify that the system design will satisfy the users' needs and expectations.

The operational scenarios identified for the Bronco Express EDAPTS system are grouped in six categories:

- Riding the Bronco Express shuttles
- Driving the Bronco Express shuttles
- Dispatching drivers and vehicles
- Managing Bronco Express services
- Laidlaw management tasks
- Maintaining the EDAPTS system

4.1 Riding the Bronco Express Shuttles

Operational scenarios within this category describe how the Bronco Express EDAPTS system will provide transit information to students, professors, staff, and others as they plan to catch the bus and wait at bus stops.

4.1.1 CPP PROFESSOR WALKS UP TO BUS STOP TO CATCH A BUS

1. A professor walks up to a bus stop at 15 minutes before the hour to get a ride to his class. He knows that buses serving Routes A and B pass through this stop, however he would like to catch Route B. He is not too concerned about being late to his class, since he knows the Route B bus is scheduled to arrive at the stop 10 minutes before the hour and

will drop him off at his lecture destination at 5 minutes before the hour. This would allow him to be in his class by 3 minutes before the hour and ready to teach.

2. The *Bronco Express Automatic Transit Arrival Sign* installed at the bus stop provides him with information for all bus routes serving the stop by successively displaying the following messages:

Rt A OUT OF SERVICE

Rt B here in 6 minutes

Each message is displayed for approximately 7 seconds, then the pattern repeats.

3. The professor notes Route B is running a minute late, but feels comfortable since the information displayed on the Bronco Express EDAPTS bus sign has demonstrated itself to be accurate. He also notes that Route A is not running and wonders if it is because the bus has had a mechanical failure. He knows these are the most probable explanations because he read the promotional material distributed via email and in the CPP campus newspaper, Poly Post, when the new EDAPTS system was installed.
4. The Route B bus arrives as predicted at 9 minutes before the hour, the professor boards and the bus departs. The bus ends up gaining a little time on the way to his destination and arrives on schedule at 5 minutes before the hour.
5. The professor gets off the bus, walks to his classroom, and is on time.

4.1.2 CPP STUDENT IN THE LIBRARY NEEDING TO CATCH A BUS

1. A student is studying with a classmate in Building 17 (Engineering Building) and it is getting late. She needs to catch the Bronco Express home to the University Village housing complex but wishes to study for as long as is possible without missing the bus.
2. She checks the Bronco Express website and determines that Route A, which will take her to the Village, will be stopping in front of Building 17 at 10:45 PM. The Internet-based display also shows which buses are out of service, so she knows what all of her bus riding options are before packing up and heading to the bus stop. The student can see that Route A is on route and on schedule and indeed will be available to ride.
3. The student packs up her books at 10:35 PM, walks outside, and arrives at the Building 17 bus stop at 10:40PM. The large-format *Bronco Express Automatic Transit Arrival Sign* installed in front of Building 17 indicates that Route A will be arriving in 5 minutes, which makes her feel comfortable. It seems to her that more people are riding the bus; maybe because they have higher confidence getting a ride when they need it. This is also good news because students are driving less and that helps reduce traffic congestion on campus.

4.1.3 CPP STUDENT WITH A CELL PHONE NEEDING TO CATCH A BUS (POTENTIAL FUTURE FEATURE)

1. A student desiring to catch Route A from the Library dials the *Bronco Express Ride Hotline*. The call received by a voicemail system requests the stop number he wants to catch the bus at.
2. He looks up the stop number on his quick-reference laminated card he keeps in his wallet and enters it. The voicemail system responds in a pleasing voice:

Route C here in 20 minutes.

The student notices that the entire transaction takes only about 20 seconds, as the voicemail system is quick in both its request for stop number, and its response back to the student.

3. The student decides that he has enough time to get a bite to eat and catch Route C in 20 minutes. He picks up lunch and heads to the Library bus stop 15 minutes later, where the sign indicates that Route C will be arriving in 5 minutes. The student boards the shuttle and is on his way.

4.1.4 CPP STUDENT WITH A WEB-ENABLED CELL PHONE NEEDING TO CATCH A BUS (POSSIBLE FUTURE FEATURE)

1. A student is exiting a class and wants to catch route B at stop at Kellogg West outside her classroom.
2. The student uses her web-enabled phone or a PDA to access the Bronco Express website. She keys in the stop number and her phone displays the following information compactly on its Web screen.

Route B here in 8 minutes.

3. The student decides to head to the bus stop and arrives at the stop 3 minutes later. She finds the small-format *Bronco Express Automatic Transit Arrival Sign*, and looks at it, noticing two other students are also looking at the sign. The sign indicates that the Route B shuttle will arrive in 5 minutes.
4. The sign counts down, finally indicating that the shuttle will be arriving in 1 minute. Shortly thereafter the shuttle arrives. The student boards the bus and is on her way.

4.2 Driving the Bronco Express Shuttles

Operational scenarios within this category describe how the Bronco Express EDAPTS system will interact with drivers as they start their shift, drive on route, and end their shift.

4.2.1 CAL POLY OR LAIDLAW DRIVER STARTING DAY'S WORK

1. A Laidlaw driver arrives at work, and gets all information about the assignments and activities from the operations manager in the Laidlaw yard.
2. The driver walks out to his bus and powers it up. The *Mobile Data Terminal* in the driver's compartment is automatically powered up at this time and presents a login screen within two minutes.
3. The driver performs all his start-of-day checks and sits down in the driver's seat. He then selects "Driver Login" from the MDT menu of options, and selects his name from a list of possible drivers it displayed. The MDT automatically retrieves his employee ID from locally stored information on the MDT.
4. The driver is prompted for the vehicle's odometer reading and he enters it via the MDT's display and keypad. He does not have to enter other information such as date and time because the MDT determines this automatically from its GPS-synchronized internal clock.
5. The MDT then provides the driver with a list of possible routes, and he selects Route C as assigned by the dispatcher. This completes the login process and the MDT is ready for the driver to begin his route.
6. The MDT displays the stop where he should begin his route. The driver pulls out of the yard and heads for Cal Poly Pomona.
7. As soon as the driver reaches a predetermined speed of 5 MPH, the MDT starts displaying time in a large digit format and removes all other information from the display. Removal of detailed schedule adherence information from the MDT display helps prevent the driver from looking at the MDT while the shuttle is in motion. This reduces driver distraction and minimizes unsafe situations that are caused by inattention to the road ahead.
8. The driver arrives at Stop 5 or the beginning of Route C and the MDT indicates: "Arrived at Stop 5, departure in 6 minutes". He watches the MDT count down to zero minutes and then begins his route.

4.2.2 CAL POLY OR LAIDLAW DRIVER'S CHANGING SHIFT

1. A Laidlaw driver arrives at work and is transported to Cal Poly Pomona to relieve the driver currently servicing Route C. She meets the bus at a predefined location coordinated with the driver ahead of time.
2. The driver being relieved selects the "Driver Shift Change" function on his MDT. The MDT prompts for the vehicle's odometer reading, and completes the logout process once this is entered. The MDT then displays a shift login screen.
3. The relief driver then selects her name from the list of possible drivers, enters her personal ID number, confirms the vehicle's odometer reading, and confirms "Route C" as the route she will be driving.

4. The MDT then provides her with the stop location she should begin her route at and once she reaches it, the MDT indicates how many minutes should be waited before she departs.
5. The MDT automatically collects all pertinent data regarding this shift change (including date, time, odometer, route, location, and drivers involved), and writes it to permanent storage and transmits it to the central site. This information will be available for driver shift report generation later on.

4.2.3 CAL POLY OR LAIDLAW DRIVER LOGOUT

1. A driver is the last person driving Route C for the day and her shift corresponds to the end of service for this route. The MDT indicates that service for Route C for the day is complete and that she should proceed to the yard after discharging any remaining passengers on-board. The MDT automatically determines that she is at the end of her day through the use of its standard clock and location positioning equipment (GPS), and records the deadhead miles.
2. Upon arrival at the yard, the driver parks her bus and selects the “End Shift” function on the MDT. The MDT requests the vehicle’s odometer reading, and after the driver inputs it, completes the logout process.
3. The MDT then writes information regarding the driver logout to its permanent storage and transmits it to the central site for later report generation.

4.2.4 CAL POLY OR LAIDLAW DRIVER ON ROUTE AND PICKING UP PASSENGERS

1. A driver on Route C, arrives at the Library on the Cal Poly campus as part of his route. The MDT display indicates that he has arrived at the Library, what the current time is, and how many minutes remain until he should depart the stop.
2. The driver presses a “CPP Rider” button on the MDT each time a passenger boards. He is pleased to be doing this, as he recalls how he used to have to record this information manually using a pencil and paper. He now no longer has to complete any paperwork regarding passenger boarding.
3. The last passenger waiting at the stop boards the bus. The driver checks his MDT and it indicates that he should depart in 1 minute. He waits one minute, closes the door and departs. The driver is also enjoys having the MDT coordinate his departure time as he no longer has to worry about manually maintaining proper spacing with the other bus on Route C. Once the bus is in motion, the MDT blanks its display and shows only the current time in easy to read digits that are about ¾ inch tall.

4.2.5 CAL POLY OR LAIDLAW DRIVER ON ROUTE & PICKING UP RIDERS WITH AUTOMATIC PASSENGER COUNTER (POSSIBLE FUTURE FEATURE)

1. A driver is driving one of the buses with an automatic passenger counter (APC) installed.

When she opens either or both doors at stops, she sees that the “Riders On Board” counter display automatically increases when riders board her bus. She also sees that the counter decreases when riders get off the bus.

2. The driver feels very happy because she does not need to count passengers manually at each stop and report the counts back to the dispatch offices. She understands that the APC is doing all of his counting work behind the scenes.
3. The driver also feels that the APC reduces her workload and stress significantly, allows her to pay more attention to passenger needs, and increases safety.

4.2.6 DANGEROUS SITUATION ON BUS

1. A driver is driving Route A and determines that a dangerous person is on the bus. The person is harassing passengers, threatening the driver, and making obscene remarks. The driver does not know exactly how dangerous the person is, but is hesitant to call for help on the radio for fear of being assaulted.
2. The driver waits until the dangerous person is yelling at the rear of the bus and presses the Driver’s Emergency Button that is installed below her left thigh on the bus. The driver holds the button down for the required one and a half seconds and a silent emergency signal is sent from the MDT to the dispatch center via the communications link.
3. Dispatchers at both centers are alerted to the emergency condition via audible and visual alarms on their EDAPTS consoles. On both consoles the emergency alert is given a priority, locking out all normal functions. In addition, the bus having the emergency is automatically put into a “Tracking Mode”. In this mode the bus location is transmitted to the dispatch center every 15 seconds until an authorized individual clears the alarm.
4. The Laidlaw dispatcher, who first sees the problem, begins handling the alarm; taking responsibility for the situation and unlocking the remaining dispatch console at Cal Poly Pomona.
5. The Laidlaw dispatcher clicks on a GUI button that is presented and then begins a preprogrammed emergency mode dialog with the driver on the bus involved. This includes asking a coded question about the bus operational status. Based on the driver’s correct response to the question, the dispatcher determines that the alert is a real situation and promptly dispatches the emergency responders to the bus location as displayed on his console screen.
6. By watching the GPS location data from the bus, the dispatcher keeps the emergency responders up to date on the bus current location to make sure no time is wasted in trying to find it.
7. Once the situation is over, the driver and the dispatcher talk about what happened and feel confident that the new emergency system helped prevent a potentially dangerous

situation from getting out of hand. The new procedure, with its coded message protocol for false alarms, prevents unnecessary dispatch of emergency personnel and assures prompt response in an emergency.

4.2.7 GOING ON BREAK

1. A Laidlaw driver is driving on Route C. The MDT indicates his scheduled arrival time at each stop as he arrives at it.
2. Upon arriving at the location for the driver's scheduled break, the MDT indicates "Driver Rest Stop" and then begins counting down the minutes until he is to depart and begin driving his route. He changes the vehicles electronic route sign to say "Not In Service".
3. Upon seeing the MDT count down to zero, the driver changes the vehicle's electronic route sign to say "Route C" and begins driving the route. The MDT begins reporting arrivals at stops as he progresses along his route.

4.2.8 FUELING

1. A driver is assigned to drive Route B. After he finishes his eight-hour service, he drives his Laidlaw bus to the University's fuel station and begins refueling the vehicle.
2. Once fueling is complete, the driver selects the "Fueling" function on the MDT menu list. The MDT display shows a dialog on which he enters the number of gallons filled and the odometer reading of the bus. The new system does not require any paper-based record keeping, but rather logs all information automatically and transmits it to the central site so that it can be incorporated into monthly reports.

4.3 Dispatchers Drivers and Vehicles

Operational scenarios within this category describe how the Bronco Express EDAPTS system will interact with dispatchers.

4.3.1 DISPATCHERS AT WORK

1. Upon arriving at work, a Laidlaw dispatcher powers up his EDAPTS dispatch console. He selects the Fleet Status section on his console as he does everyday, and makes both a Bronco Express System map and a Fleet Status table available for his dispatching activities. The Fleet Status table looks like the one below:

ROUTE	OPERATOR	STATUS	LAST STOP	NEXT STOP	LOADING
A-1	State Driver's Name	on route	Rose Garden	Building 1	15/24
A-2	Laidlaw Driver's Name	on route	Building 1	Rose Garden	10/24
B-1	Laidlaw Driver's Name	on break	Kellogg West	Collins School	0/24
B-2	Laidlaw Driver's Name	on route	Building 1	Rose Garden	5/16
C-1	Laidlaw Driver's Name	on break	Market Place	Environmental Design	0/24
C-2	Laidlaw Driver's Name	on route	Campus Center	Building 77	1/16

The dispatcher knows that the system map will update its bus location status every minute. The Fleet Status table will update its information whenever a bus arrives or departs a stop or a driver break location.

The dispatcher also knows that the State dispatcher has the same information available to them. This helps them communicate over the telephone more effectively regarding vehicle operations.

2. Around 12:15 PM, the Laidlaw dispatcher receives a radio message from the driver on Route C. The driver prefers to take a "short" break at the "Building 29" bus stop since he needs to go to a restroom as quickly as possible. The "Building 29" bus stop is not the scheduled bus stop for a break. However it is the bus stop closest to a restroom the driver knows.
3. The dispatcher accepts his request. He notices that the bus on Route C does not move during the driver's short break.
4. Around 12:35 PM, the driver on Route C finishes his break and starts his service. The dispatcher notices that the bus on Route C is moving again on the system map.

4.3.2 DISPATCHERS KNOW WHERE VEHICLES ARE

1. A dispatcher is on duty, and receives a phone call from the wife of a Route B driver. His wife needs to go to hospital to deliver her first baby. The dispatcher needs notify the driver and to send a substitute to relieve him.
2. The dispatcher selects the system map and the Fleet Status table on the console to determine the location of the driver she is trying to find.
3. The dispatcher communicates with the substitute driver and instructs her where and when to intercept the bus so that she can take over the route. She informs the original driver via a dedicated radio channel that his wife is on the way to the hospital and where the

substitute driver will relieve him.

4. When the drivers meet up, the original driver logs off from the MDT and the substitute driver logs into the EDAPTS system. The substitute driver reports to the dispatcher she is logged on and the route is back in service.
5. The dispatcher selects the Fleet Status function on the EDAPTS console and sees the driver's name has changed on Route B.

4.3.3 DISPATCH BUS WITH SERIOUS MECHANICAL FAILURE

1. A State dispatcher is on duty. He receives a phone message from a Laidlaw dispatcher indicating there is a mechanical failure on a Laidlaw bus. The failed bus is stuck on the road and cannot continue to service Route C.
2. Both State and Laidlaw dispatchers look at the Bronco Express system map and find out the location where the failed bus is.
3. After talking with the driver of the failed bus using the radio system, the LaidLaw dispatcher believes the mechanical failure is a serious one. He decides to replace the failed bus by a substitute one.
4. The Laidlaw dispatcher updates the Fleet Status table and changes the status of the bus on Route C from "On Route" to "Mechanical failure; Replacement Bus Expected." The change quickly appears on all EDAPTS system consoles (including the State dispatcher's) and indicates that a vehicle problem is ongoing.

ROUTE	OPERATOR	STATUS	LAST STOP	NEXT STOP	LOADING
A-1	State Driver's Name	on route	Rose Garden	Building 1	15/24
A-2	Laidlaw Driver's Name	on route	Building	Rose Garden	7/24
B-1	Laidlaw Driver's Name	on break	Kellogg West	Collins School	0/24
B-2	Laidlaw Driver's Name	on route	Building 1	Rose Garden	4/16
C-1	Laidlaw Driver's Name	on route	Market Place	Environmental Design	6/24
C-2	Laidlaw Driver's Name	Mech. Failure; Replacement Bus Expected	Building 29	Building 89	0/16

5. The Laidlaw dispatcher informs the Service Manager in the Laidlaw repair shop of the bus failure and asks a temporary bus driver to drive the substitute bus to replace the failed bus. The temporary driver drives the substitute bus to Cal Poly Pomona.

6. Also he sends a mechanic to go with the temporary driver. The mechanic makes a thorough diagnosis of the failed bus and informs the Laidlaw dispatcher that a big tow truck is needed to get the failed bus into the repair shop. The Laidlaw dispatcher then sends a big tow truck to get the failed bus in the Laid Law’s repair shop.
7. The Route C driver gets the replacement bus and logs in the EDAPTS system for the substitute bus. Once the login is successful, he updates the Route C’s bus status within the Fleet Status table. The Fleet Status table then may look like the below one:

ROUTE	OPERATOR	STATUS	LAST STOP	NEXT STOP	LOADING
A-1	State Driver’s Name	on route	Rose Garden	Building 1	5/24
A-2	Laidlaw Driver’s Name	on route	Building	Rose Garden	8/24
B-1	Laidlaw Driver’s Name	on route	Kellogg West	Collins School	10/24
B-2	Laidlaw Driver’s Name	on route	Building 1	Rose Garden	14/16
C-1	Laidlaw Driver’s Name	on route	Market Place	Environmental Design	16/24
C-2	Laidlaw Driver’s Name	on route	Building 29	Building 89	10/16

8. When the Fleet Status table shows the failed bus is replaced, both the State dispatcher and the LaidLaw dispatcher know how long the bus replacement takes. They simply push a button called “Incident Clearance Report” on their console. They know Route C has been out of service for 41 minutes.

4.4 Managing Bronco Express Service

Operational scenarios within this category describe how to manage the Bronco Express service.

4.4.1 USING PASSENGER LOADING REPORTS TO OPTIMIZE VEHICLE SIZE

1. The Bronco Express manager has noticed that Route C often seems to have many standbys, regardless of time of day.
2. The manager selects the Ride Report section of the EDAPTS system console and selects the daily, monthly and yearly passenger loading reports for all routes. The reports list the peak loads, the peak hours and other temporal characteristics of all the service buses.
3. The manager uses this data to determine that the bus assigned to Route C often has 5 to 10 more people on-board than its capacity. He plans to use this information to help in his selection of the new bus that is planned for purchase that year.

4.4.2 USING SCHEDULE ADHERENCE REPORTS TO ADJUST SCHEDULE (POTENTIAL FUTURE FEATURE)

1. The Bronco Express manager has heard complaints from student representatives of the Associated Students, Inc. (ASI) that the bus schedule does not provide adequate service at the new parking structure opened recently. The manager recalls that the EDAPTS system has a tool to help him adjust schedules based on the actual travel times experienced.
2. The manager clicks the Schedule section of the EDAPTS console. He selects the Adjust button.
3. The EDAPTS system provides him with a recommended new bus schedule. The adjusted schedule is developed based on the statistical patterns of the actual travel time of buses on that route.
4. The manager prints out the revised schedule and compares it with the one currently used for the Bronco Express. He feels the revised one reflects the traffic impacts of the new parking structure. He decides to adopt the revised schedule and implement it in the Bronco Express.
5. He simply selects the revised schedule and pushes the “ACCEPT” button. The Bronco Express bus serving that route is then placed on the revised schedule via the normal schedule adjustment process.

4.5 Laidlaw Management Tasks

Operational scenarios within this category describe how the EDAPTS system can help manage the Laidlaw Management Tasks.

4.5.1 PROVIDING THE MONTHLY REPORT TO CAL POLY

1. The Laidlaw Transit Services manager logs into the EDAPTS system and selects Ride Reports on the console.
2. He enters a start date and an end date for the reporting period, selects routes to include in the report, and selects 1) passengers boarding at each stop by month and 2) total passenger counts by month.
3. The manager then selects the output report format as CSV (comma separated variable) rather than Adobe PDF. With all selections and parameters entered, the manager hits the “RUN REPORT” button on the console.
4. A monthly report that satisfies Cal Poly Pomona reporting requirements is automatically generated. The manager prints the report, makes a copy for himself, and mails it to Cal Poly Pomona Parking and Transportation Services.

4.6 Maintaining EDAPTS System

Operational scenarios within this category describe how to maintain the EDAPTS system.

4.6.1 SCHEDULE AND ROUTE UPDATES

1. An administrative assistant working for PTS maintains the Bronco Express schedule. His work includes analyzing schedule adherence reports generated by the EDAPTS system, looking at requirements for adding new stops, changing existing stops or removing stops. Typically, this information is used to generate revised route maps for the system and that is what he's doing today.
2. After the assistant has finalized a new system schedule, he then logs into the EDAPTS system as a schedule manager. In this role, he is able to modify route timetables for the system and create a new schedule.
3. Upon creation of this electronic version of the schedule, the assistant hits a button that automatically deploys the schedule to all Mobile Data Terminals (MDTs) and real-time bus arrival signs in the fleet. There is no need to send a service technician out to the buses or signs in order to do the update.

4.6.2 ADDITION OF NEW STOPS ON A ROUTE

1. An administrative assistant working for PTS needs to create a new stop in the system as part of creating a new schedule.
2. He coordinates with Laidlaw to have a driver survey the new stop.
3. The driver assigned to the task drives to the new stop location and sets his Mobile Data Terminal (MDT) into Stop Survey mode, which reports the GPS coordinates to the driver.
4. The driver records these coordinates on the Stop Survey Form and reports them to the administrative assistant later that day.
5. The assistant uses the schedule tool in the EDAPTS system to create a new stop, entering the GPS coordinates from the Stop Survey Form when prompted to do so. The schedule tool then creates a new schedule utilizing the newly created stop.
6. Upon creation of this electronic version of the schedule, the assistant hits a button that automatically deploys the schedule to all Mobile Data Terminals and real-time bus arrival signs in the fleet.

4.6.3 ON-BOARD HARDWARE MAINTENANCE

1. A maintenance technician is assigned to maintain EDAPTS system hardware. According to the EDAPTS maintenance manual, the technician needs to periodically test all EDAPTS hardware to ensure complete and proper function. If a hardware device does not

work, he needs to conduct on-site troubleshooting, repair and replace damaged or failed components. He also needs to work with the vendors of the EDAPTS system to get sufficient spare hardware.

2. One day, around 9:30 AM, he receives a radio message from the Laidlaw dispatcher indicating that the magnetic card reader does not work on the bus that serves Route B.
3. He looks the Bronco Express system map and knows when and where he can intercept the problem bus.
4. He goes onto the bus and diagnoses a failed card reader. He finds that the card reader has an electrical problem. He needs to replace it by a spare one. He quickly de-mounts the failed card reader and re-mounts the spare one.
5. He conducts a serious of testing on the replaced card reader and ensures all the EDAPTS components related to the card reader are working properly.

4.6.4 DISPATCH CONSOLE MAINTENANCE

1. A computer technician is assigned to maintain the EDAPTS dispatch console(s). According to the EDAPTS maintenance manual, the technician needs to periodically test all EDAPTS software to ensure complete and proper function. If a malfunction occurs on an EDAPTS dispatch console, he needs to conduct troubleshooting and repair damaged or failed functions. He is responsible for installing any necessary EDAPTS or base operating system software and conducting security updates when the updates become available. He also needs to periodically back up and expunge EDAPTS databases.
2. One day, around 10:00 AM, the technician receives a phone call from the State dispatcher saying that the dispatch console has some problems. The Bronco Express system map cannot appear on the dispatch console.
3. The technician goes to the dispatcher's office and finds out that the Bronco Express system map file has been somehow deleted.
4. He reinstalls the EDAPTS dispatch console software, tests all the EDAPTS dispatching functions and makes sure all the functions work fine.
5. The dispatcher is happy with the quick response from the technician.

4.6.5 VEHICLE TO CENTRAL DISPATCH COMMUNICATION LINK FAILS

1. A computer technician receives a call from the PTS Bronco Express Shuttle Service

Manager saying that

- a) All dispatch and administrative consoles indicate: “No Current Fleet Data Available”.
 - b) All Web-interfaces and transit signs indicate: “No Current Fleet Data Available, Please Consult Schedule.”
2. The CPP EDAPTS technician investigates the problem to determine a cause of failure. He is aware that these could include failed communications or computer equipment. He has a comprehensive User’s Manual that includes troubleshooting guidelines and various system diagnostic tools to assist in assessing problems. He also notifies the communications system provider to assist in troubleshooting.
 3. Once he has located the failure, he utilizes an available cache of spare parts and makes the required repair. Prior to finishing, the technician ensures all consoles, signs, and Web-interfaces are working properly.

4.6.6 ON-BOARD EQUIPMENT FAILS

1. The driver on Route B notices a message on the MDT indicating that the automatic passenger counter (APC) has failed.
2. The driver attempts to correct the system error by cycling system power OFF and then back ON. After doing this, the system error still exists and the driver calls dispatcher to inform them that an on-board equipment failure exists. The MDT is still partially operational and has an active communications link, so the driver uses the MDT controls to send a “Failed On-Board Component” message to dispatcher.
3. The CPP EDAPTS technician is dispatched to the bus with supply of spare parts and diagnostic tools to determine if the problem can be quickly rectified via removal and replacement of parts or by a system reconfiguration. The technician is unable to do an on-route repair, so the problem is noted in system log and the technician returns to the shop.
4. That night, the technician locates the problem, replaces the failed parts and generates the Return To Vendor (RTV) paperwork so that they may be returned to the supplier for repair.

4.6.7 TRANSIT SIGN FAILS

1. The transit sign at Stop 5 displays an “Out of Service” message indicating that it has failed. The driver on Route A1 reports the message to dispatcher via the voice radio system. The Customer Service representative has also advised the dispatcher that a few students have called reporting the sign’s message.
2. The EDAPTS technician is dispatched to the sign with supply of spare parts and diagnostic tools. The technician finds the problem and replaces a failed power supply.

The problem and its resolution are noted in system log and the failed part is brought back to the shop so that it can be returned to the vendor for repair.

3. After returning to the office, the technician generates the Return To Vendor (RTV) paperwork so that the power supply can be returned to the supplier for repair.
4. The on-site repair capability has saved at least six hours of labor by not having to remove the sign, take it to the shop and then reinstall the sign once the repairs have been completed.

4.6.8 COMPUTER CONSOLE OR SERVER FAILS

1. A dispatcher notes a problem with his console has occurred when he sees a warning message on the Schedule Adherence GUI. A technician is requested to repair the system.
2. The CPP EDAPTS technician investigates problem using the troubleshooting guidelines and system diagnostic tools inside the EDAPTS User's Manual. She determines the cause of failure to be a software configuration error. The error occurred during a recent software update.
3. After correcting the problem and verifying that proper operation has been restored, she checks all other consoles and makes sure they are not affected. Finding no other problems, she notes the failure in the system log for possible future use in trend analysis.

5. BRONCO EXPRESS EDAPTS SYSTEM PERFORMANCE REQUIREMENTS AND PRIORITIES

The Cal Poly researchers and the Advisory Panel members reviewed all the operational scenarios listed in Section 4, identified Bronco Express EDAPTS system performance requirements and placed a scoring value to each requirement from the view of users.

The scoring value ranges from 1 – 10, where a value of 10 indicates that the subject performance requirement is very important to the EDAPTS system. A value of 1 indicates the subject performance requirement is not needed in the EDAPTS system. A value of 6 indicates that the function would likely be desired in the future, so system design should incorporate it.

Table 5.1 lists the Bronco Express EDAPTS system performance requirements and priorities derived from the operational scenarios.

TABLE 5-1 BRONCO EXPRESS EDAPTS SYSTEM PEROFORMANCE REQUIREMENTS AND PRIORITIES

Scenario	Operational Characteristics	Score (1-10)	Comments
4.1.1 CPP Professor Walks Up to Bus Stop to Catch a Bus	<ol style="list-style-type: none"> 1. Reliable fixed timetable 2. Publication of timetable via different media 3. Real time update at bus stops 	<p>10</p> <p>10</p> <p>10</p>	<p>Transit signs should only display buses arriving at specific stops.</p> <p>Publication of timetable via different media is needed.</p> <p>Real-time updates at bus stops are <u>very</u> important.</p> <p>Totally, CPP has three routes and 31 stops. Route A, B, and C has stops 9, 16, and 6 stops respectively. Some stops are overlapping stops.</p> <p>Overlapping stops should have large signs. Rotation of messages for different routes is expected at these large signs. Smaller signs are desired at non-key stops.</p> <p>It is preferred to have large signs at CLA building, University Village, New Parking Structure, and Library.</p>

Scenario	Operational Characteristics	Score (1-10)	Comments
4.1.2 CPP Student in the Library Needing to Catch a Bus	1. Real time schedule presented on Web with updates where buses are	10	<u>Hit rates are concerned because of commuting riders.</u>
	2. Update on Web with rider information on bus (full or not)	10	This scenario is about a large message board at library and a display of bus information on web. Real-time schedule updating on the Web is important.
	3. Update on Web with out of service indication (due to failure)	10	<u>Updates at stops are more important than those on the Web.</u> Users would like to see, on web site and signs, the display of the following information:
	4. Update on Web with information of breaks and lunches	10	<ul style="list-style-type: none"> ▪ <u>if bus is full</u> ▪ <u>out-of-service</u> ▪ <u>if bus is not running (broken)</u> ▪ <u>if driver is on-break / on-lunch</u> ▪ <u>other status notices</u>

Scenario	Operational Characteristics	Score (1-10)	Comments
4.1.3 CPP Student with a Cell Phone Needing to Catch a Bus	1. Voicemail system	8	<p>Voicemail system seems more relevant than real-time web site, because everyone has a cell phone.</p> <p>Concerns are on how to implement the voicemail system. The Advisory Member (AP) members suggest a phone tree system and a text-messaging system.</p> <p>Voicemail message searching time should be short.</p> <p>Concerns are also on how to identify stop number. Stop number should be published via different media. Stop number should be published and be listed on stop signs.</p> <p>Possibly some way to search for stops (alphabetically, etc.) is needed.</p> <p>The idea of pushing data to phones (text messaging) is suggested.</p> <p>The AP members don't like the quick-reference cards since they can be easily lost or misplaced.</p>

Scenario	Operational Characteristics	Score (1-10)	Comments
<p>CPP Student with a Web-Enabled Cell Phone Needing to Catch a Bus</p>	<p>1. Web-enabled phone or PDA feature</p>	<p>6</p>	<p>The AP members ranked the importance of using Web-enabled cell phone to access bus arrival information same as that of using the Web (see Scenario 4.1.2)</p> <p>The AP members liked the idea of pushing data to phones (or emails).</p>
<p>Cal Poly or Laidlaw Driver Starting Day's Work</p>	<p>1. Sign on by route</p> <p>2. Enter employee ID #, MDT validates # entered (drop-down ID list not desirable)</p> <p>3. MDT receive odometer reading at beginning and end of deadheads, beginning and end of service (work), and at fuel stops</p> <p>4. MDT displays countdown until departure for all stops based on actual arrival time and scheduled departure time.</p>	<p>10</p> <p>10</p> <p>10</p> <p>10</p>	<p>The AP members liked the suggested "Sign on by Route" login process.</p> <p>Drivers enter employee ID directly rather than select their ID from a list. MDT validates employee ID number.</p> <p>Odometer should be captured at: Beginning of deadhead End of deadhead Fuel stops</p> <p>MDT count-downs should be based upon: Actual arrivals Scheduled departures</p> <p>Some stops may not have countdown displayed due to no actual layover occurring. MDT will always indicate that it is time to depart as necessary.</p>

Scenario	Operational Characteristics	Score (1-10)	Comments
4.2.2 Cal Poly or Laidlaw Driver's Changing Shift	<ol style="list-style-type: none"> 1. Driver ID entered manually instead of via drop-down list 2. MDT differentiates between shift end and driver shift change 3. Shift change data transmitted to central site for archiving and later reporting 4. MDT allows route-change by drivers. All shift login & logout information (route/ time, date, etc.) to be collected as Operational Scenario 4.2.1. 	<p>10</p> <p>10</p> <p>10</p> <p>10</p>	<p>See Operational Scenario 4.2.1.</p> <p>Route must be entered or validated/confirmed at time of shift change. Bus may change routes at shift change. Confirmation of route selection is needed.</p> <p>Login information including driver ID#, driver ID carries over from before route change.</p> <p>Route-change function is needed. Buses may switch routes to take over of broken-down buses.</p> <p>Discussion of relief is as follows:</p> <ul style="list-style-type: none"> ▪ <u>Relief point(s) may not work with staggered routes.</u> ▪ Relief driver should enter ID number and validate rather than select name from a list. ▪ Relaying of shift change information from MDT to Central Site is important.

Scenario	Operational Characteristics	Score (1-10)	Comments
4.2.3 Cal Poly or Laidlaw Driver Logout	<ol style="list-style-type: none"> 1. MDT prompts driver for odometer reading at end of route/service. 2. MDT will also prompt for odometer data at end of logout 	<p>10</p> <p>10</p>	<p>It seems that it would be good for MDT to have simple buttons/keys for predetermined events such as start of deadhead, end of deadhead, beginning of service, end of service, shift change, route change, fuel stop, start and end of break, etc. MDT would prompt driver for the information required for each of these events.</p> <p>All odometer reading events should be date and time stamped, and transmitted to dispatch at some point.</p> <p>Mileage should be collected at both log-in & log-out. Mileage should be collected for both end-of-deadhead and end-of-service miles. Collection of data/time/location stamps upon collection of mileage marks is useful.</p> <p>Bus yard / fuel stops / etc should be stop-points in the system.</p>

Scenario	Operational Characteristics	Score (1-10)	Comments
4.2.4 Cal Poly or Laidlaw Driver on Route and Picking up Passengers	<ol style="list-style-type: none"> 1. Automatic departure countdown presented to driver all stops 2. MDT receives button press for each boarding passenger . 3. MDT associates boarding count with data for that stop. 	<p>10</p> <p>10</p>	<p>Existing procedure is informal counts and is marked on trip-sheet.</p> <p>The AP members feel little interests in using card-swipe as a way to count because of the following concerns:</p> <ul style="list-style-type: none"> ▪ Students may not have card with them. ▪ What about visitors to the campus? <p>APC may be an option.</p> <p>The AP members suggested a "Bus is Full" option (button/function on the bus) if APC is not considered.</p> <p>Passenger counter function (one press per each person boarding) is preferable to entering number of boarders at the end of boarding.</p>

Scenario	Operational Characteristics	Score (1-10)	Comments
4.2.5 Cal Poly or Laidlaw Driver on Route & Picking up Riders with Automatic Passenger Counter	1. APCs on buses	6	<p>The AP members expressed concerns on APC accuracy issues.</p> <p>APC is expensive. Can the test deployment grant cover the APC costs?</p> <p>If APC is planned for use in the system, how many buses should have APC installed?</p> <p>The AP members would like to have APC capability to install in the future.</p>

Scenario	Operational Characteristics	Score (1-10)	Comments
4.2.6 Dangerous Situation on Bus	1. Both Cal Poly and Laidlaw dispatch consoles should have acknowledgement responsibility on alarm.	10	<p>Laidlaw and CPP have dispatch consoles. Terminals at both ends should have to acknowledge emergency.</p> <p>SLO Transit procedures are preferred. However the length of procedures / requirements on dispatch is concerned.</p> <p>The AP members feel Cal Poly Pomona PTS should develop an emergency response protocol and procedures. The CP SLO's procedures should be included for reference.</p> <p>Currently CPP and Laidlaw have separate radio systems. It is preferred to consolidate voice communications for both CPP and Laidlaw.</p> <p>Multiple emergency notification vectors are needed.</p> <p>There may be alternative security / safety funding available to assist this effort.</p> <p>The system may need audio / visual / cellular options for notification of emergencies.</p>

Scenario	Operational Characteristics	Score (1-10)	Comments
4.2.7 Going on Break	<ol style="list-style-type: none"> 1. MDT prompts driver for odometer reading at beginning and end of break. 2. MDT will also prompt for odometer data at end of logout for break 	<p style="text-align: center;">10</p> <p style="text-align: center;">10</p>	See Operational Scenario 4.2.3 (Driver Log-out)
4.2.8 Fueling	<ol style="list-style-type: none"> 1. MDT prompts driver for odometer reading at the time of fueling. 2. MDT will also prompt for odometer data at the end of logout for fueling. 	<p style="text-align: center;">10</p> <p style="text-align: center;">10</p>	See Operational Scenario 4.2.3 (Driver Log-out)

Scenario	Operational Characteristics	Score (1-10)	Comments
<p><u>4.3.1 Dispatchers at Work</u></p>	<ol style="list-style-type: none"> 1. EDAPTS dispatch console at CPP and Laidlaw 2. Fleet Status Table 3. Bronco Express system map 4. Rider load information 	<p>10</p> <p>10</p> <p>8</p> <p>10</p>	<p>The Advisory Panel members are concerned with the level of interaction with the console. A minimal level of interaction is desired.</p> <p>Events displayed on the consoles would likely be driven by events from the buses. Console is generally passive, except where emergency management is desired.</p> <p>A console in Police Department (PD) to monitor emergencies is suggested.</p> <p>Network/Internet access is required for console to access server (Laidlaw, PD, etc.)</p> <p>Loading column in Fleet status table could be with information "Bus not full" or "Bus is Full". A function on the bus is desired to clear "Bus is Full."</p> <p>It would be helpful to have different colors / categories /etc for different events (scheduled breaks vs. non-scheduled breaks, etc)</p> <p>Updating intervals of console should be similar to those for updates locations of buses.</p>

Scenario	Operational Characteristics	Score (1-10)	Comments
4.3.2 Dispatchers know where vehicles are	System Map Fleet Status Table	6 10	<p>Map would be nice to have, but may not be necessary.</p> <p>Map-based display may be important / critical for emergency functions.</p> <p>Log-on/off in this scenario is same as log-on/off and shift change previously discussed in Scenario 4.2.2.</p>
4.3.3 Dispatch Bus with Serious Mechanical Failure	System Map Fleet Status Table	6 10	<p>Map-based GUI may be useful to this function, but is not essential since drivers can communicate with dispatch.</p> <p>Two-phased implantation approach is desired. Map initially used in dispatch may be replaced by real time map with fully-integrated GUI.</p> <p>Dispatch needs to be able to remove "Out of Service" conditions from the console - a dead bus may not be able to clear the message.</p> <p>Driver will make the call, but dispatcher will type in the failure. Whoever is pulling the bus should log.</p> <p>Need to be able to differentiate between Laidlaw and CPP buses. In the current system, X-1 is a State driver, X-2 is a Laidlaw driver. If schedule is moved to a fixed schedule, it will likely need a different 'numbering' scheme.</p>

Scenario	Operational Characteristics	Score (1-10)	Comments
4.4.1 <u>Use Passenger loading reports to optimize vehicle size</u>	Ride Report	6	It depends upon APC functionality.
4.4.2 <u>Use Schedule Adherence reports to adjust schedule</u>	Schedule Adjustment	7	It is desired that the EDAPTS system can analyze schedule adherence and recommend schedule modifications
4.5.1 <u>Provide monthly reports to CPP</u>	Ride Report Monthly Report	6 10	It requires collection of rider loading data. It may want APC to assist this.
4.6.1 <u>Schedule and Route Updates</u>	Schedule and route updates	10	This is an essential feature. MDTs and Signs have to be updated with new schedule - automatic updates.
4.6.2 <u>Addition of New Stops on a Route</u>	Adding stops to a route	10	This is an essential feature. It should consider locations for possible future stops.

Scenario	Operational Characteristics	Score (1-10)	Comments
4.6.3 <u>On-Board Hardware Maintenance</u>	<p>Spare hardware</p> <p>On-site trouble shooting</p> <p>Component replacement</p>	<p>10</p> <p>10</p> <p>10</p>	<p>Make sure there are spare components.</p> <p>Modularity of components is important to facilitate replacement.</p> <p>Laidlaw / CPP needs to discuss the following maintenance issues</p> <ul style="list-style-type: none"> ▪ Who is responsible for replacing components on different buses? ▪ Are there personnel available to swap out components? ▪ Who is allowed to install / replace components on a Laidlaw / CPP bus? ▪ Who maintains / provides the spares for replacement? ▪ Who is responsible for equipment / software / project end-of-life? ▪ Would hot-swaps during the day be important, or resolve after-hours? ▪ Do we need training from the Commercial Provider to allow replacements?

Scenario	Operational Characteristics	Score (1-10)	Comments
4.6.4 <u>Dispatch Console Maintenance</u>	Console Maintenance	10	Make sure there are spare components. Make sure there are personnel available to swap out components. Laidlaw / CPP needs to discuss maintenance issues.
4.6.5 <u>Vehicle-to-Central Dispatch Communications Link Failure</u>	Vehicle to Central Dispatch Maintenance	10	Laidlaw / CPP needs to discuss maintenance issues.
4.6.6 <u>On-Board Equipment Failure</u>	On-Board Equipment Maintenance	10	Laidlaw / CPP needs to discuss maintenance issues.
4.6.7 <u>Transit Sign Failure</u>	Transit sign Repair	10	Laidlaw / CPP needs to discuss maintenance issues.
4.6.8 <u>Computer Console or Server Failure</u>	EDAPTS Server Maintenance	10	Laidlaw / CPP needs to discuss maintenance issues.

APPENDIX A
EXISTING OPERATIONS

This appendix describes how the existing Bronco Express system currently operates for providing shuttle services to students, faculty and staff of Cal Poly Pomona. It summarizes the operational procedures obtained from the one-day workshop on July 20, 2006.

This appendix is organized by the five following categories:

- 1) Bronco Express System from Dispatcher's Perspective
- 2) Bronco Express System from Driver's Perspective
- 3) Bronco Express System from Passenger's Perspective
- 4) Bronco Express System from PTS Staff's Perspectives
- 5) Bronco Express System from Maintenance Perspectives

1. Dispatcher's Perspective

Cal Poly Pomona buses have no dedicated dispatcher for bus operations. Any dispatch functions occur through Cal Poly Pomona Police Department for the two state-owned vehicles (or State buses) and through Laidlaw dispatcher for all other vehicles (Laidlaw buses). In other words, the Police Dispatcher (or the State dispatcher) has two types of jobs: 1) dispatch police and parking vehicles and 2) dispatch State vehicles. The State dispatcher has no direct contact with Laidlaw Transportation under normal circumstances. Any contacts to Laidlaw Transportation Company are made through the Parking & Transportation System (PTS) Bus Operations Program Manager.

Duties performed by the Cal Poly Police Department dispatcher are:

a) Receive notification of faulty buses

- 1) The Police dispatcher is notified by the State driver when the State bus has a safety or operational issue. Note that there is only one State driver in PTS. The driver logs this issue in the vehicle inspection report book (Vehicle Log), which is submitted to PTS once a month.
- 2) The dispatcher forwards the concern to the PTS Bus Operations Program Manager

b) Receive calls from Laidlaw dispatch regarding problems On Route

- 1) Both the State driver (via radio) and the Laidlaw dispatcher call the State dispatcher on the telephone informing the State dispatcher that the State bus or a Laidlaw bus has a problem on route. The State driver can talk to the State dispatcher directly. The Laidlaw driver, when having a problem on route, needs to inform the Laidlaw dispatcher first. No direct communication exists between the Laidlaw drivers and the

State Dispatcher.

- 2) State dispatcher takes appropriate action.

c) Receive sick calls from State driver

- 1) Police or State dispatcher receives a call from the State driver indicating he is sick and won't be able to come to work.
- 3) Police or State dispatcher calls PTS Bus Operations Program Manager for assistance from Laidlaw. The Program Manager then calls the Laidlaw dispatcher for a fill-in route. Laidlaw will inform the Manager when the bus will be on line.

Note for EDAPTS System Designer: Arrangements may have to be made to have EDAPTS equipment on backup Laidlaw buses.

2. DRIVER'S PERSPECTIVE

There are two types of drivers working for Bronco Express: Cal Poly Pomona State driver and Laidlaw drivers. Cal Poly Pomona has two State buses, while Laidlaw has six buses. All eight buses are painted with the "Bronco Express" scheme. Laidlaw has several reserved buses available but they are not painted with the "Bronco Express" scheme.

Duties performed by the State driver and Laidlaw drivers are as follows:

a) Route assignment

- 1) Route A is served by both the State driver and the Laidlaw drivers.
- 2) Routes B and C are served by the Laidlaw drivers.
- 3) The Laidlaw driver assigned for Route A starts his service at 7:20 AM at University Village. The State driver starts his service at 7:30 AM at the bus stop close to PTS. The Laidlaw drivers assigned for Routes B and C start their service at the predefined stops at 7:30 AM.

b) Check safety and operational features and record the checking results in vehicle log

- 1) Both the State driver and the Laidlaw drivers check safety and operational features before they begin service. They complete all required information into the Vehicle Log daily. This log is submitted to PTS monthly.
- 2) The State driver may only drive the State bus and the Laidlaw drivers may only drive Laidlaw buses. Neither drives buses from the other entity.

- 3) If a State driver discovers safety and/or operational concerns, he notifies the Cal Poly Pomona Police Dispatcher. The Dispatcher will further inform the concerns to the Bronco Express Bus Operations Program Manager (or Coordinator). Upon discovering a problem, the State driver will either drive the bus to the Cal Poly auto shop or have mechanics come to work on the bus. If both State buses are inoperable, then the State driver will contact the coordinator and request fill-in service from Laidlaw.
- 4) If a Laidlaw driver finds safety or operational problems from his assigned Laidlaw bus, he reports the problems to his Laidlaw dispatcher and switches another Laidlaw bus and begins his service at Cal Poly Pomona campus.

c) Conduct rider counts

- 1) Both State and Laidlaw drivers are required to press the rider counter buttons when riders board their bus.
- 2) Rider counts are recorded by route and by time. Drivers are required to fill rider counts into the Ridership Log and turn the raw rider count data to the PTS on a daily basis. They must also turn in a monthly report of rider counts at the end of each month.

d) Sick leave issue

- 1) When the State driver calls the Police Dispatcher for a sick leave, the Police Dispatcher forwards his request to the Bronco Express Coordinator (or Program Manager). The Bronco Express Coordinator will ask the Laidlaw for fill-in. The extra Laidlaw bus driver (in addition to the five Laidlaw bus drivers) will drive a Laidlaw bus to perform this service. The extra service will be paid by the Cal Poly Pomona's PTS.
- 2) Both State and Laidlaw drivers do not provide any services for special events. Special events are covered under a separate arrangement between Cal Poly and Laidlaw. PTS is not involved in this service.

e) Driver coordination

- 1) The State driver does not communicate with Laidlaw drivers. He ideally maintains a half-cycle distance between him and other buses to keep buses from bunching up. All drivers work towards this goal.
- 2) Neither State nor Laidlaw drivers may overtake other buses.

f) When the bus is full or at break times

- 1) Both State and Laidlaw drivers must stop additional riders from boarding when the bus becomes full.
- 2) The State and Laidlaw drivers have their breaks at predefined stops at predefined times. The break time is normally 10-15 minutes. The selection of the stops for breaks is close to restrooms.
- 3) Buses are scheduled out of service for driver breaks at the times listed in the PTS Bronco Express System Map.

3. PASSENGER'S PERSPECTIVE

Bronco Express system provides shuttle services to passengers including students, faculty and staff of Cal Poly Pomona. The existing services viewed by passengers are

a) Planning to Catch the Bus

It is assumed that most riders wish to catch a bus from the dormitories, classrooms, offices, parking structures, and parking lots around the campus.

- 1) Students, faculty, staff, and visitors have no way to make catching the bus easier. The only method possible is to stand and wait for a bus.
- 2) Riders would like to get information about where the buses are and when the bus will come at a certain stop before they plan to catch a bus at a stop.
- 3) Web services, cell phone-based voice announcement, or other ways are needed.

b) Catching the Bus

It is assumed that riders are already at bus stops and are waiting for coming buses.

- 1) Signs that indicate predicted arrival time for buses at stops are desired.
- 2) Kiosks that show the map with the current locations of buses would be useful also.
- 3) Kiosks that have voice functions are preferred. Riders can push a sequence of buttons and know the bus information through voice output.

Known issues and problems related to the existing service include

- 1) Words "Route X" ("X" being either A, B, or C) is painted on State and Laidlaw buses. Riders do not pay attention to these Words. The AP member suggested that dynamic "Origin-Destination" signs could supplement the "Route X" signs. The signs

could be “University Village – Kellogg Drive – CLA” and “CLA - University Dr. – University Village.”

- 2) Most riders seem to have little knowledge of routes and will board just about any bus that arrives. Some riders are more discriminating when selecting a bus.
- 3) New students will require training on bus system operations. Maybe the orientation program could help.
- 4) Riders need to know when bus is coming and when bus drivers are on break. The type of information should be provided to riders. The need to know the current location of buses is the high-priority needs.
- 5) When bus is delayed or full, notification to riders would be nice.
- 6) Emergency evacuation plan should be provided.

4. PTS STAFF PERSPECTIVES

The Cal Poly PTS director assumes the role of transit coordination and dispatch. The Bronco Express Bus Operation Project Manager generally performs this task in the daytime, the evening parking supervisor at night, and the senior parking officer on Monday nights.

PTS does not operate with a fixed schedule, but on fixed routes. It seems that the buses are operated on a quasi-fixed schedule. Drivers are scheduled at least to have breaks at predefined stops at predefined times. Without a quasi-fixed schedule, it is very difficult for the drivers to have breaks.

Route changes are currently based on ridership, complaints with surveys, and construction activities. It is also desirable to give drivers better information regarding safety and on-time performance. PTS staff put out a “We Care” survey and only six were received completed.

The duties and daily work of the PTS staff include:

A) Coordinate with Laidlaw

The PTS staff generally performs all coordination with Laidlaw.

b) Bus driver sick or both State buses inoperable

- 1) PTS requests a replacement bus and driver from Laidlaw.
- 2) Laidlaw indicates when a bus and driver will be available.
- 3) PTS director instructs parking officers to annotate marking board on bus signs to indicate service on the specified route will be unavailable for a given amount of time.

5. MAINTENANCE PERSEPECTIVES

When a State bus is broken, it will be sent to the auto shop for repair. When a Laidlaw bus is broken, a reserved bus for service will replace it. The PTS does not have any maintenance responsibilities of Laidlaw buses.

The Laidlaw buses fuel at the State auto shop using a State fuel card. Laidlaw reimburses Cal Poly Pomona the fuel expenses each month.



EDAPTS
Smart Transit System



RFP 07-014
Exhibit D

Cal Poly Pomona EDAPTS Test Deployment

Description of Bus Stops for Test Deployment

Prepared for
California Partners for Advanced Transit and Highways
California Department of Transportation

Prepared by

Xudong Jia, Ph.D., P.E
California State Polytechnic University, Pomona

And

Jeff Gerfen
California Polytechnic State University, San Luis Obispo

Under PATH Contract TO 6403

June 8, 2007

The Bronco Express EDAPTS system is planned to provide and install Dynamic Roadside Information Displays at four bus stops. The system will be expanded later to include displays at other bus stops on Routes A, B, and C.

The descriptions of the proposed bus stops are as follows:

1. Bus Stop at Building 98

The bus stop is located on Olive Lane at Building 98, Classroom/Laboratory/Administration (CLA) Building. Figure D.1 illustrates the detailed location of the bus stop.



Figure D.1 Location of the CLA Bus Stop

The location has the following attributes pertaining to the test deployment:

Power Supply:	Power is available a few feet away from the bus stop. The power outlet is within the stairway tower.
WiFi Signal Strength:	The University-wide WiFi signal can be detected at the bus stop. The signal strength is measured by a Laptop computer with two “bars”, which means that the bus stop can receive minimum-strength, working signals for WiFi services.
Bus Stop Post Foundation:	Bus stop foundation is solid for small signs. However, it cannot be strong enough to support a large format sign.
Display Installation:	The display is preferably installed on the front wall of the stairway tower.
Service Routes:	Routes A & B

2. Bus Stop at Parking Structure

The existing bus stop is located on Magnolia Dr., 50 ft away from the pedestrian exit of the parking structure. Figure D.2 illustrates the detailed location of the bus stop.

The existing bus stop has the following attributes pertaining to the test deployment:

Power Supply:	Power is not available within the vicinity of the bus stop. If power is needed for the small format sign, a field work is needed to provide the power from the Parking Structure to the bus stop. Battery-based small format sign is preferred.
WiFi Signal Strength:	The University-wide WiFi signal can be detected at the bus stop. The signal strength is measured with one “bar”, which means that the bus stop cannot receive reliable signals for WiFi services.
Bus Stop Post Foundation:	Bus stop foundation is not solid for small signs. It cannot be strong enough to support a small format sign. The foundation should be reconstructed for the test deployment.
Display Installation:	The display shall be installed on the bus post.

Served Route: Route B



Figure D.2 Location of the Bus Stop at the Parking Structure

The symbol ☆ as shown in Figure D.2 indicates the proposed bus stop for the test deployment. The new location will provide a larger place for passengers waiting for Bronco Express buses. Also the WiFi signals are stronger at the proposed location.

The proposed location has the following attributes for the EDAPTS project:

Power Supply: Power is not available within the vicinity of the bus stop. If power is needed for the small format sign, a field work is needed to provide the power from the Parking Structure to the bus stop.

Battery-based small format sign is preferred.

WiFi Signal
Strength:

The University-wide WiFi signal can be detected at the bus stop. The signal strength is measured with two “bars”, which means that the bus stop cannot receive minimal-strength, working signals for WiFi services.

Bus Stop Post
Foundation:

Bus stop foundation is not solid for small signs. It cannot be strong enough to support a small format sign. The foundation should be reconstructed for the test deployment.

Display Installation: The display shall be installed on the bus post.

Served Route: Route B

3. Bus Stop at Building 94

The bus stop is located on University Drive, a few feet away from Building 94. Figure D.3 illustrates the detailed location of the bus stop.



Figure D.3 Location of the Bus Stop at Building 94

The bus stop has the following attributes pertaining to the test deployment:

- Power Supply:** Power is not available within the vicinity of the bus stop. If power is needed for the small format sign, a field work is needed to provide the power from Building 94 to the bus stop.
- Battery-based small format sign is preferred.
- WiFi Signal Strength:** The University-wide WiFi signal can be detected at the bus stop. The signal strength is measured with two “bars”, which means that the bus stop cannot receive minimal-strength, working signals for WiFi services.
- Bus Stop Post Foundation:** Bus stop foundation is not solid for small signs. It cannot be strong enough to support a small format sign. The foundation should be reconstructed for the test deployment.
- Sign Installation:** The small format sign shall be installed on the bus post.
- Served Route:** Routes A and B

4. Bus Stop at University Village

The bus stop is located inside the University Village. It is the end of Route A. Figure D.4 illustrates the detailed location of the bus stop.

The bus stop has the following attributes pertaining to the test deployment:

- Power Supply:** Power is not available within the vicinity of the bus stop. If power is needed for the small format sign, a field work is needed to provide the power from a Village Building to the bus stop.
- Battery-based small format sign is preferred.
- WiFi Signal Strength:** The University-wide WiFi signal cannot detected at the bus stop. If Wifi option is selected for the test deployment project, a wireless access point shall be provided at the bus stop.

Bus Stop Post

Foundation: Bus stop foundation is not solid for small signs. It cannot be strong enough to have a small format sign. The foundation should be reconstructed for the test deployment.

Display Installation: The display shall be installed on the bus post.

Served Route: Route A



Figure D.4 Location of the Bus Stop within the University Village



EDAPTS

Smart Transit System



RFP 07-014
Exhibit E

Cal Poly Pomona EDAPTS Test Deployment

Sample Reports

Prepared for
California Partners for Advanced Transit and Highways
California Department of Transportation

Prepared by
Xudong Jia, Ph.D., P.E
California State Polytechnic University, Pomona

And

Jeff Gerfen
California Polytechnic State University, San Luis Obispo

Under PATH Contract TO 6403

June 8, 2007

Ridership - Overflow Lot

December, 2007

Laidlaw Transit Services, Inc.

December 2007		ROUTE D - BOARDINGS													TOTAL PASS
		7:30 - 8:30	8:30 - 9:30	9:30 - 10:30	10:30 - 11:30	11:30 - 12:30	12:30 - 13:30	13:30 - 14:30	14:30 - 15:30	15:30 - 16:30	16:30 - 17:30	17:30 - 18:30	18:30 - 19:30	22:30 - 23:00	
Sun		-	-	-	-	-	-	-	-	-	-	-	-	-	-
Mon		-	-	-	-	-	-	-	-	-	-	-	-	-	-
Tue		-	-	-	-	-	-	-	-	-	-	-	-	-	-
Wed		-	-	-	-	-	-	-	-	-	-	-	-	-	-
Thu		-	-	-	-	-	-	-	-	-	-	-	-	-	-
Fri		-	-	-	-	-	-	-	-	-	-	-	-	-	-
Sat	1	-	-	-	-	-	-	-	-	-	-	-	-	-	-
WEEK 1 TOTALS		-	-	-	-	-	-	-	-	-	-	-	-	-	-
Sun	2	-	-	-	-	-	-	-	-	-	-	-	-	-	-
Mon	3	-	-	-	-	-	-	-	-	-	-	-	-	-	-
Tue	4	-	-	-	-	-	-	-	-	-	-	-	-	-	-
Wed	5	-	-	-	-	-	-	-	-	-	-	-	-	-	-
Thu	6	-	-	-	-	-	-	-	-	-	-	-	-	-	-
Fri	7	-	-	-	-	-	-	-	-	-	-	-	-	-	-
Sat	8	-	-	-	-	-	-	-	-	-	-	-	-	-	-
WEEK 2 TOTALS		-	-	-	-	-	-	-	-	-	-	-	-	-	-
Sun	9	-	-	-	-	-	-	-	-	-	-	-	-	-	-
Mon	10	-	-	-	-	-	-	-	-	-	-	-	-	-	-
Tue	11	-	-	-	-	-	-	-	-	-	-	-	-	-	-
Wed	12	-	-	-	-	-	-	-	-	-	-	-	-	-	-
Thu	13	-	-	-	-	-	-	-	-	-	-	-	-	-	-
Fri	14	-	-	-	-	-	-	-	-	-	-	-	-	-	-
Sat	15	-	-	-	-	-	-	-	-	-	-	-	-	-	-
WEEK 3 TOTALS		-	-	-	-	-	-	-	-	-	-	-	-	-	-
Sun	16	-	-	-	-	-	-	-	-	-	-	-	-	-	-
Mon	17	-	-	-	-	-	-	-	-	-	-	-	-	-	-
Tue	18	-	-	-	-	-	-	-	-	-	-	-	-	-	-
Wed	19	-	-	-	-	-	-	-	-	-	-	-	-	-	-
Thu	20	-	-	-	-	-	-	-	-	-	-	-	-	-	-
Fri	21	-	-	-	-	-	-	-	-	-	-	-	-	-	-
Sat	22	-	-	-	-	-	-	-	-	-	-	-	-	-	-
WEEK 4 TOTALS		-	-	-	-	-	-	-	-	-	-	-	-	-	-
Sun	23	-	-	-	-	-	-	-	-	-	-	-	-	-	-
Mon	24	-	-	-	-	-	-	-	-	-	-	-	-	-	-
Tue	25	-	-	-	-	-	-	-	-	-	-	-	-	-	-
Wed	26	-	-	-	-	-	-	-	-	-	-	-	-	-	-
Thu	27	-	-	-	-	-	-	-	-	-	-	-	-	-	-
Fri	28	-	-	-	-	-	-	-	-	-	-	-	-	-	-
Sat	29	-	-	-	-	-	-	-	-	-	-	-	-	-	-
WEEK 5 TOTALS		-	-	-	-	-	-	-	-	-	-	-	-	-	-
Sun	30	-	-	-	-	-	-	-	-	-	-	-	-	-	-
Mon	31	-	-	-	-	-	-	-	-	-	-	-	-	-	-
Tue		-	-	-	-	-	-	-	-	-	-	-	-	-	-
Wed		-	-	-	-	-	-	-	-	-	-	-	-	-	-
Thu		-	-	-	-	-	-	-	-	-	-	-	-	-	-
Fri		-	-	-	-	-	-	-	-	-	-	-	-	-	-
Sat		-	-	-	-	-	-	-	-	-	-	-	-	-	-
WEEK 6 TOTALS		-	-	-	-	-	-	-	-	-	-	-	-	-	-
Totals		-	-	-	-	-	-	-	-	-	-	-	-	-	-
Total for Shuttle 1															

			Week 1	Week 2	Week 3	Week 4	Week 5	Week 6
3,618	ROUTE A		0	3,618	0	0	0	0
106	2.9%	7:30 - 8:30	0	106	0	0	0	0
317	8.8%	8:30 - 9:30	0	317	0	0	0	0
172	4.8%	9:30 - 10:30	0	172	0	0	0	0
384	10.6%	10:30 - 11:30	0	384	0	0	0	0
251	6.9%	11:30 - 12:30	0	251	0	0	0	0
179	4.9%	12:30 - 13:30	0	179	0	0	0	0
253	7.0%	13:30 - 14:30	0	253	0	0	0	0
368	10.2%	14:30 - 15:30	0	368	0	0	0	0
391	10.8%	15:30 - 16:30	0	391	0	0	0	0
326	9.0%	16:30 - 17:30	0	326	0	0	0	0
231	6.4%	17:30 - 18:30	0	231	0	0	0	0
189	5.2%	18:30 - 19:30	0	189	0	0	0	0
154	4.3%	19:30 - 20:30	0	154	0	0	0	0
138	3.8%	20:30 - 21:30	0	138	0	0	0	0
96	2.7%	21:30 - 22:30	0	96	0	0	0	0
63	1.7%	22:30 - 23:00	0	63	0	0	0	0
1,094	ROUTE B		0	1,094	0	0	0	0
67	6.1%	7:30 - 8:30	0	67	0	0	0	0
119	10.9%	8:30 - 9:30	0	119	0	0	0	0
82	7.5%	9:30 - 10:30	0	82	0	0	0	0
135	12.3%	10:30 - 11:30	0	135	0	0	0	0
97	8.9%	11:30 - 12:30	0	97	0	0	0	0
106	9.7%	12:30 - 13:30	0	106	0	0	0	0
76	6.9%	13:30 - 14:30	0	76	0	0	0	0
91	8.3%	14:30 - 15:30	0	91	0	0	0	0
83	7.6%	15:30 - 16:30	0	83	0	0	0	0
68	6.2%	16:30 - 17:30	0	68	0	0	0	0
68	6.2%	17:30 - 18:30	0	68	0	0	0	0
51	4.7%	18:30 - 19:30	0	51	0	0	0	0
51	4.7%	19:30 - 20:30	0	51	0	0	0	0
3,627	ROUTE C		0	3,627	0	0	0	0
262	7.2%	7:30 - 8:30	0	262	0	0	0	0
380	10.5%	8:30 - 9:30	0	380	0	0	0	0
332	9.2%	9:30 - 10:30	0	332	0	0	0	0
362	10.0%	10:30 - 11:30	0	362	0	0	0	0
360	9.9%	11:30 - 12:30	0	360	0	0	0	0
374	10.3%	12:30 - 13:30	0	374	0	0	0	0
265	7.3%	13:30 - 14:30	0	265	0	0	0	0
383	10.6%	14:30 - 15:30	0	383	0	0	0	0
257	7.1%	15:30 - 16:30	0	257	0	0	0	0
240	6.6%	16:30 - 17:30	0	240	0	0	0	0
173	4.8%	17:30 - 18:30	0	173	0	0	0	0
146	4.0%	18:30 - 19:30	0	146	0	0	0	0
93	2.6%	19:30 - 20:30	0	93	0	0	0	0
0	OVERFLOW LOT		0	0	0	0	0	0
-	#DIV/0!	7:30 - 8:30	0	0	0	0	0	0
-	#DIV/0!	8:30 - 9:30	0	0	0	0	0	0
-	#DIV/0!	9:30 - 10:30	0	0	0	0	0	0
-	#DIV/0!	10:30 - 11:30	0	0	0	0	0	0
-	#DIV/0!	11:30 - 12:30	0	0	0	0	0	0
-	#DIV/0!	12:30 - 13:30	0	0	0	0	0	0
-	#DIV/0!	13:30 - 14:30	0	0	0	0	0	0
-	#DIV/0!	14:30 - 15:30	0	0	0	0	0	0
-	#DIV/0!	15:30 - 16:30	0	0	0	0	0	0
-	#DIV/0!	16:30 - 17:30	0	0	0	0	0	0
-	#DIV/0!	17:30 - 18:30	0	0	0	0	0	0
-	#DIV/0!	18:30 - 19:30	0	0	0	0	0	0
-	#DIV/0!	19:30 - 20:30	0	0	0	0	0	0

Billing Detail Recap

December, 2007

Laidlaw Transit Services, Inc.

		ROUTE A				ROUTE B							
December, 2007		Total	HOURS Billable	D/H	Total	MILES Billable	D/H	Total	HOURS Billable	D/H	Total	MILES Billable	D/H
Sun													
Mon													
Tue													
Wed													
Thu													
Fri													
Sat	1												
WEEK 1 TOTALS													
Sun	2												
Mon	3	25.75	25.75		278.0	278.0		26.00	26.00		246.0	246.0	
Tue	4	25.58	25.58		279.0	279.0		26.00	26.00		241.0	241.0	
Wed	5	25.67	25.67		275.0	275.0		26.00	26.00		248.0	248.0	
Thu	6	25.50	25.50		275.0	275.0		26.00	26.00		240.0	240.0	
Fri	7	25.50	25.50		311.0	311.0		14.00	14.00		141.0	141.0	
Sat	8												
WEEK 2 TOTALS		128.00	128.00		1,418.0	1,418.0		118.00	118.00		1,116.0	1,116.0	
Sun	9												
Mon	10												
Tue	11												
Wed	12												
Thu	13												
Fri	14												
Sat	15												
WEEK 3 TOTALS													
Sun	16												
Mon	17												
Tue	18												
Wed	19												
Thu	20												
Fri	21												
Sat	22												
WEEK 4 TOTALS													
Sun	23												
Mon	24												
Tue	25												
Wed	26												
Thu	27												
Fri	28												
Sat	29												
WEEK 5 TOTALS													
Sun	30												
Mon	31												
Tue													
Wed													
Thu													
Fri													
Sat													
WEEK 6 TOTALS													
Totals		128.00	128.00		1,418.0	1,418.0		118.00	118.00		1,116.0	1,116.0	

Shuttle Billing Detail Recap

December, 2007

Laidlaw Transit Services, Inc.

December, 2007		ROUTE C						OVERFLOW LOT					
		Total	HOURS Billable	D/H	Total	MILES Billable	D/H	Total	HOURS Billable	D/H	Total	MILES Billable	D/H
Sun													
Mon													
Tue													
Wed													
Thu													
Fri													
Sat	1												
WEEK 1 TOTALS													
Sun	2												
Mon	3	26.00	26.00		281.0	281.0							
Tue	4	26.00	26.00		280.0	280.0							
Wed	5	26.00	26.00		292.0	292.0							
Thu	6	26.00	26.00		263.0	263.0							
Fri	7	14.00	14.00		141.0	141.0							
Sat	8												
WEEK 2 TOTALS		118.00	118.00		1,257.0	1,257.0							
Sun	9												
Mon	10												
Tue	11												
Wed	12												
Thu	13												
Fri	14												
Sat	15												
WEEK 3 TOTALS													
Sun	16												
Mon	17												
Tue	18												
Wed	19												
Thu	20												
Fri	21												
Sat	22												
WEEK 4 TOTALS													
Sun	23												
Mon	24												
Tue	25												
Wed	26												
Thu	27												
Fri	28												
Sat	29												
WEEK 5 TOTALS													
Sun	30												
Mon	31												
Tue													
Wed													
Thu													
Fri													
Sat													
WEEK 6 TOTALS													
Totals		118.00	118.00		1,257.0	1,257.0							



EDAPTS

Smart Transit System



RFP 07-014
Exhibit F

Cal Poly Pomona EDAPTS Test Deployment

Descriptions of WiFi Services at Cal Poly Pomona

Prepared for
California Partners for Advanced Transit and Highways
California Department of Transportation

Prepared by
Xudong Jia, Ph.D., P.E
California State Polytechnic University, Pomona

And

Jeff Gerfen
California Polytechnic State University, San Luis Obispo

Under PATH Contract TO 6403

June 8, 2007

The University currently provides free Wi-Fi wireless networking services to students, faculty and staff. The existing wireless coverage area is shown in Figure F-1. Additional information on the WiFi services, their characteristics and availability can be found at <http://www.csupomona.edu/~ehelp/wireless/index.html> .

The Cal Poly Pomona wireless network services use the 802.11b standard to support communications up to 11Mbps of bandwidth per "access point." An access point is a fixed wireless transceiver unit that connects the wireless computers to the wired network. As each access point is a "shared" connection, the bandwidth available is split between the connected wireless client users at that access point.

Consequently, the more people using a single access point at a given time, the less responsive the network will appear to be for each user; even though the total throughput rate is at the specified value for the access point itself.

The University provides two on-campus wireless network access protocols:

- a) CPP – This network requires LEAP security authentication, with a Cal Poly Pomona user name and network password. It provides access to most of the services that are available through the on-campus wired internal network.

- b) GUEST – Individuals who do not have Cal Poly Pomona user names and network passwords can use this network connection. It allows basic web browsing and VPN connections. It does not allow users to send e-mail. Access to the GUEST network is similar to the CPP network sign-in process – users enter “GUEST” as the network name, it does not require a password.

If the University Wi-Fi services are selected as the option for the wireless communications for roadside display signs, the Contractor needs to work with the University to identify and install access points close to the four proposed sites as described in Exhibit D.

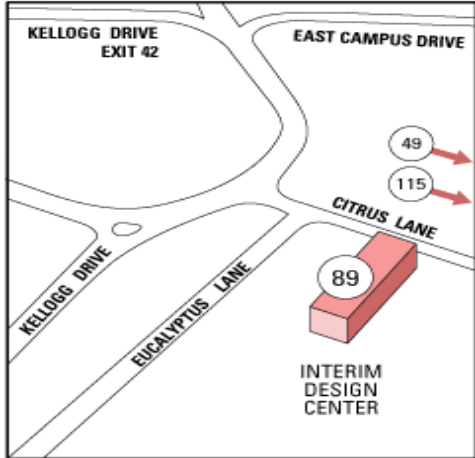
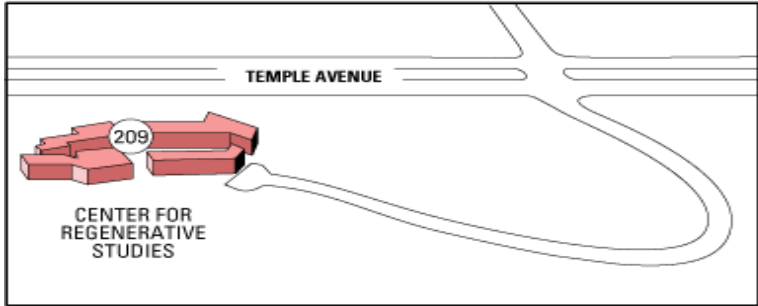
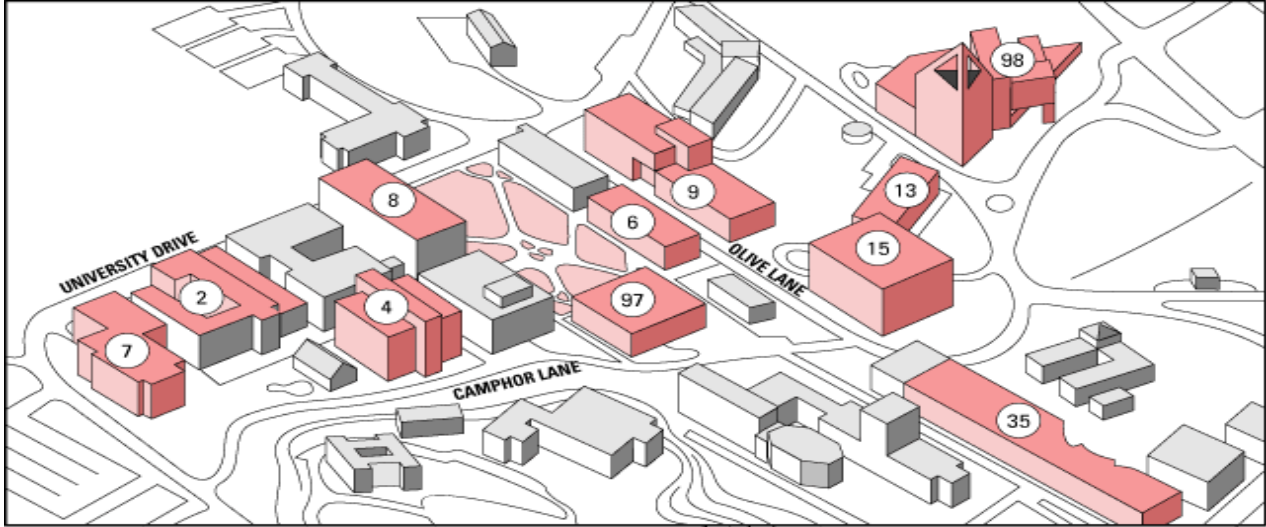

Figure F-1 WiFi Service Area of Cal Poly Pomona

California State Polytechnic University, Pomona

RFP# 07-014}
Bronco Express EDAPTS
(Efficient Deployment of Advanced Public Transportation System)

**Conflict of Interest
And
Confidentiality Statement**

I certify that I have no personal or financial interest and no present or past employment activity which would be incompatible with my participation in this solicitation process and that I am fully able to give full, fair and impartial consideration to all proposals/bids as an appointee to the related evaluation team.

I fully understand and agree to immediately disqualify myself as soon as I am aware of a conflict of interest that may compromise my fair and impartial consideration of the proposals/bids.

I certify that I will hold in the strictest confidence all bids, proposals, correspondence, memoranda, working papers, or any other media which has any bearing on, or discloses any aspect of, any vendor's response or potential response to the RFP.

I fully understand that it is unlawful for a person to utilize any CSU or CSU auxiliary, California Department of Transportation (Caltrans), or Federal Transit Administration (FTA) organization information that is not a matter of public record, for personal pecuniary gain.

I fully understand that any violation of the above is a basis for disciplinary action, including dismissal.

I am aware that the following firms have submitted or may submit proposals:

{List firms}

Date: _____ Signed: _____

Name: _____

Title: _____

Organization: _____

Questions to Syncomatics on EDAPTS Proposal

(Some questions may be duplicated)

1. Can the real-time data or data in a pre-processed (low-latency) data stream be made available to Bronco Express in a format compatible with the EDAPTS Data Standard? If not, can it be made available in another format? We would like to consider importing the data into the existing EDAPTS Dispatch Software to facilitate schedule adherence data retention, route planning, etc by Bronco Express administration. We note that your proposal includes some functionality with regards to route performance and would like to see a demonstration of this capability.
2. Does the existing system have a Vehicle Emergency Alert capability? If so, how does it function?
3. Can the proposed system provide real-time feedback to the driver via the MDT on schedule adherence status for the bus/vehicle they are driving? If not, can that be provided?
4. How is the AVL data from the bus communicated back to the server? Please provide an explanation of this via a block diagram and/or text description.
5. While we understand that a public telecommunications service provider will be used, we would like to see a representative diagram/explanation of the information flows for all links. Are all communications fees for this service contained within your bid? If not, what is your estimate of additional monthly charges for each of these elements?
6. How is the bus arrival information communicated from the server to the signs? Please provide an explanation of this via a block diagram and/or text description.
7. Is proposed signage (roadside displays) ADA compliant? If not, what aspects do you fail to meet? If not, can you provide full compliance and at what cost?
8. Do you have system reliability statistics that you can share with us (uptime of your system)?
9. Can you please help us understand why the difference in pricing for support of signs that are wired vs wirelessly connected?
10. Are "major" upgrades of equipment and software included in your monthly fees?
11. Can you provide the functionality to implement a fixed timetable-based transit system or does the current system already include this functionality? If not, can it be made available and at what price? Features we are interested in include: the ability to set

up route timetables, to report on schedule adherence to those fixed timetables, and to report back in "real-time" to drivers their performance in adhering to those timetables.

- 12.** If the University decides to add more additional signs (or roadside displays) described in your proposal, do you charge with the same rates as the four signs proposed in your proposal?



Procurement and Support Services
Administrative Affairs

Date: March 27, 2008

To: ATTN: Josh Bigelow, CEO
Syncromatics
547 N. Martel Ave.
Los Angeles, CA 90036

From: Debra Garr
Procurement & Support Services
T: (909) 869-3383
F: (909) 869-5475

Subject: RFP No. 07-014 Additional Information Request
Bronco Express EDAPTS
(Efficient Deployment of Advanced Public Transportation System)

Thank you for submitting the above referenced proposal. We have attached a list of questions and clarifications that the evaluation team would like you to answer based on your proposal submitted. We would appreciate a response by 5 PM on April 4, 2008. Thank you for a timely response on these issues.

3801 West Temple Avenue, Pomona, CA 91768

Clarifications and Questions for Syncomatics on EDAPTS Proposal submitted

1. Can the real-time data or data in a pre-processed (low-latency) data stream be made available to Bronco Express in a format compatible with the EDAPTS Data Standard? If not, can it be made available in another format? We would like to consider importing the data into the existing EDAPTS Dispatch Software to facilitate schedule adherence data retention, route planning, etc. by Bronco Express administration. We note that your proposal includes some functionality about route performance and would like to see a demonstration of this capability.
2. Does the existing system have a Vehicle Emergency Alert capability? If so, how does it function?
3. Can the proposed system provide real-time feedback to the driver via the MDT on schedule adherence status for the bus/vehicle they are driving? If not, could that be provided?
4. How is the AVL data from the bus communicated back to the server? Please provide an explanation of this via a block diagram and/or text description.
5. While we understand that a public telecommunications service provider will be used, we would like to see a representative diagram/explanation of the information flows for all links. Are all communications fees for this service contained within your bid? If not, what is your estimate of additional monthly charges for each of these elements?
6. How is the bus arrival information communicated from the server to the signs? Please provide an explanation of this via a block diagram and/or text description.
7. Are the proposed signage/roadside displays ADA (specifically Section 508) compliant? If not, what aspects do you fail to meet? If not, can you provide full compliance and at what cost? **California Government Code Section 11135 requires the California State University (CSU) to comply with Section 508 of the Federal Rehabilitation Act of 1973 and to apply accessibility standards to electronic and information technology (E&IT) products and services that the CSU buys, creates, uses and maintains. The assessment of conformance to the accessibility standards is accomplished via the vendor's conformance documentation and/or vendor submission of Voluntary Product Accessibility Template (VPAT).**
8. Do you have system reliability statistics that you can share with us (uptime of your system)?

9. Could you please help us understand why the difference in pricing for support of signs that are wired verses wirelessly connected?
10. Are "major" upgrades of equipment and software included in your monthly fees?
11. Can you provide the functionality to implement a fixed timetable-based transit system or does the current system already include this functionality? If not, can it be made available and at what price? Features we are interested in include the ability to set up route timetables, to report on schedule adherence to those fixed timetables, and to report back in "real-time" to drivers their performance in adhering to those timetables.
12. If the University decides to add additional signs (or roadside displays) described in your proposal, do you charge with the same rates as the four signs proposed in your proposal?
13. Please provide us with detailed drawings and specifications of your roadside information signs.

Trip Report to UCR Site Visit

1. General Information

On Wednesday, April 2, 2008, Glen Shenker, Richard Mou, and myself visited the University of California, Riverside (UCR) . The person we met was Mr. Lance Dankes, the Transit Manager of UCR. He first provided an overview of the UCR Shuttle System and then showed us almost all the features of the Syncromatics transit system for UCR Shuttle Service. Additionally, he gave us a tour of a UCR bus that has Syncromatics MDT and other devices.

Mr. Lance Dankes answered us all the questions. This trip report lists only the questions and answers that are related to the objectives of the EDAPTS research project.

2. Purpose

The purpose of this field trip was to clarify some features listed in the Syncromatics proposal that is submitted for the University's RFP No 07-014 "Bronco Express EDAPTS System."

3. Questions and Answers

Question #1: Does UCR system have a fixed timetable-based feature? If not, do you know if this type of functionality is available in Syncromatics transit system?

Answer # 1: UCR system has not implemented the fixed timetable feature in its Syncromatics transit system yet, even the timetable feature is available in the UCR system. Lance, acted as a dispatcher, showed us how to create a new route, add a new bus stop, and set up route timetables for the route. He said that the syncromatics system does have features to evaluate schedule adherence. However, the current UCR system does not have features to report schedule adherence information back in "real time" to drivers.

Question #2: Does UCR system have a Vehicle Emergency Alert function? If so, how does it function?

Answer #2 The UCR system currently does not have emergency alert capability. This feature is the one of features UCR would like to implement in the future.

Question #3 Does the UCR system experience any “down time”?

Answer # 3: The UCR system has not had any “down time” since the first day of the service, except one incident. One of the SIM cards was broken one day. The synchronomatics quickly sent the new SIM card. Lance easily replaced the old one using the same procedure as those used for replacing an old SIM card for a cell phone.

Question #4 Does you (Mr. Lance Dankes) like this type ITS system?

Answer #4 Mr. Dankes loves the system. He said he compared the synchronomatics system with others including one from New Zealand (he did not mention the name of the vendor). The reason he selected this system was that the system was of low costs, given similar features provided by the other systems. Other reason was that the system was easy to operate and maintain. It does not require dispatchers to have solid knowledge of Automatic Vehicle Location (AVL) systems, databases, computer servers, schedule adherence, and wireless/wire communication systems. All of technical work is handled by Synchronomatics. This type of business model is very good for small agencies running small fleet of buses for transit services. Normally small agencies do not have expertise knowing AVL tracking technologies.

Question #5 List the nice features related to sending bus arrival information to people in UCR.

Answer #5: The UCR system has a number of nice features that can send bus arrival information to people. People can use a PDA, an iPhone, a cell phone to get bus arrival information. The web site that shows the above features is <http://ucrshuttles.com>

The mobile features are located on the following web site: <http://ucrshuttles.com/mobile.aspx>

Question #6 Do you have signs (or dynamic information display signs) in the UCR Transit System?

Answer #6: No, UCR does not have any signs available yet. Mr. Bandes believes the current mobile features are sufficient for UCR.

4. Conclusions

This trip has made us clarify a number of issues related to Synchomatics ITS systems and their related features. I personally believe Synchomatics has met, to certain degree, the EDAPTS project requirements in the following ways:

1) EDAPTS Core Features

EDAPTS core features include AVL tracking, scheduling, traveler information services, and reporting functions. From this trip, I believe the UCR Synchomatics system does provide AVL tracking features, schedule adherence features (available but not implemented yet), and reporting functions. The mobile features provided in the systems are cutting-edge features. The only concerns we have are dynamic message display signs. We are not clear if signs meet the ADA requirements.

2) EDAPTS Low Cost, easy-to-use Theme

EDAPTS has a low cost theme. This type of ITS transit systems provides low cost, easy-to-use solutions to small transit agencies. From the trip, I believe the UCR system is easy to be operated and maintained. Users of the system are pleased with the system.

3) EDAPTS Performance Requirements

EDAPTS performance specifications define a quite number of performance requirements. To meet all these requirements is a challenging task. I believe the Synchomatics systems, to some degree, meet the performance requirements.

4) EDAPTS New Business Model

A traditional ITS solution to a transit agency is to purchase an ITS system, operate and maintain the system by the agency itself. This type of ITS solution, considered as “ITS Buying Solution” business model, is well suited to large transit agencies where financial and technical resources are easily provided. This traditional business model is not good for small or medium agencies. Normally small or medium agencies have limited financial and technical resources to install, operate, and maintain an ITS system by themselves.

EDAPTS New Business Model is to leverage technical burdens of small or medium transit agencies in deploying ITS solutions. Small or medium transit agencies do not need to own an ITS system by installing, operating, and maintaining it. They can rent ITS services. All the technical services (such as installation and maintenance of data bases and scheduling servers) are handled by ITS vendors. The transit agencies only focus on how to operate the ITS systems. This type of ITS solution can be considered as “Renting ITS Solution” business model.

Synchromatics provides an example of this type of “Renting ITS Solution” business model. As soon as a transit agency pays for reasonable monthly service fees, the agency can get bus location tracking features, scheduling services, dynamic message display services, mobile services, as well as reporting functions without considering how to maintain the ITS system. It is the same business model currently used by cell phone services. Cell phone users do not need to know the detailed technical requirements of cell phones, DPRS, and others, they just know how to use them.

I believe this is the future for small transit agencies.

AGREEMENT

AGREEMENT NUMBER 0000032228	AM NO
CONTRACTOR IDENTIFICATION NUMBER	

THIS AGREEMENT, made and entered into this 23rd day of April, 2008, in the State of California, by and between the Trustees of the California State University, which is the State of California acting in a higher education capacity, through its duly appointed and acting officer, hereinafter called CSU and

CONTRACTOR'S NAME
Syncromatics Corporation hereafter called Contractor,

WITNESSETH: That the Contractor for and in consideration of the covenants, conditions, agreements, and stipulation of the University hereinafter expressed, does hereby agree to furnish to the University services and materials as follows:

This agreement between **Syncromatics Corporation** and **California State Polytechnic University, Pomona**, Parking Transportation Services and **Grant Partners**, collectively referred to as "**Parties**" is to provide a Bronco Express EDAPTS (Efficient Deployment of Advanced Public Transportation System) in accordance with the following Exhibits, all of which are by this reference made a part of this agreement:

- Exhibit A**, Request for Proposal, RFP No. 07-014, dated February 8, 2008, consisting of fifty-three (53) pages;
- Exhibit B**, RFP No. 07-014, Addendum No. 1, dated February 28, 2008, consisting of one (1) page;
- Exhibit C**, Syncromatics Questions for the Demonstration Meeting on Thursday, April 17, 2008, consisting of two (2) pages;
- Exhibit D**, Syncromatics Corporation proposal submitted, dated February 27, 2008, consisting of thirty-five (35) pages;
- Exhibit E**, Syncromatics "FINAL QUOTE," consisting of one (1) page;
- Exhibit F**, Insurance Requirements for Services, consisting of one (1) page.

Continued on next page.....

IN WITNESS WHEREOF, the parties have executed this agreement hereto, upon the date first above written.

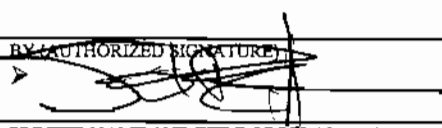
UNIVERSITY California State Polytechnic University, Pomona and Grant Partners of the Trustees of the California State University	CONTRACTOR Syncromatics Corporation
BY (AUTHORIZED SIGNATURE) ➤	BY (AUTHORIZED SIGNATURE) 
PRINTED NAME AND TITLE OF PERSON SIGNING Debra A. Garr Contract Specialist	PRINTED NAME AND TITLE OF PERSON SIGNING Josh Bigelow CEO
DEPT Procurement & Support Services	ADDRESS 547 N. Martel Ave., Los Angeles, CA 90036
AMOUNT ENCUMBERED BY THIS DOCUMENT \$73,005.00	REQUIRED CHARTFIELD DISTRIBUTION Account Fund Dept ID Program
TOTAL AMOUNT ENCUMBERED TO DATE \$	OPTIONAL CHARTFIELD DISTRIBUTION Class Proj/Grt

Upon approval of the Bronco Express EDAPTS signage by the Accessible Technology Initiative (ATI) Steering Committee review team, in accordance with the Trustees of the California State University Executive Order 926 and Exhibit C, the Parties reserve the right to exercise the following options as outlined in Exhibit A, Article 5.3 *Schedule, Milestone, and Deliverables*, Table 2, Task 2:

- Purchase three (3) additional Solar/wireless LED signs w/audio annunciation installed at the Parties' desired sites;

OR

- Purchase seven (7) additional Solar/wireless LED signs w/audio annunciation installed at the Parties' desired sites.

If the Parties find that the one "Solar/wireless LED sign with audio annunciation," purchased and paid for does not meet Section 508 standards, the Parties may choose to exercise the option in Exhibit D, Article 4.4 *Service Term*, 60-day money back guarantee. If the Accessible Technology Initiative (ATI) Steering Committee review team does not approve the signage, the Parties shall explore the other options described in Exhibit D, Article 6, *LED AND LCD SIGNAGE*. Upon mutual consent of the Parties and **Syncromatics Corporation**, an award shall be made to complete the Bronco Express EDAPTS (Efficient Deployment of Advanced Public Transportation System) contingent upon the availability of funding.

The following information is required for budget funding for the Bronco Express EDAPTS. See Exhibit A, RFP No. 07-014, Article 5.2, *Warranty and Maintenance Service Contract* pricing for "Technical and Maintenance Service Contracts":

Year 1 (18 months at the following rate) \$ 945.00 per month, includes one sign (\$65.00 ea. per additional sign)

Year 2 (12 months at the following rate) \$ _____ per month, includes one sign (\$ _____ ea. per additional sign)

Year 3 (12 months at the following rate) \$ _____ per month, includes one sign (\$ _____ ea. per additional sign)

Year 4 (12 months at the following rate) \$ _____ per month, includes one sign (\$ _____ ea. per additional sign)

Year 5 (12 months at the following rate) \$ _____ per month, includes one sign (\$ _____ ea. per additional sign)

Exhibit D, 2.6, page 10 of 35, Initial Training, shall be scheduled and coordinated through Glenn Shenker, Director of Parking and Transportation Services, for the on-site one-day initial training session.

Upon completion of this work to the satisfaction of the Parties and presentation of invoices (approved by the Dr. Xudong Jia, P.E., Project Manager) to the Cal Poly Pomona Foundation, Inc., the Parties will pay **Syncromatics Corporation** the total sum not to exceed **SEVENTY-THREE THOUSAND FIVE DOLLARS AND NO CENTS (\$73,005.00)** for services as specified.