

# UC Irvine

## UC Irvine Previously Published Works

### Title

Global Population Structure and Natural History of the Green Turtle (*Chelonia mydas*) in Terms of Matriarchal Phylogeny

### Permalink

<https://escholarship.org/uc/item/4xs4v4bd>

### Journal

Evolution, 46(4)

### ISSN

0014-3820

### Authors

Bowen, Brian W  
Meylan, Anne B  
Ross, J Perran  
et al.

### Publication Date

1992-08-01

### DOI

10.2307/2409742

### Copyright Information

This work is made available under the terms of a Creative Commons Attribution License, available at

<https://creativecommons.org/licenses/by/4.0/>

Peer reviewed

# EVOLUTION

INTERNATIONAL JOURNAL OF ORGANIC EVOLUTION

PUBLISHED BY  
THE SOCIETY FOR THE STUDY OF EVOLUTION

Vol. 46

August, 1992

No. 4

*Evolution*, 46(4), 1992, pp. 865-881

## GLOBAL POPULATION STRUCTURE AND NATURAL HISTORY OF THE GREEN TURTLE (*CHELONIA MYDAS*) IN TERMS OF MATRIARCHAL PHYLOGENY

BRIAN W. BOWEN,<sup>1</sup> ANNE B. MEYLAN,<sup>2</sup> J. PERRAN ROSS,<sup>3</sup> COLIN J. LIMPUS,<sup>4</sup>  
GEORGE H. BALAZS,<sup>5</sup> AND JOHN C. AVISE<sup>1,6</sup>

<sup>1</sup>*Department of Genetics, University of Georgia, Athens, GA 30602 USA*

<sup>2</sup>*Department of Natural Resources, Florida Marine Research Institute, 100 Eighth Ave.,  
S.E., St. Petersburg, FL 33701-5095 USA*

<sup>3</sup>*Department of Natural Sciences, Florida Museum of Natural History, Gainesville, FL 32611 USA*

<sup>4</sup>*Queensland National Park and Wildlife Service, P.O. Box 155, North Quay, Queensland, AUSTRALIA 4002*

<sup>5</sup>*National Marine Fisheries Service, Southwest Fisheries Science Center, Honolulu Laboratory,  
2570 Dole St., Honolulu HI 96822-2396 USA*

**Abstract.**—To address aspects of the evolution and natural history of green turtles, we assayed mitochondrial (mt) DNA genotypes from 226 specimens representing 15 major rookeries around the world. Phylogenetic analyses of these data revealed (1) a comparatively low level of mtDNA variability and a slow mtDNA evolutionary rate (relative to estimates for many other vertebrates); (2) a fundamental phylogenetic split distinguishing all green turtles in the Atlantic-Mediterranean from those in the Indian-Pacific Oceans; (3) no evidence for matrilineal distinctiveness of a commonly recognized taxonomic form in the East Pacific (the black turtle *C. m. agassizi* or *C. agassizi*); (4) in opposition to published hypotheses, a recent origin for the Ascension Island rookery, and its close genetic relationship to a geographically proximate rookery in Brazil; and (5) a geographic population substructure within each ocean basin (typically involving fixed or nearly fixed genotypic differences between nesting populations) that suggests a strong propensity for natal homing by females. Overall, the global matriarchal phylogeny of *Chelonia mydas* appears to have been shaped by both geography (ocean basin separations) and behavior (natal homing on regional or rookery-specific scales). The shallow evolutionary population structure within ocean basins likely results from demographic turnover (extinction and colonization) of rookeries over time frames that are short by evolutionary standards but long by ecological standards.

**Key words.**—Biogeography, *Chelonia agassizi*, *Chelonia mydas*, conservation genetics, mitochondrial DNA, molecular clock, molecular systematics, natal homing.

Received September 12, 1991. Accepted December 17, 1991.

The green turtle (*Chelonia mydas*) has a complex life history that is difficult to study directly because of the large spatial and temporal scales involved. Hatchlings and juveniles move among several habitats during development, adults migrate between feeding and nesting grounds that are hundreds

or thousands of kilometers apart, and both movements are difficult to track in the marine environment (Carr, 1980). Because only females ascend nesting beaches, much of what is known about the life history of marine turtles has come from tagging experiments on nesting females. Aspects of green turtle biology less amenable to direct observation have yielded to indirect (and often ingenious) methods. Reproductive histories

<sup>6</sup> To whom correspondence and reprint requests should be addressed.

have been studied with laparoscopy (Limpus and Reed, 1985), general migratory behaviors have been deduced from the growth patterns and species compositions of the epibiota on turtle carapaces (Eckert and Eckert, 1988), and turtle growth rates have been assessed by osteology and histology (Rhodin, 1985; Zug et al., 1986; Klinger and Musick, 1992). Another approach that may uncover otherwise intractable aspects of the natural history and evolution of marine turtles involves the assay of molecular genetic markers. In this study we employ mitochondrial (mt) DNA restriction site data to analyze matriarchal phylogeny and female-mediated gene flow among populations of *Chelonia mydas* from around the world.

The herbivorous green turtle inhabits tropical and subtropical feeding pastures in every major ocean basin. At intervals of 2 to 10 or more years, each mature female migrates from feeding grounds to a nesting locale, following routes that span hundreds or thousands of kilometers (Meylan, 1982). Green turtles nest colonially; in many locations, females utilize specific beaches while adjacent habitat remains unvisited (Carr and Carr, 1972). During a single nesting season, a female typically lays two to seven clutches of about 100 eggs each before returning to feeding grounds. Hatchlings emerge after an incubation period of eight weeks and enter an oceanic habitat where they may remain for several years (Carr, 1987). Juveniles eventually recruit to neritic foraging habitats and switch to the primarily herbivorous adult diet (Pritchard, 1976). Published estimates of first age at sexual maturity range from 27 to 33 years in the Atlantic (Frazer and Ladner, 1986), 30 or more years in Australia (Limpus and Walter, 1980), and 9 to 58 years in Hawaii (Balazs, 1982; see also Zug and Balazs, 1985).

Tagging data have demonstrated that mature females return quite faithfully to the same rookery for nesting in successive seasons (Carr and Ogren, 1960). This site fidelity led Carr (1967) and others to propose that adult females return to nest at their natal rookery. Hendrickson (1958) and Owens et al. (1982) proposed an alternative scenario also consistent with the nest-site fidelity of adult females. Under their "social facilitation" hypothesis, first-time breeders

follow experienced females to a nesting beach, and having had a "favorable" experience, fix on that site for future nesting. These hypotheses have proved difficult to test directly, as no known tag will persist through the transition from a 40 g hatchling to a 100 to 200 kg adult (Carr, 1986). Philopatry to natal site does, however, generate the testable prediction that rookeries should exhibit genetic differentiation with respect to female-transmitted traits (such as mtDNA), whereas social facilitation would allow high rates of female-mediated gene flow between rookeries that share feeding grounds. Tagging data indicate that nesting adults typically return to the same feeding grounds (Limpus et al., 1992), and these feeding pastures often are shared by turtles from several rookeries (Pritchard, 1976). This cooccupation of feeding pastures by females from different rookeries allows critical genetic tests of the social facilitation hypothesis.

In addition to contemporary behavioral components of population genetic structure, mtDNA analyses should reveal geographical and historical aspects of green turtle dispersal. Even if natal homing predominates, migrational "mistakes" must have occurred to account for the widespread distribution of rookeries. How high is intercolony gene flow within ocean basins, and what are the historical relationships among nesting colonies? Furthermore, the tropical and subtropical distribution of green turtles may prohibit gene flow between Atlantic and Indian-Pacific populations. When were these populations last connected?

mtDNA analysis may also demonstrate whether genetic partitions in the matriarchal phylogeny of green turtles agree with the putative population subdivisions and taxonomic units suggested from behavioral and morphological evidence. Basic life-history features are shared by all green turtle populations, but colonies show much variability in details of ethology and morphology (Mrosovsky, 1983). While describing these differences between regional populations, earlier researchers pondered the extent to which they reflect genetic or evolutionary divergence (Carr and Goodman, 1970). Opinions range from speculation that each nesting population is a distinct taxo-

onomic entity, to the possibility that essentially no evolutionary distinction exists even between populations in separate ocean basins (review in Mrosovsky, 1983; see also Bonhomme et al., 1987).

Finally, all of these issues are relevant to conservation efforts for this endangered species. In recent reports, mtDNA data on endangered species have proved useful for resolving population groupings in cases where morphological analyses were controversial or inconclusive (Awise, 1989; Bowen et al., 1991). Green turtles have been utilized widely by coastal cultures for thousands of years, but overharvesting in the last four centuries has driven several populations to extinction and has greatly diminished others (Parsons, 1962). Knowledge of the degree of demographic and evolutionary independence among rookeries is critically important to future management plans. As noted by Carr (1975), "It seems clear that if *Chelonia* is to get its share of concern as a group of vulnerable, threatened, and endangered forms of life, the composite nature of the *mydas* complex must be made known to conservationists and legislative governments." With these many issues in mind, we conducted the following global survey of green turtle rookeries.

## MATERIALS AND METHODS

### *Biological Samples*

Samples from 226 different nests were taken from the 15 Atlantic, Mediterranean, Indian, and Pacific Ocean nesting locations described in Table 1 and Figure 1. Sample sizes and locations were dictated by permit limitations as well as by biological criteria. International field collections typically required four to six permits and 6 to 18 months of advance correspondence. The nations and territories included in this study represent a subset of targeted locations for which permit agencies were accessible and receptive to biological research.

In deference to the endangered status of *C. mydas*, the sampling strategy was designed to minimize impact on natural populations. The high natural mortality of eggs and hatchlings made these the best candidates for collection. From each sampled nest, one hatchling or two eggs were taken. Two

eggs were necessary to offset mortality during transportation, as embryos are very sensitive to motion during the first few weeks of development (Limpus et al., 1979). Eggs were incubated for two to eight weeks before processing. Hatchlings were processed immediately following euthanasia. Because nestmates are normally expected to be identical in mtDNA genotype, the reported sample sizes refer to the number of different nests assayed.

### *Laboratory and Data Analysis Procedures*

Closed-circular mtDNA was isolated from soft tissues (hatchlings) or whole embryos (eggs) by CsCl-ethidium bromide density gradient centrifugation (Lansman et al., 1981). Purified mtDNAs were digested with the 17 informative four-, five- and six-base cutting restriction enzymes listed in Table 2. In addition, representative samples were digested with *AvaI*, *BamHI*, *BglI*, *BglII*, *BstEII*, *ClaI*, *KpnI*, *NsiI*, *PstI*, *SacI*, *Sall*, and *XbaI*, but these enzymes proved to be phylogenetically uninformative, producing either one or no cuts in our assays. Digestion fragments were end-labeled with <sup>35</sup>S nucleotides and separated on 1.0 to 1.7% agarose gels. When restriction changes involved small (<0.5 kb) fragments, patterns were confirmed using 5% acrylamide gels. Restriction fragments were visualized by autoradiography and assigned molecular weights on the basis of comparison to a 1-kb standard.

Estimates of nucleotide sequence divergence (*p* values) were calculated by the "site" approach of Nei and Li (1979), and haplotype and nucleotide diversities as defined by Nei and Tajima (1981) and Nei (1987). Relationships among mtDNA genotypes were assessed by UPGMA clustering (Sneath and Sokal, 1973), and by an exhaustive search of branching networks using parsimony criteria (Swofford and Olsen, 1990) in the computer program PAUP (version 3.0; Swofford, 1990). Statistical support for branches in the parsimony network were examined by bootstrapping 100 replicates (Swofford, 1990). Restriction fragment profiles were characterized with composite letter codes and these were joined into a par-

TABLE 1. Sample locations and population information.

Rookery location	N	Rookery size (females/year)	Feeding grounds	Comments	Refs.
<b>ATLANTIC</b>					
1) Ascension Island, UK	35	1,600–3,000	Brazilian Coast	Collections made in 1987 (N = 15) and 1990 (N = 20)	1
2) Atol das Rocas, Brazil	16	50–100	Unknown but probably includes Brazilian Coast	Appears to be declining	2
3) Matapica, Suriname	15	a few thousand	Brazilian Coast		3
4) Tortuguero, Costa Rica	15	5,000–23,000	Western Caribbean, primarily on coast of Nicaragua	Largest west Atlantic rookery	4
5) Aves Island, Venezuela	8	300–500	Caribbean, including Nicaragua	Declining	5
6) Hutchinson Island, FL USA	24	a few hundred along east coast of Florida	Unknown but probably includes Gulf of Mexico and Caribbean	Collections made in 1986 (N = 10) and 1990 (N = 14)	6
7) Pailoa, Guinea Bissau	13	about 400	Unknown		7
<b>MEDITERRANEAN</b>					
8) Lara Bay, Akamas Peninsula, Cyprus	10	fewer than 100	Mediterranean	Severely depleted by overfishing; may complete life cycle in Mediterranean	8
<b>INDIAN OCEAN</b>					
9) Ras Al Hadd, Oman	15	about 6,000	Gulf of Oman, Gulf of Aden, Red Sea		9
<b>PACIFIC OCEAN</b>					
10) Heron Island, Queensland, Australia	15	several thousand at Heron and adjacent cays	Arafura and Coral Seas to Vanuatu and Fiji	Primary nesting site in southern Great Barrier Reef	10
11) Ogasawara Archipelago, Japan	20	200–400	Pacific side of Japanese Archipelago and East China Sea	Largest rookery in northwest Pacific	11
12) French Frigate Shoals, Hawaii	22	100–500	Extend to both ends of archipelago	Collections made in 1986 (N = 12) and 1990 (N = 10); may complete all or most of life cycle within archipelago	12
13) Mopelia Atoll, French Polynesia	3	a few hundred	includes Fiji, New Caledonia, and Tonga		13
14) Michoacan, Mexico	7	1,000–3,000	Baja California, Central America, South America	Drastic decline in recent decades	14
15) Isabela Island, Galápagos, Ecuador	8	1,200–3,500 in archipelago	Costa Rica to Peru	May include resident and migratory turtles	15

1) Mortimer and Carr, 1987; Carr, 1975; 2) M. Marcovaldi, pers. comm.; Groombridge and Luxmoore, 1989; 3) Schulz, 1982; Pritchard, 1976; 4) Carr et al., 1978; 5) Sole and Medina, 1989; Pritchard and Trebbau, 1984; 6) Conley and Hoffman, 1987; 7) T. Agardy, pers. comm.; 8) Demetropoulos and Hadjichristophorou 1989; Demetropoulos and Hadjichristophorou 1987; Groombridge, 1988; 9) Ross and Barwani, 1982; Ross, 1985; 10) Limpus, 1982; Limpus et al., 1991; 11) H. Suganuma, pers. comm.; Sukanuma, 1985; 12) Balazs, 1976, 1980, and unpubl. data; 13) Pritchard, 1982; Lebeau, 1985; Meylan, 1982 and references therein; 14) Clifton et al. 1982; Alvarado and Figueroa, 1990; 15) Green, 1983; Green, 1984; Pritchard 1971.

simony network that interrelates observed restriction fragment patterns.

Because we are interested both in mean levels of divergence between rookeries and

genetic relationships of particular pairs of colonies (e.g., those that are adjacent, or share feeding grounds), some of the analyses described below include pairwise rookery

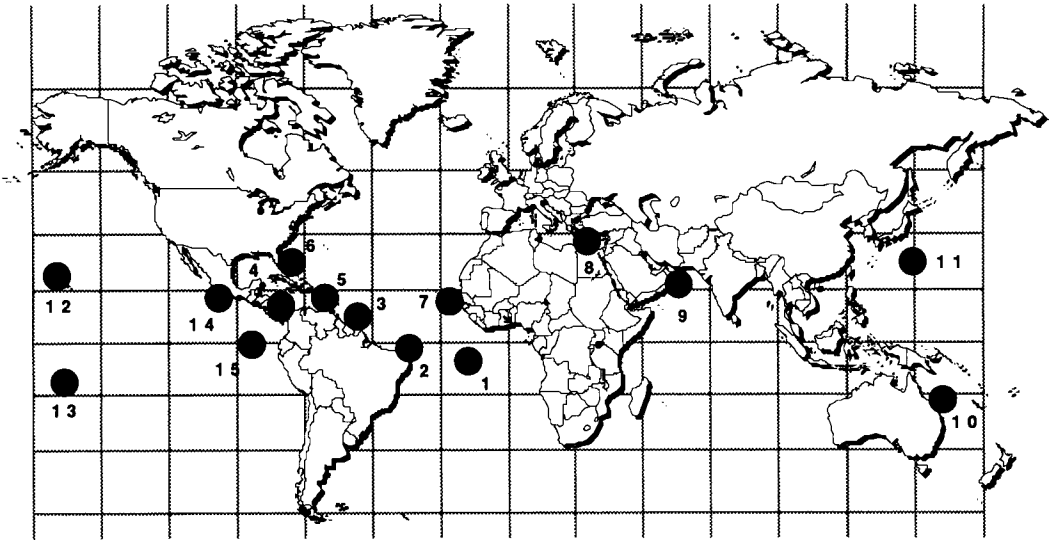

FIG. 1. Collection locales for *Chelonia mydas*. Numbers refer to localities described in Table 1.

comparisons (although results of pairwise comparisons are not independent). Pairs of rookeries were tested for significant differences in haplotype frequency by the *G* test with Yates' correction for small sample size

(Sokal and Rohlf, 1981). The cladistic approach of Slatkin and Maddison (1989) was used to generate pairwise estimates of *Nm* (where *N* is the size of each local population and *m* is the migration rate). In cases where

TABLE 2. Description and distribution of the 14 distinct mtDNA genotypes observed in green turtles collected at 15 rookeries. Italicized letters refer to mtDNA digestion profiles produced by (from left to right): *AvaII*, *BclI*, *BstNI*, *DdeI*, *DraI*, *DraII*, *EcoRI*, *EcoRV*, *HindII*, *HindIII*, *MboI*, *MspI*, *NdeI*, *PvuII*, *SpeI*, *SstII*, and *StuI*. Adjacent letters in the alphabet indicate that fragment profiles differ by a single restriction site; nonadjacent letters differ by at least two sites, with the exception of the *MspI* profiles in which A, B, and D differ from C by single restriction sites.

Code	mtDNA genotype	Rookery location	Number of nests
A	<i>ACCCCCCCCCCCCCDCC</i>	Florida, USA	21
		Tortuguero, Costa Rica	15
		Aves Island, Venezuela	1
B	<i>ACCCBCCCCCCCCDCC</i>	Florida, USA	3
C	<i>ACCCCCCBCCCCCCC</i>	Matapica, Suriname	15
		Aves Island, Venezuela	7
D	<i>ACCCCCCCCCCCCCCC</i>	Ascension Island, UK	34
		Atol das Rocas, Brazil	15
E	<i>ACCCCCCCCCCCCCCD</i>	Ascension Island, UK	1
F	<i>BCCCCBCCCCCCCCC</i>	Atol das Rocas, Brazil	1
G	<i>ACCCBCCCCCCCCCCC</i>	Pailoa, Guinea Bissau	13
H	<i>ACCCCCCCCCDCCCCC</i>	Lara, Cyprus	10
I	<i>CCCCBDCCCCDBBCD</i>	Ras Al Hadd, Oman	15
		Galapagos, Ecuador	8
		Michoacan, Mexico	7
		Hawaii, USA	6
J	<i>CCCCBECCCCDBBCD</i>	Hawaii, USA	16
K	<i>BCCCCBECCCCACBBCC</i>	French Polynesia	2
L	<i>CCCCBDCCCCBCBBCC</i>	Queensland, Australia	15
		French Polynesia	1
		Ogasawara Island, Japan	1
M	<i>CCCCBDCCCCDBBCC</i>	Ogasawara Island, Japan	5
N	<i>DCCCCDCCCCCBCC</i>	Ogasawara Island, Japan	14

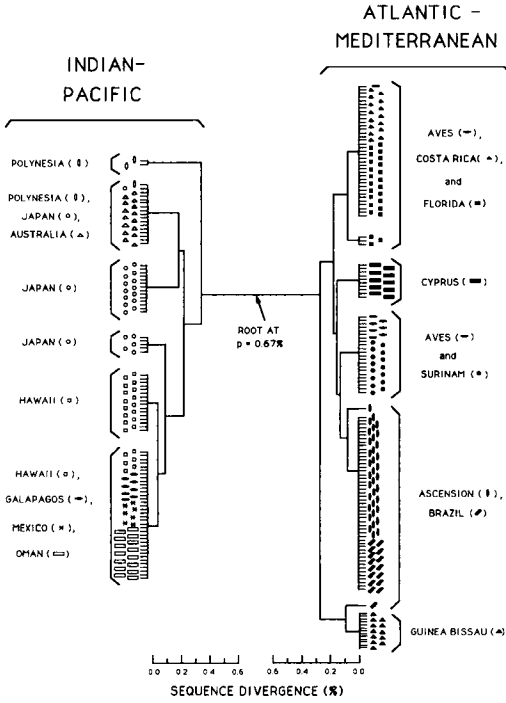
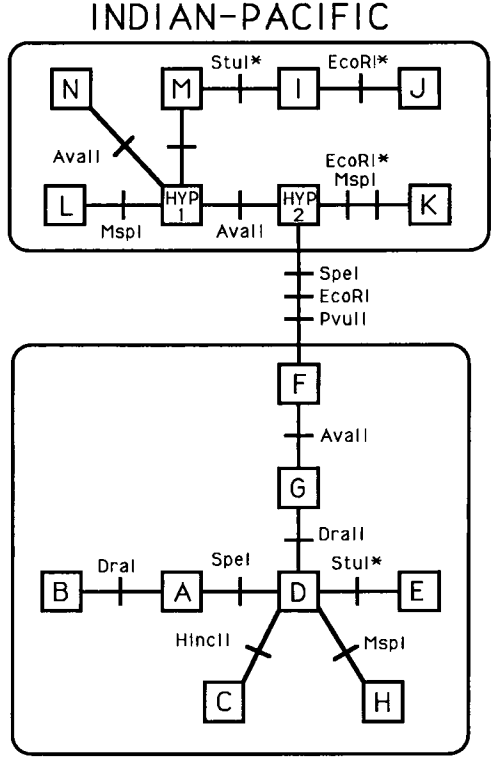

FIG. 2. UPGMA phenogram summarizing relationships among the 226 sampled nests of the green turtle. Note that to conserve space, the sequence divergence axes on the bottom are presented as mirror images centered around the placement of the root. The fundamental distinction between Atlantic-Mediterranean versus Indian-Pacific assemblages was also evidenced by strong bootstrap support (97% level) in parsimony analyses based on a presence/absence site matrix.

no genotypes were shared, an upper bound on the point estimate of  $Nm = 0$  was calculated by the approach described by Slatkin (1989). Pairwise estimates of  $Nm$  within each ocean basin were also calculated from  $G_{st}$  values ( $Nm = \frac{1}{2}(1/G_{st} - 1)$ )—Takahata and Palumbi, 1985). Finally, estimates of mean migration rate among rookeries within each ocean basin were calculated by the private-allele method (Slatkin, 1985), using the parameters and equation in Slatkin and Barton (1989). Due to small sample size, the Polynesia rookery data were excluded from pairwise comparisons ( $G$  test and  $Nm$  estimates).

RESULTS

A total of 14 distinct mtDNA haplotypes was observed among the 226 green turtles (Table 2), in assays that involved a mean



ATLANTIC-MEDITERRANEAN

FIG. 3. Parsimony network summarizing the interrelationships among the mtDNA fragment profiles, which are lettered as in Table 2. "Hyp 1" and "Hyp 2" represent hypothetical genotypes not observed in the current survey. Enzymes responsible for fragment pattern changes are indicated along branches, and the stars next to *Stul* and *EcoRI* indicate the only two instances in which homoplasy (convergent evolution to a common fragment pattern) has been assumed.

of 109 restriction sites scored per individual. Digestion profiles for all enzymes are presented in Bowen (1992). All restriction fragment changes could be accounted for by the gain or loss of particular restriction sites. Considered altogether, haplotypic and nucleotide diversities in the green turtle survey were 0.874 and 0.002, respectively.

Global Phylogeography

A striking feature of the mtDNA data is the phylogenetic grouping of observed haplotypes into two assemblages that correspond exactly to major oceanic basins: (1) the Atlantic Ocean and Mediterranean Sea; and (2) the Indian and Pacific Oceans (Figs. 2 and 3). All individuals from these two groups were separated by five or more re-

striction site changes (Fig. 3). Net nucleotide sequence divergence estimated between oceans (after correction for within-ocean variability) was  $p_{\text{corr}} = 0.0060$ . The interoceanic distinction is evident in both the UPGMA analysis (where the clusters join at  $p = 0.0067$ ), as well as in the parsimony analyses (where bootstrap support was at the 97% level).

#### *Intraoceanic Gene Flow*

Within the Atlantic-Mediterranean assemblage ( $N = 136$ ), eight different mtDNA genotypes were observed among the eight assayed rookeries (Fig. 3). Haplotypic and nucleotide diversities were 0.764 and 0.0005, respectively. Genotype frequencies differed significantly in 25 of 28 pairwise rookery comparisons (Table 3A), and many of these involved fixed haplotype distinctions in our samples (Table 2).

Within the Indian-Pacific assemblage ( $N = 90$ ), six different genotypes were observed among the seven assayed colonies (Fig. 3). Haplotypic and nucleotide diversities were 0.753 and 0.0008, respectively. Although two common genotypes ("I" and "L" in Table 2) were shared by several widely separated rookeries, genotype frequencies nonetheless differed significantly in 12 of 15 pairwise rookery comparisons (Table 3B).

Table 4 summarizes estimates of inter-rookery gene flow ( $Nm$ ) within the Atlantic-Mediterranean and Indian-Pacific groupings, based on Slatkin's (1989) cladistic approach and Takahata and Palumbi's (1985)  $G_{st}$  estimator. Most such values proved to be less than 1.0, indicating very little intercolony gene flow through females. Mean intraocean migration estimates based on the private allele approach are also consistent with this conclusion:  $Nm \cong 0.3$  for Atlantic-Mediterranean rookeries and  $Nm \cong 0.2$  for Indian-Pacific rookeries. In only the few cases where we could not distinguish rookeries in our assays were gene flow estimates higher (Tables 3 and 4). [We are skeptical that such colonies truly experience high contemporary gene flow, because (a) our assays may have failed to detect haplotype differences that do exist; and (b) these results might be due to recent historical connectedness—see below.]

In general, values for  $Nm$  greater than

approximately 1 to 4 indicate that gene flow is sufficiently high to maintain a relatively homogeneous mtDNA gene pool, whereas lower values indicate that gene flow is unlikely to retard genetic divergence of isolated gene pools by genetic drift (Slatkin, 1987; Birky et al., 1983). However, some caveats concerning these estimators should be mentioned. First, in this study these estimates are based on a single gene (mtDNA) genealogy. More precise estimates of migration rates would be expected from data involving multiple independent gene genealogies, where sampling errors introduced from single-locus estimates would be reduced. Second, assumptions of population equilibrium underlying some of these estimates of  $Nm$  may not be met. Last, the theoretical basis for these estimates has been developed only recently (Slatkin and Barton, 1989), and empirical calibrations currently are unavailable. Although  $Nm$  estimates from haploid data are useful for drawing qualitative conclusions, specific quantitative comparisons of  $Nm$  values should not be overinterpreted.

## DISCUSSION

### *Global Matriarchal Phylogeny and mtDNA Rate Calibration*

Phylogenetic relationships among mtDNAs from 15 globally distributed green turtle rookeries indicate a historical bifurcation of the *Chelonia mydas* complex into (1) the Indian and Pacific Oceans, and (2) the Atlantic Ocean and Mediterranean Sea. This genetic pattern is consistent with the geographic and climatic boundaries that currently define green turtle distributions. Populations from these two regions probably are isolated by the cold temperate conditions around the southern tips of Africa and especially of South America, whereas no physical barriers to movement now exist within the Atlantic-Mediterranean or within the Indian-Pacific Ocean basins. Thus the data from mtDNA lineages indicate that the geographic partitioning of the world's oceans by continental landmasses has been of overriding significance in shaping the global matriarchal phylogeny of *C. mydas*.

The overall magnitude of mtDNA sequence divergence in green turtles is low





TABLE 4.  $Nm$  values from Slatkin's (1989) cladistic approach (below diagonal) and Takahata and Palumbi's (1985)  $G_{st}$  estimator (above diagonal). The 95% confidence intervals for Slatkin's estimator are in parentheses.

A. ATLANTIC OCEAN AND MEDITERRANEAN SEA								
	I	II	III	IV	V	VI	VII	VIII
I Florida, USA	—	19.6	1.5	0.1	0.4	0.2	0.1	0.1
II Tortuguero, Costa Rica	0.4 (0–1.2)	—	1.3	0.0	0.3	0.1	0.0	0.0
III Aves Island, Venezuela	0.5 (0–2.4)	0.5 (0–2.4)	—	1.0	1.1	1.3	0.5	0.5
IV Matapica, Suriname	0.0 (0–0.3)	0.0 (0–0.3)	0.4 (0–1.2)	—	0.3	0.1	0.0	0.0
V Ascension Is., UK	0.0 (0–0.3)	0.0 (0–0.3)	0.0 (0–0.3)	0.0 (0–0.3)	—	1.3	0.3	0.3
VI Atol das Rocas, Brazil	0.0 (0–0.3)	0.0 (0–0.3)	0.0 (0–0.4)	0.0 (0–0.3)	0.4 (0–1.2)	—	0.1	0.1
VII Pailoa, Guinea Bissau	0.0 (0–0.3)	0.0 (0–0.3)	0.0 (0–0.4)	0.0 (0–0.3)	0.0 (0–0.3)	0.0 (0–0.3)	—	0.0
VIII Lara, Cyprus	0.0 (0–0.3)	0.0 (0–0.4)	0.0 (0–0.4)	0.0 (0–0.4)	0.0 (0–0.3)	0.0 (0–0.4)	0.0 (0–0.4)	—
B. INDIAN AND PACIFIC OCEANS								
	I	II	III	IV	V	VI		
I Ras al Hadd, Oman	—	0.0	0.7	0.3	High	High		
II Queensland, Australia	0.0 (0–0.3)	—	0.6	0.1	0.0	0.0		
III Ogasawara Is., Japan	0.0 (0–0.3)	0.4 (0–1.2)	—	0.6	0.7	0.7		
IV Hawaii, USA	0.4 (0–1.2)	0.0 (0–0.3)	0.0 (0–0.3)	—	0.3	0.3		
V Michoacan, Mexico	High	0.0 (0–0.4)	0.0 (0–0.4)	0.5 (0–2.4)	—	High		
VI Galápagos, Ecuador	High	0.0 (0–0.4)	0.0 (0–0.4)	0.5 (0–2.4)	High	—		

relative to many other assayed vertebrates (Wilson et al., 1985; Avise et al., 1987). If the Atlantic versus Pacific assemblages of green turtles have been isolated since the rise of the Isthmus of Panama some 3 million years ago (Lundelius, 1987), then net nucleotide divergence between the Atlantic and Pacific mtDNA lineages ( $P = 0.006$ , after correction for within-ocean divergence) is an order of magnitude lower than predicted under the "conventional" mtDNA clock calibration of 2% divergence per million years originally suggested for primates (Brown et al., 1979). However, a several-fold slower mtDNA rate (roughly 0.2 to 0.4% between lineages per million years) has been suggested for other marine, freshwater, and terrestrial turtles (order Testudines) (Bowen et al., 1991; Avise et al.,

1992). Under such clock calibrations, Atlantic and Pacific populations of *C. mydas* may have been isolated for 1.5 to 3 million years.

However, estimated times of lineage separation must be interpreted with caution, and we cannot rule out the possibility that Atlantic and Pacific turtles shared a common ancestor subsequent to formation of the Panama Isthmus. The Cape of Good Hope is not an impermeable barrier to tropical species (Briggs, 1974), and this route might have provided a more recent link between Atlantic and Indian-Pacific green turtle populations. The fact that South and East Atlantic genotypes ("F" and "G" in Fig. 3) are the closest Atlantic relatives to Indian-Pacific mtDNAs may be interpreted as support for this scenario. However, the

converse expectation, that an Indian Ocean genotype is the closest Indian-Pacific relative to Atlantic mtDNAs, is not met with our single Indian Ocean rookery sample ( $N = 15$ ). The Indian-Pacific mtDNA lineages most closely related to those in the Atlantic ("K," "L," "M," and "N"—Fig. 3) are found in the central and west Pacific. This pattern could be construed as evidence that the most recent contact between Atlantic and Indian-Pacific populations was through the east Pacific rather than from the Indian Ocean via the Cape of Good Hope. While this issue remains unresolved, we note that the Indian Ocean was not well sampled in this survey. It is possible that samples from other major Indian Ocean rookeries could resolve this question.

#### *Intraoceanic Distribution of mtDNA Lineages*

Green turtle nesting populations within ocean basins also exhibit significant geographic structure with respect to mtDNA genotype frequencies (Table 3), although the magnitudes of estimated sequence divergence among the haplotypes involved are considerably lower than those between the Atlantic-Mediterranean and Indian-Pacific Oceans (Fig. 2). With the exception of one individual from Brazil (genotype "F"—Fig. 3), no observed Atlantic genotype is more than three assayed restriction site changes removed from any other in the Atlantic. The shallow separation of Atlantic mtDNA lineages suggests that no physical impediments to green turtle dispersal have existed in the tropical Atlantic during recent evolutionary history. This interpretation is consistent with the known geologic history of the Atlantic Ocean basin.

The shallow evolutionary depth in the mtDNA phylogeny also suggests that the particular phylogeographic structure of female lineages within the Atlantic-Mediterranean realm is probably transient over evolutionary time spans. Carr and Coleman (1974) proposed an ancient (70 mya) origin for the Ascension Island green turtle nesting colony, based on a hypothesized colonization event of a proto-Ascension Island soon after the Cretaceous opening of the South Atlantic by plate tectonic movement. The mtDNA data are consistent with the iso-

lation of Ascension Island from most other Atlantic rookeries, but over a vastly shorter time scale (Bowen et al., 1989). With the addition of data from more rookeries in the current study, it appears that the closest maternal relatives of Ascension Island turtles occur in the geographically proximate Brazilian site, the only other locale where the mtDNA haplotype that is nearly fixed on Ascension Island ("D", Table 2) was observed.

Overall, we interpret the shallow separations in the entire Atlantic-Mediterranean mtDNA phylogeny to indicate that female breeding assemblages have been connected relatively recently in evolutionary time, probably through processes of rookery extinction and colonization. Climatic and geologic events (e.g., hurricanes, sea level changes) no doubt create and destroy green turtle nesting habitat, and thereby influence rookery turnover, with net effect that all turtles within the Atlantic-Mediterranean share a common ancestor more recently than would have been the case under longstanding rookery isolations. Based on the mtDNA clock calibrations for Testudines suggested above (0.2 to 0.4% sequence divergence per million years), all breeding populations within the Atlantic appear to have shared a common ancestor within the last 0.5 to 1.0 million years.

The Indian-Pacific Ocean mtDNA phylogeny has somewhat deeper mtDNA branches (Fig. 2). Genetic distances between haplotypes range from  $P = 0.0008$  to  $0.0044$  (as compared to Atlantic-Mediterranean distances of  $P = 0.0008$  to  $0.0034$ , or of  $P = 0.0008$  to  $0.0027$  if we exclude the one individual with genotype "F"). Several factors may have contributed to this pattern. First, fewer localities were sampled from a much wider area. Second, the deeper nodes may reflect a larger total population size for green turtles in this oceanic basin (see Avise et al., 1988). Another influence may involve the geography of the shallow Indo-Pacific continental shelf. The Torres Strait, which separates Australia from Papua New Guinea, was exposed repeatedly during periods of lower sea level associated with Pleistocene glacial epochs (Doutch, 1972). In these circumstances, Australia and Papua New Guinea constituted a continuous land bar-

rier across tropical and temperate zones of the south Pacific. Partial barriers also may have existed between Indonesia and southeast Asia during glacial maxima. Thus gene flow across the Indo-Pacific may have been restricted or curtailed intermittently. Another possible factor involves habitat availability. The Pacific Basin includes broad stretches of open ocean "desert" in which adult green turtle habitats (both feeding and nesting) are absent. For example, the east Pacific is widely recognized as a formidable zoogeographic barrier for nonpelagic organisms (Briggs, 1974). Thus, the patchy distribution of green turtle habitat in the Indian and Pacific Oceans may contribute to deeper phylogenetic separations than observed in the Atlantic.

On the other hand, recent connection among Indian and Pacific rookeries is also indicated, as judged by the widespread distribution of haplotypes "I" and "L" (Table 2; Fig. 2). Curiously, "I" was shared by rookeries in the East Pacific, Central Pacific, and Indian Oceans, but absent in our collections from the Western Pacific. Based on the distribution of this mtDNA genotype, Indian Ocean and East Pacific lineages may be more closely related to each other than to the spatially intermediate rookeries in Australia and Japan.

#### *Systematics of the Chelonia mydas Complex*

The behaviors and morphologies of green turtles vary geographically. With respect to behavior, nesting seasons differ widely in timing and duration, even among rookeries in the same region (Pritchard, 1980). Some locales support both nesting and feeding aggregates, and nonmigratory populations may exist at these sites (Pritchard, 1971; Carr, 1980; but see Limpus et al., 1992). With respect to morphology, South Atlantic nesters are notably larger than Caribbean nesters (Carr and Goodman, 1970), which in turn are larger than those in the East Pacific (Pritchard, 1979; Figueroa, 1989) and Mediterranean. From these and related considerations, subspecific status has been proposed for numerous regional forms of the green turtle, including populations in the Caribbean (*C. m. viridis*), South Atlantic (*C. m. mydas*), Indo-west Pacific (*C. m. japon-*

*ica*), Gulf of California (*C. m. carrinegra*), and East Pacific (*C. m. agassizi*) (reviews in Carr, 1975; Pritchard and Trebbau, 1984; Groombridge and Luxmoore, 1989).

The east Pacific form is often accorded full species status: *C. agassizi*, the black turtle. These turtles tend to be distinguishable by carapace shape, small size, and dark coloration (Figueroa and Alvarado, 1990; Alvarado and Figueroa, 1990). However, light colored *C. mydas*-type individuals also nest at major East Pacific rookeries (Carr, 1961; Pritchard, 1971).

The divergence of Atlantic-Mediterranean and Indian-Pacific mtDNA genotypes (Figs. 2 and 3) is compatible with geographic considerations for *C. mydas*, but conflicts with the widely accepted taxonomic distinction for *C. m. agassizi*. Similar conflicts, in which molecular partitions are concordant with zoogeographic boundaries but not with taxonomic boundaries, have been noted in other recent studies (Avise, 1989; Meyer et al., 1990). Although we cannot exclude the possibility of undetected mtDNA phylads in putative *C. m. agassizi* populations, such lineages would have to occur at rather low frequency in the Galápagos ( $N = 8$ ) and Michoacan, Mexico ( $N = 7$ ) to have escaped detection in this survey. Notably, these locations represent two of the major *C. m. agassizi* rookeries.

Although mtDNA data do not support the evolutionary distinctiveness of *C. m. agassizi*, any taxonomic determination should rest on multiple lines of evidence. In the case of ridley sea turtles (*Lepidochelys* spp.), conclusions drawn from morphology and mtDNA data independently corroborate the evolutionary distinctiveness of *L. kempi* from *L. olivacea* (Bowen et al., 1991). Thus additional lines of evidence, including those from nuclear gene assays (Hendrickson, 1979, 1980; Karl et al., 1992), are desirable before final conclusions on *C. m. agassizi* are drawn. If the global pattern observed in the mtDNA phylogeny is corroborated with other evidence, then the *Chelonia* complex should probably be divided into Atlantic-Mediterranean and Indian-Pacific subspecies, with additional population-level differentiation recognized within each ocean basin. Under this scenario, the Indian-Pacific green turtle subspecies should

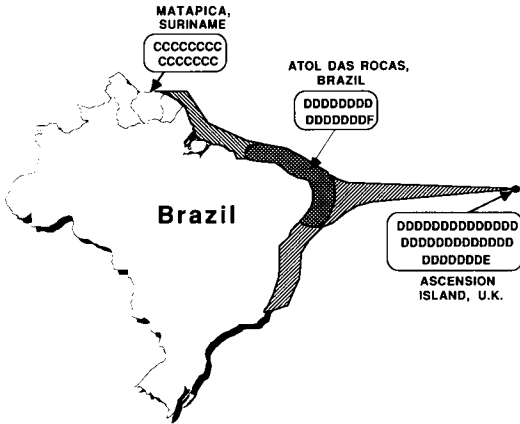

FIG. 4. MtDNA genotypes observed at the Ascension Island, Surinam, and Brazilian green turtle rookeries. Also shown (by cross-hatching) is the region of overlap on feeding grounds (as indicated by tag recoveries) for females that nest at the Ascension and Surinam rookeries (modified from Carr, 1975).

be named *japonica*, because that designation predates *agassizi* (Carr, 1952).

#### *Natal Homing and Migratory Behavior*

Carr (1967) proposed natal homing as an extension of the nest site fidelity observed for adult females. Hendrickson (1958) suggested an alternative "social-facilitation" hypothesis, whereby neophyte nesters follow experienced females from feeding grounds to rookery (see also Owens et al., 1982). Under the natal homing hypothesis, each rookery is expected to constitute an isolated population of female lineages, whereas under social facilitation, female lineages would be shared among rookeries whose feeding grounds overlap (Meylan et al., 1990). In preliminary genetic surveys, observed geographic structuring of mtDNA genotypes proved consistent with the natal homing hypothesis (Bowen et al., 1989; Meylan et al., 1990). The current study provides further evidence for restrictions on female-mediated gene flow between most breeding populations (Table 4).

For the most part, our collecting locations outside the Atlantic are too widespread to provide additional critical tests of the social facilitation hypothesis. However, the present study does add one strong test case, involving a comparison of the Ascension Island ( $N = 35$ ), Suriname ( $N = 15$ ), and Brazil ( $N = 16$ ) rookeries. The major feeding

grounds for Surinam turtles, and the only known feeding grounds for Ascension and Brazilian turtles, are along the Atlantic coast of South America (Fig. 4) (Carr, 1975; Schulz, 1982). Tagging data demonstrate that turtles from the Ascension and Surinam rookeries overlap extensively on these feeding grounds (Pritchard, 1976; Carr, 1975), yet no turtle tagged at one rookery has been observed nesting at the other. In this report (with a combined sample of  $N = 66$  for these three rookeries), the Surinam rookery sample contains a genotype at 100% frequency that has not been observed at Atol das Rocas or Ascension Island (Fig. 4). Despite overlap on feeding grounds, these genetic data indicate a behaviorally maintained barrier to female dispersal between nesting populations, and thus are consistent with natal homing expectations.

In light of the shallow mtDNA separations of rookeries within ocean basins, Bowen et al. (1989) suggested that imprinting on environmental cues, rather than site-specific genetic programming, is responsible for nest site choice. Genetically ordained homing to particular locations would presumably require generations of intense selection, whereas imprinting would allow novel migratory circuits to be established in a single generation. Notably, tagging data have suggested that adults return faithfully to the same feeding area between reproductive periods (Limpus et al., 1992). If green turtles also imprint on particular feeding grounds (perhaps at the end of their pelagic juvenile stage—Limpus et al., 1992), then both ends of their nesting-feeding migrational circuits would be anchored by imprinting behavior.

#### *The Evolutionary Lifespan of Rookeries*

Evidence concerning the temporal lifespan of rookeries is scarce. Fossil green turtle bones that date (by proximity to other carbon-dated fossils) to 1,100 years bp have been found at an active rookery at Raine Island, Queensland (Limpus, 1987). The vertical margins of this coral cay almost certainly precluded nesting during lower sea levels associated with the Wisconsin glaciation (18,000–10,000 years bp), such that the colony is probably between 1,100 and 10,000 years old. At Ascension Island, steep

cliffs predominate above and below the water line. The sea-level drop associated with the Wisconsin glacial interval (estimated at 100 meters—Bowen, 1978) may have precluded nesting here as well. In addition to sea level changes, global cooling associated with Pleistocene glacial advances no doubt reduced the northern and southern limits of green turtle nesting. Hedgpeth (1954) demonstrated that the temperate Atlantic fauna extended well south of the Florida peninsula during the Wisconsin glaciation, and cool temperate conditions also extended into the eastern Mediterranean (Buckley et al., 1982). Thus the sites of present-day rookeries in Florida and Cyprus were probably too cool to support nesting even 10,000 years ago.

Feeding grounds may be transient as well. The continental shelf of Brazil, which currently supports one of the largest green turtle feeding grounds in the Atlantic, ends less than 100 meters below current sea level (Moll, 1983). Thus at times of lower sea level these feeding grounds were probably displaced or highly compressed.

Given the brief duration of rookeries over geologic timescales, absolute natal homing would be a recipe for extinction. As climatic fluctuations alter the availability of green turtle habitat, new nesting beaches and feeding grounds must be colonized by turtles hatched elsewhere. As noted by Carr et al. (1978), "Strays and wandering must occur, and are no doubt adaptively advantageous aberrations, necessary for colony proliferation . . ." In the cases noted above, green turtle feeding and nesting habitats probably have been colonized within the last 500 green turtle generations. Thus, the shallow population structure observed within ocean basins is probably understandable in terms of the temporal lifespans of green turtle habitat.

Considering the ephemeral nature of rookeries, it is perhaps surprising that detectable genetic structure exists. Under neutrality theory, mtDNA gene trees are expected to be concordant with population structure only after about  $2N_{(e)}$  generations of population isolation (Neigel and Avise, 1986; Pamilo and Nei, 1988), where  $N_{(e)}$  is the evolutionary effective population size of females. One consequence of this lineage sorting process is that a longer generation

length is expected to increase the chronological time required for gene lineages within an ancestral population to resolve into distinct genetic lineages in isolated daughter populations (Bowen and Avise, 1990). Any analysis of green turtle population genetic processes must weigh the consideration that green turtle generations are an order of magnitude longer than those of most vertebrates. If we conservatively assume a generation length of 20 years, and an  $N_{(e)}$  of 1,000 per rookery, then green turtle populations would require 40,000 years on average to evolve fixed lineage differences (as observed between Ascension and Suriname). Organisms with longer generation lengths or larger populations would require greater times to attain reciprocal monophyly. These time intervals are probably considerably longer than the evolutionary life span of most rookeries.

Why then are green turtle female lineages geographically structured under these ephemeral conditions? One possibility is that new nesting beaches may be colonized by only one or a few gravid females, leading to rapid fixation of a mtDNA genotype in the neophyte rookery. The low nucleotide diversity within most surveyed rookeries may be construed as evidence supporting this possibility. In our assays, most rookeries (12 of 15) exhibited only one mtDNA haplotype or two haplotypes that differed by a single restriction site change (Table 2). Only the Japanese and Polynesian samples contain divergent genotypes that necessitate a hypothesis of multiple colonization events.

#### *Management Implications*

Natal homing on a regional or rookery-specific basis appears to be a dominant force shaping female green turtle population structure. However, a low level of leakage presumably exists that enables exploitation of new habitat. What role do "gravid waifs" have in the demography and hence management of rookery populations? Colonization events probably occur on a time scale of thousands of years. While this is an important evolutionary consideration, estimates of migration (Table 4) indicate that gene flow between rookeries is too low to significantly impact recruitment on a contemporary scale. In terms of conservation

and management, mtDNA data indicate that rookeries must be considered independent demographically. It is notable that rookeries extirpated over the last four centuries (including Grand Cayman, Bermuda, and Alto Velo) have not been recolonized by natural recruitment (Parsons, 1962). Thus both historical records and current genetic evidence indicate that overharvesting of nesting assemblages is not compensated by recruitment from other rookeries. Because the production of progeny ultimately depends on female nesting success, the conclusion that rookeries must be managed independently holds even if males should prove not to be philopatric to natal site.

### *Prospectus*

The current study has addressed only the matrilineal component of population structure and natural history in *C. mydas*. The biology of this species is such that matriarchal pedigrees are of special relevance to the issues of demographic independence of rookeries and natal homing by green turtles. Many questions that remain about the natural history of green turtles involve male behaviors. Because males seldom come ashore where they might otherwise be observed and tagged (but see Balazs, 1983), little is known concerning their dispersal and migratory behavior, the mating system, or whether males provide a significant avenue of gene flow between some of the rookeries that we now know to be nearly completely isolated with respect to female lineages. In a companion report, we empirically address these issues from the perspective of nuclear gene analyses (Karl et al., 1992).

### ACKNOWLEDGMENTS

This project was made possible by the outstanding contributions of T. Agardy, A. Demetropoulos, L. Fowler, M. Hadjichristophorou, C. Lagueur, J.-P. Landret, M. Marcovaldi, G. Medina, W. Nelson, H. Reichart, J. Richardson, B. Schroeder, H. Suganuma, I. Uchida, and R. Witham. For field assistance we gratefully recognize the participation of J. R. Bowen, R. Byles, R. Cumming, L. Ehrhart, J. Frazier, E. Fowler, P. Galenon, S. Grand, S. Karl, R. Klinger, M. Major, G. Marcovaldi, E. Martin, P. Meylan, G. Nakai, K. Neithammer, D. Ow-

ens, and J. Zurita. For logistic support and permits we are indebted to R. M. Ball, J. Beale, J. Bennett, M. Blick, C. de Blohm, B. Campbell, R. Carlson, D. Carr, C. Carson, G. Childress, S. Cornelius, F. Cortez, G. Cruz, R. Engleman, E. T. Fritch, D. Green, M. Hare, K. Horikoshi, J. A. Huff, M. Hurtado, H. Kasai, D. McDermond, M. McDowell, K. Mohadin, K. Mount, J. Musick, J. Norman, E. Possardt, K. Scribner, M. Tracey, P. Siu, J. Woody, J. Young, the American Museum of Natural History, Administrative Office of Ascension Island (UK), Applied Biology Inc., Caribbean Conservation Corp., Charles Darwin Research Station, Cyprus Wildlife Society, Delta Airlines, Direcçao-Geral dos Servicos Florestais e Caça (Guinea Bissau), Establisement pour la Valorisation des Activites Aquacoles et Maritimes (French Polynesia), Florida Department of Natural Resources, Fundacion para la Defensa de la Naturaleza (Venezuela), Fundacao Brasileira Para A Conservacao da Naturaleza, Government of Ecuador, Ministry of Agriculture and Natural Resources (Cyprus), National Marine Fisheries Service (USA), Projeto Tartaruga Marinha (TAMAR) (Brazil), Queensland National Parks and Wildlife Service, Servicio de Parques Nacionales de Costa Rica, Servicio Parque Nacional Galápagos, Ministry of Fisheries (Sultanate of Oman), Surinam Forest Service, STI-NASU (Suriname), U.S. Air Force, U.S. Fish and Wildlife Service, and World Wildlife Fund. We thank K. Bjorndal and P. Meylan for insightful reviews of an earlier draft of this manuscript. This research was supported by grants from the National Geographic Society and the National Science Foundation, and by a Genetics Training grant to BWB from the National Institute of Health.

### LITERATURE CITED

- ALVARADO, J., AND A. FIGUEROA. 1990. The ecological recovery of sea turtles of Michoacan, Mexico. Special attention: The black turtle, *Chelonia agassizi*. Final report submitted to U.S. Fish and Wildlife Service, Albuquerque, New Mexico, and World Wildlife Fund, Wash., DC USA.
- AVISE, J. C. 1989. A role for molecular genetics in the recognition and conservation of endangered species. *Tr. Ecol. Evol.* 4:279-281.
- AVISE, J. C., J. ARNOLD, R. M. BALL, E. BIRMINGHAM, T. LAMB, J. E. NEIGEL, C. A. REEB, AND N. C.

- SAUNDERS. 1987. Intraspecific phylogeography: The mitochondrial DNA bridge between population genetics and systematics. *Annu. Rev. Ecol. Syst.* 18:489-522.
- AVISE, J. C., R. M. BALL, AND J. ARNOLD. 1988. Current versus historical population sizes in vertebrate species with high gene flow: A comparison based on mitochondrial DNA lineages and inbreeding theory for neutral mutations. *Mol. Biol. Evol.* 5: 331-344.
- AVISE, J. C., B. W. BOWEN, T. LAMB, A. B. MEYLAN, AND E. BERMINGHAM. 1992. Mitochondrial DNA evolution at a turtle's pace: Evidence for low genetic variability and reduced microevolutionary rate in the Testudines. *Mol. Biol. Evol.* 9:457-473.
- BALAZS, G. H. 1976. Green turtle migrations in the Hawaiian archipelago. *Biol. Conserv.* 9:125-140.
- . 1980. Synopsis of biological data on the green turtle in the Hawaiian Islands. U.S. Dept. Commer., NOAA Tech. Memo. NMFS, NOAA-TM-NMFS-SWFC-7, and University of Hawaii Sea Grant Cooperative Report UNIHI-SEAGRANT CR-81-02.
- . 1982. Growth rates of immature green turtles in the Hawaiian Archipelago, pp. 117-125. *In* K. A. Bjorndal (ed.), *Biology and Conservation of Sea Turtles*. Smithsonian Institution Press, Wash., DC USA.
- . 1983. Recovery records of adult green turtles observed or originally tagged at French Frigate Shoals, Northwestern Hawaiian Islands. U.S. Dept. Commer., NOAA Tech. Memo. NMFS, NOAA-TM-NMFS-SWFC-36.
- BIRKY, C. W., JR., T. MARUYAMA, AND P. FUERST. 1983. An approach to population and evolutionary genetic theory for genes in mitochondria and chloroplasts, and some results. *Genetics* 103:513-527.
- BONHOMME, F., S. SALVIDIO, A. LEBEAU, AND G. PASTEUR. 1987. Comparison genetique des tortues vertes (*Chelonia mydas*) des Oceans Atlantique, Indien et Pacifique: Une illustration apparente de la theorie mullerienne classique de la structure genetique des populations? *Genetica* 74:89-94.
- BOWEN, B. W. 1992. Evolutionary genetics and natural history of marine turtles. Ph.D. Diss. University of Georgia, Athens, USA.
- BOWEN, B. W., AND J. C. AVISE. 1990. Genetic structure of Atlantic and Gulf of Mexico populations of sea bass, menhaden, and sturgeon: Influence of zoogeographic factors and life-history patterns. *Mar. Biol.* 107:371-381.
- BOWEN, B. W., A. B. MEYLAN, AND J. C. AVISE. 1989. An odyssey of the green turtle: Ascension Island revisited. *Proc. Nat. Acad. Sci. USA* 86:573-576.
- . 1991. Evolutionary distinctiveness of the endangered Kemp's ridley sea turtle. *Nature* 352:709-711.
- BOWEN, D. Q. 1978. *Quaternary Geology*. Pergamon Press, Oxford, UK.
- BRIGGS, J. C. 1974. *Marine Zoogeography*. McGraw-Hill, N.Y., USA.
- BROWN, W. M., M. GEORGE, JR., AND A. C. WILSON. 1979. Rapid evolution of animal mitochondrial DNA. *Proc. Nat. Acad. Sci. USA* 76:1967-1971.
- BUCKLEY, H. A., L. R. JOHNSON, N. J. SHACKLETON, AND R. A. BLOW. 1982. Late glacial to recent cores from the eastern Mediterranean. *Deep Sea Res.* 29: 739-766.
- CARR, A. 1952. *Handbook of Turtles. The Turtles of the United States, Canada, and Baja California*. Cornell University Press, Ithaca, NY USA.
- . 1961. Pacific turtle problem. *Nat. Hist.* 70(8): 64-71.
- . 1967. *So Excellent a Fish: A Natural History of Sea Turtles*. Scribner, N.Y., USA.
- . 1975. The Ascension Island green turtle colony. *Copeia* 1975:547-555.
- . 1980. Some problems of sea turtle ecology. *Am. Zool.* 20:489-498.
- . 1986. Rips, FADS, and little loggerheads. *Bioscience* 36(2):92-100.
- . 1987. New perspectives on the pelagic stage of sea turtle development. *Conserv. Biol.* 1:103-121.
- CARR, A., AND M. H. CARR. 1972. Site fixity in the Caribbean green turtle. *Ecology* 53(3):425-429.
- CARR, A., M. H. CARR, AND A. B. MEYLAN. 1978. The ecology and migrations of sea turtles, 7. The west Caribbean green turtle colony. *Bull. Am. Mus. Nat. Hist.* 162:1-46.
- CARR, A., AND P. J. COLEMAN. 1974. Seafloor spreading theory and the odyssey of the green turtle from Brazil to Ascension Island, Central Atlantic. *Nature* 249:128-130.
- CARR, A., AND D. GOODMAN. 1970. Ecologic implications of size and growth in *Chelonia*. *Copeia* 1970: 783-786.
- CARR, A., AND L. OGREN. 1960. The ecology and migrations of sea turtles, IV: The green turtle in the Caribbean Sea. *Bull. Am. Mus. Nat. Hist.* 121:1-48.
- CLIFFTON, K., D. O. CORNEJO, AND R. S. FELGER. 1982. Sea turtles of the Pacific coast of Mexico, pp. 199-210. *In* K. A. Bjorndal (ed.), *Biology and Conservation of Sea Turtles*. Smithsonian Institution Press, Wash., DC USA.
- CONLEY, W., AND B. HOFFMAN. 1987. Nesting activity of sea turtles in Florida, 1979-1985. *Fla. Sci.* 50:201-210.
- DEMETROPOULOS, A., AND M. HADJICHRISTOPHOROU. 1987. Turtles and turtle conservation in Cyprus (handout to visitors at the Lara Turtle Station). Department of Fisheries, Nicosia, Cyprus.
- . 1989. Sea turtle conservation in Cyprus. *Marine Turtle Newsletter* 44:4-6.
- DOUTCH, H. F. 1972. The paleogeography of northern Australia and New Guinea and its relevance to the Torres Strait area, pp. 1-10. *In* D. Walker (ed.), *Bridges and Barriers: The Natural History and Cultural History of the Torres Strait*. Australian National University Press, Canberra, Australia.
- ECKERT, K. L., AND S. A. ECKERT. 1988. Pre-reproductive movements of leatherback sea turtles (*Dermochelys coriacea*) nesting in the Caribbean. *Copeia* 1988:400-406.
- FIGUEROA, A. 1989. Contribucion a la determinacion del estatus taxonomico de la tortuga negra (*Chelonia agassizi* Bocourt, 1868) de Michoacan, Mexico. Ph.D. Diss. Universidad Michoacana de San Nicholas de Hidalgo, Morelia, Michoacan, Mexico.
- FIGUEROA, A., AND J. ALVARADO. 1990. Morphometric comparison of the *Chelonia* populations of



- Michoacan, Mexico and Tortuguero, Costa Rica, pp. 179–182. In T. H. Richardson, J. I. Richardson, and M. Donnelly (compilers), Proceedings of the Tenth Annual Workshop on Sea Turtle Biology and Conservation. NOAA Tech. Memo. NMFS-SEFC-278.
- FRAZER, N. B., AND R. C. LADNER. 1986. A growth curve for green sea turtles, *Chelonia mydas*, in the U.S. Virgin Islands. *Copeia* 1986:798–802.
- GREEN, D. 1983. Galápagos sea turtles. *Notic. Galap.* 38:22–25.
- . 1984. Long distance movements of Galápagos green turtles. *J. Herpetol.* 18:121–130.
- GROOMBRIDGE, B. 1988. Marine turtles in the Mediterranean; distribution, population status, conservation. Report to the Council of Europe Environment Conservation and Management Division T-PRS (88) 42. Strasbourg, France.
- GROOMBRIDGE, B., AND R. LUXMOORE. 1989. The green turtle and hawksbill (Reptilia: Cheloniidae): World status, exploitation and trade. CITES Secretariat, Lausanne, Switzerland.
- HEDGEPTH, J. W. 1954. An introduction to the zoogeography of the northern Gulf of Mexico with reference to the invertebrate fauna. *Publ. Inst. Mar. Sci. Univ. Texas* 3:111–211.
- HENDRICKSON, J. R. 1958. The green sea turtle, *Chelonia mydas* (Linn.) in Malaya and Sarawak. *Proc. Zool. Soc. London* 130:455–535.
- . 1979. Chemical discrimination of tortoise-shell materials and reptilian leathers. Final report on contract No. 14-16-0002-3701. U.S. Fish and Wildlife Service, Albuquerque, NM USA.
- . 1980. Ecological strategies of sea turtles. *Am. Zool.* 20:597–608.
- KARL, S. A., B. W. BOWEN, AND J. C. AVISE. 1992. Global population structure and male-mediated gene flow in the green turtle (*Chelonia mydas*): RFLP analyses of anonymous nuclear DNA regions. *Genetics* 131:163–173.
- KLINGER, R. C., AND J. A. MUSICK. 1992. Annular growth layers in juvenile loggerhead turtles (*Caretta caretta*). *Bull. Mar. Sci.* In press.
- LANSMAN, R. A., R. O. SHADE, J. F. SHAPIRA, AND J. C. AVISE. 1981. The use of restriction endonucleases to measure mitochondrial DNA sequence relatedness in natural populations. III. Techniques and potential applications. *J. Mol. Evol.* 17:214–226.
- LEBEAU, A. 1985. Breeding evaluation trials in the green turtle *Chelonia mydas* (Linne) on Scilly Atoll (Leeward Islands, French Polynesia) during the breeding seasons 1982–1983 and 1983–1984. *Proc. Fifth International Coral Reef Congress, Tahiti*. Vol. 2 (abstract only).
- LIMPUS, C. J. 1982. The status of Australian sea turtle populations, pp. 297–303. In K. A. Bjorndal (ed.), *Biology and Conservation of Sea Turtles*. Smithsonian Institution Press, Wash., DC USA.
- . 1987. A turtle fossil on Raine Island, Great Barrier Reef. *Search* 18:254–256.
- LIMPUS, C. J., V. BAKER, AND J. D. MILLER. 1979. Movement induced mortality of loggerhead eggs. *Herpetologica* 35:335–338.
- LIMPUS, C. J., J. D. MILLER, C. J. PARMENTER, D. REIMER, N. MCLACHLAND, AND R. WEBB. 1992. Migration of green (*Chelonia mydas*) and loggerhead (*Caretta caretta*) turtles to and from eastern Australian rookeries. *Wildl. Res.* In press.
- LIMPUS, C. J., AND P. C. REED. 1985. The green turtle *Chelonia mydas* in Queensland: Population structure in a coral reef feeding ground, pp. 343–351. In G. C. Grigg, R. Shine, and H. Ehmann (eds.), *Biology of Australasian Frogs and Reptiles*. Surrey Beatty and Sons, Sydney, Australia.
- LIMPUS, C. J., AND D. G. WALTER. 1980. The growth of immature green turtles (*Chelonia mydas*) under natural conditions. *Herpetologica* 36:162–165.
- LUNDELIUS, E. L., JR. 1987. The North American quaternary sequence, pp. 211–235. In M. O. Woodburne (ed.), *Cenozoic Mammals of North America*. University of California Press, Berkeley, CA USA.
- MEYER, A., T. D. KOCHER, P. BASASIBWAKI, AND A. C. WILSON. 1990. Monophyletic origin of Lake Victoria cichlid fishes suggested by mitochondrial DNA sequences. *Nature* 347:550–553.
- MEYLAN, A. B. 1982. Sea turtle migration—evidence from tag returns, pp. 91–100. In K. A. Bjorndal (ed.), *Biology and Conservation of Sea Turtles*. Smithsonian Institution Press, Wash., DC USA.
- MEYLAN, A. B., B. W. BOWEN, AND J. C. AVISE. 1990. A genetic test of the natal homing versus social facilitation models for green turtle migration. *Science* 248:724–727.
- MOLL, D. 1983. A proposed origin of nesting location divergence and a shared feeding range in Brazilian green turtle populations. *Copeia* 1983:121–125.
- MORTIMER, J. A., AND A. CARR. 1987. Reproduction and migration of the Ascension Island green turtle (*Chelonia mydas*). *Copeia* 1987:103–113.
- MROSOVSKY, N. 1983. *Conserving Sea Turtles*. British Herpetological Society, London, UK.
- NEI, M. 1987. *Molecular Evolutionary Genetics*. Columbia University Press, N.Y., USA.
- NEI, M., AND W.-H. LI. 1979. Mathematical models for studying genetic variation in terms of restriction endonucleases. *Proc. Nat. Acad. Sci. USA* 76:5269–5273.
- NEI, M., AND F. TAJIMA. 1981. DNA polymorphism detectable by restriction endonucleases. *Genetics* 97:145–163.
- NEIGEL, J. E., AND J. C. AVISE. 1986. Phylogenetic relationships of mitochondrial DNA under various demographic models of speciation, pp. 513–534. In E. Nevo and S. Karlin (eds.), *Evolutionary Processes and Theory*. Academic Press, N.Y., USA.
- OWENS, D. W., M. A. GRASSMAN, AND J. R. HENDRICKSON. 1982. The imprinting hypothesis and sea turtle reproduction. *Herpetologica* 38:124–135.
- PAMILO, L., AND M. NEI. 1988. Relationships between gene trees and species trees. *Mol. Biol. Evol.* 5:568–583.
- PARSONS, J. 1962. *The Green Turtle and Man*. University of Florida Press, Gainesville, FL USA.
- PRITCHARD, P. C. H. 1971. Galápagos sea turtles—preliminary findings. *J. Herpetol.* 5:1–9.
- . 1976. Post-nesting movements of marine turtles (Cheloniidae and Dermochelyidae) tagged in the Guianas. *Copeia* 1976:749–754.

- . 1979. *Encyclopedia of Turtles*. T.F.H. Publications, Neptune, NJ USA.
- . 1980. The conservation of sea turtles: Practices and problems. *Am. Zool.* 20:609–617.
- . 1982. Marine turtles of the South Pacific, pp. 253–262. *In* K. A. Bjorndal (ed.), *Biology and Conservation of Sea Turtles*. Smithsonian Institution Press, Wash., DC USA.
- PRITCHARD, P. C. H., AND P. TREBBAU. 1984. The Turtles of Venezuela. *Contrib. Herpetol.* 2, Society for the Study of Amphibians and Reptiles. Fundacion de Internados Rurales, Caracas, Venezuela.
- RHODIN, A. G. J. 1985. Comparative chondro-osseous development and growth of marine turtles. *Copeia* 1985:752–771.
- ROSS, J. P. 1985. Biology of the green turtle, *Chelonia mydas*, on an Arabian feeding ground. *J. Herpetol.* 19:459–468.
- ROSS, J. P., AND M. A. BARWANI. 1982. Review of sea turtles in the Arabian area, pp. 373–383. *In* K. A. Bjorndal (ed.), *Biology and Conservation of Sea Turtles*. Smithsonian Institution Press, Wash., DC USA.
- SCHULZ, J. P. 1982. Status of sea turtle populations nesting in Suriname with notes on sea turtles nesting in Guyana and French Guiana, pp. 435–437. *In* K. A. Bjorndal (ed.), *Biology and Conservation of Sea Turtles*. Smithsonian Institution Press, Wash., DC USA.
- SLATKIN, M. 1985. Rare alleles as indicators of gene flow. *Evolution* 39:53–65.
- . 1987. Gene flow and the geographic structure of natural populations. *Science* 236:787–792.
- . 1989. Detecting small amounts of gene flow from the phylogeny of alleles. *Genetics* 121:609–612.
- SLATKIN, M., AND N. H. BARTON. 1989. A comparison of three indirect methods for estimating average levels of gene flow. *Evolution* 43:1349–1368.
- SLATKIN, M., AND W. P. MADDISON. 1989. A cladistic measure of gene flow inferred from the phylogeny of alleles. *Genetics* 123:603–613.
- SNEATH, P. H. A., AND R. R. SOKAL. 1973. *Numerical Taxonomy*. W. H. Freeman and Co., San Francisco, CA USA.
- SOKAL, R. R., AND F. J. ROHLF. 1981. *Biometry* (Second ed.). W.H. Freeman and Co., San Francisco, CA USA.
- SOLE, G., AND G. MEDINA. 1989. The green turtles of Aves Island, pp. 171–173. *In* S. A. Eckert, K. A. Eckert, and T. H. Richardson (Compilers), *Proceedings of the Ninth Annual Workshop on Sea Turtle Conservation and Biology*. NOAA Tech. Memo. NMFS-SEFC-232.
- SUGANUMA, H. 1985. Green turtle research program in Ogasawara. *Marine Turtle Newsletter* 33:2–3.
- SWOFFORD, D. L. 1990. PAUP: Phylogeny analysis using parsimony, version 3.0. Illinois Natural History Survey, Champaign, IL USA.
- SWOFFORD, D. L., AND G. L. OLSEN. 1990. Phylogeny reconstruction, pp. 411–501. *In* D. M. Hillis and C. Moritz (eds.), *Molecular Systematics*. Sinauer, Sunderland, MA USA.
- TAKAHATA, N., AND S. R. PALUMBI. 1985. Extranuclear differentiation and gene flow in the finite island model. *Genetics* 109:441–457.
- WILSON, A. C., R. L. CANN, S. M. CARR, M. GEORGE, JR., U. B. GYLLENSTEN, K. M. HELM-BYCHOWSKI, R. G. HIGUCHI, S. R. PALUMBI, E. M. PRAGER, R. D. SAGE, AND M. STONEKING. 1985. Mitochondrial DNA and two perspectives on evolutionary genetics. *Biol. J. Linn. Soc.* 26:375–400.
- ZUG, G. R., AND G. H. BALAZS. 1985. Skeletochronological age estimates for Hawaiian green turtles. *Marine Turtle Newsletter* 33:9–10.
- ZUG, G. R., A. H. WYNN, AND C. RUCKDESCHEL. 1986. Age determination of loggerhead sea turtles, *Caretta caretta*, by incremental growth marks in the skeleton. *Smithson. Contrib. Zool.* 427:1–34.

Corresponding Editor: M. Miyamoto