

UC Irvine

UC Irvine Previously Published Works

Title

Inhalation exposure of animals

Permalink

<https://escholarship.org/uc/item/52t1j4fb>

Journal

Environmental Health Perspectives, 16

ISSN

0091-6765

Author

Phalen, R F

Publication Date

1976-08-01

DOI

10.2307/3428580

Copyright Information

This work is made available under the terms of a Creative Commons Attribution License, available at <https://creativecommons.org/licenses/by/4.0/>

Peer reviewed

Inhalation Exposure of Animals

by Robert F. Phalen*

Relative advantages and disadvantages and important design criteria for various inhalation exposure methods are presented. Five types of exposures are discussed: whole-body chambers, head-only exposures, nose or mouth-only methods, lung-only exposures, and partial-lung exposures. Design considerations covered include: air cleaning and conditioning; construction materials; losses of exposure materials; evenness of exposure; sampling biases; animal observation and care; noise and vibration control, safe exhausts, chamber loading, reliability, pressure fluctuations; neck seals, masks, animal restraint methods; and animal comfort. Ethical considerations in use of animals in inhalation experiments are also discussed.

Introduction

Emphasis here is placed on design considerations of systems for controlled delivery of airborne materials including particulates. Operational procedures, generation of exposure atmospheres, sampling and characterization methodology are only briefly mentioned. The organization is by mode of exposure, including immersion of whole animals in chambers, exposures of the head only, exposures of the nose or mouth only, lung only and partial lung only exposures. Each of these modes of exposure has its own advantages, disadvantages, areas of application, and special design requirements. The objectives of a particular toxicologic investigation will determine the exposure method of choice.

The primary purpose of an inhalation exposure system for live animals is to provide a controlled, characterized delivery of airborne material to the respiratory system. Duration of exposures range through single acute exposures lasting minutes, to repeated and continuous exposures lasting months or perhaps years. Exposure may be to airborne material in physical states ranging from subatomic (ions, for example) to complex mixtures of gases and particulates, both solid and

liquid. In most inhalation studies it is desirable to eliminate or limit exposure through skin, eyes, contaminated food, or other nonrespiratory pathways.

Exposure systems tend to become more complex when used for longer-term exposures, especially when they must also serve as housing for animals. Criteria for animal housing are set forth in the *Guide for the Care and Use of Laboratory Animals*, published and updated periodically by the U.S. Department of Health, Education and Welfare (1). The air supply to any exposure system should be clean, except for intentional materials, maintained at comfortable temperature, relative humidity and air velocity, and should not contain excessive amounts of waste products including ammonia and carbon dioxide. For conscious animals the exposure environment should be humane with respect to noise, vibration, lighting, and freedom of movement. Environmental stresses tend to modify the response of the animal subject. In short, unintentional stresses should be eliminated or at least minimized. Anesthetized animals may require special physiologic support with respect to lung ventilation, maintenance of body temperature and humidification in the respiratory tract.

Control and characterization of the exposure atmosphere implies accurate monitoring and sampling in the breathing zone, either continuously or frequently enough to define the ex-

*Department of Community and Environmental Medicine, College of Medicine, University of California, Irvine, California 92664.

posure history. Determination of actual dose to the animal usually necessitates direct assay of exposed tissues; the simple product of airborne concentration and duration of exposure is seldom adequate, especially when airborne particulates are present. The problems in aerosol characterization are formidable enough to recommend the introductory works by Mercer (2) and by Silverman, Billings, and First (3).

Background

A multitude of published works exist in which various inhalation exposure systems are described. Those cited here are only a sample of the available works. Several works contain reviews or general discussions of inhalation exposure systems (4-9); that by Frazer et al. (8) provides an extensive review of chambers.

Chambers

Modern exposure chambers are usually of the dynamic type in that a continuous flow of air is maintained during operation. The hexagonal (in cross section) University of Rochester chamber described by Leach et al. (10), still widely used, has a history of over 25 years in aerosol inhalation studies. One version (1.3 m³ volume) with tapering top and bottom sections was designed for simultaneous exposure of four monkeys, eight dogs, and 40 rats to radioactive aerosols. A similar chamber with rectangular crosssection (1.3 m³ volume) is described by Hinners, Burkart, and Conter (5) and by Laskin, Kushner, and Drew (11). Large, dome-shaped chambers (12 ft in diameter, 8 ft high) capable of operation at reduced pressures and suitable for lifetime housing of a variety of animals are described by A. A. Thomas (12). Long-term (165 day) continuous housing of monkeys, dogs, rats, and mice in the chambers reportedly had no significant effects on growth, organ weights or a variety of blood chemistry/hematology determinations (13). Spherical chambers (6 ft in diameter) for exposure of large numbers of small animals (100 hamsters) are described by Stuart (14). The chambers described above all have specially-designed cages for holding experimental animals.

Head-Only Exposures

Head-only exposure systems are typified by those described by Stuart (14) for dogs, by Kirk, Rehnberg, and Morken (15), and by R. G. Thomas (16) for rodents. Scheimberg (17) mentions a small individual helmet exposure chamber worn

by monkeys during exposures to aerosols. In all of the above systems animals are physically restrained or anesthetized.

Nose/Mouth-Only Exposures

Inhalation exposures limited to either the nose or oral cavity are usually accomplished by using masks, catheters in the nose, or individual tubular containers with one end open to the exposure atmosphere. Mask-type exposure, usually limited to relatively large animals, for dogs is described by Bair et al. (18), Boecker, Aguilar, and Mercer (19), Cuddihy and Boecker (20), Frank and Speizer (21), and Poynter and Spurling (22). Masks used for pulmonary function testing but suitable for inhalation exposures are described for dogs by Dubin and Morrison (23) and for ponies by Mauderly (24). Nasal tubes for inhalation exposure of donkeys are described by Albert et al. (25). Battista (26) discusses a mask used on the chicken. Restraint of masked, unanesthetized large animals is typically by sling (19) or stocks (27).

Tubular holders and delivery systems for nose-only exposure of rodents are described by Rabbe et al. (28) and Smith and Spurling (7). Perforated metal holders for small rodents, as described by Brar et al. (29), can reduce the stress due to build-up of body temperature during exposure. Mauderly and Tesarek (30) describe alterations in pulmonary function induced by the restraining devices used in inhalation exposures.

Lung-Only Exposures

Exposure via direct inhalation through intratracheal tubes is reported by Phalen and Morrow (31) and by Auerbach et al. (32). Battista et al. (26) describe a dual-lumen tube, allowing separation of inspired and expired air, having very small dead space, that is passed through a chronic tracheostomy.

Insufflation of aerosol directly into the lung through intratracheal catheters was used by Bianco et al. (33) in studies with radioactive tantalum aerosol. Pulsed insufflation from a compressed-air dust elutriator was in synchrony with spontaneous inspirations.

A technique for performing chronic tracheostomies in laboratory animals is described by Thilenius and Vial (34), but an undesirable effect of tracheostomy in dogs, viz., altered brain temperature, is reported by Baker, Chapman, and Nathason (35).

Characteristics of Various Modes of Exposure

Each of the common modes of exposure by inhalation has its own advantages, disadvantages and special design requirements. Table 1 is presented as an aid to comparison of modes of exposure. It must be said that whether or not a particular feature is considered to be an "advantage" or a "disadvantage" depends on what one is trying to do. For example, the entry of exposure material through multiple pathways as occurs in chambers is listed as a disadvantage; it may ob-

viously be an advantage in certain types of investigation.

Chambers

A typical dynamic chamber with some of the supporting components is shown schematically in Figure 1. Advantages of this type of exposure system include: adaptability to a large variety and large numbers of animals exposed either simultaneously or separately; capability for housing animals for long periods under exposure conditions; lack of restraint or anesthesia during exposure, and; the existence of a relatively large

Table 1. Comparative evaluation of inhalation exposure methods and some design considerations associated with each method.

Mode of exposure	Advantages	Disadvantages	Design considerations
Chambers (whole-body)	Variety and number of animals Chronic studies Minimum restraint Large data base Controllable environment Impressive	Messy Multiple routes of exposure: skin, eyes, oral (food, water) Variability of dose Can not pulse exposure easily Inefficient Poor contact between animals and investigators Expensive	Clean air (5,36,37) Inert materials (8,9) Losses (8,9) Even distribution in space and time (5,9,10) Sampling (2,3) Animal care (1,5) Observation (9,10) Noise, vibration, humidity Air temperature (1,5,8,37) Safe exhaust Loading (8,9) Reliability
Head only	Good for repeated exposure Limited routes of entry into animal More efficient dose delivery	Stress to animal Losses can be large Seal around neck Labor in loading/unloading	Even distribution Pressure fluctuations Sampling and losses Air temperature, humidity Animal comfort (15,16) Animal restraint (19,27)
Nose/mouth only	Exposure limited to mouth and respiratory tract Uses less material (efficient) Containment of material Can pulse the exposure	Stress to animal Seal about face Effort to expose large number of animals	Pressure fluctuations Body temperature Sampling Seals Animal comfort Losses in plumbing/masks
Lung only	Precision of dose One route of exposure Uses less material (efficient) Can pulse the exposure	Technically difficult Anesthesia or tracheostomy Limited to small numbers Bypasses nose Artifacts in deposition and response Technically more difficult	Air humidity/temperature Stress to the animal Physiologic support
Partial lung	Precision of total dose Localization of dose Can achieve very high local doses Unexposed control tissue from same animal	Anesthesia Placement of dose Difficulty in interpretation of results Technically difficult Possible redistribution of material within lung	Stress to animal Physiologic support

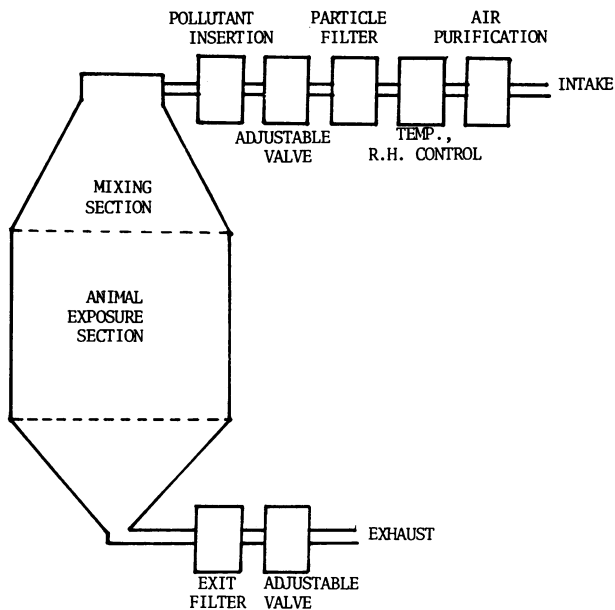

FIGURE 1. Chamber exposure system for inhalation exposure via whole-body immersion (Rochester type).

data base for this type of exposure. Chambers can be sealed and are thus appropriate for use with very toxic materials and for exposures under conditions of nonambient pressures, temperatures and humidities. Inhalation chambers are definitely the method of choice in many cases. Large chambers also photograph well, demonstrate a high level of commitment of the laboratory, and appear to greatly impress visitors to the laboratory.

Several disadvantages are associated with inhalation exposure chambers. The exposure is messy; airborne material enters totally immersed animals through skin, mouth and eyes, covers fur, food, caging, and anything else present. The dose received by animals in chambers is often highly variable. Animals tend to avoid exposure by huddling together, covering their noses with their own fur, or burying their noses in corners of cages. The level of exposure does not stabilize quickly, nor can the level always be varied sharply in large chambers operating at typical flow rates. Stabilization of proper exposure levels may require an hour or more (5), and the effects of adjustments made on generating equipment are not seen immediately. Automatic feedback control of generators, air-conditioners and motors may produce cycling of the level of exposure. Also, large volumes of air may be required in dynamic chambers, resulting in a waste of exposure material and often great expense in air-conditioning the

main through-put air. Chambers can be quite wasteful and inefficient. Animals in chambers are somewhat remote. It is difficult to be aware of their condition or to monitor physiologic parameters. The cost of chambers is relatively high, especially since they are usually constructed of fairly inert materials such as stainless steel, special alloys of metals, glass, and thermoplastics.

Considerations that should enter into the design of inhalation chambers include the following. Preconditioning of air with regulation of temperature, humidity, and level of unwanted contaminants must be considered. An introduction to this topic is given by Nelson (36), and an engineering report by Dennison (37) describes design details.

Inert materials that do not significantly change, deplete or augment the desired atmospheres must be chosen (8). It may be convenient to provide for covering the walls of a chamber with disposable stainless steel foil or another protective material.

Losses to chamber surfaces, especially of particulate materials, can be a severe problem. Losses can be diminished by use of large volume chambers, nonturbulent air flows, and electrically conductive interior surfaces. Nonmetallic surfaces are notorious for acquiring local regions of high charge that scavenge particles due to electrostatic forces. An unlucky designer may inadvertently end up with an unwanted, oversized electrostatic precipitator.

Spatial uniformity of airborne materials is usually achieved by fitting the chamber with cone- or pyramid-shaped entry and exit sections (5,8-10). Uniformity is also achieved by proper injection and mixing of materials into the chamber air. Venturi sections and mixing chambers may be necessary (10). Systematic rotation of cages during exposure may be desirable. Temporal uniformity of exposure requires not only stable generators and airflow systems but also chamber construction materials that do not change their reactivity with time during exposure. Acrylic, for example, has variable reactivity to ozone over a period of hours at moderate airborne levels.

Samples for characterization of the exposure atmosphere should be taken from the breathing zone of animal subjects and be taken through lines that do not compromise the sample. Design of movable, largebore metallic sampling tubes is advisable. Samples must be taken during the actual exposures, as the presence of animals may greatly reduce the concentrations present. Sam-

pling is a serious problem, and there are many published reports stating no-effect that makes one seriously question the sampling methods.

Provision for animal care and observation should be considered in chamber design. Internal flushing, watering and feeding systems must be carefully designed to prevent accumulation of exposure materials and animal wastes on their surfaces. Large chambers may be provided with airlock type entries so that continuous exposure can be maintained (8,9,12). Observation windows should be limited in size to prevent the undesirable effects of static charge buildup.

Attention should be directed to control of environmental noise and vibration as well as temperature and humidity. Valves and motors are sources of noise that can be reduced by placing soft, in-line air filters between them and the chamber. Motors attached to chamber surfaces by hard mounts can cause excessive vibration. If possible, scientific personnel should enter the chamber during operation and remain there long enough to notice any potentially undesirable environmental stresses before animals are exposed inside the chamber.

A safe exhaust system is important, especially when toxic, explosive, or otherwise offensive atmospheres are investigated. This may involve addition of prefilters, high-efficiency filters, electrostatic precipitators, wet scrubbers, or even collection of all of the throughput.

Animal loading limits are based upon consideration of reactivity of animal surfaces with the exposure atmosphere and generation of heat and water vapor by the animals. Experience indicates that no more than 5% of the chamber volume should be occupied by animals (8,9).

System reliability involves consideration of failure of critical components, ease of routine maintenance, and replacement of finite lived components such as filters and seals. Filters can be continuously monitored for pressure drop during chamber operation and replaced when they become excessively occluded.

Many other considerations enter into the design of chambers, including animal placement, compatibility of species, caging design, placement of generators, etc. Original designs should be drawn with great care and hopefully with the help of persons having practical experience in animal-chamber operation.

Head-Only Exposures

An example of a head-only exposure system is depicted in Figure 2. Primary advantages of this

type of exposure include applicability to repeated brief exposures and some limitation in the number of possible pathways of entry of material into the animal. It is usually difficult, if not impossible, for the animal to avoid inhalation exposure in the head-only system. The head or neck region of the animal is usually firmly restrained and resultant stress to the animal may be significant. Other disadvantages include losses of material to the fur of the head (especially if fur becomes electrically charged), difficulty in achieving a good neck seal without interfering with blood flow or ventilation, and the additional difficulty and time required in handling, loading and unloading of animals.

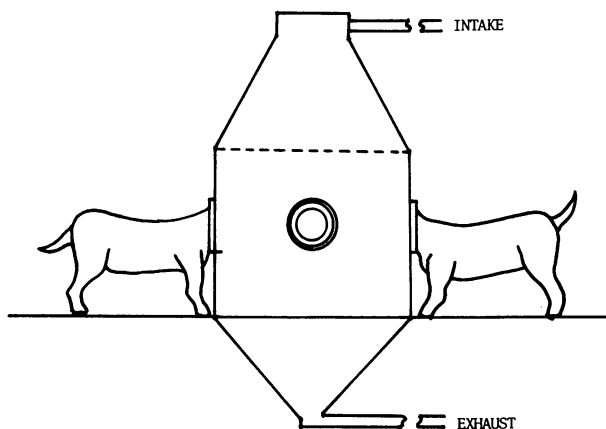

FIGURE 2. Head-only inhalation exposure system.

Design considerations for head-only exposure systems include the following. Uniformity of exposure from one animal to another may be achieved by maintaining adequate dispersion and a large through-put of air to prevent animals from breathing in a depleted atmosphere. When the head-only exposure is from a chamber, distribution of material in the chamber must be uniform. Helmet exposures may also require large air flows to prevent condensation of expired water vapor, buildup of expired products or depletion of the exposure atmosphere. As animals inhale and exhale, large pressure fluctuations may occur in the system. Raabe has recently described (38) placement of a spirometer in parallel with the animal that may reduce these fluctuations and also provide a record of the breathing pattern during exposure. As in chamber exposures, losses and sampling of the exposure atmosphere must be carefully considered to insure adequate definition of the exposure. Environmental considerations include proper air temperature and

humidity, level of carbon dioxide, and control of noise and vibration. Physical comfort of the animal requires a tolerable seal around the neck. Two systems in use are inflatable collars (15,16) and thin rubber membranes having a small hole that stretches to accommodate the neck. The seal must be soft and conform to the noncircular crosssection of the neck. A wide, soft support beneath the neck may be necessary to prevent choking the animal.

During exposure of unanesthetized animals, restraint additional to that about the neck may be necessary. As previously mentioned (19,27), comfortable slings and padded stocks may be useful. A struggling, restrained animal may rapidly develop very high body temperature, and anesthesia or sedation should be considered.

Nose/Mouth Only Exposures

Exposure of rats in tubes and a dog via a mask attached to a dynamic chamber is depicted in Figure 3. Animals may breathe from chambers, large conduits, smaller supply tubes, or directly from a generator (a lighted cigarette, for example). Such exposures largely limit the initial entry of materials to the respiratory tract and oral cavity (possible eye irritation is thus eliminated), less exposure material need be generated per animal, containment of material within the exposure apparatus is straightforward and the level of concentration of the exposure material may be rapidly changed. This type of exposure can also involve considerable stress due to close confinement. Getting good seals around the face and extra handling of subjects are other disadvantages.

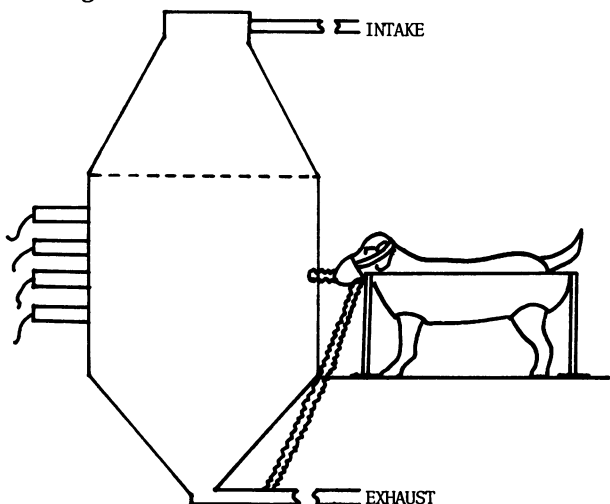

FIGURE 3. Nose-only inhalation exposure of rats in tubes and dog in sling.

General design considerations are similar to those of the head-only systems. Mask design presents some additional special problems. Masks should be comfortable, seal tightly and allow for collection or drainage of saliva. Successful masks or nasal tubes are usually carefully handmade and the literature contains some useful designs and descriptions (18,23-26). Inhalation exposure masks may also be used for pulmonary function testing provided the seal is good and the dead-space is reasonably small. Perforated metal tubes that conduct away body heat and permit direct ventilation of the animal can be used for holding animals. Glass, plastic, and even solid metal tubular enclosures can lead to excessive body heating within minutes.

Lung-Only Exposures

The lung may be directly exposed through conventional intratracheal tubes or via tracheostomies (26,31,32). Tubes placed into the trachea require either anesthesia or prior surgical preparation of the subject, neither method being very popular in small animals.

These exposures allow delivery by inhalation of relatively precise, controlled doses, with the exposure limited to the lung. The nose is bypassed, which sometimes is an advantage but at the same time jeopardizes extrapolation to more natural-type exposure. Delivery is very efficient, in that very little excess material need be generated and pulsed exposures are easily performed.

Major problems include various technical difficulties of procedure that make exposure of large numbers of animals time-consuming. Artifacts associated with this type of exposure include effects of anesthesia or surgical intervention, drying of the trachea, and possible abnormal deposition patterns in the lung or impairment of ventilation caused by in-dwelling tubing.

Special considerations include precise control of temperature and humidity of inhaled air, stress to the animal, and the possible necessity of physiologic support in maintaining proper ventilation and body temperature.

Partial Lung Exposures

Typically, insufflations of airborne materials and instillations of materials in liquids are used to expose subunits of the lung. A catheter may be placed into a lobe or other subunit and airborne material passed through in a steady stream or in puffs synchronized with breathing (33). The total

dose can be very precisely controlled, localized to a specific region, and administered at local levels that would be lethal if issued to a larger target. For example, one lobe may be exposed and other lobes used more-or-less as controls.

Problems occur in the need for general anesthesia, precise placement of catheters and difficulty in extrapolation of results. This type of exposure is perhaps the most difficult technically, and considerable effort must be expended on each animal in order to get meaningful results. Additionally, nonphysiological redistribution of material within the lung may occur after initial placement.

In designing such experiments, the more critical considerations include physiologic support of the subject, including maintenance of anesthesia and proper ventilation. The concentration, pH, temperature, and irritant nature of the exposure material must be taken into consideration, as unwanted, severe tissue damage may otherwise occur.

Discussion

Controlled exposure of animals by inhalation is never a trivial endeavor. No single exposure device, no matter how sophisticated, can serve all purposes. Chambers are almost essential for continuous exposures and can also be used to mix, hold and supply materials for exposure of animals outside the chamber. Other modes of exposure—head-only, nose/mouth-only, lung-only, and partial-lung—require specially designed, often handmade, devices as well as personnel well-trained in animal handling and physiology.

A few words about the ethics involved in inhalation exposures are in order. In an inhalation experiment, the subject is often critically dependent on the exposure system for delivery of a breathable atmosphere in a comfortable environment. Animals can be placed in situations of high CO₂, extremes in humidity and temperature of the air, or cruel confinement without the knowledge of the investigator. For example, improperly fitted collars, slings, and other restraint devices can cause considerable discomfort. Padding should be used liberally and sedation or anesthesia considered in many cases. Horses, donkeys, ponies, pigs, and possibly other animals seem to require some freedom of movement of the head when restrained in an unanesthetized state for more than brief periods. Animals can overheat within minutes in close-fitting body enclosures unless provision is made for cooling. Ethical

experimentation and proper scientific procedure require that the investigator have intimate knowledge of stresses placed on the animal. All too often this is not the case. Similarly, reliability of procedures and critical mechanical components can have ethical ramifications. I recall one animal, fortunately anesthetized at the time, being given about 15 successive forced inhalations while an exhalation valve was inadvertently left in a closed position. The life of this valuable animal could have been spared by use of a pressure relief valve or even pressure gauge in the exhalation line.

Training of animals, or at least putting them through a few short trial sham exposures, can help them to relax and thus improve their performance during actual exposures as well as improve the quality of resultant data.

This work was supported by the California Resources Board under contract No. ARB 5-725.

REFERENCES

1. Guide for the Care and Use of Laboratory Animals. U.S. Department of Health, Education and Welfare, Public Health Service, National Institutes of Health. DHEW Publication Number (NIH) 74-23 (1974).
2. Mercer, T. T. *Aerosol Technology in Hazard Evaluation*. Academic Press, New York, 1973.
3. Silverman, L., Billings, C. E., and First, M. W. *Particle Size Analysis in Industrial Hygiene*. Academic Press, New York (1971).
4. Battista, S. P., et al. A new system for quantitatively exposing laboratory animals by direct inhalation. *Arch. Environ. Health* 27: 376 (1973).
5. Hinners, R. G., Burkart, J. K., and Contner, G. L. Animal exposure chambers in air pollution studies. *Arch. Environ. Health* 13: 609 (1966).
6. Hoffmann, D., and Wynder, E. L. Chamber development and aerosol dispersion. In: *Inhalation Carcinogenesis*. M. G. Hanna, Jr., P. Nettesheim, and J. R. Gilbert, Eds., U.S. Atomic Energy Commission, Oak Ridge, 1970.
7. Smith, S. W., and Sparling, N. W. Device for exposing the respiratory tract of the rat to medicinal aerosols. *Lab. Practice* 23: 717 (1974).
8. Frazer, D. A., et al. *Exposure Chambers for Research in Animal Inhalation*. (Public Health Monograph No. 57). U.S. Department of Health, Education and Welfare, U.S. Government Printing Office, Washington, D.C. 1959.
9. Lippmann, M. Experimental inhalation studies—equipment and procedures. In: *Inhalation Carcinogenesis*. M. G. Hanna, P. Nettesheim, and J. R. Gilbert, Eds., U.S. Atomic Energy Commission, Oak Ridge, 1970.
10. Leach, L. J., et al. *A Multiple Chamber Exposure Unit Designed for Chronic Inhalation Studies*. University of Rochester Report UR-534, Rochester, N.Y. 1958.
11. Laskin, S., Kushner, M., and Drew, R. T. Studies in pulmonary carcinogenesis. In: *Inhalation Carcinogenesis*. M. G. Hanna, Jr., P. Nettesheim, and J. R. Gilbert, Eds., U.S. Atomic Energy Commission, Oak Ridge, 1970.
12. Thomas, A. A. Chamber equipment design considerations

- for altitude exposures. In: Proceedings of the Conference on Atmospheric Contamination in Confined Spaces. Aerospace Medical Research Laboratories, Wright-Patterson Air Force Base, Ohio, TR-65-230, 1965.
13. Egan, G. E., and Fogle, G. L. A comparison of experimental control animals housed in altitude chambers and animal rooms. In: Proceedings of the Fourth Annual Conference on Atmospheric Contamination in Confined Spaces. Aerospace Medical Research Laboratories, Wright-Patterson Air Force Base, Ohio, AMRL-TR-68-175, 1965.
 14. Stuart, B. O., Willard, D. H., and Howard, E. B. Studies of inhaled radon daughters, uranium ore dust, diesel exhaust and cigarette smoke in dogs and hamsters. In: *Inhaled Particles. III.* W. H. Walton, Ed., Unwin Brothers Ltd., Surrey, England, 1971.
 15. Kirk, W. P., Rehnberg, B. F., and Morken, D. A. Acute lethality in guinea pigs following respiratory exposure to ⁸⁵Kr. *Health Physics* 28: 275 (1975).
 16. Thomas, R. G., and Lie, R. Procedures and equipment used in inhalation studies on small animals. U.S. Atomic Energy Commission Research and Development Report, Lovelace Foundation Report No. LF-11, Albuquerque, N.M., 1963.
 17. Scheimberg, J. Inhalation of a powdered aerosol medication by non-human primates in individual space-type exposure helmets (abstract). *Toxicol. Appl. Pharmacol.* 25: 478 (1973).
 18. Bair, W. J., et al. Apparatus for direct inhalation of cigarette smoke by dogs. *J. Appl. Physiol.* 26: 847 (1969).
 19. Boecker, B. B., Aguilar, F. L., and Mercer, T. T. A canine inhalation exposure apparatus utilizing a whole-body plethysmograph. *Health Physics* 10: 1077 (1964).
 20. Cuddihy, R. G., and Boecker, B. B. Controlled administration of respiratory tract burdens of inhaled radioactive aerosols in beagle dogs. *Toxicol. Appl. Pharmacol.* 25: 597 (1973).
 21. Frank, N. R., and Speizer, F. E. SO₂ effects on the respiratory system in dogs. *Arch. Environ. Health* 11: 624 (1965).
 22. Poynter, D., and Spurling, N. W. Some cardiac effects of beta-adrenergic stimulants in animals. *Postgrad. Med. J., Suppl.* 47: 21 (1971).
 23. Dubin, S., and Morrison, G. A face mask and mouthpiece for respiratory studies in unanesthetized beagle dogs. *J. Appl. Physiol.* 27: 104 (1969).
 24. Mauderly, J. L. Evaluation of the grade pony as a pulmonary function model. *Amer. J. Vet. Res.* 35: 1025 (1974).
 25. Albert, R. E., et al. Effects of cigarette smoke components on bronchial clearance in the donkey. *Arch. Environ. Health* 29: 96 (1974).
 26. Battista, S. P., et al. A new system for quantitatively exposing laboratory animals by direct inhalation. *Arch. Environ. Health* 27: 376 (1973).
 27. Mauderly, J. L., Nenzo, W. C., and Morrison, G. A. Stocks for holding unanesthetized dogs in the standing position. *Lab. Anim. Sci.* 21: 263 (1971).
 28. Raabe, O. G. An improved apparatus for acute inhalation exposure of rodents to radioactive aerosols. *Toxicol. Appl. Pharmacol.* 26: 264 (1973).
 29. Brar, B. S., et al. A laboratory aerosol system for conducting inhalation toxicity studies. Paper presented at 14th Annual Meeting, Society of Toxicology, Williamsburg, Pa., March 1975.
 30. Mauderly, J. L., and Tesarek, J. E. Effects of current aerosol exposure methods on the pulmonary function of beagle dogs and Syrian hamsters. In: *Inhalation Toxicology Research Institute Annual Report 1972-1973.* R. O. McClellan, Ed., LF-46, Lovelace Foundation, Albuquerque, N.M., 1973.
 31. Phalen, R. F., and Morrow, P. E. Experimental inhalation of metallic silver. *Health Physics*, 24: 409 (1973).
 32. Auerbach, O. et al. Effects of cigarette smoking on dogs. *Arch. Environ. Health* 21: 754 (1970).
 33. Bianco, A., et al. Studies of tantalum dust in the lungs. *Radiol.* 112: 549 (1974).
 34. Thilenius, O. G., and Vial, C. B. Chronic tracheostomy in dogs. *J. Appl. Physiol.* 18: 439 (1963).
 35. Baker, M. A., Chapman, L. W., and Nathanson, M. Control of brain temperature in dogs: effects of tracheostomy. *Respir. Physiol.* 22: 325 (1974).
 36. Nelson, G. O. *Controlled Test Atmospheres.* Ann Arbor Science Publishers, Ann Arbor, Mich., 1971.
 37. Dennison, W. J. Design of high flow ambient air purification system. University of California School of Engineering Report UCI-ARTR-75-1, Irvine, Calif. 1975.
 38. Raabe, O. G. New systems for exposure of ponies and beagle dogs to radioactive aerosols. Paper presented at American Industrial Hygiene Association Annual Meeting, Minneapolis, June 1975.