

# UC Irvine

## UC Irvine Previously Published Works

### Title

Genetic Heterogeneity in Tuberous Sclerosis

### Permalink

<https://escholarship.org/uc/item/59m044hb>

### Journal

Annals of the New York Academy of Sciences, 615(1)

### ISSN

0077-8923

### Authors

SMITH, MOYRA  
YOSHIYAMA, K  
WAGNER, C  
[et al.](#)

### Publication Date

1991-04-01

### DOI

10.1111/j.1749-6632.1991.tb37769.x

### Copyright Information

This work is made available under the terms of a Creative Commons Attribution License, available at <https://creativecommons.org/licenses/by/4.0/>

Peer reviewed

# **PDFlib PLOP: PDF Linearization, Optimization, Protection**

**Page inserted by evaluation version  
www.pdflib.com – sales@pdflib.com**

# **Genetic Heterogeneity in Tuberous Sclerosis**

## **Map Position of the TSC2 Locus on Chromosome 11q and Future Prospects<sup>a</sup>**

MOYRA SMITH, K. YOSHIYAMA, C. WAGNER,  
P. FLODMAN, AND B. SMITH

*Department of Pediatrics  
University of California, Irvine  
Irvine, California 92717*

Tuberous sclerosis is a disorder characterized by hamartias and hamartomas expressed in tissues and organs throughout the body. This disorder displays great variation in expression and severity both within and between families.<sup>1</sup> Results of studies indicate that as many as 68% of cases of tuberous sclerosis (TSC) may represent new mutations.<sup>2</sup>

Linkage studies in tuberous sclerosis indicate that a TSC locus maps to chromosome 9q34, but that genetic heterogeneity is likely and that a second TSC locus, TSC2, maps to chromosome 11q.<sup>3-5</sup> The study presented here describes the results of analyses designed to obtain further information on the position of the chromosome 11 TSC locus in families evaluated by us.<sup>6</sup> In addition, we will discuss reported similarities in certain pathologic manifestations in TSC and ataxia telangiectasia. These similarities are of interest in light of the mapping of ataxia telangiectasia to the same region as the TSC locus.<sup>7</sup> We will discuss disorders in which interaction between two separate distant loci was required to produce the phenotype.<sup>8,9</sup> We will consider a hypothesis to explain the lack of penetrance in certain cases of TSC and for the variable manifestations in TSC, and will discuss experimental methodologies to test this hypothesis. Finally, we will discuss plans to further refine the mapping of the TSC locus and elucidate the nature of the underlying genetic defect.

### **MATERIALS AND METHODS**

Included in these analyses are seven families with a total number of 106 individuals, in which analysis of markers on both chromosome 9 and 11 was carried out and in which results of various forms of statistical testing by members of the TSC collaborative group<sup>3-5</sup> indicate that the TSC locus maps to chromosome 11q. These families are Irvine TS 8, 15, 16, 20, 24, 26, and 101. The most clearcut manifestations of tuberous sclerosis occurred in many members in fami-

<sup>a</sup> Funding for this project was provided by grant HD23745 (to M.S.) from the National Institute for Childhood Diseases.

lies 8, 16, 20, 24, 26, and 101. The pedigrees of these families and details of the TSC manifestations are presented in reference 6.

Fifteen markers mapped from 11q14–11q23.1 were used to define the position of the TSC locus. These markers are listed below approximately in order from the most proximal, that is, centromeric, to the most distal: tyrosinase, stromolysin, D11S84, D11S35, CJ52.75, CJ52.5, D11S132, CJ52.77, D11S351, D11S144, D11S29 HBI18P2, PBGD, CJ52.12, and HHH172. References for methods of polymorphism analysis and for chromosomal assignment are listed in refs. 10 and 11. In many instances we derived fragments from these probes that detect the documented RFLPs but are free of repetitive sequence, thus facilitating their use in hybridizations and Southern blot analysis. Fourteen of the fifteen probes represent two allele systems. The probe D11S35 detects a microsatellite polymorphism with seven alleles.<sup>12</sup>

## RESULTS

Examination of the genotypes of markers between tyrosinase and HBI18P2 in the TSC families just listed revealed that families TSC 16, 26, and 101 were most informative in trying to position the TSC gene. The pedigrees of these families and their genotypes are illustrated in FIGURES 1, 2, and 3.

Examination of genotypes in family 16 indicates that two individuals, 16-7 and 16-9, had TSC recombinant with D11S29 and markers distal to this locus (FIG. 1). Examination of genotypes in family 26 (particularly individuals 26-6 and 26-10) places TSC below D11S35. Family TSC 101 was classified as a chromosome 11 family on the basis of the applied artificial chromosome method,<sup>4</sup> but was unclassified on the basis of the maximum lod score or negative lod score method.<sup>3</sup> If this family does represent a chromosome 11 TSC family, results of genotype analysis in individual 5 would place TSC below Cri424 (D11S132) and below CJ52.5. Genotype analysis in individual GS7 would place TSC above CJ52.208/Mct 128.1 (D11S351/D11S144). The distance between markers D11S132 and D11S144 has been estimated to be 10 centimorgans (cM).<sup>13</sup> The distance between D11S144 and CJ52.5 has been estimated to be approximately 5 cM.<sup>11</sup> Analysis in this family would therefore place the TSC2 gene in the 5-cM centimorgan interval between D11S144 and CJ52.5.

## DISCUSSION

Results of linkage analyses of a collaborative dataset by three groups of investigators indicate genetic heterogeneity in tuberous sclerosis and evidence that gene loci on chromosomes 9 and 11 lead to this disorder. Existence of a third locus has not been ruled out.<sup>3-5</sup> In the study presented here we have described analyses carried out with 15 probes on chromosome 11q to define the regional localization of the TSC2 gene. These studies indicate that TSC2 maps below D11S35 and above D11S29.

## FUTURE PROSPECTS

For further progress in the genetic analyses of TSC it will be important to refine the mapping of the TSC1 and TSC2 genes on chromosomes 9 and 11. It will

TS-16

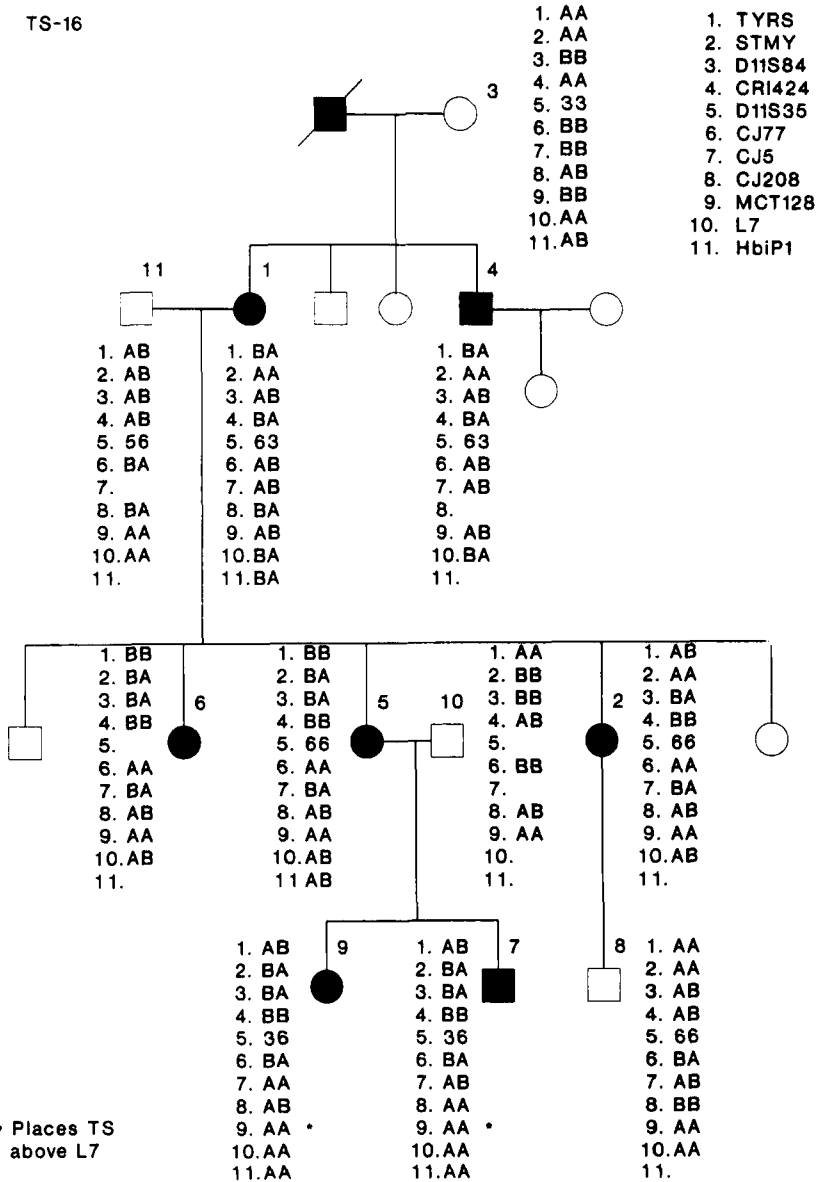

FIGURE 1.

FIGURES 1, 2, and 3. Genotypes for chromosome 11q markers in families TSC 16, 26, and 101. Markers are listed in linear order, according to references 10, 11, and 13. Note, however, that in some cases the exact linear order is not determined with certainty at this time, for example, order of D11S132 (Cri1424) relative to D11S35.

be particularly important to develop additional highly polymorphic probes in these chromosomal regions, for example, the microsatellite repeat type of polymorphisms that have multiple alleles.<sup>12,14</sup> Definitive classification of a particular family as TSC1 or TSC2 will depend on the development of highly informative markers in the 9q34 and 11q22-q23 regions. Further studies are needed to investigate whether there is additional heterogeneity.

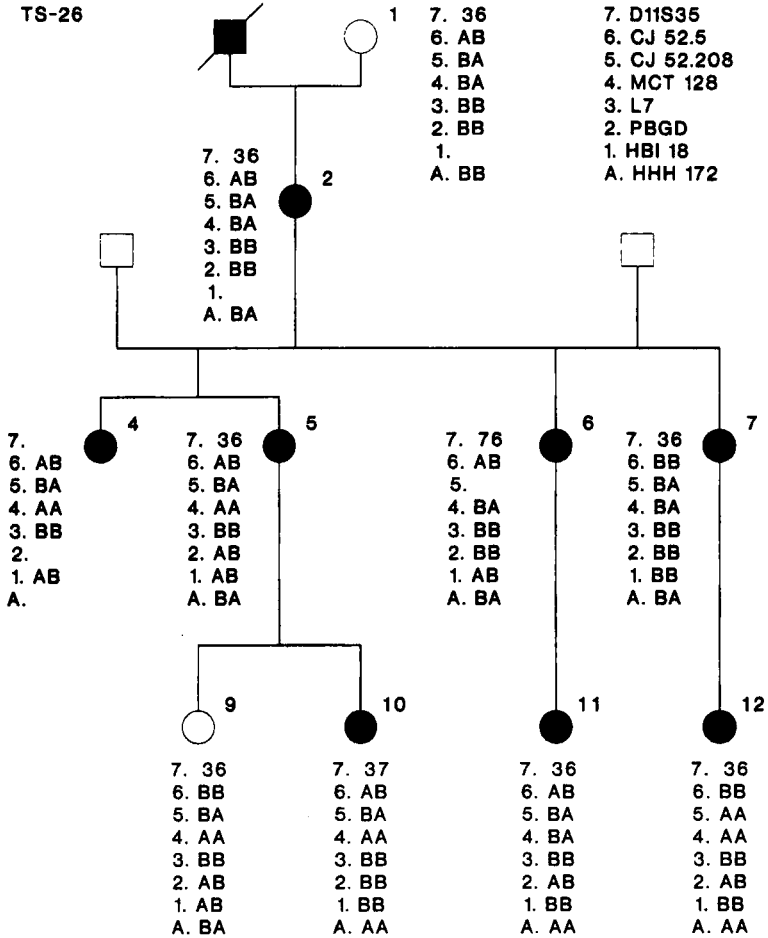
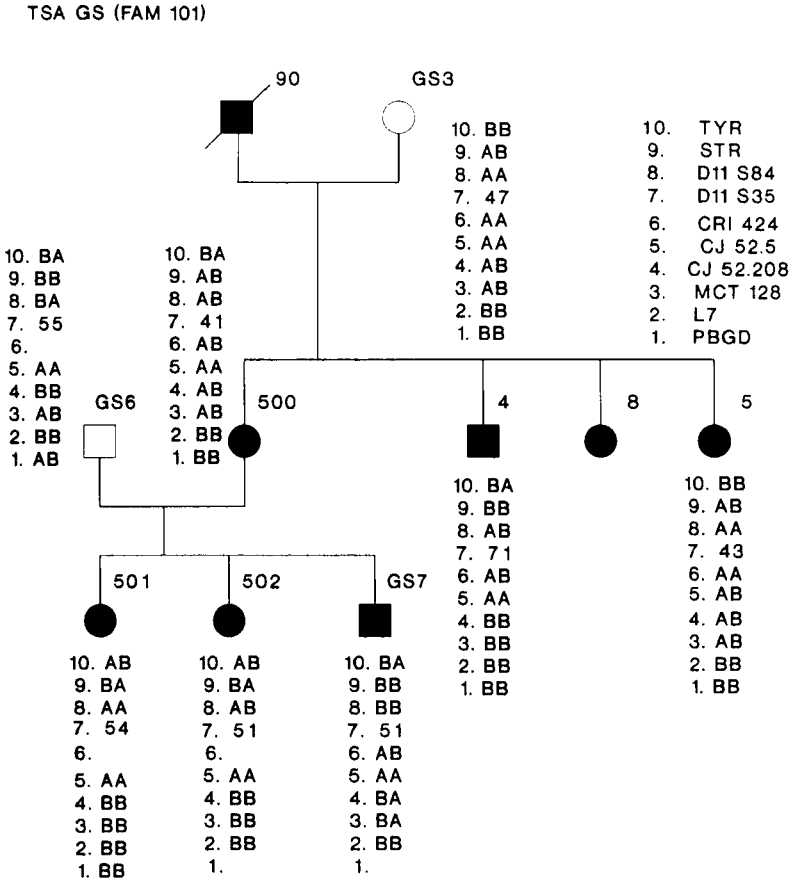

FIGURE 2.

The availability of highly informative markers will allow us to progressively narrow the chromosomal region to which the TSC1 and TSC2 genes are assigned using linkage analysis. Subsequently physical mapping using, for example, pulse-field gel electrophoresis, will need to be carried out within the defined gene region.

**ANALYSIS OF N-CAM IN TSC2 FAMILIES**

The N-CAM gene that maps to the chromosome 11q22-q23 region<sup>15</sup> represents a possible candidate gene for TSC2. Additional studies are required to define informative N-CAM polymorphisms that will allow it to be placed on the linkage



**FIGURE 3.** Legend on page 276.

map of the 11q22-q23 region. Having defined a group of TSC2 families it will now be more feasible to plan a series of experiments to determine the possible occurrence of structural chromosome changes in the vicinity of the N-CAM gene (e.g., analysis of large DNA fragments by pulse-field gel electrophoresis). It may be possible to undertake analysis of more subtle changes in the N-CAM gene using techniques such as denaturing gel electrophoresis.<sup>16</sup>

### MAPPING OF A LOCUS FOR ATAXIA TELANGIECTASIA TO CHROMOSOME 11q22-q23: SIGNIFICANCE FOR TUBEROUS SCLEROSIS

Gatti *et al.*<sup>7</sup> mapped a gene for ataxia telangiectasia to chromosome 11q22-q23. Multipoint analysis indicates that the most likely map position of this locus is between D11S144 and D11S132. It is of interest that tuberous sclerosis-like lesions have been described in patients with ataxia telangiectasia.

Amronin *et al.*<sup>7</sup> described subependymal nodules in the fourth ventricle of a patient with ataxia telangiectasia. They noted the presence within these lesions of cells that resembled those found in tubers of tuberous sclerosis. Gottoff *et al.*<sup>18</sup> described a patient with ataxia telangiectasia with brain lesions that so closely resembled those of tuberous sclerosis that they concluded that the patient had both disorders. De Leon *et al.*<sup>19</sup> described a patient with a small hamartomatous tumor in the thalamus. This lesion contained bizarre dysplastic neurons and glia and enlarged blood vessels.

The significance of these findings is not clear at this time. One possibility is that the TSC and AT genes map very close together and that a deletion in a particular region may affect both genes. Another possibility is that the TSC and AT genes are related.

### HYPOTHESES CONCERNING THE PATHOGENESIS OF TSC LESIONS AND SPECULATIONS ON THE NATURE OF POSSIBLE CANDIDATE GENES

Steffanson *et al.*<sup>20</sup> on the basis of immunohistochemical analysis of TSC lesions in the brain, postulated that the brain lesions in tuberous sclerosis may arise from defective stem cells in the primitive neural epithelium. A number of defective stem cells may fail to undergo cell migration, whereas other defective stem cells may undergo migration but on reaching the cortex may fail to differentiate and may form aggregates (cortical tubers). Reagan<sup>21</sup> noted that heterotopic neurons, sometimes of the giant cell type, may occur in the subcortical matter in patients with tuberous sclerosis. He noted that these lesions are distributed in a radial pattern between the ventricles and brain surface, and considered them to be representative of migration arrest of cells derived from the periventricular germinal matrix. Caviness<sup>22</sup> proposed that abnormal function or premature differentiation of the radial glial cells may lead to abnormal cell migration in the developing brain.

Gomez<sup>23</sup> proposed that in tuberous sclerosis certain neuronal cells may fail to migrate because they lack a functioning cell surface receptor.

### INFORMATION ON NEURONAL CELL MIGRATION FROM OTHER SPECIES

Bieber *et al.*<sup>24</sup> noted that in the developing *Drosophila* nervous system are four different membrane-associated glycoproteins (of the neural cell adhesion type) that are regionally expressed on subsets of axons and interacting glia. They noted that an analogous situation exists in vertebrates in which there is evidence that



neural cell adhesion systems are redundant and that perturbation of more than one system is necessary before effects are visualized.

Elkins *et al.*<sup>25</sup> recently reported information on an analysis of mutants which indicated that the development of a mutant phenotype in *Drosophila* was dependent on interactions between mutations at the Abelson (tyrosine kinase) locus and at a neural cell adhesion molecule locus. This report is of particular interest because the TSC1 locus in humans maps close to the ABL oncogene locus and that genes encoding neural cell adhesion molecules have also been mapped in the vicinity of the TSC genes. Because TSC is inherited as an autosomal dominant, it is unlikely that such interaction is important in familial TSC; however, it may be important in sporadic cases of TSC. Inasmuch as many such cases do not reproduce, it would not be possible to determine the mode of transmission.

Furley *et al.*<sup>26</sup> noted that navigation of axons to their targets is selected by environmental guidance cues, which include diffusible tropic functions, and the interaction of cellular matrix and cell surface glycoproteins. A number of cell surface glycoproteins, classified as neural cell adhesion molecules, have shown specific domains that interact with fibronectin, for example, the TAG neural cell adhesion molecule described by Furley *et al.*<sup>26</sup>

From the foregoing description it is clear that aberrant neuronal cell migration could be due to interruption of any one of a number of processes or interactions. Very little information is available that sheds light on the developmental origins of tuberous sclerosis lesions outside the central nervous system. Gomez<sup>23</sup> suggests that abnormal cell surface receptors may play a role in origin of angiomyolipomas, angiofibromas, and lung lesions in tuberous sclerosis. It is of interest that genes encoding the progesterone receptor and the dopamine D2 receptor have been mapped in band q23.1 of chromosome 11.<sup>10</sup>

In the pathogenesis of tuberous sclerosis lesions, one feature that needs to be explained is that certain lesions (hamartomas) undergo cellular proliferation. Of particular interest are recent studies that describe the role of cell adhesion molecules in cell proliferation and tumor progression. Vogelstein and co-workers<sup>27</sup> have cloned a tumor suppressor gene from colorectal carcinoma and determined that this gene shows significant homology to neural cell adhesion molecules, that is, immunoglobulin-like domains and fibronectin-related domains. That certain hamartomas have their growth peak at different ages<sup>1,23</sup> suggests that hormonal or growth factors and the interactions of these factors with cell surface receptors may also play a role in the origin of the lesions.

The significance of considering hypotheses on the nature of the TSC gene defect is that isolation of the TSC gene may be facilitated if we consider possible candidate genes in the particular chromosomal regions where TSC1 and TSC2 have been localized on the basis of linkage analysis with random marker loci.

### **HYPOTHESES CONCERNING FACTORS INVOLVED IN THE PATHOGENESIS OF SPECIFIC LESIONS IN TUBEROUS SCLEROSIS**

A number of investigators have suggested that in an individual who carries the TSC gene a second somatic event is required to give rise to the TSC lesions. Caviness<sup>22</sup> suggested that this second event may be gene deletion, leading to loss of function of the TSC gene region on the "normal" chromosome. By analogy with the retinoblastoma situation it seems possible the secondary somatic event may be not only deletion but also aberrant somatic crossing-over.<sup>28</sup>

Organ involvement and the extent of lesions in a particular case of TSC depend on which cells undergo the second mutation and on the timing of this second mutation in development relative to the timing of specific cell differentiations and migrations. In hamartias, such as hypomelanotic macules, the gene deletion event may lead to loss of function, for example, inadequate melanosome function. In hamartomas, such as periungual fibromas, the secondary somatic event may be linked to abnormal cellular proliferation.

### EXPERIMENTS THAT MAY ALLOW THE FOREGOING HYPOTHESES TO BE TESTED

The TSC genes are currently mapped to large regions (minimum of 10 centimorgans on chromosome 9q24 and 11q22-q23). Fine structure mapping of these chromosomal regions and the development of additional, highly polymorphic probes in these regions will enable us to identify more precisely the location of the TSC genes. In addition, the extensive observations on the pathogenesis of TSC, combined with current knowledge on the molecular biology of development, will allow us to identify candidate genes that have been mapped to these gene regions. In addition to being used as markers in linkage analysis, candidate genes and random DNA probes can be used to search for major chromosomal rearrangements, such as, by pulse field electrophoresis. In candidate genes that show tight linkage to TSC, more subtle mutations can be analyzed using denaturing gradient gel electrophoresis. More precise identification of the location of the TSC gene will enable us to select probes for analysis of TSC lesions to search for evidence of secondary somatic events that may be involved in their pathogenesis.

### ACKNOWLEDGMENTS

We wish to acknowledge the help of clinicians who put us in contact with families with tuberous sclerosis. We gratefully acknowledge the encouragement and support of the National Tuberous Sclerosis Association.

### REFERENCES

1. GOMEZ, M. R. 1988. Criteria for diagnosis. *In* Tuberous Sclerosis. Chap. 2. M. R. Gomez, ed. Raven Press. New York.
2. FLEURY, P., W. P. DE GROOT, J. W. DELLEMAN, B. VERBEETEN & I. M. FRANKENMOLLEN-WITKIEWICZ. 1980. Tuberous sclerosis: The incidence of sporadic versus familial cases. *Brain Dev.* **2**: 107-117.
3. POVEY, S., B. JANSSEN, J. ATWOOD, M. BURLEY, M. SMITH, P. FLODMAN, N. E. MORTON, J. H. EDWARDS, J. R. SAMPSON, J. YATES, J. L. HAINES, L. A. SANDKUYL, D. J. J. HALLEY, A. E. FRYER, R. MUELLER, L. AL-GHAZALI, M. SUPER & J. OSBORNE. 1991. An attempt to map two genes for tuberous sclerosis using novel two-point methods. Tuberous sclerosis and allied diseases. *Ann. N. Y. Acad. Sci.* This volume.
4. JANSSEN, L. A. J., S. POVEY, J. ATWOOD, L. A. SANDKUYL, D. LINDHOUT, P. FLODMAN, M. SMITH, J. R. SAMPSON, J. L. HAINES, E. C. MERKENS, P. FLEURY & D. J. J. HALLEY. 1991. A comparative study on genetic heterogeneity in tuberous sclerosis: Evidence for one gene on 9q34 and a second gene on 11q22-q23. Tuberous sclerosis and allied diseases. *Ann. N. Y. Acad. Sci.* This volume.

5. HAINES, J., and the tuberous sclerosis collaborative group. 1991. Genetic heterogeneity in tuberous sclerosis: Study of a large collaborative dataset. Tuberous sclerosis and allied diseases. Ann. N. Y. Acad. Sci. This volume.
6. SMITH, M., S. SMALLEY, R. CANTOR, M. PANDOLFO, M. I. GOMEZ, R. BAUMANN, K. YOSHIYAMA, Y. NAKAMURA, C. JULIER, K. DUMARS, J. HAINES, J. TROFATTER, M. A. SPENCE, D. WEEKS & M. CONNEALLY. 1990. Mapping of a gene determining tuberous sclerosis to human chromosome 11q14-q23. Genomics 6: 105-114.
7. GATTI, R. A., J. BERKEL, E. BODER, G. BRAEDT, P. CHARMLEY, P. CONCANNON, F. ERSOY, T. FOROUD, N. JASPERS, K. LANGE, M. LATHROP, M. LEPPERT, Y. NAKAMURA, P. O'CONNELL, M. PATERSON, W. SALSER, O. SANAL, J. SILVER, R. SPARKES, E. SUSI, D. WEEKS, S. WEI, R. WHITE & F. YODER. 1988. Localization of an ataxia-telangiectasia gene to chromosome 11q22-23. Nature 336: 577-580.
8. BIEBER, A., P. M. SNOW, M. HORTSCH, N. PATEL, J. ROGER JACOBS, Z. TRAUQUINA, J. SCHILLING & C. GOODMAN. 1989. *Drosophila* neuroglian: A member of the immunoglobulin superfamily with extensive homology to the vertebrate neural adhesion molecule L1. Cell 59: 447-460.
9. ELKINS, T., K. ZINN, L. MC ALLISTER, F. M. HOFFMAN & C. S. GOODMAN. 1990. Genetic analysis of a *Drosophila* neural cell adhesion molecule: Interaction of Fasciclin I and Abelson Tyrosine kinase mutations. Cell 60: 565-575.
10. KIDD, K. K., A. M. BOWCOCK, J. SCHMIDTKE, R. R. TRACK, F. RICCIUTI, G. HUTCHINGS, A. BALE, P. PEARSON & H. F. WILLARD. 1989. Report of the DNA committee and catalogs of cloned and mapped genes and DNA polymorphisms. Cytogenet. Cell Genet. 51: 622-947.
11. JULIER, C., Y. NAKAMURA, M. LATHROP, P. O'CONNELL, M. LEPPERT, M. LITT, J.-M. LALOUEL & R. WHITE. 1990. Detailed map of the long arm of chromosome 11. Genomics 7: 335-345.
12. M. LITT, V. SHARMA & J. A. LUTY. 1989. A highly polymorphic (TG) n microsatellite at the D11S35 locus. Cytogenet. Cell Genet. 51: 1034.
13. CHARMLEY, P., T. FOROUD, S. WEI, P. CONCANNON, D. WEEKS, K. LANGE & R. A. GATTI. 1990. A primary map of the human chromosome 11q22-23 region. Genomics 4: 316-323.
14. WEBER, J. L. & P. E. MAY. 1989. Abundant class of human DNA polymorphisms which can be typed using the polymerase chain reaction Am. J. Hum. Genet. 44: 388-396.
15. NGUYEN, C., J.-F. MATTEI, M. F. SANTONI, C. GORIDIS & B. R. JORDAN. 1986. Localization of the NCam gene to band q23 of chromosome 11. J. Cell Biol. 102: 711-715.
16. L. S. LERMAN, K. SILVERSTEIN & E. GRINFELD. 1986. Searching for gene defects by denaturing gel electrophoresis. Cold Spring Harbor Symposia on Quantitative Biology LI: 275-279.
17. AMRONIN, G., E. BODER & R. TEPLITZ. 1979. Ataxia telangiectasia with a 32 year survival J. Neuropathol. Exp. Neurol. 138: 621-643.
18. GOTOFF, S. P., E. J. AMIRMOKRI & LIEBNER. 1967. Ataxia telangiectasia: Neoplasia, untoward responses to X-irradiation and tuberous sclerosis. Am. J. Dis. Child. 114: 617-625.
19. DE LEON, G. A., W. D. GROVER & D. S. HUFF. 1976. Neuropathologic changes in ataxia telangiectasia. Neurology 29: 847-951.
20. STEFFANSON, K., R. L. WOLLMAN & P. R. HUTTENLOCHER. 1988. Lineages of cell in the central nervous system. Chap. 7. In Tuberous Sclerosis. M. Gomez, ed. Raven Press. New York.
21. REAGAN, T. 1988. Neuropathology. Chap. 6. In Tuberous Sclerosis. M. Gomez, ed. Raven Press. New York.
22. CAVINESS, V. 1988. Epilogue. Chap. 20. In Tuberous Sclerosis. M. Gomez, ed. Raven Press. New York.
23. GOMEZ, M. 1988. Chap. 20. Unsolved Questions in Tuberous Sclerosis. M. Gomez, ed. Raven Press. New York.
24. BIEBER, A. J., P. M. SNOW, M. HORTSCH, N. J. PATEL, J. R. JACOBS Z. R. TRAUQUINA & C. GOODMAN. 1989. *Drosophila* neuroglian: A member of the immunoglobulin

- superfamily with extensive homology to the vertebrate neural cell adhesion molecule LI. *Cell* **59**: 447–450.
25. ELKINS, T., K. ZINN, L. MC ALLISTER, F. M. HOFFMAN & C. S. GOODMAN. 1990. Genetic analysis of a *Drosophila* neural cell adhesion molecule: Interaction of fasciclin I and Abelson tyrosine kinase mutations. *Cell* **60**: 565–575.
  26. FURLEY, A. J., S. B. MORTON, D. MANATO, D. KARAGOGEOS, J. DODD & T. M. JESSELL. 1990. The axonal glycoprotein TAG-1 is an immunoglobulin superfamily member with neurite outgrowth promoting activity. *Cell* **61**: 157–170.
  27. FEARSON, E. R., K. R. CHO, J. M. NIGRO, S. E. KERN, J. W. SIMONS, J. M. RUPPERT, S. R. HAMILTON, A. C. PREININGER, G. THOMAS & B. VOGELSTEIN. 1990. Identification of a chromosome 18q gene that is altered in colorectal cancer. *Science* **247**: 49–56.
  28. CAVENEY, W. K. & M. F. HANSEN. 1986. Molecular genetics of human familial cancer. Cold Spring Harbor symposia in Quantitative Biology LI: 829–835.
  29. JORDAN, B. R. 1988. Megabase methods: A quantum jump in recombinant DNA techniques. *Bioessays* **8**: 140–145.