

Lawrence Berkeley National Laboratory

Recent Work

Title

APPLICATION OF PERMANENT MAGNETS IN ACCELERATORS AND ELECTRON STORAGE RINGS

Permalink

<https://escholarship.org/uc/item/5bb8w9sb>

Author

Halbach, K.

Publication Date

1984-09-01



Lawrence Berkeley Laboratory

UNIVERSITY OF CALIFORNIA

RECEIVED
LAWRENCE
BERKELEY LABORATORY

Accelerator & Fusion Research Division

NOV 20 1984

LIBRARY AND
DOCUMENTS SECTION

Invited paper to be presented at the 30th Annual Conference on Magnetism and Magnetic Materials, San Diego, CA, November 27-30, 1984, and to be published in the Journal of Applied Physics

APPLICATION OF PERMANENT MAGNETS IN ACCELERATORS AND ELECTRON STORAGE RINGS

K. Halbach

September 1984

For Reference

Not to be taken from this room

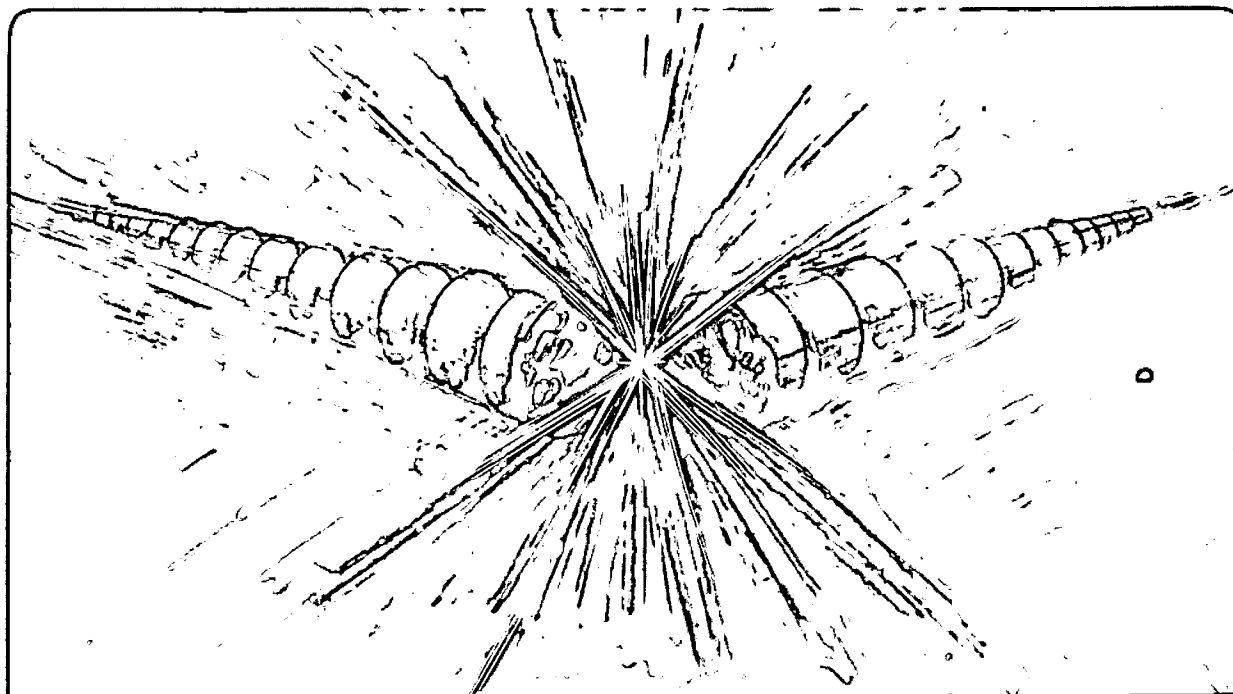

LBL-18298
1

DISCLAIMER

This document was prepared as an account of work sponsored by the United States Government. While this document is believed to contain correct information, neither the United States Government nor any agency thereof, nor the Regents of the University of California, nor any of their employees, makes any warranty, express or implied, or assumes any legal responsibility for the accuracy, completeness, or usefulness of any information, apparatus, product, or process disclosed, or represents that its use would not infringe privately owned rights. Reference herein to any specific commercial product, process, or service by its trade name, trademark, manufacturer, or otherwise, does not necessarily constitute or imply its endorsement, recommendation, or favoring by the United States Government or any agency thereof, or the Regents of the University of California. The views and opinions of authors expressed herein do not necessarily state or reflect those of the United States Government or any agency thereof or the Regents of the University of California.

APPLICATION OF PERMANENT MAGNETS IN ACCELERATORS AND
ELECTRON STORAGE RINGS

Klaus Halbach

Lawrence Berkeley Laboratory
University of California
Berkeley, California 94720

September 1984

This work was supported by the U.S. Department of Energy
under Contract Number DE-AC03-76SF00098.

APPLICATION OF PERMANENT MAGNETS IN ACCELERATORS AND
ELECTRON STORAGE RINGS (Invited)

Klaus Halbach, Center for X-Ray Optics,
Lawrence Berkeley Laboratory, Berkeley, CA 94720

After an explanation of the general circumstances in which the use of permanent magnets in accelerators is desirable, a number of specific magnets will be discussed. That discussion includes magnets needed for the operation of accelerators as well as magnets that are employed for the utilization of charged particle beams, such as the production of synchrotron radiation.

PACS 29
85,70

Generic Advantages of Permanent Magnets

Before describing some specific devices, it is useful to discuss the general circumstances under which the use of permanent magnets (PM) is indicated, and what the preferable PM materials are.

When one scales an electromagnet in all dimensions while keeping the magnetic field at equivalent locations fixed, it is easy to see that the current density in the coils scales inversely proportional to the linear dimensions L of the magnet. Since superconductors have an upper limit for the current density j that can be carried, and dissipative coils have an upper limit for j due to the need to remove the dissipated power, j needs to be reduced below that prescribed by simple scaling when L reaches a certain small value that depends, of course, on many details of the magnet design. When j is reduced, the field in a magnet that does not use iron obviously is also reduced, even if the total Ampere turns are maintained by increasing the coil size. The same is also true for a magnet using iron, since an increase of the coil size invariably leads to a field reduction due to increased saturation of the iron. PM, on the other hand, can be scaled to any size without any loss in field strength. From this follows that when it is necessary that a magnetically significant dimension of a magnet is very small, a permanent magnet will always produce higher fields than an electromagnet. This means that with permanent magnets one can reach regions of parameter space that are not accessible with any other technology. The critical size below which the PM out-performs the electromagnet depends of course on a great many details of both the desired field strength and configuration as well as the properties of the readily available PM

materials. In the region of the parameter space that is accessible to both technologies, the choice of one technology over the other will be made on the grounds of cost or convenience, (main specifics: power supplies, power needed to run the system, equipment associated with cooling) and in this arena permanent magnet systems are often also preferable, but less so the larger the smallest magnetically relevant dimension becomes.

Magnetic Properties of Some PM Materials

All PM described below use anisotropic material whose magnetic properties are adequately described by

$$B_{\parallel} = B_r + \mu_0 \mu_{\parallel} H \quad ; \quad B_{\parallel} > 0 \quad (1)$$

$$B_{\perp} = \mu_0 \mu_{\perp} H_{\perp} \quad (2)$$

In these equations, \parallel and \perp refer to the direction parallel and perpendicular to the preferred direction of the material, the so-called easy axis. Depending on the application, it is necessary that eq. (1) holds well into the second quadrant (and for some strong magnets without the use of iron even in the third quadrant) of the B-H coordinates. It is further assumed that $\mu_{\parallel} - 1$ and $\mu_{\perp} - 1$ is smaller than .1 ($\leq .05$ for rare earth cobalt). The materials that satisfy these conditions are some of the ferrites ($B_r = .2 - .35T$), rare earth cobalt ($B_r = .8 - 1T$) and Neodymium Iron ($B_r = 1 - 1.2T$). Even though the last two mentioned materials are the most powerful PM materials, strength is not the only reason for

preferring them for the design of magnets for very demanding applications: The above mentioned properties allow, as a very good approximation, the application of linear superposition of the effects of different blocks of PM material (as long as there is not strongly saturated iron present). The resulting simple theory gives a very good understanding of the properties of systems composed of these materials, and good designs follow rather easily from that good understanding.

It is easy to show that the magnetic field produced by a uniformly magnetized block of PM material with the above described properties is, in very good approximation, the same as the field produced by either currents or charges on the surface of the block. For that reason, we refer to this class of material to current sheet equivalent material or charge sheet equivalent material (CSEM).

Magnetic lenses and related magnets for high energy accelerators and storage rings

Most accelerator magnets are considerably longer than the radius of their useful field aperture. For that as well as some more sophisticated reasons, the properties of most interest are the two dimensional (2D) aspects of the magnetic fields produced by these magnets, and we will discuss only these aspects here.

Nearly all accelerator magnets are multipole magnets whose 2D fields can be derived from a scalar potential of the form

$$V = \text{Const. } r^n \cos(n\theta); n = \text{integer.} \quad (3)$$

Among these magnets, those with $n = 2$ (quadrupoles) are used most often, closely followed by those with $n = 1$. Corrective magnets with $n = 3; 4$ are also used, but in much smaller numbers.

To design an iron-less magnet that produces a potential according to eq. (3), validity of linear superposition of fields from different pieces of the CSEM makes the question "what is the optimum orientation of the easy axis as function of r and θ to contribute most to a potential described by eq. (3)?" (See Fig. 1) a reasonable question. The answer to that question (see ref (1)) is

$$\alpha(r, \theta) = (n + 1)\theta \quad (4)$$

Unfortunately, it would be exceedingly difficult to make material according to that prescription, but the next best thing, namely approximating eq. (4) by segmentation, gives nearly the same performance. Fig. 2 shows schematically a quadrupole designed this way, with the arrows inside the trapezoidal blocks indicating the easy axis orientation in the blocks. The field at the aperture radius of such a magnet is given by (ref. 2)

$$B(r_1) = B_r \frac{n}{n-1} (\cos \pi/M)^n \frac{\sin(n\pi/M)}{n\pi/M} \left(1 - \left(\frac{r_1}{r_2} \right)^{n-1} \right); \quad n > 1 \quad (5a)$$

$$B(r_1) = B_r \frac{\sin(2\pi/M)}{2\pi/M} \ln(r_2/r_1); \quad n = 1 \quad (5b)$$

with r_1, r_2 representing the inside and outside radius of the magnet, and M = number of blocks in a magnet. In deriving eq. (5), it has been assumed that $\mu_n = \mu_1 = 1$ in eq.s (1) and (2), and that they are valid over the whole range of values of B, H occurring in the

magnet, particularly down to $\mu_0 H_{11} = -B(r_1)$. Notice, in particular, that for $n = 2$, $B(r_1)$ can approach $1.5 B_r$, requiring that the B_{11} vs $\mu_0 H_{11}$ curve is a straight line well into the third quadrant. Fortunately, many manufacturers produce materials that satisfy this requirement.

The field strength achievable with this type of quadrupole exceeds that obtainable with a room temperature electromagnet with iron poles. In addition, the pure CSEM quadrupole is exceedingly compact. For that reason, this type of quadrupole is very well suited for use as drift tube quadrupole in fixed energy linear accelerators (ref. 3), and in fixed energy beam lines.

While methods have been suggested to make quadrupole systems of this type that have adjustable focusing strength (ref. 4, 5), their implementation is sufficiently difficult that, to the best knowledge of this author, no systems of that kind have been built so far. However, a class of multipole magnets has been developed that uses iron together with CSEM that produces a strong field that is easily adjustable (ref. 6, 7).

Fig. 3 shows a 2D cross section of the quadrupole member of that multipole family. The dotted areas represent iron, and the areas with arrows inside them identify CSEM, with the arrow indicating the easy axis orientation inside the block. The outer iron ring has CSEM attached to it, and by rotating that ring with the attached CSEM, one can change the field strength in the aperture region without changing the field distribution. While this hybrid quadrupole is not quite as compact as the pure CSEM quadrupole, and the field strength at the aperture radius is limited (because of iron saturation) to a respectable value of about 1.2-1.4 T, the field variability is

obviously a great asset. In addition, the field distribution in the aperture region of the hybrid quadrupole is controlled by the iron, and is therefore insensitive to homogeneity of magnetization of the CSEM blocks. The volume integral of the magnetization over each CSEM block is important for equal excitation of all poles. However, an old theory of perturbation effects in iron dominated magnets (ref. 8) has been amended to include these effects, and block sorting procedures have been developed to make the resulting field errors insignificant. Two prototype hybrid quadrupoles have been built (ref. 9). Each performed as expected.

It is clear from Fig. 3 that multipoles of any order (or even hybrid magnets that produce combinations of multipole fields) can be built with this basic design. While this includes dipoles, for dipoles magnets the design shown in Fig. 4 can be advantageous. Very compact fixed field dipole magnets of this basic design have been built by Field Effects Inc. and used successfully by Los Alamos National Laboratory as spectrometer magnets.

Undulators/Wigglers for Free Electron Lasers and the Generation of Synchrotron Light.

A very effective method to obtain spontaneous or stimulated electromagnetic radiation from high energy electrons is to expose them to strong static magnetic fields that alternate (spatially) rapidly. Fig. 5 shows, schematically, such a device, a pure CSEM undulator/wiggler (U/W). In Fig. 5, the electrons travel from the left to the right, and "wiggle" in the direction perpendicular to the paper plane. Since it is desirable under most circumstances that the

electrons "see" fields that are independent of the coordinate perpendicular to the paper plane, we restrict again the discussion to the 2D aspects of the magnets. The 2D fields produced by the structure shown in Fig. 5 is dominated by (see ref. 4 for a more complete expression);

$$B_x - i B_y = 2 B_r \cos(k(x + iy)) e^{-kh(1 - e^{-kL})} \frac{\sin(\epsilon\pi/M')}{\pi/M'} \quad (6)$$

$k = 2\pi/\lambda$; $M' =$ number of blocks/period in one array. The device obviously has to be wide enough for this formula to be applicable, and formulas to assess these 3D effects can also be found in ref. 4. Variation of field strength in this device can be achieved by variation of the clear gap between the two arrays of CSEM blocks. It is worth noting that each of the two linear arrays of CSEM in Fig. 5 can be obtained by letting the radius of a multipole magnet with fixed radial thickness and period length go to infinity, and eq. (6) can be obtained from eq. (5a) by this process.

A disadvantage of the design shown in Fig. 5 is the sensitivity of the fields to quality control in the production of the CSEM blocks. Even though assigning blocks to locations in the arrays according to measured magnetic properties (see for instance ref. 10, 11, 12) helps reduce these undesirable effects, the hybrid design shown in Fig. 6, using iron in addition to CSEM, is much less sensitive to material tolerances. In addition, the hybrid can produce stronger fields than the pure CSEM U/W. A 2D computer optimization of the peak field B in the midplane of a hybrid U/W has been performed for CSEM with $B_r = .9T$, $\mu_{||} = \mu_{\perp} = 1$, $B = .2B_r$ in the bulk of the CSEM, and the saturation characteristics of Vanadium Permendur for a number of

different values of the ratio of gap g divided by U/W period λ (ref. 13) within the range $.07 > g/\lambda \leq .7$. The results can be well represented by

$$B = 3.33 \exp (-(5.47 - 1.8g/\lambda)g/\lambda) \quad (7)$$

Here, as with the pure CSEM U/W, 3D effects have to be taken into account and corrected to actually get the performance given by (7). These procedures have been developed, but not published yet.

The U/W described above produce linearly polarized light in the forward direction. For the production of circularly polarized light one can use a helical U/W. Fig. 7 shows the 2D crosssection of a pure CSEM dipole. By making axially short segmented dipoles and rotating each short dipole by a fixed angle relative to the previous dipole, one can obtain the desired helical field. The expected performance of such a helical U/W is given in ref. 4. Another way to produce circularly polarized light with PM undulators is schematically shown in Fig. 8 (ref. 14): The two undulators produce two linearly polarized wave trains. By passing them through a monochromator of sufficiently narrow bandwidth, each wave train is lengthened, thus leading to significant overlap of the wave trains, and with it elliptically polarized light. By adjusting the electron trajectory length between the two undulators with the modulator, the phase shift between the two wave trains can be adjusted, and with it the polarization properties of the light emerging from the monochromator.

Conclusions

Permanent magnet systems have been developed that are used very successfully in accelerators and as sources of synchrotron radiation

in electron storage rings. The main advantage of these systems is the possibility to obtain, under some circumstances, performance characteristics that can not be obtained with any other technology. Under other circumstances, the advantage may be merely one of economy or convenience. A recently published proposal (ref. 15) to build an electron storage ring entirely with permanent magnets is an indication that this technology will be used even more frequently in the future.

References

- 1) K. Halbach, Nucl. Instr. and Meth. 169, 1, 1980.
- 2) K. Halbach, IEEE Trans. on Nucl. Sci., NS-26, 3882, 1979.
- 3) R.F. Holsinger, Proc. 1979 Lin. Sec. Conf., BNL 51134, 373.
- 4) K. Halbach, Nucl. Instr. and Meth. 187, 109, 1981.
- 5) R.L. Gluckstern, R.F. Holsinger, IEEE Trans. Nucl. Sci, NS-30, 3326, 1983.
- 6) K. Halbach, Nucl. Instr. and Meth. 206, 353, 1983.
- 7) K. Halbach, IEEE Trans. on Nucl. Sci. NS-30, 3323, 1983
- 8) K. Halbach, Nucl. Instr. and Meth. 74, 147, 1969.
- 9) Private communications: One was built under the direction of J.T. Tanabe at U.C. LBL, and one under the direction of R.F. Holsinger at Field Effects Inc. for Los Alamos National Lab.
- 10) K. Halbach, J. Chin, E. Hoyer, H. Winick, R. Cronin, J. Yang, Y. Zambre. Trans. Nucl. Sci., NS-28, 3136, 1981.
- 11) J.M. Ortega, C. Bazin, D.A.G. Deacon, C. Depautex, P. Elleaume, Nucl. Instr. and Meth. 206, 281, 1983.
- 12) A. Luccio, P. Mortazavi, L. Yü, Nucl. Instr. and Meth. 219, 213, 1983.
- 13) K. Halbach, Journal de Physique 44, C1-211, 1983.
- 14) K-J. Kim, Nucl. Instr. and Meth. 219, 425, 1984.
- 15) J. Le Duff, Y. Petroff, IEEE Trans. on Nucl. Sci. NS-30, 1983

Figure Captions

- 1) Optimization of Easy Axis Orientation.
- 2) Pure CSEM Segmented Quadrupole.
- 3) Adjustable Strength Hybrid Quadrupole.
- 4) Hybrid Dipole.
- 5) Pure CSEM Undulator.
- 6) Hybrid Wiggler/Undulator.
- 7) Pure CSEM Dipole.
- 8) System for Production of Elliptically Polarized Synchrotron Light.

This work was supported by the Office of Basic Energy Science
U.S. Department of Energy, under Contract Number DE-AC03-76SF0098

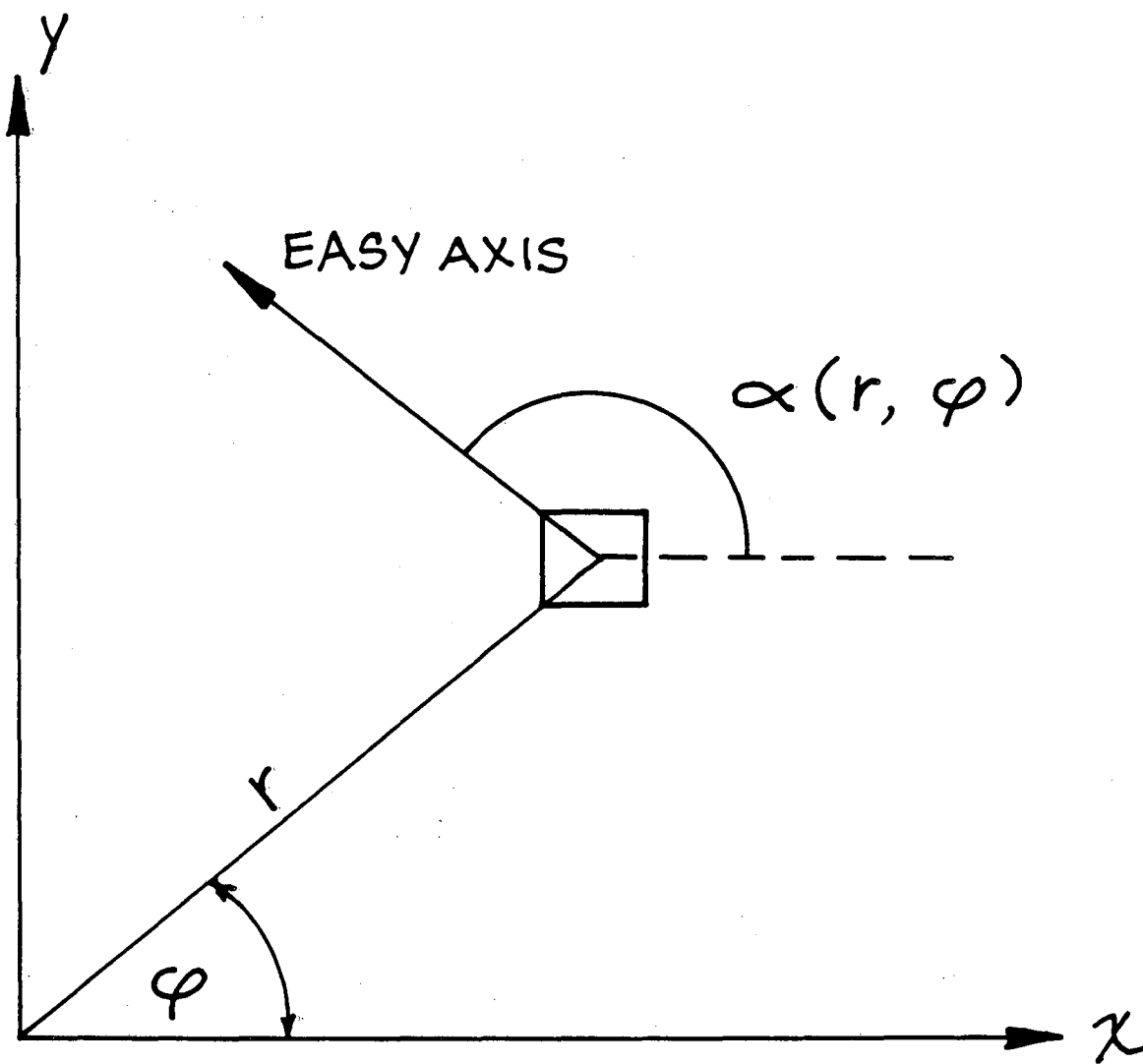

XBL 849-3878

Figure 1

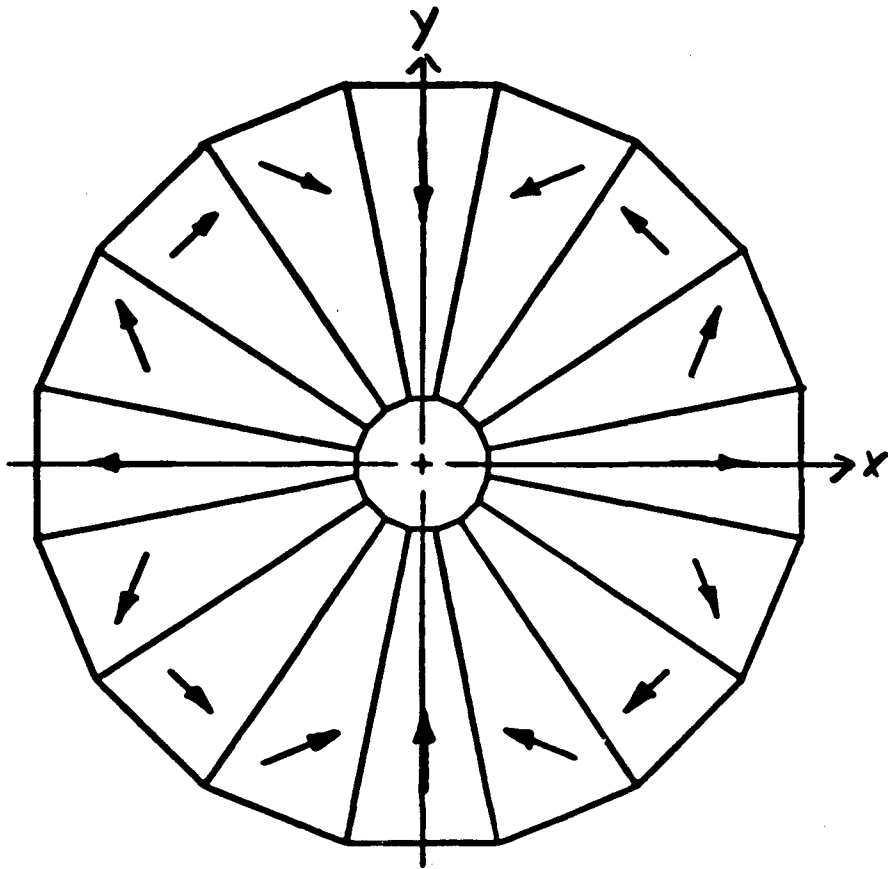

XBL 792-8538

Figure 2

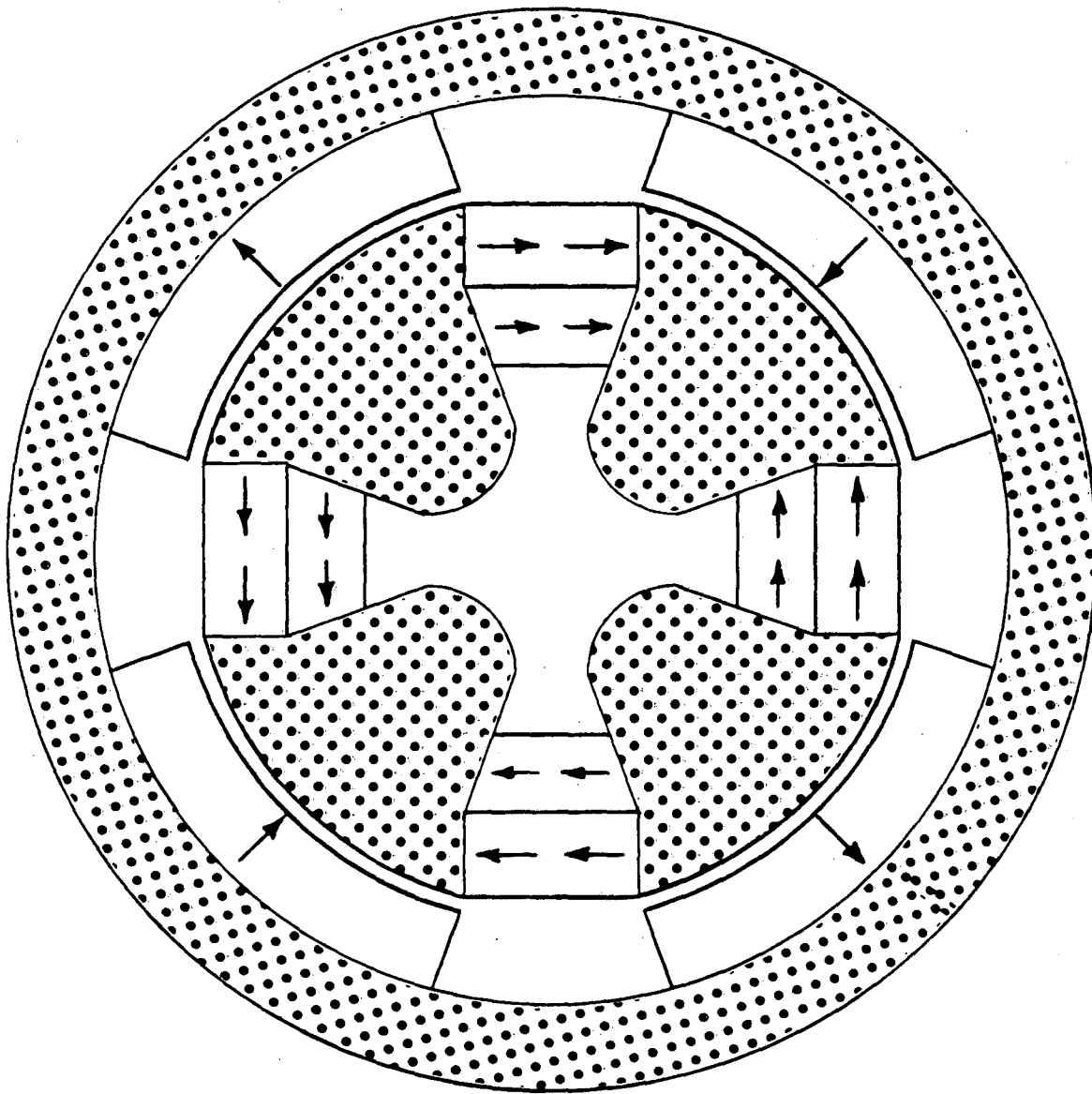

XBL 829-11424

Figure 3

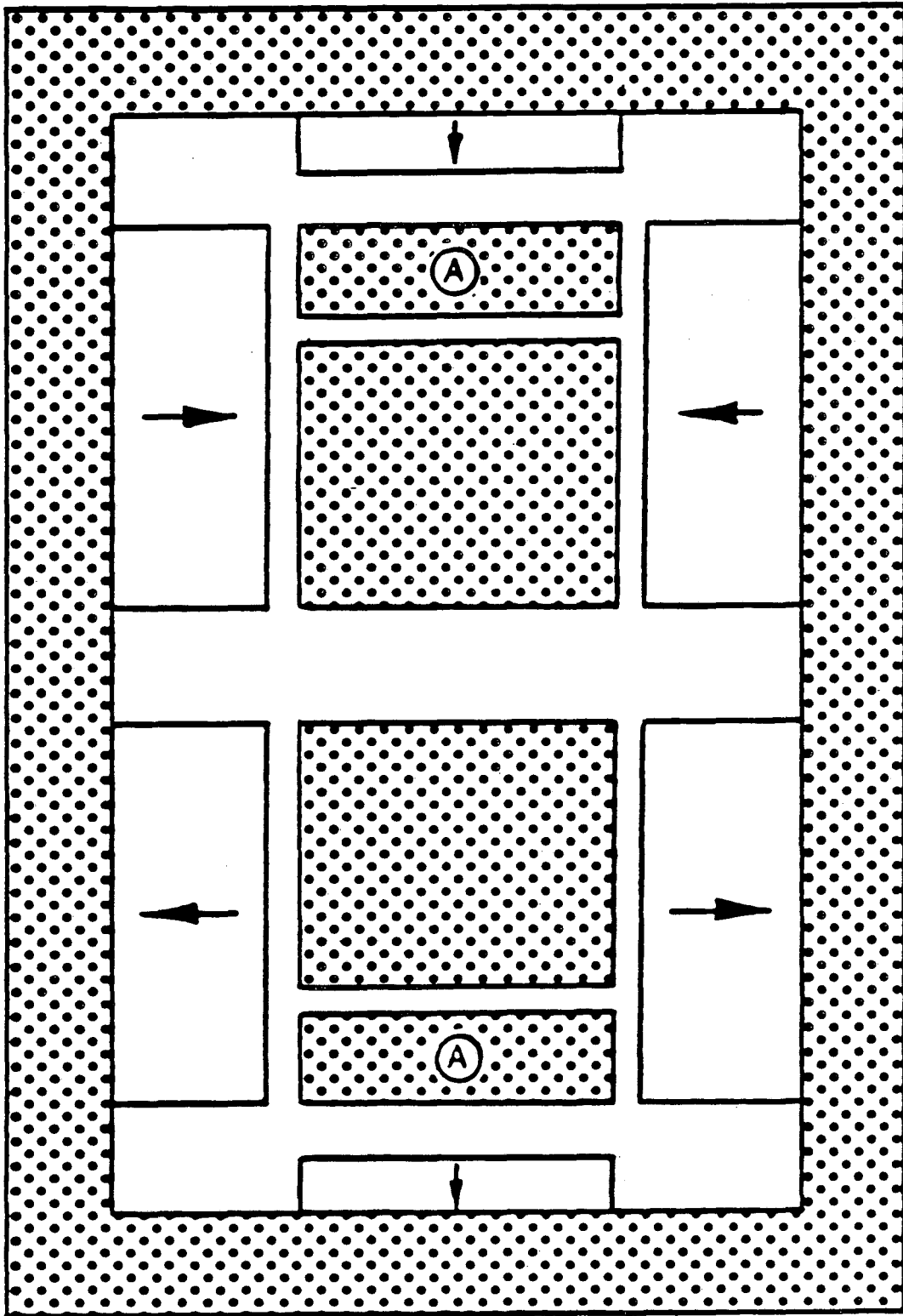

XBL 849-3882

Figure 4

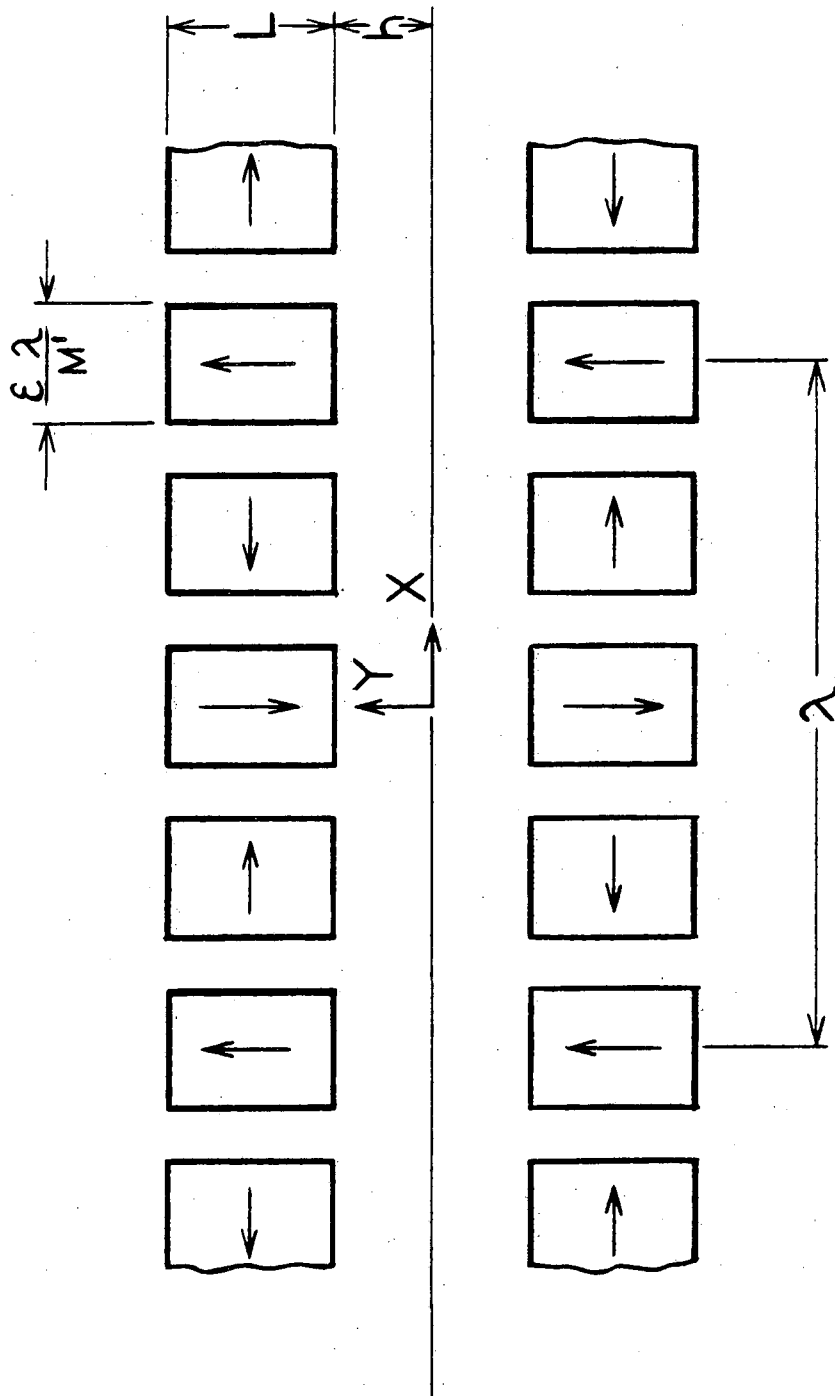

XBL 808-11421

Figure 5

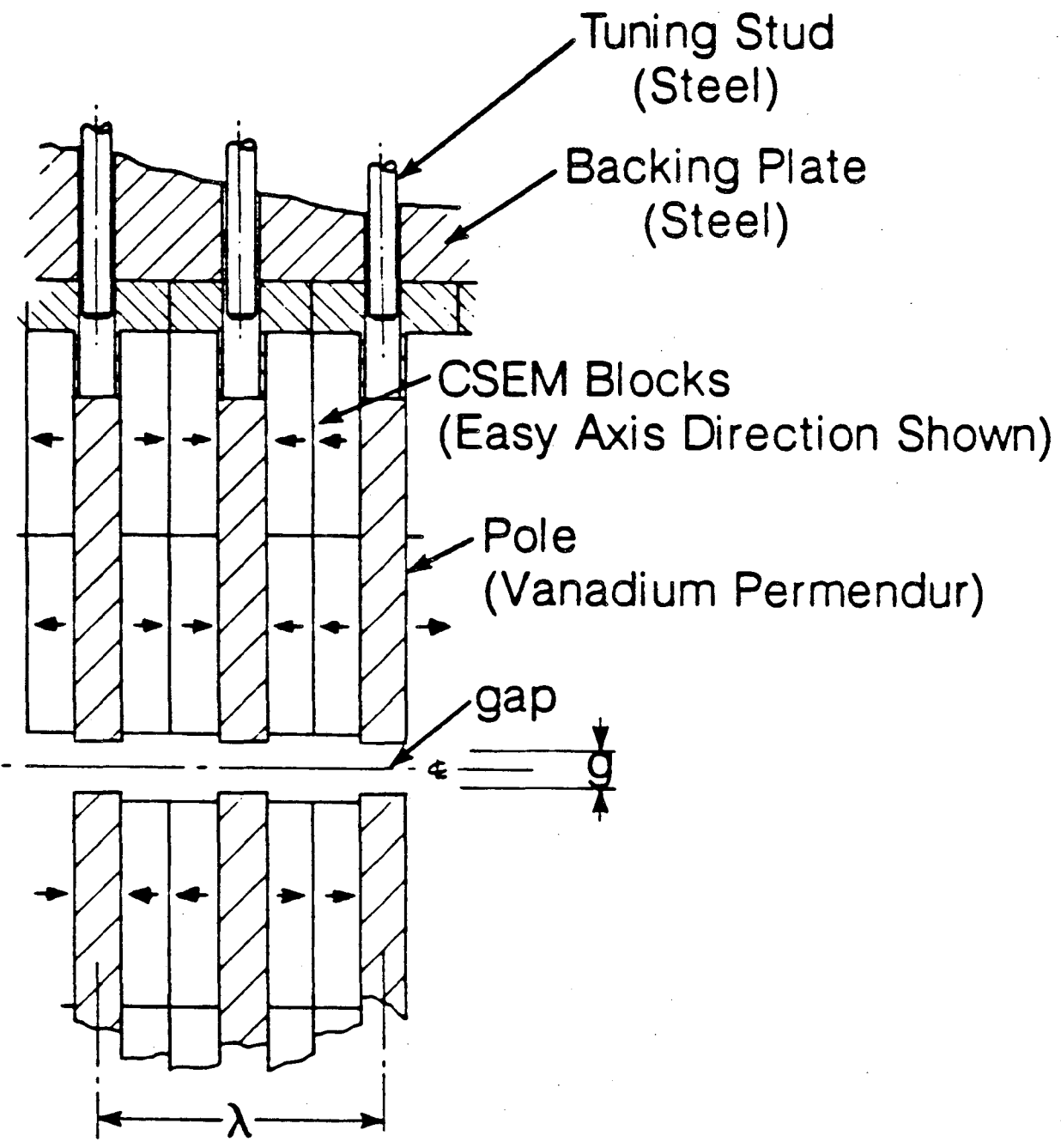

XBL 849-3879

Figure 6

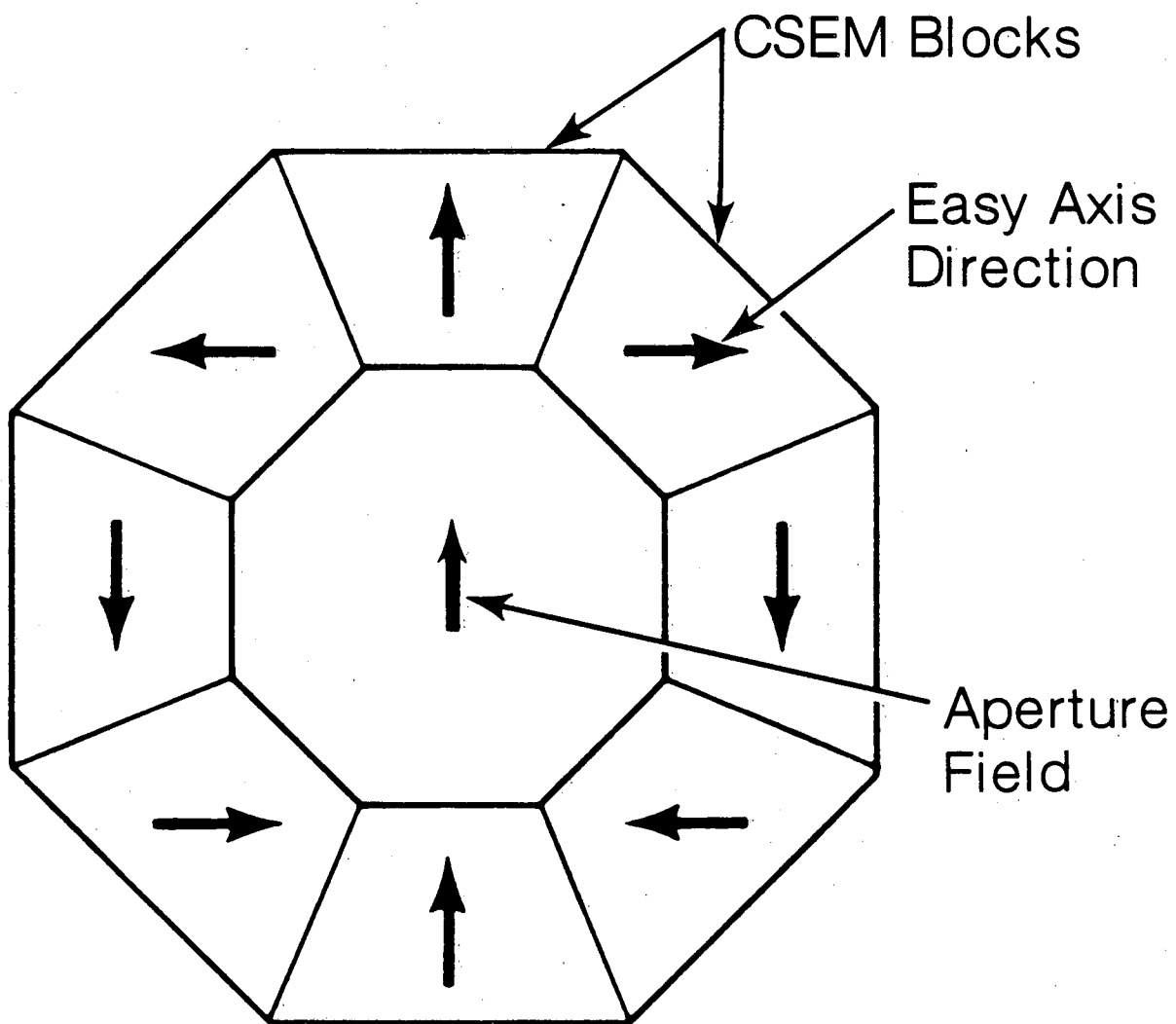

XBL 849-3880

Figure 7

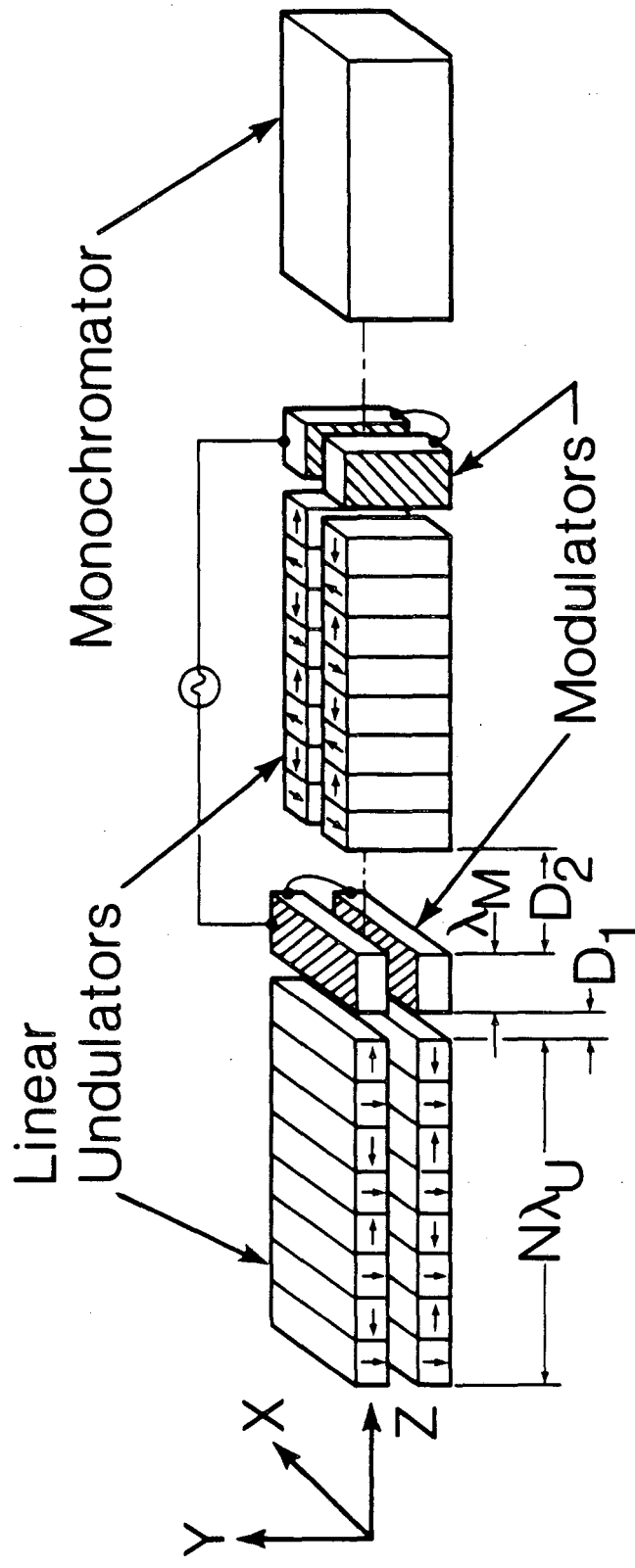

XBL 849-3881

Figure 8

This report was done with support from the Department of Energy. Any conclusions or opinions expressed in this report represent solely those of the author(s) and not necessarily those of The Regents of the University of California, the Lawrence Berkeley Laboratory or the Department of Energy.

Reference to a company or product name does not imply approval or recommendation of the product by the University of California or the U.S. Department of Energy to the exclusion of others that may be suitable.

TECHNICAL INFORMATION DEPARTMENT
LAWRENCE BERKELEY LABORATORY
UNIVERSITY OF CALIFORNIA
BERKELEY, CALIFORNIA 94720