

Lawrence Berkeley National Laboratory

Recent Work

Title

SOME EFFECTS OF HEATING AND DRYING ON THE PROPERTIES OF NUCLEAR EMULSIONS

Permalink

<https://escholarship.org/uc/item/5bq884js>

Authors

Dyer, John N.
Heckman, Harry H.

Publication Date

1966-10-27

University of California

Ernest O. Lawrence Radiation Laboratory

SOME EFFECTS OF HEATING AND DRYING
ON THE PROPERTIES OF NUCLEAR EMULSIONS

TWO-WEEK LOAN COPY

*This is a Library Circulating Copy
which may be borrowed for two weeks.
For a personal retention copy, call
Tech. Info. Division, Ext. 5545*

Berkeley, California

DISCLAIMER

This document was prepared as an account of work sponsored by the United States Government. While this document is believed to contain correct information, neither the United States Government nor any agency thereof, nor the Regents of the University of California, nor any of their employees, makes any warranty, express or implied, or assumes any legal responsibility for the accuracy, completeness, or usefulness of any information, apparatus, product, or process disclosed, or represents that its use would not infringe privately owned rights. Reference herein to any specific commercial product, process, or service by its trade name, trademark, manufacturer, or otherwise, does not necessarily constitute or imply its endorsement, recommendation, or favoring by the United States Government or any agency thereof, or the Regents of the University of California. The views and opinions of authors expressed herein do not necessarily state or reflect those of the United States Government or any agency thereof or the Regents of the University of California.

Submitted to Nuclear Instruments
and Methods

UCRL-17229
Preprint

UNIVERSITY OF CALIFORNIA

Lawrence Radiation Laboratory
Berkeley, California

AEC Contract No. W-7405-eng-48

SOME EFFECTS OF HEATING AND DRYING
ON THE PROPERTIES OF NUCLEAR EMULSIONS

John N. Dyer and Harry H. Heckman

October 27, 1966

SOME EFFECTS OF HEATING AND DRYING
ON THE PROPERTIES OF NUCLEAR EMULSIONS*

John N. Dyer

U. S. Naval Postgraduate School
Monterey, California

and

Harry H. Heckman

Lawrence Radiation Laboratory
University of California
Berkeley, California

October 27, 1966

ABSTRACT

Some effects of heating and drying Ilford types G and K emulsions prior to exposure and processing are reported. It was found that some gain in sensitivity was obtained, but that an increase in "fog" background offset any advantage. For each emulsion type there is a critical temperature above which the growth of fog background soon makes the emulsion useless. Attempts to remove this fog by eradication showed that track images are removed more easily than the fog, so that the usefulness of emulsions which have been heated too much cannot be regained. No changes in the sensitivity of emulsions to near-minimum ionizing particles was observed between -20 and 50°C.

INTRODUCTION

We report here the results of a number of experiments carried out with Ilford G.2, G.5, and K.5 emulsions, designed to determine the effects of high temperature and low humidity on the photographic properties of these emulsions. The experiments can be divided into two groups: (1) emulsion stacks in which a temperature gradient was maintained (-20 to +100°C) prior to processing, and (2) stacks that were held at constant uniform temperature prior to processing. The emulsions were dried prior to heating and maintained at nearly zero relative humidity during heating. The density of random fog grains and the blob-density of minimum tracks were measured in the processed emulsions. Variations in the processing times (the time in the "hot stage") were studied. Several experiments were attempted on the eradication of fog and track grains.

We believe our most significant result to be the determination of a rather critical "threshold temperature," which depends on emulsion type and the time of preheating, above which the growth of fog background makes the emulsion useless. Eradication is of little value in reducing this fog, as the eradication procedure more readily removes track images.

Contrary to the reported properties of NIKFI emulsion,¹ we find that track images in Ilford emulsions are not appreciably enhanced by drying and heating prior to exposure and processing.

EFFECTS OF HEATING PRIOR TO PROCESSING

A. Temperature-Gradient Stacks

To investigate the effects of heating emulsions prior to exposure and processing, we assembled emulsion stacks consisting of strips of pellicles about 3/4 in. wide and 8 in. long. Each stack contained samples of G.2, G.5, and K.5 emulsion. Several different manufacturers' batches were represented among the stacks, so that the results represent an average over emulsions furnished by the manufacturer. These emulsions were dried (either by vacuum or chemical desiccation) for several days before being made into stacks, and were then assembled and placed in an apparatus, described in Appendix II, which produced and maintained a temperature gradient between the ends of the pellicles. Thus a steady-state temperature difference from about -20 to +100°C was established. We note here that while emulsions at normal humidity lose their mechanical rigidity and tend to adhere to each other at temperatures of around 50 to 60°C, dry emulsions can be heated to about 90°C without "sticking" when made into stacks.

The most striking feature of these experiments is shown in Figs. 1 through 3. In each case it is evident that there is a sharp increase in the density of random background grains (fog) over a rather narrow temperature range. In general, the temperature at which this increase occurs decreases with the length of time the emulsions were maintained at elevated temperatures, but we note the following:

1. Even for times as short as an hour, a temperature of 60 to 70°C causes a marked increase in fog in G.5 and K.5 emulsions. On the other

hand, these emulsions seem relatively unaffected by a temperature of about 40°C even if maintained for a week.

2. G.2 emulsions show qualitatively the same behavior, but the onset of fog occurs some 10 to 15°C higher.

There are fluctuations among the various stacks, but we believe that these can be attributed to variations in manufacture of the emulsions and in the processing used. It is significant that the same trends were observed in emulsions processed at two laboratories, Lawrence Radiation Laboratory (LRL) and the U. S. Naval Postgraduate School (NPGS).² (The generally higher backgrounds in the LRL emulsions are attributed, in part, to the greater age of the emulsion used in the LRL experiments.)

Some qualitative features of the dried and heated emulsions were noted:

1. At temperatures slightly above the onset of fog, the emulsions showed a general darkening of the gelatin, which made them opaque.

2. Most emulsions became quite brittle and broke at the heated end when the stacks were disassembled -- roughly at about 90°C.

One stack (marked "normal" on the graphs) was heated without prior drying. This stack seemed to behave in the same way as the dried emulsions, although the hot end could be extended to only about 60°C.

The data from the temperature-gradient stacks is presented in a different way in Figs. 4, 5, and 6. Data points for these curves are taken from Figs. 1 through 3, after first normalizing the K.5 and G.5 curves to 1 grain per $10^3 \mu^3$ at 0°C. These curves show rather clearly the growth of fog background during the first day of heating.

B. Constant Temperature Stacks

The data from the temperature-gradient stacks indicate a threshold temperature of 50 to 60°C. Therefore, several batches of emulsions were dried and heated for various times at about this temperature in order to investigate further this critical temperature range. The data are shown in Figs. 7 through 9. Each curve represents a different emulsion batch -- our technique was to cut a single large pellicle into smaller pieces, dry them, and place them in an oven at intervals of time. The entire batch was removed from the oven and processed together.

We interpret these data as follows:

- a. G.5 emulsion: From Fig. 1, the threshold is at 40 to 50°C. Figure 7 indicates an increase of fog as a function of time for temperatures slightly above the threshold.
- b. K.5 emulsion: This behaves similarly to G.5, but has a more pronounced increase in fog with time.
- c. G.2 emulsions: From Fig. 3, the threshold temperature is above 60°C. Figure 9 indicates that heating below 60°, even for 9 to 10 days, has little effect on the fog.

ERADICATION EXPERIMENTS

Some pellicles from the temperature-gradient stacks were separated after heating and subjected to the following eradication procedure before processing: The pellicles were placed in an environment of ~100% humidity at 35°C from 3 to 6 days. The emulsions were then processed in the same manner as the remainder of the stack. These data are not represented by a graph because:

- a. The threshold temperature was not appreciably lowered by eradication -- that is, the fog which occurs at high temperatures was not removed.
- b. No difference was noted in eradicating for 6 days rather than 3.
- c. The major result was a decrease in the fog below threshold, particularly in K.5 emulsion.

Since it seemed that whatever eradication did occur took place within 3 days, samples of each emulsion type were exposed to a Co^{60} source, and the eradication experiments were repeated on these emulsions using times from 0 to 3-3/4 days. The results are shown in Fig. 10.

We also carried out the eradication of emulsion (for times 0 to 3-3/4 days) exposed to a Co^{60} source to compare the rates of eradication of fog due to low-energy electron tracks (Fig. 10) and that produced by subjecting the emulsions to high temperatures. Although the eradication-rate data showed considerable fluctuation, we conclude that eradication effectively removes random fog and particle tracks at comparable rates from K.5 emulsion, and to a lesser extent, G.5 emulsion, and has little effect on G.2 emulsion. Further, little is gained by extending the eradication beyond about a day. Finally, in the case of fog caused by temperatures beyond the threshold, eradication has no appreciable effect, so that emulsions once heated to this point cannot be "repaired" by the eradication procedure.

GRAIN DENSITY OF MINIMUM TRACKS

The data of the NIKFI Group indicate that a significant increase in the grain density of near-minimum tracks in NIKFI emulsions can be

obtained without an accompanying increase in fog background by drying and preheating emulsions prior to exposure. In an attempt to detect this effect in Ilford emulsions, the gradient stacks of 2, 6, and 24 hours heating were exposed to a Co^{60} source at the NPGS, and the LRL gradient stacks of 24 hours heating were exposed to a near-minimum pion beam at the 184-in. cyclotron. In each case, control plates from the same manufacturer's batch, which had not been dried or heated, were exposed simultaneously and later processed with the other pellicles. These experiments showed the following:

a. The grain density of near-minimum tracks changes very little as a function of the heating time and (or) temperature -- any increase that occurs is offset by at least an equal increase in fog background. The resolution, or ease in detecting these tracks, is if anything decreased by preheating. Figure 11 presents the temperature dependence of the blob densities of 400-MeV/c pions in G.5 emulsions that were maintained at temperature for 24 hours in the temperature-gradient stacks. The exposure to pions took place at the end of the heating period under the following conditions: (1) the temperature gradient was maintained in the stack, and (2) the stack was allowed to return to the ambient room temperature. No differences in the blob densities were observed in the two cases, as can be seen from Fig. 11. Our results show that 24 hours of heating at any temperature below the fog threshold has little effect on emulsion sensitivity and that no sensitivity maximum occurs between -20 and 50°C.³

b. The control pellicles showed about 20% lower grain density than the dried plates. This suggests that some increase in grain density

can be had simply by drying pellicles prior to exposure. Whether this is due to the prevention of some eradication of the image in emulsions at normal humidity, or to some other effect, has not been determined.

APPENDIX I. PROCESSING METHODS

The Bristol developer method was used to process the mounted emulsion pellicles. The compositions of the developer and other standard processing solutions used are listed in Table I.

The processing times in each solution for the 200- μ and 300- μ emulsions and the temperature of the solutions are listed in Table II.

Table I. Composition of standard processing solutions

| | |
|---------------------------|---------|
| <u>Bristol developer</u> | |
| <u>Cold stage</u> | |
| Distilled water | 1.0 l |
| Sodium sulfite, anhydrous | 7.2 g |
| Sodium bisulfite, meta | 1.0 g |
| Potassium bromide | 0.87 g |
| Amidol | 3.25 g |
| <u>Bristol developer</u> | |
| <u>Warm stage</u> | |
| Distilled water | 1.0 l |
| Sodium sulfite, anhydrous | 7.2 g |
| Sodium bisulfite, meta | 1.0 g |
| Potassium bromide | 0.87 g |
| Amidol | 1.3 g |
| <u>Short stop</u> | |
| Distilled water | 1.0 l |
| Acetic acid, glacial | 31.0 ml |
| <u>Fixing bath</u> | |
| Distilled water | 1.0 l |
| Sodium bisulfite, meta | 22.5 g |
| Sodium thiosulfate | 300.0 g |

In addition to the normal processing method described above, variations in processing were used. The warm development was completely omitted and some of the stacks were processed with cold-stage

development only, for times of 2-1/2, 1-1/2, and 1/2 hour. This was done to determine whether the fog background could be suppressed relative to the blob density of electron tracks by variations in development. No substantial improvement in the quality of the processed emulsions was observed.

To insure uniform processing for all pellicles of a given stack, the plates were placed in racks and always processed together. Fresh solutions were always used, and the amidol developer was never mixed more than an hour or so before it was to be used.

Table II. Processing times and temperatures

| Solutions | Temperature (°C) | Time (min) | |
|--------------------------------|---------------------|------------------------------------|-----------|
| | | 200 μ | 300 μ |
| Cold soak | 3 to 5 | 20 | 40 |
| Cold develop | 5 | 20 | 40 |
| Hot develop | 22 | 50 | 50 |
| Stop bath | 5 | 20 | 40 |
| Dilution and wash | 5 to 10 | (clearing time + 50%) ^a | |
| 50% alcohol and 5% glycerin | 5 to 10 | 20 | 40 |
| 75% alcohol and 5% glycerin | 10 | 20 | 40 |
| 95% alcohol and 5% glycerin | 10 to room temp. | 60 | 90 |

a. Demineralized water at 3% of tank volume per hour until hypo test is negative.

To avoid etching in the fixing bath, the silver-ion concentration was not allowed to exceed 10 g/l, and we attempted to maintain about 6 g/l throughout the fixing. No improvement was noted in those cases in which the hypo was preloaded with silver to about 3 g/l.

APPENDIX II. TEMPERATURE-GRADIENT APPARATUS

Emulsions in 6- by 3/4-in. strips, protected by black photographic paper, were placed between two 1- by 9-in. aluminum plates. The aluminum plates were connected to a heat source at one end and a heat sink at the other. The device used is illustrated in Fig. 12. This arrangement gave a continuous temperature gradient between the two fixed temperature sources.

To measure the temperature at various points, eight copper-constantan (No. 30-55-1) thermocouples were constructed, inserted between the central emulsion strips, and spaced from the hot to the cold end of the stack. By placing the thermocouples against the pellicle adjacent to the aluminum, and against the aluminum itself, it was determined that the isotherms were essentially perpendicular to the aluminum, so that the temperature at a point of any pellicle in a stack depended only on the distance from the hot (or cold) end of the pellicle. The thermocouples were connected to a revolving switch associated with a graphic recorder which recorded in sequence the reading from each thermocouple. Because room temperature was fairly constant, $72 \pm 2^\circ\text{F}$, it was used as the known constant temperature "cold junction" for calibrating thermocouples.

The heat source was a 100 W, 30- Ω resistor; the current flow through the resistor was used to control the temperature of the heat source. The heat sink was at the temperature of a dry ice and methanol mixture.

Emulsions at normal humidity (50 to 60%) fuse together when heated to temperatures of 50 to 60°C, but dry emulsions withstand temperatures in excess of 90°C without sticking. Therefore, by using dry emulsions, a temperature span of -20 to 100°C was possible.

The apparatus was loaded in the darkroom, placing the thermocouples at measured distances from the hot or cold end of the emulsion stack so that the temperature could be measured as a function of position. Black paper was placed around the stack to prevent light exposure and reaction of the emulsion with the aluminum. When the stack was in place and the source and sink attached, all exposed areas were covered with fitted pieces of styrofoam, and all seams taped in order to provide thermal insulation.

About an hour was required to reach steady state; in order to reach steady state as soon as possible the resistor was turned on first, allowing the heating to proceed for about 5 min before the dry-ice-methanol mixture was added. This particular process was established by trial.

ACKNOWLEDGMENTS

We are indebted to Mr. Tom Coen of LRL for handling and processing a great deal of emulsion during this experiment, and for many hours of frustrating and finally successful work on the temperature-gradient device.

Our thanks go to all of the scanners at the LRL and the NPGS, who counted many hundreds of thousands of blobs in the course of this experiment.

FOOTNOTES AND REFERENCES

*This work was done under the auspices of the U. S. Atomic Energy Commission, the Office of Naval Research, and the National Aeronautics and Space Administration, Contract NAS 9-5249.

1. C. M. Romanovskaya, C. S. Bogomolov, and M. Yu. Deberdeev, NIKFI Institute, Moscow, 1964.
2. K. H. Bauer, J. M. McCulloch, and R. H. Rambo, U. S. Naval Postgraduate School, Monterey, Calif. (thesis), May 1966. This reference contains additional data and technical details of the work carried out at the U. S. Naval Postgraduate School.
3. Walter H. Barkas, Nuclear Research Emulsions (Academic Press, New York, 1963).

FIGURE LEGENDS

- Fig. 1. Density of random-background grains (fog) vs temperature for desiccated G.5 Ilford emulsion subjected to a temperature gradient of -20 to +100°C. The numbers indicate the time (hours) the emulsions were maintained at temperature prior to processing. The curve denoted "normal" is for a sample of heated, but undesiccated emulsion. Representative data points are shown.
- Fig. 2. Density of random background grains vs temperature in desiccated K.5 Ilford emulsion.
- Fig. 3. Density of random background grains vs temperature in desiccated G.2 Ilford emulsion.
- Fig. 4. Fog density in desiccated G.5 emulsion at 50, 60, and 70°C vs time. The fog-density curves for the G.5 and K.5 data (see Fig. 5) have been normalized to 1 grain per $10^3 \mu^3$ at 0°C (not shown).
- Fig. 5. Fog density in desiccated K.5 emulsion at 50, 60, and 70°C vs time.
- Fig. 6. Fog density in desiccated G.2 emulsion at 60, 70, and 80°C vs time.
- Fig. 7. Time dependence of the fog density in desiccated G.5 emulsion held at constant temperatures. Temperatures are indicated for each curve.
- Fig. 8. Time dependence of the fog density in desiccated K.5 emulsion held at constant temperatures. Temperatures are indicated for each curve.

Fig. 9. Time dependence of the fog density in desiccated G.2 emulsion held at constant temperatures. Temperatures are indicated for each curve.

Fig. 10. Fog density in Ilford emulsion exposed to a Co^{60} source, as a function of eradication time.

Fig. 11. Grain density of 400-MeV/c pions vs temperature in the temperature-gradient stacks. Emulsions were maintained at temperature for 24 h preceding exposure. The cross-hatching indicates onset of fog background.

Fig. 12. Temperature gradient device. (1) Resistor heat source, (2) aluminum plates, (3) emulsion stacks, (4) copper-constantan thermocouples, and (5) methanol-dry-ice heat sink.

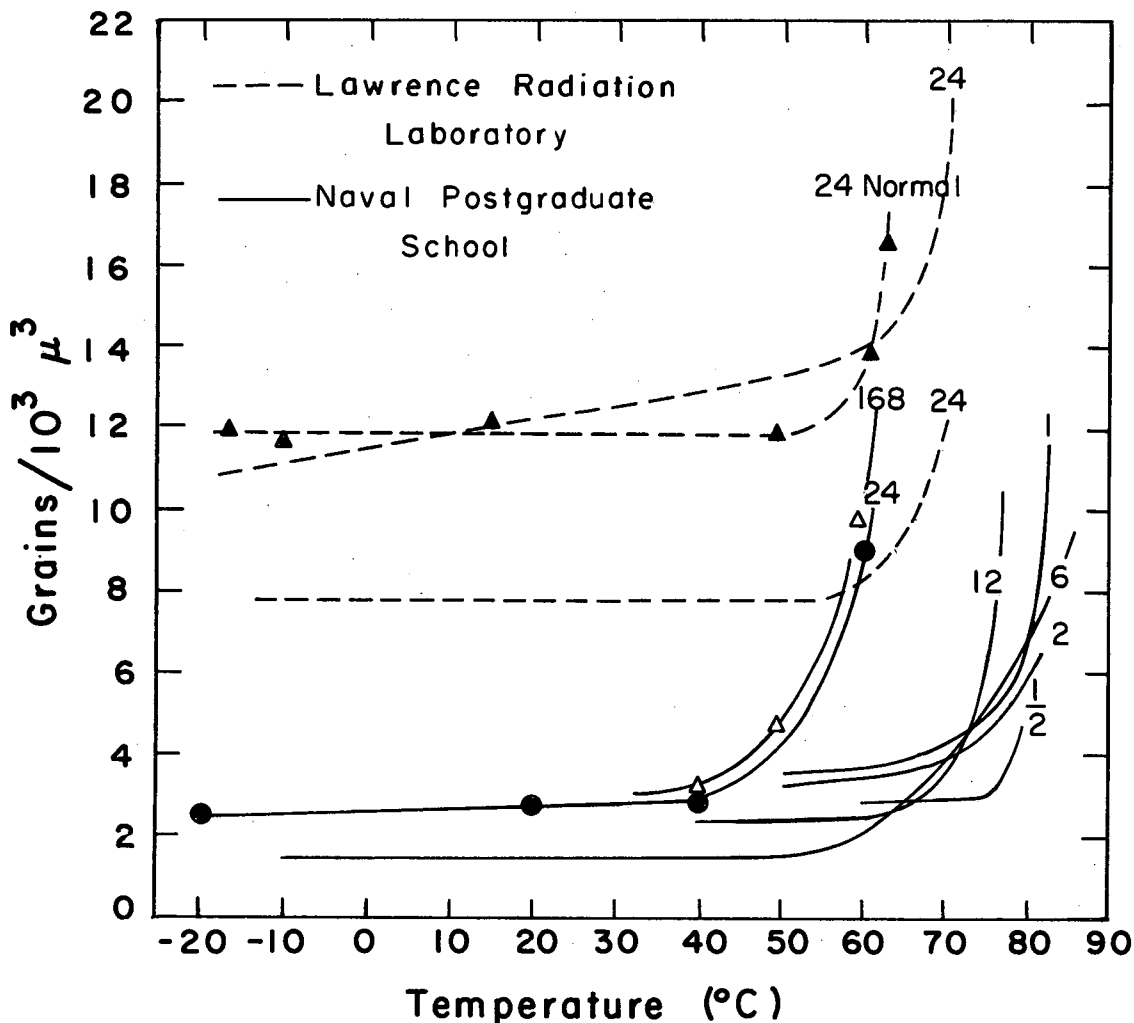

MUB-13936

Fig. 1

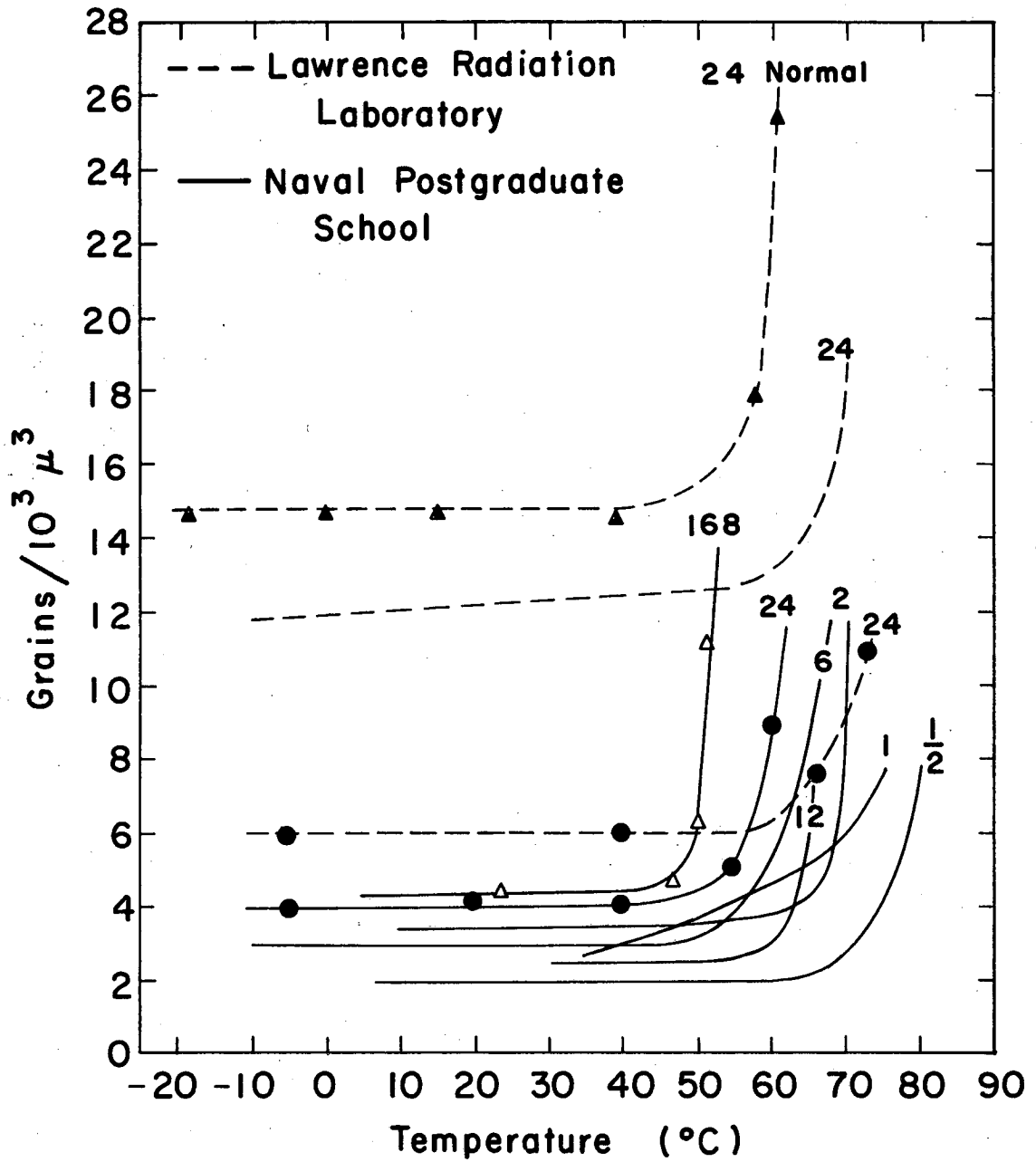

MUB 13933

Fig. 2

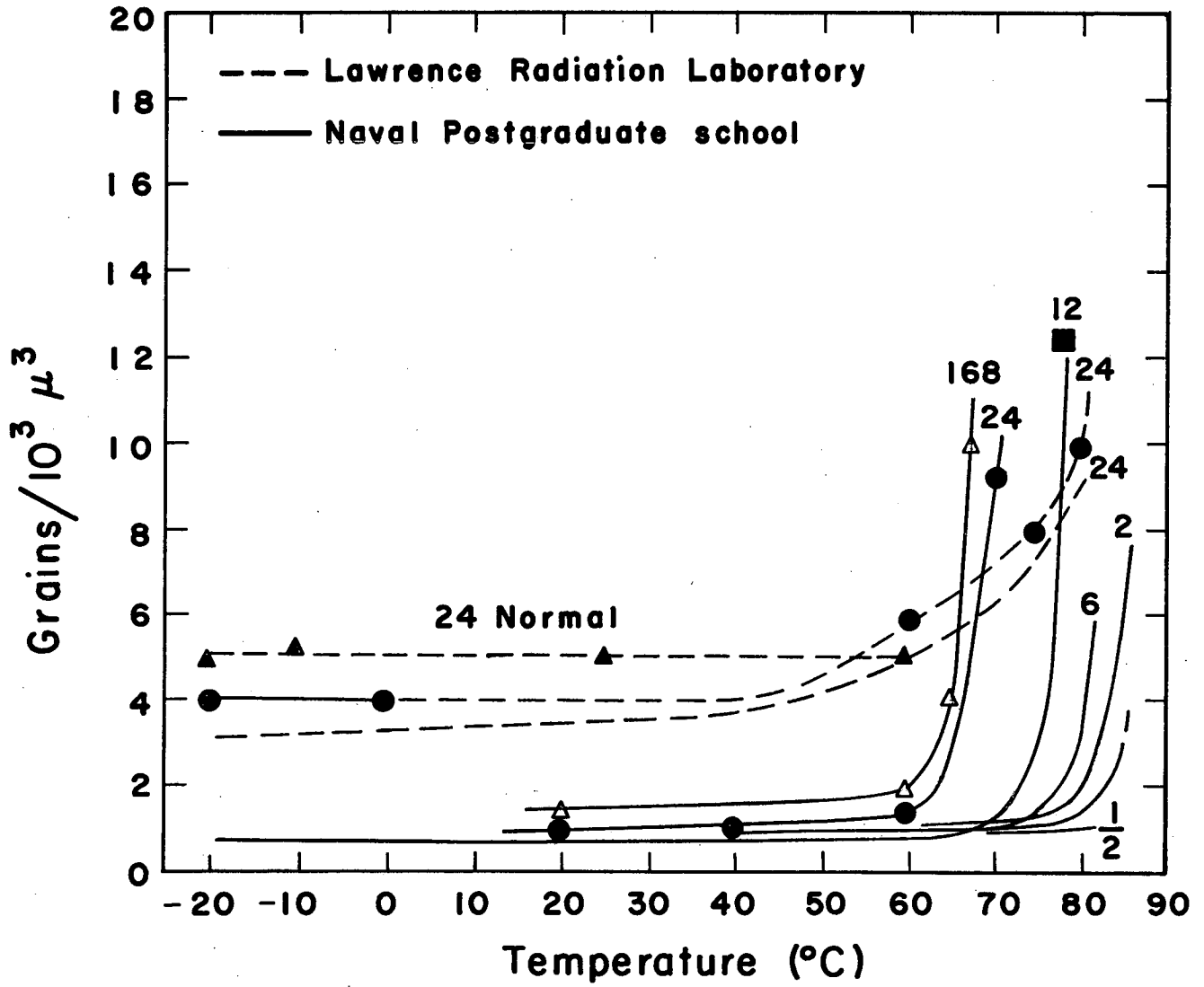

MUB 13940

Fig. 3

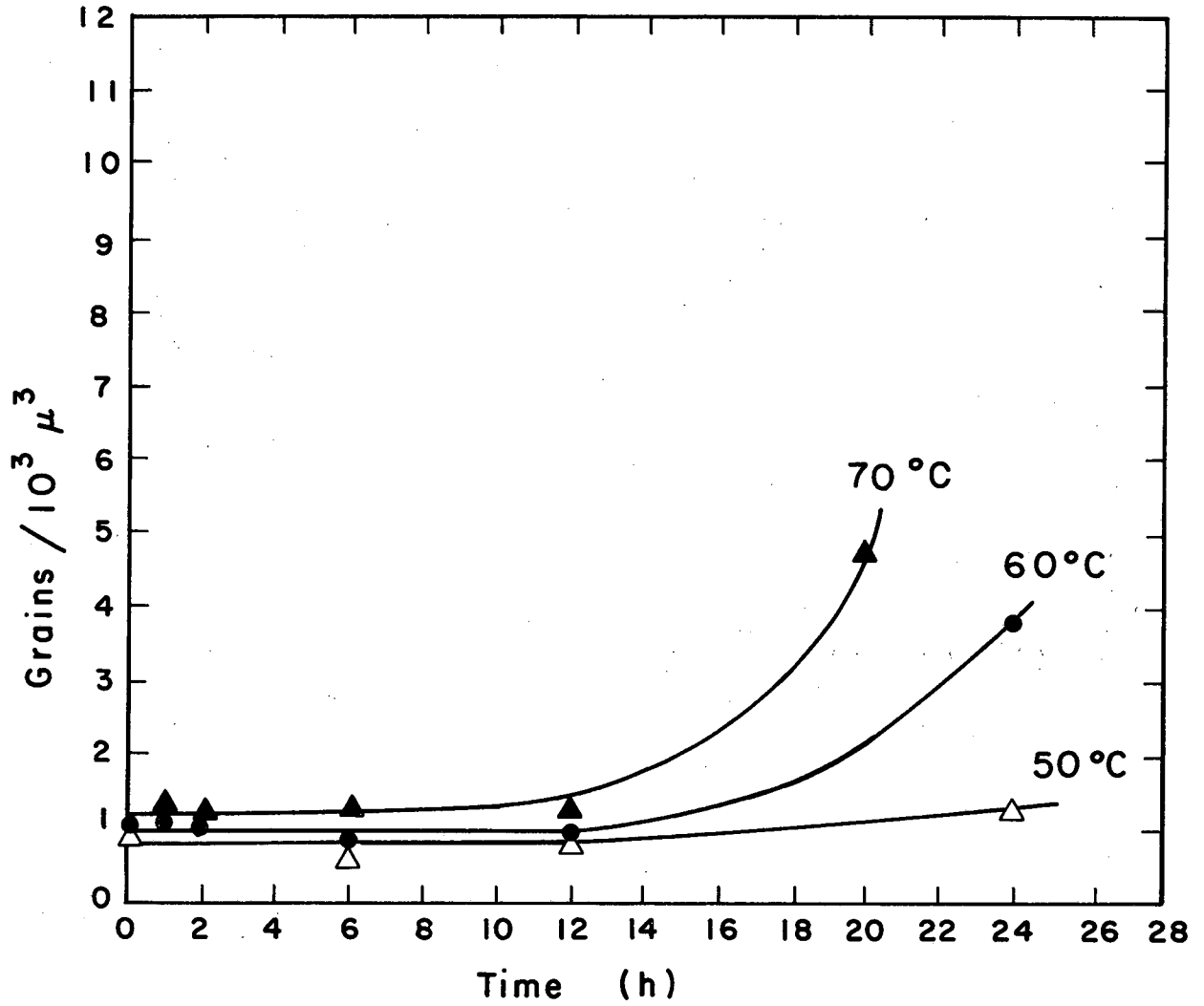

MUB 13930

Fig. 4

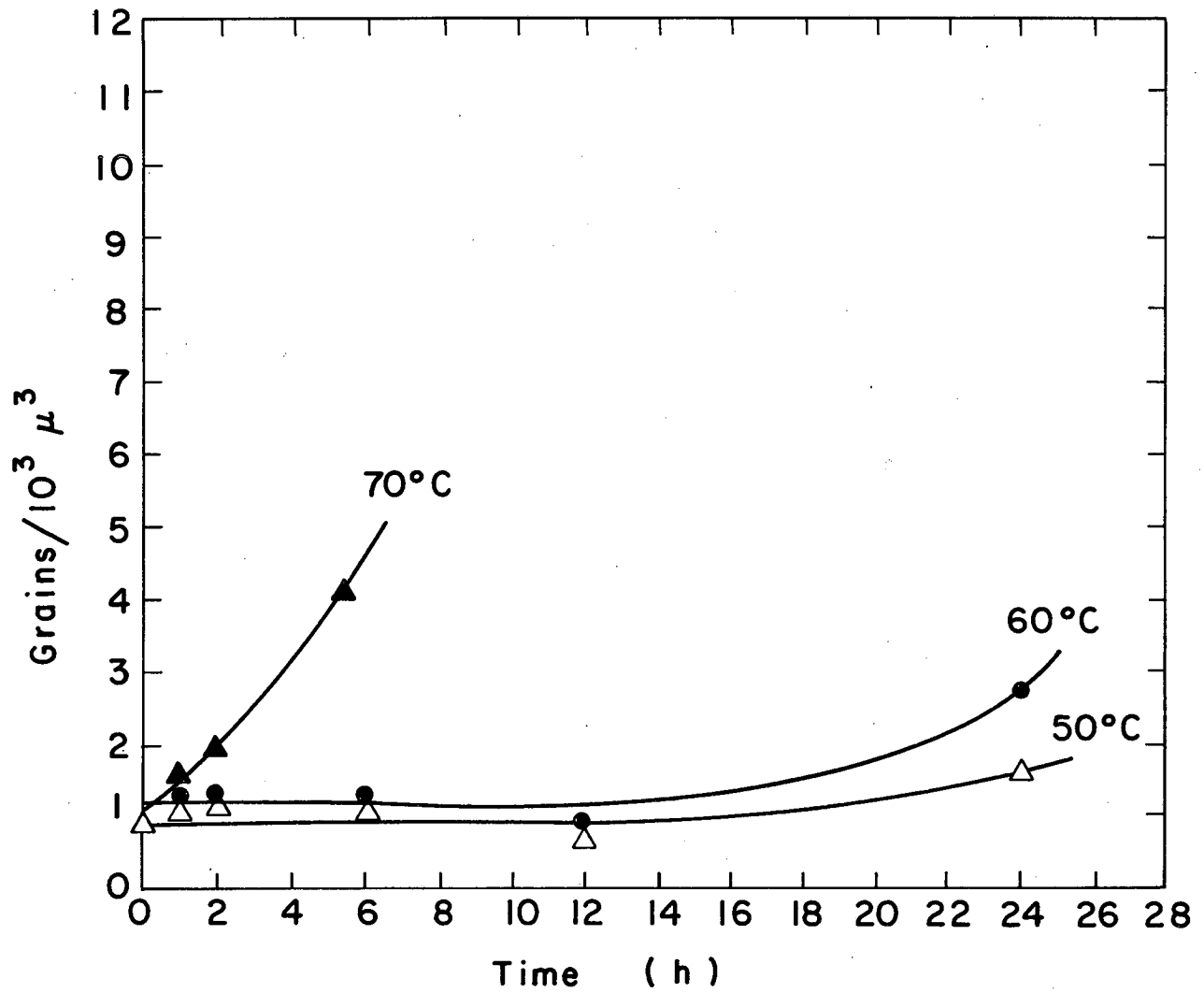

MUB-13934

Fig. 5

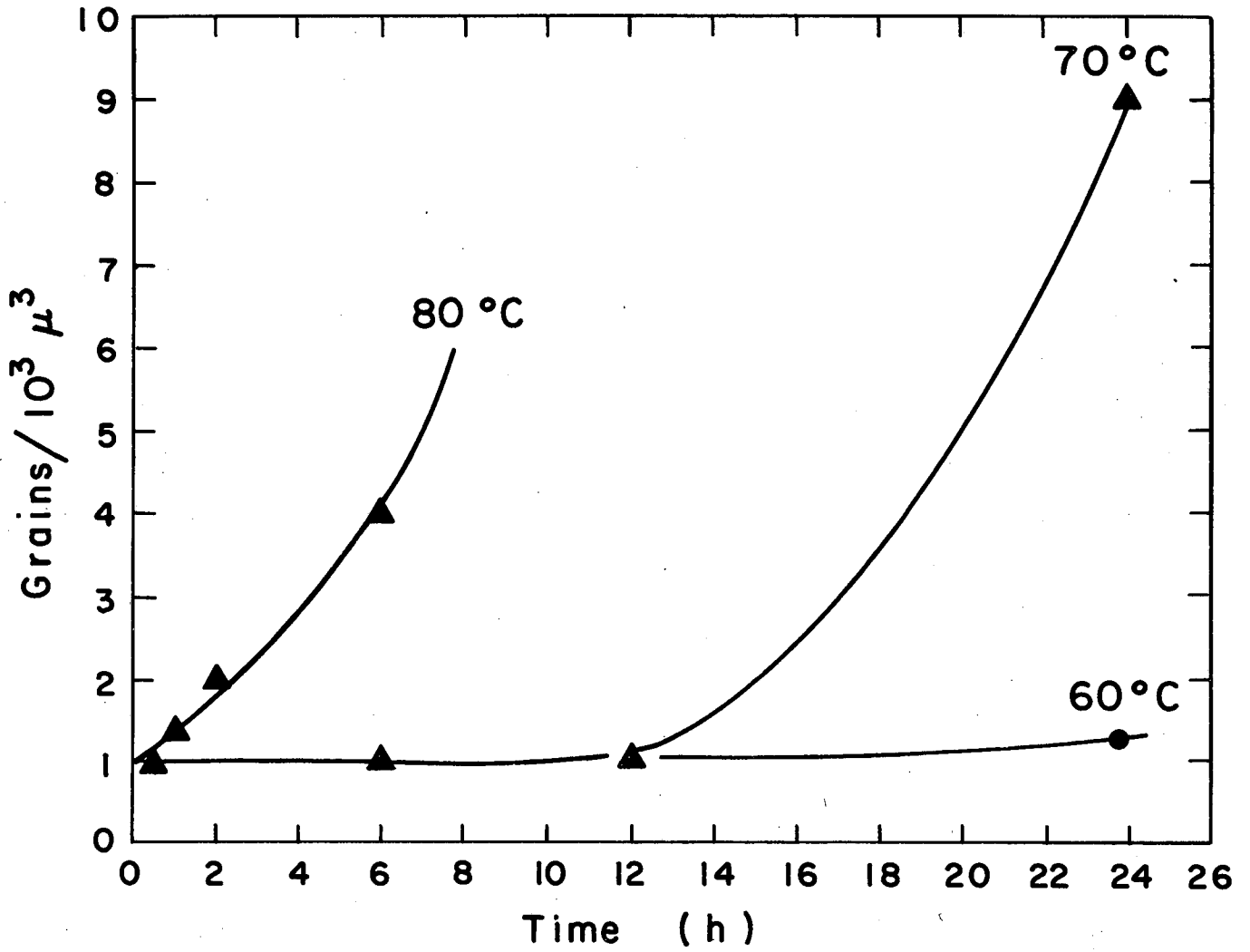

MUB-13931

Fig. 6

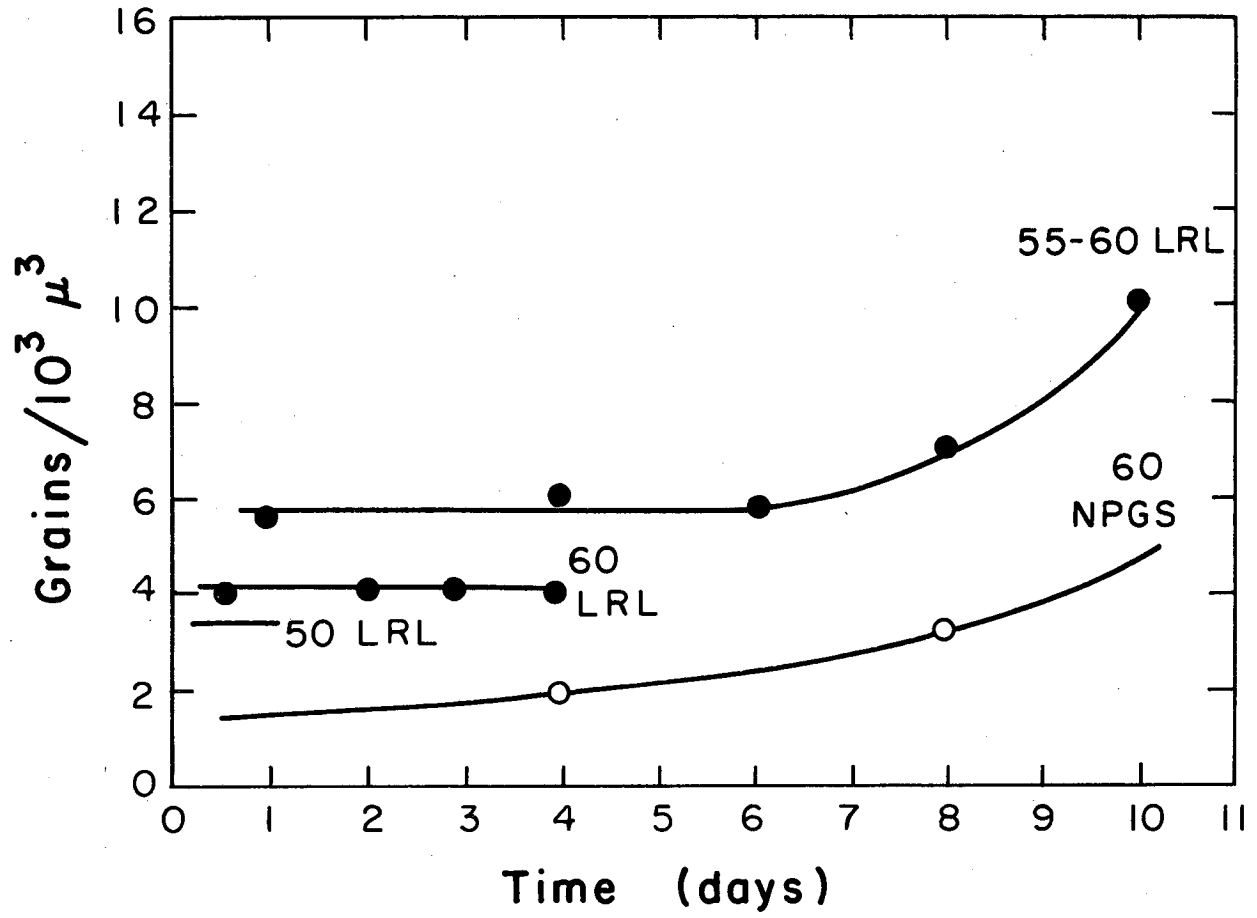

MUB-13932

Fig. 7

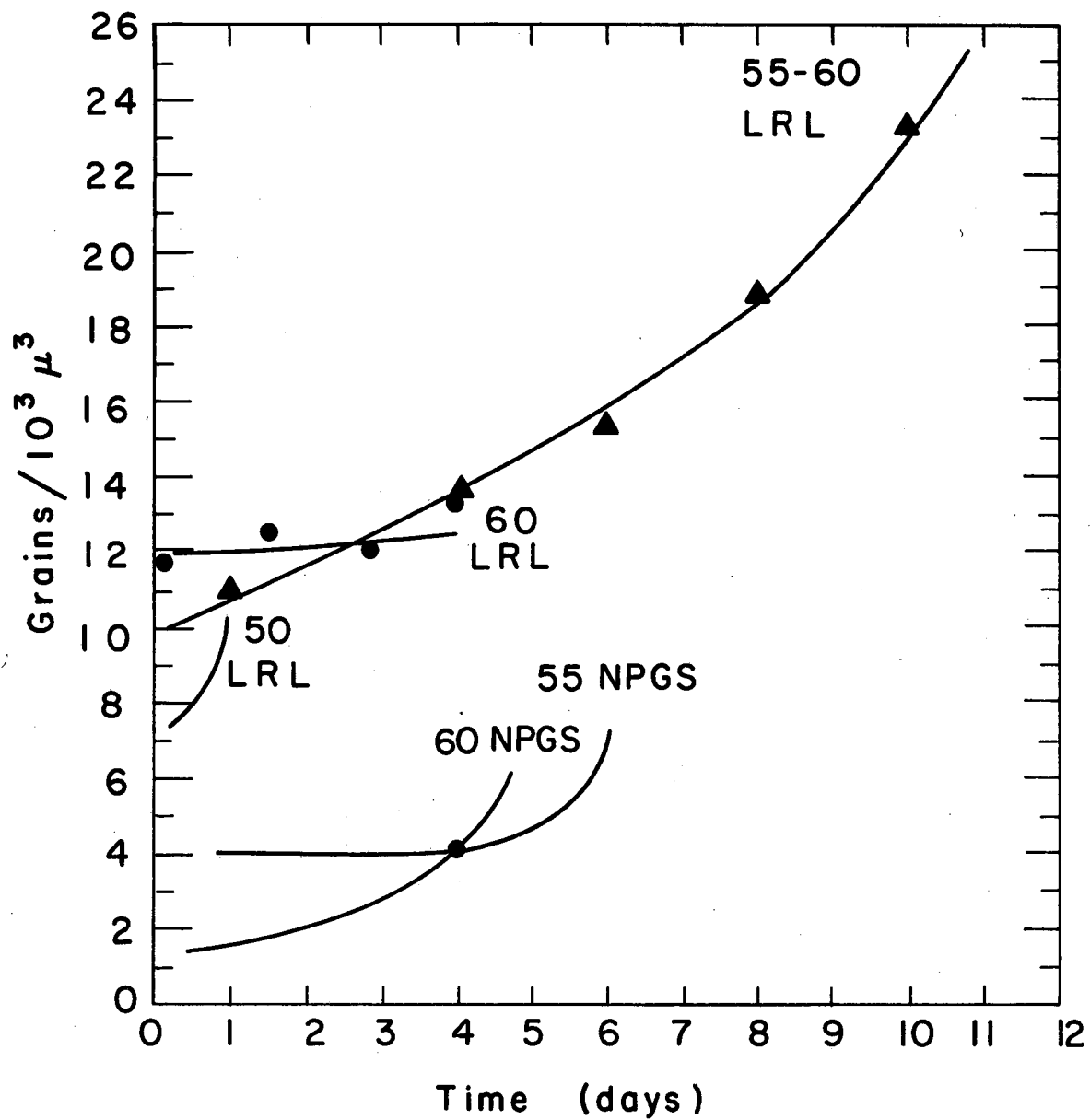

MUB-13938

Fig. 8

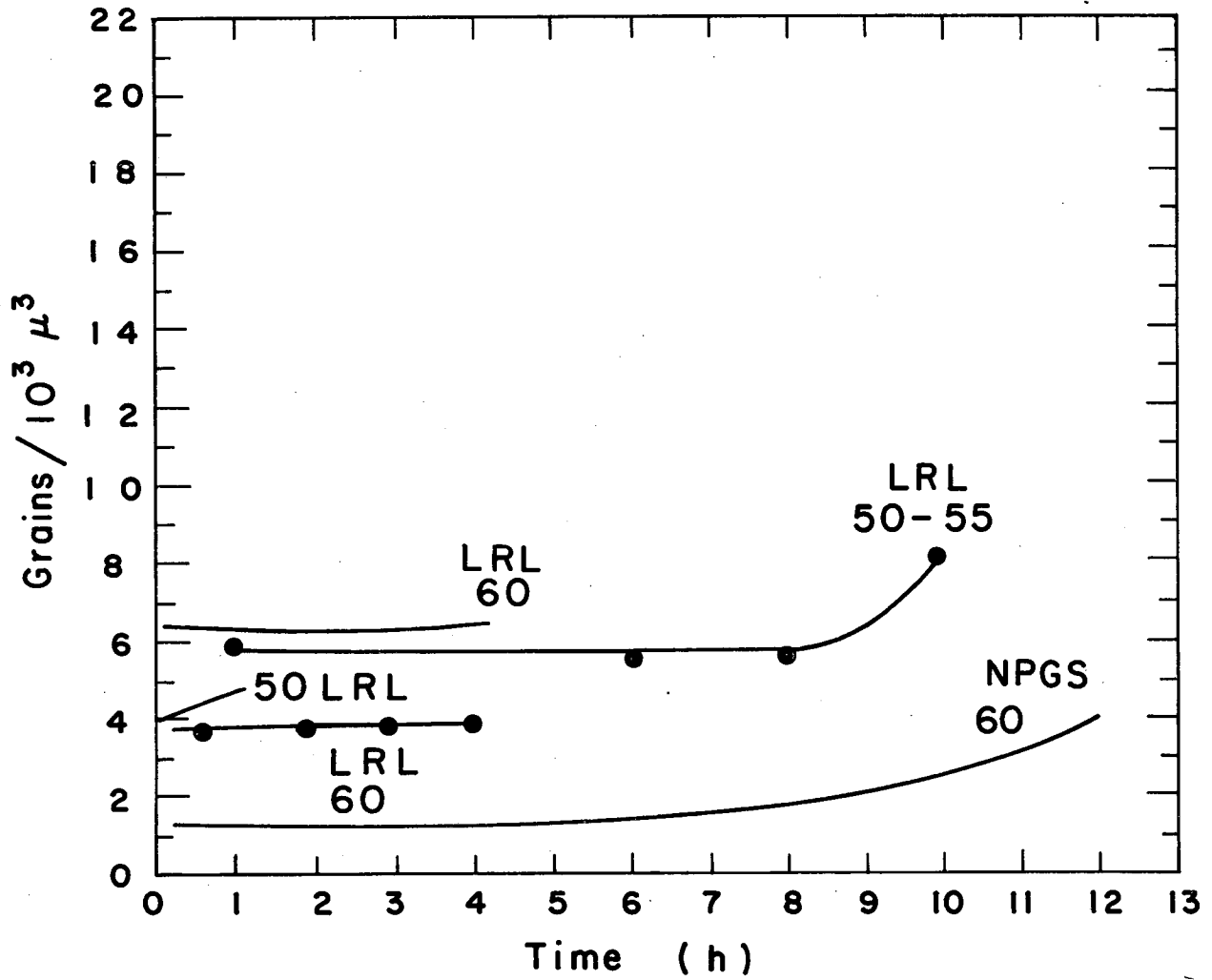

MUB-13941

Fig. 9

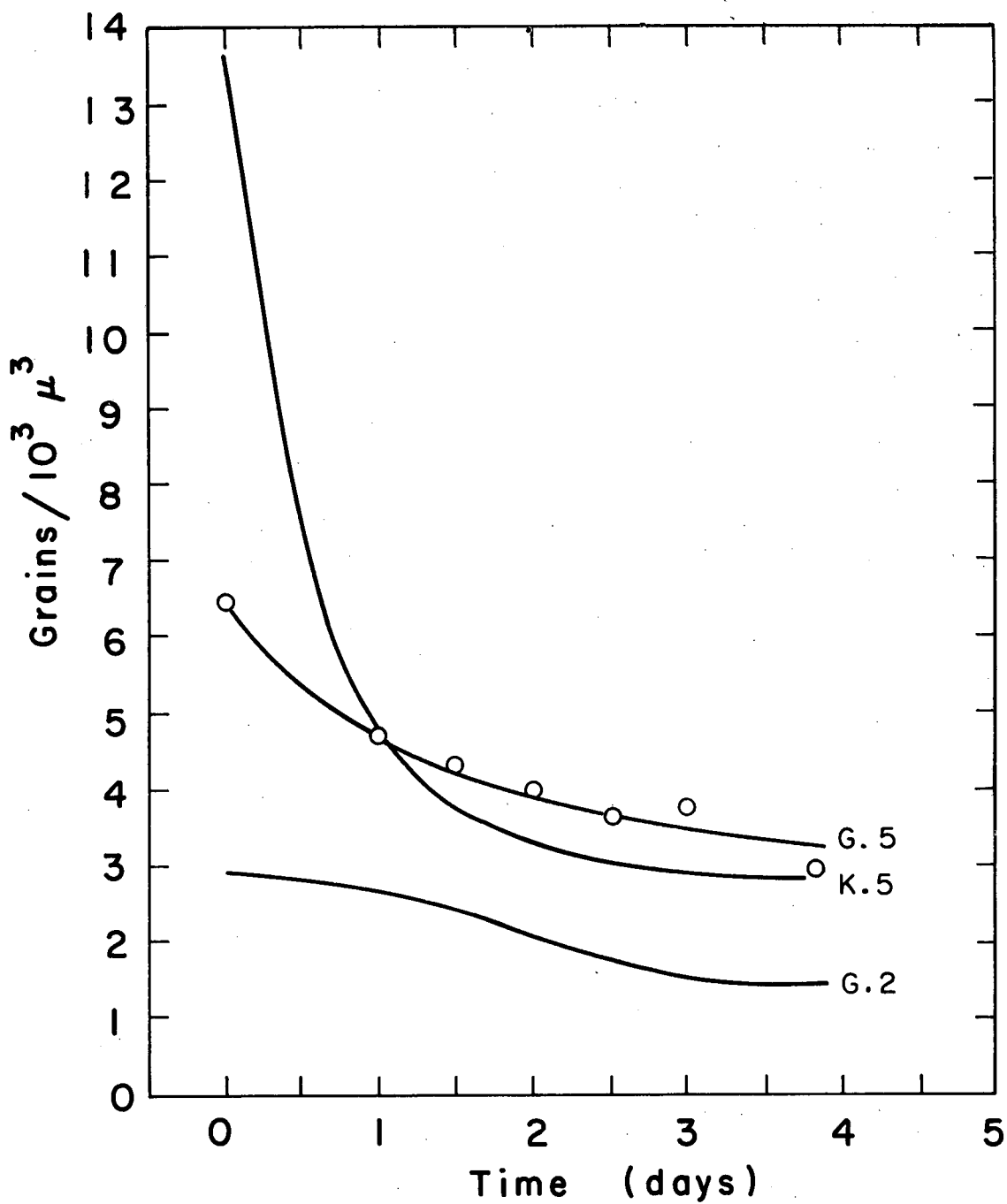

MUB-13937

Fig. 10

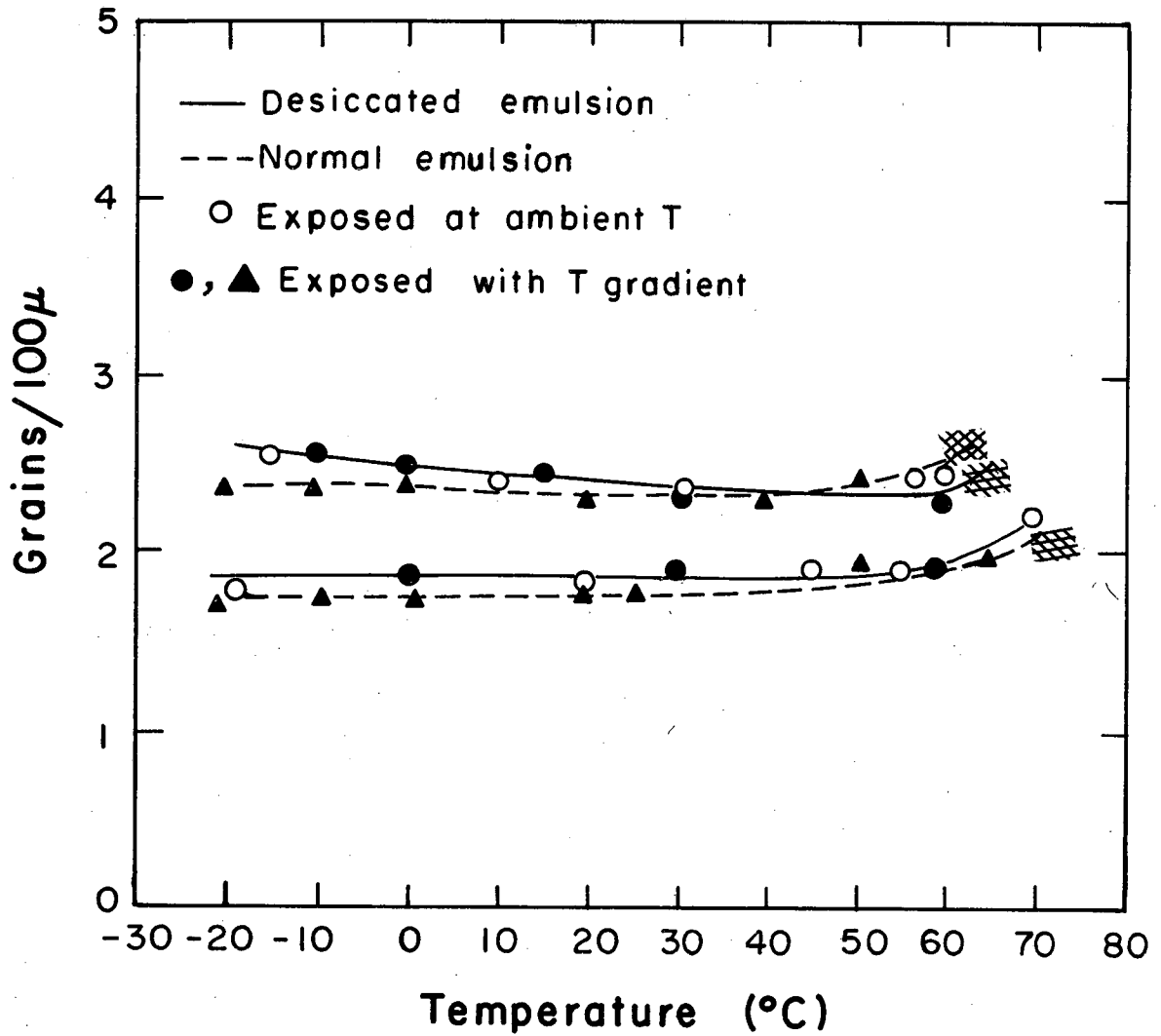

MUB-13935

Fig. 11

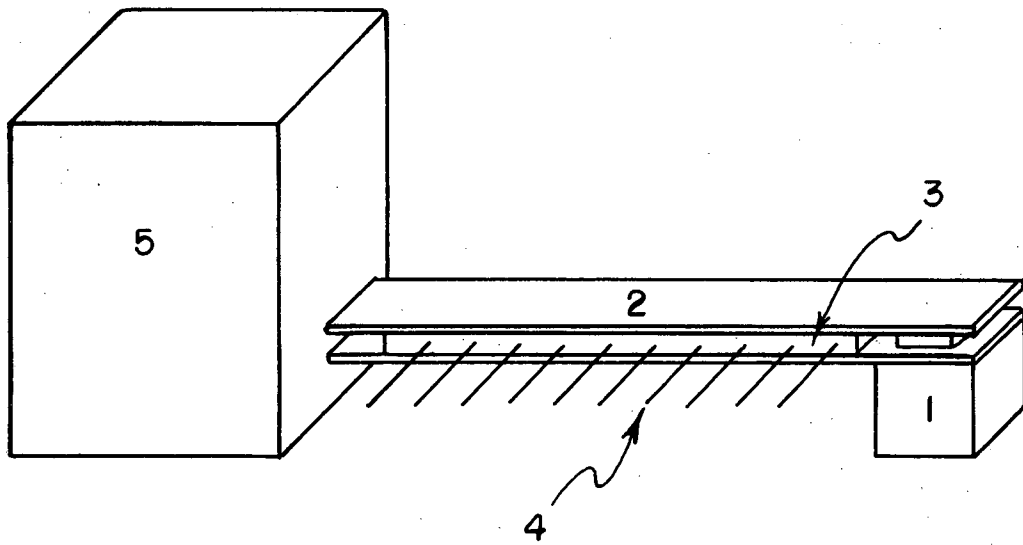

MUB-13939

Fig. 12

This report was prepared as an account of Government sponsored work. Neither the United States, nor the Commission, nor any person acting on behalf of the Commission:

- A. Makes any warranty or representation, expressed or implied, with respect to the accuracy, completeness, or usefulness of the information contained in this report, or that the use of any information, apparatus, method, or process disclosed in this report may not infringe privately owned rights; or
- B. Assumes any liabilities with respect to the use of, or for damages resulting from the use of any information, apparatus, method, or process disclosed in this report.

As used in the above, "person acting on behalf of the Commission" includes any employee or contractor of the Commission, or employee of such contractor, to the extent that such employee or contractor of the Commission, or employee of such contractor prepares, disseminates, or provides access to, any information pursuant to his employment or contract with the Commission, or his employment with such contractor.

