

UCLA
Contemporary Music Score Collection

Title

Rude Food

Permalink

<https://escholarship.org/uc/item/5bt770w8>

Author

Reyes, Alexander

Publication Date

2020

Three Arias from

Rude food

I. The Perfect Start

II. Strict Pasta

III. The Banana and Other Splits

Performance notes:

The single line staff indicates a sung pitch within the middle of the performer's range. Bar lines represent approximate five second intervals. The lines drawn above and below indicate the pitches to be performed, as well as the duration of each event.

Words appearing in boxes on the staff should be approached as spoken, shouted, or whispered in accordance with any directions written above. Additionally, the various fonts, capitalizations, and other visual manipulations of the text can be interpreted as dynamics, accents, and other parameters.

The numbered events at the end of movement three are to be mimed by the performer.

Theatrical interpretation is encouraged.

The Perfect Start

Rapid mumbling
(nearly inaudible)

long moist tender faintly embarrassing

Sung

long,

moist,

ten - der,

faint - ly - em - bar - rass - ing

Spoken

ASPARAGUS

Rapid Mumbling
(Crescendo)

long moist tender faintly embarrassing

Sung

care - ful - ly

pre - pared

ASPARAGUS

Eat - en with sin - gers

Served Raw

long,

As - par - A - zus

moist,

As - par - A - zus

ten

der,

As - par - A - zus

Boiling
Passionately

longmoist tender. Slightly embarrassing long

As

par

aPar

Aspara

para

Aspar



aParas

paragus

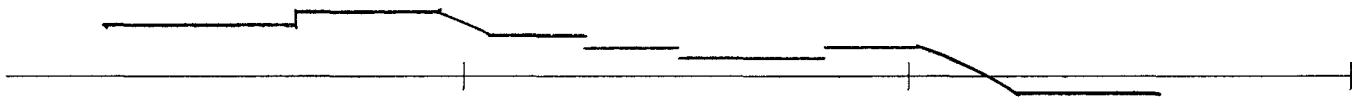
ASPARAGUS

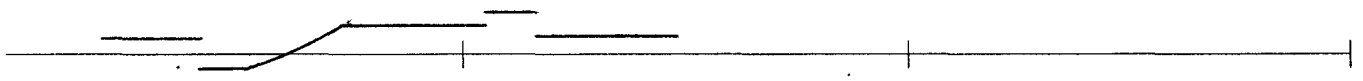
[faint] — [ly] [em-bar] — [lass] — [ing]

[Kate] - [sul] - [ly] [pre-] [pared] [Eat] - [en]

[w/] [sin] — [gers]
[Served] [BAW]

Strict Pasta.

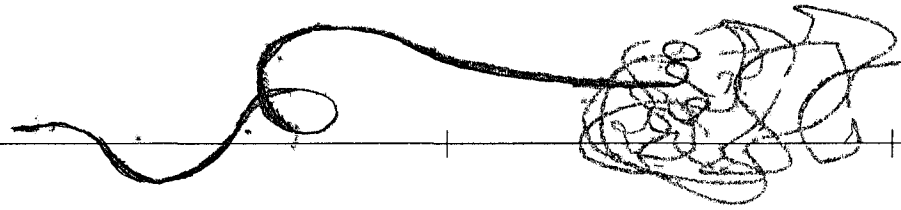

PA 1

STA!

Firm.

Plump.

Firm.

Plump,

Slip

ry

be - tween

the

~~light~~

plump

firm

plump

whisper

Subtle taste

Firm. PLUMP. FIAM. Slip ~~per~~ per

-y be - tween your teeth

Rhythmically

p m p m s be - tween the lips...

f m m p p m p f Drain Well

PA Sta

The Banana & Other Splits

A Jaunty Banana

long Two Halves

round a dol-lop of cream

the Split

Vamp
||: x x x x x x x x x x :||
B A N A N A N A N A Ba... Long

...Na...

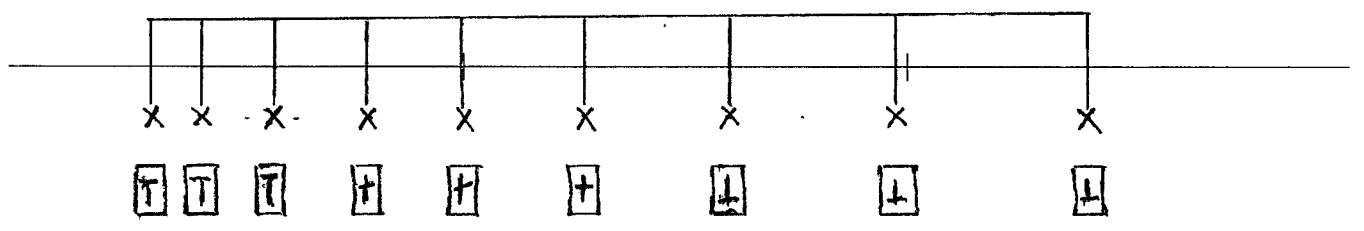
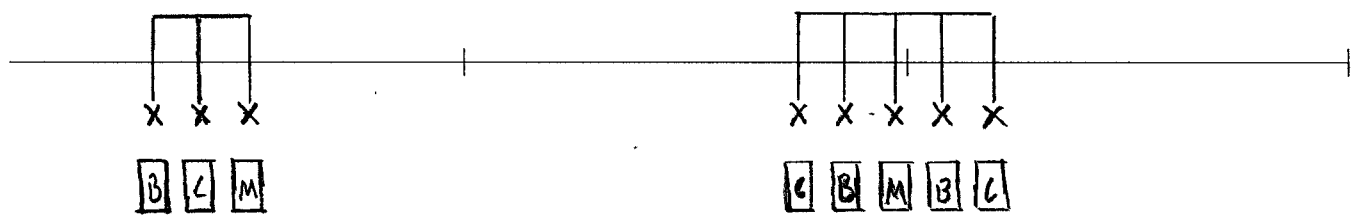
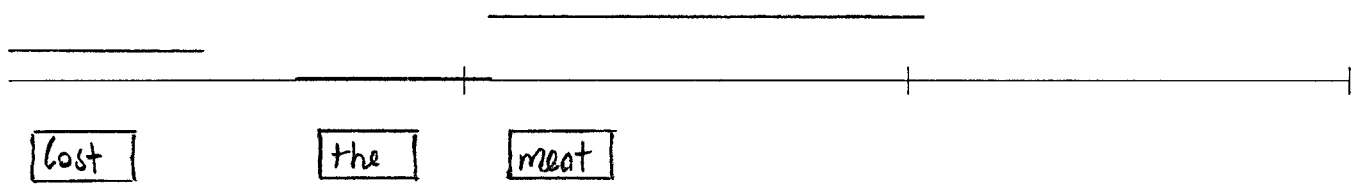
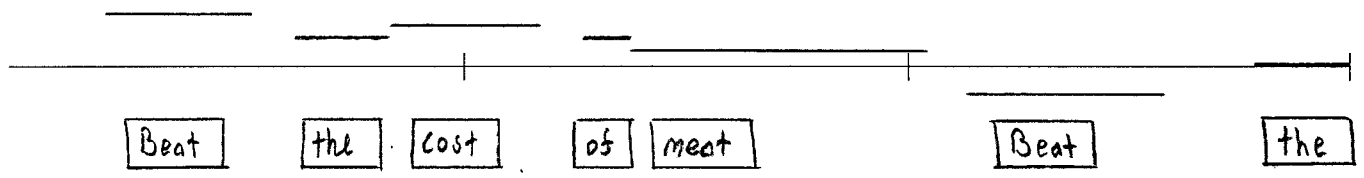
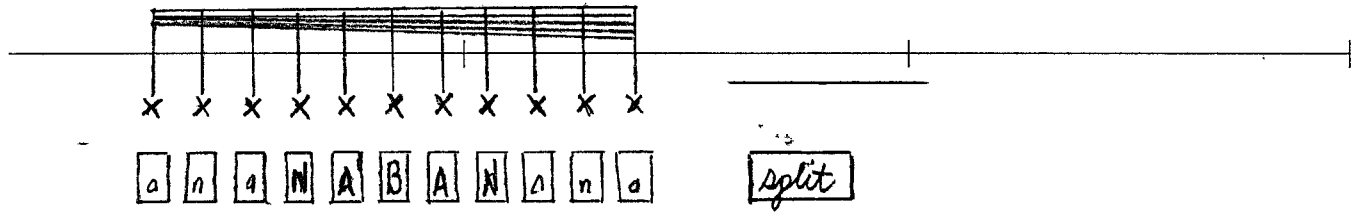

1 Jaunty Banana

Split

Two

Halves

4 dol - lop

os

Cream

Two Round
One Long

Round

Round

Lo
ng

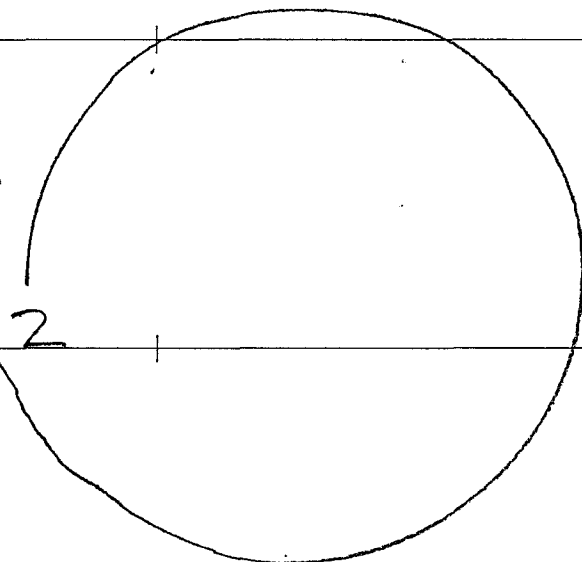
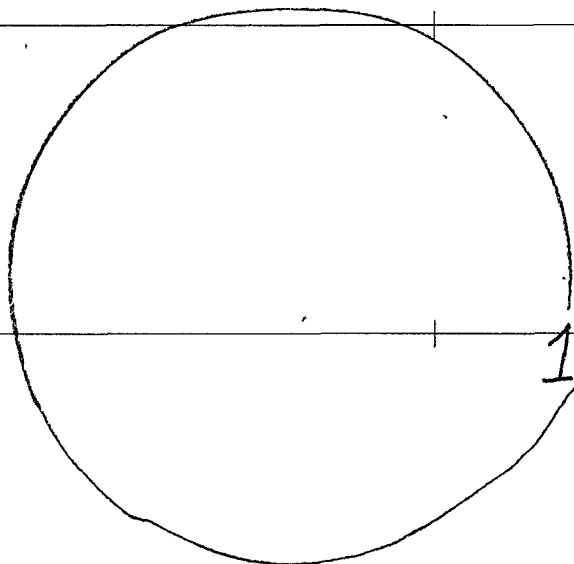

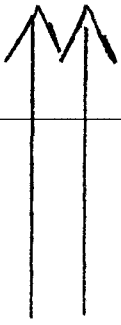

3

