



Six Flags over Luna: The Role of Flags in Moon Landing Conspiracy Theories

Anne M. Platoff

Abstract

According to historians, twelve American astronauts explored the surface of the Moon between 1969 and 1972. During their time on the lunar surface each Apollo crew deployed a special flag pole, leaving a total of six American flags on the surface of the Moon. Or did they? Since the 1970s conspiracy theories have emerged which claim that the National Aeronautics and Space Administration (NASA) faked the moon landings. Much of the evidence used by the conspiracy theorists consists of photographs and films released by NASA during the Apollo Program. Not surprisingly, the flags have played a major role in the argument that the moon landings were an elaborate hoax. This paper will examine the claims of the conspiracy theorists, especially those related to flags, and will provide explanations in support of the historical reality of the Apollo missions.



Apollo 14 commander Alan B. Shepard, Jr. with the flag on the Moon

Six Flags over Luna: The Role of Flags in Moon Landing Conspiracy Theories

The Apollo Program

The iconography of exploration has long been linked with flags. When depicting explorers, we usually show them with flags, whether they are landing on a new shore, celebrating their ascent to the summit of a great mountain, or arriving at one of the planetary poles. Perhaps the most iconic exploration images of the twentieth century were the photographs produced as part of the Apollo Program of the National Aeronautics and Space Administration (NASA). Born of the “Space Race” between the United States and the Soviet Union, the goal of Apollo was to send humans to the Moon to explore the surface and return lunar samples to Earth for study. During Apollo, the U.S. sent nine 3-man crews to the Moon. Six of these missions included landing astronauts on the lunar surface. Like other great explorers in history, the Apollo astronauts carried souvenir flags with them and also planted flags at their destinations.

During the Apollo Program, six 2-man crews descended to the surface using the lunar module (LM) spacecraft. Each mission built upon the previous one, increasing the time the spacecraft was on the surface and the amount of time spent in extravehicular activity (known by the NASA acronym EVA, or colloquially as “moonwalks”). While the Apollo 11 crew spent only 21 hours and 36 minutes on the surface, and was limited to an EVA of 2 hours and 31 minutes, the crew of Apollo 17 accrued 3 days, 2 hours, and 59 minutes on the surface and 22 hours and 3 minutes of EVA time during three moonwalks. Throughout their time on the Moon, the Apollo astronauts deployed a variety of experiments, collected 842 pounds (382 kilograms) of lunar surface samples, and—of special interest to vexillologists—deployed six flags on the surface.¹

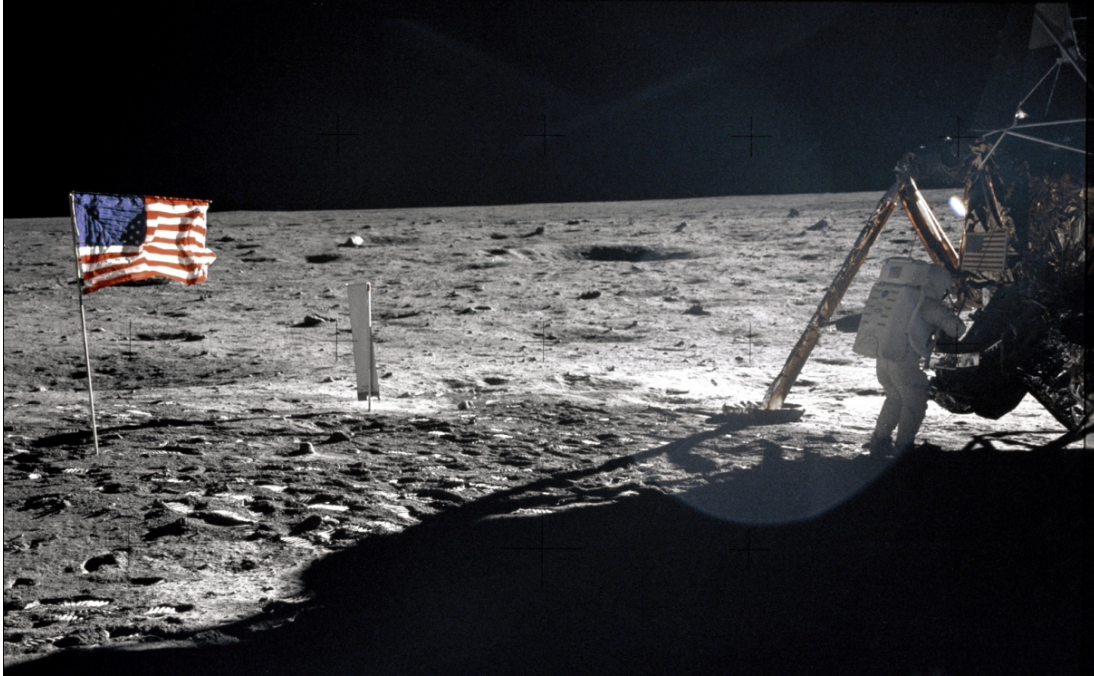
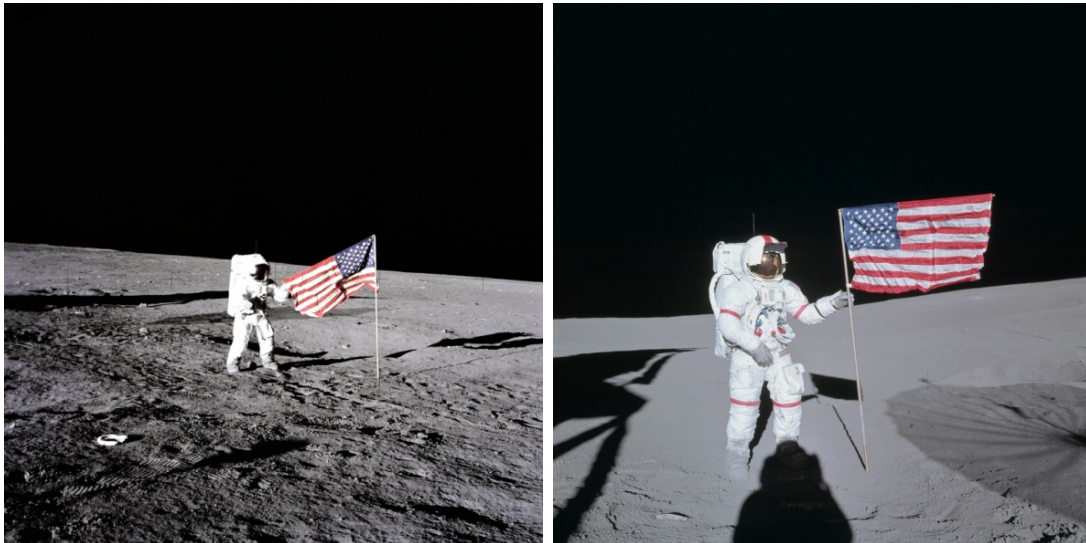
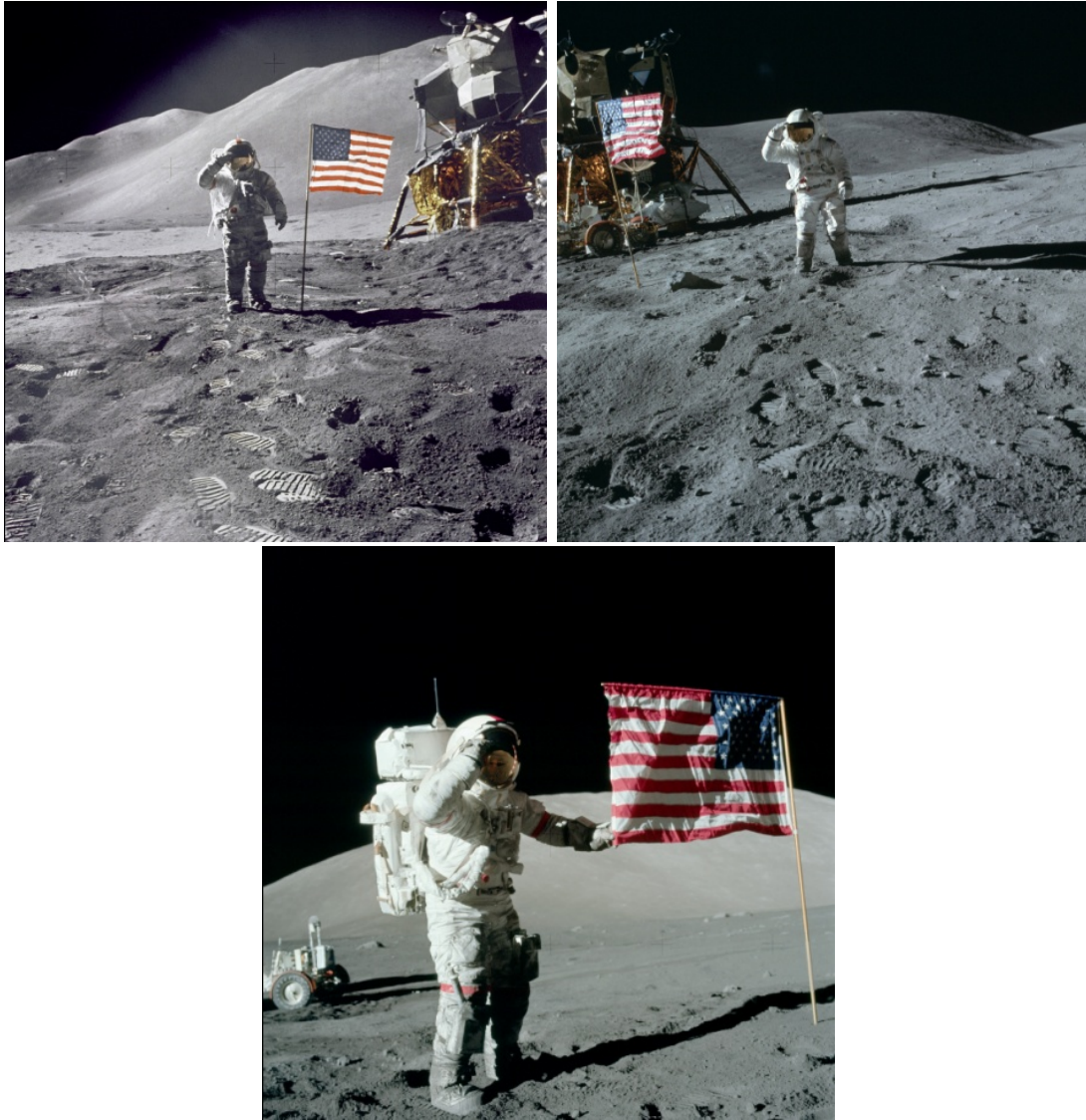


Figure 1: This image, which shows both the first man to walk on the Moon and the first flag planted there, is one of the few still photographs taken of Neil Armstrong during the Apollo 11 mission (NASA Photo AS11-40-5886).



Figures 2–3: Apollo 12 commander Astronaut Charles Conrad, Jr. (left) and Apollo 14 commander Alan B. Shepard, Jr. (right) with the flags left on the Moon during those missions. (NASA Photos AS12-47-6897 and AS14-66-9231)



Figures 4–6: Apollo 15 commander Astronaut David R. Scott (top left), Apollo 16 astronaut Charles M. Duke, Jr. (top right), and Apollo 17 commander Eugene A. Cernan (bottom) pose with the flags from those missions. (NASA Photos AS15-88-11863, AS16-113-18341, and AS17-134-20386)

In 1992, I presented a paper to my fellow vexillologists at NAVA 26 entitled “Where No Flag Has Gone Before: Political and Technical Aspects of Placing a Flag on the Moon”. As I explained in that paper, the planting of the U.S. flag on the Moon did not indicate a territorial claim—the United Nations Outer Space Treaty of 1967 clearly prevented one nation from claiming the Moon. Instead, the flag was a symbol of human achievement in the exploration of space. My paper described the political debate over whether or not flags should be left on the surface, and which flags would be included in the missions. It also documented the technical process of designing the lunar flag assembly—a special flagpole designed by NASA engineers to display the flags on a planetary body which, due to its tenuous atmosphere, does not have any wind. At the time I presented this paper, I took it for granted that everyone accepted the Apollo

moon landings as historical fact. However, in later years I discovered that my paper had been cited by historians and other space advocates as a source in defense of the validity of the Apollo Program. Having grown up with the Apollo Program, I was surprised to find out that there are people who believe that it never happened. In the process of doing research for this paper, I have also found my lunar flag assembly history cited by some of the conspiracy theorists. This has motivated me to take a serious look at their claims about flags on the Moon.²

Introduction to Moon Landing Hoax Conspiracy Theories

As with many conspiracy theories, there is no one unified theory called the “Moon Landing Hoax Conspiracy Theory”. Instead, there are a variety of conspiracy theorists, each with their own theories and body of evidence. They have built upon each other’s ideas, however, so that there is a basic set of claims that define most moon landing hoax conspiracy theories. As best as I have been able to determine, the first book published on the topic was Bill Kaysing’s self-published book, entitled *We Never Went to the Moon*. The book was originally published in 1974, and then later expanded and republished in various editions. Examination of the book reveals it to be anything but a scholarly source. The claims made by Kaysing are presented in a disjointed manner with very little actual evidence or analysis, and his source notes are impossible to trace back to valid sources. Kaysing’s basic premise is that, at some point, NASA officials determined that the agency was incapable of successfully landing astronauts on the surface of the Moon and returning them safely to Earth. Therefore, he claims, the agency undertook an elaborate hoax to fabricate false evidence of moon landings in order to make it look as if they had been successful. Kaysing presents his credentials stating that he had worked as an engineer for Rocketdyne, one of the NASA contractors involved in making rocket engines. In fact, he was actually a technical writer and head of technical publications at Rocketdyne, and was not trained as an engineer or scientist. It is also important to note that Kaysing’s employment with Rocketdyne started in 1956 and ended in 1963, just two years after President John F. Kennedy’s famous “Moon” speech and six years before the first Apollo moon landing.³

In various versions of his book, Kaysing repeats several points of evidence in support of his theory. Much, but not all, of his evidence has been derived from NASA photographs which Kaysing says were created on a soundstage, rather than on the surface of the Moon. First, he cites the lack of blast craters under the engine of the lunar modules. He mentions that artist’s conceptions painted before the missions portrayed craters underneath the LM engines. He also claims that a lack of dust on the landing pads of the LM clearly indicates that the images are faked, as it was a common belief that there would be a thick layer of dust on the lunar surface. In addition, he shows several photographs which he says prove that there were multiple light sources in a studio, instead of illumination from sunlight. Finally, he points out that no stars are visible in the photographs, claiming that without an atmosphere to filter out starlight they should have been clearly visible. Throughout the rest of the book, these main themes are repeated over and over again. Kaysing suggests that the fraudulent still photos and videos were filmed at a

secret U.S. military facility outside of Las Vegas, Nevada, perhaps with the assistance of Hollywood special effects artists. He also ties the deaths of various astronauts to NASA's attempts to silence any would-be whistle-blowers. In his books, Kaysing does not mention the flag in his body of evidence. However, in interviews recorded later he does include the fact that the flag is "blowing in a breeze" as further evidence that the images had been faked.⁴

The basic claims made by Kaysing have been repeated and expanded by a variety of other conspiracy theorists. One such author is Ralph René, who wrote a book called *NASA Mooned America!* René describes himself as a "former member of MENSA with an IQ in the top 1/2% of the population". He also notes that he is the holder of two patents and a "self-trained engineer". He further cites that his "lack of academic credentials caused [his] manuscript to be ignored by most publishers". As for the claims made in his book, they echo the basic tenets presented by Kaysing with the same type of photographic evidence. A more professionally-published book by David Percy and Mary Bennett is called *Dark Moon: Apollo and the Whistle-Blowers*, released in 1999. Percy, a British photographer, uses a wide variety of lunar photographs and frames from NASA videos to demonstrate his claims that the moon landing images are faked. However, as the reader wades into this somewhat daunting tome they quickly discover that the authors assign different motives to the conspiracy than those suggested by Kaysing and René. Bennett and Percy do not deny that astronauts may have gone to the Moon. Instead, they suggest that the Apollo Program portrayed to the public by NASA was a cover-up for the "real" top-secret moon landings conducted by crews of unnamed astronauts. They further suggest that there are connections between the moon landing hoax and extraterrestrials, crop glyphs, and alien artifacts on Mars. They claim that the purported inconsistencies in the NASA photographic record were created by "whistle-blowers" within the agency in order to help later investigators discover evidence of the hoax. Belief in moon landing hoax theories is not limited to English-speaking countries, of course. For example, there are several Russian hoax theorists who have published books in Russian on the topic. The first is Aleksandr Popov, a physicist and mathematician. His book title translates as *Americans on the Moon: Great Breakthrough or Cosmic Swindle*, and repeats the same type of claims found in the English-language books. Another Russian hoax theory proponent is Yuri Mukhin, author of a book (title translated) called *Anti-Apollo: Lunar Affair of the USA*. He makes the additional claim that the Soviet Communist Party's Central Committee and some Soviet scientists aided NASA with faking the moon landings.⁵

Many of the hoax theory proponents have made their cases via amateurish videos offered for sale on the Internet or posted on *YouTube*. Examples include a video entitled "We Never Went to the Moon," directed and produced by Daryl Carstensen and Ross Marshall. This video is actually a compilation of several interviews with Bill Kaysing, in which he states his reasons for why he believes that the moon landings were faked. Another is "Dark Mission 1—NASA Moon Hoax," a video which was found on *YouTube*. This video presents not only Kaysing's claims, but also those of David Percy. One of the more confusing videos is "Did We Go?",

directed and produced by Aron Ranen. In the video he contends that he is trying to determine whether or not men have visited the Moon. He visits sites connected to Apollo and interviews many people who worked in the space program. However, he goes off on tangents such as obsessing about Wernher von Braun's Nazi past and interviewing people in Neil Armstrong's home town about Armstrong's character. He speaks to the last man who saw the Apollo 11 astronauts before the spacecraft hatch was closed and says "I believe him". He goes to an observatory where they bounce a laser off a reflector left on the surface of the Moon, and he talks to a scientist at the California Institute of Technology who verifies that the moon rocks "are not from the Earth". After this, he speaks to a Navy diver who watched the space capsule splash down and opened the hatch to help the astronauts exit their spacecraft. Finally, he talks to astronaut Gene Cernan, who tells him that "there weren't any stage hands on the Moon when I was there". In the end of the video, however, Ranen declares that he "can't absolutely prove that we went there".⁶

Even with the books and videos in circulation, though, for decades very few people were actually exposed to the moon landing hoax conspiracy theories. The claims mostly circulated among the community of conspiracy theorists and others who generally distrust that the United States government ever tells the truth about anything. Occasionally a story based on one of the theories appeared in a supermarket tabloid—the type that regularly report on celebrity scandals, UFO sightings, alien abductions, and cryptozoological creatures. It wasn't until 2001 that the idea that the moon landings were faked was presented to a large-scale audience through the medium of television. Directed by John Moffet and narrated by *X-Files* actor Mitch Pileggi, the documentary "Conspiracy Theory: Did We Land on the Moon?" aired on the American Fox television network in February 2001. It is estimated that 15 million viewers watched the show. Though presented in a documentary format and claiming that it wanted the viewers to "decide for themselves", the material presented was skewed in favor of the conspiracy theorists and only included token responses from a NASA public affairs spokesman. There was no real attempt by the producers to include a scientific or scholarly appraisal of the conspiracy theories and their validity, or lack thereof, in the show.⁷

The Conspiracy Theory and Public Opinion

In the introduction to Bill Kaysing's book, it states "It has been estimated that about 30 per cent of the adult population of the United States does not believe that this country has landed astronauts on the moon". However, since the origin of this particular estimate is not cited in the book, it is impossible to trace it back to an original source. In fact, it is difficult to determine just how many people in the United States seriously believe that their government faked the Apollo moon landing missions. Most polls have shown the number of hoax believers to be significantly lower than the figure cited by the conspiracy theorists. A telephone poll conducted in the U.S. by Time/CNN in July 1995 revealed that only 6% of those surveyed believed that the Apollo moon landings were a hoax, with 83% saying they had been real, and 11% saying that they

weren't sure. A Gallup Poll conducted by telephone in the U.S. in July 1999 showed similar results—6% believed the moon landings were faked, 89% believed they had really occurred, and 5% offered no opinion. A more recent poll, this time conducted in the U.S. via telephone and the web, showed a slight variation between people polled through the two methods. Of those polled online, 91% believed that the moon landings had occurred, 3% thought they were a hoax, and 6% were not sure. For those polled by phone, 87% agreed that they were real, 7% believed that they had been faked, and 4% were unsure. However, in the Fox television special, “Conspiracy Theory: Did We Land on the Moon?”, it was suggested that the number of believers was higher and that 20% of Americans believed that we have never gone to the Moon. The producers, however, did not cite any polls as a basis for their estimate.⁸

Polls in other countries have shown higher numbers of believers than those in the United States. For example, a survey conducted in Russia by the Public Opinion Fund in 2000 found that 16% of respondents were not even aware that the United States had landed a man on the Moon in 1969. When asked if they believed the moon landing had actually occurred, 51% of all those polled said “yes”, 28% said “no”, and 22% indicated that they found it difficult to answer. The percentage of non-believers was higher among those who were not aware of the moon landing (41%) than among those who were aware of it (23%). An article in *Engineering & Technology*, published in 2009, reported that a poll in Britain had revealed that one in four of those polled did not believe that the Apollo 11 moon landing was real. An online survey posted by the German news magazine *Der Spiegel* asked readers if the first moon landing had taken place. When I looked at the results of the ongoing poll 39% of those who chose to answer the poll had selected one of the two options in favor of the moon landing, 47% had picked one of the two negative responses, and 14% had responded that it made no difference to them.⁹

Analyzing the Evidence

For many years, NASA basically ignored the conspiracy theories and offered virtually no official refutation of the claims that the moon landings were faked. Perhaps NASA managers believed that addressing such claims would lend credence to the hoax theory proponents. More likely, NASA management believed that the conspiracy theories were just “too silly” to be believed. The agency operates within an atmosphere where science and technology literacy are extremely high. For the people who work every day to send people into space, it is sometimes easy to forget that the average person does not necessarily have a good understanding of physics and other scientific disciplines. Moreover, it is also important to remember that the NASA establishment believes that they have consistently provided evidence of their work throughout the history of the U.S. human spaceflight program. NASA openly distributes photos and videos from all of its manned space programs. Scientists at universities around the world have been given the opportunity to analyze data from the Apollo moon landings including examination of, and scientific analysis of, the actual lunar samples returned to Earth by the astronauts. Perhaps thanks to the Fox television show, there have now been several papers and articles that finally

address the claims of the conspiracy theorists and present evidence to counter their arguments and thus, further validate the historical reality of the Apollo Program. The NASA defenders got television exposure for their arguments in 2008, when an episode of Discovery Channel's popular television program, *MythBusters*, successfully "busted" all of the conspiracy claims they examined in the show.¹⁰

Probably the best way to summarize the claims of the moon landing hoax theorists, and the explanations offered by NASA's defenders, is to examine photographs from different Apollo missions. For example, a photograph of the lunar module from Apollo 14 demonstrates one piece of evidence that is frequently cited by the conspiracy theorists. Their evidence is that photographs of the LM on the Moon do not show a blast crater on the lunar surface from the force of the spacecraft engines. This is one of Bill Kaysing's favorite arguments in support of his theory. As comparison, he likes to point out that artist's conceptions made before the Apollo missions had shown blast craters under the engines. There are several explanations for these differences besides "artistic license". First, the LM engine was not firing at full strength during the entire landing—it was throttled down during the final stage of the descent. Another reason that there is no blast crater is that the lunar surface is much more compact and solid than what was once believed. There is loose dust, but it is not as thick as was once popularly believed. This also explains why the landing pads of the spacecraft are not buried in dust, as Kaysing insists they should be.¹¹

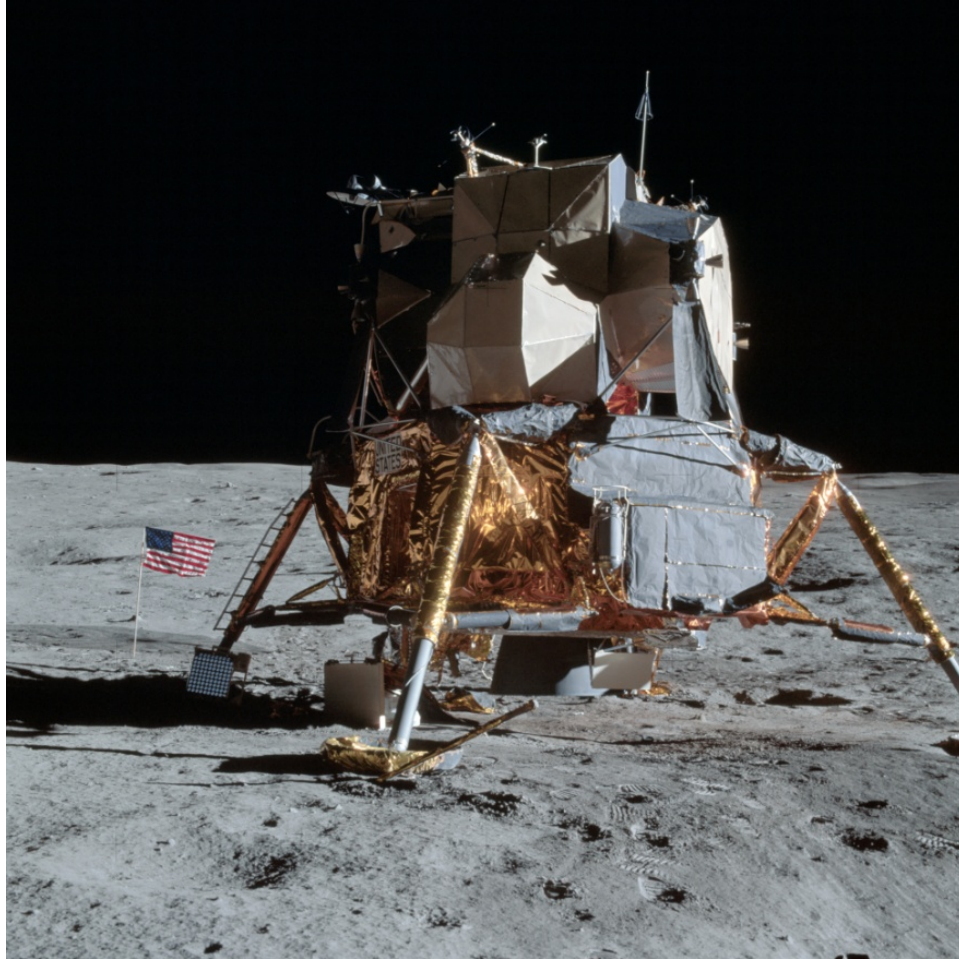
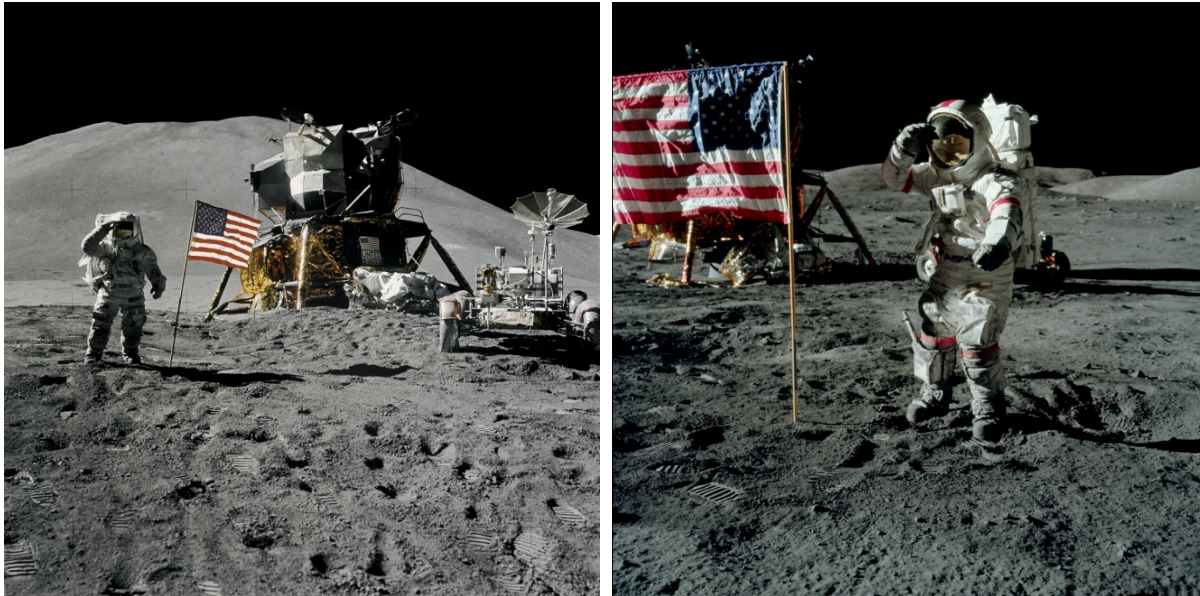


Figure 7: The deployed lunar flag assembly stands next to the Apollo 14 Lunar Module. Notice that there is not a blast crater under the engine. For conspiracy theorists this is proof that the missions were faked. NASA Photo AS14-66-9277 (5 Feb. 1971).

The next two photographs show two of the six Apollo landing sites, photographed by the astronauts during the missions. At left is an image of Apollo 15 astronaut James B. Irwin saluting as he stands next to the U.S. flag. The image at right shows Apollo 17 commander Eugene A. Cernan with the flag from that mission. In both photographs you can see the lunar modules, the lunar roving vehicles (used only on later Apollo missions), and other equipment left on the surface by the crews. Conspiracy theorists examining these photos would immediately point to the lack of stars in the photographs as evidence of a hoax. Earth-bound observers are used to seeing a dark sky at night full of millions of stars. However, it is important to remember that these photos were not taken at night-time. The daytime sky on Earth is blue because of the oxygen and nitrogen atoms in our atmosphere. As the Sun's light passes through the atoms, a phenomenon called "Rayleigh Scattering" causes the light to scatter. While sunlight is made up of all the colors of the spectrum, the color blue is scattered more efficiently causing us to see the sky as blue. With virtually no atmosphere and no concentration of oxygen and nitrogen atoms, the light-scattering effect does not occur on the Moon. While the sky appears black in the

Apollo photographs, it is actually lunar daytime and the sunlight is very bright. The cameras used by the astronauts were preset for the conditions of lunar daytime photography. Exposure times were set to be short so that the main subjects of the photographs would be correctly exposed. A direct result of the short exposure time is that stars do not show up in the photographs. Earthbound photographers can easily test this for themselves by trying to take a photograph of the stars at night. The exposure time required to photograph the stars is so long that, if you were to use the same settings during the daytime the resulting photo would be horribly overexposed.¹²



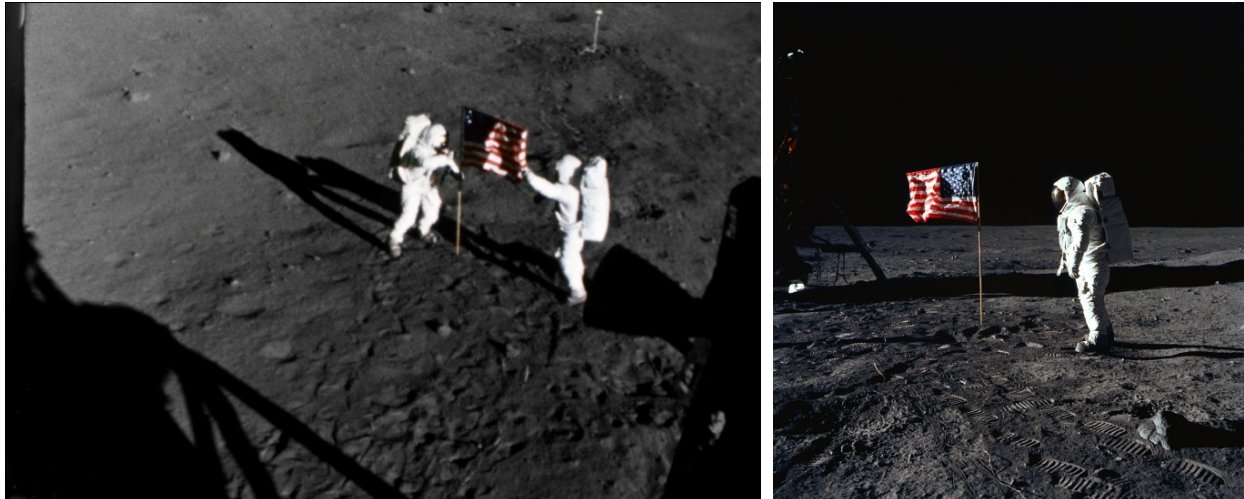
Figures 8–9: Apollo 15 astronaut James B. Irwin is shown with the American flag, the lunar module, and the lunar rover (left), NASA Photograph AS15-88-11866 (1 August 1971). Apollo 17 commander Eugene A. Cernan salutes the flag (right), NASA Photograph AS17-134-20380 (13 December 1972).

Another claim frequently used by conspiracy theorists is that the Apollo photographs show evidence of multiple light sources. The hoax theory proponents explain that this would only occur if artificial lighting was used, as would be the case in a photographic studio. Images from Apollo frequently show well-lit astronauts standing in shadows, or other features which the hoax theorists claim were highlighted for photographic effect. In the Apollo 15 photo that follows, the best illustration of this effect can be seen by examining the white label on the right side of the lunar module which shows the American flag and the words “United States”. This label was made of the same Beta cloth fabric as the spacesuits worn by the astronauts. Beta cloth was made of Teflon-coated glass fibers and is a tough fabric that is not only fireproof, but also highly reflective. The “spotlight” effect can also be seen in the Apollo 17 photograph, where you can see some equipment and insulating foil just underneath the lunar module. This material appears to be lit despite its position in the shadow of the lunar module. There are several good scientific explanations for why we see this effect in the Apollo photographs. One is the

reflective nature of the lunar surface. Walk outside on the night of a full moon and you will immediately see how much the sunlight reflected by the Moon can illuminate objects here on Earth, even from a distance of 356,400 km to 406,700 km (depending on the point of its orbit). Now, imagine what it might be like to stand on the surface of the Moon during the daytime. Sunlight reflects off the uneven lunar surface and is scattered in many directions. When that light hits another reflective surface, such as the white label on the lunar module, the white fabric of a spacesuit, a piece of reflective foil, or some polished metal, it is reflected yet again. This is also an explanation of why the flags in lunar photographs “glow”. The authors of the *Moon Base Clavius* site demonstrate that the “glowing flag” phenomenon also occurs on Earth. With a nylon flag it is difficult to determine if a flag is lit from the front, or from behind. The end result of the unusual lighting situation on the Moon is that it produced photographs with unusual lighting effects, but isn’t this what we should expect on the surface of an alien world?¹³

These unusual lighting effects and the varied topography of the lunar surface resulted in other effects that conspiracy theorists claim are evidence of multiple light sources—variations in the size and direction of different shadows in the photos. A good example of varying shadow lengths can be seen in a photo of the Apollo 11 astronauts as they raised the first United States flag on the Moon, taken by the 16mm Data Acquisition Camera (DAC) which was mounted in the Lunar Module. In the photo, mission commander Neil A. Armstrong stands at the flag’s staff (left), while lunar module pilot Edwin E. “Buzz” Aldrin is seen at the flag’s fly (right). Notice the difference in the shadows cast by the two astronauts. Conspiracy theorists Mary Bennett and David Percy suggest that this is because the astronauts are being lit by different light sources, resulting in shadows of varied lengths. However, they are standing very close to each other, so if there were multiple light sources it would be more likely that each astronaut would cast multiple shadows in different directions. If there was one artificial light source illuminating both astronauts (another suggestion of Bennett and Percy), the astronaut closest to the light source would actually cast the shorter shadow (in the photo it would be the astronaut at right, based on the direction of the shadows). One look at the photo clearly shows that the astronaut at right is casting the longest shadow. The more logical explanation for the different shadow lengths is that the terrain in the photo is not level. As the conspiracy theory debunkers of the *Moon Base Clavius* website explain, “The foreground of the image is darker than the background, indicating that the terrain is not at all level. The ground slopes downhill away from the camera to roughly the center of the image, then begins to slope upward again and receives more direct sunlight.” Another image of astronaut Buzz Aldrin with that same flag illustrates shadows which appear to be going in inconsistent directions. Compare the angles of the shadows cast by the lunar module (in the background), the astronaut, and the rock in the foreground at right. This variation in shadow directions is also evident in the Apollo 17 image show previously (see Figure 9). Conspiracy theorists suggest that shadows caused by the same light source should always be parallel to each other. This would be true if the surface of the Moon was completely flat. However, variations in the topography and optical illusions caused by camera perspective can easily produce shadows which are cast in different directions. The *Clavius* site includes a

number of lighting experiments that clearly demonstrate the different phenomena related to shadows and further validate the Apollo photographs. And, in their examination of the moon hoax conspiracy theory, the MythBusters successfully demonstrated how the reflectivity and topography of the lunar surface can produce inconsistent shadows with only one light source—the sun.¹⁴



Figures 10–11: Astronauts Neil A. Armstrong and Edwin E. “Buzz” Aldrin, Jr. raise the first flag on the Moon during the Apollo 11 Mission (frame from the data acquisition camera, left), NASA Photograph S69-40308 (20 July 1969). Still photo of “Buzz” Aldrin with the flag, taken by Armstrong a few minutes later (right), NASA Photograph AS11-40-5874 (20 July 1969).

Look at the two cropped photos that follow. In the one on the left, you can see an example of another phenomenon that leads the conspiracy theorists to believe that the moon landing photos were faked. This argument is based on the “crosshairs” which can be seen on the still photos from the Apollo missions. During the missions, the astronauts used specially modified Hasselblad cameras fitted with a device called a reseau plate. The plates were made of glass and had small black “fiducials” or “reticles” etched on them. Because the device is part of the camera, this resulted in these thin black crosshairs being superimposed at regular intervals on every photograph taken with the Hasselblad cameras. These markers were included because they can be used to establish a geometrical basis for measuring various objects in the photographs. Examine the close-ups below and you can see why the conspiracy theorists are interested in the crosshairs. In the top image, you can see that the crosshair at upper right appears to be behind the low-gain antenna of the lunar rover. According to the conspiracy theorists, this is an error introduced when objects were pasted into faked photos. Bennett and Percy suggest that the missing crosshairs could be deliberate errors introduced by whistle-blowers who were leaving clues in the manipulated photographs. In the case of the disappearing crosshairs, images of flags are perfect examples for demonstrating a much more logical explanation for this phenomenon. The image at right is a close-up of an astronaut with the flag from Apollo 15. For reference, the larger crosshair between the astronaut’s left knee and the flagpole indicates the center of the

original photograph. In viewing the photo, first look at the crosshairs to the left and right of the astronaut at about the level of his shoulder. Now, looking at the same horizontal line, find the next crosshair to the right that appears on the flag. You can see it on the fly of the flag starting on the third red stripe (counting from the top) and extending down to the lower edge of the fifth red stripe. What is important about the crosshair on the flag is that it is visible on the red stripes, but not on the white stripes. This validates the explanation that vanishing crosshairs occur when they are “washed out” on bright objects such as the white stripes. According to the *Moon Base Clavius* site, “The photographers we consulted agreed that the fiducial washout was almost certainly the result of bright areas of the emulsion “bleeding” over the tiny fiducials. The fiducials are very thin, only about 0.004 inch thick (0.1 mm). The emulsion would only have to bleed about half that much—less than the thickness of a human hair—in order to completely obscure the fiducial”.¹⁵

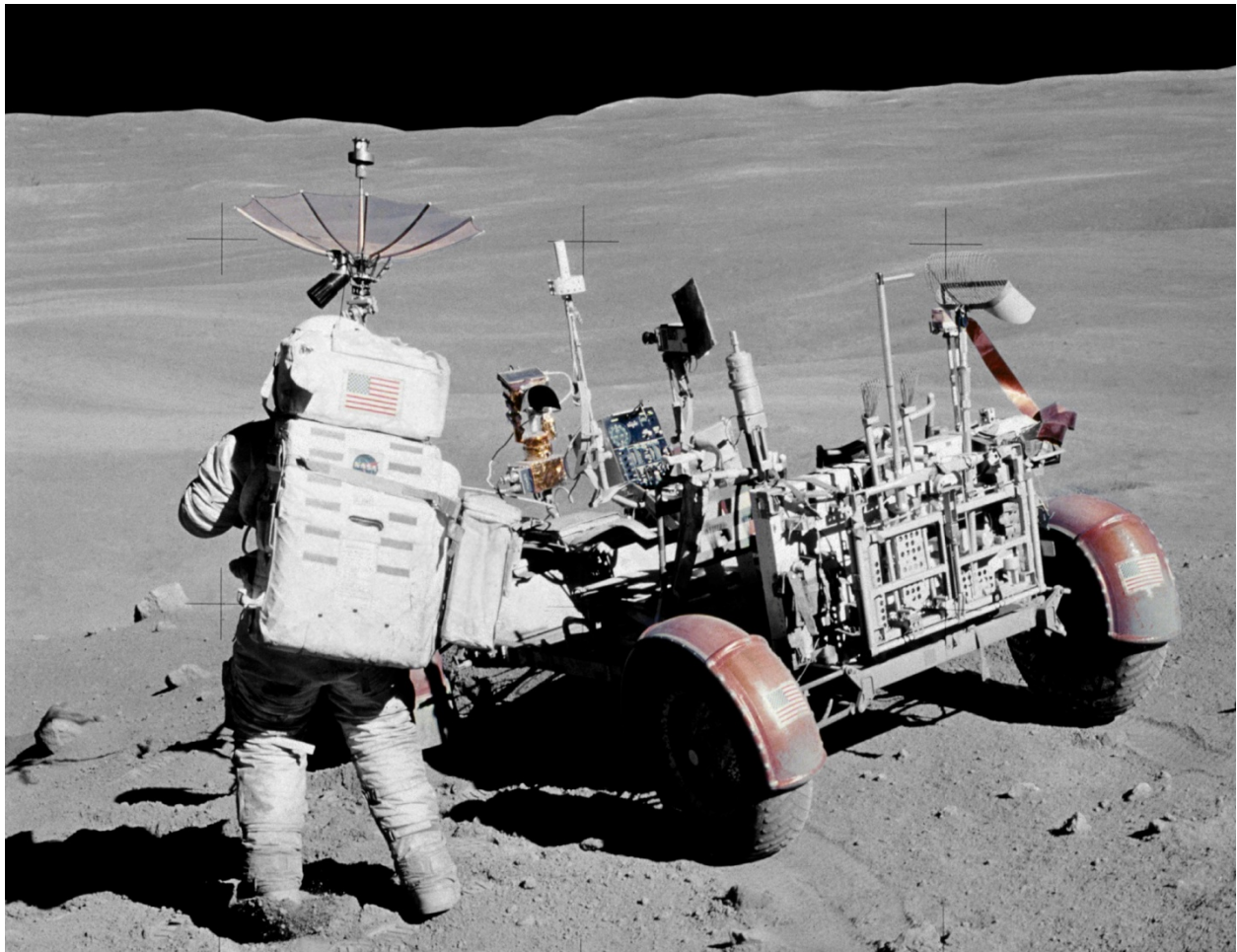
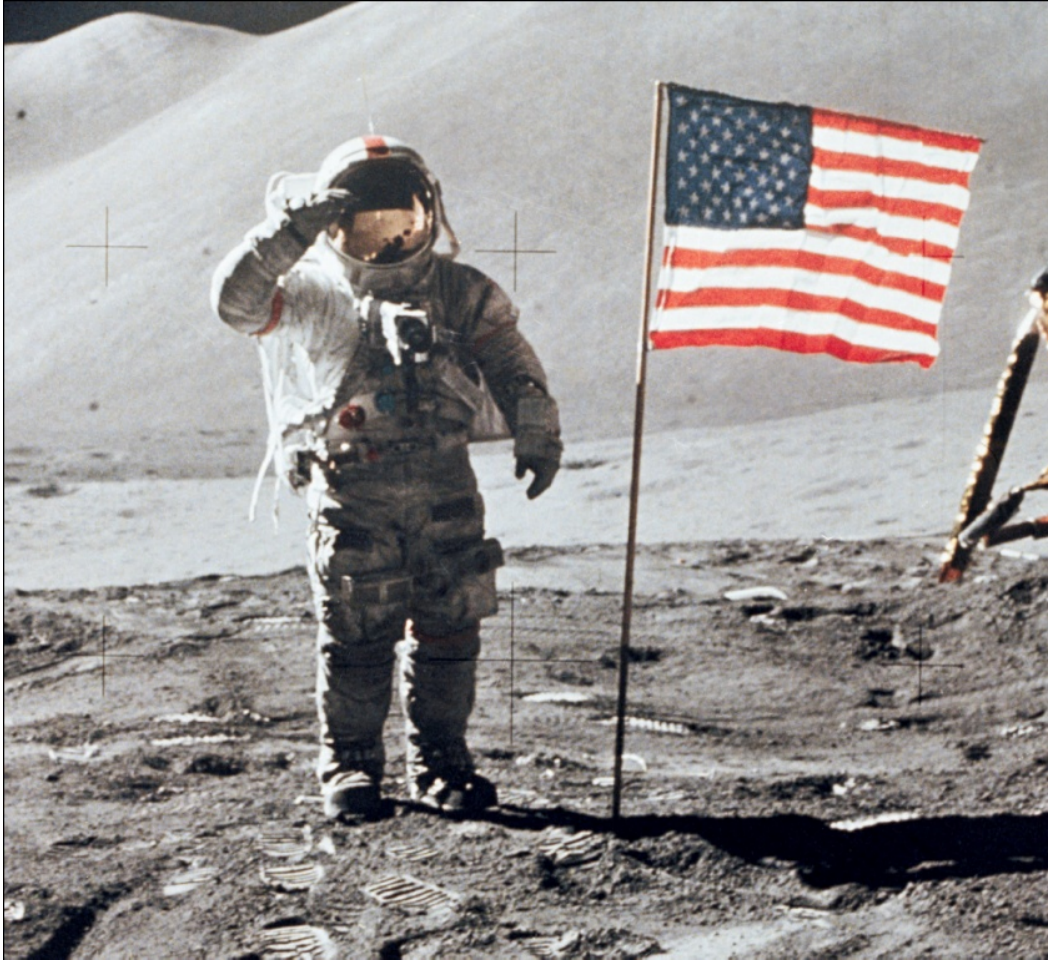


Figure 12: Cropped image showing Apollo 16 astronaut Charles M. Duke, Jr. and the lunar rover (left), NASA Photograph AS16-107-17446 (22 April 1972). Notice how the center crosshair “disappears” behind the low-gain antenna of the lunar rover.



Figures 13: Portion of a photograph of Apollo 15 commander David R. Scott and the American flag (right), NASA Photograph AS15-88-11863 (1 August 1971). In this image you can see that the crosshair is visible on the red stripes, but disappears behind the bright white stripes.

The arguments which have been discussed in this section are just some of those used by conspiracy theorists as “proof” that the moon landings were an elaborate hoax. It is striking to note, however, that no serious scientists have come forward with well-substantiated proof that astronauts never went to the Moon. Since the Apollo era, astronomers have been using special reflectors placed on the lunar surface by the astronauts to measure the exact distance to the Moon using lasers. During their episode about the moon landing hoax conspiracy theories, the MythBusters visited the Apache Point Observatory, where astronomers demonstrated how the laser experiment works. First, they pointed their laser at a bare spot on the Moon and showed how the laser beam is not reflected back. Next, they targeted the retroreflector that was left on the surface by the Apollo 15 crew. That laser beam was reflected back to the observatory, demonstrating that there really was a retroreflector on the Moon. In addition, geologists continue to study lunar samples returned by the Apollo astronauts—the most significant evidence of the reality of the Apollo missions. They have published their results in scholarly journals, expanding our knowledge of lunar geology. These scientists work independently of NASA and are not

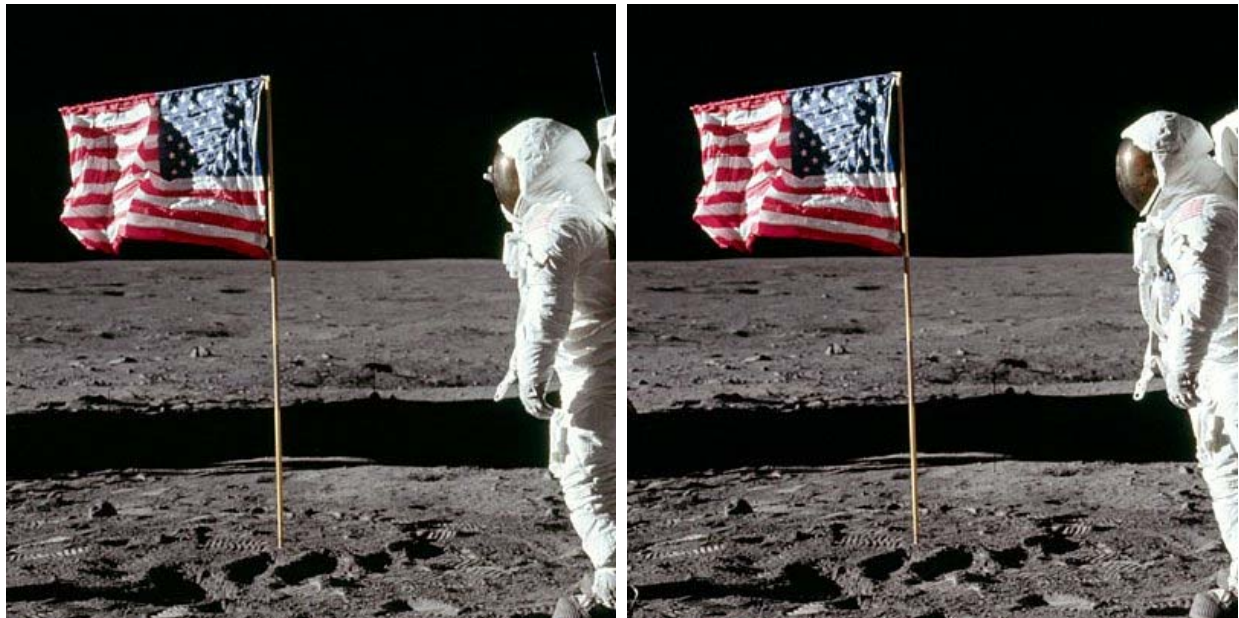
constrained by threats of official censure or the loss of their jobs. In addition, NASA has continuously given access to scientific information and samples from the Apollo program to scientists from countries around the world. Those scientists owe no allegiance to the United States and would have little motivation to help NASA cover up such a complex hoax as the conspiracy theorists claim has been perpetrated. Finally, there were hundreds of thousands of NASA employees and contractor employees who played a role in the missions of the Apollo Program. Not a single one of these individuals has come forward with the “smoking gun” evidence that would prove that the Apollo moon landings were faked.¹⁶

The Role of the Flags in the Moon Landing Hoax Theories

Now that we have covered the basic claims of the moon landing hoax conspiracy theorists, it is time to turn our attention to the specific claims they have made about the flags. Their evidence in this area is based entirely upon their examination of still photographs and videos released by NASA. The most frequently-made claim related to the flags is that in various instances you can see a flag being blown around by an errant gust of wind. Of course, since there is no wind on the Moon, this would be clear evidence that the moon landings were faked. The father of moon landing conspiracy theories, Bill Kaysing, did not mention this flag evidence in his book. However, in video interviews he does refer to the flag. As Kaysing explains in the Fox “Conspiracy Theory” show, “The fact that the flag flaps on the Moon where there’s no atmosphere means that there must have been a little blast of wind out in Area 51 when they shot this”.¹⁷

In still photos it is difficult to judge if a flag is really moving or not. However, when the same flag is viewed in different frames it becomes evident that the flags are not, in fact, moving. For example, two different frames showing Buzz Aldrin with the flag during the Apollo 11 EVA offer a good example of this. When looking at the still photos, it is at first difficult to see the differences between the two images. The differences are not in the position of the flag, but rather in the position of the astronaut. When looking at the flags, notice that the pattern of ripples in the striped portion of the flag’s field are repeated in both images. Also, you can see the same arc in the flag’s fabric near the staff that is reflecting the light. Now, turn your attention to the astronaut in the photograph. In the image at left you can see that the fingers of the astronaut’s right hand are visible just behind the visor of his helmet, but not in the image at right. This is because astronaut Aldrin was saluting the flag with his right hand when the first photo was taken. Also, compare the amount of the visor that is visible in both images, as well as the U.S. flag patch on his left shoulder. Finally, observe that you can see the antenna on the astronaut’s life support “backpack” in the image at left, but not in the version seen at right. An animated gif compiled from these two images can be viewed on *Wikipedia* at <http://en.wikipedia.org/wiki/File:AldrinFlag-animation.gif>. When viewing the animated gif, focus first on the flag and you will see no movement there other than the crosshair shifting slightly. Then, shift your point of focus to the astronaut and you will see his movement between

the two frames. Obviously, there is a better explanation for why the flag appears to be “flying” than the conclusion that the photo is a fake. It doesn’t take a very close examination of the flag to see that there is a horizontal crossbar holding the flag out from the staff. Conspiracy theorists also use still images from other Apollo flights as examples of “moving flags”. As with the Apollo 11 images below, the answer lies with the design of the flagpole. Details about the design of this special flagstaff, called the “lunar flag assembly”, will be covered in the next section of this paper.¹⁸



Figures 14–15: Buzz Aldrin salutes the flag on the Moon (left), NASA Photo AS11-40-5874. Buzz Aldrin as seen in the next frame of the mission photographs (right), NASA Photograph AS-11-40-5875 (20 July 1969). View an animated compilation of these images online at <http://en.wikipedia.org/wiki/File:AldrinFlag-animation.gif>.

Video evidence of the “waving flag” can be found in many of the cases presented by moon landing hoax conspiracy theorists. As with the still photography, all the video they use is freely available from NASA. Typically, they use video that was taken while the astronauts were either deploying or adjusting the lunar flag assembly. In these videos the structure of the flagpole is readily evident: the flag is attached to the vertical pole at the lower hoist, and a horizontal crossbar goes through a special sleeve at the top of the flag. Only one of the corners of the flag—the lower fly, flies free of the structure. For this reason, the flag flips around strangely as the astronauts manipulate the pole. Careful observation reveals that the free corner moves back and forth like the motion of a pendulum. While it is obvious to most observers that the movement of the flag in these videos is in response to the astronaut’s actions, many conspiracy theorists claim that it is actually caused by “wind” on the set used to film the fake moon landing footage. Perhaps they are inclined to believe this because the movement of the flag does not match what we would see if someone was moving a flag around on Earth. This is,

of course, due to the differences between the lunar environment and the environment here on Earth.¹⁹

A quick review of several concepts of basic physics and planetary science is helpful to reach an understanding of what we see in the Apollo flag videos. First is the difference in gravity. The Moon has a radius that is 27.3% that of Earth and a mass that is 1.2%. Therefore, the surface gravity on the Moon is about 16.5% or just under 1/6th what we experience on our planet. For this reason, an object that weighs 100 pounds on Earth would only weigh about 17 pounds on the Moon. There are also significant differences in the environments of the two worlds. As has been previously mentioned, on the surface of the Moon there is no “wind” or movement of air because the lunar atmosphere is so thin that it is virtually non-existent. The lack of air molecules results in a near-vacuum, and means there is no air resistance to cause drag on objects being moved around above the surface. The principle of inertia tells us that an object in motion will continue in motion unless it is affected by other forces, such as gravity or friction. What this means in terms of the flag’s motion is that once an astronaut releases the flag or flagpole, the cloth portion of the flag will move differently than it would on Earth because the pull of gravity is less, and there is no air resistance. The main force acting to bring the flag to rest is the “tether” point of the flagpole which is anchored to the lunar surface. These factors explain why the pendulum motion of the flag dies out so slowly.²⁰

Perhaps the easiest way to understand how flags move on the Moon is to view some of the footage provided by NASA. At this point, the reader is encouraged to pause and watch some video:

- Apollo 14 flag raising
 - .mpg file: http://www.hq.nasa.gov/office/pao/History/alsj/ktclips/ap14_flag.mpg
 - RealVideo file: <http://www.hq.nasa.gov/alsj/a14/a14v.1144108.rm>
- Apollo 16 “jump salute”
 - .mpg file: http://www.hq.nasa.gov/office/pao/History/alsj/ktclips/ap16_salute.mpg
 - RealVideo file: <http://www.hq.nasa.gov/alsj/a16/a16v.1202523.rm>
- Apollo 17 astronauts with flag
 - .mpg file: http://www.hq.nasa.gov/office/pao/History/alsj/ktclips/ap17_flag.mpg
 - QuickTime file: <http://www.hq.nasa.gov/alsj/a17/a17v.1182126.mov>

In watching the videos, pay careful attention to the movement of the flags in relation to the movement of the astronauts. In the Apollo 14 flag raising video, you can clearly see how the flag moves in reaction to the actions of the astronauts. The free corner of the fly flips around as the astronaut inserts the top portion of the pole into the base and then adjusts the flag. In the Apollo 16 footage, which shows John Young’s jumping salute (shown in figure 8) from the vantage point behind the astronaut, you see a flag that is already at rest. As the astronaut is moving, focus on just the flag. You will notice that it remains stationary and is not affected by any wind. Finally, the Apollo 17 video is an excellent demonstration of how flags continue to

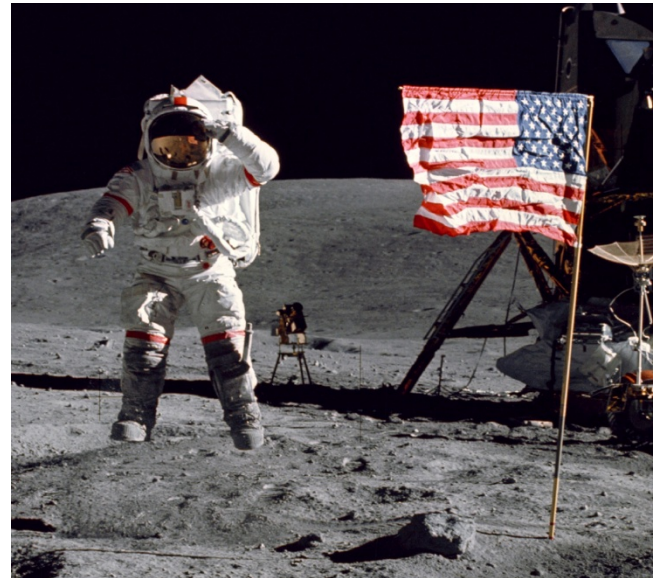
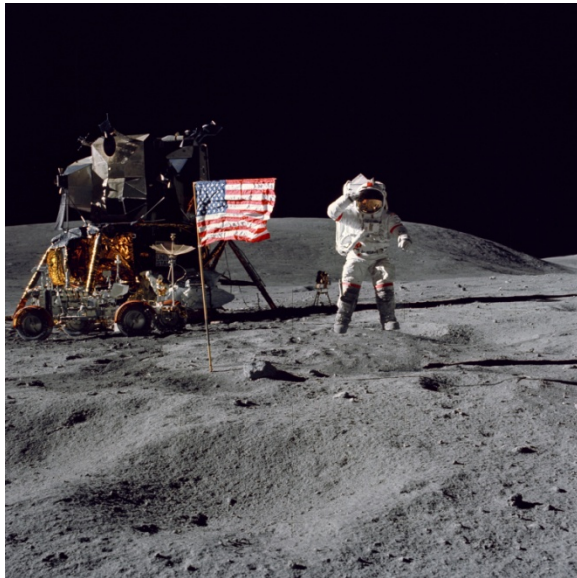
move after the astronauts release the flag. In this case, the corner of the flag moves back and forth until it succumbs to the force of the flagpole and the effect of lunar gravity. All of the motion is clearly due to inertia and not the result of wind. This explanation has been independently verified by the popular television series, *MythBusters*. Having requested a copy of the lunar flag assembly engineering drawings from me, they replicated the apparatus. Next, they took it to a vacuum chamber and demonstrated how the motion of the flag differs in an atmosphere and in a vacuum. Using a special astronaut analog, they moved the flag back and forth, and then released it. In a normal atmosphere, the momentum of the flag was quickly dampened due to air resistance. However, in the vacuum the flag continued to move exactly as it does in the Apollo moon landing videos.²¹

On hoax believer web sites and on the video site *YouTube* a portion of Apollo 15 footage has been the point of much discussion. In the sequence, astronaut David Scott runs by, passing between the flag and the video camera that is mounted on the lunar roving vehicle. From the perspective of the camera it is impossible to determine if he makes physical contact with the flag. However, his movement clearly influences the flag, as it goes from a state of complete rest to a condition where it moves back and forth slightly. The movement continues for a short time after Scott passes until the time that the flag loses the momentum that had been transferred from the astronaut. Hoax believers are convinced that the flag's motion is caused by the movement of air displaced by the astronaut's motion. Contributors to the *Apollo Lunar Surface Journal* website have suggested several more plausible explanations for the flag's movement:

- (1) Dave could have brushed against the flag with his left arm as he went by;
- (2) he could have kicked some dirt with his boot that hit the bottom of the flag;
- (3) he could have pushed a mound of soil sideways with his boot that pushed against the flagstaff ;
- (4) the impact of his boots on the ground as he ran past could have shaken the flagstaff;
- (5) he might have been carrying a static charge which attracted the flag material;
- (6) the flag could have been disturbed by emissions from the backpack.

In the analysis offered on the site, it is suggested that the most likely cause was that the astronaut had brushed against the flag. This conclusion is validated by an experiment posted on *YouTube* by an Apollo defender. Using data that is readily available in the Apollo 15 press kit such as the size of the flag and the height of the astronaut, he created a 3-dimensional computer model of the scene to replicate the relative positions of the astronaut and the flag. Use of a computer model allowed him to rotate the scene around so that it can be seen from different perspectives. In his analysis he demonstrates how the astronaut could have brushed against the flag with the sleeve of his spacesuit. Another important factor which supports the "brushing up against the flag" explanation is that we do not see a similar reaction in the flags in other mission videos when astronauts pass close to the flags.²²

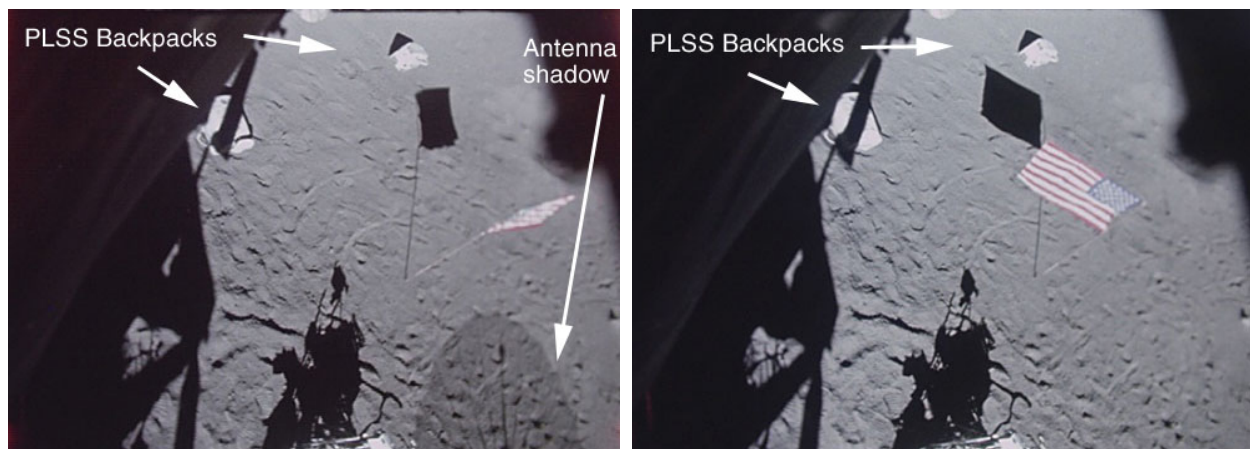
There is another claim about the flags in the conspiracy theories that is more challenging to address using the photographic evidence available. Hoax proponents sometimes suggest that in the still photographs and video footage from specific missions we are actually seeing different flags. This is an explanation offered by Mary Bennett and David S. Percy to explain perceived discrepancies in the images. For example, they use the still and video photography of John Young's famous "jump salute" from the Apollo 16 mission. They contend that the crossbar of flag in the still photo is at a 90% angle perpendicular to the pole, but in the video it is at a 70% angle relative to the pole. The difficulty with these claims is that they are comparing video images taken from one perspective with still photographs taken from a different perspective. To analyze this allegation, first study the flag in the image at lower left. This is the original still photograph of the event. Notice that the flag pole in this image is leaning to the viewer's left and is not exactly perpendicular to the ground, even though the crossbar looks straight. That means that the angle of the crossbar is actually less than 90% relative to the pole. Now, look at the reversed and enlarged portion of this same photo at lower right. By flipping the photograph horizontally it makes it easier to compare the still photograph with the extracted video frame shown above. There are several points of comparison that can be used to demonstrate that the flag in the still photo is the same flag as that shown in the video footage. First, look at the lower fly of the flag where the second red stripe up from the bottom appears to be touching the next red stripe up. This same fold can be seen in the video frame. Now, look at the fold at the border of the second white stripe and the third red stripe from the top. Because of this fold, the canton appears to jut out into the stripes in this part of the flag. When you look at the video image you can see evidence of this same fold. An additional point of comparison can be found on the third white stripe up from the bottom. Look at the point in the still photograph that is about 1/3 the length of the flag from the fly, where the two surrounding red stripes appear to almost be touching. This spot can also be seen on the same white stripe on the flag in the video frame. It appears to be slightly closer to the fly in the video because of the difference in perspective. Another way to understand the optical illusion caused by the difference in perspective between the still photo and the video is to think about an Earth-bound analog. When you are riding in the front passenger seat of an automobile with a non-digital "needle" speedometer gauge, observe what speed you think the car is going. Then, ask the driver how the speedometer reads from his perspective. The speed will look lower to the passenger in a car with a left-hand steering wheel (and higher in a car with a right-hand steering wheel) because the speedometer is designed for the perspective of the driver. This difference in the apparent position of an object when viewed from two different lines of sight is called "parallax".²³



Figures 16–18: Extract from an Apollo 16 video showing astronaut John Young’s famous jump salute from behind (top). Compare this view to the still photo of the event taken from the other side of the flag (bottom left) and an extract of that same image flipped horizontally and enlarged (bottom right). NASA Photograph AS16-113-18339 (21 April 1972).

Perhaps one of the best examples of how moon landing hoax conspiracy theorists selectively use evidence out of context is the case of two still frames from an Apollo 14 video which show the flag. In one image the fly of the flag points out to the right, but in a later frame

it is pointed to the left. There are no astronauts in the transitional frames to have altered the direction of the flag. This sounds like clear-cut evidence of “wind” until the timing on the video is compared with the mission logs. The two frames with different flag directions were discovered by Robert Godwin, the author of multiple books on space exploration. In an interview published in the *Winnipeg Free Press*, Godwin explained that he was extracting images from the video to fill in a composite panoramic view of the Apollo 14 landing site for a new book. When he found the two frames with the flag facing different directions he wondered what had happened. However, there were several important clues in the images which helped him determine why the flags had moved. First, he noticed that both of the astronauts’ Portable Life Support System (PLSS) backpacks are visible on the surface of the Moon. This vital piece of equipment was discarded only after the crew had completed their final activities on the surface. So, this confirmed that the crew did not play a role in the movement of the flag. Second, Godwin also noticed that the shadow from the large dish-shaped S-Band antenna had disappeared during the time between the two frames. This indicated to him that a significant force had acted on both the flag and the antenna. A little research led him to a rational explanation—the mission transcripts clearly indicated that during the interval between the two frames the astronauts had test-fired the thrusters on the lunar module. It was the force from the engine and not wind that had turned the flag around. In looking at video footage from the Apollo 12 mission, he discovered the “flag flip” was evident in that video, as well.²⁴



Figures 19–20: Two “smoking gun” images extracted from Apollo 14 video footage by Robert Godwin. Notice that in the photo at left the fly of the flag goes to the right, and in the one at right the fly is going to the left. There are no astronauts in the transitional frames who could have moved the flag, so what has happened? Conspiracy theorists claim that flag movement in moon landing videos was caused by the wind, but there is a more rational explanation—the flag was flipped by the force of testing the engines on the lunar module. (Photos extracted and labeled by Robert Godwin).

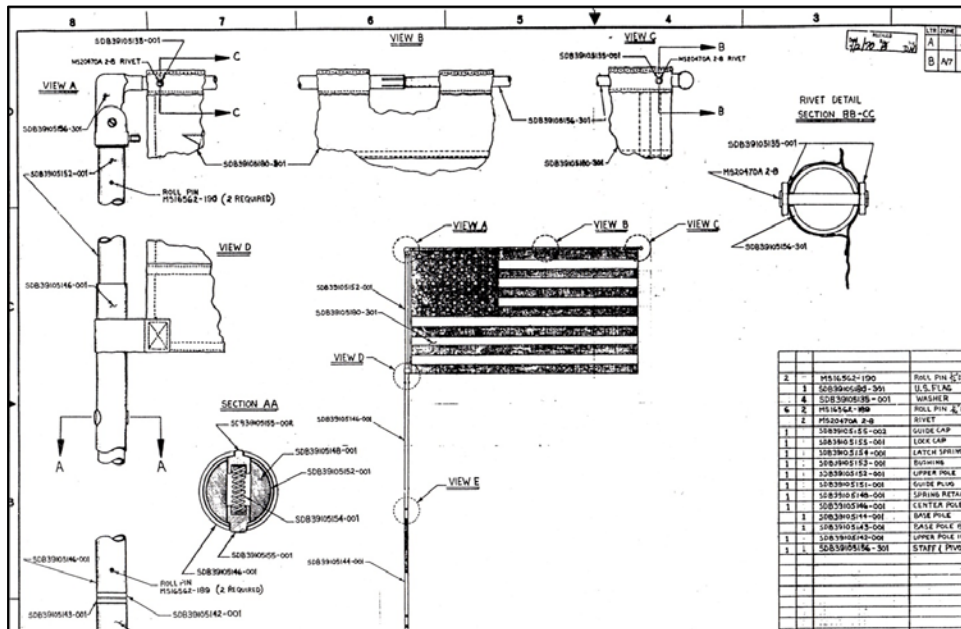
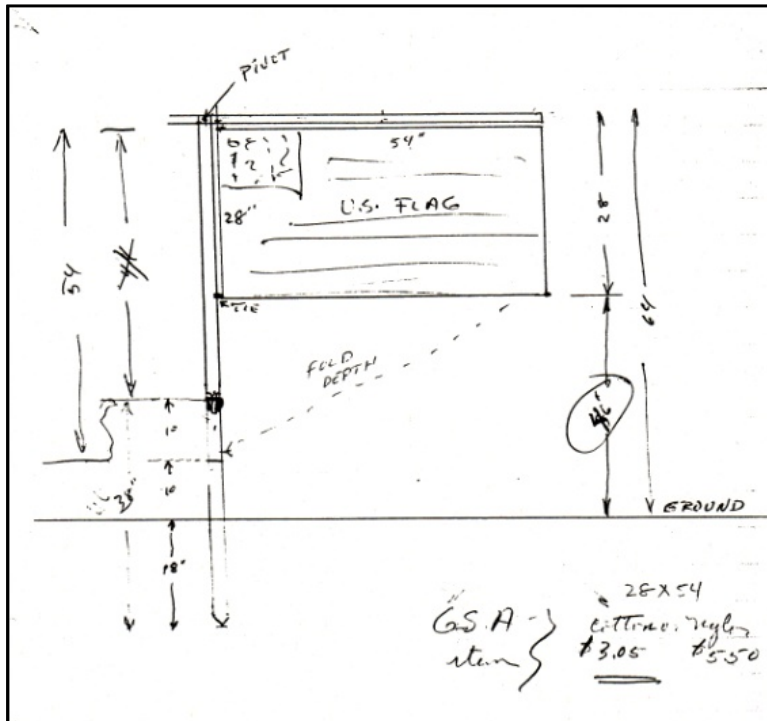
Ironically, what started as a story about how two images could be easily misconstrued quickly evolved into a story on the Fox News website reporting that Godwin had found evidence to lend credence to conspiracy theories about a faked moon landing. They chose to reprint only

the first paragraph of the story—the part in which Godwin discusses the discrepancy he had found in the footage. The lead sentence of the Fox article read: “A Canadian book publisher says images acquired by the Apollo 14 astronauts just before they left the Moon 40 years ago will fuel the speculation that the lunar landings between July 1969 and December 1972 were hoaxes”. The news site did not, however, include the portion of the story which explained that the engine tests had caused the movement of the flag, ending their story with the quote “My first reaction was: ‘What’s going on here? How is it possible that the flag can turn around 120 degrees?’”. Fox News has since replaced the story with a retraction explaining that their original story “was incomplete and incorrectly portrayed Robert Godwin’s position regarding questions surrounding photos from the Apollo 12 and 14 missions.” Still, the case of Fox News’ report on the Apollo 14 flipped flag images is an excellent demonstration of how easy it is to take two frames of video and misinterpret what has really happened. In the world of the moon landing conspiracy theories this is frequently the case. News of Godwin’s “find” can be found repeated on conspiracy blogs, and some even include his interpretation of what happened included in the text. Yet, the conspiracy theorists prefer to cling to an unlikely scenario that supports their theory, rather than investigate the situation and find the rational, scientifically-valid explanation.²⁵

Design and Construction of the Lunar Flag Assembly

The reason flags appear to be “flying” and “fluttering” in moon landing images is quite simple—the flagpole was designed specifically to give this impression. When NASA decided to place a flag on the Moon, they set about designing a special flagpole which was called the “Lunar Flag Assembly”. The initial sketch for the assembly shows a staff with a horizontal crossbar to hold the fly of the flag out away from the pole, so that it would not hang limply on the pole. As with any piece of equipment designed for the Apollo Program, the sketch was converted to a set of NASA engineering drawings which were then used as the specifications for the manufacture of the training and flight hardware. There were several important constraints that influenced the final design. First, it was necessary to design a flagpole that could be easily handled and deployed by astronauts wearing spacesuits pressurized to approximately 3.7 pounds per square inch (0.2601 kgf/cm²). The spacesuits also restricted the astronauts’ range of motion and the amount of force that they could apply to an object. In addition, the flagpole and associated hardware had to be as lightweight as possible. It was vital to keep the weight of unessential equipment as low as possible, and to reduce the overall weight that needed to be launched from Earth. Jack Kinzler’s notes about the parts of the flag assembly for Apollo11 record the following weights: the nylon flag (9.75 oz. / 276 g), the inner thermal package (13 oz. / 369 g), and the metal hardware and outer shroud (8 lb. 0.25 oz. / 3.64 kg). Kinzler’s notes indicate that the weight of the flag, metal poles, and the wrapper combined was 2 3/4 lbs. (1.25 kg). The press release for the mission indicates that the weight for the flag and staff without the packaging and mounting hardware was 3 pounds (1.36 kg). Both Kinzler’s notes and the press

release agree that the total weight of all of the components for the first lunar flag assembly was 9 pounds and 7 ounces (about 4.28 kg).²⁶



Figures 21–22: Original sketch for the lunar flagpole (above). NASA’s engineering drawing for the lunar flag assembly (below). See appendix for larger version of the engineering drawing. See footnote 26 for a rejected design for the lunar flagpole.

In the engineering drawing you can see the complexity of the design for the lunar flag assembly. NASA technicians at the Manned Spacecraft Center (renamed the Johnson Space Center in 1973) built the device using a commercially-available nylon U.S. flag. The flag was then altered to prepare it for use with the special lunar flagpole. According to a NASA press release about the flag, the binding and labels at the hoist were removed in preparation for attaching the flag to the vertical pole. They also sewed a hem along the top edge of the flag to make a sleeve for the horizontal crossbar. In addition to the top sleeve there were two rivets, one on each end of the crossbar, which attached the nylon flag to the flag assembly hardware. The flagstaff was made from aluminum tubing which was about an inch (2.54 cm) in diameter, with a wall approximately 1/32 of an inch (0.079 cm) thick. It was anodized, meaning that a coating was applied to it electrolytically, strengthening the pole and giving it a gold color. The pole consisted of two pieces—a base section and the upper pole, each 4 feet (121.9 cm) in length. To deploy the flagpole, the astronauts first used their geologic sample hammer to position the base in the ground. A red line painted on the pole, 18 inches (45.7 cm) up from the bottom, indicated the farthest point the hardened steel point and lower pole should be driven into the surface. In reality, though, the base was usually planted about 6-8 inches (15.2-20.3 cm) into the ground. Once the base was in place, the top part of the pole could be nested into the bottom part, with an overlap of 4 inches (10.2 cm). According to the Apollo 11 press release, when the flagpole was fully assembled it was 7 feet, 8 inches (233.7 cm) tall. Later NASA press releases (those for Apollo 13 through Apollo 16) indicated that the flagstaff was 8 feet tall. It is unclear whether this figure was derived by adding the length of the two 4-foot sections of the pole, without taking into consideration the 4 inch overlap where the upper pole nests into the lower pole, or if the pole design was altered slightly so that the entire assembled height of the flagstaff was a full 8 feet (243.84 cm).²⁷



Figure 23: This photo shows the different parts of Apollo 11’s lunar flag assembly, the insulating blanket, and the protective shroud. Below is the flag apparatus made of a standard nylon flag and a 2-part pole. The pole lying on top of the flag is the base. Just above it you can see where the flag is bunched up around the telescoping horizontal bar (which sticks out a bit to the left of the top red stripe). This crossbar is hinged to the top portion of the pole (look to the right of the blue cloth at the top of the canton). Above the flag are the Velcro closure strip and the insulating blanket that is packed around the flag. Just above that is the stainless steel outer case of the insulating shroud. The brackets to the left and right of the flag are used to mount the entire package on the ladder of the lunar module. To remove it and open the package, the astronauts pulled out the “pip” pin—which is connected to the red tab seen at the far left of the shroud. (NASA JSC Photo S69-38748).

The upper portion of the pole was the most complicated part of the apparatus. It included the remainder of the vertical pole and a telescoping horizontal crossbar, attached to it with a hinge. To unfurl the flag, the crossbar was extended and lifted up to a position just above 90°. A catch on the hinge would then lock in place, preventing the bar from lowering again. During the Apollo 11 mission, they had difficulty extending the crossbar to its full length. This gave the flag a “ripple” effect and some later crews copied this by not extending the bar all the way. The Apollo 12 astronauts had difficulty getting the catch to work on their flag, so that the crossbar was not at a right angle to the pole. After that mission the catch was redesigned to use a double-acting catch, so that later crews could get the crossbar into position without lifting it up as high.²⁸



Figures 24–25: A NASA engineer (on Earth) indicates the location where the lunar flag assembly was mounted on the ladder of the lunar module for Apollo 11 and 12. After removing the protective shroud (left), he removes the Velcro strips in order to open the insulation package (right). (NASA JSC Photos S69-38755, S69-38756).



Figures 26–27: In the next steps of the deployment he removes the insulation from around the flag assembly (left) and then takes the flag from the mounting brackets (right). (NASA JSC Photos S69-38757, S69-38758).



Figures 28–29: Next, the engineer shows the two parts of the lunar flag assembly—the lower pole, and the upper pole with the flag folded around it (left). He then extends the telescoping crossbar (right). (NASA JSC Photos S69-38759, S69-38760).



Figures 30–31: After extending the horizontal bar, he lifts the top of the flag up until the latch catches and it stays up on its own (left). He then slides the lower portion of the hoist down to its proper position (right). (NASA JSC Photos S69-38761, S69-38762).



Figure 32: With the top portion of the flag unpacked and deployed, the engineer then moves it into position to be nested within the top of the base portion of the pole (bottom). (NASA JSC Photo S69-38763).

In addition to the crossbar latch redesign there were other changes made to the lunar flag assemblies for the missions after Apollo 12. The first two flag assemblies were mounted on the ladder of the lunar module. They were exposed to the heat of the LM engines and experienced temperatures of 2,000°F (over 1093°C) during the last 13 seconds of the spacecraft's touchdown phase. For this reason, the flag and insulation package were fitted into a protective metal shroud, which was then mounted to the ladder. Throughout the Apollo program the engineers were always looking for a way to reduce the weight of the equipment launched from Earth. Following the Apollo 12 mission, the flag assembly was moved from the mounting on the LM ladder into the modularized equipment stowage assembly (MESA)—a special compartment on the outside of the lunar module's descent stage where they stowed the cameras, geologic hammers and scoops, and other equipment the crew needed during their extravehicular activities. This shift in stowage location meant that they could eliminate the metal thermal shroud and mounting hardware from the flag assembly, significantly reducing the overall weight of the equipment.²⁹

Another change which was made after Apollo 12 was in the size of the flags used. The first two flag assemblies incorporated flags that were 3 x 5 feet (91.44 x 152.4 cm). According to the NASA press releases for Apollo 13 through Apollo 16, the flags for those missions were slightly smaller in size, using a 2.5 x 4 foot flag (76.2 x 121.92 cm). No reason was given for the change in the size of the flag, but it was most likely made to reduce the overall weight of the flag assembly. Most Apollo press releases state that the size of the pole was 8 feet (243.84 cm), probably just based on the combined length of the two 4-foot (121.92 cm) sections. However, some of the press releases note that when the top part of the pole was nested into the bottom portion, the assembled pole was 7 feet, 8 inches (233.7 cm) tall, due to the overlap from the

upper pole fitting into the base. In order to verify the size change for the flags, I conducted an experiment using photographs from the six moon landing missions. To avoid making mistakes because of the different perspectives in the photographs, which can make the length from pole to fly difficult to judge, I only measured the width of the flag at the hoist. In addition, so that I would not introduce a bias based upon the information in the press releases, I used a neutral unit of measurement which I called a “flag width”. In the photos I measured the dimensions of the flag against the pole in order to define one flag width. Next, I drew lines farther down the pole to show where the next two flag widths would occur. Since I know the poles were the same length on all the missions I was able to deduce which size flag was used, based upon how far the third line was below the lowest visible point of the pole. Using this method, I confirmed that the flags for Apollo 11 and 12 were 3 x 5 feet and that those used for Apollo 14 through Apollo 16 were 2.5 x 4 feet.³⁰

When I tried to apply this methodology to examining the Apollo 17 flag, however, I had difficulty making a determination. There is no information in the press release that indicates either the size of the flag or the size of the pole. Assuming that the pole size was consistent for all Apollo missions, it is clear that the flag is not larger than a 3 x 5 foot flag, as there is too much pole showing above the lunar surface. I was able to eliminate that it is a 2.5 x 4 foot flag because it is very unlikely that the crew would have driven the base part of the pole over two feet into the ground. However, if it is a 3 x 5 foot flag it would mean that the crew had driven the pole about 16 inches (40.6 cm) into the surface. Looking at all the other Apollo flags it looks like all the other base poles go about 6-8 inches (15.2-20.3 cm) into the surface. This led me to conclude that it might have been a size other than one of the regular commercially-available U.S. flag sizes. There are several factors that support this hypothesis. First, the Apollo 17 flag was significant in that it was the flag that had been on display in the Mission Operations Control Room (MOCR) during other Apollo missions. When the crew planted the flag astronaut Harrison Schmitt mentioned the reason for doing this:

Houston, I don't know how many of you are aware of this, but this flag has flown in the MOCR since Apollo 11. And we very proudly deploy it on the Moon, to stay for as long as it can, in honor of all those people who have worked so hard to put us here and to put every other crew here and to make the country, United States, and mankind, something different than it was.

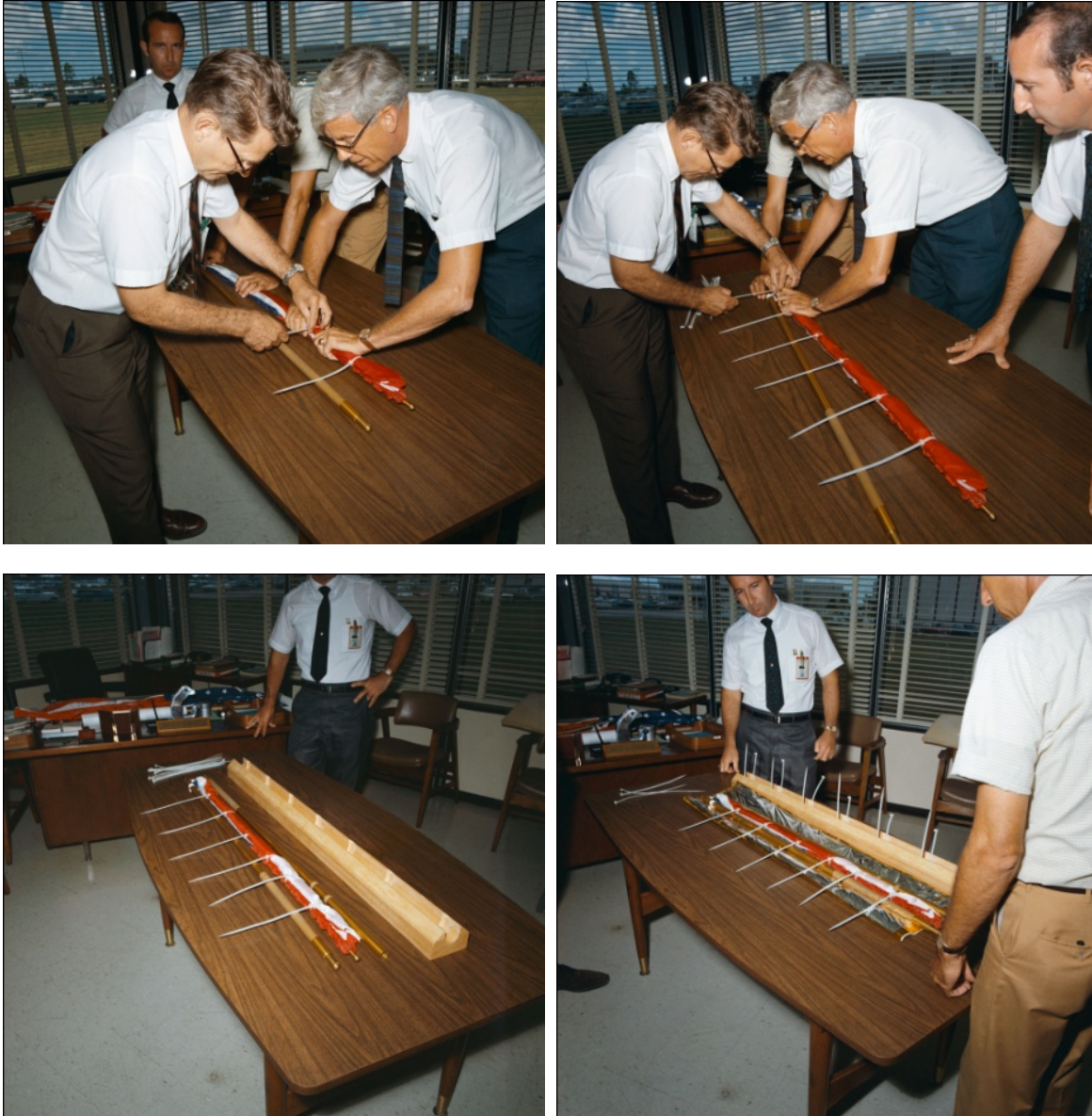
So, we know that this flag was used in an indoor flag display before it was converted to be used in the lunar flag assembly. Many of the flags on display in NASA offices are obtained from the Government Supply Catalog. This catalog includes American flags made in sizes that conform to U.S. government specifications (often called G-spec flags). One of these sizes is 3.5 x 6.65 feet (106.68 x 202.692 cm). When the Apollo 17 flag is examined using 3.5 feet as one “flag width”, it means that the base pole is embedded about 6 inches into the ground—a distance consistent with all the other Apollo flags. This therefore leads me to conclude that the flag was most likely a flag of that size. While this discussion of different flag sizes may initially seem

like a distracting tangent from the discussion of the role of flags in moon landing conspiracy theories, I actually believe that it provides additional evidence of the historical validity of the Apollo missions. If the missions had been faked, as the hoax theorists believe, why would NASA have bothered with all these variations in flag sizes? Wouldn't it have been simpler to just use the same prop flag on all the missions and just vary the appearance of the wrinkles? Why would they have reduced the size for three missions and then increased it to an unusual size for the final mission?³¹

There is one other factor that contributes to the illusion that the flags are “flying” in a lunar breeze—the wrinkling of the flag fabric. The flags were packed very tightly following a written 12-step procedure performed by 4–5 people. They used temporary spacers and plastic ties to hold the flag in place until it was placed in a thermal insulating package. The ties were then removed and the package was sealed with a Velcro “rip” strip. For Apollo 11 and 12, the insulating package was installed into the metal protective shroud and was ready to be attached to the ladder. When the flag was removed from all this packaging it was heavily wrinkled. On Earth it would take the use of an iron to smooth the flag out, but there was nothing on the Moon to remove the wrinkles. If you examine the images of the lunar flags you can see extensive evidence of wrinkling. The wrinkles and the partially-extended crossbar on the flags all contribute to the effect of a “fluttering” flag.³²



Figures 33–34: Series of photos showing a group of NASA engineers packing the lunar flag assembly in preparation for the Apollo 11 flight. The flag is packed very tightly following a 12-step written procedure. (NASA JSC Photos S69-38765, S69-38766).



Figures 35–38: Plastic ties are used to temporarily hold the flag in place. The engineers then begin to wrap it in the insulating blanket using a wooden form. After this the ties are removed and the insulating package is closed with a special Velcro strip, preparing it for insertion into the protective shroud. (NASA JSC Photos S69-38767, S69-38768, S69-38769, S69-38770).

Are the Flags Still There?

Even with all the photographic evidence and scientific explanations that have been presented to counter the claims of the conspiracy theorists, those who believe that the moon landings were faked require even more proof that the Apollo moon landings actually occurred. People often ask if it would be possible to view the landing sites using Earth-bound telescopes, and thus prove that the missions were real. Unfortunately, there are no telescopes on the planet

that can view the Moon in the level of detail that would be required to see any of the man-made objects left on the surface by the Apollo astronauts. The best way to photograph the landing sites is either from lunar orbit or by revisiting those locations with either a robotic or manned mission.³³

Since the last astronaut walked on the lunar surface in 1972, 17 robotic missions have been launched to the Moon by various countries. These spacecraft have been tasked with returning lunar samples to Earth, studying the Moon from orbit, and analyzing the properties of the lunar surface in situ (in place). Each generation of spacecraft has featured improvements in imaging technology, with dramatic increases in the resolution of the images. One of these, the Lunar Reconnaissance Orbiter (LRO), was launched by NASA on 18 June 2009. The orbiter was designed to map the lunar surface from a polar orbit and is currently circling the Moon at a distance of 50 km (31.07 mi.) from its surface. As the spacecraft orbits the Moon it returns very detailed photographs of the surface. These photographs have included images of all six Apollo landing sites. Close inspection of the images reveal photographic evidence of hardware left on the Moon during the Apollo missions and even show tracks left as the astronauts moved across the dusty surface. One image of the Apollo 17 landing site even shows the American flag left on the Moon during that mission.³⁴

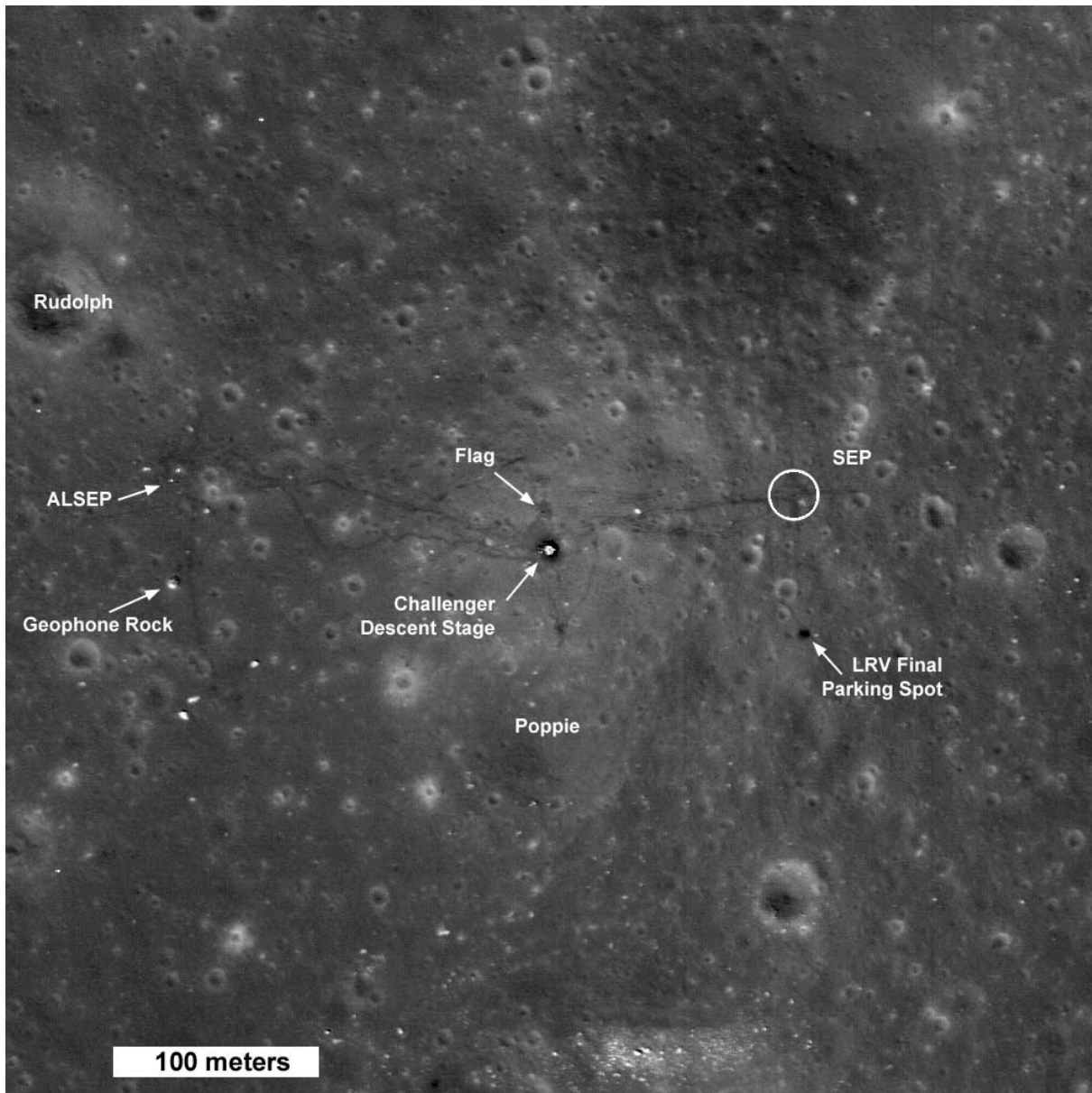


Figure 39: An orbital image of the Apollo 17 landing site shows tracks left by the astronauts, as well as artifacts of the mission. Labeled in this image are several features of the Taurus-Littrow region—Rudolph and Poppie craters, and Geophone rock. Two experiment packages, the Apollo Lunar Surface Experiments Package (ALSEP) and the Surface Electrical Properties (SEP) experiment, are also labeled. The descent stage of the “Challenger” lunar module, the lunar roving vehicle (LRV), and the flag are visible in the photo.

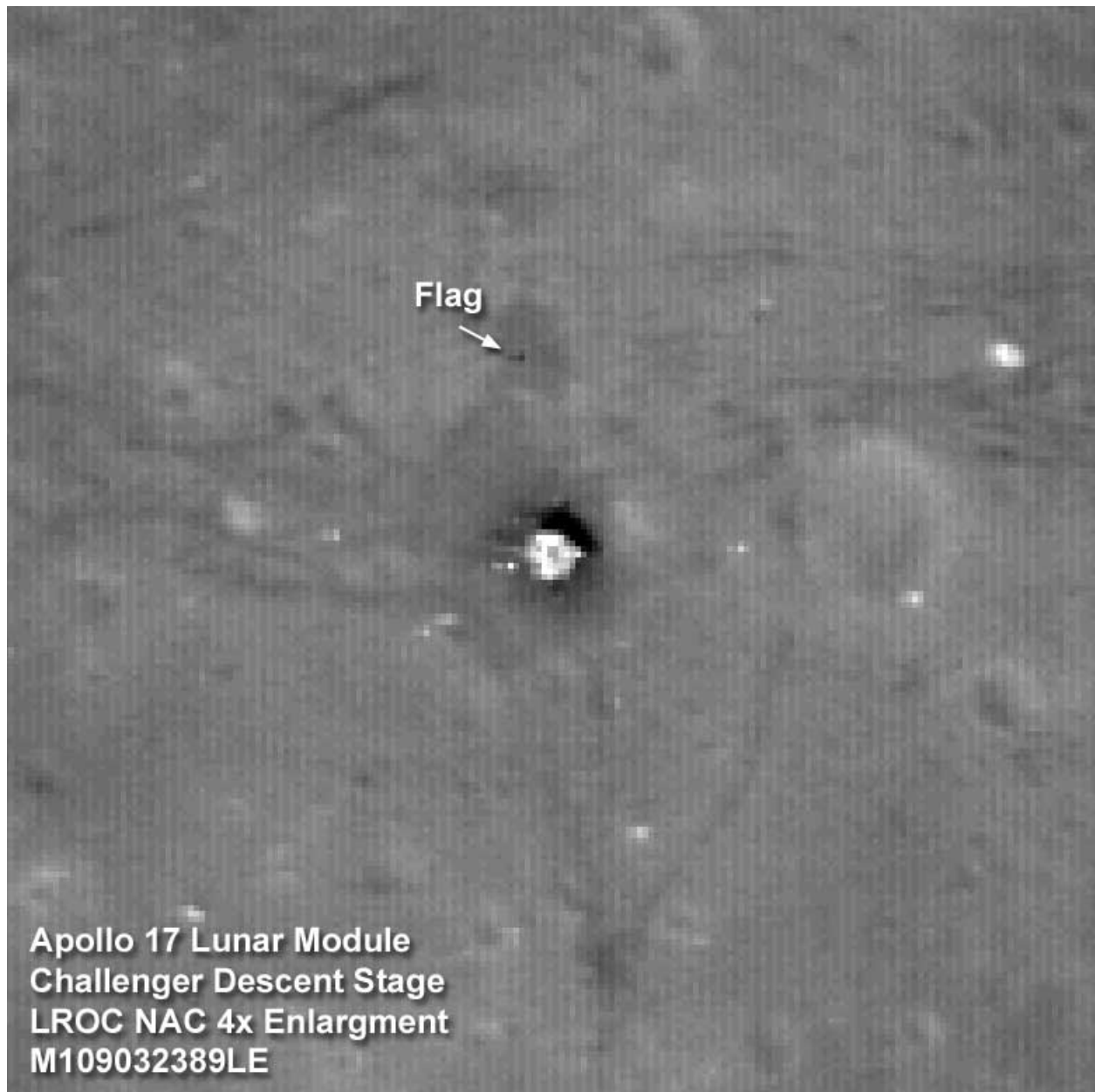


Figure 40: Enlargement of the photograph of the Apollo 17 landing site showing more detail of the lunar module (center of the image) and the flag (marked and labeled by the LROC analysts).

In the close-up LRO image of the Apollo 17 site, a faint black line shows the crossbar of the lunar flag assembly. But what remains of the actual fabric flag? This is one detail that orbital photography can't provide. However, there are assumptions that can be made based on our knowledge of the lunar surface and what we know about the properties of nylon. It is well known that the lunar surface is a very hostile environment, not just for humans but also for man-made materials. There are a number of environmental factors that most certainly have altered the condition of the flags since they were first deployed on the lunar surface over four decades ago.

The first question that people usually ask about the condition of the flags is whether or not they are still standing. It is difficult to know which flags might have fallen over and which remained standing when the crews departed. In his memoir Buzz Aldrin described what it was like when they put up the flag. “Just beneath the powdery surface, the subsoil was very dense. We succeeded in pushing the flagpole in only a couple of inches. It didn’t look very sturdy.” A famous bit of Apollo 14 video footage shows a flag shaking violently on its staff as the astronauts blast off in the ascent stage of the lunar module. However, as the flag moves out of the frame it is still standing. In addition, there is footage from cameras mounted on the lunar rovers to confirm that the Apollo 16 and Apollo 17 flags stayed up after the LM’s ascent. There is no footage of the Apollo 11, Apollo 12, or Apollo 15 ascents showing the flags. Since we know that the Apollo 15 flag was placed much farther away from the LM it is most likely that the flag from that mission was not toppled by the blast from the LM’s ascent engine. Therefore, only the status of the flags from Apollo 11 and Apollo 12 are really in question. From the evidence that is currently available to us it is impossible to determine if they fell over or remained standing.³⁵

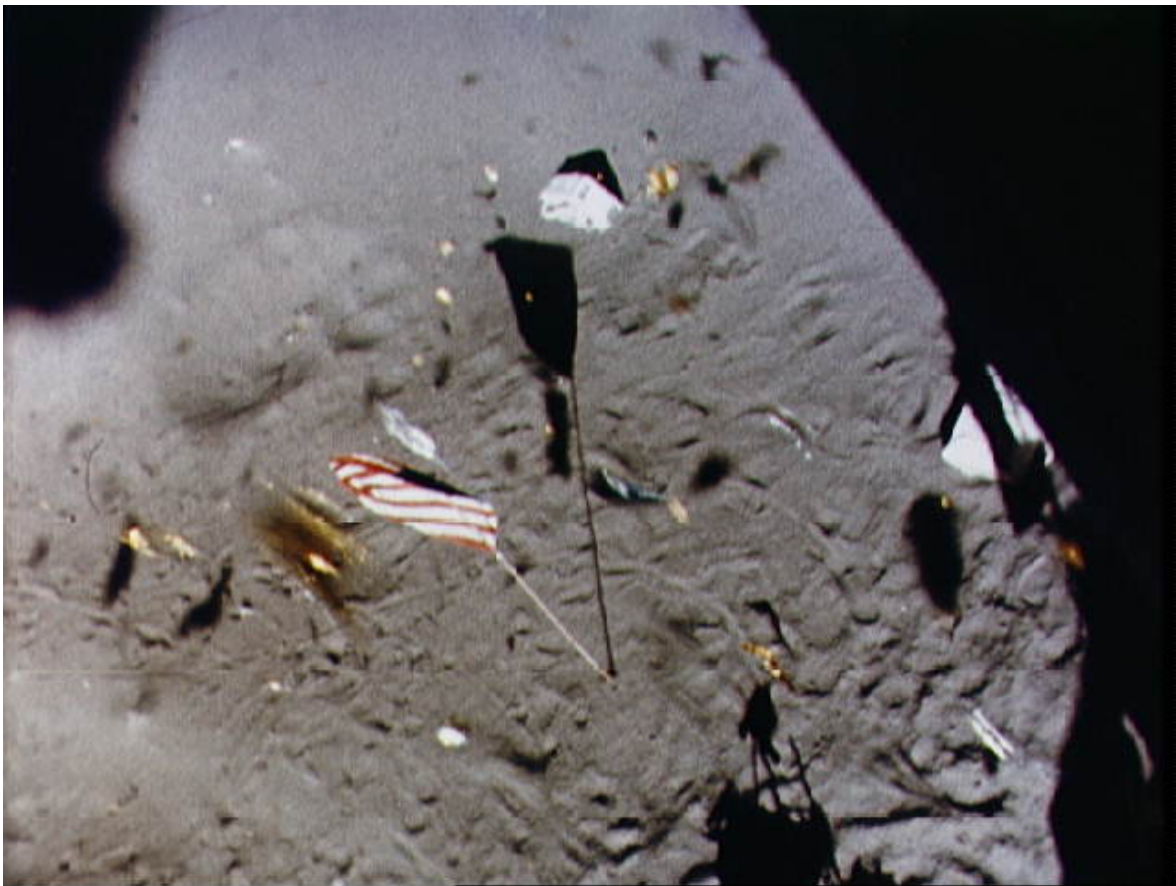


Figure 41: This frame extracted from an Apollo 14 video shows the flag through the window of the lunar module as the ascent stage lifted off from the surface. While the video shows the flag twisting around in the engine blast, it does not show the flag blow over. As the flag moves out of the shot, it is still standing. NASA Photo S71-19500 (5 February 1971).

Even if the flags have remained standing, it is almost certain that they are not in the same condition as when they were left on the Moon. Most likely the nylon of the flag has degraded as the result of prolonged exposure to sunlight, similar to what we would expect to happen on Earth. The technical name for this process is “photodegradation”, but it is commonly called “sun rot”. It results in the breakdown of nylon fibers and reduction of the structural integrity of the flag. Experimental research has shown that photodegradation of nylon occurs in both oxygenized and non-oxygenized atmospheres. In nitrogen test environments scientists found that photodegradation caused nylon fibers to lose their tensile strength and became brittle. While I did not find any studies which looked at the process in a simulated lunar atmosphere, where the primary elements are neon, hydrogen, helium and argon, it is safe to conclude that over 40 years of exposure to unfiltered sunlight would have had a similar effect on the lunar flags. The fabric of the flags will have become brittle and may have disintegrated.³⁶

Another way in which the flags have most certainly been affected is a process known as “radiation darkening”. This is another effect of long-term exposure to solar radiation without the filtering properties of the Earth’s atmosphere and magnetic field. As the name suggests, radiation darkening is where materials become darker in color as a result of prolonged exposure to radiation. This effect has been documented in the laboratory and also on the surface of the Moon. The crew of Apollo 12 set down in close proximity to the landing site of one of NASA’s robotic lunar spacecraft—Surveyor 3. As part of their scheduled EVA activities, the crew removed several parts from Surveyor and returned them to Earth for scientific study, including ties made of nylon. When these ties were examined, it was found that they had been discolored by the radiation, changing from white to tan. At the time of the Apollo 12 mission, the Surveyor spacecraft had been on the lunar surface for 942 Earth days—just over 2 ½ years. The first flag placed on the Moon on July 20, 1969 has been there for over 40 years. Surely it, too, has experienced this darkening effect and would now be seen in shades of tan and brown.³⁷

Yet another threat to the lunar flags is damage by meteoroids or micrometeoroids. Meteoroids are solid objects traveling through space that are too small to be classified as either an asteroid or as a comet. On Earth, most meteoroids burn up in the atmosphere, but on the Moon they regularly hit the surface. Most discussion of meteoroid impacts with regards to lunar exploration focuses on those that are smaller than 1 mm in diameter—the micrometeoroids. These tiny projectiles (about 1/4 the size of a bb used in air rifle) travel at very high velocity—about 13–18 kilometers per second (or 13,000–18,000 m/sec). This is 130–180 times faster than an air rifle propels a bb. In the event that one of the particles hit a flag standing on the lunar surface it would most likely pass right through the fabric. Even at the time of the Apollo 11 mission a “high NASA official” told a reporter from *Business Week* that the flag probably wouldn’t last long because “it isn’t protected against micrometeoroids”.³⁸

Conclusion

Whether the flags have remained standing or have survived decades of exposure to the harsh lunar environment, their legacy as a symbol of the human exploration of space remains intact. Images of the Apollo astronauts standing next to the United States flag on the Moon are not just a testament to the technological achievements of the U.S., but rather are illustrations of what the human species can achieve when our efforts are directed to the exploration of our solar system. Clearly, the significance of these images will endure long after the deaths of those who participated in this historic undertaking.



Figure 42: Geologist-astronaut Harrison H. Schmitt poses in one of the Apollo Program's most artistic flag photographs. The crossbar of the lunar flag assembly appears to be pointing to the gibbous planet Earth. This was the last flag left by astronauts on the lunar surface. NASA Photo AS17-134-20384 (December 1972).

Perhaps the most troubling aspect of the moon landing hoax conspiracy theories is that they cast doubt not just on the Apollo Program, but on the entire legacy of human space exploration. It is important to remember that Apollo was not just an American program. Instead, it was a continuation of the visions of rocket engineers from different countries such as Konstantin Tsiolkovsky, Hermann Oberth, Robert H. Goddard, Sergei Korolev, and Wernher von Braun. The space race may have been born out of the Cold War between East and West, but it produced a science and technology revolution that has advanced global technology and brought the people of the world closer together. In addition, denying the historical validity of the Apollo moon landings is disrespectful to the memories of the Soviet cosmonauts and American astronauts who lost their lives in the efforts to expand the reach of humanity beyond low Earth orbit to the surface of the Moon. And, Kaysing's suggestion that some of these astronauts were murdered to cover up a conspiracy to fake the moon landings is not only insulting, it is libelous.



Figure 43: Apollo 15 astronauts left this memorial on the Moon during their mission. It includes a sculpture called “Fallen Astronaut” and a plaque memorializing Soviet cosmonauts and NASA astronauts who had died in pursuit of human exploration of space. NASA Photo AS15-88-11894 (1 August 1971).

For those of us who have confidence in the reality of the moon landings it is difficult to understand why people would believe these claims. Many in the space industry conclude that it is a symptom of inadequate education or a complete lack of scientific literacy on the part of the general public. However, belief in the lunar landing hoax is really not as prevalent as the conspiracy theorists would suggest. It is likely that these conspiracy theories are just a reflection of our popular culture, in general. People are often distrustful of government and technology, especially when they don't know much about how these things work. Plus, the culture of self-publishing, self-produced video, and the ease of distributing this information via the Internet all contribute to the perception that belief that the moon landings were faked is not only prevalent, but is also spreading.

As has been shown in this paper, the claims of the conspiracy theorists lose their plausibility when they are carefully examined and analyzed. There are clear scientific and technical explanations for the “discrepancies” that the hoax believers cling to and use as evidence. Examining the design of the lunar flag assembly, it is quite obvious why flags appear to be “fluttering” on the surface of the Moon—the flagpoles were designed specifically to give this impression. When we think about basic principles of physics and how they are manifested in the videos from the Apollo missions it is clear that the flags are moving either because astronauts are handling the flag, or because an astronaut has set them in motion and they are still in motion due to the law of inertia. And we also have learned how easy it is for someone to misinterpret what they see in lunar photographs or in a video frame viewed out of context. As vexillologists we regularly try to sift through the legends and folklore associated with flags in order to find the historical realities. It is important that we document and defend the documented history of important “flag moments” such as the placing of the first flags on the Moon. It is also vital that we share this information beyond the community of vexillologists so that people can understand the true significance of these moments in human history.

It is hoped that this paper will not only contribute more evidence for the defense of the historical record, but will also remind the readers of the true significance of the flags on the Moon. Admittedly, the choice of the American flag for implantation during the Apollo missions was rooted in patriotism. However, NASA went out of its way to explain that “the planting of the flag is symbolic of the first time man has landed on another celestial body and does not constitute a territorial claim by the United States”. In a newspaper article published in August 1969, a reporter commented on positive reactions found among people in countries around the world. He cites the words of a German writer saying that “she didn't think of the rocket as taking three Americans into space but rather the human species and she thanked America for doing it for mankind.” Besides the flag of exploration, perhaps the most meaningful object left on the Moon during Apollo 11 was the plaque mounted on the ladder of the lunar module. It read “Here men from the planet Earth first set foot upon the Moon July 1969, A.D. We came in peace for all mankind”.³⁹

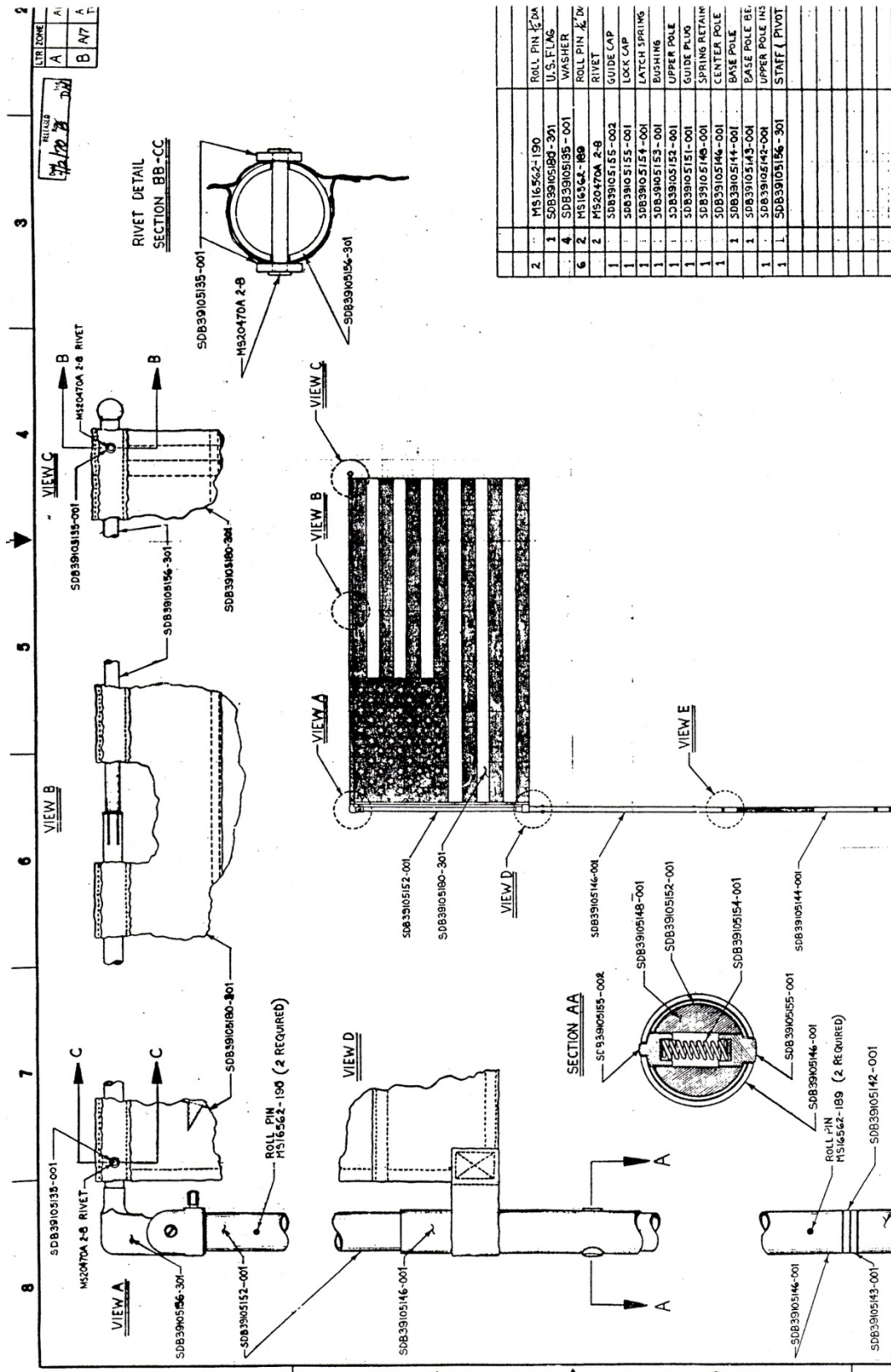
Author's Statement of Bias

It is important for scholars to recognize and acknowledge their biases when conducting and reporting on research. I freely admit to a bias in the case of moon landing hoax theories. Having grown up watching the Apollo missions on television and maintaining a life-long interest in space exploration, I fully believe in the historical validity of the Apollo moon landings. When I worked as a contractor employee at NASA's Johnson Space Center I met a number of Apollo-era engineers, took a "clean room" tour of the Lunar Sample Laboratory Facility where lunar samples are stored and studied, and even met two of the twelve men who walked on the surface of the Moon. I also experienced the university-like atmosphere of the space center, where keeping a secret of the magnitude of "faking the moon landings" would not only improbable, but also impossible.

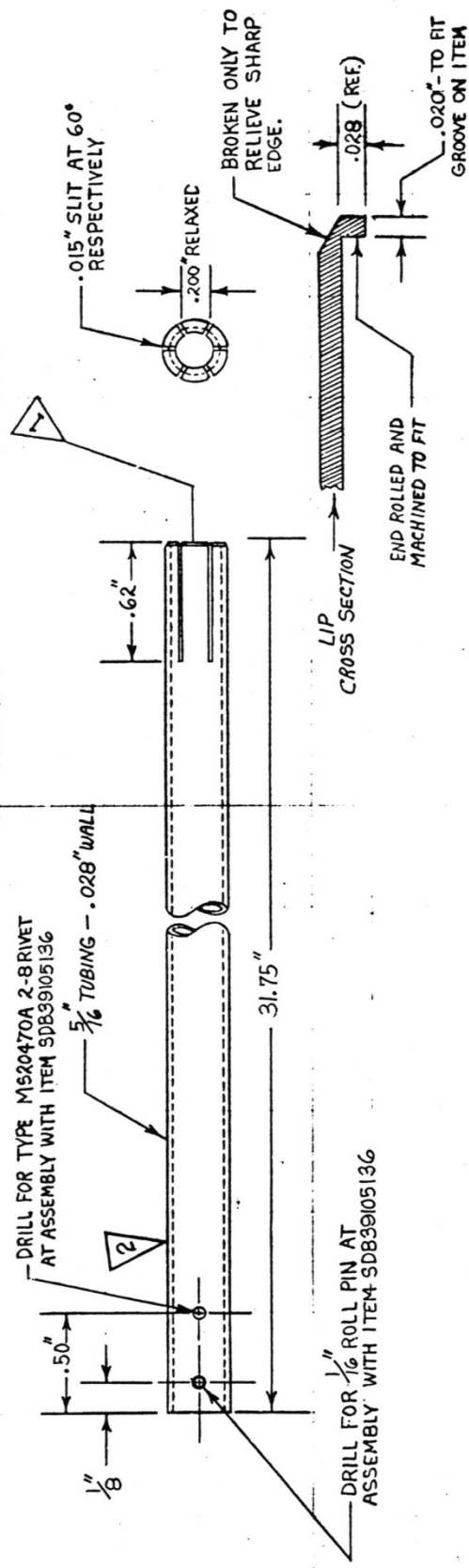


Figure 44: The author (standing, center) with colleagues during a tour of the Lunar Sample Laboratory Facility at NASA's Johnson Space Center in 1994. During the tour she viewed some of the samples returned to Earth by the Apollo astronauts, including core samples which were being analyzed at the time.

Appendix A: NASA Engineering Drawings of the Lunar Flag Assembly



4	3	2	1
RELEASED		REVISION	
LTR ZONE		DATE	
A/R		1/10/70	
I. CHANGED NEXT ASSY. NO. FROM SDB39105157 TO SDB39105156		APPROVAL	
Date: 1/12/70		[Signature]	



- 3 ALODINE INTERIOR SURFACE PER MIL-C-5541 CLASS III GRADE C TYPE I.
- 2 GOLD ANODIZE PER MIL-A-8625C, TYPE II, CLASS 2 (EXTERIOR SURFACE)
- 1 POLISH INTERIOR OF TUBE PRIOR TO ANODIZING
- 1 APPLY NEXT ASSY. PART NO. BY ELECTRO-CHEM ETCH (SDB39105156-3XX) PER MSC M-I

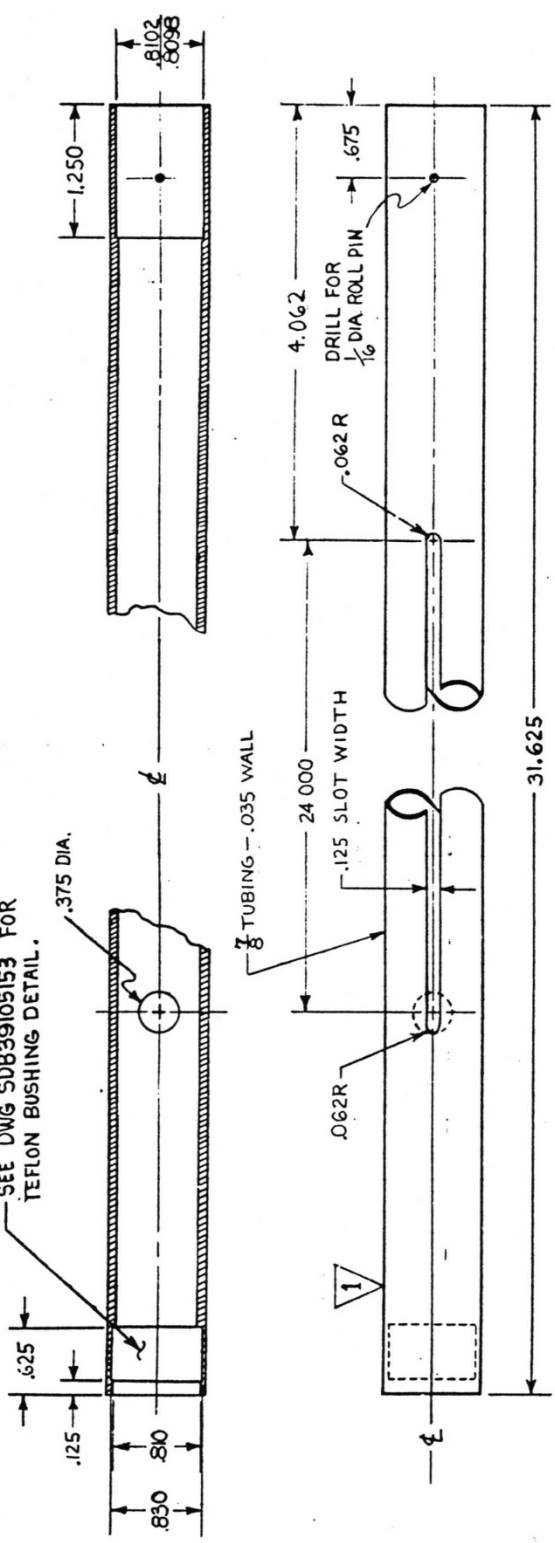
REDUCED

1	-001	HORIZONTAL STAFF	AL. 6061-T6	WW-T-799BI WW-T-700/6A2
PART NUMBER		DESCRIPTION	MATERIAL	SPECIFICATION
SURFACE FINISH IN MICROINCHES RMS UNLESS NOTED OTHERWISE		SIGNATURES	NATIONAL AERONAUTICS AND SPACE ADMINISTRATION MANNED SPACECRAFT CENTER HOUSTON, TEXAS	
63		DR. N. S. WARENCY 12/69	HORIZONTAL STAFF, FLAG ASSY-PROJECT APOLLO	
DIMENSIONAL TOLERANCE UNLESS NOTED OTHERWISE		ENG. T. KINZLER 1/1/69	CODE IDENT NO. SIZE	
.0 ± .10		CH. J. H. [Signature] 1-12-70	21356 B	
.00 ± .02		AP. [Signature] 1/1/69	DWS NO. SDB39105134	
ANGULAR ±		APP. [Signature] 1/1/69	SCALE N	
SDB39105156		NEXT ASSEMBLY		
NEXT ASSEMBLY		BH TECH SRV SHEET		

MC Form 1818 B-1 (REV. OCT. 65)

4	3	2	1	REVISION	DATE	APPROVAL
				LTR ZONE		
		A	C-1	CHANGED .810 DIMENSION TO .8102	12-30-69	<i>[Signature]</i>
		B		CHANGED SPECIFICATIONS FROM QQ-A-259/114 TO QQ-A-225/B TO WW-T-700/6	1/5/70	<i>[Signature]</i>

THIS AREA REAMED FOR CAPTIVE BUSHING, SEE DWG SDB39105153 FOR TEFLON BUSHING DETAIL.

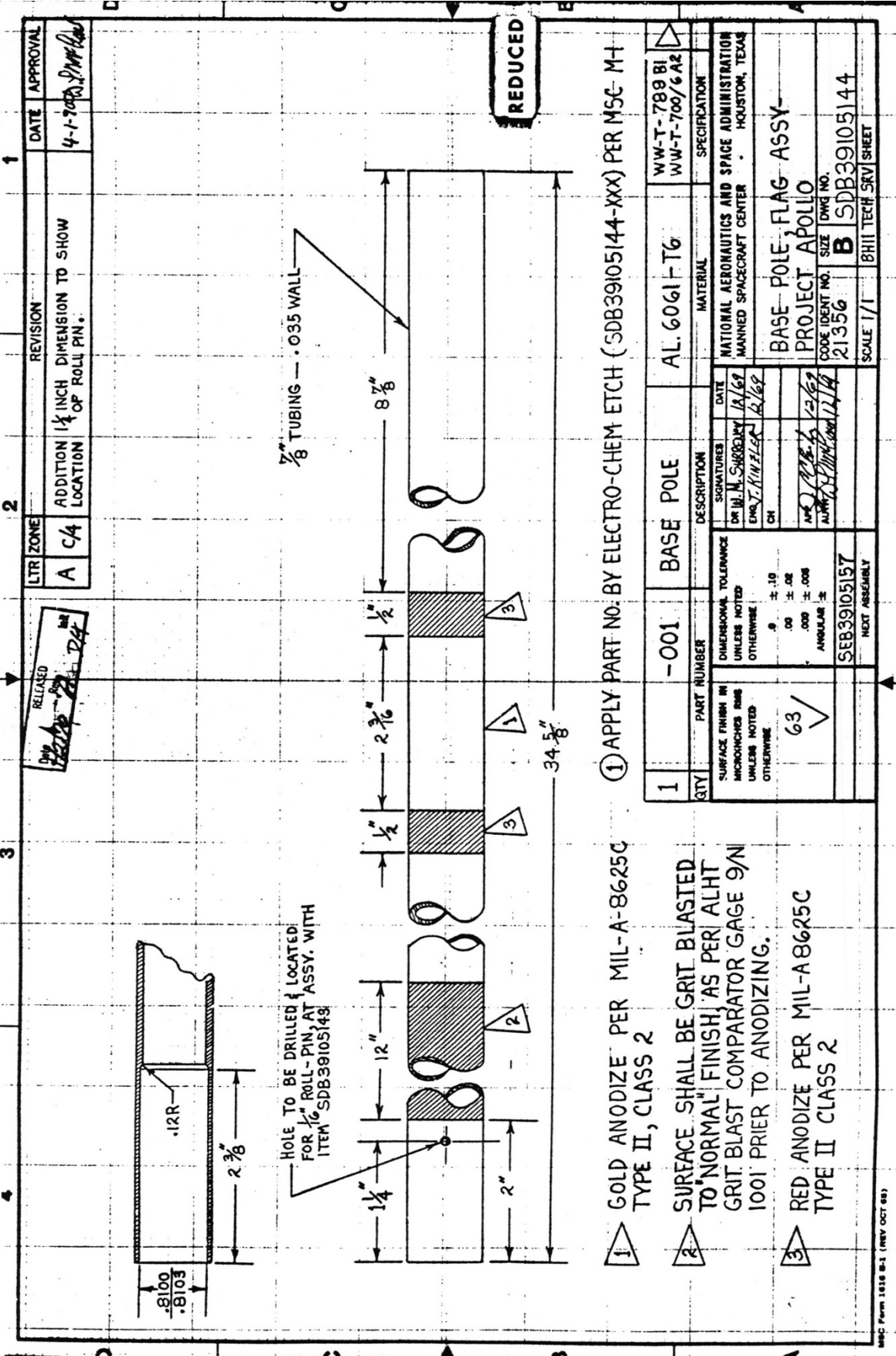


REDUCED

① GOLD ANODIZE PER MIL-A-8625C TYPE II, CLASS 2

NOTE ① APPLY PART NO. BY ELECTRO-CHEM ETCH (SDB39105146-XXX) AND ASSY. NO. (SDB39105157-3XX) SERIAL NO. XXX AS PER MSC SPEC M-1

QTY	1	PART NUMBER	-001	DESCRIPTION	CENTER POLE	MATERIAL	AL. 6061-T6	SPECIFICATION	WW-T-700/6
SURFACE FINISH IN MICROINCHES RMS UNLESS NOTED OTHERWISE		DIMENSIONAL TOLERANCE UNLESS NOTED OTHERWISE		SIGNATURES		NATIONAL AERONAUTICS AND SPACE ADMINISTRATION MANNED SPACECRAFT CENTER HOUSTON, TEXAS			
.0 ± .10		.000 ± .008		DR	A. R. RILEY	CENTER POLE, FLAG ASSY - PROJECT APOLLO			
.00 ± .02		ANGULAR ±		CH	J. WHEELER	CODE IDENT NO. 21356			
63/		SEB39105157		APR	[Signature]	SIZE B			
		NEXT ASSEMBLY		AUG	[Signature]	SCALE 1/1			
						SDB39105146			
						BH TECH SRV SHEET			



① APPLY PART NO. BY ELECTRO-CHEM ETCH (SDB39105144-XXX) PER MSC-MH

1 GOLD ANODIZE PER MIL-A-8625C TYPE II, CLASS 2

2 SURFACE SHALL BE GRIT BLASTED TO "NORMAL" FINISH, AS PER ALHT GRIT BLAST COMPARTOR GAGE 9/N 1001 PRIOR TO ANODIZING.

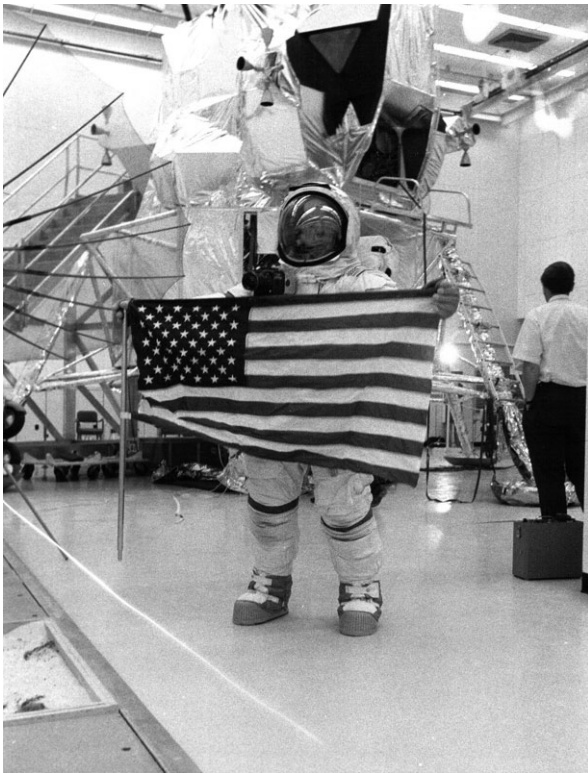
3 RED ANODIZE PER MIL-A-8625C TYPE II CLASS 2

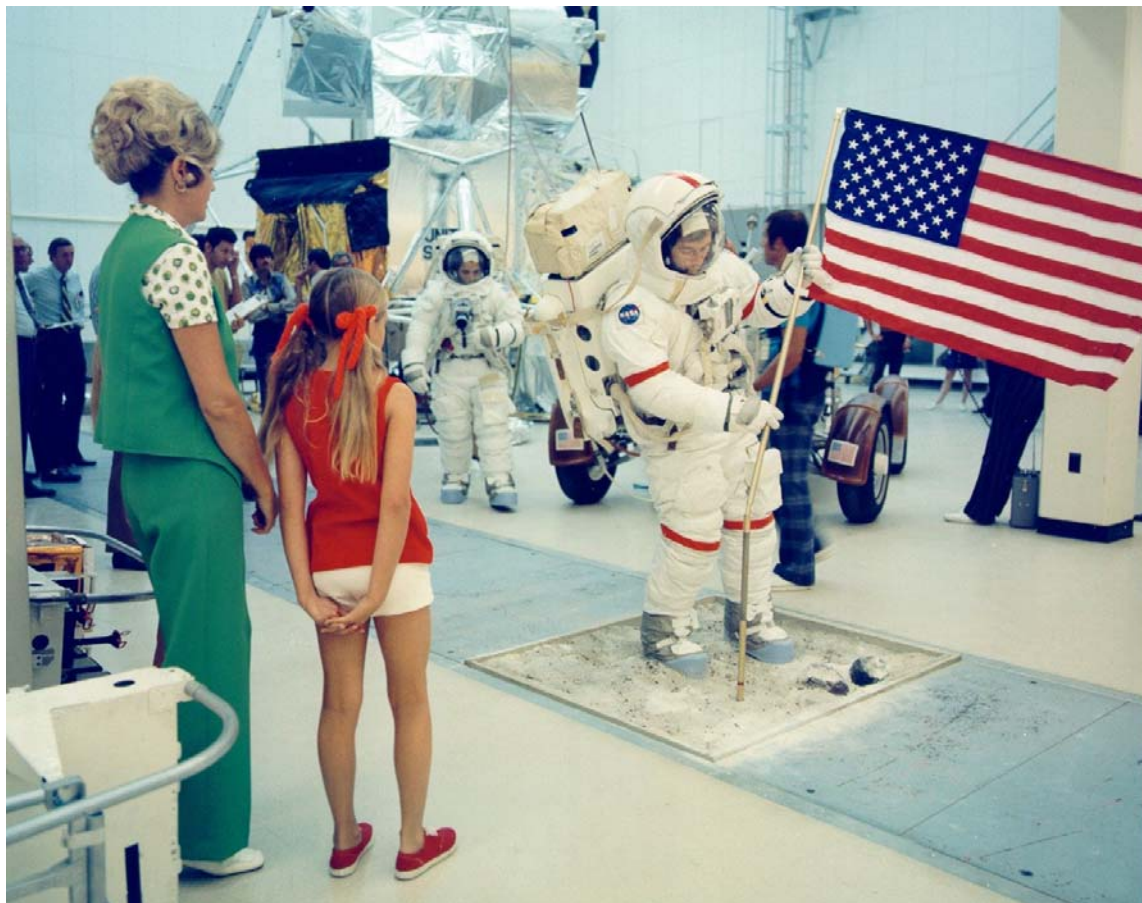
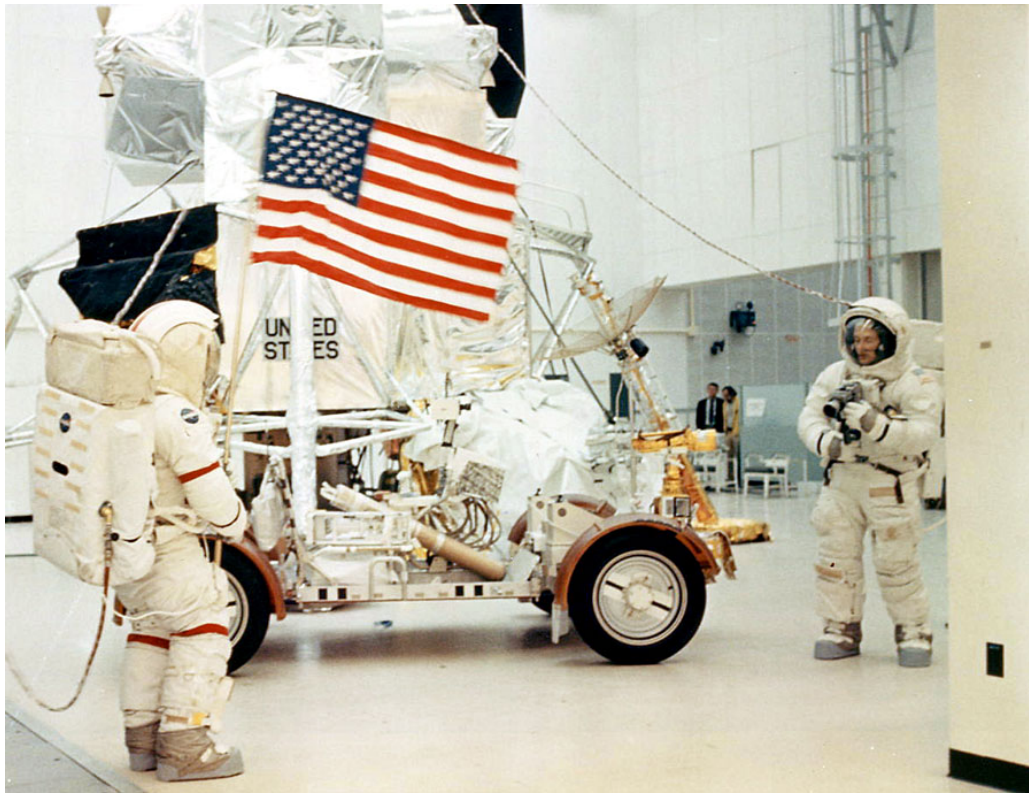
REDUCED

1	DATE APPROVAL	4-1-70
2	REVISION	ADDITION 1/4 INCH DIMENSION TO SHOW LOCATION OF ROLL PIN.
3	REL. DATE	4-1-70
4	LTR ZONE	A C/A

1	QTY	1	PART NUMBER	-001	DESCRIPTION	BASE POLE	MATERIAL	AL 6061-T6	SPECIFICATION	WW-T-789 BI WW-T-709/6A2
SURFACE FINISH IN MICROINCHES RMS UNLESS NOTED OTHERWISE		DIMENSIONAL TOLERANCE UNLESS NOTED OTHERWISE		SIGNATURES		DATE		NATIONAL AERONAUTICS AND SPACE ADMINISTRATION MANNED SPACECRAFT CENTER HOUSTON, TEXAS		
63		.000 ± .005 ANGULAR ±		DR. M. S. GREGORY ENG. J. K. FLEET CH		12/69 12/69		BASE-POLE, FLAG ASSY- PROJECT APOLLO		
SEB39105157		NEXT ASSEMBLY		APPROVED BY JAMES R. HARRIS		12/69		CODE IDENT NO. SIZE DWG NO. 21356 B SDB39105144		
				DRAWN BY JAMES R. HARRIS		12/69		SCALE 1/1 BIII TECH SRV SHEET		

Appendix B: Apollo Program Astronaut Training Photographs





Illustrations

Figure 1: Cropped photo—Neil Armstrong and flag (Apollo 11). NASA Photo AS11-40-5886, 20 July 1969. Available online at <http://history.nasa.gov/alsj/a11/AS11-40-5886HR.jpg>.

Figure 2: Charles Conrad, Jr. and flag (Apollo 12). NASA Photo AS12-47-6897, 19 November 1969. Available online at <http://spaceflight.nasa.gov/gallery/images/apollo/apollo12/html/as12-47-6897.html>.

Figure 3: Alan B. Shepard, Jr. and flag (Apollo 14). NASA Photo AS14-66-9231, 5 February 1971. Available online at <http://history.nasa.gov/alsj/a14/AS14-66-9232HR.jpg>.

Figure 4: David R. Scott, and flag (Apollo 15). NASA Photo AS15-88-11863, 1 August 1971. Available online at <http://spaceflight.nasa.gov/gallery/images/apollo/apollo15/html/as15-88-11863.html>.

Figure 5: Charles M. Duke, Jr. and flag (Apollo 16). NASA Photo AS16-113-18341, 21 April 1972. Available online at <http://history.nasa.gov/alsj/a16/AS16-113-18341HR.jpg>.

Figure 6: Eugene A. Cernan and flag (Apollo 17). NASA Photo AS17-134-20386, 13 December 1972. Available online at <http://spaceflight.nasa.gov/gallery/images/apollo/apollo17/html/as17-134-20386.html>.

Figure 7: Lunar flag assembly and lunar module (Apollo 14). NASA Photo AS14-66-9277, 5 February 1971. Available online at <http://spaceflight1.nasa.gov/gallery/images/apollo/apollo14/html/as14-66-09277.html>.

Figure 8: James B. Irwin and flag (Apollo 15). NASA Photograph AS15-88-11866, 1 August 1971. Available online at <http://spaceflight.nasa.gov/gallery/images/apollo/apollo15/html/as15-88-11866.html>.

Figure 9: Eugene A. Cernan and flag (Apollo 17). NASA Photograph AS17-134-20380, 13 December 1972. Available online at <http://spaceflight.nasa.gov/gallery/images/apollo/apollo17/html/as17-134-20380.html>.

Figure 10: Neil A. Armstrong and Edwin E. “Buzz” Aldrin, Jr. with the flag (Apollo 11). NASA Photograph S69-40308, 20 July 1969. Available online at http://spaceflight.nasa.gov/gallery/images/apollo/apollo11/html/s69_40308.html.

Figure 11: “Buzz” Aldrin with the flag (Apollo 11). NASA Photograph AS11-40-5874, 20 July 1969. Available online at http://spaceflight.nasa.gov/gallery/images/apollo/apollo11/html/as11_40_5874.html.

Figure 12: Cropped photo—Charles M. Duke, Jr. and the lunar rover (Apollo 16). NASA Photograph AS16-107-17446, 22 April 1972. Available online at <http://spaceflight.nasa.gov/gallery/images/apollo/apollo16/html/as16-107-17446.html>.

Figure 13: Cropped photo—David R. Scott and flag (Apollo 15). NASA Photograph AS15-88-11863, 1 August 1971. Available online at <http://spaceflight.nasa.gov/gallery/images/apollo/apollo15/html/as15-88-11863.html>.

Figure 14: Buzz Aldrin saluting the flag (Apollo 11). NASA Photo AS11-40-5874, 20 July 1969. Available online at http://spaceflight.nasa.gov/gallery/images/apollo/apollo11/html/as11_40_5874.html.

Figure 15: Buzz Aldrin with flag (Apollo 11). NASA Photograph AS-11-40-5875, 20 July 1969. Available online at http://spaceflight.nasa.gov/gallery/images/apollo/apollo11/html/as11_40_5875.html.

Figure 16: Extracted video frame—John Young and Charles Duke (Apollo 16). 21 April 1972. Extracted from the video at <http://www.hq.nasa.gov/alsj/a16/a16v.1201951.mpg>.

Figure 17: John Young with the flag (Apollo 16). NASA Photograph AS16-113-18339, 21 April 1972. Available online at <http://spaceflight.nasa.gov/gallery/images/apollo/apollo16/html/as16-113-18339.html>.

Figure 18: Figure 17—cropped and rotated 90° horizontally using Photoshop software.

Figure 19: Extracted video frame—Flag and other equipment left on the Moon (Apollo 14). Image extracted and labeled by Robert Godwin. Obtained from Robert Godwin.

Figure 20: Extracted video frame—Flag and other equipment left on the Moon (Apollo 14). Image extracted and labeled by Robert Godwin. Obtained from Robert Godwin.

Figure 21: Original sketch for the lunar flagpole. Obtained from Jack Kinzler.

Figure 22: NASA engineering drawing for the lunar flag assembly, Drawing Number SEB39105157. Obtained from NASA Johnson Space Center.

Figure 23: Components of the lunar flag assembly. NASA JSC Photo S69-38748, 1969. Obtained from NASA JSC Media Resource Center.

Figure 24: NASA engineer demonstrating deployment of the lunar flag assembly. NASA JSC Photo S69-38755, 1969. Obtained from NASA JSC Media Resource Center.

Figure 25: NASA engineer demonstrating deployment of the lunar flag assembly. NASA JSC Photo S69-38756, 1969. Obtained from NASA JSC Media Resource Center.

Figure 26: NASA engineer demonstrating deployment of the lunar flag assembly. NASA JSC Photo S69-38757, 1969. Obtained from NASA JSC Media Resource Center.

Figure 27: NASA engineer demonstrating deployment of the lunar flag assembly. NASA JSC Photo S69-38758, 1969. Obtained from NASA JSC Media Resource Center.

Figure 28: NASA engineer demonstrating deployment of the lunar flag assembly. NASA JSC Photo S69-38759, 1969. Obtained from NASA JSC Media Resource Center.

Figure 29: NASA engineer demonstrating deployment of the lunar flag assembly. NASA JSC Photo S69-38760, 1969. Obtained from NASA JSC Media Resource Center.

Figure 30: NASA engineer demonstrating deployment of the lunar flag assembly. NASA JSC Photo S69-38761, 1969. Obtained from NASA JSC Media Resource Center.

Figure 31: NASA engineer demonstrating deployment of the lunar flag assembly. NASA JSC Photo S69-38762, 1969. Obtained from NASA JSC Media Resource Center.

Figure 32: NASA engineer demonstrating deployment of the lunar flag assembly. NASA JSC Photo S69-38763, 1969. Obtained from NASA JSC Media Resource Center.

Figure 33: NASA engineers pack the lunar flag assembly for the Apollo 11 mission. NASA JSC Photo S69-38765, 1969. Obtained from NASA JSC Media Resource Center.

Figure 34: NASA engineers pack the lunar flag assembly for the Apollo 11 mission. NASA JSC Photo S69-38766, 1969. Obtained from NASA JSC Media Resource Center.

Figure 35: NASA engineers pack the lunar flag assembly for the Apollo 11 mission. NASA JSC Photo S69-38767, 1969. Obtained from NASA JSC Media Resource Center.

Figure 36: NASA engineers pack the lunar flag assembly for the Apollo 11 mission. NASA JSC Photo S69-38768, 1969. Obtained from NASA JSC Media Resource Center.

Figure 37: NASA engineers pack the lunar flag assembly for the Apollo 11 mission. NASA JSC Photo S69-38769, 1969. Obtained from NASA JSC Media Resource Center.

Figure 38: NASA engineers pack the lunar flag assembly for the Apollo 11 mission. NASA JSC Photo S69-38770, 1969. Obtained from NASA JSC Media Resource Center.

Figure 39: Lunar Reconnaissance Orbiter image of the Apollo 17 landing site. Available online at http://www.nasa.gov/images/content/397621main_ap17_1st50km_4release.jpg.

Figure 40: Portion of Figure 39, enlarged for detail. Available online at http://www.nasa.gov/images/content/397622main_challenger_4x.jpg.

Figure 41: Extracted video frame—flag movement during liftoff from the Moon (Apollo 14). NASA Photo S71-19500, 5 February 1971. Available online at <http://images.jsc.nasa.gov/luceneweb/caption.jsp?photoId=S71-19500>.

Figure 42: Harrison H. Schmitt with flag (Apollo 17). NASA Photo AS17-134-20384, December 1972. Available online at <http://spaceflight.nasa.gov/gallery/images/apollo/apollo17/html/as17-134-20384.html>.

Figure 43: Cropped photo—“Fallen Astronaut” sculpture and memorial plaque left on the Moon. NASA Photo AS15-88-11894, 1 August 1971. Available online at <http://spaceflight.nasa.gov/gallery/images/apollo/apollo15/html/as15-88-11894.html>.

Figure 44: The author with colleagues during a tour of the Lunar Sample Laboratory Facility at NASA’s Johnson Space Center, 1994. Photo from collection of the author.

Appendix A: NASA Engineering Drawings of the Lunar Flag Assembly

Page 861: Flag Assembly, Drawing Number SEB39105157. Obtained from NASA Johnson Space Center.

Page 862: Horizontal Staff, Flag Assembly, Drawing Number SDB39105134. Obtained from NASA Johnson Space Center.

Page 863: Center Pole, Flag Assembly, Drawing Number SDB39105146. Obtained from NASA Johnson Space Center.

Page 864: Base Pole, Flag Assembly, Drawing Number SDB39105144. Obtained from NASA Johnson Space Center.

Appendix B: Training Photographs of Astronauts and the Lunar Flag Assembly

Because both astronauts were required to deploy the flags on the Moon, the best photographs that show astronauts handling the parts of the flag come from training photographs. Notice how the gloves of their spacesuits limit their ability to grasp the flags.

Page 865: Training photographs of the Apollo 14 Crew

Top left: Al Shepard pulls the top of the U.S. flag taut during training for Apollo 14. NASA Photo AP14-70-H-1119. Available at <http://next.nasa.gov/alsj/a14/ap14-70-H-1119.jpg>.

Top right: Al Shepard photographs Ed Mitchell and the flag during indoor EVA training (July 1970). NASA Photo S70-46153. Available at <http://next.nasa.gov/alsj/a14/ap14-S70-46153HR.jpg>.

Bottom: Ed Mitchell (left) goes toward the LM mockup while Al Shepard works with the telescoping crossbar at the top of the flag during Apollo 14 training. NASA Photo AP14-Apollo14-KSC-noID. Available at <http://next.nasa.gov/alsj/a14/ap14-Apollo14-KSC-noID.jpg>.

Page 866: Training photographs of the Apollo 16 and Apollo 17 Crews

Top: John Young (left) holds the US flag while Charlie Duke (right) prepares to take pictures during training for Apollo 16 (22 November 1971). NASA Photo S72-15788. Available at <http://www.hq.nasa.gov/alsj/a16/ap16-S72-15788.jpg>.

Bottom: Gene Cernan deploys the U.S. Flag during training for Apollo 17 while his wife and daughter watch. Jack Schmitt is in the background. (4 August 1972). NASA Photo KSC-72PC-379. Available at <http://www.hq.nasa.gov/alsj/a17/ap17-KSC-72PC-379HR.jpg>.

Footnote 26:

Original sketch for alternative lunar flagpole design that was rejected by NASA management. Miniature flags of all nations would have been displayed on the rods below the United States flag. From the files of Jack Kinzler.

Notes

For information on image numbers and sources, see the Illustrations list.

¹ William David Compton, *Where No Man Has Gone Before: A History of Apollo Lunar Exploration Missions* (Washington, DC: NASA, 1989), NASA SP-4214, Appendix 5, p. 361–366; Andrew Chaikin, *A Man on the Moon: The Voyages of the Apollo Astronauts* (New York: Viking, 1994), p. 596–599; United States, National Aeronautics and Space Administration, “Curation: Lunar Samples”, <http://curator.jsc.nasa.gov/lunar/index.cfm>, accessed 27 March 2011.

² Anne M. Platoff, “Where No Flag Has Gone Before: Political and Technical Aspects of Placing a Flag on the Moon”, NASA Contractor Report 188251 (Houston, TX: NASA Johnson Space Center, August 1993), available online at http://ntrs.nasa.gov/archive/nasa/casi.ntrs.nasa.gov/19940008327_19940008327.pdf. This paper was also published in vol. 1 of *Raven: A Journal of Vexillology* (1994), p. 3–10. The NASA version includes an appendix with several of the NASA engineering drawings of the lunar flag assembly that are not available in the *Raven* version.

Since the publication of this original work, I have found one mistake that should be corrected. In the introduction I stated that “NASA’s spacecraft and launch vehicles have always been decorated with flags.” This statement was, in fact, an over-generalization. It would have been more accurate to state that “Nearly all of NASA’s manned spacecraft have been decorated with flags.” As discussed in my history of the use of flags in the U.S. manned space program, all U.S. manned spacecraft except the first two Mercury capsules have had flags on them. For more information, see: Anne M. Platoff, “Flags in Space: NASA Symbols and Flags in the U.S. Manned Space Program”, published as no. 230 of *The Flag Bulletin*, vol. 46 #5–6 (issue dated September–December 2007, published December 2010), p. 172–175.

Another thing that is important to note about this early work is that it was primarily about the Apollo 11 flag. I have learned a great deal more about the flags of all the Apollo missions since I wrote that paper. See the “Design and

Construction of the Lunar Flag Assembly” of this paper for updated information about the lunar flag assemblies on all Apollo missions.

³ “Bill Kaysing,” *Wikipedia: the Free Encyclopedia*, http://en.wikipedia.org/wiki/Bill_Kaysing, accessed 12 April 2011; Bill Kaysing and Randy Reid, *We Never Went to the Moon* ([Fountain Valley, Calif.?] : Eden Press, 1976); Bill Kaysing and Randy Reid, *We Never Went to the Moon: America’s 30 Billion Dollar Swindle!* (Cornville, AZ: Desert Publications, 1981); A. Bowdoin Van Riper, “Moon Landings,” in *Conspiracy Theories in American History: an Encyclopedia*, vol. 2 (Santa Barbara, CA: ABC CLIO, 2003), p. 500–503; Roger D. Launius, “Denying the Apollo Moon Landings: Conspiracy and Questioning in Modern American History,” AIAA 2010-1131, paper presented at the 48th AIAA Aerospace Sciences Meeting including the New Horizons Forum and Aerospace Exposition (4–7 January 2010, Orlando, Florida), available online at <http://www.smithsonianconference.org/apollo/wp-content/uploads/2009/10/Denying-the-Apollo-Moon-Landings.pdf>, accessed 20 October 2010; Johann Hari, “Conspiracy Theories: A Guide,” *New Statesman*, v. 131 #4618 (16–30 December 2002), p. 27; “Moon Landing Conspiracy Theories,” *Wikipedia: the Free Encyclopedia*, http://en.wikipedia.org/wiki/Moon_landing_hoax, accessed 5 May 2011; Philip C. Plait, *Bad Astronomy: Misconceptions and Misuses Revealed, from Astronomy to the Moon Landing “Hoax”* (New York: John Wiley & Sons, Inc., 2002), p. 157.

⁴ Kaysing, *We Never Went to the Moon* (1981 edition), entire book, but especially p. 31–50; Robert A. Braeunig, “Did We Land on the Moon?: A Debunking of the Moon Hoax Theory”, *Rocket & Space Technology*, <http://www.braeunig.us/space/hoax.thm>, accessed 12 April 2011, [p. 16–17].

⁵ [Ralph] René, *NASA Mooned America!* (Passaic, N.J.: [self-published], 1992); Mary Bennett and David S. Percy, *Dark Moon: Apollo and the Whistle-Blowers* (Kempton, Illinois: Adventures Unlimited Press, 1999); A. I. Popov, *Amerikantsy na lune: Velikii propyv ili kosmicheskaiia aferu?* (Moscow: Veche, 2009); Iurii Mukhin, *Antiapollon: Lunnaia aferu SShA* (Moscow: Iauza/Eksmo, 2005).

⁶ Bill Kaysing, Daryl Carstensen, Ross Marshall, and Randy Reid, “We Never Went to the Moon,” VHS video (Plutonium Films Productions, 1995); “Dark Mission 1—NASA Moon Hoax,” *YouTube* video, <http://www.youtube.com/watch?v=yo5w0pm24ic>, accessed 12 April 2011; Aron Ranen, “Did We Go?”, VHS video, [Santa Monica, CA?]: Third Wave Media, 1999.

⁷ “Moon Landing Conspiracy Theories,” *Wikipedia: the Free Encyclopedia*, http://en.wikipedia.org/wiki/Moon_landing_hoax, accessed 12 April 2011; David Bowdley, “Hollywood Goes to the Moon: the Greatest Hoax of Them All?”, *Physics Education*, v. 38 #5 (September 2003), p. 406–412; “Conspiracy Theory: Did We Land on the Moon?”, in *IMDb: The Internet Movie Database*, <http://www.imdb.com/title/tt0277642/>, accessed 12 April 2011; John Moffet (director), “Conspiracy Theory: Did We Land on the Moon?”, aired on the Fox network, 15 February 2001, viewed on *YouTube* in several parts, 5 March 2011: part 1 - <http://www.youtube.com/watch?v=Y5MVVtFYTS0>, part 2 - http://www.youtube.com/watch?v=b309_YspwMk, part 3 - <http://www.youtube.com/watch?v=R1CpNoI4WGc>, part 4 - <http://www.youtube.com/watch?v=n8qzDJwYjro>, part 5 - <http://www.youtube.com/watch?v=ZiCKy41zZMU>.

⁸ Kaysing, p. 1; “Opinion Polls About Conspiracy Theories,” in *Conspiracy Theories in American History: An Encyclopedia*, ed. by Peter Knight (Santa Barbara, Calif.: ABC CLIO, 2003), vol. 2, p. 561–564; “Did Men Really Land on the Moon? Fox TV Special Questions Moon Landing, but Public Says ‘No’ to Conspiracy Theory”, *Gallup News Service*, 15 February 2001, <http://www.gallup.com/poll/1993/Did-Men-Really-Land-Moon.aspx>, accessed 4 February 2011; Frank Newport, “Landing a Man on the Moon: The Public’s View: Majority Thinks Space Program has Been Worth it, Although Only Half Remember Neil Armstrong’s Name”, 20 July 1999, *Gallup News Service*, 15 February 2001, <http://www.gallup.com/poll/3712/Landing-Man-Moon-Publics-View.aspx>, accessed 4 February 2011; Steve Dutch, “Conspiracy Theory: Did We Go to the Moon?”, website in response to the Fox television special, <http://www.uwgb.edu/dutchs/pseudosc/conspiracytheorydidwegotothemoon.htm>, accessed 4 March 2011, [p. 1]; Plait, p. 156; Launius, p. 3, 7–10.

“Thinking about space exploration, do you think the government staged and faked the Apollo moon landings, or don’t you feel that way?”, question from Time/CNN poll, dated 21 July 1995, located in the *Polling the Nations*

database, accessed 20 October 2010; “Thinking about the space exploration, do you think the government staged or faked the Apollo moon landing, or don’t you feel that way?”, question from a Gallup poll, dated 20 July 1999, located in the *Polling the Nations* database, accessed 20 October 2010; “In 1969, NASA broadcast live TV footage of astronaut Neil Armstrong’s walk on the moon. To this day, some people believe the moon landing was a made-for-television special effects production, and man has never actually landed on the moon. What is your opinion?”, question from a Zogby International poll, dated 25 May 2001, located in the *Polling the Nations* database, accessed 20 October 2010.

⁹ A. S. Petrova, “Byli li amerikantsy na lune?”, 19 April 2000, *Baza dannykh FOM*, http://bd.fom.ru/report/cat/sci_sci/kosmos/of001605, accessed 5 May 2011; Piers Bizony, “It Was All a Fake, Right?”, *Engineering & Technology*, v. 4 #12 (11 July–24 July 2009), p. 24–25; Ein kosmischer Streit: Hat die erste Mondlandung überhaupt stattgefunden?, *Der Spiegel Online Forum*, <http://www1.spiegel.de/active/vote/fcgi/vote.fcgi?voteid=1060>, accessed 15 May 2011.

¹⁰ National Aeronautics and Space Administration, “Did U.S. Astronauts Really Land on the Moon?”, *NASA Facts*, originally issued June 1977, reissued 14 February 2001, http://www.grc.nasa.gov/WWW/K-12/DLN/descriptions/docs/SBreachlunar_landing.pdf, accessed 15 May 2011; Ray Villard, “Did NASA Fake the Moon Landing?”, *Astronomy*, v. 32 #7 (July 2004), p. 48–53; “Mashing Moon Myths”, *Science*, v. 312 #5773, p. 505; Bowdley, p. 406–412; Bizony, p. 24–25; David D. Perlmutter and Nicole Smith Dahmen, “(In)visible Evidence: Pictorially Enhanced Disbelief in the Apollo Moon Landings”, *Visual Communication*, v. 7 #2 (2008), p. 229–251; Johann Hari, “Conspiracy Theories: A Guide”, *New Statesman*, v. 131 #4618 (16–30 December 2002), p. 27; A. Bowdoin Van Riper, “Moon Landings”, in *Conspiracy Theories in American History: An Encyclopedia*, ed. by Peter Knight (Santa Barbara, Calif.: ABC CLIO, 2003), vol. 2, p. 500–503; Kim Poor, “Carl Sagan, Where Are You? The Moon Hoax”, *Ad Astra*, v. 13 #6 (November/December 2001), p. 38–39; Plait, p. 153–173; Launius, “Denying the Apollo Moon Landings: Conspiracy and Questioning in Modern American History”, AIAA Paper 2010–1131; James Oberg, “Lessons of the ‘Fake Moon Flight’ Myth”, *Skeptical Inquirer*, v. 27 #2 (March/April 2003), p. 23, 30, http://www.csicop.org/si/show/lessons_of_the_fake_moon_flight_myth, accessed 15 May 2011; Dutch, “Conspiracy Theory: Did We Go to the Moon?”; “The Great Moon Hoax: Moon Rocks and Common Sense Prove Apollo Astronauts Really Did Visit the Moon”, NASA website, http://science.nasa.gov/science-news/science-at-nasa/2001/ast23feb_2/, accessed 9 April 2011; Brent Silby, “Of Course We Went to the Moon: A Defense of the Lunar Landings...”, <http://www.def-logic.com/articles/lunarlanding.html>, accessed 15 May 2011; Braeunig, “Did We Land on the Moon?: A Debunking of the Moon Hoax Theory”; “Top Ten Busted Myths”, *Skeptic*, v. 15 #4 (1 June 2010), p. 74; Lanius; “NASA Moon Landing,” *MythBusters*, episode 104, originally aired on the Discovery Channel, 27 August 2008.

Ironically, Richard Hoagland, a NASA critic and conspiracy theorist who claims that NASA is covering up evidence of alien artifacts it has found on the Moon and on Mars, acknowledges that the moon landing hoax theorists are making “naïve and absurd” claims. Hoagland and his co-author of *Dark Mission: The Secret History of the National Aeronautics and Space Administration* wrote that “most of the charges made by these ‘Moon Hoax’ advocates are so absurd, so easily discredited and so lacking in any kind of scientific analysis (and just plain common sense) that they give legitimate conspiracy theories (like ours) a bad name.” They then suggest that “NASA carefully planned, from the beginning, to give those folks a ‘conspiracy,’ alright, but—a fake conspiracy ... to cover up the real one.” Richard C. Hoagland and Michael Bara, *Dark Mission: The Secret History of the National Aeronautics and Space Administration* (Los Angeles: Feral House, 2007), p. 172–173.

¹¹ Kaysing, p. 32–35, 183; René, p. 10–11; Mukhin, p. 95–96, 307–322; “Space Vehicles: The Blast Crater”, *Moon Base Clavius*, <http://www.clavius.org/techcrater.html>, accessed 29 May 2011; Dutch, [p. 2, 5–6], Bizony, p. 24; Plait, p. 163–165; Braeunig, [p. 10–11]; Perlmutter and Dahmen, p. 241–242.

¹² Kaysing, p. 47–49, 192; Bennett and Percy, p. 50–54, 65; Mykhin, p. 256–265; René, p. 29–36, 145–146; Dutch, [p. 1], “The Great Moon Hoax”, [p. 2]; Bizony, p. 25; “Top Ten Busted Myths”, p. 74; Poor, p. 38–39; Plait, p. 158–160; Bowdley, p. 408; Lanius, p. 5; Braeunig, [p. 3]; Perlmutter and Dahmen, p. 238–239.

“Why is the Sky Blue?,” *How Stuff Works*, <http://science.howstuffworks.com/nature/climate-weather/atmospheric/sky.htm>, accessed 5 May 2011. As explained in the “Atmosphere” section of “The Lunar

Environment” chapter of the *Lunar Sourcebook*, the Moon actually does have an atmosphere primarily composed of neon, hydrogen, helium, and argon. However, the lunar atmosphere is very tenuous (meaning weak or slight). The concentration of gas molecules in the lunar atmosphere is estimated to be about 2×10^5 molecules/cm³ at night, and falls to about 104 molecules/cm³ during the lunar day as temperatures increase. Molecules lost due to heating are replaced by new ones, mostly derived from the solar wind. Because the atmosphere on the Moon is about 14 orders of magnitude less than that on Earth, from a terrestrial perspective it is commonly said that the Moon has no atmosphere. David Vaniman, Robert Reedy, Grant Heiken, Gary Olhoeft, and Wendell Mendell, “The Lunar Environment,” in *Lunar Sourcebook: A User’s Guide to the Moon* (New York: Cambridge University Press, 1991), p. 27–60.

One of the best refutations of the “no stars” argument can be found on the *Moon Base Clavius* website. Their page on “Photography: Stars in the Sky” explains why stars are not visible in the Apollo lunar photographs. Their “Photography: Exposure” page explains that the word “exposure” (as used in photography) is the combination of the aperture setting (often referred to as the “f-stop”), which controls how much light is allowed to reach the film, and the shutter speed, which controls how long the camera’s shutter is open. This same page also notes that “Photography on the lunar surface presents two problems. First, the sunlight is quite bright. The moon is roughly as far away from the sun as the earth, but there is no atmosphere to filter and subdue the sunlight. And along with this is the glare of the sun off the lunar surface... Second, the difference between light and shadow is more pronounced on the Moon since there is no atmosphere to scatter the sunlight and make it more uniform.” “Photography: Stars in the Sky” *Moon Base Clavius*, <http://www.clavius.org/stars.html>, accessed 5 May 2011; “Photography: Exposure” *Moon Base Clavius*, <http://www.clavius.org/photoexp.html>, accessed 5 May 2011.

¹³ Kaysing, p. 43–46, 183, 192; Bennett and Percy, p. 16–49; René, p. 8–9, 143–145; Mukhin, p. 235–251; “Moon”, *Wikipedia: the Free Encyclopedia*, <http://en.wikipedia.org/wiki/Moon>, accessed 5 May 2011; “Photo Analysis: Indirect Light”, *Moon Base Clavius*, <http://www.clavius.org/indlight.html>, accessed 5 May 2011; “Photo Analysis: Pride Run Amok”, *Moon Base Clavius*, <http://www.clavius.org/decal.html>, accessed 5 May 2011. A highly technical explanation of the Moon’s “albedo” (defined by the *Oxford Dictionary of English* as “the proportion of the incident light or radiation that is reflected by a surface, typically that of a planet or moon”) can be found in the *Lunar Sourcebook*. W. David Carrier III, Gary R. Olhoeft, and Wendell Mendell, “Physical Properties of the Lunar Surface,” in *Lunar Sourcebook: A User’s Guide to the Moon* (New York: Cambridge University Press, 1991), p. 560–561. For an excellent analysis of the Apollo 16 “Jump Salute” photograph, see the page devoted to this topic on the *Moon Base Clavius* site. “Photo Analysis: Jump Salute”, *Moon Base Clavius*, <http://www.clavius.org/jumpsal.html>, accessed 5 May 2011. “Beta cloth”, *Wikipedia: the Free Encyclopedia*, http://en.wikipedia.org/wiki/Beta_cloth, accessed 5 May 2011; “Photography: Glowing Flags” *Moon Base Clavius*, <http://www.clavius.org/glowflag.html>, accessed 14 May 2011; Dutch, [p. 3]; Bizony, p. 25; Plait, p. 167–172; Bowdley, p. 409; Braeunig, [p. 3–4]; Silby, [p. 4–6]; Perlmutter and Dahmen, p. 239–240.

¹⁴ Kaysing, p. 43–46; Bennett and Percy, p. 16–49; Mukhin, p. 233–251, 268–270, 303–306; “Photo Analysis: Converging Shadows”, *Moon Base Clavius*, <http://www.clavius.org/a11rear.html>, accessed 5 May 2011; “Photo Analysis: Shadow Lengths”, *Moon Base Clavius*, <http://www.clavius.org/shadlen.html>, accessed 5 May 2011; “Photo Analysis: Perspective and Shadows”, *Moon Base Clavius*, <http://www.clavius.org/perspshdw.html>, accessed 5 May 2011; “Photo Analysis: Shadows at 15 Degrees”, *Moon Base Clavius*, <http://www.clavius.org/shad15.html>, accessed 5 May 2011; “Photo Analysis: Shadows at 30 Degrees”, *Moon Base Clavius*, <http://www.clavius.org/shad30.html>, accessed 5 May 2011; “Photo Analysis: Shadows at 45 Degrees”, *Moon Base Clavius*, <http://www.clavius.org/shad45.html>, accessed 5 May 2011; Dutch, [p. 3]; Bizony, p. 25; Plait, p. 167–172; Bowdley, p. 409; Braeunig, [p. 3–4]; Silby, [p. 4–6]; “NASA Moon Landing,” *MythBusters*, episode 104.

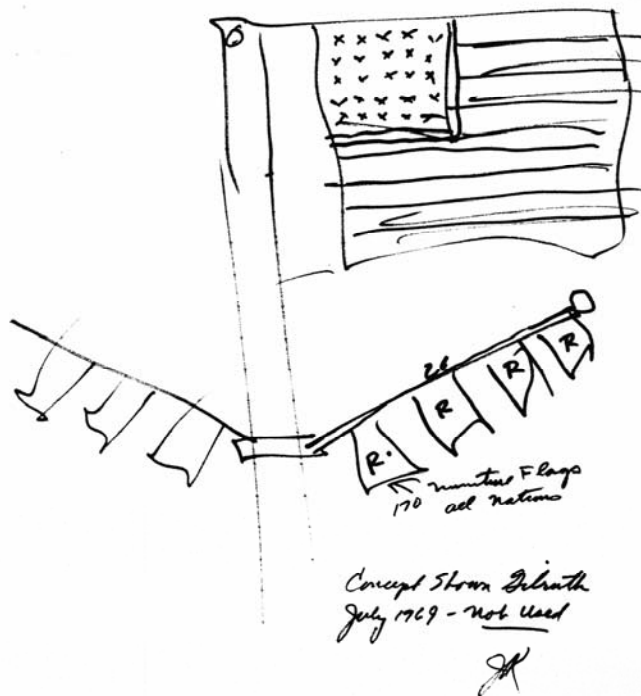
A video compilation of the DAC images from Apollo 11 which show the flag-raising can be downloaded from the Apollo 11 Video Library website at <http://www.hq.nasa.gov/alsj/a11/video11.html>; the video URL is <http://www.hq.nasa.gov/alsj/a11/a11f1093740.mov>. Before leaving the lunar module for the extravehicular activity, astronaut Aldrin had set the Data Acquisition Camera (DAC) to record one frame per second. At about 29 minutes and 30 seconds into the video, the astronauts enter the frame and begin to set up the lunar flag assembly. Following deployment (about 33 minutes, 40 seconds) you can see Neil Armstrong back up to take some still photos of Buzz Aldrin and the flag. Note: there is no sound for this video.

-
- ¹⁵ Bennett and Percy, p. 67–68; Mukhin, p. 265–268; “Photo Analysis: Crosshairs”, *Moon Base Clavius*, <http://www.clavius.org/photoret.html>, accessed 14 May 2011; Dutch, [p. 3–5]; Braeunig, [p. 6]; Silby, [p. 6–7]; Perlmutter and Dahmen, p. 240.
- ¹⁶ Dutch, [p. 10–12]; “The Great Moon Hoax”, [p. 3–6]; Poor, p. 38–39; Lanius, p. 6; Braeunig, [p. 14–15]; “NASA Moon Landing,” *MythBusters*, episode 104.
- ¹⁷ Bill Kaysing and Randy Reid, *We Never Went to the Moon*; “Conspiracy Theory: Did We Land on the Moon?” (video, viewed on *YouTube*, part 3); Mukhin, p. 7, 81–84, 270–274; Dutch, [p. 2]; “The Great Moon Hoax”, [p. 2–3]; Bizony, p. 24; Bowdley, p. 408–409; Silby, [p. 1–3]; Perlmutter and Dahmen, p. 244–245.
- ¹⁸ Mukhin, p. 40–41, 81–84, 270–274; “Top Ten Busted Myths”, p. 74; Braeunig, [p. 6–7]. The “Moon Landing Conspiracy Theories” article on *Wikipedia* includes an animated gif combining two images of Buzz Aldrin (NASA Photograph AS11-40-5874 and NASA Photograph AS-11-40-5875)—see <http://en.wikipedia.org/wiki/File:AldrinFlag-animation.gif>. A full array of images from Apollo 11 can be viewed on the Apollo 11 Image Library offered through the NASA Headquarters website at <http://www.hq.nasa.gov/alsj/a11/images11.html#Mag37>.
- ¹⁹ “Conspiracy Theory: Did We Land on the Moon?” (video, viewed on *YouTube*, part 3).
- ²⁰ NASA, Solar System Exploration, “Comparison: Earth’s Moon vs. Earth”, <http://solarsystem.nasa.gov/planets/compchart.cfm?Object1=Moon>, accessed 10 May 2011; “Moon”, *Wikipedia*; “Top Ten Busted Myths”, p. 74.
- ²¹ Mukhin, p. 270–274; “NASA Moon Landing,” *MythBusters*, episode 104. Apollo video footage can be downloaded from the NASA’s *Lunar Surface Journal* website at <http://www.hq.nasa.gov/alsj/alsj-video.html>. Apollo 14 flag raising (Shepard and Mitchell erect flag on lunar surface), http://www.hq.nasa.gov/office/pao/History/alsj/ktclips/ap14_flag.mpg; Apollo 16 astronaut jumps and salutes flag, http://www.hq.nasa.gov/office/pao/History/alsj/ktclips/ap16_salute.mpg; and Apollo 17 astronauts with flag, http://www.hq.nasa.gov/office/pao/History/alsj/ktclips/ap17_flag.mpg.
- ²² Video of the Apollo 15 flag movement can be viewed at <http://www.hq.nasa.gov/alsj/a15/a15v.1485548.mpg> or <http://www.hq.nasa.gov/alsj/a15/a15v.1485548.rm>. Eric M. Jones, “EVA-2 Closeout”, *Apollo 15 Lunar Surface Journal*, <http://www.hq.nasa.gov/alsj/a15/a15.clsout2.html>, accessed 23 June 2011; Shane Killian, “More Moon Stupidity—Apollo 15 Flag”, *YouTube* video, <http://www.youtube.com/watch?v=GbjvgqoeFSU>, accessed 23 June 2011; “Waving Flag in Apollo 15 (thread)”, *Bad Astronomy and Universe Today Forum*, <http://www.bautforum.com/showthread.php/64524-Waving-Flag-in-Apollo-15>, accessed 23 June 2011; Jarrah White, “Initial Apollo 15 Flag Movement”, *YouTube* video, <http://www.youtube.com/watch?v=dW9qcL4LiUg>, accessed 23 June 2011.
- ²³ Bennett and Percy, p. 43–44; Mukhin, p. 270–274; “Parallax”, *Wikipedia: the Free Encyclopedia*, <http://en.wikipedia.org/wiki/Parallax>, accessed 14 May 2011; Braeunig, [p. 5].
- ²⁴ Images extracted from Apollo 14 mission video courtesy of Robert Godwin, personal communication to the author, 13 May 2011; follow-up communication, 18 May 2011. Peter Rakobowchuk, “Images of American Flag Taken by Apollo 14 Astronauts Provide Fuel for Conspiracists”, *Winnipeg Free Press*, http://www.winnipegfreepress.com/arts-and-life/life/sci_tech/images-of-american-flag-taken-by-apollo-14-astronauts-provide-fuel-for-conspiracists---119140354.html, posted 3 April 2011, accessed 13 May 2011; Michael Lennick, “Fox News Bungles Apollo 14 Story— Turns it into a Moon Hoax Story” *Science for the Win!* [blog], <http://scienceforthewin.blogspot.com/2011/04/fox-news-bungles-apollo-14-story-turns.html> (posted 3 April 2011), accessed 13 May 2011; “How Did the Apollo Astronauts Toss Their Spacesuits Overboard?”, *Air & Space Smithsonian* website, <http://www.airspacemag.com/need-to-know/NEED-ApolloSuits.html>, posted 1 January 2007, accessed 22 May 2011.

²⁵ Godwin, personal communication to the author, 13 May 2011; “Canadian Publisher Fuels Argument That Apollo 14 Lunar Missions Were a Hoax”, original text of the Fox News story that remained on their site *Fox News.mobi*, <http://us.foxnews.mobi/quickPage.html?page=26048&content=50264167&pageNum=-1>, found on 13 May 2011; “CORRECTION: Canadian Publisher Examines Apollo Pictures: Answers Conspiracy Theorists”, *Fox News.com*, <http://www.foxnews.com/us/2011/04/03/canadian-publisher-questions-images-american-flag-taken-apollo-14-astronauts/>, accessed 13 May 2011; Rakobowchuk, “Images of American Flag Taken by Apollo 14 Astronauts Provide Fuel for Conspiracists”; Lennick, “Fox News Bungles Apollo 14 Story - Turns it into a Moon Hoax Story”; “Images of American Flag Taken by Apollo 14 Astronauts Actually Provide Evidence for Hoax!”, Ray Alex Website, <http://reinep.wordpress.com/2011/04/11/images-of-american-flag-taken-by-apollo-14-astronauts-actually-provide-evidence-for-hoax/>, posted 11 April 2011, accessed 13 April 2011.

²⁶ Platoff, “Where No Flag Has Gone Before: Political and Technical Aspects of Placing a Flag on the Moon”; Jack Kinzler, NASA Manned Spacecraft Center (renamed Johnson Space Center in 1973), Chief of Technical Services (retired), interview with the author, 30 August 1992; Jack Kinzler’s notes on weights of flags and hardware, from the files of Jack Kinzler; “Apollo 11 Flags”, NASA Press Release 69-83E (3 July 1969).

During my interview with Jack Kinzler, he showed me another flag pole design proposal that had been rejected by NASA authorities (see image below). This pole design featured a large American flag at the top with smaller horizontal rods mounted below. The idea was to display miniature flags of all nations below the larger flag. Anyone with any knowledge of flag protocol can guess at one reason why this design was not used. It would have violated a basic tenet of flag etiquette, which states that when two or more national flags are displayed together they should be of equal size and flown at equal heights. There are technical considerations, though, that also made this design less practical. It would have more complicated to construct and deploy, and it would probably have weighed more.



Original sketch for alternative lunar flagpole design that was rejected by NASA management. Miniature flags of all nations would have been displayed on the rods below the United States flag.

²⁷ Platoff, “Where No Flag Has Gone Before: Political and Technical Aspects of Placing a Flag on the Moon”; Jack Kinzler, interview; “Apollo 11 Flags”, NASA Press Release 69-83E (3 July 1969).

²⁸ Platoff, “Where No Flag Has Gone Before: Political and Technical Aspects of Placing a Flag on the Moon”; Jack Kinzler, interview; “Apollo 11 Flags”, NASA Press Release 69-83E (3 July 1969); *Apollo 13 Press Kit*, NASA Press Release 70-50K (2 April 1970) p. 73; *Apollo 14 Press Kit*, NASA Press Release 71-3K (21 January 1971), p. 86; *Apollo 15 Press Kit*, NASA Press Release 71-119K (15 July 1971), p. 129; *Apollo 16 Press Kit*, NASA Press Release 72-64K (6 April 1972), p. 137.

²⁹ Jack Kinzler, interview; Jack Kinzler’s notes on weights of flags and hardware, from the files of Jack Kinzler; *Apollo 13 Press Kit*, NASA Press Release 70-50K (2 April 1970) p. 73; *Apollo 14 Press Kit*, NASA Press Release 71-3K (21 January 1971), p.86; *Apollo 15 Press Kit*, NASA Press Release 71-119K (15 July 1971), p. 129; *Apollo 16 Press Kit*, NASA Press Release 72-64K (6 April 1972), p. 137.

³⁰ If you look at Kinzler’s sketch of the lunar flag assembly (see Figure 21) you will see that he included notations for the flag size as 28 inches x 54 inches (or 2.5 x 4 feet). However, in my interview with Kinzler he clearly stated that a 3 x 5 foot flag was used. This is also backed up by the press release and my photographic analysis. In addition, the Smithsonian Institution has a replica Apollo 11 flag in their collection that is also 3 x 5 feet. Their other two lunar flag assemblies (including one which was used as a training article for the astronauts) use flags that are 2.5 x 4 feet. Apollo 11: Platoff, “Where No Flag Has Gone Before: Political and Technical Aspects of Placing a Flag on the Moon”; Jack Kinzler, interview; “Apollo 11 Flags”, NASA Press Release 69-83E (3 July 1969); Allan Needell, Curator, Space History Division, National Air and Space Museum, Smithsonian Institution, personal communications with the author, 4 May 2011 and 16 June 2011.

Apollo 12–16: *Apollo 12 Press Kit*, NASA Press Release 69-148 (5 November 1969), p. 5; *Apollo 13 Press Kit*, NASA Press Release 70-50K (2 April 1970) p. 5, 73; *Apollo 14 Press Kit*, NASA Press Release 71-3K (21 January 1971), p.5, 86; *Apollo 15 Press Kit*, NASA Press Release 71-119K (15 July 1971), p. 6, 129; *Apollo 16 Press Kit*, NASA Press Release 72-64K (6 April 1972), p. 5, 137.

³¹ *Apollo 17 Press Kit*, NASA Press Release 72-220K (26 November 1972); “Apollo 17 Flag to Fly in MOCR”, *Space News Roundup* (newspaper of the Johnson Space Center), v. 13 #2 (21 December 1973), p. 1; Eric M. Jones, “ALSEP Off-load (Corrected Transcript and Commentary)”, *Apollo Lunar Surface Journal*, <http://www.hq.nasa.gov/alsj/a17/a17.alsepoff.html>, last revised 30 October 2010, accessed 18 June 2011, see the section for ground elapsed time (GET) 118:18:34 through 118:26:45.

³² Platoff, “Where No Flag Has Gone Before: Political and Technical Aspects of Placing a Flag on the Moon”; Jack Kinzler, interview.

³³ David S. F. Portree, “Flag on the Moon,” radio script and background information, *Earth and Sky*, aired 11 December 2001, <http://web.archive.org/web/20031224223134/http://earthsky.org/2001/es011211.html>, originally accessed 21 June 2002, accessed via web archive 24 May 2011; Joe Roberts, “Can you see the Flag on the Moon with a Telescope?”, *Amateur Astronomer’s Notebook*, http://www.rocketroberts.com/astro/flag_on_moon.htm, updated 3 October 2009, accessed 23 May 2011; Fraser Cain, “Flag on the Moon”, *Universe Today*, <http://www.universetoday.com/19932/flag-on-the-moon/>, posted 22 October 2008, accessed 23 May 2011; Braeunig, [p. 14].

³⁴ “Exploration of the Moon”, *Wikipedia: the Free Encyclopedia*, http://en.wikipedia.org/wiki/Lunar_exploration, accessed 16 April 2011; “Lunar Reconnaissance Orbiter”, *Wikipedia: the Free Encyclopedia*, http://en.wikipedia.org/wiki/Lunar_Reconnaissance_Orbiter, accessed 16 April 2011; “LRO Sees Apollo Landing Sites”, http://www.nasa.gov/mission_pages/LRO/multimedia/lroimages/apollosites.html, posted 17 July 2009, accessed 16 April 2011; Mark Robinson, “Exploring the Apollo 17 Site”, <http://lroc.sese.asu.edu/news/index.php?archives/137-Exploring-the-Apollo-17-Site.html>, accessed 16 April 2011; “Apollo 17 Lunar Module Landing Site”, *Lunar Reconnaissance Orbiter* website, http://www.nasa.gov/mission_pages/LRO/multimedia/lroimages/lroc_20091028_apollo.html, 28 October 2009, accessed 11 June 2011; David Morrison, “Moon Hoax Resolved: New Lunar Orbiter Images Show Moon Landers, Astronauts’ Tracks”, *Skeptical Inquirer* v. 33 #6 (November/December 2009), p. 5-6.

³⁵ “Apollo 11 Technical Crew Debriefing,” 31 July 1969, vol. 1, p. 10-43 and 10-45, on file in the JSC History Collection; “Apollo 11 Postflight-Crew Press Conference,” 12 August 1969, p. 40C/1, transcript on file in the JSC History Collection; Edgar M. Cortright, *Apollo Expeditions to the Moon*, NASA SP-350 (Washington, DC: NASA, 1975), p. 216; Edwin E. Aldrin, Jr., “Lunar Dust Smelled Just Like Gunpowder,” *Life*, v. 67 no. 8 (22 August 1969), p. 26; Charles R. Pellegrino and Joshua Stoff, *Chariots for Apollo: the Making of the Lunar Module* (New York: Atheneum, 1985), p. 179; Buzz Aldrin, *Men From Earth* (New York: Bantam Books, 1989), p. 242; David S. F. Portree, “Flag on the Moon,”; Andrew Chaikin, *A Man on the Moon* (New York: Penguin, 1994), p. 224. Note: When I originally accessed materials in the JSC History Collection they were held by the History Office at NASA’s Johnson Space Center. They have since been transferred to the library at the University of Houston—Clear Lake.

Video footage from Apollo 14 (JSC-563, reference master 118476) and from Apollo 16 (AK-113) showed that the flags from those missions remained standing after liftoff. Footage from other missions did not show enough to conclude anything about the condition of the flag after the ascent module left the surface. See also Platoff, “Where No Flag Has Gone Before,” fn. 15.

³⁶ Much of the information in this section was originally presented in my history of the use of flags in the U.S. manned space program. See: Anne M. Platoff, “Flags in Space: NASA Symbols and Flags in the U.S. Manned Space Program”, published as no. 230 of *The Flag Bulletin*, vol. 46 #5–6 (issue dated September–December 2007, published December 2010), p. 172–175.

The issue of sun rot is of great interest to the manufacturers of flags. Nylon is a polyamide and, like other plastics, deteriorates when exposed to ultraviolet radiation such as that in sunlight. Tests conducted by DuPont, the manufacturer of SolarMax® nylon, compared the weathering of flags flown at test locations in Florida, Arizona, and California for a 12-month period. The sample flags in Florida and California showed severe fading after 7–9 months and experienced mechanical failure at 10 months. In Arizona, the flags in the test failed mechanically at 4 months before severe fading was noticed at 7 months. In all cases, flags made of this “sun resistant” fabric did not survive for an entire year. What does this study tell us about the outlook for the flags on the moon? On one hand, the lunar flags are not exposed to wind and moisture—elements that certainly contributed to the deterioration of the flags in the DuPont study. However, the levels of UV on the lunar surface are significantly higher than those at the terrestrial sites. The key element that is present on Earth and not on the moon is oxygen, but studies of photodegradation of nylon in a nitrogen environment have shown that oxygen is not required for this chemical process to occur.

Portree, “Flag on the Moon”; Y.W. Mai, D. R. Head, B. Cotterell, and B. W. Roberts, “Mechanical Properties of Nylon 6 Subjected to Photodegradation”, *Journal of Materials Science* v. 15 (1980), p. 3057-3065; G. A. Horsfall, “Factors Influencing the Daylight Photodegradation of Nylon 66, Nylon 6, and Polyester in Commercial Fabrics”, *Textile Research Journal*, v. 52 (1982), p. 197–205; Y. Fujiwara, “Formation of Cracks on Photodegraded Nylon 6 Filaments”, *Journal of Applied Polymer Science*, v. 27 (1982), p. 2773–2782; “Polyamides, Plastics: Environmental Effects—Ultraviolet Radiation,” in Herman Mark, et. al., *Encyclopedia of Polymer Science and Engineering* (New York: John Wiley and Sons, 1988), vol. 11, p. 467; DuPont, “Sunlight Photodegradation of Textile Fibers and Fabrics,” web page, <http://web.archive.org/web/20040309040240/http://www.dupont.com/solarmax/html/photodeg.html>, originally accessed 16 July 2002, accessed via web archive 24 May 2011; DuPont, “Outdoor Weathering Flag Test Program,” web pages, <http://web.archive.org/web/20040308183349/http://www.dupont.com/solarmax/html/flagtest.html>, originally accessed 16 July 2002, accessed via web archive 24 May 2011, entry page and links to flag test results; Vaniman, et. al., “The Lunar Environment,” in *Lunar Sourcebook: A User’s Guide to the Moon*, p. 40–45.

³⁷ Portree, “Flag on the Moon”; *Analysis of Surveyor 3 Material and Photographs Returned by Apollo 12* (Washington, D.C.: NASA, 1972), p. iii, 1–13, 17, 23–29, 60, 94–96; C. V. Stephenson, B. C. Moses, and W. S. Wilcox, “Ultraviolet Irradiation of Plastics: I. Degradation of Physical Properties”, *Journal of Polymer Science*, v. 55 (1961), p. 451–464; Vaniman, et. al., “The Lunar Environment,” in *Lunar Sourcebook: A User’s Guide to the Moon*, p. 47–56.

³⁸ David S. F. Portree, “Flag on the Moon”; “Of 195 Flags Going to Moon, One Stays,” *Business Week* (19 July 1969), p. 105; Vaniman, et. al., “The Lunar Environment,” in *Lunar Sourcebook: A User’s Guide to the Moon*, p. 45–47.

³⁹ Donald C. Drake, “Flag on Moon Offers an Example for Man”, *Philadelphia Inquirer* (10 August 1969), copy on file at the NASA Headquarters History Office; “Apollo 11 Flags”, NASA Press Release 69-83E (3 July 1969).

About the Author

Anne “Annie” Platoff is a science librarian at the University of California, Santa Barbara Library. In this capacity, she teaches university students how to conduct research and how to evaluate critically the information they find. She often uses conspiracy theories in her teaching as examples of the need for critical thinking. Before working in academic libraries, she worked as a librarian for the New Initiatives Office and the Exploration Programs Office at the National Aeronautics and Space Administration’s (NASA) Johnson Space Center in Houston, Texas. In this capacity, she provided research services to scientists, engineers, and program managers who were planning future missions to the Moon and to Mars.

As a vexillologist Annie has conducted research on a variety of topics. A native of the state of Kansas, she presented her first paper to NAVA in 1989, reporting on proposed designs for the state flag of Kansas. She also presented and published a paper on the Pike-Pawnee Flag Incident—an event during which some believed that Zebulon Pike had planted the first American flag in Kansas, but which Annie demonstrated had actually occurred in Nebraska (published in *Raven: A Journal of Vexillology*, vol. 6). Annie has also completed a thorough history of the symbols of NASA and the use of flags in the U.S. manned space program (published as a special double issue of *The Flag Bulletin*, No. 230, vol. 46, # 5–6). In addition she published a paper titled “Where No Flag Has Gone Before: Political and Technical Aspects of Placing a Flag on the Moon”, which was published in volume 1 of *Raven* and as a NASA Contractor Report (NASA-CR-188251). A long-time student of the Russian language, Annie is also interested in the vexillology of the Russian Federation and the Soviet Union. She has published a book on the flags of Russia’s federal subjects (published as vol. 16 of *Raven*) and an article on Soviet Children’s flags (in *Raven*, vol. 17). At the NAVA 44 meeting, she presented a paper on the “Forward Russia” Flag and the changing use of the bear as a symbol of Russia (awaiting publication). She also authored an article for the *NAVA News* on the World Flag of the Girl Guides and Girl Scouts. Annie has twice been awarded the Captain William Driver award for the best paper presented at a NAVA meeting, and received FIAV’s Vexillon for her book *Russian Regional Flags*.

Annie is currently completing a third term as NAVA’s second vice president. In this capacity she is overseeing the completion of the NAVA Digital Library, a project designed to provide all issues of *NAVA News* and *Raven: A Journal of Vexillology* online. The project will also include a revamp of NAVA’s online index to enable users to search for articles on specific topics and then link through to the full text. Her formal education includes a Bachelor of Arts degree in political science and history from Kansas State University, a Master of Science degree in library science from the University of North Texas, a Master of Arts degree in historical studies from the University of Houston—Clear Lake, and a graduate certificate in museum studies from Arizona State University. Her master’s thesis, a history of NASA’s early planning for manned Mars missions, was published by NASA in 2001 (NASA CR-2001-208928).



At the 24th International Congress of Vexillology, FIAV President Michel Lupant and Secretary-General Charles Spain present the *Vexillon* to Anne M. Platoff for her 2009 work *Russian Regional Flags*.