

**UCLA**

**On-Line Working Paper Series**

**Title**

Quarter Tables Revisited: Earlier Tables, Division of Labor in Table Construction, and Later Implementations in Analog Computers

**Permalink**

<https://escholarship.org/uc/item/5n31064n>

**Author**

McFarland, David

**Publication Date**

2007-12-01



**California Center for Population Research**  
**University of California - Los Angeles**

**Quarter-Squares Revisited: Earlier  
Tables, Division of Labor in Table  
Construction, and Later  
Implementations in Analog Computers**

David D. McFarland

CCPR-074-07

December 2007

*California Center for Population Research  
On-Line Working Paper Series*

---

# Quarter-Squares Revisited: Earlier Tables, Division of Labor in Table Construction, and Later Implementations in Analog Computers

---

David D. McFarland <sup>1</sup>

## Abstract

Quarter-Squares were in use both earlier and more recently than the era from 1876 to 1951 covered in a previous article [22]. These include both earlier printed tables and incorporation into analog computers. Also considered herein are the means by which such tables were constructed, and the social hierarchy developed in conjunction with the division of labor among workers of quite different levels of mathematical expertise.

## Introduction

The Quarter-Square identity replaces multiplication with addition and subtraction:

$$xy = q(x + y) - q(x - y)$$

where  $q$  denotes the Quarter-Square function,  $q(w) = w^2/4$ . The right side of the identity also requires two separate instances of evaluation of the Quarter-Square function.

Printed tables of the Quarter-Square function were thus used as computational aids, much like the better-known printed tables of logarithms. The beginning of such a table is shown here, with integers in the first column (labeled  $w$ ) and their Quarter-Squares, with the decimals omitted, in the third column (labeled  $100q$ ). (Ignore for now the second column.)

$w$	$100d$	$100q$
1	-	25
2	75	100
3	125	225
4	175	400
5	225	625
6	275	900
7	325	1 225
8	375	1 600
9	425	2 025
10	475	2 500
⋮	⋮	⋮

A previous article [22] covered the use of Quarter-Squares in some detail, including printed tables from as early as 1876 and as late as 1951 plus others during that interval [17], [15], [28].

Additional information regarding Quarter-Squares has come to my attention since completion of that arti-

cle. This includes tables even earlier than those reported in the previous article, dating back at least to 1820, and probably to 1817. It also includes use of Quarter-Squares more recently, in the latter half of the 20th century, but in the form of analog computer components rather than printed tables.

## Earlier Quarter-Square Tables

Since completing my earlier article, I have seen two additional early Quarter-Square tables published in 1856 and 1820, and have seen references to several other early tables, the earliest published in 1817.

The 1856 book, consisting entirely of Quarter-Squares of integers as high as 100,000, is by Samuel Linn Laundry [19].

The 1820 table is in an arithmetic book by John Leslie (see Figure 1). This table gives Quarter-Squares of numbers as high as 2,000 [20, pages 245-257].

Leslie in the 1820 edition of his book cites one earlier set of Quarter-Squares, which had been published by Antoine Voisin in 1817 [20, page 257], [32]. Leslie describes the Voisin table as going to 20,000, but himself prints Quarter-Squares only to 2,000.

Laundry cites a number of tables prior to his 1856 publication date. Alas, many of these references are very sketchy, and I have managed to locate only one of the items Laundry cites, namely the aforementioned 1820 edition of the Leslie book. Fortunately that is the earliest and most important one, except for Voisin's.

Laundry also mentions, but neglects to give adequate citations for, publications by Galbraith, Penny Cyclopaedia, and Sylvester, and a manuscript by Shortrede.

Glaisher, in a 1900 encyclopaedia article on 'Mathematical Tables', had a brief section on Quarter-Squares [8, page 8]. There he cited Laundry for the most extensive Quarter-Square table.

Glaisher states that the earliest book on Quarter-Squares was the 1817 volume by Voisin, but does not note predecessors, especially Ludolf [21], whose 1690 table of squares includes a suggestion that those (squares, not Quarter-Squares) may be used to facilitate multiplication.

This literature contains some critiques as well as lists of tables, the tables themselves, and discussion of their properties.

Voisin, in the title of his book, had referred to the numbers therein as 'logarithmes'. On this point Laundry

---

<sup>1</sup>Department of Sociology, University of California, Los Angeles 90095-1551 USA, [www.soc.ucla.edu/faculty/mcfarland](http://www.soc.ucla.edu/faculty/mcfarland), [mcfarland@soc.ucla.edu](mailto:mcfarland@soc.ucla.edu). Support by the Academic Senate Council on Research, University of California, Los Angeles, of my research on early sociological computing is gratefully acknowledged. Also I wish to thank Curtis Jones and Bob Otnes for helpful suggestions, and the latter for lending me his copy of the Laundry tables.

states that the items in that table were not what today are called ‘logarithms’, but rather Quarter-Squares. Leslie [20, page 257] puts it in even stronger terms, writing that Voisin “appears to be a man of some ingenuity, but not to possess correct notions of science” and adding “the numbers which [Voisin’s table] contains have undoubtedly no relation whatever to logarithms”.

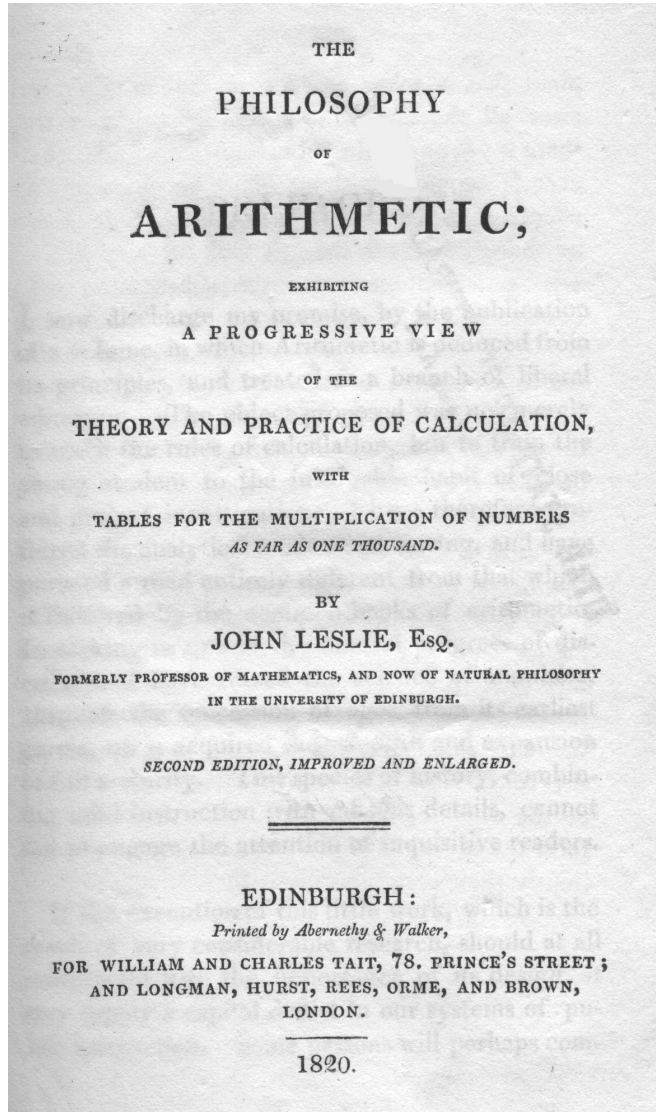

**Figure 1.** Title page from 1820 Leslie book which includes Quarter-Squares

Leslie, who took Voisin to task, was himself taken to task by Laundry (see below, in the section on errors in tables).

Incidentally, Laundry [19, page v] writes that Merpaut [23] also used Quarter-Squares in conjunction with a table of reciprocals to facilitate division, a procedure that I had mentioned as possible but had dismissed as more cumbersome than simply using logarithms.

### Ancient Cuneiform Tables

Neither Galisher nor Ludolf may have been the first to no-

tice that squares, although not as convenient as Quarter-Squares, could also facilitate multiplication. There exist ancient Middle Eastern clay tablets that may have been used in that manner; they gave squares of half-integers rather than Quarter-Squares of integers.

Letting  $q$  and  $s$  denote Quarter-Squares and squares respectively, the corresponding equations are:

$$xy = q(x + y) - q(x - y)$$

$$xy = s\left(\frac{x + y}{2}\right) - s\left(\frac{x - y}{2}\right)$$

Both yield products without requiring multiplication per se, but the squares version requires halving as well as addition and subtraction. This introduces the additional complication that the arguments obtained by halving the sum and difference are not necessarily integers. This creates a possible use for a table of squares of half-integers: 1, 1.5, 2, 2.5, 3, 3.5,...

Now such tables have existed for thousands of years. One such is CBS 1535, in the Catalog of the Babylonian Section, University of Pennsylvania Museum [25, page 34]. This is a clay tablet with numbers represented by wedge-shaped marks. The number system is sexagesimal (base 60), although lacking a zero concept and notation, which introduces some ambiguities.

Parts of this tablet are damaged, but from the preserved parts Neugebauer and Sachs were able to reconstruct and translate it as a table of squares of the half-integers which in our notation would be 1, 1.5, 2, 2.5, ..., 59, 59.5, and 1 of the next higher order.

John Derbyshire writes, of Hammurabi-era Babylonians, that “we know ... that the tables of squares were used to aid multiplication... The Babylonians knew [the squares formula above] – or ‘knew’ it, since they had no way to express abstract formulas in that way. They knew it as a procedure—we would nowadays say an *algorithm*—that could be applied to specific numbers” [4, page 25].

He does not specify just how we ‘know’ that, however. The evidence he cites includes tables of squares of half-integers, but I have found no instructions for their use. An alternative possible use would be to obtain more precise answers to questions regarding areas and side lengths of square fields. These tables would give a length to the nearest half-unit, rather than to the nearest unit.

Nevertheless, their use to facilitate multiplication more generally (and not just for square fields) is clearly plausible, if not something we definitely ‘know’.

### Division of Labor in Table Construction

The Quarter-Squares tables themselves were prepared *not* by squaring each value of the argument and dividing the square by 4, but rather by the method of differences. This procedure had been used by earlier makers of tables, notably Gaspard de Prony (born 1755, died 1839), whose workers typically had no knowledge of mathematics beyond addition and subtraction [1, page 195]. Some of

them were former hairdressers who had fallen on hard times after the French Revolution, when aristocrats were no longer wearing their elaborate wigs (and in some cases no longer wearing their heads) [9].

On the division of labor, economists still refer to Adam Smith, sociologists to Emile Durkheim, and those interested in the history of computing to Charles Babbage. One of Smith's interests in division of labor concerned its increased efficiency in production of material goods, pin manufacture being an example he famously discussed, but his main interest in division of labor concerned its relation to markets, and to money as a medium of exchange [31, pages 4-5, chapters II-IV]. Babbage, while giving more detailed consideration to pin manufacture than Smith had done, devoted an entire chapter to division of *mental* labor. However he was primarily interested in division of labor not *per se*, but as a prerequisite for mechanization [1, pages 176-190, chapter XX].

Durkheim's interest in division of labor emphasized its social concomitants, notably the interdependence of those performing different tasks, and its cultural concomitants, notably the legal system that authorizes contracts, specifies what kinds of contracts are permitted, and enforces them [6]. In these regards my own emphasis is closer to Durkheim's than to either Smith's or Babbage's. Furthermore the result here, if not a legal system, is another cultural product, namely a means of facilitating computations.

Nevertheless I emphasize not just interdependence, but development of social hierarchy as well, with some assigning tasks to others and evaluating their performance.

This is in contrast to Durkheim, who at times writes of division of labor as creating pressure toward equality (e.g., "[T]he contract of society must put all those associated on the same level, their shares must be identical, and their functions the same", or "Society is forced to reduce ... disparity as far as possible by assisting in various ways those who find themselves in a disadvantageous position and by aiding them to overcome it") [6, pages 124, 379]. At that point I am more aligned with Babbage, who explicitly noted the hierarchy accompanying division of labor.

The hierarchy in question is *not* merely a matter of some having more mathematical knowledge than others. It also includes some being in positions of authority over others, assigning tasks to them and evaluating their performance.

The organization established by de Prony had nearly 100 people arrayed in three hierarchical levels, each level in some manner dependent on the other two. The top level consisted of several mathematicians who located various formulae for the function to be tabulated and chose the one best suited for numerical treatment. The middle level consisted of several others who translated the selected formula into numerical procedures, gave them to the third level, and checked the results produced by the latter. The bottom level consisted of approximately

70 people to carry out the computations using only the most widely known of arithmetic operations.

This is a far cry from Napier or Briggs single-handedly producing an entire table. This arrangement of de Prony produced not only a hierarchical organization, but also a prototype for organizations whose output was primarily cultural, rather than physical.

A sociological alternative to a hierarchy of *people* is a hierarchy of *roles*, which allows for the possibility that a person may fill multiple roles or move between roles, or may share a role with others. This permits the same framework to be used for a table prepared by an individual and a table prepared by a team of whatever size.

In production of a Quarter-Square table, the highest level role, which required some knowledge of mathematics, would proceed along the following lines. Taking the derivative of  $q(w) = .25w^2$  yields  $q'(w) = .5w$ . The second derivative is  $q''(w) = .5$ , a constant that does not depend on  $w$ . Thus a table of the Quarter-Square function could be constructed using constant second differences.

Conversion of the calculus into discrete computations on the positive integers would yield iterative expressions for first differences and the function values themselves:

$$d(w + 1) = d(w) + .50$$

$$q(w + 1) = q(w) + d(w + 1)$$

The second, supervisory level role would include getting this into a form without formulae, and instead with easily understood instructions for performing the appropriate additions. Omission of decimal points would further simplify matters. The supervisory role would also involve providing the first few lines of the table, as illustrated above.

Continuation thereof would be the third level role, which could be filled by someone who knows little or no mathematics beyond addition. Instructions for the actual computers (a term which in that era referred to people rather than machines [10]) would be as follows:

1. In the column labeled  $w$ , obtain each entry by adding 1 to the preceding entry.
2. In the column labeled  $100d$ , obtain each entry by adding 50 to the preceding entry.
3. In the column labeled  $100q$ , obtain each entry by adding the  $100d$  value on its line to the preceding  $100q$  value in its column.

This could also be set up for multiple persons simultaneously filling the computational role on different parts of the table. For example, a different worker could fill in Quarter-Squares starting at 101 while the first was working on 1-100, needing only for the supervisor to start up

a second segment of the table as follows (again omitting decimal points):

$w$	$100d$	$100q$
100	-	250 000
101	5 025	255 025
102	5 075	260 100
$\vdots$	$\vdots$	$\vdots$

Description of a table often leaves unspecified who or even how many people served in the different roles. Jones, for example, describes how to use his Quarter-Square table, but not how the table itself was prepared [15, page 11]. Likewise for the Chambers table [27, page xlii].

Laundy is somewhat more forthcoming. Although hardly providing all one might like to know about preparation of his Quarter-Squares book, he does at one point refer to his own contribution as “superintendence” [19, page iii].

### Errors in Tables

The supervisory role also involves evaluation of the results. Checking of the addition could be done, without needing to repeat it all, by a supervisor who *does* know how to multiply and divide and who would periodically multiply a number by itself and divide by 4, preferably selecting values that contain the digit 0 or otherwise simplify that calculation. For example,  $10^2/4$  is easily calculated to be 25 and  $20^2/4$  is easily calculated to be 100, so if those values are correct in the table being produced, that would give some assurance that the intervening values may be correct as well. (This matter will receive further consideration below.)

541	73170	591	87320	641	102720	691	119370	741	137270
542	73441	592	87616	642	103041	692	119716	742	137641
543	73712	593	87912	643	103362	693	120062	743	138012
544	73984	594	88209	644	103684	694	120409	744	138384
545	74256	595	88506	645	104006	695	120756	745	138756
546	74529	596	88804	646	104329	696	121104	746	139129
547	74802	597	89102	647	104652	697	121452	747	139502
548	75076	598	89401	648	104976	698	121801	748	139876
549	75350	599	89700	649	105300	699	122150	749	140250
550	75625	600	90000	650	105625	700	122500	750	140625

**Figure 2.** Excerpt from Leslie 1820 table, including his erroneous value for  $q(747)$

Another method of producing a table, even simpler than the method of differences, is to merely reprint a table already calculated by someone else. Laundy reports on two instances he had discovered: “It is not a little remarkable, that Leslie and Galbraith both repeat an error which occurs in Voisin’s Table, thus showing beyond doubt, that they merely reprinted from Voisin. The error referred to is in the quarter-square of 747, which in all three works appears as 139,052, the correct number being 139,502” [19, page vi]. An excerpt from the Leslie table, including his error, is given in Figure 2. Inciden-

tally, both the Chambers and the Jones tables give the correct value [27, page 440], [15, page 155].

This error in the table, it should be noted, almost certainly occurred in the process of getting the computed results into print, rather than in the computation itself. The latter would require the quite improbable occurrence of two successive errors, one 450 too low, the next 450 too high, exactly cancelling each other and thus getting the series back on track. Much more plausible is the scenario that has a typesetter transposing two adjacent digits in one line, but setting the other lines correctly.

The method outlined above, of checking for computational errors, would not catch such a printing error unless the supervisor doing the checking happened to do so on exactly the erroneous line. Differencing, a more laborious checking process, would have caught it, however [10, page 37].

I have not seen the Galbraith table, but have inspected the Leslie table and its accompanying description. To be fair, one must note that Leslie acknowledged his source, “a small book by Antoine Voisin, printed in 1817 [which] contains a table of quarter-squares for the multiplication of whole numbers from 1 to 20,000 [and is entitled] Tables des Multiplications...”.

Furthermore, Leslie used the term ‘reprinted’ rather than ‘recomputed’, when he wrote, “It would be of great service ... to have the whole table *reprinted*, or perhaps even extended to 200,000” [20, page 257, emphasis added]. Although Leslie does not quite say so, the careful reader might reasonably take his statement as indicating that Leslie’s own contribution was also ‘reprinting’. The table in Leslie’s book would stop at 2,000, however, since that book dealt with the entire field of arithmetic rather than focusing specifically on Quarter-Squares.

One might suspect that authors who preface their tables with lengthy descriptions of their preparation methods (e.g. [19, pages ix - xiii]) do so not only to explain those methods *per se*, but also to assure readers that they have in fact calculated the table entries, and not merely reprinted them from elsewhere. Likewise for authors who point out errors in earlier tables.

### Quarter-Squares in Analog Computers

Users of logarithms had their choice of table lookup and a mechanical counterpart in the form of a slide rule. There was not, to my knowledge, any mechanical counterpart of Quarter-Square tables during the era when such tables were published. There were machines which performed multiplication, to be sure, but those whose mechanical principles I have studied were not based on Quarter-Squares.

Something of that sort, although electronic rather than mechanical, came more recently, in the 1950s through the 1980s, particularly in the development of analog computers. See Figure 3.

In 1953 Edwards presented a “Survey of Analog Multiplication Schemes” [7]. Between 1956 and 1967 there

were several Master's Theses which included designs for Quarter-Square components of analog computers [3], [5], [11], [13], [16], [33].

Already by 1962 there were enough different implementations of Quarter-Squares that Morrill, writing in the Huskey and Korn *Computer Handbook* [14], considered it appropriate to evaluate those alternatives: "While vacuum-tube characteristics, nonlinear resistors ... and special beam tubes ... have all been used to produce the required quadratic functions of the voltages  $X+Y$  and  $X-Y$ , two types of quarter-square multipliers, based on diode function generators ... and triangle integration, are far superior to all others" [24, page 3-42]. Also see [18, page 3-76].

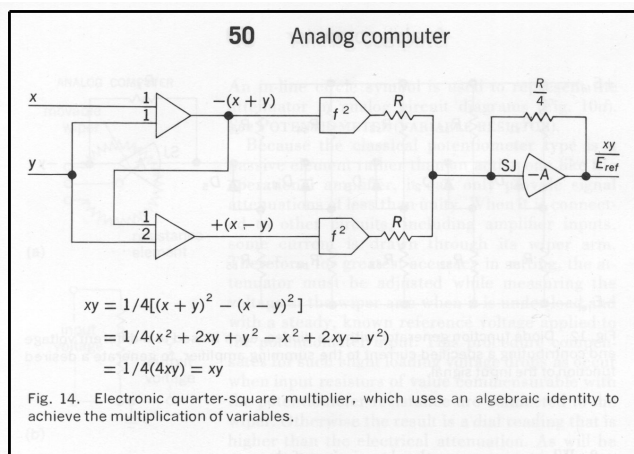

**Figure 3.** Quarter-Squares circuit diagram from 1984 *Encyclopedia of Electronics and Computers* [26, page 50]

While triangle integration, on which Korn himself had written [12], was given equal status in the aforementioned assessment in the Huskey and Korn volume, subsequent computer handbooks paid considerably more attention to the diode function generators [26, pages 48-50], [29, pages 71-74].

Since these analog computer versions of Quarter-Squares involve continuous variables such as voltages, they *could* be used for division, unlike the Quarter-Square *tables*, which offered only discrete (integer) values as arguments. Regarding this point contrast McFarland [22] on tables with Korn [18, page 3-76] on analog computers.

### Conclusion

Quarter-Square tables were published at least as early as 1820, and probably as early as 1817, although it was decades before they entered into common use. The period of common use was described in my previous article [22].

Quarter-Square *tables* may have disappeared around the 1950s, but the Quarter-Square function itself continued on, albeit concealed from the view of ordinary users, inside the 'black box' that was an analog computer.

Whether Quarter-Square tables still exist hidden inside the microchips of present-day digital computers I do not know, but I suspect not. I am unable to assess whether Quarter-Squares might be faster or otherwise preferable to logarithms for multiplication. However, they would be redundant in chips which already contain logarithms for purposes other than multiplication.

Richards, in his *Arithmetic Operations in Digital Computers* [30, Chapter 9], has a 38 page chapter devoted to Decimal Multiplication and Division. There he discusses several different schemes for multiplication, but Quarter-Squares is not among them.

Finally, the phenomenon that Babbage referred to as the division of *mental* labor has not only survived to the present, but also has greatly expanded with both machines and organizations increasingly joining individual people in producing books and other cultural products.

## References

- [1] Babbage, Charles 1832. *On the Economy of Manufactures*. Fourth edition enlarged, 1835. Reprinted 1971. New York: Augustus M. Kelley Publishers.
- [2] Chambers. See Pryde.
- [3] Court, Joel Dennis 1966. *The quarter square multiplier using M.O.S. transistors*. M.S. thesis in Electrical Engineering, University of Pennsylvania. (Item not seen; listed in WorldCat.)
- [4] Derbyshire, John 2006. *Unknown Quantity: A Real and Imaginary History of Algebra*. Washington, DC: Joseph Henry Press.
- [5] Dolotta, T. A. 1957. *A four-quadrant quarter-square diode multiplier*. M.S.E. thesis, Princeton University. (Item not seen; listed in WorldCat.)
- [6] Durkheim, Emile 1893. *De la Division du Travail Social*. Translated 1933 by George Simpson as *Division of Labor in Society*. New York: Macmillan.
- [7] Edwards, C. M. 1953. "Survey of Analog Multiplication Schemes." Presented at ACM meeting, September 1953. (Item not seen; cited by Korn [18].)
- [8] Glaisher, James W. L. 1900. "Tables, Mathematical." Pages 7-15 in volume 23 of *Encyclopaedia Britannica*. New York: The Werner Company.
- [9] Grattan-Guinness, I. 1990. "Work for the Hairdressers: The Production of de Prony's Logarithmic and Trigonometric Tables." *Annals of the History of Computing* 12 (No. 3, Summer): 177-185.
- [10] Grier, David Alan 2005. *When Computers Were Human*. Princeton: Princeton University Press.
- [11] Harnett, Robert Thomas 1959. *A quarter-square electronic multiplier*. M.S. thesis, Ohio State University. (Item not seen; listed in WorldCat.)
- [12] Hartmann, J., G. A. Korn, and R. L. Maybach 1960. "Triangle-integration Multipliers." Department of Electrical Engineering, University of Arizona. *ACL Mem.* 18. (Item not seen; cited by Morrill in Huskey and Korn, page 3-62.)

- [13] Haspert, Julian Kent 1967. *A flueric quarter square multiplier*. M.S. thesis, University of Maryland. (Item not seen; listed in WorldCat.)
- [14] Huskey, Harry D., and Granino A. Korn, eds. 1962. *Computer Handbook*. New York: McGraw-Hill.
- [15] Jones, George William 1894. *Logarithmic Tables*. Fifth edition. London: Macmillan, and Ithaca, N.Y.: George W. Jones.
- [16] Kay, Robert M. 1962. *Quarter square analog multiplier*. M.S. thesis, University of Wisconsin-Madison. (Item not seen; listed in WorldCat.)
- [17] Kent, William St George 1876. *Some Properties and Tables of the One Quarter Squares of Numbers...* Phillipsburg, New Jersey: No publisher indicated. (Item not seen; listed on WorldCat.)
- [18] Korn, Granino A. 1962. "Electronic Function Generators, Switching Circuits, and Random Noise Generators." Pages 3-62 to 3-84 in Huskey and Korn [14].
- [19] Laundry, Samuel Linn 1856. *Table of Quarter Squares of all Integer Numbers up to 100,000, by which the Product of two Factors may be found by the aid of Addition and Subtraction Alone*. London: Charles and Edwin Layton. Reprinted 2005 by UMI Books on Demand. Distributed by New York: AstroLogos Books.
- [20] Leslie, John 1820 *Philosophy of Arithmetic*. Second edition. Edinburgh: William and Charles Tait; London: Longman, Hurst, Rees, Orme, and Brown.
- [21] Ludolf, Johann Hiob 1690. *Tetragonometria Tabularia*. Lipsiae: Apud L.S. Coernerum; Amstelodami: Apud Jansonio-Waesbergios. (Item not seen; cited by Glaisher, page 8; listed in WorldCat.)
- [22] McFarland, David D. 2007. "Tables of Quarter-Squares, Sociologic[al] Applications, and Contributions of George W. Jones." *Journal of the Oughtred Society* 16: No. 1, 19-26.
- [23] Merpaut, J. M. 1832. *Tables Arithmonomiques*. Vannes: (publisher not indicated). (Item not seen; cited by Laundry, page v; Glaisher, page 8; listed in WorldCat.)
- [24] Morrill, Charles D. 1962. "Electronic Multipliers and Related Topics." Pages 3-40 to 3-62 in Huskey and Korn [14, page 3-76].
- [25] Neugebauer, Otto, and A. Sachs 1945. *Mathematical Cuneiform Texts*. New Haven: American Oriental Society.
- [26] Parker, Sybil P., ed. 1984. "Multipliers." Pages 48-49 in: *McGraw-Hill Encyclopedia of Electronics and Computers*. New York: McGraw-Hill.
- [27] Pryde, James, ed. 1883. *Mathematical Tables*. New Edition. Edinburgh and London: W. & R. Chambers, Ltd.
- [28] Pryde, James, ed. 1930. *Chambers's Seven-Figure Mathematical Tables*. New edition, with a greatly extended 'Explanation of the Tables' by Walter F. Robinson. Edited by Archibald Milne. Reprinted 1951. Edinburgh and London: W. & R. Chambers, Ltd.
- [29] Ralston, Anthony, ed. 1976. "Multiplication and Division of Variables." Pages 71-80 of *Encyclopedia of Computer Science*. New York: Van Nostrand Reinhold.
- [30] Richards, R. K. 1955. *Arithmetic Operations in Digital Computers*. Princeton: Van Nostrand.
- [31] Smith, Adam 1776. *An Inquiry Into the Nature and Causes of the Wealth of Nations*. London: W. Strahan and T. Cadell. Modern Library edition, New York: Random House, 1937.
- [32] Voisin, Antoine 1817. *Tables de Multiplications ou Logarithmes des Nombres Entiers depuis 1 jusque'a 20,000*. (Item not seen; cited by Leslie [20, page ]; Glaisher [8]; and Laundry [19, page iii].)
- [33] Whigham, Robert Herschel 1965. *A fast quarter-square multiplier*. M.S. thesis, University of Arizona. (Item not seen; listed in WorldCat.)