

UNIVERSITY OF CALIFORNIA  
SANTA CRUZ

**ON THE DRIVING FORCE FOR SYNTACTIC MOVEMENT**

A dissertation submitted in partial satisfaction of the  
requirements for the degree of

in

LINGUISTICS

by

**Erik Zyman**

June 2018

The Dissertation of Erik Zyman  
is approved:

---

Professor James McCloskey, Chair

---

Professor Sandra Chung

---

Professor Jorge Hankamer

---

Tyrus Miller  
Vice Provost and Dean of Graduate Studies

Copyright © by

Erik Zyman

2018

# Table of Contents

<b>Abstract</b>	vi
<b>Acknowledgments</b>	viii
<b>1 Introduction</b>	1
<b>2 Janitzio P’urhepecha clause structure</b>	8
2.1 Introduction . . . . .	8
2.2 Using adverbials as syntactic landmarks . . . . .	11
2.3 Verb positions . . . . .	15
2.4 Polarity particles . . . . .	19
<b>3 Profligate subject movement</b>	25
3.1 Identifying the subject positions . . . . .	25
3.1.1 [Spec,VoiceP] . . . . .	25
3.1.2 [Spec,AspP] . . . . .	26
3.1.3 [Spec,TP] . . . . .	26
3.1.4 [Spec,MoodP] . . . . .	27
3.1.5 [Spec,PolP] . . . . .	27
3.1.6 Summary . . . . .	28
3.2 What drives profligate subject movement? . . . . .	30
3.2.1 Hypothesis A: Profligate subject movement is <i>altruistic</i> . . . . .	31
3.2.2 Hypothesis B: Profligate subject movement is <i>greedy</i> . . . . .	39
3.2.3 Hypothesis C: Profligate subject movement is <i>Labeling-driven</i> . . . . .	46
<b>4 Subjecthood and quantifier float</b>	52
4.1 Introduction . . . . .	52
4.2 Where quantifiers can and can’t float . . . . .	55
4.2.1 Subjects . . . . .	55
4.2.2 Nonsubjects . . . . .	59
4.2.3 Interim summary . . . . .	65
4.3 Stranding vs. adjunction I: Testing the distributional predictions . . . . .	66

4.3.1	Quantifier float in subject positions	67
4.3.2	Quantifier float in nonsubject positions	70
4.3.3	Non-DP positions	73
4.3.4	Interim summary	75
4.4	Stranding vs. adjunction II: Testing the case-matching predictions	80
4.5	Stranding vs. adjunction III: Testing the island-sensitivity predictions	86
4.6	Conclusion	92
<b>5</b>	<b>Hyperraising to object</b>	<b>95</b>
5.1	The phenomenon: “accusative + complementizer” (Acc-C)	97
5.2	The position question: Is DP <sub>ACC</sub> in the matrix or in the embedded clause?	99
5.2.1	Ordering with respect to matrix adverbials	100
5.2.2	Condition B	101
5.3	The derivation question: Does DP <sub>ACC</sub> end up in the matrix by movement or base-generation?	104
5.3.1	Intervention effects	104
5.3.2	Interaction with islands	108
5.3.3	Escape-hatch blocking	111
5.4	Could ACC-C be finite object control?	114
5.4.1	DP <sub>ACC</sub> is not an argument of the matrix V	116
5.4.2	A negative DP <sub>ACC</sub> can reconstruct into the embedded clause for scope	118
5.4.3	<i>Eska</i> -rationale clauses are relatively porous	122
5.4.4	Interim conclusion	124
5.5	Analysis	124
5.5.1	Not only Voice and V, but also <i>v</i>	125
5.5.2	Hyperraising to object targets [Spec, <i>v</i> P]	128
5.5.3	Putting it all together (with a derivation)	131
5.6	Against Greed- and Labeling-based alternatives	137
5.6.1	Alternative A: Case-driven greedy movement	138
5.6.2	Alternative B: Non-Case-driven greedy movement	140
5.6.3	Alternative C: Labeling-driven movement	142
5.7	Conclusion	143
<b>6</b>	<b>Conclusion</b>	<b>145</b>
<b>A</b>	<b>How high can the verb raise in Janitzio P’urhepecha?</b>	<b>149</b>
<b>B</b>	<b>Which quantifiers float in Janitzio P’urhepecha?</b>	<b>156</b>
<b>C</b>	<b>More on quantifier float in ditransitive clauses</b>	<b>158</b>

<b>D Evaluating two alternative analyses of the Subject Condition effects</b>	<b>161</b>
D.1 Bošković 2018a . . . . .	161
D.2 Ott 2015 . . . . .	164

## Abstract

On the Driving Force for Syntactic Movement

by

Erik Zyman

This dissertation aims to push forward our understanding of syntactic displacement, a phenomenon—analyzed here as movement, or Internal Merge ([Chomsky 2004](#))—in which an element occurs in one position in surface syntax but occupies some other position covertly. One open question about movement is what its “driving force” is. Three prominent hypotheses are **Greed** (a constituent moves to satisfy a feature of its own—[Bošković 2007, a.o.](#)), **Enlightened Self-Interest** (a constituent moves to satisfy a feature of its own *or* of the head to whose specifier it moves—[Lasnik 1995, a.o.](#)), and **Labeling** (a constituent moves so that every relevant constituent can be labeled—[Chomsky 2013, a.o.](#)).

This dissertation argues for option two, Enlightened Self-Interest, on the basis of P’urhepecha data elicited from native speakers. P’urhepecha is an isolate of Michoacán State, Mexico; the variety investigated here is Janitzio P’urhepecha (JP). Following an investigation (Chapter 2) of JP finite-clause syntax, Chapter 3 argues that JP allows the subject to move to any of a wide array of specifier positions in the inflectional layer (“profligate subject movement”), and that this movement is driven by features of clausal functional heads, not by a feature of the subject itself or by the Labeling Algorithm (LA). Chapter 4 investigates JP quantifier float, which further supports

the results of Chapter 3 and provides evidence that (JP) floated quantifiers are stranded adnominal elements, not adverbials. Chapter 5 argues that JP allows hyperraising to object (subject-to-object raising from finite clauses), and that this involves two steps of purely altruistic (higher-head-driven) movement, rather than being driven by properties of the moving element or by the LA.

Both profligate subject movement and hyperraising to object in JP, then, are driven by features of c-commanding heads, supporting Enlightened Self-Interest over Greed and Labeling. Furthermore, JP hyperraising to object provides evidence that the  $A/\bar{A}$ -distinction does not emerge from two classes of syntactic positions, but is instead a consequence of features on particular functional heads. Finally, if indeed Internal Merge is feature-driven in the way argued for here, then we expect External Merge to be also—contra the Free Merge hypothesis.

## Acknowledgments

Very many thanks indeed to the following people:

First and foremost, the native speakers of P'urhepecha who generously, and with great hospitality, shared with me their knowledge of, insights into, and reflections on their language: Antonio Reyes Justo, María Bárbara Bartolo López, Edith Araceli Campos de la Cruz, Elvia Campos Talavera, Araceli de la Cruz Guzmán, Gloria de la Cruz Guzmán, Roque Eligio Hernández, Delfina Florentino López, Juan Gabriel Florentino, Elizabeth Guzmán Bartolo, Marimar Guzmán López, Esvelia Guzmán Reyes, María Estela Guzmán Reyes, Olivia Guzmán Reyes, María Isabel Hernández Tovar, Blanca Estela López Campos, and María de la Luz Séptimo Gabriel (Janitzio P'urhepecha), Javier Mellápeti Cuiriz (Santa Fe de la Laguna P'urhepecha), and many speakers of other varieties—varieties that are beyond the scope of this dissertation. I owe Antonio Reyes Justo in particular a tremendous debt of gratitude not only for all the knowledge of his language that he has generously shared with me but also for introducing me to many other native speakers of P'urhepecha, for helping to organize the elicitation-and-discussion sessions, and for his valuable assistance with many other practical matters.

The members of my dissertation committee—Jim McCloskey, Sandy Chung, and Jorge Hankamer—for extremely valuable discussion, feedback, and guidance at every stage of this work. More specifically:

Jim, my advisor, for countless engaging conversations about matters both syn-



tactic and non- — as well as many excellent seminars and proseminars — that have played an indispensable role in pushing this work forward, and have shaped me and my fellow graduate students into keener syntacticians and linguists more generally, on account of his characteristic combination of theoretical insight, empirical perceptiveness, open-minded inquisitiveness, and unfailing good cheer and sense of humor.

Sandy, for her matchless ability to ask subtle, non-obvious questions about the empirical landscape, tease out predictions of analyses, and identify unsolved problems with the theory, thereby pushing forward our empirical and theoretical understanding in a dramatic way. (And for presenting me with the most formidable challenge I've faced as a syntactician so far, which was thrilling but surreal: a series of extremely difficult, ambitious, wide-ranging questions she asked me about the mysterious A/ $\bar{A}$ -distinction during my qualifying exam defense, which culminated with: "Have you destroyed syntax?")

Jorge, for ceaselessly questioning the conventional wisdom, and the analyses and theoretical assumptions that happen to be popular at any given time; for the excellent courses I took with him (Syntax A and two morphology seminars); and for two highly productive independent studies (one on the driving force for movement and one on subjecthood), which I learned a great deal from and really enjoyed, even if he did occasionally say to me things like, "I'm not sure I can ever forgive you for making me read that."

The other members of the UCSC Linguistics faculty, who I've learned an enormous amount from, and my friends and fellow graduate students in the department:

Nick Kalivoda, Andrew Hedding, Lisa Hofmann, Jason Ostrove, Deniz Rudin, Karen Duek, Brianna Kaufman, and many others.

The linguists who taught and advised me when I was an undergraduate at Princeton: Edwin Williams, Bob Freidin, Joshua Katz, Christiane Fellbaum, Leonard Babby, Adele Goldberg, and Volya Kapatsinski, all of whom I learned a great deal from indeed.

Various colleagues, for valuable discussion of this work: Judith Aissen, Pranav Anand, Beatriz Arias Álvarez, Nate Arnett, Nico Baier, Chris Collins, James Collins, Amy Rose Deal, Nathaniel Deutsch, John Gluckman, Grant Goodall, Jane Grimshaw, Heidi Harley, Peter Jenks, Kyle Johnson, Nick Kalivoda, Itamar Kastner, Stefan Keine, Julie Anne Legate, Tyler Lemon, Travis Major, Ben Mericli, Jason Ostrove, Patricia Schneider-Zioga, Michelle Sheehan, Clara Sherley-Appel, Ivy Sichel, Adam Singerman, Maziar Toosarvandani, Susi Wurmbrand; the participants in Pre-290 (UCSC, Fall 2014), the Winter 2015 Research Seminar at UCSC, especially Junko Ito, and the Fall 2015 Morphology seminar at UCSC; attendees at Linguistics at Santa Cruz (LASC) 2015 (March 2015), the Berkeley Syntax and Semantics Circle (April 2015), the 11<sup>th</sup> Annual Graduate Research Symposium at UCSC (April 2015), LSA 2016 (Washington D.C., January 2016), NonFinite Subjects (University of Nantes, April 2016), the 12<sup>th</sup> Annual Graduate Research Symposium at UCSC (April 2016), the Workshop on the Languages of Meso-America (UCSC, December 2016), LSA 2017 (Austin, January 2017), and talks at the University of Florida (February 2017) and the University of Chicago (April 2018); and three anonymous *Natural Language and Linguistic Theory* reviewers and Associate

Editor Ad Neeleman. The usual disclaimers apply.

My other friends, both in California (Jesse Zymet, Greg Kufera, Zach Lebowski, Jen Black, Anna Tchetchetkine, and Max McGowen, among others) and elsewhere (too many to name here).

My comrades in UC Student Workers UAW 2865 Santa Cruz, for their tireless efforts on behalf of our rights as workers, and related causes.

My family—and most especially my parents, Nancy Carrasco and Samuel Zyman—for everything.

This material is based upon work supported by the National Science Foundation Graduate Research Fellowship Program under Grant No. DGE-1339067. Any opinions, findings, and conclusions or recommendations expressed in this material are those of the author and do not necessarily reflect the views of the National Science Foundation. This research was also supported by two Summer Research Fellowships (2014, 2015) from the Institute for Humanities Research at UCSC.

# Chapter 1

## Introduction

A crucial and fundamental task for syntactic theory is to answer the following questions:

- (1) a. What syntactic operations are made available by the human capacity for language?
- b. What are their properties?
- c. Why do they have the properties they do?

This dissertation will contribute to achieving this goal by pushing forward our understanding of *displacement*, a phenomenon which is pervasive in the syntax of natural languages and which is therefore of central importance to syntactic theory. Displacement is a phenomenon in which an element X occurs in one position in surface syntax (call it position Z for convenience) but shows evidence of occupying some other position (call it position Y) in some representation distinct from the one that determines pronunciation:

- (2)  $X_Z \dots X_Y$

On one influential approach to displacement, which has been dominant throughout the history of generative grammar, this is the result of *movement*. On this approach, X is

in position Y underlyingly (or, in derivational terms, at a derivational stage that does not directly feed pronunciation), but moves to position Z, producing the surface form which is actually observed:

$$(3) \quad \overset{\text{X}_Z \dots \text{X}_Y}{\curvearrowright}$$

For most of the history of generative grammar, displacement seemed like an anomaly: it was unclear why it should exist. But a major step toward answering this question was taken when [Chomsky \(2004\)](#) proposed that movement is in fact a subcase of the basic structure-building operation Merge:

$$(4) \quad \text{Merge}(X, Y) \rightarrow \{X, Y\} \quad (\text{cf. Collins 2017})$$

As shown in [\(4\)](#), Merge takes two syntactic objects X and Y (which can be either lexical items or complex syntactic objects previously constructed by Merge) and combines them into a set {X, Y}. (Whether Merge is in fact more complex than this, incorporating additional suboperations such as labeling/projection, is an important question, but not immediately relevant here. See [Merchant 2018:2](#) for a different definition of Merge formulated to account for facts about selection.) Chomsky argues that Merge has two subcases: External Merge and Internal Merge (cf. [Collins & Stabler 2016:48](#), [Freidin 2016:702](#), [Collins 2017:48](#), [Collins & Groat 2018:1](#); see also [Graf 2018](#)). When neither X nor Y in [\(4\)](#) contains/dominates the other, Merge(X,Y) is an instance of External Merge. When X does contain/dominate Y, however, Merge(X,Y) is an instance of Internal Merge. Both subcases of Merge are exemplified below.

$$(5) \quad \textit{External Merge} \text{ (X does not contain/dominate Y)}$$

$$\text{Merge}(\textit{see}, \textit{her}) = \{\textit{see}, \textit{her}\}$$

$$(6) \quad \textit{Internal Merge} \text{ (X does contain/dominate Y)}$$

$$\text{Merge}(\textit{I won't see her}, \textit{her}) = \{\textit{her}, \textit{I won't see her}\}$$

(The example of Internal Merge in (6) abstracts away from the clause-internal phase, if there is one, for ease of exposition. On the related issue of how to distinguish copies from repetitions in a Merge-based system, see Chomsky 2013:40-41, 2015, Freidin 2016:702-705, and Collins and Groat 2018.) The result of the Internal Merge operation in (6) will surface as the topicalization sentence *Her, I won't see*, given a suitable externalization algorithm for ensuring that non-highest copies are (normally) not realized overtly.

As Chomsky pointed out, if movement is simply Internal Merge—a subcase of the independently motivated structure-building operation Merge—then it is in fact not a theoretical anomaly after all. Indeed, it would be anomalous if it did not exist, since blocking it would require a stipulation (namely, that two syntactic objects X and Y could only be merged if neither contained/dominated the other).

This is real progress. But questions remain about this particular structure-building operation (“Internal Merge”):

- (7) a. Precisely how should it be characterized/formulated?
- b. How does it function in the computational process (i.e., in syntactic derivations)?
- c. What constraints is it subject to?

In this connection, it is worth noting that a great deal of research has converged on the conclusion that derivations are (at least largely) driven by properties (“features”) of particular lexical items (heads)—selectional features,  $\phi$ -features, Case features, etc.—and the interactions they enter into. If this is on the right track, then we can ask:

- (8) What are the lexical items and features that drive this *particular* operation (Internal Merge) in the course of a derivation?

Or, for short:

- (9) What is the driving force for movement?

Three prominent hypotheses about this matter that have been developed and defended are the following:

- (10) a. **Greed:** A constituent moves to satisfy a feature of its own.  
(Chomsky 1995a:201; Bošković 1995, 2002, 2007, 2011, 2018b; Grohmann, Drury, & Castillo 2000; Harwood 2015:528, fn. 8; Holmberg, Sheehan, & van der Wal 2016:11, a.o.; see also Goto 2017a)
- b. **Enlightened Self-Interest:** A constituent moves to satisfy a feature of its own (*greedy* movement) or a feature of the head to whose specifier it moves (*altruistic* movement).  
(Chomsky 1995a:297, 2000, 2001, 2004, 2008, Lasnik 1995, 2003, McCloskey 2001, Bošković 2004 [appendix], Cable 2012, Ostrove 2016a, 2017b, Werthen 2018, a.o.; see also Nunes 2016)
- c. **Labeling:** A constituent moves so that every relevant constituent in the structure can receive a label from the syntactic Labeling Algorithm.  
(Chomsky 2013, 2015, 2016, Ott 2015, Rizzi 2015, Smith 2015, Bošković 2018a, a.o.)

As the references above make clear, each of these three hypotheses has had, and still has, numerous defenders. The question, then, of what the driving force for movement is remains highly controversial—there is nothing even approaching a consensus on the matter—despite extensive research into the issue spanning many decades.

This dissertation aims to make progress in resolving these important questions by investigating two varieties of movement in P’urhepecha that are relatively unusual from the perspective of the best-studied languages.

P’urhepecha is an isolate, an indigenous language of Mexico spoken in the

central-western state of Michoacán, in nearby states, and by P'urhepecha immigrants in the U.S. [Vázquez Rojas Maldonado \(2013:8-9\)](#) reports that, according to the 2010 National Population and Housing Survey (*Censo Nacional de Población y Vivienda*) administered by Mexico's National Institute of Statistics and Geography (*Instituto Nacional de Estadística y Geografía*) (INEGI 2010), there are in Mexico 124,494 P'urhepecha speakers age 5 or older, of whom 112,131 also speak Spanish. The National Indigenous Languages Institute (*Instituto Nacional de Lenguas Indígenas*, INALI) reports that there are 128,344 P'urhepecha speakers age 3 or older ([Vázquez Rojas Maldonado 2013:8-9](#); see [Vázquez Rojas Maldonado 2013](#) for more information).

Grammatically, P'urhepecha is an exclusively suffixing, agglutinating, head- and dependent-marking language with a reasonably rich morphological case system, a small amount of verbal agreement (discussed in Chapter 2), pro-drop (in fact, argument drop), and relatively flexible constituent order ([Foster 1969](#), [Friedrich 1970](#), [Wares 1974](#), [Capistrán 2002](#), [Medina Pérez 2006](#), [Villavicencio Zarza 2006](#), [Chamoreau 2007](#), [Mendoza 2007](#), [Vázquez-Rojas Maldonado 2011, 2012](#), [Capistrán Garza 2015](#), a.o.). The variety investigated here is that spoken on the island of Janitzio on Lake Pátzcuaro in Michoacán, henceforth *Janitzio P'urhepecha*.

[Capistrán \(2002\)](#) shows that, in Lake Pátzcuaro P'urhepecha, of which Janitzio P'urhepecha is a subvariety, all six orders of S, V, and O are possible, though constituent-order permutation often has information-structural correlates. In Janitzio P'urhepecha, the basic constituent order is SVO. SVO is the constituent order that is typically provided by my consultants when they are asked to translate sentences from Spanish<sup>1</sup> and it is also, in my experience, the constituent order that is by far the most frequent (in clauses with an overt S and O) in spontaneous speech. Most types of phrases exhibit head-complement order in Janitzio P'urhepecha, although the basic

---

<sup>1</sup>Which could in principle be a translation effect and hence not decisive evidence that Janitzio P'urhepecha is SVO by default.



native adpositions (*jingoni* ‘with’, *anapu* ‘from’, *jimbo* ‘in, at, by’) are postpositions, and auxiliaries (which will play almost no role in this dissertation) follow the verbal projections they take as their complements. These grammatical characteristics of Janitzio P’urhepecha will, of course—along with many others—be prominently on display throughout the examples in this dissertation.

The dissertation is organized as follows. **Chapter 2** establishes in some detail how the clause structure of Janitzio P’urhepecha is organized, focusing on finite clauses. A fine-grained understanding of the structure of such clauses will be crucial to the investigations that follow. **Chapter 3** argues that Janitzio P’urhepecha allows *profligate subject movement* (i.e., movement of the subject to any of a range of specifier positions in the inflectional layer of the clause; cf. Rizzi 1997:281, and see Cable 2012 on a similar phenomenon in Dholuo), and further argues that this movement is *altruistic*: it is driven by features of clausal functional heads rather than by a feature of the moving subject itself or by the Labeling Algorithm. These results in turn lay the foundation for **Chapter 4**, an investigation of quantifier float in the language, which yields further support for the conclusions reached in Chapter 3 and provides strong evidence that floated quantifiers, at least in this language, are stranded adnominal elements rather than adverbials adjoined to some clausal projection. **Chapter 5** argues that Janitzio P’urhepecha allows *hyperraising to object* (raising of the subject of an embedded finite clause to become an object of the matrix clause) and contends that this phenomenon involves two steps of purely altruistic (target-driven) movement, and that alternative analyses on which the movements are driven by features of the moving element itself or by the Labeling Algorithm face serious problems. Both profligate subject movement and hyperraising to object, then, are altruistic (driven by features of c-commanding heads), supporting the *Enlightened Self-Interest* hypothesis about the driving force for movement over the *Greed* and *Labeling* hypotheses. Almost as importantly, the facts of hyperraising to object also narrow down the space of possibilities for understanding the

A/ $\bar{A}$ -distinction, one of the fundamental puzzles in syntax. The phenomenon suggests that the traditional view that particular positions (e.g., [Spec,CP]) are inherently A- or  $\bar{A}$ -positions is untenable, but an approach on which A/ $\bar{A}$ -effects are consequences of *features* on particular functional heads (van Urk 2015, Fong 2017a,b, 2018) is much more promising. **Chapter 6** reviews the results established in the previous chapters and considers some yet larger questions about syntactic structure-building that emerge naturally from the investigations carried out in those chapters.

## Chapter 2

# Janitzio P’urhepecha clause structure

If we are to determine what the “unusual” types of movement found in Janitzio P’urhepecha reveal about the nature of movement and, in particular, about its driving force, it will be essential for us to have a reasonably clear and accurate picture of the clause structure of this language. It is to this preliminary investigation that we now turn.

### 2.1 Introduction

In beginning to ascertain the clause structure of Janitzio P’urhepecha, it will be useful to examine the morphology of the finite verb.

The finite verb consists of a root followed by typically optional derivational suffixes and obligatory voice, aspect, tense, and mood suffixes, in that order (the mood suffix being a portmanteau that also expones the person of the subject). This “template” is schematized below.

(11) *Morphological structure of the Janitzio P’urhepecha finite verb*

$\sqrt{\text{ROOT}}$	(Derivational Suffixes)	Voice	Aspect	Tense	Mood+Person
----------------------	-------------------------	-------	--------	-------	-------------

By the general logic of the Mirror Principle (Baker 1985:375, (4)), this provides

evidence for (at least) the following clause structure for Janitzio P’urhepecha:

(12) *Janitzio P’urhepecha clause structure (to be revised)*

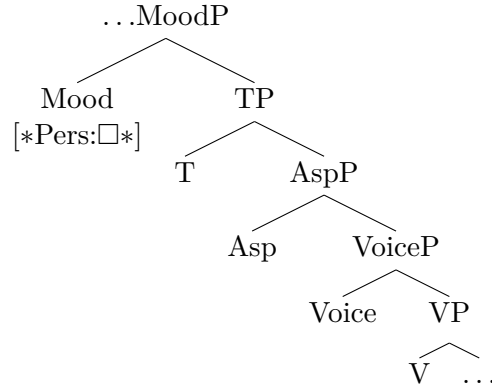

Following Heck and Müller 2007, probe features (features that trigger a probing operation) are notated here with stars—[\*F\*]—and unvalued features with a box: [F:□]. Features with both characteristics—i.e., unvalued features that trigger probing, which if successful will supply them with a value—are notated with stars and a box: [\*F:□\*]. Departing from Heck and Müller’s notation, features that trigger probing and bear an EPP subfeature are notated [\*F\*]<sup>EPP</sup> or [\*F:□\*]<sup>EPP</sup> (depending on whether they *do not* or *do* additionally start out unvalued, and therefore need to be supplied with a value). (All the features discussed in this dissertation are syntactic features—i.e., properties of lexical items [cf. Chomsky 2008, Collins & Stabler 2016:44-45, Collins 2017] that are visible to the syntax and can therefore, at least in principle, enter into syntactic relations. An EPP subfeature is a diacritic on a probe feature of a head H that—after the relevant probing operation finds a goal [and, if applicable, all relevant feature valuation takes place]—forces the goal to internally merge with the highest available projection of H.)

All of this will be illustrated in detail in Chapter 3. It will, however, be worthwhile to clarify this feature system to some extent now by briefly considering some concrete examples. Present T in English (simplifying somewhat, perhaps) could be

analyzed as bearing two unvalued probe features [ $*\text{Pers}:\square^*$ ]<sup>EPP</sup> and [ $*\text{Num}:\square^*$ ] (though it is not clear which of these features bears the EPP subfeature). If so, this T probes (hence the stars); once it finds a suitable goal, the goal supplies the features on T with values (hence the boxes); and then the EPP subfeature forces the goal to internally merge with the highest available projection of T. In Italian and Spanish, by contrast, no feature of finite T obligatorily bears an EPP subfeature, so the DP that values the features of T is not forced to move to [Spec,TP]. The features just considered are unvalued features that are also probe features; by contrast, a DP’s Case feature ( [Case: $\square$ ] ) is an unvalued feature (hence the box) that is typically thought not to be a probe feature (hence the absence of stars—though some analyses will be discussed in later chapters on which this assumption is rejected). Finally, the notion of a probe feature that is not an unvalued feature ( [ $*F^*$ ] ) will be useful for analyzing cases in which there is evidence that probing occurs, but there is no evidence for valuation or agreement of any sort; for example, subject movement in Mandarin and Japanese may be driven by [ $*D^*$ ]<sup>EPP</sup> (or perhaps [ $*N^*$ ]<sup>EPP</sup>) on a clausal functional head.

On the decomposition of the verb phrase, see [Johnson 1991](#), [Larson 1988, 1990, 2017](#), [Bowers 1993, 2002](#), [Kratzer 1996](#), [Diesing 1998](#), [Phillips 2003](#), [Takano 2003](#), [Miyagawa and Tsujioka 2004](#), [Harley 2008](#), [Janke and Neeleman 2012](#), [Gribanova 2013](#), [Marantz 2013](#), [Tucker 2013](#), [Legate 2014](#), [Bruening 2015](#), [Krejci and Tallman 2015](#), and [McCloskey 2017, a.m.o.](#) The lower “VP-shell” will be referred to here as VP and the higher one as VoiceP. (There is no overt voice suffix in the active voice.) There is some additional (nonmorphological) evidence for such a bipartite structure in Janitzio P’urhepecha specifically. In this language, the verb in a ditransitive verb phrase normally precedes both the direct and the indirect object, which can occur in either order. But the linearly earlier object seems to c-command the linearly later one, judging by the Barss-Lasnik tests ([Barss & Lasnik 1986](#)) that can be run, namely variable binding and *mandani ... materu* ( $\approx$  *each ... the other*). See [Jackendoff 1990](#) and [Bruening](#)

2014, however, for analyses of verb phrase structure on which Barss-Lasnik effects do not diagnose c-command.

## 2.2 Using adverbials as syntactic landmarks

Because the five heads shown in (12) are packaged into a single morphological word in the course of the derivation, they cannot directly be used as landmarks by which to determine the position of other elements. But if adverbials could be found that were specialized to adjoin to particular projections in (12) (e.g., VoiceP), these adverbials could be so used (cf. Pollock 1989; see also Postal 1974, Johnson 1991, Bowers 1993, Goodall 1993, Bobaljik & Jonas 1996, Alexiadou & Anagnostopoulou 1998, Cinque 1999, Kiss 2002, Tanaka 2002, Bošković 2004, Cardinaletti 2004, Devine & Stephens 2006, Kirk 2012, Gribanova 2013, Halpert & Zeller 2015, Kalivoda 2015, Ostrove 2015, 2016, 2017a,b, submitted, Ben-Meir 2016, McGarry 2016, Newman 2016, Deal 2017, Desai 2017a, Fong 2017a,b, 2018, Vincent 2017, Danckaert to appear, a.m.o.).

To find such adverbials, let us use as our guide the Cinque hierarchy (Cinque 1999, Tescari Neto 2013:30). According to cartographic analyses such as those of Cinque (1999) and Tescari Neto (2013), clause structure is highly articulated, and AdvPs occupy the specifiers of dedicated functional heads. A barer clause structure, by contrast, will be adopted here, along with the more traditional assumption that AdvPs are adjuncts. However, some of the substantive claims of the cartographic analyses can be adapted straightforwardly to this more traditional framework of assumptions. Consider the AdvPs *frankly*, *then*, *suddenly*, and *well*. According to the Cinque hierarchy, they occupy the specifiers of the functional heads  $\text{Mood}_{\text{SpeechAct}}^0$ ,  $\text{T}_{\text{Future}}^0$ ,  $\text{ASP}_{\text{Inceptive(I)}}^0$ , and  $\text{Voice}^0$ , respectively. A natural way to implement this treatment of these AdvPs in a noncartographic framework would be to posit that they adjoin to MoodP, TP, AspP, and VoiceP, respectively. (For noncartographic approaches to the syntax of adverbials,

see Ernst 2002 and Svenonius 2002, a.m.o.)

If this analysis of those adverbials is correct for Janitzio P’urhepecha, then when the equivalents of two of them have been left-adjoined to their respective hosts in this language, the putatively higher adverbial should precede the putatively lower one, and exchanging them in the linear string should produce a less acceptable result. This prediction is correct, as shown below.

The adverbial *sesimindu uandantani ia* ‘frankly / honestly / to tell you the truth’ (a nonfinite clause meaning, semiliterally, ‘to inform very well’) can precede the adverb *jimamberi* ‘then’ ((13a)). Reversing these two adverbials yields a much less acceptable result ((13b)).

(13) *Sesimindu uandantani ia* ‘frankly, honestly’ (MoodP) precedes *jimamberi* ‘then’ (TP)

- a. **Sesi=mindu uandanta-ni ia** Elena **jimamberi**  
 well=very inform-INF already Elena then  
 uera-si-Ø-ti ereta-rhu.  
 go.out-PFV-PRS-IND3 town-LOC  
 ‘Honestly, Elena then left town.’
- b. \*\***Jimamberi** Elena **sesi=mindu uandanta-ni ia**  
 then Elena well=very inform-INF already  
 uera-si-Ø-ti ereta-rhu.  
 go.out-PFV-PRS-IND3 town-LOC  
 ‘Then Elena honestly left town.’

Although the deviance of *jimamberi* ‘then’ ... *sesimindu uandantani ia* ‘honestly’ order is not always quite as strong as it is in (13b), this order is consistently judged less acceptable than the opposite order.

*Jimamberi* ‘then’, in turn, can precede *isku jauembarini* (or *isku jauemberini*) ‘suddenly’ ((14a)). Here too, reversing the expected order produces a decrease in acceptability ((14b)).

(14) *Jimamberi* ‘then’ (TP) precedes *isku jauembarini* ‘suddenly’ (AspP)

- a. Elena **jimamberi** mitanta-si-∅-ti      **isku jauembarini** omutakua-ni  
 Elena then                    open-PFV-PRS-IND3 suddenly                    door-ACC  
 k’umanchiku-eri.  
 house-GEN  
 ‘Elena then suddenly opened the door to the house.’
- b. ?Elena **isku jauembarini** mitanta-si-∅-ti      **jimamberi** omutakua-ni  
 Elena suddenly                    open-PFV-PRS-IND3 then                    door-ACC  
 k’umanchiku-eri.  
 house-GEN  
 ‘\*Elena suddenly then opened the door to the house.’

Finally, *isku jauembarini* ‘suddenly’ can precede manner adverbials such as *exeparini* ‘carefully’, *eskaparini* ‘carefully’, and *ikichakueni jasi* ‘badly’. If the opposite order is used instead, the sentence typically becomes degraded. This is shown in (15-17).

(15) *Isku jauembarini* ‘suddenly’ (AspP) precedes *exeparini* ‘carefully’ (VoiceP)

- a. Emilia **isku jauembarini** apojsita-si-∅-ti      **exeparini** koki-ni  
 Emily suddenly                    put-PFV-PRS-IND3 carefully      toad-ACC  
 uitsakua-rhu.  
 grass-LOC  
 ‘Emily suddenly carefully put the toad on the grass.’
- b. ??Emilia **exeparini** apojsita-si-∅-ti      **isku jauembarini** koki-ni  
 Emily carefully      put-PFV-PRS-IND3 suddenly                    toad-ACC  
 uitsakua-rhu.  
 grass-LOC  
 ‘\*Emily carefully suddenly put the toad on the grass.’

(16) *Isku jauembarini* ‘suddenly’ (AspP) precedes *eskaparini* ‘carefully’ (VoiceP)

- a. Berta **isku jauembarini** mikanta-si-∅-ti      **eskaparini** takukata  
 Bertha suddenly                    close-PFV-PRS-IND3 carefully      book  
 k’eri-ni.  
 big-ACC  
 ‘Bertha suddenly carefully closed the big book.’



- b. ?Berta **eskaparini** mikanta-si-∅-ti **isku jauembarini** takukata  
 Bertha carefully close-PFV-PRS-IND3 suddenly book  
 k'eri-ni.  
 big-ACC  
 ‘\*Bertha carefully suddenly closed the big book.’

(17) Isku jauembarini ‘suddenly’ (AspP) precedes ikichakueni jasi ‘badly’ (VoiceP)

- a. Ikinari **isku jauembarini** unta-si-∅-ti **ikichakueni jasi**  
 Ikinari suddenly fix-PFV-PRS-IND3 badly  
 uaxantsikua-ni.  
 chair-ACC  
 ‘Ikinari suddenly fixed the chair badly.’
- b. ↓Ikinari **ikichakueni jasi** unta-si-∅-ti **isku jauembarini**  
 Ikinari badly fix-PFV-PRS-IND3 suddenly  
 uaxantsikua-ni.  
 chair-ACC  
 ‘\*Ikinari badly suddenly fixed the chair.’

Although the judgments are mostly gradient, and subtle at times, the contrasts are quite telling. When an adverbial (AdvP<sub>A</sub>) precedes another adverbial (AdvP<sub>B</sub>) that was hypothesized above to adjoin to a lower clausal projection,<sup>1</sup> the result is perfect. When the adverbials are exchanged in the linear string (AdvP<sub>B</sub> ≫ AdvP<sub>A</sub>), the result is typically less acceptable. This is exactly as expected on the hypothesis laid out above—namely, that *sesimindu uandantani ia* ‘honestly’ adjoins to MoodP, *jimamberi* ‘then’ to TP, *isku jauembarini* ‘suddenly’ to AspP, and manner adverbials to VoiceP. These adverbials, then, can indeed be reliably used as syntactic landmarks, and our picture of Janitzio P’urhepecha clause structure may be revised along the lines shown below:

<sup>1</sup>The focus here is on sentences such as (13, 17), in which it is reasonably clear that none of the adverbials are *right*-adjoined to a clausal projection.

(18) *Janitzio P'urhepecha clause structure (first revision)*

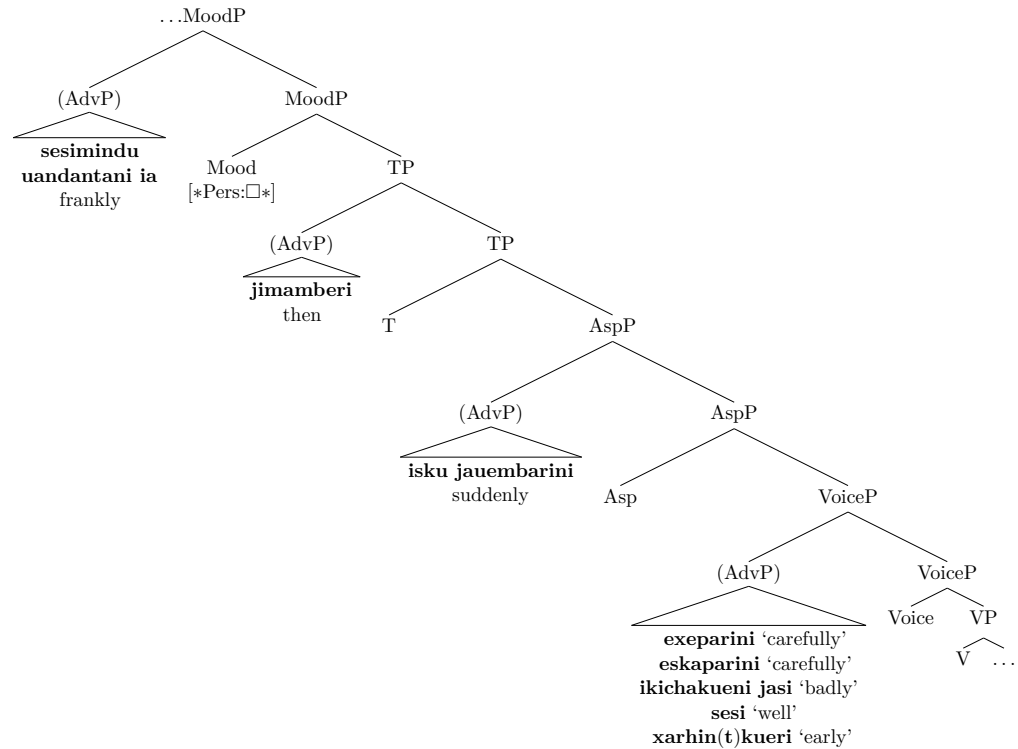

Note that *AdvP* is used here as a cover term for *adverbial* phrases, which almost certainly do not all belong to the same syntactic category in Janitzio P'urhepecha.

### 2.3 Verb positions

A few words are in order about the position of the (finite) verb. This element can appear to the right of low (VoiceP-adjoined) adverbials such as *ikichakueni jasi* 'badly', indicating that it can surface in a very low position:

- (19) Karlusi **ikichakueni jasi** atanta-si-Ø-ti tsintsikata-ni.  
 Carl badly paint-PFV-PRS-IND3 wall-ACC  
 'Carl painted the wall badly.'

This position must be Voice rather than V, since V moves to Voice.<sup>2</sup> But the verb can

<sup>2</sup>This cannot be demonstrated on the basis of the data shown so far, but the evidence is the following.

be realized in several other positions as well. It can surface between VoiceP-adverbials and the AspP-adverbial *isku jauembarini* ‘suddenly’ ((15a), (16a), (17a)), indicating that it can be realized in Asp. It can alternatively surface between the AspP-adverbial *isku jauembarini* ‘suddenly’ and the TP-adverbial *jimamberi* ‘then’ ((14a))—i.e., in T. Finally, it can surface to the left of *jimamberi* ‘then’ ((20)), suggesting that it can also be realized in Mood. (For a detailed investigation of how high the verb can raise in Janitzio P’urhepecha, see Appendix A.)

- (20) Materu uexurini ereka-a-∅-ka=sī            materu ereta-rhu.  
 another year    live-FUT-PRS-IND1=pS another town-LOC.  
 Erenta-a-∅-ka=sī            **jimamberi** sanderu sesi.  
 live-FUT-PRS-IND1=pS then            more    well  
 ‘Next year we’ll live in another town. Then we’ll live better.’

Although (20) was judged fully acceptable, it is perhaps more typical for verb-*jimamberi* order to be judged a bit marginal compared to *jimamberi*-verb order:

- (21) Uexurini jimbari erenta-a-∅-ka=sī            materu k’umanchikua-rhu. Nande  
 year    new    live-FUT-PRS-IND1=pS other    house-LOC.            mother  
 {jimamberi pia-a-∅-ti            / ? pia-a-∅-ti            **jimamberi**} ma  
 {then    buy-FUT-PRS-IND3 / ? buy-FUT-PRS-IND3 then}            a  
 kojtsitarakua k’eri.  
 table            big  
 ‘In the new year we’ll live in a different house. Mom will then buy a big table.’

Summarizing, then, the finite verb can be realized in Voice, Asp, T, or Mood. (At present, the verb/adverbial ordering facts just discussed are the only evidence available for the verb-raising operations posited. A logically possible alternative analysis on which

---

In Chapter 5, it will be shown that the subject of an embedded finite CP can raise into the matrix clause, becoming an object of this clause (this is the phenomenon of *hyperraising to object*), and that the position it targets is a specifier position of *vP* (a projection lower than VoiceP but higher than VP, whose existence in Janitzio P’urhepecha will be argued for in Chapter 5). Sentences (178) and (180), in which the verb immediately precedes the hyperraised DP in [Spec,*vP*] (and is itself immediately preceded by a manner adverbial left-adjoined to VoiceP), are acceptable, but (181), which attempts to place the verb to the immediate right of the hyperraised DP in [Spec,*vP*], is highly degraded. This demonstrates that V obligatorily raises to Voice in Janitzio P’urhepecha. The interested reader is referred to the example sentences in Chapter 5 just mentioned.

it is not the verb that moves but the adverbials will not be considered here, primarily because it would not be straightforward on such an analysis to explain why—or even to state the generalization that—the adverbials are rigidly ordered with respect to one another.)

Whichever of these head positions the verb word surfaces in, it always conforms to the same morphological template: *Root – (Derivational Suffixes) – Voice – Aspect – Tense – Mood+Person* ((11)). Even when the verb word occupies a relatively low position (e.g., Voice), it bears suffixes that are the reflexes of higher syntactic heads, in conformity with the Mirror Principle-compliant template just mentioned. In other words, there is no correlation between the verb word’s position and its internal complexity (except in the trivial sense that it always has the same complex internal structure, regardless of the position it occupies). This strongly suggests that the interaction between head movement and word-building is not trivially straightforward (cf. Angeles 2017, §4-5; Arregi & Pietraszko 2018; Gribanova & Harizanov to appear). One way to capture this (in the nonlexicalist framework assumed here) is as follows. V obligatorily moves to Voice. Optionally, further head movement can take place—to Asp, to T, or even to Mood. However much word-building is not done by head movement in a particular derivation is done by (possibly iterated) postsyntactic Lowering (Embick & Noyer 2001, Hankamer 2011, Ostrove 2015, 2018, Lebowksi 2016). At any rate, regardless of how exactly the pieces of the verb word are put together, what is important for present purposes is that, as mentioned above, the verb word can be *realized* in Voice, Asp, T, or Mood.

Because V, Voice, Asp, T, and Mood are ultimately packaged together into a single morphophonological word, a *Natural Language and Linguistic Theory* reviewer asks whether they might not be base-generated as a cluster, as Haider (2003, 2010) proposes that Dutch verb clusters are. Adapting Haider’s analysis to Janitzio P’urhepecha, we might posit that each head selects the next head down and projects as a *head* (rather

than as a phrase), yielding the base-generated complex head shown in (22), with the arguments being projected as sisters of (projections of) the entire complex head.

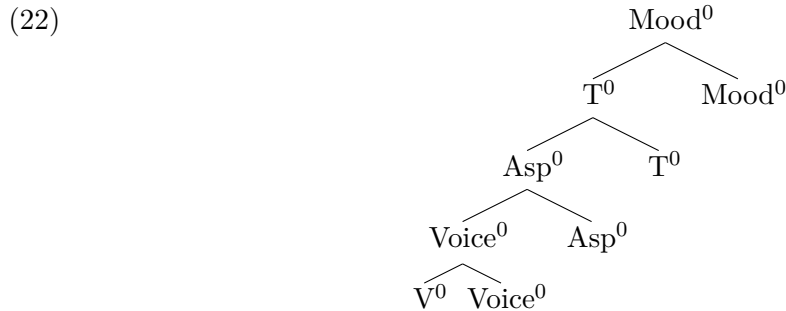

Evidence against this alternative is provided by the facts discussed above about the placement of the verb word with respect to adverbials. The landmark adverbials identified in §2.2 are rigidly ordered, and the verb word can surface in various positions in between them (which often results in its being linearly separated from the internal arguments, as in (15a), (16a), (17a), and (14a)). This is strongly suggestive of head movement. Therefore, if the verb word were base-generated as a head cluster ((22)), it would apparently still be necessary to posit that it can undergo head movement (sometimes multiple times in a single derivation)—but this would remove much of the motivation for the cluster analysis.

The reviewer also mentions a second alternative analysis, on which the voice, aspect, tense, and mood suffixes each spell out a component (presumably a feature) of a single complex AgrS head (cf. Pollock 1989), to which V moves. As the reviewer acknowledges, though, “this raises issues for adverb placement.” Like the cluster analysis ((22)), the complex-AgrS-head analysis does not on its own account for the fact that the verb word can occupy a number of different head positions in between the landmark adverbials. To capture this, it would be necessary to posit that the V-AgrS complex can undergo further head movement (sometimes multiple times), undercutting the motivation for positing the complex AgrS head in the first place.

For these reasons, neither the cluster analysis nor the complex-AgrS-head analysis will be adopted here.

## 2.4 Polarity particles

Before concluding this section, it will be worthwhile to make some observations about polarity particles that will give us a few more landmarks to orient ourselves by. Janitzio P'urhepecha has, among others, the polarity particles *ambu* ‘not’ and *k'o*, an emphatic affirmative particle that seems to express something like *verum focus* (Höhle 1992, Samko 2016). These particles precede the finite verb:

- (23) a. Iasi **ambu** ts'irakuare-∅-∅-∅.  
 today not be.cold-PFV-PRS-IND  
 ‘It’s not cold today.’
- b. Iasi **k'o** ts'irakuare-si-∅-ti.  
 today AFFM be.cold-PFV-PRS-IND3  
 ‘Today it IS cold.’

*Ambu* ‘not’ and *k'o* ‘AFFM’ seem to merge higher than Mood; this is particularly clear in (23b), where Mood surfaces overtly (as the third-person indicative mood morpheme *-ti*). A natural hypothesis is that these particles instantiate a functional category Pol(arity), the next functional head up above Mood ((24)). (On Pol heads, see Pollock 1989, Laka 1990, Zanuttini 1997, Lebowski 2016, and Desai 2017b; for related investigations, see Gianollo 2016, Hedding 2017, and Vincent 2018.)

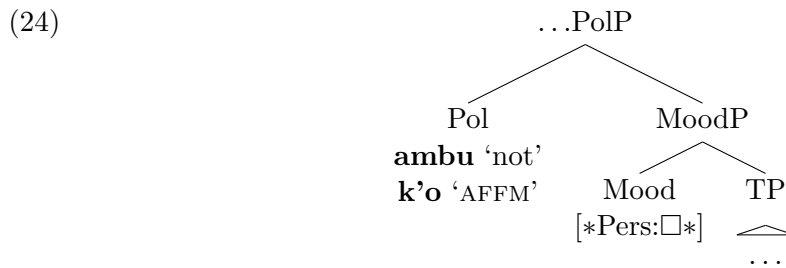

If this is so, a question arises as to whether the finite verb—which has been shown to be able to surface as high as Mood—can alternatively surface one head higher, in Pol (in virtue of having incorporated into Pol, for example). At least when Pol is overt, the answer is no. This is illustrated here with *ambu* ‘not’. If an attempt is made to incorporate the finite verb into *ambu* ‘not’, and the would-be complex head this gives rise to is pronounced as a single prosodic word, the result is unacceptable:

- (25) \*Iasĩ ts'irakuare-∅-∅-∅-ambu.  
 today be.cold-PFV-PRS-IND-not  
 int. ‘It’s not cold today.’

(The test run in (25) assumes that, following head movement, the Pol head *ambu* ‘not’ would be linearized as a suffix. If it were linearized as a prefix, then the test probably could not be run: word-level stress falls on the first or second syllable in Janitzio P’urhepecha [the first in the case of *ambu* ‘not’], and it is doubtful that a hypothetical sentence □*Iasĩ ambuts'irakuare*, with the verb raising to Pol, could be distinguished from a version of (23a) without the verb raising to Pol but with verum focus on *ambu* ‘not’.)

The result in (25) leads to the expectation that the verb should be unable to surface in a head position higher than Pol. It probably should not be able to reach such a head position by skipping over Pol, given the generally strictly local nature of head movement (at least of this “word-building” type; cf. the Head Movement Constraint [Travis 1984; Angeles 2017, §4-5; Arregi & Pietraszko 2018; and Gribanova & Harizanov to appear]). And it should not be able to reach a head position higher than Pol by incorporating into Pol and then exorporating from it, because the first step (incorporation) is impossible ((25)). Therefore, the verb should be unable to precede *ambu* ‘not’ even if these two elements are pronounced as separate prosodic words. This prediction is correct:

- (26) \*Iasi ts'irakuare-∅-∅-∅ **ambu**.  
 today be.cold-PFV-PRS-IND not  
 int. 'It's not cold today.'

At this point a small revision is needed to our clause structure. Given that Pol is higher than Mood, the working hypothesis from above that *sesimindu uandantani ia* 'honestly' adjoins to MoodP predicts that polarity particles should obligatorily precede this adverbial. In fact, the opposite is true, as shown for *ambu* 'not' in (27) and for *k'o* 'AFFM' in (28).

- (27) *Sesimindu uandantani ia* 'honestly' must precede *ambu* 'not'

- a. **Sesi=mindu uandanta-ni ia** ambu aparekuari-na-∅-ki.  
 well=very inform-INF already not be.hot-PROG-PRS-IND  
 'It's honestly not hot [out].'
- b. \*Ambu **sesi=mindu uandanta-ni ia** aparekuari-na-∅-ki.  
 not well=very inform-INF already be.hot-PROG-PRS-IND  
 int. 'It's honestly not hot [out].' / 'It's not honestly hot [out].'

- (28) *Sesimindu uandantani ia* 'honestly' must precede *k'o* 'AFFM'

- a. **Sesi=mindu uandanta-ni ia** k'o aparekuare-si-∅-ti.  
 well=very inform-INF already AFFM be.hot-PFV-PRS-IND3  
 'It honestly IS hot [out].'
- b. \*K'o **sesi=mindu uandanta-ni ia** aparekuare-si-∅-ti.  
 AFFM well=very inform-INF already be.hot-PFV-PRS-IND3  
 int. 'It honestly IS hot [out].'

This shows that *sesimindu uandantani ia* 'honestly' does not in fact adjoin to MoodP, but rather adjoins at least as high as PolP. Taking it to adjoin to PolP, we arrive at the following revised clause structure for Janitzio P'urhepecha:



(29) *Janitzio P'urhepecha clause structure (second revision)*

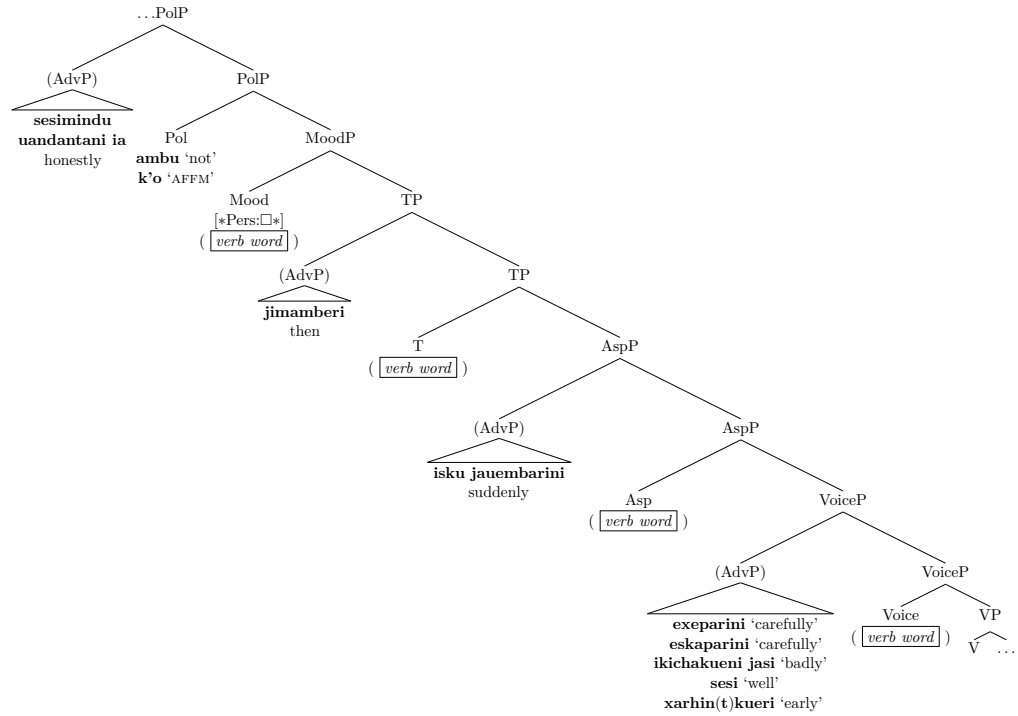

It will be tentatively assumed here that Pol is present even in finite clauses in which it is not overt; in these cases it presumably contributes ordinary, nonemphatic affirmative polarity. This assumption is supported by the fact that *sesimindu uandantani ia* ‘honestly’, which was just argued to adjoin to PolP, can occur in clauses with no overt polarity particle:

- (30) Iamindu uatsapi-cha **sesi=mindu uandanta-ni ia** sesi  
 all child-PL well=very inform-INF already well  
 t'ire-si-∅-ti=sī.  
 eat-PFV-PRS-IND3=pS  
 ‘All the kids honestly ate well.’

Although it is possible in principle that the verb can (or must) raise into Pol precisely when Pol is not overt, it is reasonable to assume, in the absence of evidence to the contrary, that the verb can only ever raise as high as Mood. (The former claim is made by Mitchell [2006, §2.1] for Finno-Ugric. In the relevant languages, the verb agrees with

the subject, unless a polarity particle is present, in which case the polarity particle agrees with the subject and the verb is uninflected. Mitchell, assuming that subject agreement takes place in a Spec-head configuration, concludes that the polarity particle and the verb compete for a single position—i.e., that the verb raises into this position precisely when no overt polarity particle is present. This analysis will not be adopted for Janitzio P’urhepecha here, because polarity particles do not bear agreement in this language, and because subject agreement in Janitzio P’urhepecha is more straightforwardly analyzed as taking place under Agree than as occurring in a Spec-head configuration [since Mood agrees with the subject in person even when the subject is lower than [Spec,MoodP], as will become clear in §3.1.)

Given that the finite verb cannot be realized in or higher than Pol, the clause structure in (29) predicts that it should also be unable to precede *sesimindu uandantani ia* ‘honestly’, which is analyzed there as a PolP-adverbial. This prediction is correct:

- (31) ?\*Xumo xepe-si-Ø-ti                    **sesi=mindu uandanta-ni ia**            sanderu  
 Xumo be.lazy-PFV-PRS-IND3 well=very    inform-INF    already more  
 eska iamindu-eecha.  
 than all-PL  
 int. ‘Xumo’s frankly lazier than everyone else.’

The problem with (31) is not that *sesimindu uandantani ia* ‘frankly’ is too prosodically heavy to occur sentence-internally: it can perfectly well be preceded by the subject ((32)).

- (32) Xumo **sesi=mindu uandanta-ni ia**            sanderu xepe-si-Ø-ti  
 Xumo well=very    inform-INF    already more    be.lazy-PFV-PRS-IND3  
 eska iamindu-eecha.  
 than all-PL  
 ‘Xumo frankly is lazier than everyone else.’

For other analyses of clause structure that are broadly compatible with the one in (29), see Compton and Pittman 2010 (for Inuit); Gribanova 2013 (for Russian); Tucker 2013 (for Maltese); Legate 2014 (for Acehnese); Hamilton 2015 (for Mi’gmaq);

[Kalivoda 2015](#) (for Teotitlán del Valle Zapotec); [Ostrove 2016b, 2017a,b](#) (for San Martín Peras Mixtec); [Baclawski 2017](#) (for Eastern Cham); [Bruening 2017](#) (for Passamaquoddy-Maliseet); [Desai 2017a,b](#) (for Gujarati); [Hedding 2017](#) (for Somali); [McCloskey 2017](#) (for Irish); [Adler, Foley, Pizarro-Guevara, Sasaki, and Toosarvandani 2018](#) (for Santiago Laxopa Zapotec); [Clem 2018](#) (for Amahuaca); [Hammerly 2018](#) (for Southwestern Ojibwe); [Gribanova 2018](#) (for Uzbek); [Kalivoda and Zyman 2018](#) (for Latin); [Ostrove 2018](#) (for Irish); [Pietraszko 2018](#) (for Ndebele and Swahili); [Borise and Polinsky in press](#) (for Georgian, though see also [Flinn 2017](#)); [Danckaert to appear](#) (for Latin); [Haugen to appear](#) (for Classical Nahuatl); and [Ostrove submitted](#) (for Scottish Gaelic), a.m.o.

Needless to say, there is much more to uncover about Janitzio P’urhepecha clause structure. In particular, nothing has been said here about the left periphery ([Rizzi 1997](#); see [Capistrán 2002](#) on leftward focus movement, topicalization, left-dislocation, and hanging topics in Lake Pátzcuaro P’urhepecha, of which Janitzio P’urhepecha is a variety). But the structure in [\(29\)](#) will suffice for present purposes.

## Chapter 3

# Profligate subject movement

This chapter shows that the subject in Janitzio P’urhepecha can either remain in its base position ([Spec, VoiceP] for external argument subjects) or raise to any of a wide array of specifier positions in the inflectional layer of the clause (cf. Rizzi 1997:281; see Cable 2012 for an investigation of a very similar phenomenon in Dholuo). The chapter then asks what this “profligate subject movement” reveals about the driving force for movement, and argues that it receives a straightforward and empirically adequate analysis under Enlightened Self-Interest, but not under Greed or Labeling.

### 3.1 Identifying the subject positions

The first step in this investigation will be to determine where in the structure of a Janitzio P’urhepecha clause the subject can surface overtly.

#### 3.1.1 [Spec, VoiceP]

Although many of the sentences examined in the previous chapter were subject-initial—and, indeed, this seems to be common—Janitzio P’urhepecha allows its subjects, like its verbs, to surface extremely low, to the right of VoiceP-adverbials such as *xarhin(t)kueri*

‘early’ (but to the left of VP-internal material such as the direct object):

- (33) Uitsidekua mita(a)nta-si-Ø-ti=sī      **xarhintkueri** iamindu uariti-cha  
 yesterday open(pO)-PFV-PRS-IND3=pS early      all woman<sub>RESP-PL</sub>  
 ts”im-eri meiapekue-echa-ni.  
 they-GEN store-PL-ACC  
 ‘Yesterday all the women opened up their stores early.’

This strongly suggests that the subject can surface in [Spec, VoiceP], which is presumably its base position when it is an external argument (as *iamindu uariticha* ‘all the women’ is in (33)).

### 3.1.2 [Spec, AspP]

The subject can also surface between VoiceP-adverbials like *sesi* ‘well’ and the AspP-adverbial *isku jauembarini* ‘suddenly’—i.e., in [Spec, AspP]:

- (34) Unta-si-Ø-ti=sī      **isku jauembarini** iamindu iurhitskiri-cha **kanekua**  
 fix-PFV-PRS-IND3=pS suddenly      all young.woman-PL      very  
**sesi** ts”im-eri kojtsitarakue-echa-ni.  
 well they-GEN table-PL-ACC  
 ‘All the young women suddenly fixed their tables very well.’

### 3.1.3 [Spec, TP]

A third possible position for the subject is between the AspP-adverbial *isku jauembarini* ‘suddenly’ and the TP-adverbial *jimamberi* ‘then’—i.e., in [Spec, TP]:

- (35) Sesi=mindu uandanta-ni ia      **jimamberi** iamindu uatsapi-cha  
 well=very inform-INF already then      all child-PL  
**isku jauembarini** ue-nta-si-Ø-ti=sī.  
 suddenly      go.out-ITER-PFV-PRS-IND3=pS  
 ‘Honestly, then all the kids suddenly went back out.’

### 3.1.4 [Spec,MoodP]

A fourth possible position for the subject is between the TP-adverbial *jimamberi* ‘then’ and the PolP-adverbial *sesimindu uandantani ia* ‘honestly’ ((36)). This will be tentatively analyzed here as indicating that the subject has the option of surfacing in [Spec,MoodP].

- (36) **Sesi=**mindu uandanta-ni ia      iamindu kustati-cha **jimamberi**  
well=very    inform-PL    already all musician-PL      then  
erenta-a-Ø-ti=sĩ      materu ereta-rhu.  
live-FUT-PRS-IND3=pS other    town-LOC  
‘Honestly, all the musicians will (by) then live in another town.’

(There are other analytical options here, however. The subject in (36) could in principle be in an outer specifier of TP, formed after the adjunction of *jimamberi* ‘then’ to TP. Alternatively, it could be in an inner specifier of PolP, formed before the adjunction of *sesimindu uandantani ia* ‘honestly’ to PolP. Perhaps more than one of these analyses is available: the sentence could be structurally two- or three-ways ambiguous. The quandary seems difficult to escape given the logic of Bare Phrase Structure [Chomsky 1995b; see also Carnie 2000, Hornstein & Nunes 2008, Jayaseelan 2008, a.m.o.], which leads us to expect that the adjunction of an adverbial to a projection of a head H should be able to either precede or follow, derivationally, the internal merger of an XP with the highest available projection of H—i.e., movement of the XP to “[Spec,HP].” It should, however, be possible to tease apart some of the possibilities just mentioned if an adverbial is discovered that invariably adjoins to MoodP in Janitzio P’urhepecha.)

### 3.1.5 [Spec,PolP]

Finally, the subject can also precede the PolP-adverbial *sesimindu uandantani ia* ‘honestly’:

- (37) Iamindu uatsapi-cha **sesi=mindu uandanta-ni ia** sesi  
 all child-PL well=very inform-INF already well  
 t'ire-si-∅-ti=sī.  
 eat-PFV-PRS-IND3=pS  
 'All the kids honestly ate well.'

A natural initial analysis of this is that a subject immediately preceding that PolP-adverbial is in an outer specifier of PolP, formed after the adjunction of the adverbial to PolP.

The hypothesis that the subject can occupy [Spec,PolP] predicts that it should be able to precede a polarity particle (i.e., a Pol head). This is correct:

- (38) Ana **ambu** u(a)nta-∅-∅-∅ p'orhechi-cha-ni, peru...  
 Anna not fix(pO)-PFV-PRS-IND pot-PL-ACC, but...  
 'Anna didn't fix the pots, but...'

### 3.1.6 Summary

To recapitulate, we have identified five subject positions in Janitzio P'urhepecha (boxed in (39) below), on the basis of where in the linear string the subject can appear with respect to various adverbials and other elements.

(39) *Janitzio P'urhepecha clause structure (subject positions boxed)*

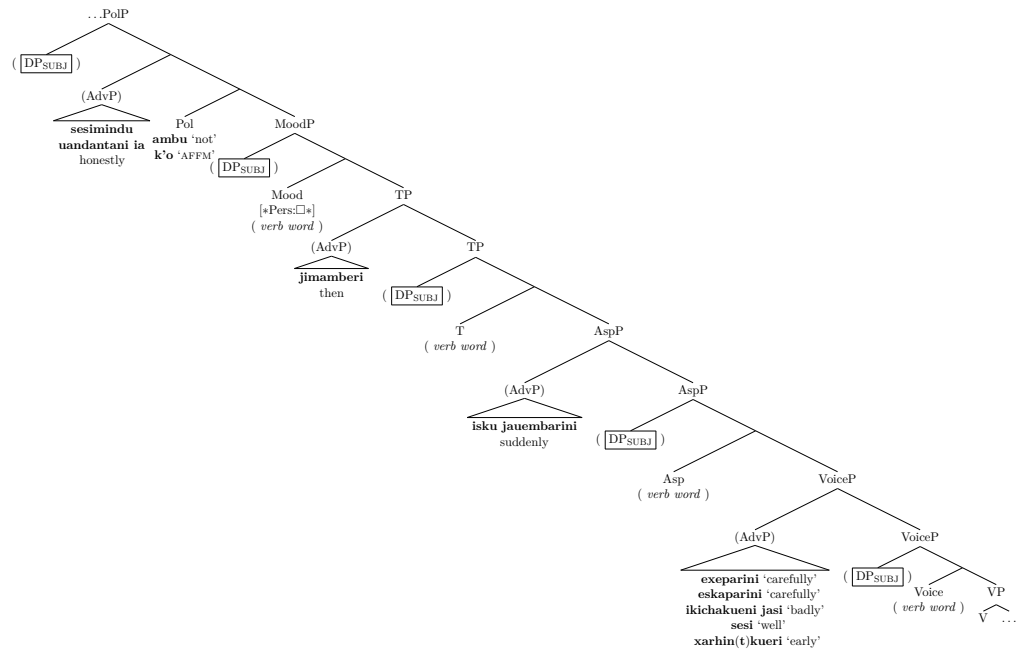

This dissertation uses the term *DP* in connection with Janitzio P'urhepecha largely for convenience. The question of how much evidence there is for this exact category in the language would be well worth investigating. See [Bošković 2008](#) for arguments that some languages have NPs but not DPs, [Bošković and Šener 2014](#) for arguments to this effect for Turkish specifically, and [Bruening 2009](#) for arguments against the DP Hypothesis in general.

A *Natural Language and Linguistic Theory* reviewer asks whether Janitzio P'urhepecha has auxiliaries or modal verbs, since such elements might determine additional specifier positions in which the subject could appear. The language does have auxiliaries, but these follow the main verb (an example is *ja-* 'be' in [\(108b\)](#)), and therefore cannot be used to diagnose the position of subjects in leftward specifier positions. (The position of an Aux does not reveal whether a DP is in a leftward [Spec,AuxP] or somewhere else when AuxP is head-final.)



- (40) ...enga=sī **ts'inari**-rini      **ja-∅-p-ka**.  
 ...SUB=pS wake.up-PTCP.PRS be-PFV-PST-SJV  
 '...when they were awake.'

As for modal verbs, Janitzio P'urhepecha does have verbs with modal semantics, such as *uetari-* 'need, be necessary' ((41)) and *u-* 'be able' ((42)), but these are fully inflected like ordinary lexical verbs and may therefore be such.

- (41) Chiti munieka **uetari-sin-∅-di**      ioska-ni      iumu sentimetru sanderu eski  
 your doll      need-HAB-PRS-IND3 be.long-INF five centimeter more than  
 i.  
 this  
 'Your doll has to be 5 cm longer than this one.'
- (42) Tania xani      iostara-si-∅-ti      eska **u-a-∅-ti**      andaxa-ni  
 Tania so(.much) be.tall-PFV-PRS-IND3 that be.able-FUT-PRS-IND3 reach-INF  
 juchiti takukata-ni.  
 my book-ACC  
 'Tania is so tall that she can reach my book.'

On the syntax of subject positions crosslinguistically, see [Koopman and Sportiche 1991](#); [Bobaljik and Jonas 1996](#); [McCloskey 1997](#); [Alexiadou and Anagnostopoulou 1998](#); [Zubizarreta 1998](#), ch. 3; [Goodall 2001](#); [Kiss 2002](#); [Svenonius 2002](#); [Cardinaletti 2004](#); [Cable 2012](#); [Rizzi 2015](#); [Poole 2016](#); [Fong 2017a,b, 2018](#); and [Danckaert to appear](#), a.m.o.

### 3.2 What drives profligate subject movement?

On the standard assumption that the subject originates relatively low in the clause, within the thematic domain (the Internal Subject Hypothesis, [Koopman & Sportiche 1991](#), a.m.o.; see also [Rizzi 1997:281](#)), sentences of Janitzio P'urhepecha in which the subject occurs higher are most straightforwardly analyzed as derived by subject *movement*. This, of course, is the standard analysis of how the subject reaches its canonical

relatively high position in the inflectional layer in familiar languages such as English (in which this position is typically taken to be [Spec,TP]).

If, in Janitzio P’urhepecha, a subject occupying a position higher than [Spec, VoiceP] has moved there, a question arises as to what the driving force for this movement is. Answering this question will be the goal of the rest of this chapter. The discussion will proceed as follows. §3.2.1 will present an *altruistic* analysis of profligate subject movement in Janitzio P’urhepecha, on which this type of movement is driven by features of functional heads in the inflectional layer of the clause. §3.2.2 will present a *Greed-based* analysis of profligate subject movement, and will argue that it is untenable. Finally, §3.2.3 will present two *Labeling-based* analyses of profligate subject movement, and will argue that they too face serious problems. The conclusion, then, will be that profligate subject movement in Janitzio P’urhepecha is an instance of altruistic (target-driven) movement—i.e., movement driven by a feature of a c-commanding functional head, rather than by a feature of the moving element itself—and that this strongly supports the hypothesis that purely altruistic movement does indeed exist.

### 3.2.1 Hypothesis A: Profligate subject movement is *altruistic*

One possible analysis of profligate subject movement in Janitzio P’urhepecha is that it is an instance of *altruistic* movement—i.e., that it is driven by a feature of the head to whose specifier the subject moves. Let us see what such an analysis looks like concretely.

First, a structure of the following form is built up:

(43)

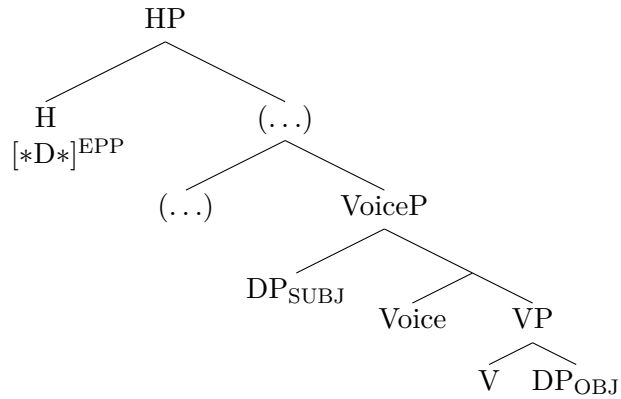

More precisely, what is built up first is the thematic domain (the VoiceP). (The subscripts “SUBJ” and “OBJ” in (43) are there only for ease of exposition; they have no syntactic reality.) Then, the functional heads making up the backbone of the inflectional layer begin to be merged in. The tree in (43) shows only a generic functional head H, for convenience: the analysis to be developed for “H” will apply equally to Asp, T, Mood, and Pol (the four functional heads to whose specifiers the subject can move). H bears a probe feature [\*D\*] with an EPP subfeature. (For various perspectives on and investigations of the notion “EPP,” see Grohmann, Drury, & Castillo 2000; Goodall 2001; Bošković 2002, 2004 [appendix]; McFadden 2003; Epstein, Pires, & Seely 2005; Landau 2007; Bailey 2010; Cable 2012; Chomsky 2013, 2015; Goto 2017b; Bošković & Messick to appear; and references therein, a.m.o.)

The probe feature [\*D\*] on H probes the c-command domain of H for a goal bearing the feature [D] (or, more precisely, the categorial feature [CAT:D]). It finds the closest suitable goal—the subject in its base position, [Spec, VoiceP]—and is thereby satisfied:

(44)

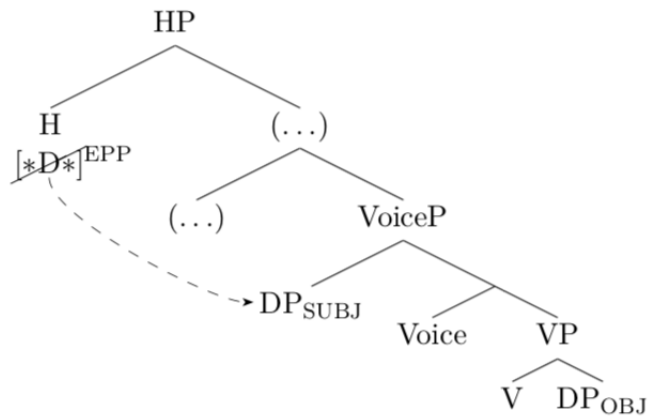

Then, the EPP subfeature of the probe feature  $[\ast D \ast]$  on H forces the goal (the subject) to internally merge with the highest available projection of H:

(45)

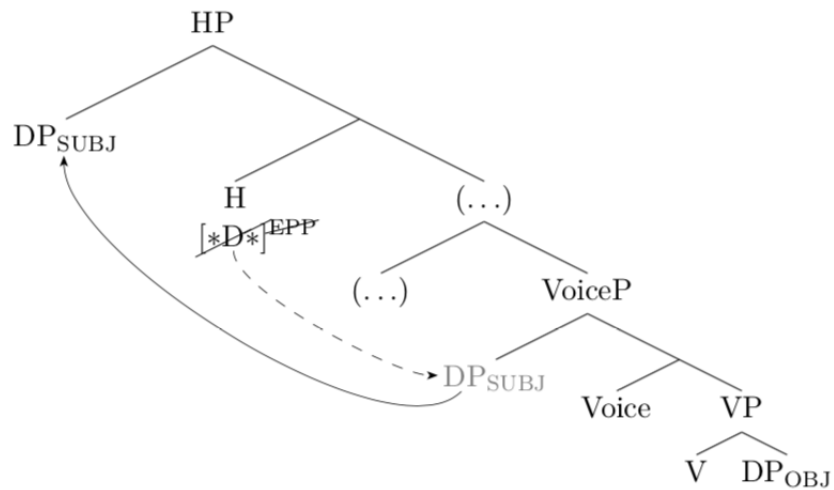

A probe will always find the closest goal bearing the feature it is probing for, where the notion “closest” is defined in terms of asymmetric c-command. (As discussed by [Erlewine to appear, fn. 15](#), this idea has a long history and has appeared in a variety of guises; cf. Relativized Minimality [[Rizzi 1990, 2001](#); see also [Bhatia, Kusmer, & Vostrikova 2016](#)], Shortest Move [[Chomsky 1993](#)], the Minimal Link Condition

[Chomsky 1995a, 2000], and Attract Closest [Pesetsky 2000].) Therefore, the altruistic movement analysis predicts that profligate subject movement in Janitzio P’urhepecha should display *intervention effects* of the sort that are a hallmark of A-movement.

There is evidence that this prediction is correct. Consider the following:

- (46) A: ¿Ambe ukurincha-si-Ø-ki uitsindekua?  
 what happen-PFV-PRS-INT yesterday  
 ‘What happened yesterday?’
- B<sub>1</sub>: **Tate** exeku-si-Ø-ti **i-ni** **parikutarakua-ni**. ✓SVO  
 dad fix-PFV-PRS-IND3 this-ACC car-ACC  
 ‘Dad fixed this car.’
- B<sub>2</sub>: ?**I-ni** **parikutarakua-ni** exeku-si-Ø-ti **Tate**. ?OVS  
 this-ACC car-ACC fix-PFV-PRS-IND3 dad  
 ‘#This car Dad fixed.’

The question in (46A) induces an information-structurally neutral context: the answer will be an “all-new” or “broad-focus” sentence, without any internal topic–comment or focus–presupposition articulation. With this in mind, consider the two answers shown in (46B<sub>1</sub>) and (46B<sub>2</sub>). In B<sub>1</sub>, the constituent order is SVO. Because the verb word can be realized in Voice (§2.3), this constituent order can be derived without moving any DPs (see the tree in (43)). But because the verb word can alternatively be realized in Asp, T, or Mood, and the subject can alternatively surface in [Spec,AspP], [Spec,TP], [Spec,MoodP], or [Spec,PolP], (46B<sub>1</sub>) is in fact structurally many-ways ambiguous. Crucially, on all the parses of (46B<sub>1</sub>) on which a DP has moved (regardless of whether or not the verb word is realized higher than Voice), it is the subject that has moved, not the object. So far, so good.

In (46B<sub>2</sub>), on the other hand, the constituent order is not SVO but OVS, and this sentence is clearly less acceptable in the context given than is (46B<sub>1</sub>). This is predicted by the altruistic analysis. On the altruistic analysis, H’s [\*D\*] feature will invariably find—and, therefore, its EPP subfeature will invariably attract—the subject,

not the object, because the subject asymmetrically c-commands the object prior to any movement. (As mentioned above, *H* is being used here as a cover term for the clausal functional heads Asp, T, Mood, and Pol.) This is shown in (47) below, which, for concreteness, shows a derivation in which the verb word is realized in Asp, and it is also Asp that bears  $[*D*]^{EPP}$  (though nothing forces these two properties to be shared by the same head in any particular derivation). (For ease of exposition, many of the derivational snapshots in this dissertation “anachronistically” show the verb word in the position in which it will eventually be realized. In (47), for example, the verb word is shown in Asp, even though it contains a third-person indicative mood morpheme *-ti* that is the realization of a Mood head, which, however, has not yet been merged into the structure. This expository simplification does not affect the analysis.)

(47)

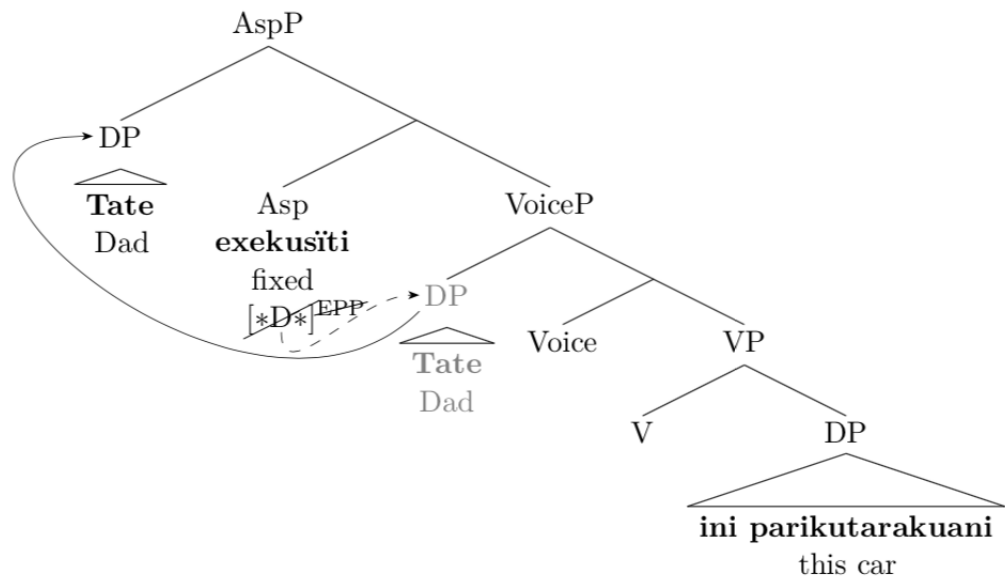

(Note that there is no evidence that the probing and Internal Merge operations shown in (47) have anything to do with assignment of nominative case, which at any rate is not realized overtly in Janitzio P’urhepecha. An analysis on which case is relevant to subject

movement in this language will be considered [and rejected] toward the end of §3.2.2.) Because probing is constrained by asymmetric c-command in this way, (46B<sub>2</sub>) is *undervivable* on any parse on which the object moves to [Spec,AspP], [Spec,TP], [Spec,MoodP], or [Spec,PolP] and the verb word is realized in Asp, T, or Mood (i.e., on which the object moves into the inflectional layer rather than the subject). The string in (46B<sub>2</sub>) can only be derived by realizing the verb word in Asp, T, or Mood and  $\bar{A}$ -moving the object to the left periphery—but this last operation is apparently obligatorily associated with marked information structure in Janitzio P’urhepecha (e.g., a topic interpretation for the object; cf. Capistrán 2002), which is incompatible with the information-structurally neutral context induced by the question in (46A). (The fact that (46B<sub>2</sub>) does presumably have a well-formed parse, involving topicalization—even if it is not felicitous on that parse in the context given—is likely at least part of the reason why (46B<sub>2</sub>) was merely judged degraded in that context rather than fully infelicitous.)

It is worth noting that the information-structure facts are similar in English, as shown by the idiomatic translations in (46): canonical SVO order is felicitous in the response, but topicalization, which yields OSV order in English, is infelicitous.

The intervention effect shown in (46) is by no means a peculiarity of that particular example: the effect is general. Another example of this kind of intervention effect is shown below:

- (48) A: ¿Ambe ukurincha-si-Ø-ki iasī?  
           what happen-PFV-PRS-INT today  
           ‘What happened today?’
- B<sub>1</sub>: Ataranta-si-Ø-ka=ni **juchiti chekagua-ni**. ✓VO  
       sell-PFV-PRS-IND1=1sS my big.canoe-ACC  
       ‘I sold my big canoe.’
- B<sub>2</sub>: ?**Juchiti chekagua-ni** ataranta-si-Ø-ka=ni. ?OV  
       my big.canoe-ACC sell-PFV-PRS-IND1=1sS  
       ‘#My big canoe, I sold.’

Interestingly, the object cannot be moved into the inflectional layer (as is attempted in (48B<sub>2</sub>)) even when the subject is covert. This provides a strong argument that at least one type of null subject in Janitzio P’urhepecha—the kind found in (48B<sub>1</sub>)—is a real, syntactically represented silent pronoun (*pro*).

Before concluding this discussion of the altruistic analysis of profligate subject movement, it will be worthwhile to move beyond the simplification “H” and confirm that the intervention effect currently under discussion is in fact induced by particular, precisely identifiable subject positions in Janitzio P’urhepecha—or, more precisely, by the functional heads determining them. As predicted by the altruistic analysis, this is indeed the case. The intervention effect is observed with movement to [Spec,AspP] ((49)), which linearly occurs between the VoiceP-adverbial *eskaparini* ‘carefully’ and the AspP-adverbial *isku jauembarini* ‘suddenly’:

- (49) A: ¿Ambe ukurincha-si-Ø-ki?  
 what happen-PFV-PRS-INT  
 ‘What happened?’
- B<sub>1</sub>: Uitsindekua **isku jauembarini** uatsapi **eskaparini** unta-si-Ø-ti  
 yesterday suddenly boy carefully fix-PFV-PRS-IND3  
 kukuchi-ni k’umanchikua-rhu.  
 jug-ACC house-LOC  
 ‘Yesterday the boy suddenly carefully fixed the jug at home.’
- B<sub>2</sub>: ?Uitsindekua **isku jauembarini** uatsapi **eskaparini** unta-si-Ø-ti  
 yesterday suddenly jug-ACC carefully fix-PFV-PRS-IND3  
uatsapi k’umanchikua-rhu.  
 boy house-LOC  
 int. ‘Yesterday the boy suddenly carefully fixed the jug at home.’

At this point, it might be objected that perhaps (49B<sub>2</sub>) is degraded in the context given not because DP-movement to [Spec,AspP] displays intervention effects but because the subject *uatsapi* ‘the boy’ occurs to the right of the verb (and to the left of the clause-final adjunct), but this constituent order is underivable given what has been said so



far (especially the clause structure that has been uncovered so far). However, the constituent order MANNER ADVERBIAL  $\gg$  VERB WORD  $\gg$  EXTERNAL ARGUMENT  $\gg$  OTHER VOICEP-INTERNAL MATERIAL (where “ $\gg$ ” = ‘precedes’) is *generally* possible in Janitzio P’urhepecha, suggesting that the external argument in fact originates not in the specifier of Voice but rather in the specifier of a lower, distinct head *v*. This, however, will be set aside for the moment for convenience; the matter will be taken up again in Chapter 5, where it will become relevant to the proper analysis of hyperraising to object in Janitzio P’urhepecha. Until then, *v* will be suppressed, and external arguments will continue to be base-generated in [Spec, VoiceP], for ease of exposition. (A related question that arises in this connection is whether the single argument of a verb expected to be unaccusative is generated in the complement position of V, as predicted by the now standard interpretation of the Unaccusative Hypothesis [Perlmutter 1978, Burzio 1986, Levin & Rappaport Hovav 1995, a.m.o.]. This question will be set aside here, however, because there are at this time no known reliable clausal landmarks below the VoiceP level in Janitzio P’urhepecha that could be used to investigate this particular matter, though one hopes that some will eventually be discovered.)

Returning to the intervention effect under investigation, it is also observed with movement to [Spec, TP] ((50)), which linearly occurs between the AspP-adverbial *isku jauembarini* ‘suddenly’ and the TP-adverbial *jimamberi* ‘then’:

- (50) A: Ka tatsekua ʔambe ukurincha-si-∅-ki?  
 and afterwards what happen-PFV-PRS-INT  
 ‘And then what happened?’
- B<sub>1</sub>: Sesi=mindu uandanta-ni ia      **jimamberi** uatsapi  
 well=very inform-INF already then      boy  
**isku jauembarini** kaka-si-∅-ti      kukuchi-ni k’umanchikua-rhu.  
 suddenly break-PFV-PRS-IND3 jug-ACC house-LOC  
 ‘Honestly, then the boy suddenly broke the jug at home.’

B<sub>2</sub>: ?Sesi=mindu uandanta-ni ia      **jimamberi** kukuchi-ni  
 well=very    inform-INF    already then      jug-ACC  
**isku jauembarini** kaka-si-Ø-ti      uatsapi k'umanchikua-rhu.  
 suddenly                    break-PFV-PRS-IND3    boy            house-LOC  
 int. 'Honestly, then the boy suddenly broke the jug at home.'

And the intervention effect is further observed with movement to [Spec,MoodP] ((51)), which linearly occurs between the TP-adverbial *jimamberi* 'then' and the PolP-adverbial *sesimindu uandantani ia* 'honestly':

(51) A: Ka tatsekua    ¿ambe ukurincha-si-Ø-ki?  
 and afterwards    what happen-PFV-PRS-INT  
 'And then what happened?'

B<sub>1</sub>: **Sesi=mindu uandanta-ni ia**      uatsapi **jimamberi**  
 well=very    inform-INF    already boy            then  
 isku jauembarini kaka-si-Ø-ti              kukuchi-ni k'umanchikua-rhu.  
 suddenly                    break-PFV-PRS-IND3    jug-ACC    house-LOC  
 'Honestly, then the boy suddenly broke the jug at home.'

B<sub>2</sub>: ?**Sesi=mindu uandanta-ni ia**      kukuchi-ni **jimamberi**  
 well=very    inform-INF    already jug-ACC    then  
 isku jauembarini kaka-si-Ø-ti              uatsapi k'umanchikua-rhu.  
 suddenly                    break-PFV-PRS-IND3    boy            house-LOC  
 int. 'Honestly, then the boy suddenly broke the jug at home.'

In Janitzio P'urhepecha, then, DP-movement into the inflectional layer displays pervasive intervention effects, as predicted by the altruistic analysis.

### 3.2.2 Hypothesis B: Profligate subject movement is *greedy*

The intervention effects just discussed will play a crucial role in our evaluation of the Greed-based analysis. But before that analysis is evaluated, it will, of course, be necessary to lay it out explicitly.

On the Greed-based analysis, profligate subject movement comes about because a D in Janitzio P'urhepecha—and therefore, derivatively, the DP it heads—can

optionally be endowed with any of four Bošković 2007–style unvalued features: [*u*Asp], [*u*T], [*u*Mood], or [*u*Pol]. (At the end of this section, an alternative Greed-based analysis will be considered on which the relevant unvalued feature is instead [*u*Case:□].) Suppose that, in a particular derivation, the subject DP is endowed with [*u*Asp]:

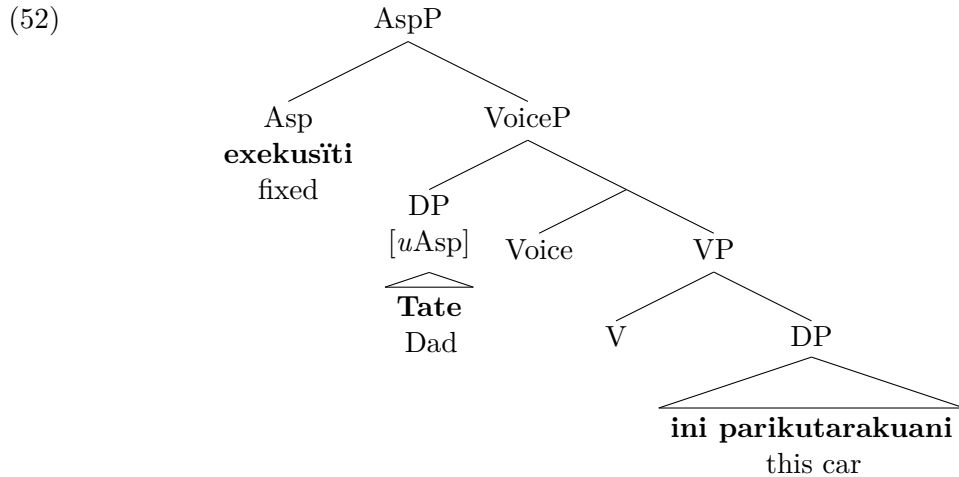

On Bošković’s (2007) analysis, not only does every probe bear an unvalued feature, but also, conversely, every element bearing an unvalued feature acts as a probe. That is, you’re a probe *iff* you bear an unvalued feature. (It would be easy to replace Bošković’s [*u*F] notation with the Heck & Müller 2007–style [*\*F\**] and [*\*F:□\**] notation used everywhere else in this dissertation, but Bošković’s [*u*F] notation will be retained here for continuity with his original proposal.) In (52), the subject DP cannot value its [*u*Asp] feature from where it is, because there are no potential goals bearing the feature [Asp] (more precisely, the categorial feature [CAT:Asp]) in its c-command domain. Therefore, the DP moves to a higher position from which it can probe again, potentially successfully—i.e., potentially with the result that its [*u*Asp] feature will actually be valued this time. (If the DP didn’t move in this way, it would eventually be spelled out with its [*u*Asp] feature unvalued, causing the derivation to crash.) Concretely, it internally merges with the highest available projection of Asp—i.e., in traditional terms, moves to [Spec,AspP]:

(53)

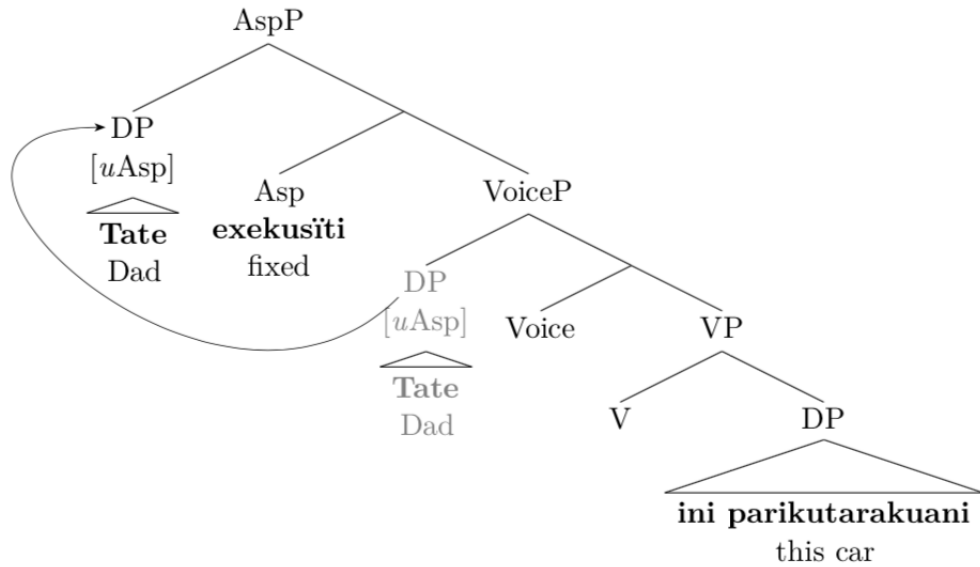

The DP's [uAsp] feature probes again. This time, however, the DP does c-command an element bearing [Asp]—namely, the Asp head itself. (It is quite possible that the mother of Asp—i.e., the traditional “ Asp' ”—is also an accessible and serviceable goal for the DP's [uAsp] probe, but this possibility will be set aside here, because nothing to follow will hinge on it.) Therefore, when the [uAsp] feature probes, it finds Asp and is valued (shown in (54) below as checking), and the derivation eventually converges.

(54)

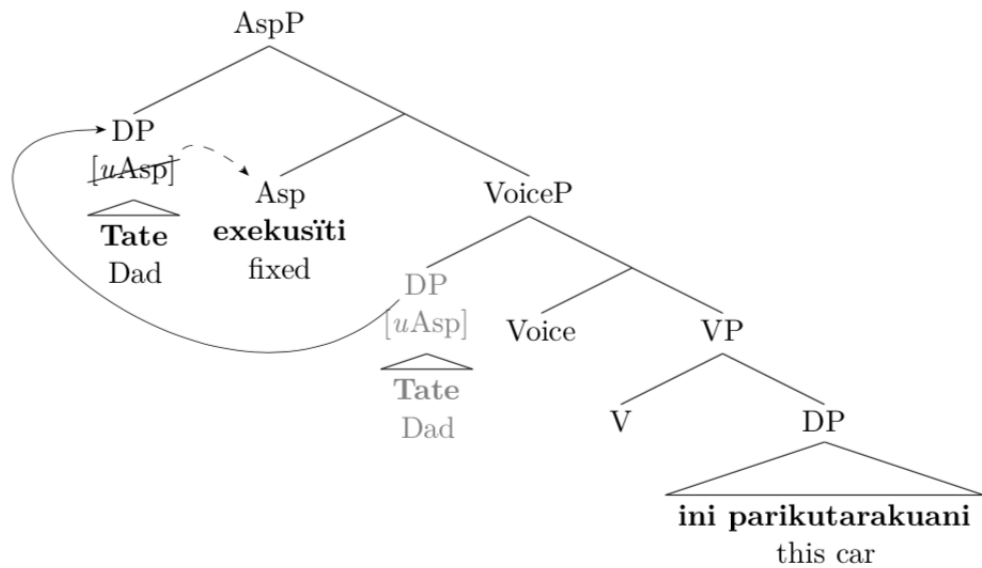

So far, so good. Unfortunately, the intervention effects discussed in §3.2.1 show that this Greed-based analysis overgenerates. Consider why. In the derivation just laid out, the subject was endowed with  $[uAsp]$ , but the object was not. But nothing prevents the opposite situation from arising: it is perfectly possible, on this analysis, for the object to be endowed with  $[uAsp]$  while the subject is not, as shown below.

(55)

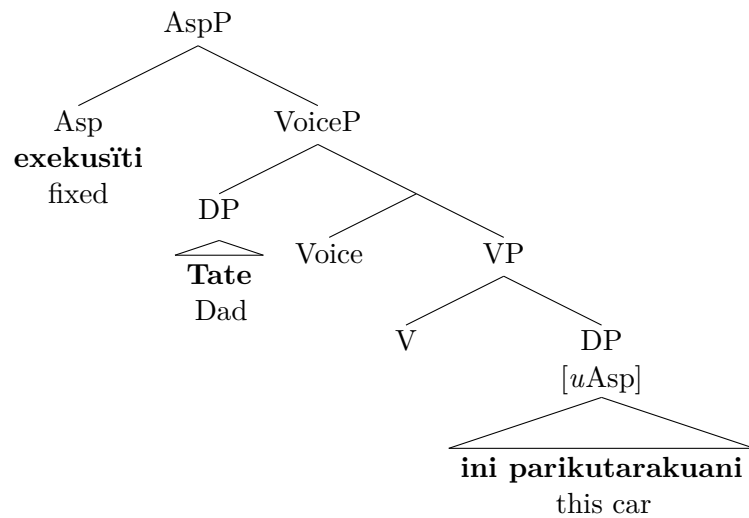

In this derivation, the object cannot value its [*uAsp*] feature from where it is, because there are no goals bearing [*Asp*] in its c-command domain. It therefore moves to a higher position and tries to value its [*uAsp*] feature under c-command from there. More specifically, it internally merges with the highest available projection of *Asp*, or, in traditional terms, moves to [*Spec,AspP*]:

(56)

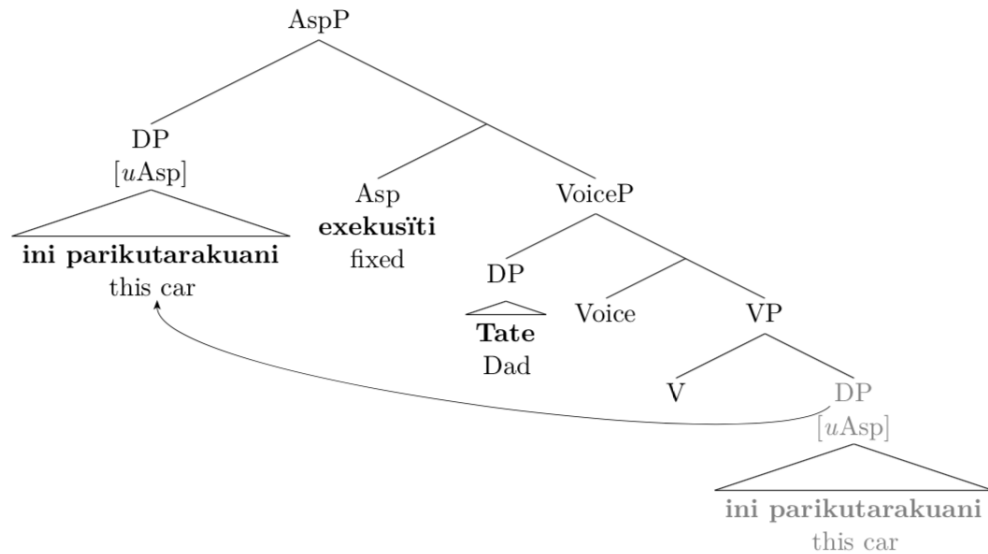

At this point, the object does c-command an element bearing the feature [*Asp*]*—*namely, the *Asp* head. It probes its c-command domain and finds *Asp*, thereby valuing its [*uAsp*] feature:

(57)

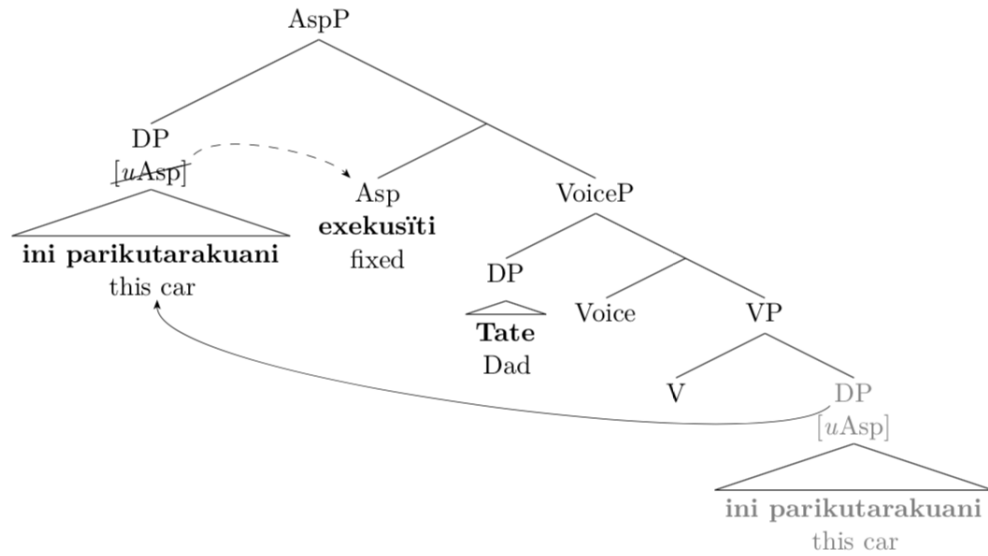

On the Greed analysis, this is all perfectly licit. Therefore, after all the remaining operations have taken place (e.g., the merging in of T, Mood, etc.), the derivation should converge. But this incorrectly predicts that no intervention effects should arise. In (56), the object DP moved to [Spec,AspP] “in search of” a position from which it could value its [uAsp] feature under c-command, thereby crossing the subject DP in [Spec,VoiceP]. The intervention effects discussed in §3.2.1 strongly suggest that this is not in fact possible—i.e., that a DP undergoing A-movement cannot cross another DP on its way to its landing site—but this is incorrectly predicted to be possible on the Greed analysis. On this analysis, the movement of the object in the derivation just discussed is driven entirely by the object’s need to value its [uAsp] feature; there is no reason why greedy movement of this sort should be interfered with by another DP that happens to lie along the movement path. (We are led to this conclusion straightforwardly simply by considering how greedy movement works, on analyses such as Bošković’s 2007 analysis; but the conclusion comes into particularly clear focus once it is recalled that the putative greedy movement in this derivation is driven by a [uAsp] feature, and the subject DP in [Spec,VoiceP] in this derivation does not bear any type of [Asp]-related

feature at all.)

A defender of the Greed analysis might attempt to deal with this incorrect prediction (namely, that profligate subject movement should not display intervention effects) by adding a constraint to the effect that A-movement cannot cross a (filled—i.e., syntactically projected) A-position—or that, more generally, X-movement cannot cross a (filled) X-position, where  $X \in \{A, \bar{A}\}$ . However, this would be a pure stipulation; in particular, it would not follow from the nature of greedy movement at all.

Before this discussion of the Greed-based approach is concluded, an alternative Greed-based analysis should be considered. Is it possible that profligate subject movement is greedy after all, but the feature driving it is a Case feature ( $[u\text{Case}:\square]$ ) rather than features such as  $[u\text{Asp}]$ ,  $[u\text{T}]$ ,  $[u\text{Mood}]$ , and  $[u\text{Pol}]$ ? This alternative would have the considerable advantage of being more principled than the first Greed analysis, since Case features (Vergnaud 1977/2008, a.m.o.) are in one form or another a well-established and independently motivated part of syntactic theory, whereas features such as  $[u\text{Asp}]$ , etc., have much less independent motivation. Unfortunately, a Case-based Greed analysis of profligate subject movement would be highly unmotivated and stipulative for Janitzio P'urhepecha. An initial concern with such an analysis is that profligate subject movement is optional (i.e., the subject can remain in  $[\text{Spec}, \text{VoiceP}]$ ), which sits uneasily with the obligatoriness of Case licensing. Setting that aside, however (after all, it could in principle be that the Case-driven greedy movement can optionally occur covertly), there is a far more serious problem with the Case-based Greed analysis. Although it is plausible that nominative Case is assigned by Mood in Janitzio P'urhepecha (since Mood agrees with the subject—specifically, in Person), there is no evidence whatsoever that Asp, T, or Pol function as Case assigners in this language. In the absence of such evidence, the hypothesis that subject movement to  $[\text{Spec}, \text{AspP}]$ ,  $[\text{Spec}, \text{TP}]$ , and  $[\text{Spec}, \text{PolP}]$  is *Case-driven* greedy movement must be rejected as almost completely unmotivated.



### 3.2.3 Hypothesis C: Profligate subject movement is *Labeling-driven*

Finally, let us consider the possibility that profligate subject movement in Janitzio P’urhepecha is neither altruistic nor greedy, but rather Labeling-driven—i.e., driven indirectly by the Labeling Algorithm proposed by [Chomsky \(2013\)](#) and developed in [Chomsky 2015, a.m.o.](#)

The ideas from the Labeling framework that will be relevant to the following discussion can be summarized very simply. When a head and a phrase (= a non-minimal or non-zero-level constituent) merge, the resulting syntactic object is labeled by the head. When two phrases merge (call them XP and YP for convenience), the resulting syntactic object (call it Z) cannot be labeled, unless one of the phrases moves away (allowing the other to label Z) or XP and YP share a feature in common, in which case the shared feature can label Z. In this framework, it is posited that a great deal of movement is forced indirectly—by the need for every constituent (or every relevant constituent) in the structure to receive a label from the Labeling Algorithm. The interested reader is referred to [Chomsky 2013](#) and [Chomsky 2015](#) for more details.

**Labeling analysis A: Profligate subject movement is driven by a labeling problem within VoiceP** One possible way to account for subject movement in Janitzio P’urhepecha in the Labeling framework would be to posit that Voice in this language optionally bears a feature (call it [F]) that it shares with the subject DP. (Let us posit that DPs in general bear [F] in Janitzio P’urhepecha.) When a Voice head bearing [F] is chosen and merged with its complement (VP), the resulting structure (the traditional “Voice’”) is an {X, YP} structure—in traditional terms, a head-complement structure—and is therefore labeled by the head (Voice). Under standard assumptions, then, this {X, YP} structure (call it  $\alpha$ ) also bears [F]. Next,  $\alpha$  merges with the subject DP:

$$(58) \quad \gamma = \{\beta \text{DP}_{[F]}, \alpha \text{VoiceP}_{[F]}\}$$

(The subscript Greek letters in (58) and similar examples are there for ease of exposition; they have no syntactic reality.) Although this is an  $\{\text{XP}, \text{YP}\}$  structure, it is unproblematic for the Labeling Algorithm:  $\alpha$  and  $\beta$  share a feature, namely  $[F]$ , and therefore this feature can label  $\gamma$ . (If the proposal about labeling by feature sharing in Chomsky 2015 is adopted, the label in this case will be not  $[F]$  but  $\langle F, F \rangle$ . Although it is not clear that the extra structure in the label is needed, the  $\langle F, F \rangle$  notation will be used here for continuity with Chomsky 2015.) Because  $\gamma$  can be labeled straightforwardly, no labeling problem arises. In particular, the subject is not forced to move so that  $\gamma$  can be labeled by  $\alpha$  (and conversely,  $\alpha$  is not forced to move so that  $\gamma$  can be labeled by the subject).

When a Voice head not bearing  $[F]$  is chosen, on the other hand,  $\alpha$  will naturally not bear  $[F]$  either:

$$(59) \quad \gamma = \{\beta \text{DP}_{[F]}, \alpha \text{VoiceP}\}$$

Here,  $\gamma$  is an  $\{\text{XP}, \text{YP}\}$  structure with no feature sharing, and is therefore unlabelable. Assuming that  $\gamma$  has to be labeled, this labeling problem could plausibly serve as the trigger for the movement of the subject to some higher position. (The labeling problem presumably cannot be solved by extrinsically assigning  $[F]$  to  $\alpha$  as a Last Resort repair, enabling labeling by feature sharing, because that would violate the Inclusiveness Condition [Chomsky 1995:225]—and, more importantly, because positing such a repair would add an entirely new operation to the grammar, contra Minimalist goals.)

A question arises at this point as to whether the labeling problem in (58) is always solved by raising the subject or, alternatively, it can equally well be solved by raising  $\alpha$  (cf. Chomsky 2013:44, fn. 36). Although this is partially an empirical question, it will not be investigated here, because there is already good reason to believe that this *particular* Labeling analysis of profligate subject movement in Janitzio P’urhepecha is

on the wrong track.

This is so for at least two reasons. First, the feature [F] that it relies on is entirely ad hoc; it does not at this point seem possible even to venture a plausible guess as to what it may actually be. Secondly, and worse, there is no evidence—morphological or otherwise—that Voice has a different featural composition in clauses in which the subject remains in “[Spec,VoiceP]” than it does in clauses in which the subject raises. (Terms of the form “[Spec,XP]” will be written in scare quotes in discussions of Labeling analyses, since the notion of specifier is not a part of the official Labeling framework as developed thus far; see [Chomsky 2013:43](#), especially [fn. 27](#).) This is a problem because even if [F] could be given substantive content (e.g., if it were shown that Voice does share a particular feature with the subject in some language), there would be no real evidence that [F] was involved in indirectly triggering optional subject movement *in Janitzio P’urhepecha*. We can conclude, then, that the analysis on which profligate subject movement in this language occurs to solve a labeling problem within VoiceP is highly stipulative and lacking in independent motivation, warranting its rejection.

**Labeling analysis B: Profligate subject movement is driven by weak clausal functional heads** It would be premature, however, to conclude at this point that profligate subject movement in Janitzio P’urhepecha cannot possibly be Labeling-driven, because there is at least one conceivable alternative Labeling analysis of the phenomenon. It is to this alternative analysis that we now turn.

[Chomsky \(2015\)](#) proposes a Labeling analysis of subject raising in English. He argues that in English, but not in Italian, T is too “weak” to label its projections (henceforth simply *weak*), and must therefore be reinforced by raising a DP to “[Spec,TP].” On this analysis, when T in English merges with its complement (*v*P or some other clausal projection), the result is an {X, YP} structure, but—atypically—this {X, YP} structure cannot be labeled in the normal way (i.e., by the head X = T), because T is

weak. But when the subject DP raises to “[Spec,TP],” the features shared by the DP and T ( $\phi$ -features) can label the traditional “TP”  $\langle\phi,\phi\rangle$ . (Presumably, “ T’ ” somehow receives the same label.)

In Italian, by contrast, T is strong, so it can label the traditional “ T’ ” on its own; this is a standard case of labeling of an  $\{X, YP\}$  structure by X. According to [Chomsky \(2015\)](#), however, the subject *can* raise to “[Spec,TP]” in Italian; it simply doesn’t have to. When it does, “ T’ ” is labeled by T, as before. Chomsky claims that, when the subject raises to “[Spec,TP]” in Italian, T labels not only “ T’ ” but also the maximal “TP.” However, “TP” is an  $\{XP, YP\}$  structure, so it is presumably labeled  $\langle\phi,\phi\rangle$  under feature sharing, as in English. The fact that the subject can raise to “[Spec,TP]” in Italian even though this is not indirectly forced by the Labeling Algorithm is unproblematic on the assumption, which is common in Labeling analyses, that Merge (including Internal Merge) is free rather than triggered. On free-Merge vs. triggered-Merge (and/or crash-proof) approaches to syntax, see [Boeckx 2010](#) vs. [Stockwell 2016, §3.2.1](#), and [Bošković and Messick to appear](#) and references therein, a.m.o.

Can this analysis of subject raising in English and Italian be extended to profligate subject movement in Janitzio P’urhepecha? To extend it in this way, it would be necessary to posit that, in Janitzio P’urhepecha, Asp, T, Mood, and Pol—in fact, probably all the Asp, T, Mood, and Pol heads in the language—come in two versions in the lexicon, one strong (able to label projections) and one weak (unable to label projections). Let H stand for any of the relevant Asp, T, Mood, and Pol heads. It would further have to be posited that H bears a feature [F] that is also borne by DPs (cf. the role of [F] in the previous Labeling analysis, which was laid out in [§3.2.3](#)). On this analysis, when a weak H is chosen, “HP” will be successfully labeled only if a DP (the subject DP, for now) raises to “[Spec,HP].” The subject and H share a feature—[F]—so “HP” (and presumably also “ H’ ”) can be labeled  $\langle F,F\rangle$  under feature sharing.

If [F] were not posited, then “AspP,” “TP,” and “PolP” (with the subject in “Spec”) would be {XP, YP} structures with no feature sharing, and would therefore be unlabelable. (On “MoodP,” see below.) This would be an undesirable result, since “AspP,” “TP,” and “PolP” are perfectly licit structures in Janitzio P’urhepecha. We will not consider here the possibility that “AspP,” “TP,” and “PolP” are unlabelable {XP, YP} structures that are actually *licitly* left unlabeled: the Labeling theorist who would make such a claim would have to substantiate it with an explicit account of when exactly a syntactic object can licitly be left unlabeled.

Returning to the Labeling analysis under consideration in this section, this analysis, like the one in §3.2.3, faces significant problems. First, it does not seem to be able to account (in a principled way) for the intervention effects observed in profligate subject movement in Janitzio P’urhepecha. If all that is needed to strengthen H for labeling purposes is for an element bearing [F] to raise to “[Spec,HP],” then an object should be able to do that just as well as a subject, particularly in a free-Merge architecture like that adopted in Chomsky 2013 and 2015. In such an architecture, an object DP can simply be internally merged directly into “[Spec,HP]” without the need for a prior probing operation of the sort that was posited in the altruistic analysis (§3.2.1) and, on that analysis, is the source of the intervention effects (because probing is constrained to operate under closest c-command).

Secondly, the assumption that (probably all) Asp, T, Mood, and Pol heads in Janitzio P’urhepecha come in two versions in the lexicon, one strong and one weak, is highly stipulative. Chomsky’s (2015) proposal that T is weak in English but strong in Italian ties this putative difference to the traditional notion of richness of agreement (Rizzi 1982). Whether this will prove tenable is an open question, but at least the analysis ties the putative labeling-strength difference between English and Italian T to something observable. This is not possible in the case of Asp, T, Mood, and Pol in Janitzio P’urhepecha, none of which, as far as is known, have different morphological

realizations in sentences in which the subject has moved to their specifier and sentences in which it has not.

Thirdly, and relatedly, this Labeling analysis faces one of the same major problems as the previous one (in §3.2.3): it relies on an ad hoc feature [F] that is unidentified and lacks any independent motivation, morphological or otherwise. To be fair, Mood (unlike Asp, T, and Pol) is unproblematic in this regard, because Mood in Janitzio P’urhepecha agrees with the subject in person (§2.1). It would therefore be natural to posit that Mood in Janitzio P’urhepecha is always strong, like T in Italian: the subject need not move to “[Spec,MoodP]” (and when it doesn’t, Mood labels “MoodP” on its own), and if the subject does move to “[Spec,MoodP],” Mood labels “Mood’,” and “MoodP” is labeled ⟨Pers,Pers⟩ under feature sharing. Asp, T, and Pol, however, do not show any evidence in Janitzio P’urhepecha of bearing a feature [F] which is shared with the subject (or with DPs generally).

This last problem will be worth briefly recapitulating. “AspP,” “TP,” and “PolP” (with the subject in “Spec”) seem to be unlabelable {XP, YP} structures. The Labeling analysis based on weak clausal functional heads—along, for that matter, with the Labeling analysis based on an unlabelable “VoiceP” (§3.2.3)—is forced to render them labelable by positing covert feature sharing, involving the feature referred to here as [F]. Such a move would surely render Labeling analyses unfalsifiable in general.

The conclusion that emerges from this whole discussion, then, is that profiigate subject movement in Janitzio P’urhepecha can be analyzed in a reasonable and empirically adequate way as *altruistic* movement (though even this analysis involves some stipulations), but *Greed-* and *Labeling-*based analyses of the phenomenon run into severe empirical and/or conceptual problems. This in turn provides a strong argument that *purely* altruistic (target-driven) movement does indeed exist.

## Chapter 4

# Subjecthood and quantifier float

Having reached a reasonably firm understanding of the rich syntax of subjecthood in Janitzio P'urhepecha, we can proceed to investigate the phenomenon of *quantifier float* in the language. As this chapter will make clear, the two phenomena are closely interrelated. When investigated in detail, the facts of quantifier float in Janitzio P'urhepecha provide an important new body of evidence for the results established in Chapter 3. In addition, when combined with the results of Chapter 3, the investigation to be carried out in this chapter provides significant, perhaps decisive, evidence in favor of one of the analyses of quantifier float made available in the current theoretical context—at least for Janitzio P'urhepecha. If the arguments developed in this chapter are sound, and the proposals it makes about the nature and derivation of quantifier float survive skeptical scrutiny, the implications for syntactic theory will, as we will see, be substantial.

### 4.1 Introduction

An interesting and well-known fact about sentences containing a quantified nominal phrase is that, in many languages, they alternate with sentences in which the nominal

phrase seems to have been split in two, and at least one of the resulting parts placed in a different position. For example, in the English sentence (60a), the quantifier *all* immediately precedes and forms a constituent with the nominal phrase *the walruses* (its *associate*); but in (60b), which paraphrases (60a), *all* and *the walruses* not only surface in the opposite order but also do not form a constituent, as shown by the intervening auxiliary.

- (60) a. **All the walruses** are painting murals.  
 b. **The walruses** are **all** painting murals.

Because it seems as though the *all* in (60a) could optionally float off its associate to form (60b), sentences such as (60b) are said to exhibit *quantifier float*.

The alternation exemplified in (60) raises the question of how sentences containing floated and nonfloated quantifiers are derived—that is, what syntactic atoms and operations are responsible for their generation (Maling 1976, Sportiche 1988, Ko 2007, Yatabe 2010, Tescari Neto 2012, 2013, and the references immediately below, a.m.o.).

Two main types of analyses of the alternation have been developed. On *stranding* analyses (Sportiche 1988, Giusti 1990, Koopman & Sportiche 1991:221-222, Shlonsky 1991, Merchant 1996, McCloskey 2000, Bošković 2004, Henry 2012, Ott 2015, Al Khalaf submitted; see also Fitzpatrick 2006), the floated quantifier in a sentence like (60b) actually does form a constituent with its associate at some stages of the derivation, but this constituent is broken up by the movement of the associate out of it, which “strands” the quantifier. On this type of analysis, the structure of (60b), irrelevant details aside, is the following:

- (61) *Quantifier float as stranding*

[The walruses]<sub>1</sub> are [all \_\_\_<sub>1</sub>] painting murals.



(Trace notation is used throughout this chapter, the traces being marked with underscores, for ease of exposition.)

On *adverbial* analyses, on the other hand (Doetjes 1992, Baltin 1995, Torrego 1996, Brisson 1998, Benmamoun 1999, Bobaljik 2003; see also Fitzpatrick 2006), a floated quantifier and its associate do not form a constituent at any stage of the derivation. Rather, floated quantifiers such as *all*, *both*, and *each* are adverbial elements; these are typically analyzed as adjuncts, and specifically as adjuncts to the verb phrase or to some other projection in the clausal spine. On such an analysis, (60b) has a structure along the following general lines (cf. Brisson 1998:211-212, (79)):

(62) *Quantifier float as adverbial adjunction*

[The walruses]<sub>1</sub> are [<sub>vP</sub> all [<sub>vP</sub> \_\_\_<sub>1</sub> painting murals]].

As mentioned, then—and as shown in (61-62)—a floated quantifier and its associate form an underlying constituent on the stranding analysis, but not on the adverbial analysis. (Although each of these is a family of analyses, they will be referred to here as “the” stranding analysis and “the” adverbial analysis for convenience.)

Which of these analyses, or what type of combination of them, should be adopted has been the subject of extensive investigation (see the references cited above), but no fieldwide consensus has emerged. This chapter argues that the facts of quantifier float in Janitzio P’urhepecha strongly support the *stranding* analysis, at least for this language. This result stands as a challenge to adverbial-only analyses, on which quantifier float is universally derived by adjunction of the floating quantifier to some projection in the clausal spine.

The chapter is organized as follows. §4.2 surveys the empirical terrain, determining where quantifiers can and cannot float in Janitzio P’urhepecha. §4.3 shows that there is a virtually perfect correspondence between DP positions and floated quantifier positions in Janitzio P’urhepecha, strongly supporting the stranding analysis for this

language. §4.4 demonstrates that the stranding analysis is further supported by case-matching between floated quantifiers and their associates (cf. Merchant 1996). §4.5 considers some apparent counterevidence: some quantifier float sentences superficially appear to violate the Subject Condition, which seems to support the adverbial analysis. It is argued that this is in fact not a serious problem for the stranding analysis, and that only the latter analysis enables us to make sense of all the data. §4.6 concludes.

## 4.2 Where quantifiers can and can't float

The first step will be to survey the empirical landscape. Which syntactic environments allow quantifier float in Janitzio P'urhepecha, and which ones forbid it?

(Like Bošković 2004 [see his p. 685, fn. 4]), this chapter will largely restrict its attention to the quantifier 'all' [*iamindu(eecha)*]. On which quantifiers can float in Janitzio P'urhepecha, see Appendix B.)

### 4.2.1 Subjects

Quantifier float is possible from subjects. To see this, consider first some sentences in which quantifier float has not taken place. Two such sentences are given below.

(63) *No quantifier float*

- a. **Iamindu uatsapi-cha** ch'ana-xa-Ø-ti=sĩ      juata-rhu.  
 all          child-PL          play-DUR-PRS-IND3=pS hill-LOC  
 'All the kids are playing on the hill.'
- b. **Iamindu uasisi-cha** kara-sin-Ø-di=sĩ      inchatiru-eri.  
 all          bat-PL          fly-HAB-PRS-IND3=pS afternoon-GEN  
 'All bats fly in the afternoon.'

The boldfaced string in each of (63a) and (63b) is the reflex of a nominal phrase consisting of the quantifier *iamindu* 'all', a noun, and the plural morpheme. This morpheme

can appear at the right edge of the entire nominal phrase, as in (63), or both phrase-finally and on the quantifier, in an instance of optional concord:

(64) *No quantifier float; plural concord*

- a. **Iamindu-eecha uatsapi-cha** ch'ana-xa-Ø-ti=sī juata-rhu.  
 all-PL child-PL play-DUR-PRS-IND3=pS hill-LOC  
 'All the kids are playing on the hill.'
- b. ?**Iamindu-eecha uasisi-cha** kara-sin-Ø-di=sī inchatiru-eri.  
 all-PL bat-PL fly-HAB-PRS-IND3=pS afternoon-GEN  
 'All bats fly in the afternoon.'

There is a small amount of variation in the judgments on sentences such as (64a-b), as shown by the diacritics: the same speaker will judge some examples of this form perfect and others a bit marginal. Sentences without concord such as those in (63), on the other hand, are always judged perfect, in my experience.

Now that we have examined some sentences in which quantifier float has not occurred, we can proceed to consider some in which it has. The quantifier and the associate in sentences like (64a-b) can be inverted, producing sentences such as (65a-b). (The sentences in (65) feature a plural morpheme both on the associate and on the quantifier, a fact to which we will return shortly.)

(65) *Short-distance quantifier float*

- a. ?**Uatsapi-cha iamindu-eecha** ch'ana-xa-Ø-ti=sī juata-rhu.  
 child-PL all-PL play-DUR-PRS-IND3=pS hill-LOC  
 'The kids are all playing on the hill.'
- b. **Uasisi-cha iamindu-eecha** kara-sin-Ø-di=sī inchatiru-eri.  
 bat-PL all-PL fly-HAB-PRS-IND3=pS afternoon-GEN  
 'Bats all fly in the afternoon.'

This will be referred to here as “short-distance” quantifier float—a descriptive term meant to convey only that the associate and the floated quantifier are string-adjacent. Like sentences of the type shown in (64), sentences involving short-distance quantifier

float receive somewhat variable acceptability judgments: again, the same speaker will judge some such sentences perfect and others a bit marginal.

Finally, a floated quantifier and its associate can be separated by other material. In the examples in (66), this is the verb.

(66) *Long-distance quantifier float*

- a. **Uatsapi-cha** ch'ana-xa-∅-ti=ksi      **iamindu-eecha** juata-rhu.  
 child-PL      play-DUR-PRS-IND3=pS all-PL      hill-LOC  
 'The kids are all playing on the hill.'
- b. **Uasīsī-cha** kara-sin-∅-di=sī      **iamindu-eecha** inchatiru-eri.  
 bat-PL      fly-HAB-PRS-IND3=pS all-PL      afternoon-GEN  
 'Bats all fly in the afternoon.'

This will be referred to as “long-distance” quantifier float—another purely descriptive term.

In every case of quantifier float examined so far, whether short- or long-distance, a plural morpheme has been present both on the associate and on the floated quantifier. This, it turns out, is obligatory. As shown in (63-64), plural concord is optional when no quantifier float has taken place—i.e., the quantifier may either bear a plural morpheme or not (Q Assoc-PL ~ Q-PL Assoc-PL). But if the plural morpheme is left off a *floated* quantifier, the result is full unacceptability:

(67) *Quantifier float requires plural concord*

- a. \*Uatsapi-cha **iamindu** ch'ana-xa-∅-ti=sī      juata-rhu.  
 child-PL      all      play-DUR-PRS-IND3=pS hill-LOC  
 int. 'The kids are all playing on the hill.'
- b. \*Uatsapi-cha ch'ana-xa-∅-ti=sī      **iamindu** juata-rhu.  
 child-PL      play-DUR-PRS-IND3=pS all      hill-LOC  
 int. 'The kids are all playing on the hill.'

(This is also the case in Hebrew (Shlonsky 1991:160-161). Shlonsky argues that, in Hebrew, a floated quantifier obligatorily bears a clitic agreeing with its associate DP

because the DP moves to the specifier of the quantifier ([Spec,QP]), triggering Spec-head agreement. Bošković (2004) argues that a quantifier cannot be floated in the  $\theta$ -position of the containing nominal [which he calls QP], but only in a derived position, deducing this generalization from independent aspects of the theory. Bošković (2018a) argues that sentences such as (67a-b) are unacceptable because they involve attempted extraction from a moved QP, in violation of the Freezing Principle (Culicover & Wexler 1977, Wexler & Culicover 1980, a.o.), which bans movement out of moved elements. On Bošković’s analysis, this ban is circumvented if the associate to be moved out of QP enters into an agreement [feature-sharing] relation at the edge of QP, hence the well-formedness of (65-66). He deduces both the ban on movement out of moved elements and the status of apparent exceptions to it from independent aspects of the theory, working within the Labeling framework.)

Returning to the empirical survey, it is worth noting that (nominative) pronominal associates of quantifiers have essentially the same distribution as their ordinary nominal counterparts. In (68), which does not involve quantifier float, the associate of the quantifier *iamindu(eecha)* ‘all(-PL)’ is the pronoun *jucha* ‘we’. The quantifier can optionally bear the plural morpheme *-eecha*.

- (68) **Iamindu(-eecha) jucha** nira-si-∅-ka=sī kunguarikua-rhu.  
 all(-PL) we go-PFV-PRS-IND1=pS meeting-LOC  
 ‘All of us went to the meeting.’

When quantifier float does occur, as in (69), the associate *jucha* ‘we’ precedes the floated quantifier *iamindueecha* ‘all.PL’. The associate can either immediately precede the floated quantifier or be separated from it by other material (such as the verb word).

- (69) **Jucha <iamindu-eecha>** nira-si-∅-ka=sī <iamindu-eecha>  
 we <all-PL> go-PFV-PRS-IND1=pS <all-PL>  
 kunguarikua-rhu.  
 meeting-LOC  
 ‘We all went to the meeting.’

A non-nominative independent pronoun must bear a case morpheme and a clitic with matching features. Such pronouns apparently cannot be construed with quantifiers, whether unfloats ((70-71)) or floats ((72)), for reasons currently unclear.

(70) *No quantifier float, no concord*

\*Exe-a-si-Ø-ka            **iamindu cha-n=sini.**  
 see-pO-PFV-PRS-IND1 all            you<sub>PL</sub>-ACC=2pO  
 int. ‘I saw all of you.’

(71) *No quantifier float, full concord*

??Exe-a-si-Ø-ka            **iamindu-eecha-ni cha-n=sini.**  
 see-pO-PFV-PRS-IND1 all-PL-ACC            you<sub>PL</sub>-ACC=2pO  
 int. ‘I saw all of you.’

(72) *Attempted quantifier float*

\*Exe-a-si-Ø-ka            **cha-n=sini iamindu-eecha-ni.**  
 see-pO-PFV-PRS-IND1 you<sub>PL</sub>-ACC=2pO all-PL-ACC  
 int. ‘I saw you all.’

[Comment: “No, [this isn’t good] either; I’d say [(73)].”]

(73) Exe-a-si-Ø-ka=ni            iamindu-eecha-ni.  
 see-pO-PFV-PRS-IND1=1sS all-PL-ACC  
 ‘I saw everyone.’

#### 4.2.2 Nonsubjects

As shown above, Janitzio P’urhepecha allows both short- and long-distance quantifier float from subjects. But the language also has a number of types of nominal phrases that do not allow short-distance quantifier float, though they may allow long-distance quantifier float. One example is direct objects.

**Direct objects** A nominal phrase introduced by *iamindu* ‘all’ can serve as an (accusative) direct object. In this situation too, concord is optional: the phrase-final plural and accusative morphemes may either be copied onto *iamindu* or not, as shown in (74).

(74) *No quantifier float; no (or full) concord*

Pia-a-si-Ø-ka=ni                    **iamindu(-eecha-ni)**    **uaxantsikue-echa-ni.**  
 buy-pO-PFV-PRS-IND1=1sS all(-PL-ACC)                    chair-PL-ACC  
 ‘I bought all the chairs.’

(P’urhepecha has differential object marking (Chamoreau 1999, Vázquez-Rojas Maldonado 2011). In Janitzio P’urhepecha, the direct object in (74) may also surface as *iamindu uaxantsikueecha*, with no plural concord and no overt accusative morphemes.)

If short-distance quantifier float is attempted from such a direct object, the result is fully unacceptable, regardless of how much concord takes place:

(75) *Direct objects forbid short-distance quantifier float, with any amount of concord*

\*Pia-a-si-Ø-ka=ni                    **uaxantsikue-echa-ni**    **iamindu(-eecha(-ni)).**  
 buy-pO-PFV-PRS-IND1=1sS chair-PL-ACC                    all(-PL(-ACC))  
 int. ‘I bought all the chairs.’

In Mexican Spanish, Quantifier-Associate order is the default, and Associate-Quantifier order, though possible, is perceived as marked—but it becomes more natural when the quantifier is stressed. It is therefore worth asking whether (75) improves with stress on the quantifier. The answer is no: *\*Piaasikani uaxantsikueechani IAMINDUEECHANI* is fully unacceptable. In my experience, stressing the quantifier in an unacceptable quantifier float sentence in Janitzio P’urhepecha produces no or at best modest improvement (and never full acceptability).

Long-distance quantifier float, however, is possible from direct objects. When the associate *jiuatsichani* ‘the coyotes’ in (76a) is separated from its quantifier *iamindu(eechani)* ‘all’ by the verb, forming (76b), the result is acceptable.

(76) [Context: I went on a trip to an area where there are a lot of pumas and coyotes.

I didn't see the pumas, but I did see all the coyotes.]

a. *No quantifier float; no (or full) concord*

Ambu exe-a-∅-∅-∅ puki-cha-ni, peru  
 not see-pO-PFV-PRS-IND wildcat-PL-ACC but  
 exe-a-si-∅-ka=ni iamindu(?-eecha-ni) **jiuatsi-cha-ni**.  
 see-pO-PFV-PRS-IND1=1sS all(?-PL-ACC) coyote-PL-ACC  
 'I didn't see the pumas, but I saw all the coyotes.'

b. *The direct object permits long-distance quantifier float*

Ambu exe-a-∅-∅-∅ puki-cha-ni, peru **jiuatsi-cha-ni**  
 not see-pO-PFV-PRS-IND wildcat-PL-ACC but coyote-PL-ACC  
 exe-a-si-∅-ka=ni iamindu-eecha-ni.  
 see-pO-PFV-PRS-IND1=1sS all-PL-ACC  
 'I didn't see the pumas, but the coyotes I saw all of.'

Note that the context given in (76), together with the first conjunct of (76b), strongly suggests that the second conjunct of (76b) is a topic-comment structure, with *jiuatsi-cha-ni* 'the coyotes' a topic standing in contrast to the in-situ phrase *pukichani* 'the pumas' in the first conjunct.

**Indirect objects** Notionally "indirect" objects behave precisely like direct objects with respect to quantifier float: short-distance quantifier float is impossible from these phrases, but long-distance quantifier float is possible.

The impossibility of short-distance quantifier float from an indirect object is unaffected by whether the indirect object precedes or follows the direct object (both orders are licit). In (77a), the direct object *katsikueechani* 'the hats' is followed by the indirect object *iamindu(eechani) achatichani* 'all the men'. String inversion of quantifier and associate is impossible ((77b)).



(77) DO-IO order

- a. *No quantifier float; no (or full) concord*

Intsĩmpe-a-sĩ-Ø-ka=ni                      katsikue-echa-ni **iamindu(-eecha-ni)**  
give.as.gift-pO-PFV-PRS-IND1=1sS hat-PL-ACC      all(-PL-ACC)  
**achati-cha-ni.**  
man<sub>RESP</sub>-PL-ACC  
'I gave the hats to all the men as a gift.'

- b. *The indirect object forbids short-distance quantifier float*

\*Intsĩmpe-a-sĩ-Ø-ka=ni                      katsikue-echa-ni **achati-cha-ni**  
give.as.gift-pO-PFV-PRS-IND1=1sS hat-PL-ACC      man<sub>RESP</sub>-PL-ACC  
**iamindu-eecha-ni.**  
all-PL-ACC  
int. 'I gave the hats to all the men as a gift.'

Matters do not change when we move from DO-IO to IO-DO order. In (78a), the indirect object *iamindu(eechani) achatichani* 'all the men' precedes the direct object *katsikueechani* 'the hats' rather than following it. Again, short-distance quantifier float from the indirect object is impossible ((78b)).

(78) IO-DO order

a. *No quantifier float; no (or full) concord*

Intsĩmpe-a-sĩ-Ø-ka=ni                      **iamindu(-eecha-ni)** **achati-cha-ni**  
give.as.gift-pO-PFV-PRS-IND1=1sS all(-PL-ACC)                      man<sub>RESP</sub>-PL-ACC  
katsikue-echa-ni.  
hat-PL-ACC  
'I gave all the men the hats as a gift.'

b. *The indirect object forbids short-distance quantifier float*

\*Intsĩmpe-a-sĩ-Ø-ka=ni                      **achati-cha-ni** **iamindu-eecha-ni**  
give.as.gift-pO-PFV-PRS-IND1=1sS man<sub>RESP</sub>-PL-ACC all-PL-ACC  
katsikue-echa-ni.  
hat-PL-ACC  
int. 'I gave the men<sub>i</sub> all<sub>i</sub> the hats as a gift', i.e.,  
'I gave all the men the hats as a gift.'

[The judgment is strictly keyed to the interpretation indicated.]

Indirect objects do, however, allow long-distance quantifier float—just like direct objects. When the associate *jorhenguaririchani* 'the students' in (79a) is separated by the verb from its quantifier *iamindu(eechani)* 'all', producing (79b), the result is well formed.

(79) [Context: I'm a student, and I just bought a new book. I took it to school, and I didn't show it to the teachers, but I did show it to all the other students.]

a. *No quantifier float*

Ambu exera-a-Ø-Ø-Ø                      jorhentperi-cha-ni juchiti takukata-ni, peru  
not show-pO-PFV-PRS-IND teacher-PL-ACC my book-ACC but  
exera-a-sĩ-Ø-ka=ni                      **iamindu(-eecha-ni)**  
show-pO-PFV-PRS-IND1=1sS all(-PL-ACC)  
**jorhenguariri-cha-ni.**  
student-PL-ACC

'I didn't show the teachers my book, but I showed it to all the [other] students.'

b. *The indirect object permits long-distance quantifier float*

Ambu exera-a-∅-∅-∅ jorhentperi-cha-ni juchiti takukata-ni, peru  
 not show-pO-PFV-PRS-IND teacher-PL-ACC my book-ACC but  
**jorhenguariri-cha-ni** exera-a-si-∅-ka=ni **iamindu-eecha-ni**.  
 student-PL-ACC show-pO-PFV-PRS-IND1=1sS all-PL-ACC  
 ‘I didn’t show the teachers my book, but the [other] students I showed it to  
 all of.’

In (79b), too, the second conjunct seems to be a topicalization structure, with *jorhenguaririchani* ‘the students’ a topic standing in contrast to the untopicalized phrase *jorhentperichani* ‘the teachers’ in the first conjunct.

The structure of ditransitive clauses and the interactions between this structure and quantifier float are investigated in greater detail in Appendix C.

**Objects of postpositions** Finally, short-distance quantifier float is also impossible from the object of a postposition. In (80a), the quantified nominal *iamindu(eechani) achatichani* ‘all the men’ appears as the object of the postposition *jingoni* ‘with’. If short-distance quantifier float is attempted, the result is unacceptable ((80b)).

(80) [Context: I’m at a party where there are a lot of men and women, and I want to tell my friend that I work with all the men who are there. I say...]

a. *No quantifier float*

Anchikuari-sin-∅-ga=ni **iamindu(-eecha-ni) ahati-cha-ni** jingoni.  
 work-HAB-PRS-IND1=1sS all(-PL-ACC) man<sub>RESP</sub>-PL-ACC with  
 ‘I work with all the men.’

b. *The object of the postposition forbids short-distance quantifier float*

\*Anchikuari-sin-∅-ga=ni **ahati-cha-ni iamindu-eecha-ni** jingoni.  
 work-HAB-PRS-IND1=1sS man<sub>RESP</sub>-PL-ACC all-PL-ACC with  
 int. ‘I work with all the men.’

Objects of postpositions diverge from direct and indirect objects, however, in that they also do not allow long-distance quantifier float. In (81a), *iamindu achatichani* ‘all the men’ again serves as the object of the postposition *jingoni* ‘with’. When long-distance quantifier float is attempted from this nominal, the result is quite degraded ((81b)).

(81) [Context: I’m at a party where there are a lot of men and women, and I want to tell my friend that I don’t know the women, but I work with all the men who are there. I say...]

a. *No quantifier float*

Ambu minariku-a-∅-∅-∅      uariti-cha-ni,      peru  
 not meet-pO-PFV-PRS-IND woman<sub>RESP-PL-ACC</sub> but  
 anchikuari-sin-∅-ga=ni    **iamindu(-eecha-ni)** **achati-cha-ni**    jingoni.  
 work-HAB-PRS-IND1=1sS all(-PL-ACC)      man<sub>RESP-PL-ACC</sub> with  
 ‘I don’t know (lit. ‘haven’t met’) the women, but I work with all the men.’

b. *The object of the postposition forbids long-distance quantifier float*

??Ambu minariku-a-∅-∅-∅      uariti-cha-ni,      peru **achati-cha-ni**  
 not meet-pO-PFV-PRS-IND woman<sub>RESP-PL-ACC</sub> but man<sub>RESP-PL-ACC</sub>  
 anchikuari-sin-∅-ga=ni    **iamindu-eecha-ni** jingoni.  
 work-HAB-PRS-IND1=1sS all-PL-ACC      with  
 int. ‘I don’t know (lit. ‘haven’t met’) the women, but the men I work with  
 all of.’

### 4.2.3 Interim summary

Let us take stock. The generalizations we have just arrived at are the following:

(82) *Quantifier float possibilities in Janitzio P’urhepecha*

- a. Subjects allow both short- and long-distance quantifier float.
- b. Nonsubjects forbid short-distance quantifier float, but may allow long-distance quantifier float.

(It is worth noting that, in the examples examined above of long-distance quantifier float from nonsubjects ((76b) and (79b)), the associate seems to be occupying an  $\bar{A}$ -position—likely [Spec,TopP]; cf. Rizzi 1997, Capistrán 2002—whereas this is not obviously the case in the examples of long-distance quantifier float from subjects ((66a-b)), in which the associate may well be in an A-position on at least one parse.)

With these descriptive generalizations established, we can now begin to determine what light can be shed by the facts of Janitzio P’urhepecha quantifier float on the longstanding stranding-vs.-adjunction question.

### 4.3 Stranding vs. adjunction I: Testing the distributional predictions

As discussed by Bobaljik (2003) and Fitzpatrick (2006), one major difference between the stranding analysis and the adverbial analysis of quantifier float lies in the predictions they make about the *distribution* of floated quantifiers.

On the stranding analysis, a floated quantifier is the surface reflex of a DP that has been evacuated by the corresponding associate. Associate movement is normally an alternative to movement of the containing DP. For example, when the subject base-generated in [Spec,vP] is [DP *all* [DP *the walruses*]], the EPP (however analyzed) can be satisfied by moving to [Spec,TP] either the containing DP (*all the walruses*) or the associate DP inside it (*the walruses*). This optionality yields a clear prediction: if a particular position can host a DP that subsequently moves, it should be possible to fill that position with a DP like *all the walruses* and move only the associate inside this DP, stranding the quantifier. Correspondingly, if a particular position cannot host a DP such as {*all (of) / both (of) / each of*} *the walruses* to begin with, then the stranding analysis predicts that it should not be able to host a floated quantifier either. That is, the distribution of floated quantifiers should precisely track that of the corresponding

containing DPs, all else being equal.

On the adverbial analysis, by contrast, a floated quantifier does not form a constituent with its associate at any stage of the derivation; rather, it is an adverbial element adjoined to some clausal projection. Therefore, this analysis predicts that the distribution of floated quantifiers should *not* track that of ordinary DPs. The distributional predictions of the two analyses are summarized below.

(83) *Distributional predictions*

- a. **Stranding analysis:** Floated quantifiers should appear in DP positions (specifically, positions that DPs can be merged in and then move out of).
- b. **Adverbial analysis:** Floated quantifiers should not appear in DP positions.

As shown in §3.1 and §4.2, Janitzio P’urhepecha has a wide range of DP positions, including a strikingly large array of subject positions, making it possible to test the distributional predictions in (83) extensively and carefully.

#### 4.3.1 Quantifier float in subject positions

[Spec, VoiceP] As shown in §3.1.1, the subject in Janitzio P’urhepecha can surface in [Spec, VoiceP], to the right of VoiceP-adverbials such as *xarhin(t)kueri* ‘early’ ((84a)). This position can also host a subject-associated floated quantifier ((84b)).

- (84) a. Uitsindekua mita⟨a⟩nta-si-Ø-ti=sī                    **xarhintkueri**  
 yesterday    open⟨pO⟩-PFV-PRS-IND3=pS early  
 iamindu uariti-cha    ts’im-eri    meiapekue-echa-ni.  
 all woman<sub>RESP-PL</sub>    they-GEN store-PL-ACC  
 ‘Yesterday all the women opened up their stores early.’                    (= (33))
- b. Uitsindekua uariti-cha    mita⟨a⟩nta-si-Ø-ti=sī                    **xarhintkueri**  
 yesterday    woman<sub>RESP-PL</sub> open⟨pO⟩-PFV-PRS-IND3=pS early  
 iamindu-eecha    ts’im-eri    meiapekue-echa-ni.  
 all-PL                    they-GEN store-PL-ACC  
 ‘Yesterday the women all opened up their stores early.’

[Spec,AspP] The subject can also surface between VoiceP-adverbials like *sesi* ‘well’ and the AspP-adverbial *isku jauembarini* ‘suddenly’—i.e., in [Spec,AspP] (§3.1.2; see (85a) below). This position too can house a floated quantifier ((85b)).

- (85) a. Unta-si-Ø-ti=sī      **isku jauembarini** iamindu iurhitskiri-cha  
 fix-PFV-PRS-IND3=pS suddenly                      all young.woman-PL  
**kanekua sesi** ts'im-eri kojtsitarakue-echa-ni.  
 very well they-GEN table-PL-ACC  
 ‘All the young women suddenly fixed their tables very well.’ (= (34))
- b. Iurhitskiri-cha unta-si-Ø-ti=sī      **isku jauembarini**  
 young.woman-PL fix-PFV-PRS-IND3=pS suddenly  
iamindu-eecha **kanekua sesi** ts'im-eri kojtsitarakue-echa-ni.  
 all-PL very well they-GEN table-PL-ACC  
 ‘The young women suddenly all fixed their tables very well.’

[Spec,TP] The subject can alternatively surface between the AspP-adverbial *isku jauembarini* ‘suddenly’ and the TP-adverbial *jimamberi* ‘then’—i.e., in [Spec,TP] (§3.1.3; see (86a) below). Quantifier float is possible in this position as well, as shown by the reasonably acceptable status of sentences such as (86b).

- (86) a. Sesi=mindu uandanta-ni ia      **jimamberi** iamindu uatsapi-cha  
 well=very inform-INF already then                      all child-PL  
**isku jauembarini** ue-nta-si-Ø-ti=sī.  
 suddenly go.out-ITER-PFV-PRS-IND3=pS  
 ‘To tell you the truth, then all the kids suddenly went back out.’ (= (35))
- b. ?Sesi=mindu uandanta-ni ia      uatsapi-cha **jimamberi**  
 well=very inform-INF already child-PL then  
iamindu-eecha **isku jauembarini** ue-nta-si-Ø-ti=sī.  
 all-PL suddenly go.out-ITER-PFV-PRS-IND3=pS  
 ‘To tell you the truth, the kids then all suddenly went back out.’

[Spec,MoodP] The subject can also surface between the TP-adverbial *jimamberi* ‘then’ and the PolP-adverbial *sesimindu uandantani ia* ‘honestly’ (§3.1.4; see (87a) below). This was tentatively analyzed in §3.1.4 as indicating that the subject has the

option of occurring in [Spec,MoodP]. Quantifier float is possible in this position too ((87b)).

- (87) a. **Sesi=mindu uandanta-ni ia** iamindu kustati-cha **jimamberi**  
 well=very inform-PL already all musician-PL then  
 erenta-a-∅-ti=sī materu ereta-rhu.  
 live-FUT-PRS-IND3=pS other town-LOC  
 ‘To tell you the truth, all the musicians will (by) then live in another town.’  
 (= (36))
- b. Kustati-cha **sesi=mindu uandanta-ni ia** iamindu-eecha  
 musician-PL well=very inform-INF already all-PL  
**jimamberi** erenta-a-∅-ti=sī materu ereta-rhu.  
 then live-FUT-PRS-IND3=pS other town-LOC  
 ‘The musicians will honestly all (by) then live in another town.’

[Spec,PolP] Finally, the subject can precede the PolP-adverbial *sesimindu uandantani ia* ‘honestly’ (§3.1.5; see (88a)), which was analyzed in §3.1.5 as indicating that it can occupy an outer specifier of PolP. Quantifier float is possible in this position as well, as demonstrated by the reasonably acceptable status of sentences such as (88b). (In these sentences, the associate is presumably in [Spec,TopP]; cf. Rizzi 1997, Capistrán 2002.)

- (88) a. Iamindu uatsapi-cha **sesi=mindu uandanta-ni ia** sesi  
 all child-PL well=very inform-INF already well  
 t’ire-si-∅-ti=sī.  
 eat-PFV-PRS-IND3=pS  
 ‘All the kids honestly ate well.’ (= (37))
- b. ?Uatsapi-cha iamindu-eecha **sesi=mindu uandanta-ni ia** sesi  
 child-PL all-PL well=very inform-INF already well  
 t’ire-si-∅-ti=sī.  
 eat-PFV-PRS-IND3=pS  
 ‘The kids all honestly ate well.’

If, as suggested by (88), a quantifier can be floated in [Spec,PolP], then a floated quantifier should be able to immediately precede a polarity particle. This prediction is correct,



as shown for *ambu* ‘not’ in (89) and for *k’o* ‘AFFM’ in (90).

- (89) Uatsapi-cha uitsindekua iamindu-eecha **ambu** jikua- $\emptyset$ - $\emptyset$ - $\emptyset$ .  
 boy-PL yesterday all-PL not bathe-PFV-PRS-IND  
 ‘The boys yesterday all didn’t bathe.’
- (90) Iasĩ, uichu-eecha *ambu* ch’ana- $\emptyset$ - $\emptyset$ - $\emptyset$ . Peru misitu-eecha uitsindekua  
 today dog-PL not play-PFV-PRS-IND but cat-PL yesterday  
iamindu-eecha **k’o** ch’ana-sĩ- $\emptyset$ -ti=sĩ.  
 all-PL AFFM play-PFV-PRS-IND3=pS  
 ‘Today, the dogs didn’t play. But the cats yesterday all DID play.’

(In these sentences, the associate of the floated quantifier is presumably in [Spec,TopP] [Rizzi 1997; cf. Capistrán 2002].)

We see, then, that of the five subject positions identified in Janitzio P’urhepecha in §3.1, every single one is also a possible site for a floated quantifier. This type of situation is what is predicted by the stranding analysis of quantifier float, but is quite unexpected on the adverbial analysis.

#### 4.3.2 Quantifier float in nonsubject positions

The distributional predictions of the two analyses can be further tested by determining whether quantifiers can be floated in *nonsubject* DP positions. As shown in (91-92), a direct- or indirect-object-associated quantifier can be floated in the postverbal field, where ordinary direct and indirect objects appear. In each of these examples, a low, VoiceP-adjoined adverbial (*sesi* ‘well’ or *exeparini* ‘carefully’) has been included to ensure that the verb is low, ruling out the possibility that the verb has raised high and the floated quantifier is not in fact in a  $\theta$ -position but rather higher. (See also (76b) and (79b).)

- (91) *A quantifier can be floated in direct object position*

Ambu u⟨a⟩nta-∅-∅-∅ p'orhechi-cha-ni, peru kukuchi-cha-ni **sesi**  
 not fix⟨pO⟩-PFV-PRS-IND pot-PL-ACC but jug-PL-ACC well  
 u⟨a⟩nta-si-∅-ka=ni IAMINDU-EECHA-NI.  
 fix⟨pO⟩-PFV-PRS-IND1=1sS all-PL-ACC  
 ‘I didn’t fix the pots, but the jugs I fixed ALL of well.’

- (92) *A quantifier can be floated in notional indirect object position*

Ambu intsku-a-nta-∅-∅-∅ takukate-echa-ni charaku-eecha-ni, peru  
 not give-pO-ITER-PFV-PRS-IND book-PL-ACC baby-PL-ACC but  
uatsapi-cha-ni **exeparini** intsku-a-nta-si-∅-ka=ni  
 child-PL-ACC carefully give-pO-ITER-PFV-PRS-IND1=1sS  
IAMINDU-EECHA-NI.  
 all-PL-ACC  
 ‘I didn’t give books to the babies, but the kids I carefully gave [books] to ALL of.’

The same test can be run using a passive subject, on the standard assumption that passive subjects are base-generated in object position. As shown in (93, 94), a (nominative) floated quantifier associated with a raised passive subject can indeed surface postverbally. These examples too include a low VoiceP-adjoined adverbial (*sesi* ‘well’ or *eskaparini* ‘carefully’)—to ensure that the verb and the floated quantifier are both low, and the floated quantifier is actually in object position rather than in one of the many subject positions.

- (93) Joskue-echa **sesi** exe-na-sin-∅-di=sī iamindu-eecha  
 star-PL well see-PASS-HAB-PRS-IND3=pS all-PL  
 CHURIKU-ERI.  
 night-GEN  
 ‘The stars can all be seen well at NIGHT.’

- (94) ?P'orhechi-cha **eskaparini** atanta-na-si-∅-ti=sī iamindu-eecha  
 pot-PL carefully paint-PASS-PFV-PRS-IND3=pS all-PL  
 XARHINKUERI.  
 early  
 ‘The pots were all carefully painted {EARLY / in the MORNING}.’

[Spec,FocP] Another position open to DPs that can be used to test the distributional predictions is the left-peripheral focus position, which immediately precedes the focus clitic =*sĩ*. Adapting a proposal of Capistrán’s (2002), =*sĩ* will be analyzed here as a left-peripheral Foc head, and the focused phrase immediately preceding it as sitting in [Spec,FocP] (cf. Rizzi 1997, Servidio 2009, a.o.). Because [Spec,FocP] can host a DP, the stranding analysis predicts that it should be possible to float a quantifier in this position, with its associate occurring even higher (e.g., in [Spec,TopP]; cf. Rizzi 1997, Capistrán 2002). This prediction is correct. In (95), the quantifier *iamindueecha* ‘all.PL’ has been floated in the position immediately preceding =*sĩ*, and its associate (*iurhitskiricha* ‘the young women’) appears to its left, separated from it by the adverbial *uitsindekua* ‘yesterday’.

- (95) Tumbi-cha    ambu arinta-∅-∅-∅    ima-ni    takukata, peru  
 young.man-PL not    read-PFV-PRS-IND that<sub>DIST</sub>-ACC book    but  
 iurhitskiri-cha    uitsindekua    IAMINDU-EECHA =*sĩ* arinta-∅-∅-ti.  
 young.woman-PL yesterday    ALL-PL=FOC    read-PFV-PRS-IND3  
 ‘The young men didn’t read that book, but the young women yesterday ALL  
 read it.’

However, [Spec,FocP] can host both nominals and adverbials (as in Carapan P’urhepecha; see Lizárraga Navarro 2013:245-47). That [Spec,FocP] can host an adverbial in Janitzio P’urhepecha is shown in (96).

- (96) A: ¿Emilia ataranta-sĩn-∅-gi kuruche-echa-ni inchatiru-eri?  
 Emily sell-HAB-PRS-INT fish-PL-ACC    afternoon-GEN  
 ‘Does Emily sell fish in the afternoon?’  
 B: No, XARHINI-RI =*sĩ*.  
 no early.morning-GEN=FOC  
 ‘No, IN THE MORNING.’

Because [Spec,FocP] can host both nominals and adverbials in Janitzio P’urhepecha, sentences such as (95) do not help us choose between the stranding and adverbial analyses.

### 4.3.3 Non-DP positions

Finally, the stranding and adverbial analyses also make different predictions about whether quantifier float should be possible in positions not open to ordinary DPs. On the stranding analysis, if a particular position cannot host a full DP, it should not be able to host a floated quantifier either. On the adverbial analysis, no such correlation is expected; indeed, it should be perfectly possible for a quantifier to float in a position not open to ordinary DPs.

One such position in Janitzio P'urhepecha is to the immediate right of a complement CP, as shown in (97). In (128b), the verb *mite-* ‘know’ takes as its complement a CP headed by the complementizer *eska* ‘that’. The matrix subject *iamindu uatsapicha* ‘all the kids’ is preverbal, and the sentence is perfect. In (97b), the matrix subject appears to the right of the embedded CP, and the result is unacceptable. Finally, (97c) attempts to float the quantifier *iamindueecha* ‘all.PL’ to the right of the embedded CP, with its associate preceding the matrix verb. This too is unacceptable.

- (97) a. *Iamindu uatsapi-cha mite-si-∅-ti=si* [CP *eska tekua ambe*  
 all child-PL know-PFV-PRS-IND3=pS that honey INDEF  
*aspe-j-∅-ka*].  
 be.tasty-HAB-PRS-SJV  
 ‘All kids know that honey is tasty.’
- b. \**Mite-si-∅-ti=si* [CP *eska tekua ambe aspe-j-∅-ka*]  
 know-PFV-PRS-IND3=pS that honey INDEF be.tasty-HAB-PRS-SJV  
*iamindu uatsapi-cha* .  
 all child-PL  
 int. ‘All kids know that honey is tasty.’
- c. \**Uatsapi-cha* *mite-si-∅-ti=si* [CP *eska tekua ambe*  
 child-PL know-PFV-PRS-IND3=pS that honey INDEF  
*aspe-j-∅-ka* *iamindu-eecha*].  
 be.tasty-HAB-PRS-SJV all-PL  
 int. ‘Kids all know that honey is tasty.’

(Admittedly, though, this could have less to do with possible and impossible DP po-

sitions and more to do with a pressure for embedded CPs, which are generally heavy, to appear clause-finally. The proper analysis of the paradigm in (97), then, remains somewhat open.)

Another position that rejects DPs to some extent can be discerned in ditransitive clauses, as shown in (98), though here the judgments are gradient rather than categorical. In (98a), the order of major constituents is Subject  $\gg$  Verb  $\gg$  Direct Object  $\gg$  Indirect Object  $\gg$  Adjunct (the PP *domimbu jimbo* ‘on Sunday’), and the result is perfect. Sentence (98b) attempts to place the subject between the indirect object and the adjunct, producing a clear decrease in acceptability: the result is marginal. Finally, (98c) attempts to float a quantifier in that position (between indirect object and adjunct), with its associate occurring in a preverbal position, and here too the result is marginal rather than fully acceptable.

(98) a. *S-V-DO-IO-Adjunct*

Iamindu uariti-cha      intsĩmpe-sĩ-Ø-ti=sĩ                      ma ch’anarakua  
 all            woman<sub>RESP-PL</sub> give.as.gift-PFV-PRS-IND3=pS a    toy  
**Xumu-ni** domimbu jimbo.  
 Xumu-ACC Sunday    on  
 ‘All the women gave a toy to Xumu as a gift on Sunday.’

b. *?V-DO-IO-S-Adjunct*

?Intsĩmpe-sĩ-Ø-ti=sĩ                      ma ch’anarakua **Xumu-ni**  
 give.as.gift-PFV-PRS-IND3=pS a    toy                      Xumu-ACC  
iamindu uariti-cha domimbu jimbo.  
 all woman<sub>RESP-PL</sub>    Sunday    on  
 int. ‘All the women gave a toy to Xumu as a gift on Sunday.’

c. *?Associate-V-DO-IO-FQ-Adjunct*

?Uariti-cha      intsĩmpe-sĩ-Ø-ti=sĩ                      ma ch’anarakua **Xumu-ni**  
 woman<sub>RESP-PL</sub> give.as.gift-PFV-PRS-IND3=pS a    toy                      Xumu-ACC  
iamindu-eecha domimbu jimbo.  
 all-PL                      Sunday    on  
 int. ‘The women all gave a toy to Xumu as a gift on Sunday.’

Because Janitzio P’urhepecha allows the direct object (here *ma ch’anarakua* ‘a toy’) and the indirect object (here *Xumuni* ‘Xumu.ACC’) to surface in either order, it is worth asking what happens when they are inverted stringwise in (98a-c). The answer is that the judgments remain unchanged, except that the counterpart of (98b) is a bit less marginal (“(?)”), though still dispreferred to the counterpart of (98a):

(99) a. *S-V-IO-DO-Adjunct*

Iamindu uariti-cha      intsimpe-si-Ø-ti=sī                  Xumu-ni    **ma**  
 all                  woman<sub>RESP-PL</sub> give.as.gift-PFV-PRS-IND3=pS Xumu-ACC a  
**ch’anarakua** domimbu jimbo.  
 toy                  Sunday    on  
 ‘All the women gave Xumu a toy as a gift on Sunday.’

b. (?) *V-IO-DO-S-Adjunct*

(?)Intsimpe-si-Ø-ti=sī                  Xumu-ni    **ma ch’anarakua**  
 give.as.gift-PFV-PRS-IND3=pS Xumu-ACC a    toy  
 iamindu uariti-cha    domimbu jimbo.  
 all woman<sub>RESP-PL</sub>    Sunday    on  
 int. ‘All the women gave Xumu a toy as a gift on Sunday.’

c. ?*Associate-V-IO-DO-FQ-Adjunct*

?Uariti-cha      intsimpe-si-Ø-ti=sī                  Xumu-ni    **ma**  
 woman<sub>RESP-PL</sub> give.as.gift-PFV-PRS-IND3=pS Xumu-ACC a  
**ch’anarakua** iamindu-eecha    domimbu jimbo.  
 toy                  all-PL                  Sunday    on  
 int. ‘The women all gave Xumu a toy as a gift on Sunday.’

#### 4.3.4 Interim summary

What this section has shown about the distribution of floated quantifiers in Janitzio P’urhepecha, and how it compares to that of ordinary DPs, is summarized in the following table:

(100) *Acceptability of ordinary DPs and floated quantifiers in various positions*

	Position	Acceptability of DP	Acceptability of FQ
a.	[Spec, VoiceP]	✓ (subject)	✓
b.	[Spec, AspP]	✓ (subject)	✓
c.	[Spec, TP]	✓ (subject)	?
d.	[Spec, MoodP]	✓ (subject)	✓
e.	[Spec, PolP]	✓ (subject)	? (as diagnosed using <i>sesimindu uandantani ia</i> ‘honestly’)
			✓ (as diagnosed using polarity particles)
f.	Direct object position	✓	✓ (DO-associated) ✓ (passive-subject-associated)
g.	Indirect object position	✓	✓
h.	Object-of-P position	✓	?? (see §4.2.2)
i.	[Spec, FocP]	✓	✓
j.	Right of complement CP	*	*
k.	{DO, IO} ___ PP	?	?

The results in (100) show that the distribution of floated quantifiers in Janitzio P’urhepecha tracks that of ordinary DPs extremely closely. Before the implications of this result are discussed, though, the one major discrepancy between the two distributions should be addressed. The object-of-P position can be occupied by a full DP, but not by a floated quantifier. This discrepancy will be analyzed here as having a twofold source. The fact that a quantifier cannot be floated in object-of-P position under “short-distance” quantifier float ((80b)) can be subsumed under a broader generalization: Janitzio P’urhepecha in fact does not allow truly “short-distance” quantifier float at all—like French and unlike Hebrew (Shlonsky 1991).<sup>1</sup> And a quantifier cannot be floated in object-of-P position under “long-distance” quantifier float ((81b)) because

<sup>1</sup>Hence the unacceptability of “short-distance” quantifier float from direct objects ((75)) and notional indirect objects ((77b), (78b)). It appears that, if an associate DP can move to the specifier of its D-quantifier, it must invariably move further. The same is true of nonpronominal associates of quantifiers in English (if quantifier float is derived by stranding in English): compare \**I saw the walruses all* (\*\*of) with *The walruses I saw all of*. This is reminiscent of the fact that, when an English interrogative *wh*-phrase moves to the specifier of a noninterrogative C, it cannot stay there, but must move further (cf. Bošković 2007):

PPs are islands in Janitzio P’urhepecha (see (101, 102)). (Alternatively, or in addition, it might be that this is ruled out by Bošković’s (2004) ban on quantifier float in  $\theta$ -positions, which he deduces from independent aspects of the theory. See Appendix C for some discussion of the extent to which Janitzio P’urhepecha appears to obey this ban.)

(101) a. *A PP can undergo interrogative wh-movement*

$\iota$ Ne-ni jingoni kusta-si- $\emptyset$ -ki Ts’iueriti?  
 who-ACC with play<sub>music</sub>-PFV-PRS-INT Ts’iueriti  
 ‘With whom did Ts’iueriti play (music)?’

b. *The object of a P cannot undergo interrogative wh-movement*

??  $\iota$ Ne-ni kusta-si- $\emptyset$ -ki Ts’iueriti jingoni?  
 who-ACC play<sub>music</sub>-PFV-PRS-INT Ts’iueriti with  
 int. ‘Who did Ts’iueriti play (music) with?’

(102) a. *A PP can undergo interrogative wh-movement*

$\iota$ Ne-ri erachi-ni jingoni kusta-si- $\emptyset$ -ki Ts’iueriti?  
 who-GEN brother-ACC with play<sub>music</sub>-PFV-PRS-INT Ts’iueriti  
 ‘With whose brother did Ts’iueriti play (music)?’

b. *The object of a P does not allow interrogative wh-movement out of it*

\*  $\iota$ Ne-ri kusta-si- $\emptyset$ -ki Ts’iueriti erachi-ni jingoni?  
 who-GEN play<sub>music</sub>-PFV-PRS-INT Ts’iueriti brother-ACC with  
 int.  $\approx$ ‘Who did Ts’iueriti play (music) with the brother of?’

(As pointed out to me by Jorge Hankamer, though, the English translation given for (102b) is also unacceptable—at least for some speakers, including him—even though PPs are not islands in English.)

- 
- (1) a. \*Katie thinks **what** Mike should buy?  
 b. **What** does Katie think (that) Mike should buy?

Because an associate DP in Janitzio P’urhepecha cannot move to the specifier of its D-quantifier and stay there, surface Associate-Quantifier strings in which both parts are nominative ((65a-b)) must be reflexes of nonconstituents. That is, in the relevant sentences, the associate moves string-vacuously out of the DP headed by *iamindueecha* ‘all.PL’ and into a higher subject position.



Returning to (100), the results summarized in this table strongly support the stranding analysis of quantifier float, at least for Janitzio P’urhepecha, and constitute a problem for the adverbial analysis. To see why, consider first the positions in which a quantifier can be floated and then those in which one cannot.

Every position in (100) that can host a DP (aside from the object-of-P position just discussed) can also host a floated quantifier. On the stranding analysis, this is predicted. Floated quantifiers appear in DP positions in Janitzio P’urhepecha because they *are* DPs—more precisely, DPs that have been evacuated by the associates that were originally inside them. If we wished to adopt the alternative analysis—namely, that floated quantifiers are always adverbials adjoined to some clausal projection—we would be hard pressed to explain why these putative adverbials have the distribution of DPs in Janitzio P’urhepecha, and argument DPs at that.

The distributional matchup between floated quantifiers and ordinary DPs extends from positions in which DPs can appear ((100a-i)) to those in which they cannot appear, or cannot easily appear ((100j-k)). A full subject DP cannot occur to the right of a complement CP, and nor can a subject-oriented floated quantifier ((100j)). On the stranding analysis, the latter fact follows from the former. On the adverbial analysis, the two facts are unrelated. To account for the impossibility of floating a quantifier to the right of a complement CP, it would have to be stipulated that a floated quantifier cannot be linearized to the right of the clausal projection it is adjoined to, but must be linearized to its left instead (unlike other adjuncts, such as *domimbu jimbo* ‘on Sunday’ in (98)).

The facts in ((100k)), if anything, tell even more decisively in favor of the stranding analysis. If an ordinary subject surfaces to the right of the direct and indirect objects but to the left of the clause-final adverbial *domimbu jimbo* ‘on Sunday’, the result is marginal ((98b)). Replacing the ordinary subject with a floated quantifier (with the associate higher up) yields an equally marginal result ((98c)). On the stranding analysis,

this is predicted: the marginal structure in (98b) is also present in (98c). It is not clear how the adverbial analysis could account for this—particularly since, on this analysis, *iamindueecha* ‘all.PL’ would presumably have to be right-adjoined in (98c), contra the conclusion (discussed above) that floated quantifiers cannot be allowed to right-adjoin on the adverbial analysis.

But even if the adverbial analysis could be revised or supplemented to account for the data in (100j-k) without too much stipulation, it would still suffer from a major theoretical problem: it misses the overarching generalization that the distribution of floated quantifiers in Janitzio P’urhepecha tracks that of ordinary DPs in a particularly close and striking way. The positions that allow, forbid, and marginally allow ordinary DPs treat floated quantifiers the same way ((100)). This is unexpected on the adverbial analysis, but is exactly what is predicted by the stranding analysis.

Before concluding this section, it will be worthwhile to note a prediction about quantifier float made by our analysis of Janitzio P’urhepecha clause structure. The analysis predicts that an Associate-Quantifier sequence should be able to surface not only preverbally, as in (89-90), but also postverbally. The reason is that it should be possible to generate a quantified nominal such as  $[_{DP} \textit{iamindu(eecha)} [_{DP} \textit{uatsapicha}]]$  ‘all the kids’ in [Spec, VoiceP]; move the associate DP to one of the higher subject positions; and spell out the finite verb in Mood, yielding Verb-Associate-Quantifier order. (It is assumed here for concreteness that *iamindu(eecha)* ‘all’ is a D, and its associate DP [here *uatsapicha* ‘(the) children’] is its complement (cf. McCloskey 2000:59, (6)).) This prediction is borne out: such sentences are indeed fully or relatively acceptable, as shown below.

(103) *Verb-Associate-Quantifier order*

- a. Ch'ana-xa-∅-ti=sī      uatsapi-cha iamindu-eecha juata-rhu.  
play-DUR-PRS-IND3=pS child-PL      all-PL      hill-LOC  
'The kids are all playing on the hill.'
- b. ?Kara-xa-∅-ti=sī      jorhengariri-cha iamindu-eecha uerakua.  
write-DUR-PRS-IND3=pS student-PL      all-PL      outside  
'The students are all writing outside.'

#### 4.4 Stranding vs. adjunction II: Testing the case-matching predictions

The stranding and adverbial analyses of quantifier float also potentially make different predictions about what case patterns should be observed in quantifier float structures—and, in particular, whether or not a floated quantifier should match its associate in morphological case (Merchant 1996). The predictions about this that the two analyses make are laid out below.

(104) *Case-matching predictions*

- a. **Stranding analysis:** It should be at least possible, and perhaps obligatory, for a floated quantifier to bear the same case as its associate (because the associate and floated quantifier originate as subconstituents of a single DP and should therefore display concord with one another [in relevant languages]).
- b. **Adverbial analysis:** A floated quantifier is an adverbial element. If adverbials do not generally bear morphological case in a particular language, then floated quantifiers shouldn't either, all else being equal.<sup>2</sup>

---

<sup>2</sup>As a *Natural Language and Linguistic Theory* reviewer points out, Doetjes (1998), defending the adverbial analysis, proposes that the agreement in case and  $\phi$ -features between a floating quantifier and its associate is “a reflex of the binding relation between the FQ and the DP trace” [p. 205; see also her p. 213]. This suggestion is difficult to assess in the absence of a more explicit analysis. See also the discussion of a proposal of Fitzpatrick's (2006) below.

It has already become clear that there is at least some associate–quantifier case-matching in Janitzio P’urhepecha. In every quantifier float sentence examined so far, the associate and floated quantifier have either both borne nominative case or both borne accusative case. A natural question, then, is whether floated quantifiers and their associates share other case values as well. The answer is yes. To see this, consider the verb *uandontskuari-* ‘converse, talk’. This verb can cooccur with a genitive DP. *Uandontskuari-* + DP<sub>[GEN]</sub> means ‘talk about [DP]’, and the genitive DP may well be an internal argument of the verb. In (105), the genitive internal argument of *uandontskuari-* ‘converse’ is associated with a floated quantifier, and this quantifier obligatorily bears genitive case as well. (Using the nominative form IAMINDU-EECHA ‘all-PL’ with a non-nominative associate—i.e., violating the case-matching requirement—produces full unacceptability [“\*”] in (105) and degradation [“?”] in (106–107) below.)

(105) *Genitive case matching*

Ambu uandontskuari-∅-∅-∅=sī uaxastakue-ech-eri, peru **orepati-ch-eri**  
 not converse-PFV-PRS-IND=pS law-PL-GEN but leader-PL-GEN  
 uandontskuari-sī-∅-ka=sī **iamindu-eech-eri.**  
 converse-PFV-PRS-IND1=pS all-PL-GEN  
 ‘We didn’t talk about the laws, but the leaders we talked about ALL of.’

*Uandontskuari-* ‘converse’ can also cooccur with a DP bearing comitative case; *uandontskuari-* + DP<sub>[COM]</sub> means ‘talk with [DP]’. This comitative DP too may well be an internal argument of the verb. In (106), the comitative argument of *uandontskuari-* ‘converse’ is associated with a floated quantifier, and this quantifier obligatorily bears comitative case too.

(106) *Comitative case matching*

Ambu uandontskuari-∅-∅-∅ pireri-cha-nguni, peru **kustati-cha-nguni**  
not converse-PFV-PRS-IND singer-PL-COM but instrumentalist-PL-COM  
uandontskuari-si-∅-ka=ni **iamindu-eecha-nguni**.  
converse-PFV-PRS-IND1=1sS all-PL-COM  
'I didn't talk to the singers, but the instrumentalists I talked to ALL of.'

Finally, a comitative DP can share its case value with a floated quantifier even when it is plausibly an adjunct. In (107), the comitative DPs receive an instrumental interpretation (e.g., 'with pens and pencils'). The comitative nominal *ts'i kantsakateechanguni* 'with these computers' is associated with a floated quantifier, and this quantifier obligatorily bears comitative case as well.

(107) *Comitative case matching*

[Context: a friend and I are in a classroom where there are a lot of computers.  
I say to him about our friend Mariana, who's a writer...]

Mariana ambu kara-j-∅-ki karanaritakue-echa-nguni, peru **ts'i**  
Mariana not write-HAB-PRS-IND writing.implement-PL-COM but these  
**kantsakate-echa-nguni** kara-sin-∅-di **iamindu-eecha-nguni**.  
computer-PL-COM write-HAB-PRS-IND3 all-PL-COM

'Mariana doesn't write with pens and pencils, but these computers she writes  
on [lit. 'with'] ALL of.'

These case-matching effects are unsurprising on the stranding analysis, but somewhat unexpected on the adverbial analysis. If a floated *iamindueecha* 'all.PL' is an adverbial adjoined to some clausal projection, it is not obvious why it should receive genitive or comitative case which is plausibly assigned by the verbal complex ((105-106)), or comitative case borne by an instrumental adjunct DP ((107)). The facts are particularly puzzling given that adverbials do not otherwise bear morphological case at all in Janitzio P'urhepecha.

The case-matching facts might become more tractable for defenders of the adverbial analysis if they adopted [Fitzpatrick’s \(2006\)](#) proposal that, although (some) floated quantifiers have the external distribution of adverbials (i.e., they are adjoined to a clausal projection), they contain within them a null pronominal. Extended to Janitzio P’urhepecha, this proposal entails that the internal structure of a floating *iamindu-eecha* ‘all-PL’ is really [*iamindu-eecha pro*] or [*iamindu pro-eecha*]. [Fitzpatrick \(2006\)](#) argues that the associate of an adverbial floating quantifier is restricted to A-movement and cannot undergo  $\bar{A}$ -movement, because  $\bar{A}$ -movement of the associate across the null pronominal would induce a weak crossover violation. Fitzpatrick’s null-pronominal analysis is lent plausibility by the obligatory presence of an overt clitic pronoun on floated quantifiers in Hebrew and Arabic ([Shlonsky 1991](#), [Benmamoun 1999](#), [Al Khalaf submitted](#)), and perhaps by English structures such as *The wombats were [all of **them**] eating pizza*. (As pointed out to me by Jim McCloskey, though, complex floating quantifiers such as *all of them* do not have exactly the same distribution as simplex ones—e.g., *all*—in all varieties of English; see [Huddleston & Pullum et al. \[CGEL\] 2002:413](#).)

On this analysis, it can be posited that, when a floated quantifier seems to bear morphological case in Janitzio P’urhepecha, the case is not actually borne by an “adverb” but rather by a pronoun within the adverbial expression. But although this is probably an improvement, a question remains as to how the relevant cases can be assigned to two constituents—their ordinary bearer *and* the pronoun inside the complex floating quantifier. In particular, inherent cases assigned by the verbal complex (which the genitive and comitative cases in [\(105, 106\)](#) may well be) are not ordinarily assigned twice.

A *Natural Language and Linguistic Theory* reviewer questions this claim, suggesting that perhaps a Fitzpatrick-style complex floating quantifier with the structure [FQ *pro*] is “some kind of appositive to the associate DP” and noting that, in languages such as Latin, the verbal complex can assign a given inherent case both to a nominal and

to another phrase that is associated with it somehow—e.g., a depictive secondary predicate. This possibility initially seems attractive, because Janitzio P’urhepecha does have depictive secondary predicates that share the case of the nominal they are predicated of.

A possible solution to this “double case assignment” problem faced by the adverbial analysis, then, would be to try to assimilate case-matching under quantifier float to case-matching in secondary predication. It is unlikely that *iamindueecha* ‘all’ is literally a depictive secondary predicate (let alone a resultative one), but perhaps it receives the same morphological case as its associate through a case-sharing mechanism similar to the one operative in secondary predication.

The problem with this solution is that case-matching between associate and floated quantifier is possible in Janitzio P’urhepecha in syntactic environments in which depictive secondary predication is not. It was shown above ((106)) that the comitative DP cooccurring with *uandontskuari-* ‘converse’ can share its case with a floated quantifier associated with it. Apparently, though, it cannot share its case with the would-be depictive predicate *ts’inariricha* ‘awake.PL’ ((108a)). (The intended meaning of (108a) can be paraphrased reasonably well using an adjunct clause instead of a depictive ((108b)), making it unlikely that (108a) is ruled out independently on deep semantic grounds. That *ts’inariri* ‘awake’ can indeed be used as a depictive is shown by (109).)

(108) Ambu uandontskuari-∅-∅-∅ pireri-cha-nguni, ka...  
 not converse-PFV-PRS-IND singer-PL-COM and  
 ‘I didn’t talk to the singers, and...’

- a. \***kustati-cha-nguni** uandontskuari-si-∅-ka=ni  
 instrumentalist-PL-COM converse-PFV-PRS-IND1=1sS  
**ts’inariri-cha-nguni.**  
 awake-PL-COM  
 ‘\*...the instrumentalists<sub>i</sub> I talked to awake<sub>i</sub>.’

- b. **kustati-cha-nguni** uandontskuari-si-Ø-ka=ni enga=sii  
 instrumentalist-PL-COM converse-PFV-PRS-IND1=1sS SUB=pS  
 ts'inari-rini ja-Ø-p-ka.  
 wake.up-PTCP.PRS be-PFV-PST-SJV  
 '...the instrumentalists I talked to when they were awake.'

(109) *Control example: ts'inariri 'awake' can be a depictive secondary predicate*

- <sup>M</sup>Elena mentku isi anchikuari-sin-Ø-di TS'INARIRI.  
 Elena always thus work-HAB-PRS-IND3 awake  
 semilit. 'Elena always works AWAKE.'  
 id. 'Elena's always awake when she's working.'

(Sentence (109) is acceptable but marked. It becomes more natural if the depictive is replaced by the present participle *ts'inaririni*; cf. (108b).)

The comitative case borne by instrumental adjunct DPs behaves the same way. These DPs can share their case with a floated quantifier ((107)), but not with the would-be depictive *ambarutantakateecha* 'sharpened.PL' ((110a)). Here too, replacing the depictive with an adjunct clause fixes the problem ((110b)). (That *ambarutanta-kateecha* 'sharpened.PL' can be used as a depictive is shown by (111), in which the depictive displays accusative case-matching.)

- (110) Mariana ambu kara-j-Ø-ki kantsakate-echa-nguni, ka...  
 Mariana not write-HAB-PRS-IND computer-PL-COM and  
 'Mariana doesn't write using computers, and...'
- a. \***karanaritakue-echa-nguni** kara-sin-Ø-di  
 writing.implement-PL-COM write-HAB-PRS-IND3  
**ambarutanta-kate-echa-nguni.**  
 sharpen-PTCP.PASS-PL-COM  
 '\*...with pencils<sub>m</sub> she writes sharpened<sub>m</sub>.'
- b. **karanaritakue-echa-nguni** kara-sin-Ø-di enga=sii  
 writing.implement-PL-COM write-HAB-PRS-IND3 SUB=pS  
 ambarutanta-kate-ech-e-Ø-Ø-ka.  
 sharpen-PTCP.PASS-PL-COP-PFV-PRS-SJV  
 '...with pencils she writes when they're sharpened.'



(111) *Control example: ambarutantakateecha ‘sharpened.PL’ can be a depictive secondary predicate*

A: ʔUra-sin-Ø-gi=ri      tsʔi-ni      karanaritakue-echa-ni      pari kara-ni?  
 use-HAB-PRS-INT=2sS these-ACC writing.implement-PL-ACC for write-INF  
 ‘Do you use these pencils to write with?’

B: Jo, ura-sin-Ø-ga=ni      **ambarutanta-kate-echa-ni.**  
 yes use-HAB-PRS-IND1=1sS sharpen-PTCP.PASS-PL-ACC  
 ‘Yes, I use them sharpened.’

To recapitulate, a floated quantifier in Janitzio P’urhepecha shares the morphological case of its associate. On the stranding analysis, this is unsurprising, and can be analyzed as a reflex of concord between quantifier and associate, which start out as a single DP. On the adverbial analysis, by contrast, this case-matching is unexpected. Even if the morphological case apparently borne by the floated quantifier is analyzed as actually borne by a null pronominal local to the quantifier, a question remains as to how the associate and the null pronominal can bear the same case, since cases cannot normally be assigned twice. It does not seem promising to try to assimilate this instance of case-sharing to that observed in depictive secondary predication, since associate–floated-quantifier case-sharing is possible in Janitzio P’urhepecha in environments in which depictive secondary predication is not. The facts of case-matching under quantifier float, then, provide a second argument in favor of the stranding analysis for Janitzio P’urhepecha.

## 4.5 Stranding vs. adjunction III: Testing the island-sensitivity predictions

A third difference between the stranding and adverbial analyses (also discussed in [Fitzpatrick 2006](#)) has to do with the predictions they make about whether quantifier float should appear to be island-sensitive or -insensitive. To see why, consider the following

sentences:

- (112) a. **Both (of) the presidents** were guilty of stealing raisins.  
b. **The presidents** were **both** guilty of stealing raisins.

On the stranding analysis, the derivation of (112b) involves moving to [Spec,TP] the DP *the presidents*, a constituent of the DP generated in the thematic subject position:

- (113) [DP The presidents]<sub>2</sub> were [DP both \_\_<sub>2</sub>] guilty of stealing raisins.

As pointed out by Fitzpatrick (2006), this seems to pose a problem for the stranding analysis, because the derivation in (113) appears to violate the Subject Condition. It involves extracting a DP from a (larger) subject DP, which is generally unacceptable (though see Chomsky 2008, Jurka 2013, and Bibbs 2018 for relevant discussion):

- (114) \*[DP Which country]<sub>3</sub> were [DP both former presidents of \_\_<sub>3</sub>] guilty of stealing raisins?

On the adverbial analysis, however, the derivation of (112b) does not involve extracting a DP from within a subject DP, because [DP *the presidents*] is never inside any larger DP. *Both* is simply an adverbial adjoined to some clausal projection. Therefore, on the adverbial analysis, the derivation of (112b) proceeds along the lines sketched in (115), incurring no violation of the Subject Condition.

- (115) [The presidents]<sub>2</sub> were [AP both [AP \_\_<sub>2</sub> guilty of stealing raisins]].

On the basis of this and other considerations, Fitzpatrick (2006) argues that floating *all*, *both*, and *each* in English are adverbial adjuncts rather than stranded adnominal elements. At any rate, what is important for present purposes is that the predictions about island-(in)sensitivity made by the stranding and adverbial analyses can be tested in Janitzio P'urhepecha to gain additional insight into which analysis is superior for this language. These predictions are laid out below.

(116) *Island-sensitivity predictions*

- a. **Stranding analysis:** Quantifier float structures should not be able to even *appear* to violate the Subject Condition. They are derived by genuine movement, and must therefore obey all applicable constraints on movement.
- b. **Adverbial analysis:** Quantifier float *should* be able to appear to violate the Subject Condition—but the violations will be illusory, because no extraction from a subject DP is actually involved.

As has already become clear, Janitzio P’urhepecha is like English in this respect: quantifier float from subjects is acceptable in a variety of configurations in this language (§4.2.1, §4.3.1). An example is given in (117).

- (117) 

Uasisi-cha	kara-sin-∅-di=sī	iamindu-eecha	inchatiru-eri.
bat-PL	fly-HAB-PRS-IND3=pS	all-PL	afternoon-GEN

  
'Bats all fly in the afternoon.' (= (66b))

On the stranding analysis, sentences such as (117) would appear to violate the Subject Condition; but an adverbial analysis of these sentences would not have any such problematic implication. This seems like preliminary evidence in favor of the adverbial analysis. But how much weight should be accorded to this evidence depends crucially on whether the Subject Condition is in force in Janitzio P’urhepecha to begin with.

Although the empirical picture is complex (as in English and German; see Chomsky 2008, Jurka 2013, Bibbs 2018), the core cases show that something like the Subject Condition is indeed in force in Janitzio P’urhepecha. To see this, consider first the baseline example in (118), which shows that Janitzio P’urhepecha allows extraction from *object* nominals. In this sentence, the genitive nominal *neri* ‘of whom’ has been extracted from the nominal phrase introduced by *ma* ‘a’.

(118) [Context: I know that the baby is scared of a picture of someone, but I don't know who. I want to know who the picture is of. I ask. . .]<sup>3</sup>

? ¿Ne-ri chere-sin-Ø-gi charaku ma p'itakata?  
 who-GEN be.afraid.of-HAB-PRS-INT baby a picture  
 'Who's the baby scared of a picture of?'

In the same context, the corresponding extraction from a subject is severely degraded. This is shown in (119), which uses the verb *chera-* 'scare', the transitive counterpart of *chere-* 'be afraid of'.

(119) [Context: I know that the baby is scared of a picture of someone, but I don't know who. I want to know who the picture is of. I ask. . .]

?\* ¿Ne-ri chera-sin-Ø-gi ma p'itakata charaku-ni?  
 who-GEN scare-HAB-PRS-INT a picture baby-ACC  
 semilit. '\*Who<sub>4</sub> does [a picture of \_\_<sub>4</sub>] scare the baby?'  
 int. 'Who is such that a picture of them scares the baby?'

Similarly, the following sentence, which also attempts extraction from a subject, is completely unacceptable:

(120) [Context: I know that there's a baby who's scared of a picture, but I don't know whose baby it is. I want to know. I ask. . .]

\* ¿Ne-ri chere-sin-Ø-gi charaku ma p'itakata?  
 who-GEN be.afraid.of-HAB-PRS-INT baby a picture  
 semilit. '\*Who<sub>5</sub> is [the baby of \_\_<sub>5</sub>] scared of a picture?'  
 int. 'Whose baby is scared of a picture?'

The sentence in (120) is in fact string-identical to that given as reasonably acceptable in (118). The difference is that the context provided for (118) forces the extraction-from-

<sup>3</sup>This sentence was in fact judged perfect out of context. It may have been judged a bit marginal in context because, for the consultant who supplied these judgments, it is more natural in this context to use the pied-piping option shown in (1) below.

(1) ¿Ne-ri p'itakata-ni chere-sin-Ø-gi charaku?  
 who-GEN picture-ACC be.afraid.of-HAB-PRS-INT baby  
 'Whose picture is the baby scared of?'

object parse, whereas that provided for (120) is only compatible with the (unavailable) extraction-from-subject parse.

It seems, then, that Janitzio P'urhepecha does indeed have some version of the Subject Condition. This gives rise to a quandary. On the one hand, the distributional and case-matching facts presented above (§§4.3, 4.4) argue convincingly in favor of the stranding analysis for Janitzio P'urhepecha. On the other hand, this analysis entails that a subject-oriented floating quantifier in this language is stranded by the movement of its associate out of a containing subject DP—which would apparently violate the Subject Condition, now known to be active in Janitzio P'urhepecha. This latter consideration seems to tell in favor of the *adverbial* analysis, on which quantifier float does not involve violating the Subject Condition. How can this problem be solved?

If the Subject Condition evidence were interpreted as establishing conclusively that floated quantifiers are adjoined adverbials in Janitzio P'urhepecha, it would be extremely difficult to explain why the distribution of floated quantifiers is essentially identical to that of ordinary DPs in this language (not to mention how case-matching occurs under quantifier float). It will therefore be argued here, instead, that the stranding analysis is superior for Janitzio P'urhepecha (after all, it explains the striking distributional correlation uncovered in §4.3) and that the Subject Condition evidence does not tell as unambiguously in favor of the adverbial analysis as it initially appears to.

The argument from the Subject Condition in favor of the adverbial analysis is the following. On the stranding analysis, a DP consisting of a quantifier and its associate can be broken up by moving the associate out of it regardless of whether the containing DP is an object or a subject. But the *wh*-questions in (118, 120) show that a DP can be extracted from an object *but not from a subject* in Janitzio P'urhepecha. Therefore, the stranding analysis is untenable, and the adverbial analysis—which does not need to posit any Subject Condition-violating movement—is to be preferred.

The force of this argument derives largely from the implicit assumption that the

same category moves in quantifier float and in the *wh*-movement structures investigated above: DP. In other words, a *wh*-phrase such as *neri* ‘who.GEN / of whom’ is a DP just as much as an associate nominal such as *uasīsīcha* ‘the bats’ in (117) is. But this is not particularly obvious. If “nominal” *wh*-phrases turned out to belong to some category other than DP, then the categorial difference between *wh*-phrases and associates of quantifiers would be one that extraction operations could be sensitive to. In particular, it could be that, in Janitzio P’urhepecha, DPs (including associates of quantifiers) can be extracted both from objects and from subjects, whereas *wh*-nominals can be extracted from objects but not from subjects. This would still call for an explanation, but it would be similar to a situation found in English—namely, that extracting a DP from a subject generally produces severely degraded results (for many speakers; the judgments in (121) are mine), but some PPs can be extracted quite unproblematically from subjects that are thematically internal arguments ((122); cf. Chomsky 2008):

- (121) a. \*Who did a biography of appear last month?  
 b. \*Who was a biography of published last month?  
 c. \*Who did a biography of receive several awards last month?
- (122) a. Of whom did a biography appear last month?  
 b. Of whom was a biography published last month?  
 c. <sup>M</sup>Of whom did a biography receive several awards last month?

Suppose that this is on the right track—i.e., that in Janitzio P’urhepecha, associates of quantifiers are DPs, but nominal *wh*-phrases belong to some other category (call it QP, following Cable 2010, for concreteness). If this is so, then that categorial difference should be detectable elsewhere. There is some evidence that this expectation is borne out. Ordinary DPs can be extracted from larger DPs headed by the quantifier *iamindu* ‘all’, yielding quantifier float (on the stranding analysis, of course). But nominal

*wh*-phrases apparently cannot be, judging by examples such as (123-124), which are degraded or unacceptable:

- (123) \* ¿ Naki tumbi-cha      pire-si-∅-ki=sī      iamindu-eecha  
 which young.man-PL sing-PFV-PRS-INT=pS all-PL  
 k'uinchikua-rhu?  
 festival-LOC  
 int. ‘?\*Which young men all sang at the festival?’
- (124) ?? ¿ Naki iajchakue-echa-ni      intsku-a-si-∅-ki=ri  
 which pillow-PL-ACC      give-pO-PFV-PRS-INT=2sS  
iamindu-eecha-ni      Anita-ni?  
 all-PL-ACC      Anita-ACC  
 int. ‘Which pillows did you give all of to Anita?’

This difference between ordinary associates of quantifiers and nominal *wh*-phrases would be mysterious if both types of phrases were DPs, but becomes much more tractable if they belong to different categories (DP and QP respectively). On the latter analysis, it can be posited that the D *iamindu* ‘all’ can optionally bear a  $[*D*]^{EPP}$  feature (which attracts the closest DP in its c-command domain to its specifier, allowing it to escape the *iamindu*-DP phase), but it cannot be endowed with a  $[*Q*]^{EPP}$  feature, and as a result, a QP cannot be extracted from a *iamindu*-DP.

Summarizing, the fact that Subject Condition effects do not show up across the board in natural language, but rather appear and disappear in part as a function of the category of the extracted element ((121-122)), substantially weakens the argument from the Subject Condition that floated quantifiers in Janitzio P’urhepecha must be adverbials.

## 4.6 Conclusion

This chapter has focused in large part on the intricate interactions between two parts of Janitzio P’urhepecha grammar: the remarkably wide array of DP positions (most of

them “subject” positions) and the process of quantifier float. (The sheer number of subject positions in Janitzio P’urhepecha provides yet further support for the “distributed” view of subjecthood which has become standard in generative syntax; see [Koopman and Sportiche 1991](#); [Bobaljik and Jonas 1996](#); [McCloskey 1997](#); [Alexiadou and Anagnostopoulou 1998](#); [Zubizarreta 1998](#), ch. 3; [Goodall 2001](#); [Kiss 2002](#); [Svenonius 2002](#); [Cardinaletti 2004](#); [Cable 2012](#); [Rizzi 2015](#); [Poole 2016](#); [Fong 2017a,b, 2018](#); and [Danckaert to appear, a.m.o.](#)) As shown above, the distribution of floated quantifiers in Janitzio P’urhepecha tracks that of ordinary DPs virtually perfectly: whether an ordinary DP is possible, impossible, or marginal in a given position, a floated quantifier behaves the same way in that position. This correlation is predicted by the stranding analysis, but unexpected on the adverbial analysis. The stranding analysis is further supported over the adverbial analysis for Janitzio P’urhepecha by the facts of case-matching between floated quantifiers and their associates (*cf.* [Merchant 1996](#)).

The characteristics of quantifier float in Janitzio P’urhepecha, then, are best accounted for by the *stranding* analysis ([Sportiche 1988](#), [Giusti 1990](#), [Koopman & Sportiche 1991:221-222](#), [Shlonsky 1991](#), [Merchant 1996](#), [McCloskey 2000](#), [Bošković 2004](#), [Henry 2012](#), [Al Khalaf submitted, a.o.](#)). This conclusion poses a considerable challenge to the frequently defended hypothesis that all floated quantifiers are adverbial elements adjoined to some clausal projection ([Doetjes 1992](#), [Baltin 1995](#), [Torrego 1996](#), [Brisson 1998](#), [Benmamoun 1999](#), [Bobaljik 2003, a.o.](#)).

The conclusion that quantifier float is derived by stranding in Janitzio P’urhepecha is important in ways that go considerably beyond the study of the phenomenon itself, and the accompanying stranding-vs.-adjunction debate. First, as has often been noted, if the stranding analysis is shown to be correct for a particular language, then quantifier float becomes one of the most powerful diagnostics for derivational histories in that language, making it possible to determine fairly straightforwardly (at least some of) the positions that particular nominals have occupied on their way to their surface



positions (cf. [Koopman & Sportiche 1991:222](#)). This is an especially valuable diagnostic to be able to use in languages such as Janitzio P'urhepecha, in which clause structure is highly articulated, and both the subject (§3.1) and the verb word (§2.3) can occupy a strikingly wide range of positions. Languages like Janitzio P'urhepecha exploit, in a particularly dramatic way, possibilities for deriving clause structures which are made available by current syntactic theory. In such shifting syntactic landscapes, reliable diagnostics and positional landmarks are all the more necessary.

Furthermore, the result that at least one language implements quantifier float via stranding—i.e., extraction of one nominal from within another, despite their categorial similarity—should prove key as we continue to sharpen our understanding of the locality conditions governing movement (or Internal Merge, [Chomsky 2004](#)—and/or probing, if the former depends on the latter; cf. [Chomsky 2001](#)).

## Chapter 5

# Hyperraising to object

Classical syntactic theory was designed to ensure that *raising* would be able to proceed out of nonfinite clauses, but not out of finite clauses. It has since become clear, however, that a number of languages in fact allow raising out of finite clauses, otherwise known as *hyperraising*. This chapter argues that Janitzio P’urhepecha allows *hyperraising to object* (cf. Bruening 2002, Tanaka 2002, Halpert & Zeller 2015, Deal 2016, Fong 2017a,b, 2018), and develops an analysis of this phenomenon on which it involves two steps of purely altruistic (target-driven) movement—i.e., movement driven *exclusively* by a featural requirement of an attracting head. Alternative analyses of the phenomenon based on Greed (Chomsky 1995a, Bošković 2007, a.o.) or Labeling (Chomsky 2013, 2015, 2016, a.o.) are considered and shown to face serious problems. Janitzio P’urhepecha hyperraising to object, then, sheds light on the driving force for movement: it provides an argument for *Enlightened Self-Interest* (Lasnik 1995, 2003, a.o.), the hypothesis that movement may be driven by a feature *either* of the moving element *or* (as in this case) of an attracting head. The phenomenon will also be shown to narrow down the space of possibilities for understanding the A/ $\bar{A}$ -distinction, one of the fundamental puzzles in syntax.

As is well known, *raising* in English and other familiar languages can proceed

out of a nonfinite clause, but not out of a finite clause: compare *She<sub>i</sub> seems* [<sub>INF</sub> \_\_\_<sub>i</sub> to be happy] with \**She<sub>k</sub> seems* [<sub>FIN</sub> \_\_\_<sub>k</sub> is happy], and *I believed him<sub>i</sub> incorrectly* [<sub>INF</sub> \_\_\_<sub>i</sub> to be happy] with \**I believed him<sub>k</sub>/he<sub>k</sub> incorrectly* [<sub>FIN</sub> \_\_\_<sub>k</sub> was happy]. Classical syntactic theory was developed in such a way as to ensure this result (see, e.g., the Tensed-S Condition, Chomsky 1973:238). But as empirical investigation has progressed, it has become clear that some languages in fact make use of derivations along the lines of the two just starred (Tanaka 2002, Martins & Nunes 2010, Carstens & Diercks 2013, Halpert & Zeller 2015, Deal 2016, Halpert 2016, 2018, Fong 2017a,b, 2018, Petersen & Terzi to appear, a.m.o.; see also Bruening 2002). On a traditional understanding of the A/ $\bar{A}$ -distinction, this is unexpected: finite clauses should allow  $\bar{A}$ -movement out of them, but not A-movement. But that traditional understanding is being revisited and challenged (Chomsky 2008, Obata & Epstein 2008, Safir 2015, van Urk 2015, Fong 2017b, 2018), and the phenomenon of hyperraising provides one of the several motivations for this rethinking.

Against that background, this chapter argues that Janitzio P’urhepecha permits *hyperraising to object*—i.e., A-raising out of a finite clause which creates an object. It then develops an analysis of this type of raising—and specifically of the syntactic mechanisms that permit hyperraising in this language—and considers the theoretical implications of the phenomenon.

This chapter is organized as follows. §5.1 presents novel data from Janitzio P’urhepecha exemplifying a phenomenon that will provisionally be referred to as “accusative + complementizer” (ACC-C). §5.2 shows that the crucial accusative DP in ACC-C is in the matrix clause and not at the left edge of the embedded clause. §5.3 argues that ACC-C is *hyperraising to object*—i.e., movement—rather than prolepsis. §5.4 considers, and rejects, a third possible analysis of ACC-C, on which it is finite object control. §5.5 presents an explicit analysis of ACC-C in Janitzio P’urhepecha, on which it involves two steps of *purely altruistic* (target-driven) movement. The analysis

has the important consequence that a traditional position-based approach to the A/ $\bar{A}$ -distinction is untenable. §5.6 argues against alternative analyses of the phenomenon on which the movement is greedy or Labeling-driven. §5.7 concludes.

## 5.1 The phenomenon: “accusative + complementizer” (ACC-C)

In Janitzio P’urhepecha, the verb *ueka-* ‘want’ can take as its complement a subjunctive clause with a nominative subject. This is shown in (125), in which the embedding complementizer *eska* ‘that’ is boldfaced and the embedded nominative subject *Xumo* is boxed. (Nominative case is not realized overtly in P’urhepecha. The subjunctive mood is used in many or most types of embedded clauses, at least in the Janitzio variety of the language, and may therefore be essentially a reflex of subordination.)

- (125) Ueka-sin-Ø-di=sī            **eska** Xumo u-a-Ø-ka            ma k’umanchikua.  
 want-HAB-PRS-IND3=pS that Xumo make-FUT-PRS-SJV a house  
 ‘They want Xumo to build a house.’

Some speakers of Janitzio P’urhepecha, however, allow a variant of this kind of structure in which (apparently) the embedded subject surfaces to the left of the embedding C, rather than to its right, and bears accusative case (exponed by the morpheme *-ni*) rather than nominative case:

- (126) “*Accusative + complementizer*”  
 Ueka-sin-Ø-di=sī            Xumu-ni **eska** u-a-Ø-ka            ma  
 want-HAB-PRS-IND3=pS Xumo-ACC that make-FUT-PRS-SJV a  
 k’umanchikua.  
 house  
 ‘They want Xumo to build a house.’

The phenomenon exemplified in (126) will for the time being be referred to pretheoretically as the “accusative + complementizer” phenomenon, or ACC-C.

ACC-C is possible only with certain matrix verbs. Another one besides *ueka*- ‘want’ that allows it is *uetarincha*- ‘need’:

(127) a. ‘Need’ without ACC-C

Uetarincha-sin-Ø-ga=ni **eska** Elena k’uanatsinta-a-Ø-ka Xanich-uo.  
 need-HAB-PRS-IND1=1sS that Elena return-FUT-PRS-SJV Janitzio-RESID  
 ‘I need Elena to return to Janitzio.’

b. ‘Need’ with ACC-C

Uetarincha-sin-Ø-ga=ni Elena-ni **eska** k’uanatsinta-a-Ø-ka  
 need-HAB-PRS-IND1=1sS Elena-ACC that return-FUT-PRS-SJV  
 Xanich-uo.  
 Janitzio-RESID  
 ‘I need Elena to return to Janitzio.’

In addition, some speakers find ACC-C with *mite*- ‘know’ fully or relatively acceptable:

(128) a. ‘Know’ without ACC-C

Mite-si-Ø-ka=ni **eska** Ikinari Xanich-uo  
 know-PFV-PRS-IND1=1sS that Ikinari Janitzio-RESID  
 anapu-e-Ø-Ø-ka.  
 from-COP-PFV-PRS-SJV  
 ‘I know that Ikinari’s from Janitzio.’

b. ‘Know’ with ACC-C

%Mite-si-Ø-ka=ni Ikinari-ni **eska** Xanich-uo  
 know-PFV-PRS-IND1=1sS Ikinari-ACC that Janitzio-RESID  
 anapu-e-Ø-Ø-ka.  
 from-COP-PFV-PRS-SJV  
 semilit. ‘I know Ikinari to be from Janitzio.’  
 [?A, ?B, \*C, \*D, ✓E]

(Bracketed diacritics represent acceptability judgments provided by individual speakers; they accompany sentences for which judgments from multiple speakers are available that display some variation. The subscript capital letters corresponding to individual

speakers are used consistently throughout the chapter; hence every diacritic followed by a subscript B was provided by the same speaker, and likewise for all the other letters.)

Two questions about ACC-C that arise immediately are the following:

(129) Questions about ACC-C in Janitzio P'urhepecha

a. *Position question*

Is the accusative DP in the matrix clause, or at the left edge of the embedded clause (e.g., in [Spec,CP])?

b. *Derivation question*

If the accusative DP is in the matrix, does it get there by movement (hypperraising) or by base-generation (prolepsis)?

Each of these questions will be taken up in turn.

## 5.2 The position question: Is $DP_{ACC}$ in the matrix or in the embedded clause?

One respect in which simple examples of ACC-C underdetermine the analysis of the phenomenon is that it is impossible to tell simply by inspecting such examples which clause the accusative DP is in in surface syntax. The mere fact that the accusative DP (henceforth  $DP_{ACC}$ ) precedes the C in ACC-C does not guarantee that it is in the matrix clause at any stage of the derivation: it could instead be at the left edge of the embedded clause (e.g., in [Spec,CP]). Fortunately, the question can be settled empirically, because the two available hypotheses about the surface position of  $DP_{ACC}$  make different predictions about certain phenomena.

### 5.2.1 Ordering with respect to matrix adverbials

One such phenomenon is the relative order of  $DP_{ACC}$  and matrix adverbials. The predictions of the two hypotheses are laid out below.

(130) *Predictions about matrix adverbials*

- a. **Matrix hypothesis:**  $DP_{ACC}$  may well be able to precede a matrix adverbial that in turn precedes the embedded CP. (Cf. Postal 1974:146-154, Halpert & Zeller 2015:485-486.)
- b. **Embedded hypothesis:**  $DP_{ACC}$  should not be able to precede such a matrix adverbial.

Admittedly, even if  $DP_{ACC}$  is in the matrix, there is no guarantee that it will be separable from the embedded CP by a matrix adverbial: whether or not it will be will depend in part on the exact position of the relevant matrix adverbials. But if  $DP_{ACC}$  is at the left edge of the embedded clause, then it certainly should *not* be separable from the rest of the embedded clause by a matrix adverbial.

The relevant sentences—involving  $DP_{ACC} \gg MATRIX\ ADVERBIAL \gg CP$  order—are judged relatively or even quite acceptable. Two examples follow.

(131) (?)Emilia ueka-sin-Ø-di Xumo-ni **mintsita-ni jingoni** eska  
 Emily want-HAB-PRS-IND3 Xumo-ACC heart-ACC with that  
 jaruata-a-Ø-ka pauani.  
 help-FUT-PRS-SJV tomorrow  
 ‘Emily wants Xumo with all her heart to help her tomorrow.’

(132) ?Axuni ueka-sin-Ø-di Ana-ni **alma-ni jingoni** eska  
 Axuni want-HAB-PRS-IND3 Anna-ACC soul-ACC with that  
 pire-a-Ø-ka pauani.  
 sing-FUT-PRS-SJV tomorrow  
 ‘Axuni wants Anna with all his soul to sing tomorrow.’

If  $DP_{ACC}$  were at the left edge of the embedded clause, and could never be in the matrix, it would be essentially impossible to derive the constituent order observed in (131, 132).

Such sentences therefore provide strong evidence that  $DP_{ACC}$  can occupy a position in the matrix clause.

(The opposite order [ $MATRIX\ ADVERBIAL \gg DP_{ACC} \gg eska...]$  is also possible: the judgments given for (131-132) remain unchanged if the boxed  $DP_{ACC}$  is placed to the immediate right of the boldfaced matrix adverbial. What is important for present purposes, though, is that (131-132) constitute strong evidence that  $DP_{ACC}$  can be in the matrix.)

### 5.2.2 Condition B

The matrix and embedded hypotheses also make different predictions about Condition B effects in ACC-C (given a certain assumption about binding domains, discussed directly below):

(133) *Predictions about Condition B*

- a. **Matrix hypothesis:** If a pronoun,  $DP_{ACC}$  should be unable to corefer with the closest c-commanding subject.
- b. **Embedded hypothesis:** If a pronoun,  $DP_{ACC}$  should be able to corefer with the closest c-commanding subject.

If the position occupied by  $DP_{ACC}$  is at the left edge of the embedded clause, we may expect a pronominal  $DP_{ACC}$  to be able to corefer with the closest c-commanding subject, if the domain (in the extended projection of V) within which pronominals must be free is CP. But if  $DP_{ACC}$  is in the matrix, then a pronominal  $DP_{ACC}$  should be unable to corefer with the closest c-commanding subject, because the two DPs will be in the same minimal CP, inducing a Condition B violation.

In order to test the Condition B predictions in (133), it will be necessary to identify anaphoric expressions that are subject to Condition B in Janitzio P'urhepecha. Independent pronouns such as *ima* 'he/she/it' (also a distal demonstrative, 'that') seem



to fit the bill. In (134), the pronominal object *ima-ni* ‘him/her-ACC’ cannot be interpreted as coreferent with the local subject *Irepani*, suggesting that *ima* ‘he/she/it’ is subject to Condition B.

- (134) **Irepani**<sub>i</sub> kuajpe-si-∅-ti                    **ima-ni**<sub>k/\*i</sub>.  
 Irepan    defend-PFV-PRS-IND3 3-ACC  
 ‘Irepan defended him/her/\*himself.’

The interpretation that (134) lacks, namely ‘Irepan defended himself’, is conveyed by (135), in which the reflexive morpheme *-kuare* appears in the verbal complex:

- (135) **Irepani**<sub>i</sub> kuajpe-**kuare**<sub>i</sub>-si-∅-ti.  
 Irepan    defend-REFL-PFV-PRS-IND3  
 ‘Irepan defended himself.’

*Ima* ‘he/she/it’, then, can be used to test the Condition B predictions in (133). This is done in (136), which uses coordinate structures to avoid possible obviation effects. Sentence (136a) shows that, when ACC-C does not occur, the *ima* ‘(s)he’ in an embedded nominative subject of the form ‘*ima* and X’ can corefer with the matrix subject. When ACC-C does occur, however—as in (136b)—the *ima-ni* ‘3-ACC’ in the accusative coordinate DP cannot corefer with the matrix subject.

- (136) a. *No ACC-C*

**Jimena**<sub>i</sub> ueka-sin-∅-di                    eska **ima**<sub>i</sub> **ka Luisa**  
 Jimena    want-HAB-PRS-IND3 that 3    and Louisa  
 andape-a-∅-ka=sī.  
 win-FUT-PRS-SJV=pS  
 ‘Jimena wants herself and Louisa to win.’

[✓<sub>A</sub>, ✓<sub>B</sub>, ✓<sub>F</sub>, ✓<sub>G</sub>]

b. ACC-C

\***Jimena**<sub>i</sub> ueka-sin-Ø-di      **ima-ni**<sub>i</sub> **ka Luisa-ni** eska  
 Jimena want-HAB-PRS-IND3 3-ACC and Luisa-ACC that  
 andape-a-Ø-ka=sī.  
 win-FUT-PRS-SJV=pS  
 lit. ‘??Jimena<sub>i</sub> wants her<sub>i</sub> and Louisa to win.’  
 [\*<sub>A</sub>, \*<sub>B</sub>, \*<sub>F</sub>, \*<sub>G</sub>]

One more minimal pair, which is precisely analogous to the one in (136), is given below.

- (137) a. **Marta**<sub>i</sub> ueka-sin-Ø-di      eska **ima**<sub>i</sub> **ka Paula** sesi  
 Martha want-HAB-PRS-IND3 that 3 and Paula well  
 ereka-a-Ø-ka=sī.  
 live-FUT-PRS-SJV=pS  
 ‘Martha wants herself and Paula to live well.’
- b. \***Marta**<sub>i</sub> ueka-sin-Ø-di      **ima-ni**<sub>i</sub> **ka Paula-ni** eska sesi  
 Martha want-HAB-PRS-IND3 3-ACC and Paula-ACC that well  
 ereka-a-Ø-ka=sī.  
 live-FUT-PRS-SJV=pS  
 lit. ‘?\*Martha<sub>i</sub> wants her<sub>i</sub> and Paula to live well.’

The problem with (136b) and (137b) is not that a coordinate structure cannot serve as the accusative DP in ACC-C: it can, as shown in (138).

- (138) Ueka-a-sin-Ø-ga=ni      Maria-ni ka Ana-ni      **eska**  
 want-pO-HAB-PRS-IND1=1sS Mary-ACC and Anna-ACC that  
 tsipenta-a-Ø-ka=sī.  
 be.happy-FUT-PRS-SJV=pS  
 ‘I want Mary and Anna to be happy.’

Taking stock, DP<sub>ACC</sub>’s ability to be separated from the embedded CP by a matrix adverbial (§5.2.1) and its inability to corefer with the closest subject c-commanding it (§5.2.2) suggest strongly that it occupies a position in the matrix clause, not a position at the left edge of the embedded clause.

### 5.3 The derivation question: Does $DP_{ACC}$ end up in the matrix by movement or base-generation?

Now that  $DP_{ACC}$  has been shown to be in the matrix, a crucial question that arises is how it gets there. Two possibilities come to mind: either the DP raises from within the embedded clause (the *hyperraising hypothesis*) or it is base-generated in the matrix and anaphorically linked to a *pro* in embedded subject position (the *prolepsis hypothesis*):

(139) *Two possible analyses of ACC-C*

- a. **Hyperraising hypothesis:** The DP raises from within the embedded CP.

...  $\boxed{DP}$  ... [CP ... DP ... ]

- b. **Prolepsis hypothesis:** The DP is base-generated in the matrix and anaphorically linked to a *pro* in embedded subject position.

...  $\boxed{DP}_i$  ... [CP ... *pro*<sub>i</sub> ... ]

(A third possibility—that ACC-C is finite object control—will be considered [and rejected] in §5.4.)

These two hypotheses make different predictions about a range of empirical phenomena—predictions to which we now turn.

#### 5.3.1 Intervention effects

The hyperraising and prolepsis hypotheses make different predictions about whether ACC-C should show intervention effects:

(140) *Predictions about intervention effects*

- a. **Hyperraising hypothesis:** ACC-C should show intervention effects.  $DP_{ACC}$  should correspond to the subject of the embedded clause and not to any lower argument.
- b. **Prolepsis hypothesis:** ACC-C should not show intervention effects.  $DP_{ACC}$  should be able to correspond to DPs within the embedded clause other than the highest subject.

If ACC-C is hyperraising (i.e., A-movement—or, more precisely, if the first step in hyperraising is A-movement), it should show intervention effects, which are a signature of A-movement. The claim that this is so is supported by contrasts such as those in (141)–(142), which show that, in both ordinary subject movement and raising to subject, it must be the highest DP that moves to [Spec,TP], not any lower DP.

(141) *Intervention effects in subject movement*

- a. The preschool<sub>*i*</sub> has long \_\_<sub>*i*</sub> served caviar.
- b. \*Caviar<sub>*k*</sub> has long the preschool served \_\_<sub>*k*</sub>.

(142) *Intervention effects in raising to subject*

- a. The preschool<sub>*i*</sub> seems [\_\_<sub>*i*</sub> to serve caviar].
- b. \*Caviar<sub>*k*</sub> seems [the preschool to serve \_\_<sub>*k*</sub>].

If, by contrast, ACC-C involves prolepsis (i.e., the base-generation of a structure involving an anaphoric link between two DPs), then it should not display intervention effects, any more than English prolepsis structures such as those in (143) do.

(143) *No intervention effects in English prolepsis*

- a. Wayne said about the Doberman<sub>*i*</sub> [that it<sub>*i*</sub> had chased the ballerina].
- b. Wayne said about the Doberman<sub>*i*</sub> [that the ballerina had chased it<sub>*i*</sub>].

It turns out that ACC-C in Janitzio P’urhepecha does show intervention effects. Hence (144a), which does not involve ACC-C, has as its ACC-C counterpart (144b), in which  $DP_{ACC}$  corresponds to the subject of the embedded clause. If an attempt is made to construct a second ACC-C version of (144a) in which  $DP_{ACC}$  corresponds to the *object* of the embedded clause, the result is unacceptable ((144c)).

(144) a. *No ACC-C*

Ueka-sin-Ø-ga=ni [CP **eska** Elena] jananari-a-Ø-ka  
 want-HAB-PRS-IND1=1sS [CP that Elena respect-FUT-PRS-SJV  
 Berta-ni].  
 Bertha-ACC]  
 ‘I want Elena to respect Bertha.’

b. *ACC-C:  $DP_{ACC}$  can correspond to the highest DP in the embedded clause*

Ueka-sin-Ø-ga=ni Elena-ni<sub>i</sub> [CP **eska** \_\_\_<sub>i</sub> jananari-a-Ø-ka  
 want-HAB-PRS-IND1=1sS Elena-ACC<sub>i</sub> [CP that \_\_\_<sub>i</sub> respect-FUT-PRS-SJV  
 Berta-ni].  
 Bertha-ACC]  
 ‘I want Elena to respect Bertha.’

[✓<sub>A</sub>, ✓<sub>I</sub>, ✓<sub>J</sub>]

c. *ACC-C:  $DP_{ACC}$  cannot correspond to a lower DP in the embedded clause*

\*Ueka-sin-Ø-ga=ni Berta-ni<sub>k</sub> [CP **eska** Elena  
 want-HAB-PRS-IND1=1sS Bertha-ACC<sub>k</sub> [CP that Elena  
 jananari-a-Ø-ka \_\_\_<sub>k</sub>].  
 respect-FUT-PRS-SJV \_\_\_<sub>k</sub>]  
 int. ‘I want Elena to respect Bertha.’

A second, analogous paradigm is given in (145). The ACC-C sentence in (145b), in which  $DP_{ACC}$  corresponds to the embedded subject, was judged marginally acceptable by three of four speakers consulted. In this it contrasts sharply with (145c), in

which  $DP_{ACC}$  corresponds to the embedded object: this latter sentence was judged fully unacceptable by all four speakers.

(145) a. *No ACC-C*

Ueka-sin-∅-ga=ni            **eska** Luisa minariku-a-∅-ka Ikinari-ni.  
 want-HAB-PRS-IND1=1sS that Luisa meet-FUT-PRS-SJV Ikinari-ACC  
 ‘I want Luisa to meet Ikinari.’

b. *ACC-C:  $DP_{ACC}$  can correspond to the highest DP in the embedded clause*

?Ueka-sin-∅-ga=ni            Luisa-ni<sub>i</sub> [<sub>CP</sub> **eska**     <sub>i</sub> minariku-a-∅-ka  
 want-HAB-PRS-IND1=1sS Luisa-ACC<sub>i</sub> [<sub>CP</sub> that     <sub>i</sub> meet-FUT-PRS-SJV  
 Ikinari-ni].  
 Ikinari-ACC]  
 ‘I want Luisa to meet Ikinari.’

[?A, ?B, ?F, \*G]

c. *ACC-C:  $DP_{ACC}$  cannot correspond to a lower DP in the embedded clause*

\*Ueka-sin-∅-ga=ni            Ikinari-ni<sub>k</sub> [<sub>CP</sub> **eska** Luisa  
 want-HAB-PRS-IND1=1sS Ikinari-ACC<sub>k</sub> [<sub>CP</sub> that Luisa  
 minariku-a-∅-ka     <sub>k</sub>].  
 meet-FUT-PRS-SJV     <sub>k</sub>]  
 int. ‘I want Luisa to meet Ikinari.’

[\*A, \*B, \*F, \*G]

(The fourth speaker simply does not permit ACC-C; in this respect, his idiolect is like English. That the other three speakers who judged (145b) found it only marginally acceptable is not particularly surprising: ACC-C in Janitzio P’urhepecha is a relatively “peripheral” part of the language, the ordinary and unmarked structure being the one with no ACC-C, exemplified in (145a). ACC-C is somewhat delicate, and even speakers who allow it find some instances of it less than fully acceptable.)

We see, then, that ACC-C does display intervention effects, a hallmark of movement.

### 5.3.2 Interaction with islands

The hyperraising and prolepsis hypotheses also make different predictions about how ACC-C should interact with islands (cf. Bruening 2002, §3.1.4):

(146) *Predictions about islands*

- a. **Hyperraising hypothesis:** ACC-C should obey island constraints.
- b. **Prolepsis hypothesis:** ACC-C should not obey island constraints.

On the hyperraising hypothesis, the relation between  $DP_{ACC}$  and the corresponding position in the embedded clause is a movement relation, and should therefore obey island constraints. On the prolepsis hypothesis, it is an anaphoric relation, and should therefore be island-insensitive.

The relation does indeed obey island constraints, as shown by the paradigm below. In (147a), which does not involve ACC-C, the sole argument of the embedded verb *k'uanatsenta-* ‘return’ is the DP *uariti enga minarikuka juramutini* ‘the woman who knows the president’, which contains a relative clause. This DP shows up as  $DP_{ACC}$  in the ACC-C version of this sentence, (147b) (in which the accusative suffix *-ni* surfaces on the head noun *uariti* ‘woman’). In (147c), an attempt has been made to construct a second ACC-C version of the sentence in which most of the complex DP remains in the embedded clause, but *juramutini* ‘the president (ACC)’ surfaces as the matrix accusative DP. The result is unacceptable, showing that the relation between  $DP_{ACC}$  and the corresponding position in the embedded clause cannot be established across an island boundary (in this case, a relative clause boundary).

(147) a. *No ACC-C*

Ueka-sin-∅-ga=ni            **eska** k'uanatsenta-a-∅-ka uariti            enga  
 want-HAB-PRS-IND1=1sS that return-FUT-PRS-SJV woman<sub>RESP</sub> SUB  
 minariku-∅-∅-ka juramuti-ni.  
 meet-PFV-PRS-SJV president-ACC  
 'I want the woman who knows the president to return.'

b. *ACC-C: DP<sub>ACC</sub> can correspond to the highest DP in the embedded clause*

Ueka-sin-∅-ga=ni            uariti-ni<sub>i</sub>            enga minariku-∅-∅-ka  
 want-HAB-PRS-IND1=1sS woman<sub>RESP-ACC</sub> SUB meet-PFV-PRS-SJV  
 juramuti-ni            **eska** k'uanatsenta-a-∅-ka \_\_\_\_<sub>i</sub>.  
 president-ACC that return-FUT-PRS-SJV  
 'I want the woman who knows the president to return.'

c. *ACC-C: DP<sub>ACC</sub> cannot correspond to a DP inside the relative clause*

\*Ueka-sin-∅-ga=ni            juramuti-ni<sub>k</sub> **eska** k'uanatsenta-a-∅-ka  
 want-HAB-PRS-IND1=1sS president-ACC that return-FUT-PRS-SJV  
 uariti            [RC enga minariku-∅-∅-ka \_\_\_\_<sub>k</sub>].  
 woman<sub>RESP</sub> [RC SUB meet-PFV-PRS-SJV \_\_\_\_<sub>k</sub>]  
 semilit. 'I want the president<sub>k</sub> for the woman who knows ∅<sub>k</sub> to return.'  
 int.            'I want the woman who knows the president to return.'

Similar facts are observed with adjunct islands. The ACC-C-less sentence in (149a) has (for some speakers) the ACC-C alternant in (149b), in which DP<sub>ACC</sub> corresponds to the subject of the embedded clause. Two of the four speakers consulted found this ACC-C sentence marginally acceptable. In (149c), by contrast, DP<sub>ACC</sub> corresponds to the subject of an adjunct clause *inside* the clausal complement to the matrix verb. This sentence is fully unacceptable, demonstrating that the relation between DP<sub>ACC</sub> and the corresponding position in the embedded clause cannot cross the boundary of an adjunct island (of this type, at least).



(148) a. *No ACC-C*

Ueka-sin-Ø-ga=ni            **eska** iamindu-eecha kurandi-a-Ø-ka=sī  
 want-HAB-PRS-IND1=1sS that all-PL            listen-FUT-PRS-SJV=pS  
 enga jorhentperi uanda-na-Ø-ka.  
 SUB teacher talk-DUR-PRS-SJV  
 ‘I want everyone to listen when the teacher’s talking.’

b. *ACC-C: DP<sub>ACC</sub> can correspond to the highest DP in the embedded clause*

%Ueka-sin-Ø-ga=ni            iamindu-eecha-ni<sub>i</sub> **eska** \_\_\_\_<sub>i</sub>  
 want-HAB-PRS-IND1=1sS all-PL-ACC<sub>i</sub>            that \_\_\_\_<sub>i</sub>  
 kurandi-a-Ø-ka=sī            enga jorhentperi uanda-na-Ø-ka.  
 listen-FUT-PRS-SJV=pS SUB teacher talk-DUR-PRS-SJV  
 ‘I want everyone to listen when the teacher’s talking.’

[?A, \*B, ?F, \*G]

c. *ACC-C: DP<sub>ACC</sub> cannot correspond to a DP inside the temporal adjunct clause*

\*Ueka-sin-Ø-ga=ni            jorhentperi-ni<sub>k</sub> **eska** iamindu-eecha  
 want-HAB-PRS-IND1=1sS teacher-ACC<sub>k</sub> that all-PL  
 kurandi-a-Ø-ka=sī            [adjunct enga \_\_\_\_<sub>k</sub> uanda-na-Ø-ka].  
 listen-FUT-PRS-SJV=pS [adjunct SUB \_\_\_\_<sub>k</sub> talk-DUR-PRS-SJV]  
 semilit. ‘\*I want the teacher<sub>i</sub> for everyone to listen when Ø<sub>i</sub> is talking.’  
 int.            ‘I want everyone to listen when the teacher’s talking.’

A second and particularly revealing paradigm involving adjunct islands, this one with the matrix verb *mite-* ‘know’, is given below.

(149) a. *No ACC-C*

Mite-si-Ø-ka=ni            **eska** iamindu-eecha kurandi-j-Ø-ka=sī  
 know-PFV-PRS-IND1=1sS that all-PL            listen-HAB-PRS-SJV=pS  
 [adjunct enga jorhentperi uanda-na-Ø-ka].  
 SUB teacher talk-DUR-PRS-SJV  
 ‘I know that everyone listens when the teacher’s talking.’

- b. ACC-C:  $DP_{ACC}$  can correspond to the highest DP in the embedded clause

?Mite-si-Ø-ka=ni                    iamindu-eecha-ni<sub>i</sub>    **eska**    \_\_\_<sub>i</sub>  
 know-PFV-PRS-IND1=1sS    all-PL-ACC<sub>i</sub>                    that    \_\_\_<sub>i</sub>  
 kurandi-j-Ø-ka=sii                    [adjunct enga jorhentperi uanda-na-Ø-ka].  
 listen-HAB-PRS-SJV=pS                    SUB    teacher                    talk-DUR-PRS-SJV]  
 ‘I know that everyone listens when the teacher’s talking.’

- c. ACC-C:  $DP_{ACC}$  cannot correspond to a DP inside the temporal adjunct clause

\*Mite-si-Ø-ka=ni                    jorhentperi-ni<sub>k</sub>    **eska**    iamindu-eecha  
 know-PFV-PRS-IND1=1sS    teacher-ACC<sub>k</sub>                    that    all-PL  
 kurandi-j-Ø-ka=sii                    [adjunct enga \_\_\_<sub>k</sub> uanda-na-Ø-ka].  
 listen-HAB-PRS-SJV=pS                    SUB    \_\_\_<sub>k</sub>    talk-DUR-PRS-SJV]  
 int. ≈ ‘I know about the teacher<sub>k</sub> that everyone listens when (s)he’s<sub>k</sub>  
 talking.’

Summing up, then, ACC-C does obey island constraints.

### 5.3.3 Escape-hatch blocking

A third phenomenon about which the hyperraising and prolepsis hypotheses make different predictions is *escape-hatch blocking*. The relevant predictions are laid out below.

(150) *Predictions about escape-hatch blocking*

- a. **Hyperraising hypothesis:** In raising into the matrix,  $DP_{ACC}$  should pass through the embedded [Spec,CP], after which we may well expect it to be impossible to extract *another* constituent from the embedded CP.
- b. **Prolepsis hypothesis:** ACC-C should not interfere with extraction from the embedded CP.

If ACC-C is derived by movement, then, in raising into the matrix, the DP that surfaces with accusative case ( $DP_{ACC}$ ) should transit through the specifier of the embedded CP, on the standard assumption that CP is a phase. We may well expect this intermediate movement to [Spec,CP] to block the movement of any other constituents out of the

embedded CP. If ACC-C is prolepsis, on the other hand, the embedded C will not project a specifier in the basic case, and hence extraction from the embedded CP should be perfectly possible (and will create a specifier of CP on the way, as a reflex of intermediate movement).

The prediction made by the hyperraising hypothesis is being informally discussed here in terms of the traditional idea of [Spec,CP] as the CP “escape hatch,” which should be “blocked” by the intermediate copy in this position of the hyperraising DP. However, the prediction is a bit different in Bare Phrase Structure (Chomsky 1995b, Carnie 2000, Hornstein & Nunes 2008, Jayaseelan 2008, a.o.), which is officially adopted here. The Bare Phrase Structure hypothesis rejects, as an undesirable stipulation, the older idea that every head projects a classical  $\bar{X}$ -theoretic template (Chomsky 1970) containing at most one specifier position. Therefore, if ACC-C is hyperraising, but the embedded C happens to be able to bear *two* features with EPP subfeatures, then it should be possible after all to extract from the embedded CP both the hyperraising DP and another constituent. The predictions in (150) are still worth testing, though: if ACC-C is compatible with extraction from the embedded CP, this will not help us choose between the two hypotheses, but if ACC-C *blocks* extraction from the embedded CP, this will constitute evidence for the hyperraising hypothesis, as well as for the conclusion that the embedded C in ACC-C can bear at most one feature with an EPP subfeature.

This, it turns out, is exactly what is observed: ACC-C is incompatible with extraction from the embedded CP. Sentence (151a) shows that, when ACC-C does not occur, the *wh*-phrase *ambe* ‘what’ can be extracted from the complement CP. In (151b), ACC-C does take place, but interrogative *wh*-movement does not. In (151c), both are attempted, and the result is highly degraded. ACC-C apparently cannot cooccur with interrogative *wh*-extraction from the embedded CP.

- (151) a. *No ACC-C; extraction from the embedded CP is licit*

$\underset{?}{j}$ Ambe uetarincha-sin- $\emptyset$ -gi=s $\ddot{i}$  eska Emilia pia-a- $\emptyset$ -ka?  
 what need-HAB-PRS-INT=pS that Emily buy-FUT-PRS-SJV  
 ‘What do they need Emily to buy?’

- b. *ACC-C; no (additional) extraction from the embedded CP*

Uetarincha-sin- $\emptyset$ -di=s $\ddot{i}$  Emilia-ni eska pia-a- $\emptyset$ -ka itsukua.  
 need-HAB-PRS-IND3=pS Emily-ACC that buy-FUT-PRS-SJV milk  
 ‘They need Emily to buy milk.’

- c. *ACC-C blocks extraction from the embedded CP*

??  $\underset{?}{j}$ Ambe uetarincha-sin- $\emptyset$ -gi=s $\ddot{i}$  Emilia-ni eska pia-a- $\emptyset$ -ka?  
 what need-HAB-PRS-INT=pS Emily-ACC that buy-FUT-PRS-SJV  
 int. ‘What do they need Emily to buy?’

One more paradigm of this type is given below. *Ambe* ‘what’ can be extracted from the CP complement of *ueka-* ‘want’ ((152a)), and *ueka-* ‘want’ permits ACC-C in the absence of *wh*-extraction ((152b)), but the combination of ACC-C and *wh*-extraction is overwhelmingly rejected ((152c)).

- (152) a. *No ACC-C; extraction from the embedded CP is licit*

$\underset{?}{j}$ Ambe=ri ueka-sin- $\emptyset$ -gi eska Alicia kusta-a- $\emptyset$ -ka?  
 what=2sS want-HAB-PRS-INT that Alice play<sub>music</sub>-FUT-PRS-SJV  
 ‘What do you want Alice to play?’

- b. *ACC-C; no (additional) extraction from the embedded CP*

?Ueka-sin- $\emptyset$ -ga=ri Alicia-ni eska kusta-a- $\emptyset$ -ka ma  
 want-HAB-PRS-IND2=2sS Alice-ACC that play<sub>music</sub>-FUT-PRS-SJV a  
 pirekua.  
 song  
 ‘You want Alice to play a song.’

c. ACC-C blocks extraction from the embedded CP

?\*  $\dot{\iota}$  Ambe=ri ueka-sin-Ø-gi Alicia-ni eska kusta-a-Ø-ka?  
 what=2sS want-HAB-PRS-INT that Alice play<sub>music</sub>-FUT-PRS-SJV  
 int. ‘What do you want Alice to play?’

[?A, \*B, \*F, \*G, \*H]

ACC-C, then, is incompatible with (further) extraction from the embedded CP.

(As pointed out to me by Amy Rose Deal, though, the embedded CP in German prolepsis structures behaves like a [weak] island [Salzmann to appear]. The data in this subsection could therefore be reconciled with the prolepsis hypothesis by analyzing ACC-C as German- rather than English-style prolepsis. As shown in §§5.3.1-5.3.2, however, there is quite a bit of independent evidence that ACC-C is not prolepsis.)

## 5.4 Could ACC-C be finite object control?

Let us take stock. ACC-C shows intervention effects, is island-sensitive, and blocks extraction (of constituents other than DP<sub>ACC</sub>) from the embedded CP. All of this is predicted if ACC-C is hyperraising,<sup>1</sup> but in every case the opposite is predicted by a prolepsis analysis. The evidence, then, strongly favors the conclusion that ACC-C is *hyperraising*.

There is, however, one more alternative: that ACC-C is *finite object control*.

Let us consider what such an analysis would look like, using (153) as an example.

(153) Ikinari ueka-sin-Ø-di Xumo-ni eska jaruata-a-Ø-ka pauani.  
 Ikinari want-HAB-PRS-IND3 Xumo-ACC that help-FUT-PRS-SJV tomorrow  
 ‘Ikinari wants Xumo to help him tomorrow.’

The finite object control analysis would work as follows. In (153), *Xumo-ni* ‘Xumo-ACC’ does not originate as the subject of the embedded clause, and is not a proleptic object

<sup>1</sup>And, in the case of the third prediction (about extraction), if the embedded C can bear at most one feature with an EPP subfeature (§5.3.3).

(with an interpretation along the lines of ‘with regard to Xumo’ or ‘in connection with Xumo’). Rather, it is a genuine argument of the matrix verb *ueka-* ‘want’. In other words, (153) conveys that Ikinari wants *Xumo* in some sense. The CP *eska jaruataaka pauani* ‘that he help him tomorrow’ is a rationale clause, with an interpretation like ‘in order that he may help him tomorrow’ or ‘for the purpose of his helping him tomorrow’. (Some consideration will be given below to a variant of this analysis on which the CP is not in fact a rationale clause, but rather receives some other type of interpretation.) Although this CP is finite, its subject is PRO, which when controlled (as here) needs its controller to be highly local to it:

(154) ACC-C: *Finite object control analysis*

... V [DP]<sub>i</sub> ... [CP ... PRO<sub>i</sub> ... ]

This finite control analysis deserves careful attention, because it seems to be able to account for all the data argued above to favor the hyperraising analysis over the prolepsis analysis—as follows. First, it accounts for the *intervention effects* because PRO must be the closest subject c-commanded by its controller. Therefore, the controller (DP<sub>ACC</sub>) must “correspond to” (i.e., control) the *subject* of the embedded CP, not any lower DP within this CP. Secondly, the analysis accounts for the *island-sensitivity* of ACC-C because the highly local nature of the controller–PRO relation (which forces PRO to be the closest subject c-commanded by the controller) ensures that no island boundary will be able to separate controller and PRO. Finally, the analysis accounts for the *incompatibility between ACC-C and extraction from the embedded CP* because it posits that the embedded CP is an adjunct (specifically, a rationale clause); if this is so, then it is not particularly surprising that extraction from the embedded CP produces highly degraded results.

But although the finite control analysis seems as promising as the hyperraising analysis in the light of the data considered so far, there are three strands of evidence

that strongly suggest that ACC-C must in fact be *hyperraising* and not finite object control.

#### 5.4.1 DP<sub>ACC</sub> is not an argument of the matrix V

The first piece of evidence is that ACC-C is relatively acceptable even in certain sentences for which the finite control analysis would be implausible, such as the following:

- (155) [Context: Near my house there’s another, old house that blocks my view, and no one lives there.]

?Ueka-sin-Ø-ga=ni            inde-ni k’umanchikua-ni    **eska**  
 want-HAB-PRS-IND1=1sS    that<sub>MED</sub>-ACC house-ACC    that  
 xembanta-na-a-Ø-ka.  
 destroy-PASS-FUT-PRS-SJV  
 ‘I want that house to be destroyed.’

- (156) [Context: In the park there’s an old abandoned car that I think is really ugly.]

?Ueka-sin-Ø-ga=ni            ima-ni parikutarakua-ni    **eska**  
 want-HAB-PRS-IND1=1sS    that<sub>DIST</sub>-ACC car-ACC    that  
 pinande-a-Ø-ka.  
 disappear-FUT-PRS-SJV  
 ‘I want that car to disappear.’

- (157) [Context: There’s a guy who’s kind of a pain, and who makes everyone’s life difficult.]

?Ueka-pirin-Ø-ga=ni            inde-ni tumbi-ni                    **eska**  
 want-COND-PRS-IND1=1sS    that<sub>MED</sub>-ACC young.man-ACC    that  
 motsenta-a-Ø-ka    materu ereta-rhu.  
 move-FUT-PRS-SJV    another town-LOC  
 ‘I’d like for that young man to move to another town.’

In none of these sentences can it be reasonably claimed that DP<sub>ACC</sub> is an argument of *ueka*- ‘want’, as the finite control analysis would have it. The hypothetical utterers of

(155-157) would not respectively want “that house,” “that car,” or “that young man”—quite the opposite. Note in this connection that, in the contexts given for (155-157), the English sentences in (158-160) are completely infelicitous:

(158) [Context: Near my house there’s another, old house that blocks my view, and no one lives there.]

- a. #I want that house in order that it may be destroyed.
- b. #I want that house for the purpose of its being destroyed.

(159) [Context: In the park there’s an old abandoned car that I think is really ugly.]

- a. #I want that car in order that it may disappear.
- b. #I want that car for the purpose of its disappearing.

(160) [Context: There’s a guy who’s kind of a pain, and who makes everyone’s life difficult.]

- a. #I want that young man in order that he may move to another town.
- b. #I want that young man for the purpose of his moving to another town.

The reason for this is clear: in (158), for example, the speaker does not want “that house,” so there can be no question of their wanting it for the purpose specified in the post-object adjunct. The contrast between the total infelicity of these English sentences and the relative acceptability of (155-157) in Janitzio P’urhepecha tells strongly against the hypothesis that ACC-C is finite object control.

There remains a question as to why (155-157) are merely reasonably acceptable and not perfect. One possibility is that, in each of them, the Accusative Nominal + CP string has an alternate parse as a relativization structure: ‘that house that will be destroyed’, ‘that car that will disappear’, ‘that young man who will move to another town’. The likely existence of this parse does not threaten the argument from (155-157) that ACC-C is not finite object control, because the sentences would be infelicitous



on the relativization parse in the contexts given, and therefore a hyperraising parse is required to explain why they are reasonably acceptable. But although (155, 157) should be infelicitous on their relativization parse in the contexts provided, it could be that the existence of this parse adds a layer of complexity to the task of judging them, and it is this that resulted in their being judged less than fully acceptable.

As much as possible, the ACC-C sentences investigated in this chapter use a proper name as  $DP_{ACC}$ , to rule out the (probable) parse on which the embedded CP is a relative clause modifying the accusative nominal.

#### 5.4.2 A negative $DP_{ACC}$ can reconstruct into the embedded clause for scope

The second piece of evidence against the finite control analysis is also semantic in nature, having to do with where a negative  $DP_{ACC}$  can take scope.

If ACC-C is hyperraising, this opens up the possibility that a negative  $DP_{ACC}$ —though in the matrix clause in surface syntax—could take scope in the embedded clause it had raised from. But if ACC-C is finite control, then a negative  $DP_{ACC}$  is generated in the matrix, and therefore should *not* be able to take scope in the embedded clause (where there is a PRO controlled by  $DP_{ACC}$ , but no occurrence of  $DP_{ACC}$  itself). Rather, a negative  $DP_{ACC}$  in a biclausal ACC-C sentence should be forced to take matrix scope.

(On the Movement Theory of Control [MTC, [Hornstein 1999](#), [Nunes 2016](#), a.o.], “PRO” is nothing but a lower copy of its controller, which *moves* from “PRO” position to controller position. Therefore, it might initially appear that, on the MTC, ACC-C could be finite control *via* hyperraising. But this is not so, because a genuine control relation involves more than one  $\theta$ -role [or semantic argument-of relation; cf. [Heim & Kratzer 1998](#), ch. 3], both on the MTC and on other approaches, and it was just shown in §5.4.1 that there are ACC-C sentences in which  $DP_{ACC}$  is clearly an argument only of the embedded predicate and not of the matrix V.)

Returning to the the scope of negative  $DP_{ACC}$ s, it turns out that a negative  $DP_{ACC}$  in ACC-C *can* take scope in the embedded clause, supporting the hyperraising analysis over the finite control analysis. To see this, consider the following:

(161) [Context: In the library there’s a teacher who’s trying to concentrate on her reading, but can’t, because there are people there who are talking and making noise. She says...]

a. *With strong verbal morphology*

(?) None-ni uetarincha-sin-∅-ga=ni **eska** uandana-a-∅-ka.  
 no.one-ACC need-HAB-PRS-IND1=1sS that talk-FUT-PRS-SJV  
 ‘I need [no one to talk].’

b. *With weak verbal morphology*

? None-ni uetarincha-j-∅-ki=ni **eska** uandana-a-∅-ka.  
 no.one-ACC need-HAB-PRS-INT=1sS that talk-FUT-PRS-SJV  
 ‘I need [no one to talk].’

(In (161a), the verbal suffixes are in their usual [“strong”] forms: the habitual aspect morpheme surfaces as *-sin* and the first person indicative mood morpheme as *-ga* [underlyingly /-ka/]. In (161b), the verbal suffixes are in their “weak” forms [as also occurs in the presence of a clausemate *ambu* ‘not’]: habitual aspect surfaces as *-j*, and the mood morpheme surfaces as *-ki*, which normally expones interrogative or “clarificational” mood. On strong and weak morphology in P’urhepecha, see [Wares 1974:99, §3.4.](#))

In these sentences,  $DP_{ACC}$  is *noneni* ‘no one’. (Negative objects, and in fact certain other types of negative nonsubjects, surface in a preverbal position in Janitzio P’urhepecha.) Sentence (161a) is quite decently acceptable, and (161b) is reasonably acceptable, on the intended reading—one on which *none* ‘no one’ takes scope in the embedded clause, below *uetarincha-* ‘need’: ‘I need [there to be no one who talks].’ On the finite control analysis, *noneni* ‘no one’ is generated in the matrix in (161a-b), and

should therefore be forced to take matrix scope, above *uetarincha-* ‘need’—yielding the reading ‘There’s no one who I need to talk’. But this would be an irrelevant and bizarre assertion for the teacher to make in the context given in (161). (The discussion here abstracts away from the fact that, on the finite control analysis, the embedded CP is a rationale clause; the matter will be taken up again in the discussion following (163) below.) It seems, then, that the finite control analysis cannot explain why (161a-b) are as acceptable as they are in the context provided (or the intuition of the consultant who supplied these judgments that (161a-b) are as acceptable as they are *on the reading* ‘I need [no one to talk]’).

Sentences (161a-b) are probably the strongest evidence currently available that a negative DP<sub>ACC</sub> in ACC-C can reconstruct into the embedded clause for scope, because the readings ‘I need [no one to talk]’ and ‘There’s no one who I need to talk’ are so utterly different. But supporting evidence can also be found—from sentences with *ueka-* ‘want’:

(162) a. *With strong verbal morphology*

(?) None-ni ueka-sin-∅-ga=ni                **eska**=rini molestari-a-∅-ka  
no.one-ACC want-HAB-PRS-IND1=1sS that=1sO bother-FUT-PRS-SJV  
pauani.  
tomorrow  
‘I want [no one to bother me tomorrow].’

b. *With weak verbal morphology*

? None-ni ue-j-∅-ki=ni                **eska**=rini molestari-a-∅-ka  
no.one-ACC want-HAB-PRS-INT=1sS that=1sO bother-FUT-PRS-SJV  
pauani.  
tomorrow  
‘I want [no one to bother me tomorrow].’

Sentence (162a) is quite decent, and (162b) is reasonably acceptable, on the reading shown—‘I want [no one to bother me tomorrow]’—in which *none* ‘no one’ takes scope

in the embedded clause, below *ueka-* ‘want’. On the finite control analysis, *noneni* ‘no one’ would have to take matrix scope, yielding the rather strange interpretation ‘There’s no one who I want to bother me tomorrow’.

One final example of a negative DP<sub>ACC</sub> taking scope in the embedded clause is given in (163):

(163) *With strong verbal morphology*

[Context: A teacher has taken the kids in her class to visit a handicrafts workshop, and wants all of them to be careful. She says. . .]

None-ni ueeka-sin-∅-ga=ni      **eska** kaka-ua-∅-ka  
 no.one-ACC want-HAB-PRS-IND1=1sS that break-FUT-PRS-SJV  
 kukuchi-cha-ni.  
 jug-PL-ACC  
 ‘I want [no one to break the jugs].’

This sentence is acceptable on the reading shown, in which *none* ‘no one’ takes scope in the embedded clause, below *ue(e)ka-* ‘want’. On the finite control analysis, *noneni* ‘no one’ would have to take matrix scope, and therefore (163) could only mean ‘There’s no one who I want to break the jugs.’ Again, this would be a strange and irrelevant assertion for the teacher to make in the context given. The finite control analysis, then, cannot account for the felicity of (163) in this context, or for the intuition of the consultant who provided these judgments that it can mean ‘I want [no one to break the jugs].’

Furthermore, as mentioned above, the finite control analysis posits that the embedded CP in ACC-C is a rationale clause. This will only make it even more difficult for defenders of said analysis to account for the data in this section. The finite control analysis, once its rationale-clause component is taken into account, predicts that (161a-b) should in fact have the interpretations of the following English sentences, which are bizarre in the relevant context:

- (164) [Context: In the library there's a teacher who's trying to concentrate on her reading, but can't, because there are people there who are talking and making noise. She says...]
- a. #There's no one I need in order that they may talk.
  - b. #There's no one I need for the purpose of their talking.

In parallel fashion, the finite control analysis predicts that (163) should have the interpretation of the English sentences in (165), which are also ludicrous in the relevant context:

- (165) [Context: A teacher has taken the kids in her class to visit a handicrafts workshop, and wants all of them to be careful. She says...]
- a. #There's no one I want in order that they may break the jugs.
  - b. #There's no one I want for the purpose of their breaking the jugs.

Summing up, then, a negative  $DP_{ACC}$  in ACC-C can take scope in the embedded clause. The hyperraising analysis can account for this straightforwardly, as an instance of scope reconstruction. The finite control analysis, by contrast, cannot account for it (and the rationale-clause component of this analysis only makes things worse).

### 5.4.3 *Eska*-rationale clauses are relatively porous

A third argument against the finite control analysis has to do with the opacity of the embedded CP in ACC-C to extraction (which was shown in (151c) and (152c), repeated below).

- (166) *ACC-C blocks extraction from the embedded CP*

?? *¿Ambe uetarincha-sin-Ø-gi=sï Emilia-ni eska pia-a-Ø-ka?*  
 what need-HAB-PRS-INT=3pS Emily-ACC that buy-FUT-PRS-SJV  
 int. 'What do they need Emily to buy?'

(167) *ACC-C blocks extraction from the embedded CP*

?\*  $\downarrow$ Ambe=ri ueka-sin-Ø-gi Alicia-ni **eska** kusta-a-Ø-ka?  
 what=2sS want-HAB-PRS-INT that Alice play<sub>music</sub>-FUT-PRS-SJV  
 int. ‘What do you want Alice to play?’

[?A, \*B, \*F, \*G, \*H]

On the finite control analysis, attempting to extract *ambe* ‘what’ from the *eska*-CPs in (166-167) yields highly degraded results because these *eska*-CPs are rationale clauses, a type of adjunct, and hence the extractions incur adjunct island violations.

This account of the degradedness of (166-167) initially seems promising, especially because *eska* does seem to be able to introduce rationale clauses (in which function it alternates with the complex element *pariki* ‘for-that’):

(168) Ana k’uanatsenta-si-Ø-ti chen-emb-o {**eska** / pari-ki} amamba  
 Anna return-PFV-PRS-IND3 house-POSS.3-RESID {**that** / for-that} mother  
 intsku-nta-ua-Ø-ka takukate-echa-ni.  
 give-ITER-FUT-PRS-SJV book-PL-ACC  
 ‘Anna went back home so that her mother could give her back her books.’

The problem for the finite control analysis is that clear cases of *eska*-rationale clauses, such as the one in (168), are only modestly resistant to extraction (at least of *ambe* ‘what’):

(169) ?  $\downarrow$ Ambe k’uanatsenta-si-Ø-ki Ana chen-emb-o **eska** amamba  
 what return-PFV-PRS-INT Anna house-POSS.3-RESID that mother  
 intsku-a-Ø-ka?  
 give-FUT-PRS-SJV  
 ‘?What did Anna go back home so that her mother could give her?’

In this, clear *eska*-rationale clauses resemble similar adjuncts in English, from many of which *what* (for example) can be extracted with only a mild, if any, decrease in acceptability:

- (170) a. ?What did Anna go back home [so that her mother could give her]?
- b. (?)What did Anna go back home [in order to get from her mother]?
- c. What did Anna go back home [to get from her mother]?

The relative porosity of clear *eska*-rationale clauses ((169)) casts doubt on the hypothesis that the serious degradedness of (166, 167) is due to their involving extraction from such a clause. That being so, it appears that the finite control analysis no longer has an explanation for the pronounced degradedness of such sentences. The hyperraising analysis, however, still does: on this analysis, extraction from the embedded CP in ACC-C produces highly degraded results because  $DP_{ACC}$  has already been extracted from it, and the embedded C involved can bear at most one feature with an EPP subfeature (or, in more traditional terms, the hyperraising DP blocks the CP escape hatch).

#### 5.4.4 Interim conclusion

Evidence from intervention effects, island effects, and extraction from the embedded CP favors a hyperraising analysis of ACC-C over a prolepsis analysis. Furthermore, evidence from ACC-C sentences in which  $DP_{ACC}$  cannot be an argument of the matrix V, and ACC-C sentences in which a negative  $DP_{ACC}$  reconstructs into the embedded clause for scope—along with evidence concerning the relative porosity of *eska*-rationale clauses—favors a hyperraising analysis over a finite object control analysis.

We can conclude, then, that ACC-C is neither prolepsis nor finite object control but hyperraising. The phenomenon will therefore be referred to throughout the rest of the chapter as *hyperraising to object*.

## 5.5 Analysis

In order to determine what hyperraising to object in Janitzio P'urhepecha reveals about the driving force for movement, it will be necessary to construct an explicit, detailed

analysis of it—which it is this section’s task to provide. The section is divided into three parts. §5.5.1 revises our current understanding of Janitzio P’urhepecha clause structure, showing that there is an extra head position between Voice and V (which is identified there with *v*). §5.5.2 argues that hyperraising to object targets a specifier position of *v*P. §5.5.3 provides an explicit analysis of hyperraising to object, illustrating it with a derivation.

### 5.5.1 Not only Voice and V, but also *v*

Chapter 2 argued that finite clauses in Janitzio P’urhepecha have the following structure:

$$(171) \quad \dots [\text{PolP} \dots [\text{MoodP} \dots [\text{TP} \dots [\text{AspP} \dots [\text{VoiceP} \dots [\text{VP} \text{ V} \dots ]]]]]]$$

(Set aside here is the left periphery. See [Capistrán 2002](#) for a detailed investigation of the left periphery in Lake Pátzcuaro P’urhepecha, of which Janitzio P’urhepecha is a variety.) Let us briefly recapitulate some of the results of the investigation in Chapter 2 (and Chapter 3). The verb word can surface in Voice, Asp, T, or Mood. The subject can appear in [Spec, VoiceP], [Spec, AspP], [Spec, TP], [Spec, MoodP] (this is somewhat tentative), or [Spec, PolP]. Profligate subject movement in Janitzio P’urhepecha is driven by optional [*\*D\**]<sup>EPP</sup> features on clausal functional heads. (A very similar analysis of profligate subject movement is argued for convincingly for Dholuo by [Cable \[2012\]](#).)

Janitzio P’urhepecha has adverbials that are specialized to adjoin to particular projections in the clause structure in (171). For example, *isku jauembarini* ‘suddenly’ adjoins to AspP, whereas manner adverbials adjoin to VoiceP. This analysis predicts that when *isku jauembarini* ‘suddenly’ and a manner adverbial both precede VoiceP-internal material (i.e., are left-adjoined), they should have to appear in that order. The prediction is borne out: *isku jauembarini* » MANNER ADVERBIAL order is perfect, whereas the opposite order is consistently judged degraded in comparison.

There is, then, good evidence that manner adverbials adjoin to VoiceP in



Janitzio P’urhepecha. That being so, everything that has been said so far leads us to expect that if a clause in this language contains a (left-adjoined) manner adverbial, a maximally low (external-argument) subject, and a maximally low verb word, the constituent order should be MANNER ADVERBIAL  $\gg$  SUBJECT  $\gg$  VERB WORD  $\gg$  OTHER VOICEP-INTERNAL MATERIAL:

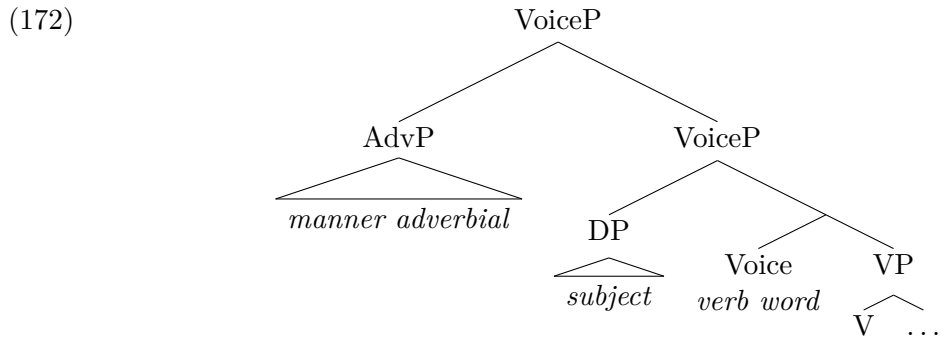

In particular, assuming that external arguments are generated in [Spec, VoiceP] (the standard assumption given the clause structure in (171); cf. Kratzer 1996), it should not be possible to generate the constituent order MANNER ADVERBIAL  $\gg$  VERB WORD  $\gg$  SUBJECT  $\gg$  OTHER VOICEP-INTERNAL MATERIAL. In fact, however, this constituent order is possible. This is shown in (173, 176), in each of which the manner adverbial is boldfaced, the verb word is underlined, and the subject is boxed.

(173) Uitsidekua **xarhintkueri** mitanta-si-Ø-ti=sī iamindu uariti-cha  
 yesterday early open-PFV-PRS-IND3=pS all woman<sub>RESP-PL</sub>  
 ts'im-eri meiapekue-echa-ni.  
 they-GEN store-PL-ACC  
 'Yesterday all the women opened up their stores early.'

(174) Mentku isi **sesi** pire-sin-Ø-di Maria ima-ni pirekua.  
 always thus well sing-HAB-PRS-IND3 Mary that<sub>DIST-ACC</sub> song  
 'Mary always sings that song well.'

(175) Churiku-eri **ikichakueni** isi xosta-si-Ø-ti Axuni japonda-rhu.  
 night-GEN badly thus row-PFV-PRS-IND3 Axuni lake-LOC  
 'At night, Axuni rowed badly on the lake.'

- (176) ?Inchatiru-eri **exeparini** atanta-si-Ø-ti Elena tsintsikate-echa-ni  
 afternoon-GEN carefully paint-PFV-PRS-IND3 Elena wall-PL-ACC  
 k'umanchiku-eri.  
 house-GEN  
 'In the afternoon, Elena carefully painted the walls of the house.'

The fact that this constituent order is possible indicates that the verb word can be realized in a head position higher than the base position of the external argument while still remaining within VoiceP (and hence to the right of left-adjoined VoiceP-adverbials). This can be captured perfectly by positing that external arguments are generated not in [Spec, VoiceP] (as argued in Chapter 2) but in the specifier of a head between Voice and V on the clausal spine—which, following much recent work, will be identified here as *v*.

Hence (175), for example, has the structure in (177). The external argument *Axuni* is generated in [Spec, *v*P]; the verb word is realized in Voice (in this particular sentence); and the manner adverbial *ikichakueni isi* 'badly' is left-adjoined to VoiceP—yielding the constituent order MANNER ADVERBIAL ≫ VERB WORD ≫ SUBJECT ≫ CLAUSE-FINAL ADJUNCT. (This last adjunct is shown right-adjoined to *v*P for concreteness, but little hinges on this here.)

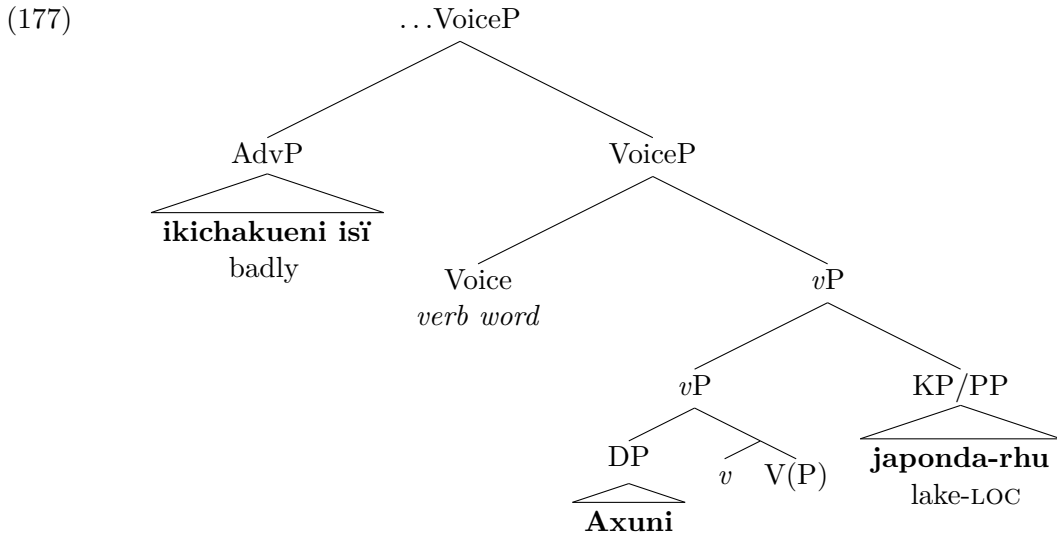

Summarizing, this section has made two main points. First, there is an extra head in the clausal spine between Voice and V (which is here identified with  $v$ ). Secondly, external arguments are generated in [Spec, $v$ P], not in [Spec,VoiceP].

### 5.5.2 Hyperraising to object targets [Spec, $v$ P]

Now that this more accurate picture of Janitzio P’urhepecha clause structure has been arrived at, it can be determined where exactly a hyperraising DP in this language raises to.

Consider the following sentence:

- (178) ?Mentku isĩ **mitsita-ni jingoni** ueka-sin-Ø-di Juanu-ni **Maria**  
 always thus heart-ACC with want-HAB-PRS-IND3 John-ACC Mary  
 eska jaruatpe-a-Ø-ka k’umanchikua-rhu.  
 that help-FUT-PRS-SJV house-LOC  
 ‘Mary always wants John with all her heart to help out at home.’

This sentence features the constituent order MANNER ADVERBIAL (*mitsitani jingoni* ‘with all X’s heart’)  $\gg$  VERB WORD  $\gg$  SUBJECT (*Maria*)  $\gg$  EMBEDDED CP (taking “ $\gg$ ” to mean ‘precedes’, not ‘immediately precedes’). As discussed in §5.5.1, this constituent order indicates that the manner adverbial is left-adjoined to VoiceP, the verb word is being realized in Voice, and the subject is in its base position ([Spec, $v$ P]). These landmarks allow us to pinpoint the precise position of DP<sub>ACC</sub> in (178): it must be in a second (outer) specifier of  $v$ P, as shown below.

(179)

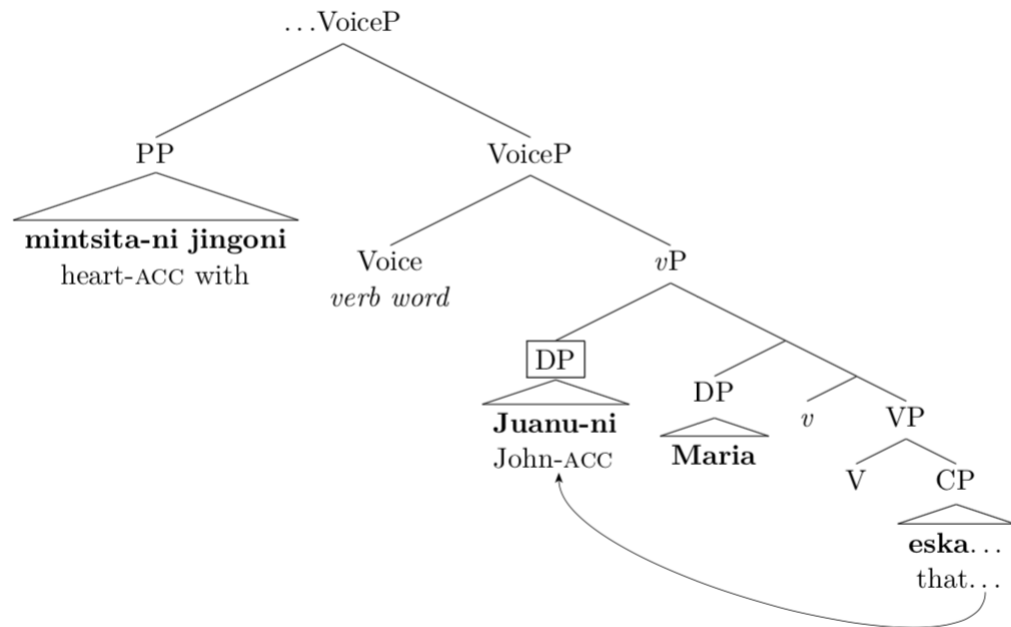

That is, hyperraising to object must target a specifier position of  $vP$ . Now, in (179), the matrix subject (*Maria*) is externally merged with the highest available projection of  $v$ , and then the hyperraising DP is internally merged with the new highest available projection of  $v$ . But if External and Internal Merge are simply subcases of a single operation (Merge—Chomsky 2004, Collins & Stabler 2016:48, Freidin 2016:702, Collins 2017:48, Collins & Groat 2018:1; see Graf 2018 for relevant discussion), then, all else being equal, it should alternatively be possible to internally merge the hyperraising DP and then externally merge the matrix subject, yielding the order MATRIX SUBJECT  $\gg$  DP<sub>ACC</sub>. This is correct:

- (180) (?)Mentku isī **mintsita-ni jingoni** ueka-sin-∅-di **Maria** Juanu-ni  
always thus heart-ACC with want-HAB-PRS-IND3 Mary John-ACC  
eska jaruatpe-a-∅-ka k'umanchikua-rhu.  
that help-FUT-PRS-SJV house-LOC  
'Mary always wants John with all her heart to help out at home.'

It is worth noting that this provides an argument against both Merge over Move (Chom-

sky 1995a, 2000) and Move over Merge (Shima 2000, Larson 2015) (see Freidin 2016:700-702 for discussion). Alternatively, as pointed out to me by Maziar Toosarvandani, it could in principle be that the External and Internal Merge steps are rigidly ordered, but tucking-in (Richards 1997) can optionally occur in this case.

Sentence (180) is quite acceptable, despite its considerable complexity, as shown by the diacritic given for it. Its counterpart in (178) is also reasonably acceptable, though not quite as much—perhaps because the parser expects nominative DPs to precede accusative ones by default, and in (178) the reverse occurs.

Before this section is concluded, it should be mentioned that Amy Rose Deal has proposed to me an alternative analysis (call it Analysis B) on which hyperraising to object in Janitzio P’urhepecha targets not [Spec, *v*P] but [Spec, VP] (cf. Deal 2017:9, (25), (27)), accounting straightforwardly for the MATRIX SUBJECT  $\gg$  DP<sub>ACC</sub> order in (180), and (178) is derived by optional short scrambling of DP<sub>ACC</sub> from [Spec, VP] to [Spec, *v*P]. As she points out, this would make it straightforward to capture the effect of V choice (the fact that hyperraising is possible only with certain Vs). Both analyses must “say something” to account for all the data: Analysis A (but not Analysis B) must capture the effect of V choice by positing that the hyperraising *v* selects only certain Vs; Analysis B (but not Analysis A) must posit optional short scrambling. (The scrambling must target [Spec, *v*P] specifically: attempting to move DP<sub>ACC</sub> in (180)/(178) one specifier position higher, to [Spec, VoiceP], produces a highly degraded result, as shown in (181).)

- (181) ??Mentku isi **mintsita-ni jingoni** Juanu-ni ueka-sin-∅-di **Maria**  
 always thus heart-ACC with John-ACC want-HAB-PRS-IND3 Mary  
 eska jaruatpe-a-∅-ka k’umanchikua-rhu.  
 that help-FUT-PRS-SJV house-LOC  
 int. ‘Mary always wants John with all her heart to help out at home.’

With those provisions made, both analyses are empirically adequate. Analysis A will be further developed here, but it should be noted for reference that Analysis B seems equally viable.

### 5.5.3 Putting it all together (with a derivation)

Let us lay out our analysis of hyperraising to object in Janitzio P’urhepecha by deriving (180) (repeated in (182)).

- (182) (?)Mentku isi **mitsita-ni jingoni** ueka-sin-∅-di **Maria** Juanu-ni  
 always thus heart-ACC with want-HAB-PRS-IND3 Mary John-ACC  
 eska jaruatpe-a-∅-ka k’umanchikua-rhu.  
 that help-FUT-PRS-SJV house-LOC  
 ‘Mary always wants John with all her heart to help out at home.’ (= (180))

First, the core of the embedded CP is built:

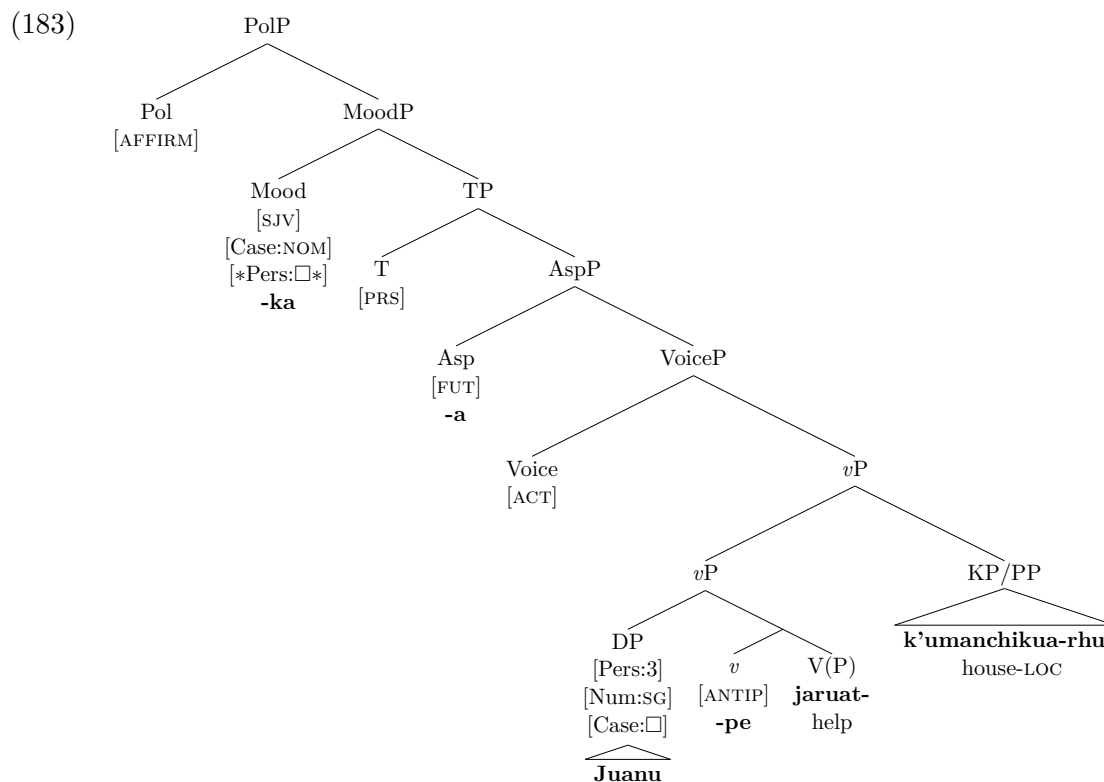

(For ease of exposition, the discussion here abstracts away from the derivational effects of the clause-internal phase, if there is one [e.g., *vP* or *VoiceP*; see Fox 1999, Legate 2003, Harwood 2015, van Urk 2015, van Urk & Richards 2015, Ingason & Wood 2017, a.o.; see also Freidin 2016:693-694 for discussion]. Also, the antipassive suffix *-pe* in

*jaruat-pe-* ‘help-ANTIP’ is tentatively analyzed here as a *v*. None of this should affect the proposals of interest here.)

As shown in (184), the subjunctive Mood head *-ka* bears an unvalued Person probe. (The basis for this supposition is the fact that the *indicative* Mood suffix is a portmanteau that also expones the person of the subject, being realized as *-ka* in the first and second persons and as *-ti* in the third. [These suffixes assimilate to *-ga* and *-di* immediately following /n/.] It will be assumed here for concreteness that the indicative Mood head not only agrees with the subject in person but also assigns it nominative Case, and that the subjunctive Mood head behaves identically—even though it does not agree with the subject overtly, but rather always surfaces as *-ka(/-ga)*. This derivation uses simplified person features such as [Pers:3] for ease of exposition; see Bobaljik 2012:210-212 for relevant discussion.)

The unvalued Person probe on the subjunctive Mood head *-ka* probes its c-command domain for a constituent bearing a valued Person feature, finds [DP *Juanu*], and copies the value for its Person feature (3) onto itself. Another effect of this Agree operation is that the unvalued Case feature of [DP *Juanu*] is valued nominative. The result is as follows.

(184)

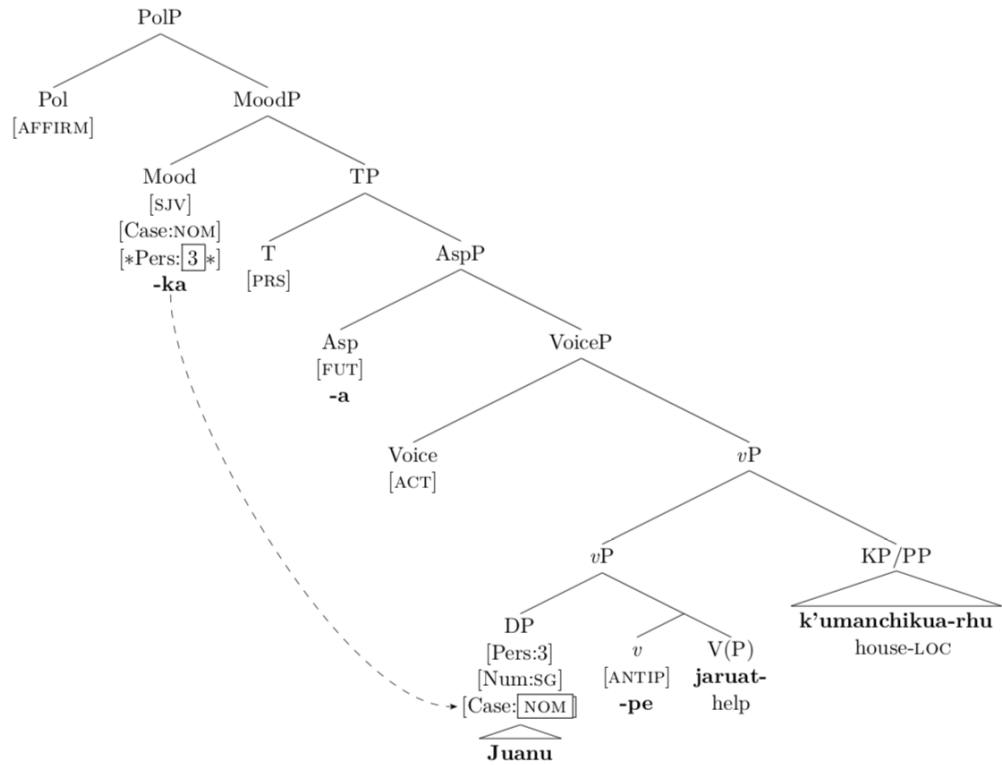

Merged in next is the C *eska* ‘that’. There are two versions of *eska*: one without and one with a feature  $[*D*]^{EPP}$ . In hyperraising to object, the version of *eska* bearing  $[*D*]^{EPP}$  is chosen. It probes its c-command domain for a goal bearing the feature [D] (more precisely, [CAT:D]) and finds  $[_{DP} \textit{Juanu}]$ , thereby satisfying its own  $[*D*]$  feature. This feature’s EPP subfeature forces the goal of the probing operation,  $[_{DP} \textit{Juanu}]$ , to internally merge with the highest projection of *eska* (the traditional  $\bar{C}$ ):



(185)

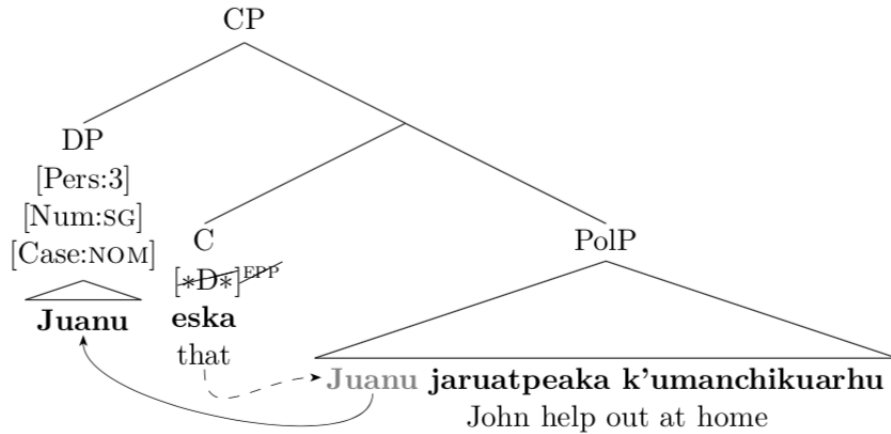

On the standard assumption that CP is a phase, *eska* is a phase head, so its complement (PolP) is spelled out. The highest copy of *Juanu* is at the phase edge, and therefore still accessible. The derivation continues, yielding the following structure:

(186)

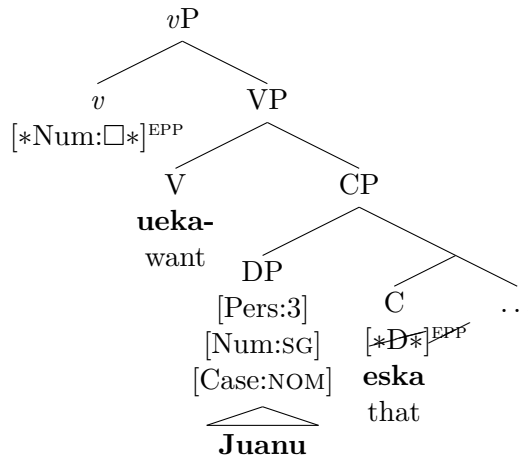

As shown in (186), the hyperraising *v* selects the V *ueka-* ‘want’. (In other derivations, it selects other Vs compatible with hyperraising to object.) This *v* also bears an unvalued Number probe with an EPP subfeature. The Number probe probes *v*’s c-command domain, finds [DP *Juanu*], and copies the value of its Number feature (SG) onto itself, thereby valuing itself singular. That is, *v* is essentially an “object agreement” probe.

The valued Number feature's EPP subfeature forces the goal of the probing operation,  $[_{DP} \textit{Juanu}]$ , to internally merge with the highest projection of  $v$  (the traditional  $\bar{v}$ ):

(187)

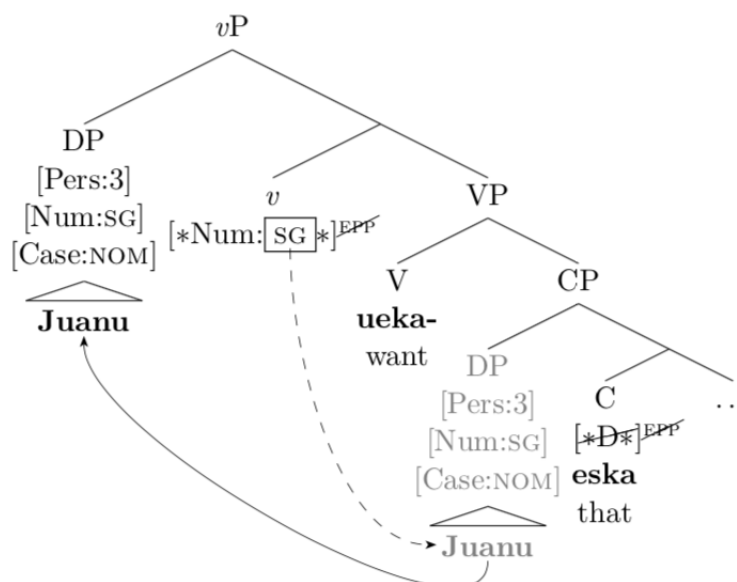

Importantly, the valued Number feature on  $v$  can be expounded overtly. For the consultant who supplied these judgments, a plural  $DP_{ACC}$  optionally triggers the appearance of the plural object agreement morpheme  $-a$  in the matrix verbal complex; omitting this  $-a$  produces a result which is still acceptable but marked by comparison ((188a)). The same pattern obtains in an ordinary transitive clause ((188b)).

- (188) a. Ueka-<sup>M</sup>(a)-s̄in-∅-ga=ni                      mintsita-ni jingoni **Maria-ni** **ka**  
 want-<sup>M</sup>(pO)-HAB-PRS-IND1=1sS    heart-ACC    with    Maria-ACC and  
**Klara-ni** eska pire-a-∅-ka=s̄i.  
 Clara-ACC that sing-FUT-PRS-SBJV=pS  
 ‘I want Maria and Clara with all my heart to sing.’

[Judgments identical when  $DP_{ACC}$  immediately precedes *mintsitani jingoni*.]

- b. Uitsindekua exe-<sup>M</sup>(a)-sī-∅-ka=ni                      **Xumu-ni ka Axuni-ni.**  
 yesterday see-<sup>M</sup>(pO)-PFV-PRS-IND1=1sS Xumo-ACC and Axuni-ACC  
 ‘Yesterday I saw Xumo and Axuni.’

(The question of how the hyperraised DP ends up accusative is set aside here, since our main goal is to understand the precise mechanics of the movements. Three possibilities, schematically described, are the following: 1) case stacking, 2) case overwriting, 3) dependent case assignment [without DP *relicensing*] (Fong 2017b).) Merged in next is the matrix subject (*Maria*):

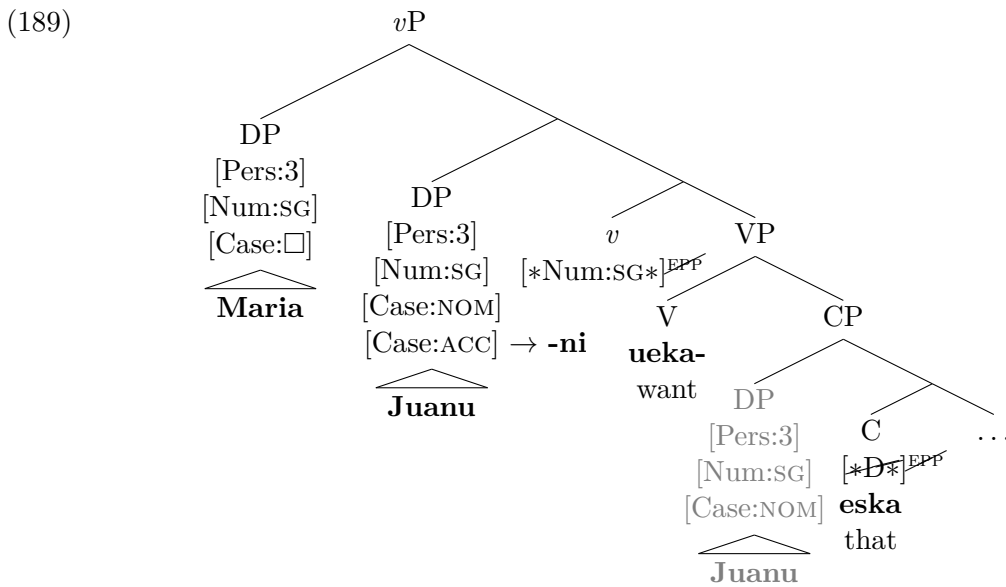

The matrix *vP* merges with Voice, forming a VoiceP, to which the PP *mitsitani jingoni* ‘with all her heart’ left-adjoins. Later, the matrix subject *Maria* values the Person feature of matrix Mood, and receives nominative Case in return. These and other operations complete the derivation of the sentence, which is repeated below.

- (190) (?)Mentku isī    **mitsita-ni jingoni** ueka-sin-∅-di                      **Maria** Juanu-ni  
 always thus heart-ACC    with    want-HAB-PRS-IND3 Mary    John-ACC  
 eska jaruatpe-a-∅-ka    k’umanchikua-rhu.  
 that help-FUT-PRS-SJV house-LOC  
 ‘Mary always wants John with all her heart to help out at home.’ (= (180))



- (192) a. **Greed:** A constituent moves to satisfy a feature of its own.  
 (Chomsky 1995a:201; Bošković 1995, 2002, 2007, 2011, 2018b; Grohmann, Drury, & Castillo 2000; Harwood 2015:528, fn. 8; Holmberg, Sheehan, & van der Wal 2016:11, a.o.; see also Goto 2017a)
- b. **Enlightened Self-Interest:** A constituent moves to satisfy a feature of its own (*greedy* movement) or a feature of the head to whose specifier it moves (*altruistic* movement).  
 (Chomsky 1995a:297, 2000, 2001, 2004, 2008, Lasnik 1995, 2003, McCloskey 2001, Bošković 2004 [appendix], Cable 2012, Ostrove 2016a, 2017b, Werthen 2018, a.o.; see also Nunes 2016)
- c. **Labeling:** A constituent moves so that every relevant constituent in the structure can receive a label from the syntactic Labeling Algorithm.  
 (Chomsky 2013, 2015, 2016, Ott 2015, Rizzi 2015, Smith 2015, Bošković 2018a, a.o.)

The following three subsections argue that P'urhepecha hyperraising to object is neither greedy nor Labeling-driven.

### 5.6.1 Alternative A: Case-driven greedy movement

If hyperraising to object is greedy, it is driven by a feature of the raising DP. A natural possibility is that the DP raises to get Case. It receives accusative Case in the matrix (plausibly from *v*), and consequently surfaces bearing the accusative case morpheme *-ni*.

Assuming that nominative Case is assigned by Mood in Janitzio P'urhepecha (§5.5.3), it would therefore have to be posited that the subjunctive Mood head *-ka*

only optionally bears a [Case:NOM] feature that can Case-license the embedded subject. However, embedded finite CPs whose subjects hyperraise are otherwise identical to embedded finite CPs whose subjects do not hyperraise (and consequently bear nominative case) ((125-128)), which makes the Case-based analysis look artificial. (See also Halpert 2016:187 and Deal 2017:9-10 for arguments that hyperraising is not Case-driven in Zulu or Nez Perce either.)

Even worse for the Case-based analysis, there is evidence that nominative Case is in fact always available in embedded finite CPs in Janitzio P'urhepecha. In hyperraising to object, DP<sub>ACC</sub>, though accusative, can be linked to a *nominative* floated quantifier in the embedded CP:

- (193) [Context: There are three dogs, named Alonzo, Paco, and Puki (= Lion). I want the three of them to play, so that they get enough exercise. I say...]

Ueka-sin-∅-ga=ni                      Alonsu-ni, Paku-ni ka Puki-ni                      **eska**=sī  
 want-HAB-PRS-IND1=1sS Alonzo-ACC, Paco-ACC and Lion-ACC that=pS  
 iamindu-eecha                      ch'ana-a-∅-ka.  
 all-PL(NOM)                      play-FUT-PRS-SJV  
 'I want Alonzo, Paco, and Puki to all play.'

- (194) ?Ueka-pirin-∅-ga=ni                      Maria-ni, Klara-ni ka Ana-ni                      **eska**  
 want-COND-PRS-IND1=1sS Maria-ACC, Clara-ACC and Anna-ACC that  
 iamindu-eecha                      pire-a-∅-ka=sī                      pauani.  
 all-PL(NOM)                      sing-FUT-PRS-SJV=pS tomorrow  
 'I'd like for Maria, Clara, and Anna to all sing tomorrow.'

Regardless of whether floated quantifiers in Janitzio P'urhepecha are stranded adnominal elements (as argued in Chapter 4 and Bošković 2018a) or clause-level adverbials, the acceptability of sentences such as (193-194) strongly suggests that nominative Case is available in the embedded CP even when the subject of this CP hyperraises to object.

As pointed out to me by Bern Samko, a defender of the Case-based analysis could argue that the embedded CP in hyperraising to object is always nominative-

deficient, and the nominative case on a floated quantifier like *iamindueecha* ‘all’ in (193) is a default case. But this would raise the question of why the associate of the floated quantifier does not also receive default nominative case in the embedded CP, rendering hyperraising to object unnecessary (and therefore, by hypothesis, impossible; cf. Bošković & Messick to appear)—particularly given that a floated quantifier in Janitzio P’urhepecha obligatorily matches its associate in case (§4.4) (except, admittedly, when the associate hyperraises to object).

(Sentences such as (193)–(194) also provide evidence that the Activity Condition is not an inherent, universal constraint on Agree [contra Chomsky 2000, 2001]. [For other arguments against the Activity Condition, see Nevins 2004; see also Halpert 2016 and Chomsky 2016, fn. 5.] The floated quantifier shows that nominative Case is available in the embedded CP, suggesting strongly that the embedded subject receives nominative Case as usual. [Indeed, how would this be prevented, since nominative Case is available?] But this DP is still able to hyperraise and enter into further A-relations: it can trigger plural “object agreement” in the matrix (188), and it receives [a new] accusative Case. From the standpoint of our analysis, on which P’urhepecha hyperraising to object is *altruistic* movement, this is a welcome result, since, as pointed out by Bošković [2002:175] and Bošković and Messick [to appear], subjecting supposedly altruistic [target-driven] movement to the Activity Condition essentially smuggles Greed back in through the back door.)

### 5.6.2 Alternative B: Non-Case-driven greedy movement

There is, however, a second possible Greed-based analysis to consider: one on which the feature driving the movement is not a Case feature.

Bošković (2007) argues for an analysis of movement on which all movement is greedy. In his system, not only does every probe bear an unvalued feature, but also, conversely, every element bearing an unvalued feature (e.g., a DP with an unvalued

Case feature) acts as a probe. If (and *only* if) an element bearing an unvalued feature cannot value it under Agree from where it is (by probing its c-command domain), it moves to a c-commanding position and tries to value it under Agree from there.

Let us attempt to extend this analysis to hyperraising to object in Janitzio P'urhepecha. Because a hyperraising DP in this language ends up in a matrix [Spec,*v*P] (§5.5.2), we could posit that a D in Janitzio P'urhepecha (and, derivatively, the DP it heads) can optionally bear a feature [*uv*], and it is this feature that drives hyperraising to object. (This is conceptually less attractive than the Case-based Greed analysis §5.6.1, but still implementable and worth considering. Note that [*uv*] in Bošković's 2007 notation corresponds to [*\*v\**] in the Heck & Müller 2007-style notation used elsewhere in this dissertation.) On this analysis, hyperraising to object would be derived as follows. An embedded subject DP bearing [*uv*] moves to [Spec,CP], the CP phase edge position. (If it doesn't, it will be spelled out with its [*uv*] feature unvalued, causing the derivation to crash.) It then moves to a matrix [Spec,*v*P]. Once there, it c-commands the matrix *v*. It can therefore value its [*uv*] feature under Agree, and the derivation converges.

There are two major problems with this analysis. First, a [*uv*] feature could not cause an embedded subject to raise into the matrix, because the embedded CP also contains a *v*. From the embedded external argument base position ([Spec,*v*P]), the embedded subject would c-command the embedded *v*; it would therefore not have to move at all to satisfy its [*uv*] feature. When the embedded subject was base-generated in an internal argument position, it could satisfy its [*uv*] feature merely by moving to an *embedded* [Spec,*v*P]. Further movement (into the matrix) would be unmotivated and therefore impossible (cf. Bošković & Messick to appear).

Moreover, even if that problem could be dealt with somehow, a second problem would remain. If a D(P) could optionally bear [*uv*], then, in some derivations, [*uv*] would show up on the embedded object and not the embedded subject. Then, the *object* would hyperraise into the matrix. Hyperraising to object would thus be predicted not to show



intervention effects (a hallmark of A-movement-type locality), contrary to fact (§4.2; cf. [McFadden 2003:144-145](#)).

### 5.6.3 Alternative C: Labeling-driven movement

A third possible alternative analysis is one on which hyperraising to object in Janitzio P’urhepecha is indirectly driven by the Labeling Algorithm ([Chomsky 2013, 2015, 2016, Ott 2015, Rizzi 2015, Smith 2015, Bošković to appear, a.o.](#)).

Descriptively speaking, hyperraising to object is optional. It is therefore unlikely that it occurs to solve a labeling problem arising in the embedded CP—e.g., to allow labeling of a (problematically symmetrical) {XP, YP} structure with no feature sharing. Instead, let us try to adapt to the hyperraising case [Chomsky’s \(2015\)](#) analysis of subject-raising to [Spec,TP] in English (also discussed in [§3.2.3](#) but briefly rediscussed here for convenience). Chomsky proposes that in English, but not in Italian, T is too “weak” to label its projections (henceforth simply *weak*), and must therefore be reinforced by raising the most prominent DP to “[Spec,TP]” (using the term *Spec* only for convenience). When this happens, the features shared by the DP and T ( $\phi$ -features) can label the traditional “TP”  $\langle\phi,\phi\rangle$  (though see [Richards 2017:3, fn. 6](#), for a conceptual argument against this conclusion). Returning to hyperraising to object, we could posit that the hyperraising  $v_{[*\text{Num}:\square*]}$  comes in two versions in the lexicon, one strong and one weak. (On this analysis, the hyperraising  $v_{[*\text{Num}:\square*]}$  does not bear an EPP subfeature, since the analysis attempts to attribute to the Labeling Algorithm the effects ascribed to EPP subfeatures on other analyses [specifically, analyses on which movement is feature-driven and can be altruistic]. See [Boeckx 2010](#) for relevant discussion.) When the weak version of  $v_{[*\text{Num}:\square*]}$  is chosen, the matrix “ $vP$ ” will be successfully labeled only if a DP (which also bears a [Num] feature) raises to a matrix “[Spec, $vP$ ].” When the embedded subject DP raises to a matrix “[Spec, $vP$ ],” it and  $v$  share a feature—[Num]—so the “ $vP$ ” can be labeled  $\langle\text{Num},\text{Num}\rangle$ .

This analysis too faces problems. First, the assumption that the hyperraising  $v$  (which is silent) comes in two versions, one of which is too weak to label its projections, is stipulative. As discussed in §3.2.3, Chomsky’s (2015) proposal that English T is weak but Italian T is strong for labeling purposes relates this putative difference to the traditional idea of richness of agreement (Rizzi 1982). Whether this will prove correct is an open question, but at least the analysis relates the putative labeling-strength difference between English and Italian T to something independently observable; this is not possible in the case of the putative labeling-strength difference between the two putative versions of  $v_{[*\text{Num}:\square*]}$  in Janitzio P’urhepecha. Secondly, Chomsky (2015) proposes that V is really a categoryless root R (see Marantz 1997 and other references in Chomsky 2015), and although R is weak, R-to- $v$  raising produces an R- $v$  complex which is strong. *If* this is so, then it cannot be claimed that a certain  $v$  in Janitzio P’urhepecha is weak, because R raises to  $v$  in this language (cf. Chapter 2; note that  $v$ -to-Voice raising carries R along in (178;180)).

## 5.7 Conclusion

This chapter has argued that some speakers of Janitzio P’urhepecha allow *hyperraising to object* (cf. Bruening 2002, Tanaka 2002, Halpert & Zeller 2015, Deal 2017, Fong 2017a,b, 2018, a.o.). The Janitzio P’urhepecha case joins a growing body of evidence that hyperraising is in fact possible in natural languages, indicating that the theory of grammar should not exclude this type of derivational path after all.

Hyperraising to object in Janitzio P’urhepecha was analyzed above as involving two steps of *purely altruistic* movement—i.e., movement driven *exclusively* by a featural requirement of an attracting head. If this analysis is on the right track, it strongly supports the hypothesis known as *Enlightened Self-Interest* (Lasnik 1995, 2003, a.o.)—namely, that movement may be driven either by a feature of the moving element or,

as here, by a feature of an attracting head. (Alternative Greed- and Labeling-based analyses of the phenomenon, by contrast, face serious problems, as shown in §5.6.)

The analysis also contributes to the endeavor of narrowing down the space of possibilities for understanding the A/ $\bar{A}$ -distinction. Janitzio P'urhepecha hyperraising to object suggests that an approach to the distinction on which [Spec,CP] is invariably an  $\bar{A}$ -position, and an element that moves there cannot enter into further A-relations, is untenable. By contrast, a *featural* analysis of A/ $\bar{A}$ -effects—on which A- and  $\bar{A}$ -effects are consequences of the presence of different types of features on particular functional heads (van Urk 2015, Fong 2017a,b, 2018)—looks much more promising. If a language allows the feature  $[*D*]^{EPP}$  to appear not (only) on functional heads in the inflectional layer of the clause (cf. Rizzi 1997:281) but also on a finite C—a possibility which, crucially, nothing in the current theory rules out—then we should *expect* that language to allow A-raising out of finite CPs. Hyperraising to object, then—along with hyperraising to subject—ceases to be an anomaly and is revealed instead to be in line with theoretical expectation.

## Chapter 6

### Conclusion

Consider again the three prominent hypotheses about the driving force for movement that we have been trying to adjudicate among:

- (195) a. **Greed:** A constituent moves to satisfy a feature of its own.  
(Chomsky 1995a:201; Bošković 1995, 2002, 2007, 2011, 2018b; Grohmann, Drury, & Castillo 2000; Harwood 2015:528, fn. 8; Holmberg, Sheehan, & van der Wal 2016:11, a.o.; see also Goto 2017a)
- b. **Enlightened Self-Interest:** A constituent moves to satisfy a feature of its own (*greedy* movement) or a feature of the head to whose specifier it moves (*altruistic* movement).  
(Chomsky 1995a:297, 2000, 2001, 2004, 2008, Lasnik 1995, 2003, McCloskey 2001, Bošković 2004 [appendix], Cable 2012, Ostrove 2016a, 2017b, Werthen 2018, a.o.; see also Nunes 2016)

c. **Labeling:** A constituent moves so that every relevant constituent in the structure can receive a label from the syntactic Labeling Algorithm.

(Chomsky 2013, 2015, 2016, Ott 2015, Rizzi 2015, Smith 2015, Bošković 2018a, a.o.)

This dissertation has brought us closer to the goal of being able to choose among these hypotheses by investigating in detail the properties of two varieties of movement in Janitzio P’urhepecha that are unusual from the perspective of the most intensively studied languages: *profligate subject movement* (cf. Cable 2012 on Dholuo) and *hyperraising to object* (cf. Bruening 2002, Tanaka 2002, Halpert & Zeller 2015, Deal 2017, Fong 2017a,b, 2018). It has been argued here that both of these varieties of movement are *purely altruistic*—i.e., driven exclusively by features of higher, c-commanding heads, with no corresponding featural benefit for the moving element in either case. Alternative analyses of these varieties of movement on which they are *greedy* (driven by features of the moving element) or *labeling-driven* (indirectly forced by the need for every relevant constituent in the structure to receive a label from the Labeling Algorithm) have been argued here to face serious problems. The facts of these two varieties of movement in Janitzio P’urhepecha, then, provide strong evidence in favor of *Enlightened Self-Interest* (the hypothesis that movement may be driven either by a feature of the moving element or, as here, by a feature of the head to whose specifier it moves—Lasnik 1995, 2003, a.o.), and against the *Greed* and *Labeling* hypotheses.

It is worth noting, though, that the evidence for purely altruistic movement (and hence for Enlightened Self-Interest) provided by hyperraising to object is stronger than that provided by profligate subject movement. The reason is that, as pointed out to me by Sandy Chung and by a *Natural Language and Linguistic Theory* reviewer, it is logically possible that profligate subject movement in fact always involves movement of the subject to the highest subject position ([Spec,PolP])—which could probably be

analyzed as greedy or labeling-driven movement without too much stipulation—with optional spellout of non-highest copies. To be sure, it is by no means obvious at this point that such an alternative (non-altruistic) analysis would actually be viable, given that, as shown in Chapter 3, profligate subject movement shows intervention effects. Still, defenders of the Greed and Labeling approaches to driving movement might consider taking up the challenge of trying to reanalyze profligate subject movement in Janitzio P’urhepecha (and in Dholuo, [Cable 2012](#)) in a way that is consistent with their hypotheses and provides some independent motivation for the putative spellout of non-highest copies that such analyses would require. By contrast, the facts of hyperraising to object in Janitzio P’urhepecha seem to pose considerably more severe problems for the Greed and Labeling hypotheses, and it is not at all clear that a truly viable Greed- or Labeling-based analysis is possible for hyperraising to object (at least in its Janitzio P’urhepecha instantiation).

In this connection, it will be worthwhile to mention some of the other theoretical consequences of the investigation of hyperraising to object carried out in Chapter 5. The Janitzio P’urhepecha version of the phenomenon is yet another example of a syntactic process—hyperraising—that is being discovered in more and more languages, indicating that syntactic theory should not in fact exclude this type of derivational path, contrary to what was previously thought. The facts of hyperraising to object in Janitzio P’urhepecha also help us narrow down the space of possibilities for understanding A/ $\bar{A}$ -effects. As discussed in Chapter 5, an analysis of A/ $\bar{A}$ -effects on which [Spec,CP] is inherently and invariably an  $\bar{A}$ -position, and a constituent that moves there cannot enter into further A-relations (A-movement, accusative case assignment, object agreement, etc.), is untenable. By contrast, a featural analysis of A/ $\bar{A}$ -effects—on which A/ $\bar{A}$ -effects are consequences of the features on particular functional heads ([van Urk 2015](#), [Fong 2017b, 2018](#))—looks much more promising. If a language allows the feature  $[*D*]^{\text{EPP}}$  to appear not (only) on functional heads in the inflectional layer of the clause

but also on a finite C (which nothing in the current theory rules out), then we should *expect* that language to allow A-style raising out of finite CPs.

Finally, we should consider what the implications of our results are for a larger question still. If indeed Internal Merge is feature-driven in the way argued for here, and if Internal and External Merge are in fact just two subcases of a single structure-building operation Merge (Chomsky 2004, Collins & Stabler 2016:48, Freidin 2016:702, Collins 2017:48, Collins & Groat 2018:1; see also Graf 2018), then we fully expect External Merge to be feature-driven as well.

This expectation in turn opens up in a salient and straightforward way the possibility that the most accurate theory of the syntax of human languages is one on which *all* syntactic operations are triggered by features of lexical items (and cannot apply in the absence of a suitable trigger of this sort; see Stockwell 2016, §3.2.1; Müller 2017; and Bošković & Messick *to appear* for relevant discussion). On such a theory, lexical items (or, more precisely, the features thereof) are the fundamental drivers and regulators of syntactic derivation—contra the Free Merge approaches (Boeckx 2010; Ott 2010; Chomsky 2013, 2015, 2016; Chomsky, Gallego, & Ott 2017, *a.m.o.*) that have recently seen such a marked and striking surge in interest.

## Appendix A

# How high can the verb raise in Janitzio P'urhepecha?

Section 2.3 argued that the finite verb in Janitzio P'urhepecha can be realized in Voice, Asp, T, or Mood, but no higher. This appendix tests a prediction of that conclusion: that the verb should be able to precede any adverbial that (left-)adjoins at the TP level or below, but no adverbials that (left-)adjoin at the MoodP level or above.

In testing this prediction, let us take as our guide a recent version of the Cinque hierarchy (Cinque 1999). Although the cartographic framework has not been adopted here, it is clear that many of the observations about possible and impossible orders of adverbials that have been incorporated into the Cinque hierarchy are empirically well supported. Therefore, it will be possible to use the Cinque hierarchy to test the prediction just mentioned even without committing ourselves to the cartographic framework. It should be noted, though, that the analysis of Janitzio P'urhepecha clause structure being developed here should be straightforwardly translatable into that framework should that prove desirable.

A recent version of the Cinque hierarchy is given in (196). A few adverbs have been added to it for greater comprehensiveness, but without creating any new positions.

(196) *A recent version of the Cinque hierarchy* (based on Tescari Neto 2013:30, (7))

[**frankly/honestly** Mood<sub>SpeechAct</sub><sup>0</sup>  
[*luckily* Mood<sub>Evaluative</sub><sup>0</sup>  
[*allegedly* Mood<sub>Evidential</sub><sup>0</sup>  
[*probably* Mod<sub>Epistemic</sub><sup>0</sup>  
[*once* T<sub>Past</sub><sup>0</sup>  
[*then* T<sub>Future</sub><sup>0</sup>  
[*perhaps* Mood<sub>Irrealis</sub><sup>0</sup>





Alternatively, the verb can surface to the left of *xarhintkueri* ‘early’, suggesting that Janitzio P’urhepecha has (at least some) optional verb raising:

- (198) verb > *xarhintkueri* ‘early’ ([Spec, Asp<sub>Celerative(II)</sub>P])  
 Iasī nande mikanta-sī-∅-ti **xarhintkueri** meiapekua-ni.  
 today mother close-PFV-PRS-IND3 early store-ACC  
 ‘Today Mom closed the store early.’

It can also surface to the right of the manner adverbials *sesi* ‘well’, *ikichakueni jasi* ‘badly’, and *eskaparini* ‘carefully’ (though *eskaparini*-verb order was judged marked):

- (199) *sesi* ‘well’ ([Spec, VoiceP]) > verb  
 Paula **sesi** pire-sī-∅-ti ma pirekua.  
 Paula well sing-PFV-PRS-IND3 a song  
 ‘Paula sang a song well.’
- (200) *ikichakueni jasi* ‘badly’ ([Spec, VoiceP]) > verb  
 Karlusī **ikichakueni jasi** atanta-sī-∅-ti tsintsikata-ni.  
 Carl badly/uglily paint-PFV-PRS-IND3 wall-ACC  
 ‘Carl painted the wall badly.’
- (201) *eskaparini* ‘carefully’ ([Spec, VoiceP]) > verb  
<sup>M</sup>Julianu **eskaparini** unta-sī-∅-ti porhechi kaka-kata-ni.  
 Julian carefully fix-PFV-PRS-IND3 pot break-PTCP.PASS-ACC  
 ‘Julian carefully fixed (lit. ‘remade’) the broken pot.’

But the verb can also surface to the left of these manner adverbials:

- (202) verb > *sesi* ‘well’ ([Spec, VoiceP])  
 Paula pire-sī-∅-ti **sesi** ma pirekua.  
 Paula sing-PFV-PRS-IND3 well a song  
 ‘Paula sang a song well.’
- (203) verb > *ikichakueni jasi* ‘badly’ ([Spec, VoiceP])  
 Karlusī atanta-sī-∅-ti **ikichakueni jasi** tsintsikata-ni.  
 Carl paint-PFV-PRS-IND3 badly/uglily wall-ACC  
 ‘Carl painted the wall badly.’
- (204) verb > *eskaparini* ‘carefully’ ([Spec, VoiceP])  
 Julianu unta-sī-∅-ti **eskaparini** porhechi kaka-kata-ni.  
 Julian fix-PFV-PRS-IND3 carefully pot break-PTCP.PASS-ACC  
 ‘Julian carefully fixed the broken pot.’

It seems, then, that Janitzio P'urhepecha does indeed have optional verb raising. This conclusion immediately raises the following question: How high can the verb raise in this language?

Let us work our way up the adverb hierarchy:

- (205) verb > *isku jauembarini* 'suddenly' ([Spec, Asp<sub>Inceptive(I)</sub>P])

K'uaki=rini achichi-s-∅-ti **isku jauembarini** juchiti kurinda.  
 crow=1sO eat-PFV-PRS-IND3 suddenly my bread  
 'A crow suddenly ate my bread.'

- (206) verb > *maratitku* 'for a little while' ([Spec, Asp<sub>Durative</sub>P])

Marikua sapi jiska-chi-si-∅-ti=rini **maratitku** juchiti  
 young.woman small hide-APPL.1-PFV-PRS-IND3=1sO a.little.while my  
 takukata-ni, peru jirinanta-si-∅-ka=ni ia.  
 book-ACC but find-PFV-PRS-IND1=1sS already  
 'The girl hid my book for a little while, but I've already found it.'

- (207) verb > *sontku* 'soon' ([Spec, Asp<sub>Proximative</sub>P])

U-a-∅-ka=ni **sontku** ma chekakua jimbani.  
 make-FUT-PRS-IND1=1sS soon a big.canoe new  
 'Soon I'm going to build a new *chekakua* (big canoe).'

- (208) verb > *iasimindu* 'just' ([Spec, Asp<sub>Retrospective</sub>P])

Misitu kaka-si-∅-ti **iasimindu** kukuchi-ni.  
 cat break-PFV-PRS-IND3 now=exactly jug-ACC  
 'The cat just broke the jug.'

- (209) verb > *mentku isi* 'always' ([Spec, Asp<sub>Continuous</sub>P])

Sara pia-sin-∅-di **mentku isi** mansana xarapiti-cha-ni.  
 Sara buy-HAB-PRS-IND3 always thus apple red-PL-ACC  
 'Sara always buys red apples.'

- (210) verb > *utasi* 'still' ([Spec, Asp<sub>Continuative</sub>P])

Laura ataranta-sin-∅-di **utasi** tsuntsu-eecha-ni.  
 Laura sell-HAB-PRS-IND3 still pot-PL-ACC  
 'Laura still sells pots.'

- (211) verb > *ia* 'already' ([Spec, T<sub>Anterior</sub>P])

Ikinari u-si-∅-ti **ia** ma jirumekua jimbani.  
 Ikinari make-PFV-PRS-IND3 already a motorboat new  
 'Ikinari has already built a new motorboat.'

- (212) verb > *jijirisi* ‘quickly’ ([Spec, Asp<sub>Celerative</sub>(I)P])  
 Luisi k’orosita-si-Ø-ti **jijirisi** kojtsitarakua-ni.  
 Louis clean-PFV-PRS-IND3 quickly table-ACC  
 ‘Louis quickly cleaned the table.’
- (213) verb > *uekaparini* ‘voluntarily’ ([Spec, Mod<sub>Volitional</sub>P])  
 Uatsapi=mindu peta-si-Ø-ti **uekaparini** ikichakua ambe.  
 boy=exactly take.out-PFV-PRS-IND3 voluntarily garbage INDEF  
 ‘The boy himself voluntarily took out the trash.’
- (214) verb > *uekaparini* ‘on purpose’ ([Spec, Mod<sub>Volitional</sub>P])  
 Ana kaka-si-Ø-ti **uekaparini** bentana-ni.  
 Anna break-PFV-PRS-IND3 on.purpose window-ACC  
 ‘Anna broke the window on purpose.’
- (215) verb > *ambu exeparini* ‘accidentally’ ([Spec, Mod<sub>Volitional</sub>P])  
 Mateo kaka-si-Ø-ti **ambu exeparini** basu.  
 Mateo break-PFV-PRS-IND3 not carefully glass  
 ‘Matt accidentally broke the glass.’
- (216) verb > *mentku isi* ‘often’ ([Spec, Asp<sub>Frequentative</sub>(I)P])  
 Anaa kamanari-a-sin-Ø-di **mentku isi** uajpe-echa-ni.  
 Anna hug-pO-HAB-PRS-IND3 always thus child-PL-ACC  
 ‘Anna hugs her kids often.’
- (217) verb > *ts’imapurhu isi* ‘twice’ ([Spec, Asp<sub>Frequentative</sub>(I)P])  
 Julia pire-si-Ø-ti **ts’ima-purhu isi** ima-ni pirekua.  
 Julia sing-PFV-PRS-IND3 two-in.n.parts thus that(DIST)-ACC song  
 ‘Julia sang that song twice.’
- (218) verb > *menchani* ‘sometimes’ ([Spec, Asp<sub>Frequentative</sub>(I)P])  
 Jorge pia-sin-Ø-di **menchani** tomaa tsipambiti.  
 George buy-HAB-PRS-IND3 sometimes tomato yellow  
 ‘George sometimes buys yellow tomatoes.’
- (219) verb > *mentku isi* ‘usually, normally’ ([Spec, Asp<sub>Habitual</sub>P])  
 Sara pia-sin-Ø-di **mentku isi** mansana xarapiti-cha-ni.  
 Sara buy-HAB-PRS-IND3 always thus apple red-PL-ACC  
 ‘Sara usually buys red apples.’

The following two sentences initially seem to suggest that, although it is relatively acceptable for the verb to follow *nandi* ‘maybe’ ((220)), it cannot raise past *nandi* ((221)).

(220) *nandi* ‘maybe’ ([Spec, Mood<sub>Irrrealis</sub>P]) > verb  
 ?Axuni **nandi** u-nta-xa-∅-ti kukucha-ni kaka-kata-ni.  
 Axuni maybe make-ITER-DUR-PRS-IND3 jug-ACC break-PTCP.PST-ACC  
 ‘Axuni maybe is fixing the broken jug.’

(221) ?\*verb > *nandi* ‘maybe’ ([Spec, Mood<sub>Irrrealis</sub>P])  
 ?\*Axuni u-nta-xa-∅-ti **nandi** kukucha-ni kaka-kata-ni.  
 Axuni make-ITER-DUR-PRS-IND3 maybe jug-ACC break-PTCP.PST-ACC  
 int. ‘Axuni maybe is fixing the broken jug.’

Under cartographic assumptions, this would seem to suggest that the verb can potentially raise as high as Mood<sub>Irrrealis</sub>, but cannot move one head up, to T<sub>Future</sub> (see (196)). But in fact the verb can move past the *next* adverb up on the Cinque hierarchy—namely, *jimamberi* ‘then’:

(222) verb > *jimamberi* ‘then’ ([Spec, T<sub>Future</sub>P]) (= (20))  
 Materu uexurini ereka-a-∅-ka=sī materu ereta-rhu.  
 another year live-FUT-PRS-IND1=1pS another town-LOC.  
Erenta-a-∅-ka=sī **jimamberi** sanderu sesi.  
 live-FUT-PRS-IND1=1pS then more well  
 ‘Next year we’ll live in another town. Then we’ll live better.’

As mentioned in the body of the chapter, although (222) was judged fully well formed, it is perhaps more usual for verb-*jimamberi* order to be judged a bit marginal in comparison to *jimamberi*-verb order:

(223) *jimamberi* ‘then’ ([Spec, T<sub>Future</sub>P]) > verb ~ ?verb > *jimamberi* ‘then’ (= (21))  
 Uexurini jimbani erenta-a-∅-ka=sī materu k’umanchikua-rhu. Nande  
 year new live-FUT-PRS-IND1=1pS other house-LOC. mother  
 {**jimamberi** pia-a-∅-ti / ?pia-a-∅-ti **jimamberi**} ma  
 {then buy-FUT-PRS-IND3 / ?buy-FUT-PRS-IND3 then} a  
 kojtsitarakua k’eri.  
 table big  
 ‘In the new year we’ll live in a different house. Mom will then buy a big table.’

The verb’s ability to precede *jimamberi* ‘then’ (yielding perfect or slightly marginal results, (222, 223)), but not *nandi* ‘maybe’, suggests that *nandi* ‘maybe’ is higher than *jimamberi* ‘then’ in Janitzio P’urhepecha, contra the predictions of the Cinque hierarchy

(or, more precisely, the version of it under consideration). On the strengths, weaknesses, and crosslinguistic robustness of the Cinque hierarchy, as well as what the ultimate etiology of rigid adverbial orders might be, see [Zyman 2012 and references therein](#).

Proceeding to the next adverbial up for which data are available, the verb can surface to the right of *sesimindu uandantani ia* ‘frankly / honestly / to tell you the truth’:

- (224) *sesimindu uandantani ia* ‘frankly’ ([Spec,Mood<sub>SpeechAct</sub>P]) > verb
- Sesi=mindu uandanta-ni ia,** Xumo sanderu xepe-si-Ø-ti  
 well=very inform-INF already Xumo more be.lazy-PFV-PRS-IND3  
 eska iamindu-eecha.  
 than all-PL  
 ‘Frankly, Xumo’s lazier than everyone else.’

But the verb cannot precede *sesimindu uandantani ia* ‘frankly’:

- (225) ?\*verb > *sesimindu uandantani ia* ‘frankly’ ([Spec,Mood<sub>SpeechAct</sub>P]) (= 31)
- ?\*Xumo xepe-si-Ø-ti **sesi=mindu uandanta-ni ia** sanderu  
 Xumo be.lazy-PFV-PRS-IND3 well=very inform-INF already more  
 eska iamindu-eecha.  
 than all-PL  
 int. ‘Xumo’s frankly lazier than everyone else.’

As noted in the body of the chapter, the unacceptability of 225 cannot simply be due to the sentence-internal placement of *sesimindu uandantani ia* ‘frankly’—a heavy phrase which is in fact a full (nonfinite) clause—since this is perfectly acceptable when it is not the verb but the subject that precedes the adverbial:

- (226) Xumo **sesi=mindu uandanta-ni ia** sanderu xepe-si-Ø-ti  
 Xumo well=very inform-INF already more be.lazy-PFV-PRS-IND3  
 eska iamindu-eecha.  
 than all-PL  
 ‘Xumo frankly is lazier than everyone else.’ (= 32)

In the context of the noncartographic analysis of Janitzio P’urhepecha clause structure developed in the body of the chapter, then, the findings in this appendix, together with those in 23-28 above, support the conclusion that the verb can raise as high as Mood in this language, but no higher. Why this should be is an interesting question that will have to be investigated in crosslinguistic perspective, but must be left open for now.

## Appendix B

### Which quantifiers float in Janitzio P'urhepecha?

Janitzio P'urhepecha has quantifiers that float other than *iamindu-eecha* 'all-PL'. For example, *ts'mararani* 'both' produces reasonably acceptable results when floated either "short-" or "long-distance":

- (227) ⟨**Ts'mararani**⟩ uatsapi-cha ⟨**?ts'mararani**⟩ ch'ana-xa-∅-ti=sī  
⟨both⟩ child-PL ⟨?both⟩ play-DUR-PRS-IND3=pS  
⟨**?ts'mararani**⟩ juata-rhu.  
⟨?both⟩ hill-LOC  
'Both kids are playing on the hill.'

*Kanekua* 'a lot (of)' also seems to be able to float. With this quantifier, "short-distance" float is acceptable (though highly marked), and "long-distance" float is marginally acceptable:

- (228) ⟨**Kanekua**⟩ itsī ⟨<sup>MM</sup>**kanekua**⟩ jata-sī-∅-ti ⟨**?kanekua**⟩  
⟨a.lot.of⟩ water ⟨<sup>MM</sup>a.lot.of⟩ mount-PFV-PRS-IND3 ⟨?a.lot.of⟩  
icharuta-rhu.  
canoe-PL  
'A lot of water got in the canoe.'

*Maru(-eecha)* 'some(-PL)' can either precede or follow its associate, but it cannot float "long-distance":

- (229) ⟨**Maru(?-eecha)**⟩ tumbi-cha ⟨**(?)maru-eecha**⟩  
⟨some(?-PL)⟩ young.man-PL ⟨**(?)some-PL**⟩  
uandontskuari-xa-∅-ti=sī ⟨**\*maru-eecha**⟩ uerakua.  
converse-DUR-PRS-IND3=pS ⟨**\*some-PL**⟩ outside  
'Some young men are chatting outside.'

This may suggest that, in *tumbi-cha maru-eecha* 'young.man-PL some-PL', *maru-eecha* is not a floated quantifier but a rightward (postnominal) modifier.

Finally, numerals such as *tanimu* ‘three’, and the quantifier *uanekua* ‘many’, do not float:

(230) ⟨**Tanimu**⟩ ahati-cha ⟨\***tanimu**⟩ cherema-xa-∅-ti=sī ⟨\***tanimu**⟩  
⟨three⟩ man-PL ⟨\*three⟩ fish.with.net-DUR-PRS-IND3=pS ⟨\*three⟩  
japonda-rhu.  
lake-LOC  
‘Three men are fishing with a net on the lake.’

(231) ⟨**Uanekua**⟩ tumbi-cha ⟨\***uanekua**⟩ uandontskuari-xa-∅-ti=sī  
⟨many⟩ young.man-PL ⟨\*many⟩ converse-DUR-PRS-IND3=pS  
⟨\***uanekua**⟩ uerakua.  
⟨\*many⟩ outside  
‘A lot of young men are chatting outside.’



## Appendix C

### More on quantifier float in ditransitive clauses

As discussed in §4.2.2, in a ditransitive clause in Janitzio P’urhepecha, the direct and indirect objects can surface in either order.

In (232), the indirect object (IO) *Anitani* ‘Anita’ precedes the quantified direct object (DO) *iamindu iajchakueechani* ‘all the pillows’.

(232) *IO-DO order; no quantifier float*

Intsku-a-nta-si-Ø-ka=ni                      Anita-ni    **iamindu iajchakue-echa-ni.**  
give-pO-ITER-PFV-PRS-IND1=1sS Anita-ACC all                      pillow-PL-ACC  
‘I gave Anita all the pillows.’

If the DO-associated quantifier remains to the right of the indirect object *Anitani*, but the associate *iajchakueechani* ‘pillows’ surfaces to the immediate left of this indirect object, the result is unacceptable:

(233) *DO-IO-Q<sub>DO</sub> order is not allowed*

\*Intsku-a-nta-si-Ø-ka=ni                      **iajchakue-echa-ni** Anita-ni  
give-pO-ITER-PFV-PRS-IND1=1sS pillow-PL-ACC                      Anita-ACC  
**iamindu-eecha-ni.**  
all-PL-ACC  
int. ‘I gave Anita all the pillows.’

The paradigm in (232, 233) might initially seem amenable to the following explanation. In Janitzio P’urhepecha, the IO-DO structure is basic, and the DO-IO structure is derived by moving the DO leftward past the IO: [DO ... IO ... *t*<sub>DO</sub>]. However, this movement cannot strand a DO-associated quantifier in the base position of the DO, because quantifiers cannot be stranded in  $\theta$ -positions (Bošković 2004).

In fact, this analysis would also be able to account for analogous facts in DO-IO clauses. In (234), the direct object *siranda* ‘paper’ precedes the quantified indirect object *iamindu jorhengaririchani* ‘all the students’:

(234) *DO-IO order; no quantifier float*

Intsku-a-nta-si-Ø-ka=ni                      siranda **iamindu jorhenguariri-cha-ni**.  
 give-pO-ITER-PFV-PRS-IND1=1sS paper    all                      student-PL-ACC  
 ‘I gave paper to all the students.’

If the IO-associated quantifier remains to the right of the direct object *siranda* ‘paper’, but the associate *jorhenguaririchani* ‘students’ surfaces to the immediate left of this direct object, the result is unacceptable:

(235) *IO-DO-Q<sub>IO</sub> order is not allowed*

\*Intsku-a-nta-si-Ø-ka=ni                      **jorhenguariri-cha-ni** siranda  
 give-pO-ITER-PFV-PRS-IND1=1sS student-PL-ACC                      paper  
**iamindu-eecha-ni**.  
 all-PL-ACC  
 int. ‘I gave paper to all the students.’

Sentence (235) could in principle be ruled out much as (233) was. It contains the substructure [IO<sub>ASSOC-i</sub> ... DO<sub>k</sub> ... [Q<sub>IO</sub> t<sub>i</sub>] ... t<sub>k</sub>]—but this is not allowed, because a quantifier cannot be floated in the base position of the indirect object, which is a  $\theta$ -position.

Although this seems like an elegant account of the paradigm in (232-235), there is reason to believe it is not the right analysis. When long-distance quantifier float occurs, a DO-associated floated quantifier can either precede or follow the IO ((236)), and an IO-associated floated quantifier can either precede or follow the DO ((237)).

(236) *A DO-associated floated quantifier can precede or follow the IO*

[Context: Two brothers are talking about their dad.]

A: ¿Ne-ni    intsku-a-nta-si-Ø-ki                      misitu-eecha-ni?  
           who-ACC give-pO-ITER-PFV-PRS-INT cat-PL-ACC  
           ‘Who did he give the cats to?’

B<sub>1</sub>: Misitu-eecha-ni ambu mite-Ø-Ø-Ø,                      peru **uichu-eecha-ni**  
           cat-PL-ACC    not    know-PFV-PRS-IND but dog-PL-ACC  
           intsku-a-nta-si-Ø-ti                      **iamindu-eecha-ni** Anita-ni.  
           give-pO-ITER-PFV-PRS-IND3 all-PL-ACC                      Anita-ACC  
           ‘The cats I don’t know (about), but the dogs he gave all of to Anita.’

B<sub>2</sub>: ?Misitu-eecha-ni ambu mite-Ø-Ø-Ø,                      peru **uichu-eecha-ni**  
           cat-PL-ACC    not    know-PFV-PRS-IND but dog-PL-ACC  
           intsku-a-nta-si-Ø-ti                      Anita-ni **iamindu-eecha-ni**.  
           give-pO-ITER-PFV-PRS-IND3 Anita-ACC all-PL-ACC  
           ‘The cats I don’t know (about), but the dogs he gave Anita all of.’

(237) *An IO-associated floated quantifier can precede or follow the DO*

[Context: Two sisters are talking about their mom.]

A: ¿Ambe intsku-a-nta-si-∅-ki charaku-eecha-ni?  
 what give-pO-ITER-PFV-PRS-INT baby-PL-ACC  
 ‘What did she give to the babies?’

B<sub>1</sub>: Charaku-eecha-ni ambu mite-∅-∅-∅, peru **uatsapi-cha-ni**  
 baby-PL-ACC not know-PFV-PRS-IND but child-PL-ACC  
 intsku-a-nta-si-∅-ti **iamindu-eecha-ni** tekua ambe.  
 give-pO-ITER-PFV-PRS-IND3 all-PL-ACC honey INDEF  
 ‘The babies I don’t know (about), but the kids she gave all of honey.’

B<sub>2</sub>: ?Charaku-eecha-ni ambu mite-∅-∅-∅, peru **uatsapi-cha-ni**  
 baby-PL-ACC not know-PFV-PRS-IND but child-PL-ACC  
 intsku-a-nta-si-∅-ti tekua ambe **iamindu-eecha-ni**.  
 give-pO-ITER-PFV-PRS-IND3 honey INDEF all-PL-ACC  
 ‘The babies I don’t know (about), but the kids she gave honey to all of.’

The generalizations about these structures are as follows. When a floated quantifier associated with one object precedes the other object, the structure is perfect. When the floated quantifier occurs in absolute clause-final position, the structure is marginally acceptable. Crucially, though, this is so regardless of which object (direct or indirect) the floated quantifier is associated with.

These facts are not compatible with an analysis of (232-235) on which one order for the two objects is derived from the other and (following Bošković 2004) quantifiers cannot be floated in  $\theta$ -positions. On such an analysis, two of the sentences in (236-237) would be predicted to be unacceptable.

All the data in this appendix can, however, be accounted for by positing that both the DO-IO and the IO-DO structure are base-generated in Janitzio P’urhepecha (as argued for Japanese by Miyagawa & Tsujioka 2004, a.o.). If this is so, then (233) and (235) involve unmotivated movement of the associate and are plausibly ruled out for that reason.

As for the putative ban on quantifier float in  $\theta$ -positions, the data in (236-237) seem to constitute a prima facie challenge to it. Alternatively, it could be that the ban is in fact in force, and none of the floated quantifiers in (236-237) are in  $\theta$ -positions, the internal structure of VoiceP being more complex than it initially appears. (The same issue arises in connection with floated quantifiers associated with shifted objects in Irish nonfinite clauses; see McCloskey 2017:264.)

## Appendix D

# Evaluating two alternative analyses of the Subject Condition effects

### D.1 Bošković 2018a

Bošković (2018a) argues that the Subject Condition is one of many effects of a ban on movement out of moved elements (i.e., it is a freezing effect; see his paper for extensive references). On this analysis, extraction from subjects is generally impossible because subjects generally move. Interestingly, though, his analysis of freezing effects leaves room for a class of exceptions, in a way that makes it possible to correctly distinguish between the cases in Janitzio P’urhepecha in which a Subject Condition effect is observed and those in which no such effect is observed.

Bošković develops a Labeling-based analysis of freezing effects, according to which unlabeled constituents cannot move. The analysis works as follows. Suppose we want to move a phrase YP out of another phrase XP that has itself moved. Bošković, following several other researchers, assumes that only phases can move. If this is so, then XP must be a phase. Therefore, in order for YP to move out of XP, it must first move to the edge of XP. The principle of cyclic derivation dictates that YP must move to the edge of XP before XP itself moves. When YP moves to the edge of XP, the result is an {XP, YP} structure, in Labeling terms (Chomsky 2013, 2015; call this structure Z for convenience). If YP and XP do not share a feature that can label Z, Z will be temporarily unlabeled. (If the derivation is to converge, either XP or YP must move, allowing the other to label Z; see Chomsky 2013:43-44.) Therefore, Bošković argues, Z is (at that point in the derivation) not a phase, because it is not a *v*P or CP, or any other type of phrase which is phasal (if there are such). Because Z is not a phase, it cannot move. A fortiori, it is impossible for Z to move and YP to subsequently move out of it.

This explains why *neri* ‘who.GEN’ cannot move out of the nominal *ma p’itakata neri* ‘a picture of whom’ in (119-120), assuming that those two phrases do not share a feature (e.g., a categorial feature [CAT:D]) that could label the {XP, YP} structure [[*neri*<sub>6</sub>] [*ma p’itakata* \_\_<sub>6</sub>]], and assuming that subjects always undergo at least some

movement in Janitzio P’urhepecha (i.e., they in fact originate in some position lower than [Spec,VoiceP] but obligatorily vacate that low base position).

However, Bošković’s analysis also predicts that YP *should* be able to move out of XP if they share a feature (call it [F]) that can label Z. When YP moves to the edge of XP, if YP and XP both bear [F], this feature can label Z. Because Z (now in fact FP) is labeled, it can in principle be a phase. Therefore, it can move, and YP can subsequently move out of it—i.e., the freezing effect is called off. Bošković actually argues that quantifier float in Janitzio P’urhepecha (as well as German and Hebrew) is precisely an instance of this. In Janitzio P’urhepecha, the quantifier *iamindu(eecha)* ‘all(-PL)’ agrees with its associate in number optionally when quantifier float does not occur, but obligatorily when it does. This is explained by Bošković’s analysis: feature-sharing in the structure [[Associate]<sub>7</sub> [D 7]] (specifically, sharing of the feature [Num:PL]) calls off the freezing effect (the Subject Condition effect) that would otherwise have arisen, allowing the associate to move further.

Another piece of evidence supporting this analysis comes from extraction from certain adjuncts. As shown in (107), quantifier float is possible from a comitative adjunct (one bearing the comitative case morpheme *-nguni* ‘with’). However, ordinary *wh*-extraction is not possible from such an adjunct:

- (238) \*  $\int$ Ne-ri<sub>7</sub> kara-xa- $\emptyset$ -ki uatsapi [7 karanaritakua-nguni]?  
 who-GEN<sub>7</sub> write-DUR-PRS-INT boy [7 writing.implement-COM]  
 int. ‘Whose pencil is the boy writing with?’

Bošković (2018a) argues that Adjunct Condition effects (like Subject Condition effects, and freezing effects in general) are called off if the extractee, once at the left edge of the adjunct, shares a feature with its sister that can label their mother. Importantly in this connection, extraction from a comitative adjunct in Janitzio P’urhepecha improves significantly if the extractee overtly bears comitative case as well:

- (239) ?  $\int$ Ne-ri-**nguni**<sub>8</sub> kara-xa- $\emptyset$ -ki uatsapi [8 karanaritakua-**nguni**]?  
 who-GEN-COM<sub>8</sub> write-DUR-PRS-INT boy [8 writing.implement-COM]  
 ‘Whose pencil is the boy writing with?’

This finding makes it possible to understand why, although the Adjunct Condition is in force in Janitzio P’urhepecha ((238)), quantifier float does not display Adjunct Condition effects in this language ((107)). When the associate DP moves to the edge of the containing nominal, it and its sister share a comitative case feature. This feature-sharing calls off the Adjunct Condition effect that would otherwise have been observed, and has a visible reflex in that both the moved associate DP and the stranded quantifier overtly bear the comitative case morpheme *-nguni* ‘with’.

If Bošković’s (2018a) analysis is adopted, then, we can maintain the stranding analysis for quantifier float in Janitzio P’urhepecha—which explains the distributional and case-matching facts (Sects. 4.3–4.4) better than the adverbial analysis—while simultaneously explaining why quantifier float in this language does not show Subject Condition or (oblique) Adjunct Condition effects, unlike ordinary *wh*-movement.

Although this analysis is elegant and achieves impressive empirical results, it faces some problems as well. First, as mentioned above, it requires positing that *all* subjects undergo some movement in Janitzio P’urhepecha. In other words, even a subject that surfaces as low as [Spec,VoiceP] must have moved there from a lower position. As a matter of fact, it will be shown in Chapter 5 that external-argument subjects *can* surface lower than [Spec,VoiceP]—more precisely, in the specifier of a head *v* distinct from Voice. This, however, does nothing to alleviate the problem under discussion. Given that a subject can surface in [Spec,*v*P], Bošković’s (2018a) analysis is in fact forced to posit that all subjects, even external-argument subjects, originate in a position even lower than *that*, but they all obligatorily vacate their base position. Although this is logically possible, there is currently no evidence that all subjects (even those that surface as low as [Spec,*v*P]) move to their surface position from a lower position. The assumption that there always is such a lower position, lower even than [Spec,*v*P], is therefore a pure stipulation needed to get the analysis to work for Janitzio P’urhepecha.

There is, however, a second and substantially more serious problem with Bošković’s (2018a) analysis, which becomes particularly clear when considered in crosslinguistic perspective. Bošković’s analysis predicts that, in the absence of feature-sharing at the edge, movement out of moved elements should be impossible *in general*. This prediction faces severe challenges from English. In this language (in elevated registers) an argument PP can be extracted from an internal-argument DP that itself undergoes A-movement to [Spec,TP]—in a passive or unaccusative clause, for example (cf. Chomsky 2008). This is illustrated in (240, 242) below. In these sentences, there is strong evidence that the extracted PP does indeed originate inside the moved subject DP: in each case, the P heading the PP is lexically selected by the N at the core of the DP (or possibly, in some cases, by a V or categoryless root [Marantz 1997, Chomsky 2015, 2016, a.o.] within the “noun”; see Merchant 2018, esp. §2.6, for relevant discussion).

- (240) a. To whom is obedience demanded by the law?  
 b. To what sorts of parents would a close attachment generally be discouraged?  
 c. To which emotions would a marked proneness on his part be lamented by all?  
 d. To whom had a resemblance been developed by the politician?  
 e. To which performances had tickets been purchased by the event organizer?
- (241) a. For what function had a specialization been developed by the organ?  
 b. For what chemicals is an affinity displayed by these cells?  
 c. For whom had an unexpected affection been developed by the protagonist?  
 d. For what actions could a capacity be developed by such a simple organism?  
 e. For what type of art had a talent been developed by the sophomores?  
 f. For what activities had a penchant been developed by the students?

- (242) a. From which islands is extraction most readily tolerated?  
 b. From which of these airports can a timely departure be expected?  
 c. From which institutions is alienation engendered by grinding poverty?  
 d. From which bank account had a withdrawal been attempted?  
 e. From what portion of public life had retirement been recommended by the therapist?  
 f. From which of his relatives had a temporary separation been recommended?

For these reasons, Bošković's (2018a) analysis of Subject Condition effects, despite its considerable virtues, is problematic and will not be adopted here.

## D.2 Ott 2015

Ott (2015) argues for a different Labeling-based analysis of quantifier float, on which the quantifier (analyzed as a [phrasal] QP) and its associate DP are initially merged as in (243) below.



Because (243) is an {XP, YP} structure (call it  $\alpha$ ), it is unlabelable. Therefore, either DP or QP must move, allowing the other phrase to label  $\alpha$ . When DP moves, QP is stranded (and labels  $\alpha$ ), yielding quantifier float. Ott posits that the following holds (p. 179, (61)):

- (244) In a syntactic object [<sub>ZP</sub> ... XP ... ], ZP can be a barrier for extraction of XP.

That is, he hypothesizes that constituents that block extraction do so in virtue of their category labels (see his §4.3.2). If this is so, then  $\alpha$  (= (243) above) cannot block extraction of DP, because it has no label before DP extracts. This hypothesis, together with other parts of Ott's analysis, accounts elegantly for the immunity of German quantifier float (and German split topicalization) to certain island constraints that are otherwise robust in German—namely, the prohibitions on extraction out of dative objects, free datives, and other adjuncts.

Can this approach to quantifier float and islandhood be extended to Janitzio P'urhepecha? Suppose the structure in (243) is correct for this language. If (243) were generated in [Spec, VoiceP], then, on Ott's assumptions, we would correctly expect DP to be extractable (i.e., quantifier float would be correctly predicted not to show Subject Condition effects). Extraction of a *wh*-phrase from a subject nominal, by contrast, is not possible ((119)–(120)). This could be accounted for as follows. When the *wh*-phrase moves to the edge of the subject DP (presumably because DP is a phase), the structure is as in (245):

(245)



The *wh*-phrase and its sister share a feature—the categorial feature [CAT:D]—which might reasonably be expected to label their mother (call it  $\beta$ ). If DP is a barrier for extraction in Janitzio P’urhepecha (i.e., ZP in (244) can be DP), then  $\beta$ , being a DP, will block extraction of the *wh*-phrase—the right result. However, this analysis is too restrictive, because it incorrectly predicts that it should be equally impossible to extract a *wh*-phrase from an object nominal in Janitzio P’urhepecha, which in fact is possible ((118)). It seems, then, that Ott’s (2015) approach to islandhood cannot be extended to explain the profile of Subject Condition effects in Janitzio P’urhepecha.



## References

- Adler, Jeff, Steven Foley, Jed Pizarro-Guevara, Kelsey Sasaki, and Maziar Toosarvandani. 2018. "The derivation of verb initiality in Santiago Laxopa Zapotec." In *A Reasonable Way to Proceed: Essays in honor of Jim McCloskey*, ed. Jason Merchant, Line Mikkelsen, Deniz Rudin, and Kelsey Sasaki. 31-49. Available online at <https://escholarship.org/uc/item/7z29n70x>.
- Al Khalaf, Eman. Submitted. "Arabic Quantifier Float Revisited." Under review at *Folia Linguistica*.
- Alexiadou, Artemis, and Elena Anagnostopoulou. 1998. "Parametrizing Agr: Word Order, V-Movement and EPP-Checking." *Natural Language and Linguistic Theory* 16: 491-539.
- Angeles, Andrew. 2017. "Agreement and Head-to-Head Movement in Premodern Japanese *Kakari-Musubi* Focus Constructions." Ms., University of California, Santa Cruz.
- Arregi, Karlos, and Asia Pietraszko. 2018. "Generalized head movement." In *Proceedings of the Linguistic Society of America*, Vol. 3. Ed. Patrick Farrell. 5:1-15.
- Baclawski Jr., Kenneth. 2017. "Clause-final particles and focus in Eastern Cham." *Proceedings of the Linguistic Society of America*, Vol. 2. Ed. Patrick Farrell. 18:1-12.
- Bailey, Laura. 2010. "Latin Word Order and the EPP." Handout from CamLing, Cambridge University.
- Baker, Mark. 1985. "The Mirror Principle and Morphosyntactic Explanation." *Linguistic Inquiry* 16.3: 373-415.
- Baltin, Mark. 1995. "Floating Quantifiers, PRO, and Predication." *Linguistic Inquiry* 26.2: 199-248.

- Barss, Andrew, and Howard Lasnik. 1986. "A Note on Anaphora and Double Objects." *Linguistic Inquiry* 17.2: 347-54.
- Benmamoun, Elabbas. 1999. "The Syntax of Quantifiers and Quantifier Float." *Linguistic Inquiry* 30.4: 621-642.
- Ben-Meir, Netta. 2016. "Verb Initiality in Modern Hebrew." Ms., University of California, Santa Cruz.
- Bhatia, Sakshi, Leland Paul Kusmer, and Ekaterina Vostrikova. 2016. "Indirect interaction of person and number." Handout from GLOW 39, Göttingen. Available online at <http://lelandpaul.com/pdf/bhatia-glow39.pdf>.
- Bibbs, Richard. 2018. "Restrictions on Pied Piping and Preposition Stranding out of Derived Positions." Ms., University of California, Santa Cruz.
- Bobaljik, Jonathan David. 2003. "Floating quantifiers: Handle with care." *The Second Glot International State-of-the-Article Book*. Berlin: Mouton de Gruyter. 107-48. Studies in Generative Grammar. Available online at <http://bobaljik.uconn.edu/papers/FQII.pdf>.
- Bobaljik, Jonathan David. 2012. *Universals in Comparative Morphology: Suppletion, Superlatives, and the Structure of Words*. Cambridge, MA: MIT.
- Bobaljik, Jonathan David, and Dianne Jonas. 1996. "Subject Positions and the Roles of TP." *Linguistic Inquiry* 27.2: 195-236.
- Boeckx, Cedric. 2010. "A tale of two minimalisms: Reflections on the plausibility of crash-proof syntax, and its free-merge alternative." In *Exploring Crash-Proof Grammars*, ed. Michael T. Putnam. Amsterdam: John Benjamins. 105-123.
- Borer, Hagit. 1984. *Parametric Syntax: Case Studies in Semitic and Romance Languages*. Dordrecht: Foris.
- Borise, Lena, and Maria Polinsky. In press. "Focus without movement: syntax-prosody interface in Georgian." Proceedings of *NELS 2017*.
- Bošković, Željko. 2002. "A-Movement and the EPP." *Syntax* 5.3: 167-218.
- Bošković, Željko. 2004. "Be Careful Where You Float Your Quantifiers." *Natural Language and Linguistic Theory* 22.4: 681-742.

- Bošković, Željko. 2008. "What will you have, DP or NP?" In *Proceedings of the North East Linguistics Society 37*. Ed. Emily Elfner and Martin Walkow. Amherst: UMass Amherst. 101-114.
- Bošković, Željko. 2011. "On Unvalued Uninterpretable Features." *Proceedings of the North East Linguistic Society 39*. Ed. Suzi Lima, Kevin Mullin, and Brian Smith. Amherst, MA: GLSA (Graduate Linguistic Student Association), I. 109-20.
- Bošković, Željko. 2018a. "On Movement out of Moved Elements, Labels, and Phases." *Linguistic Inquiry* 49.2: 247-282.
- Bošković, Željko. 2018b. "On The Coordinate Structure Constraint, Across-the-Board-Movement, Phases, and Labeling." Ms., University of Connecticut. Available online at <http://ling.auf.net/lingbuzz/003894>.
- Bošković, Željko, and Serkan Şener. 2014. "The Turkish NP." *Crosslinguistic Studies on Noun Phrase Structure and Reference*. Ed. Patricia Cabredo Hofherr and Anne Zribi-Hertz. Leiden: Brill. 102-140.
- Bošković, Željko, and Troy Messick. To appear. "Derivational Economy in Syntax and Semantics." In *Oxford Research Encyclopedia of Linguistics*. Ed. Mark Aronoff. Oxford University Press.
- Bowers, John. 1993. "The Syntax of Predication." *Linguistic Inquiry* 24.4: 591-656.
- Bowers, John. 2002. "Transitivity." *Linguistic Inquiry* 33.2: 183-224.
- Brisson, Christine. 1998. *Distributivity, Maximality, and Floating Quantifiers*. Diss. Rutgers University.
- Bruening, Benjamin. 2002. "Raising to Object and Proper Movement." Ms., University of Delaware. Available online at <http://udel.edu/~bruening/Downloads/RTO1.pdf>.
- Bruening, Benjamin. 2014. "Precede-and-command revisited." *Language* 90.2: 342-388.
- Bruening, Benjamin. 2015. "Light Verbs Are Just Regular Verbs." *University of Pennsylvania Working Papers in Linguistics 22.1: Proceedings of the 39th Annual Penn Linguistics Colloquium*. Available online at <http://repository.upenn.edu/pwpl/vol22/iss1/7/>.
- Bruening, Benjamin. 2017. *Consolidated Morphology: A Non-Distributed, Purely Syntactic Theory of Morphology*. Ms., University of Delaware. Available online at <http://udel.edu/~bruening/Downloads/ConsMorphosyntax1.pdf>.

- Burzio, Luigi. 1986. *Italian Syntax: A Government-Binding Approach*. Dordrecht: D. Reidel.
- Cable, Seth. 2010. *The Grammar of Q: Q-Particles, Wh-Movement, and Pied-Piping*. Oxford: Oxford University Press.
- Cable, Seth. 2012. "The optionality of movement and EPP in Dholuo." *Natural Language and Linguistic Theory* 30: 651-97.
- Capistrán, Alejandra. 2002. "Variaciones de orden de constituyentes en p'orhépecha. Topicalización y focalización." *Del cora al maya yucateco: estudios lingüísticos sobre algunas lenguas indígenas mexicanas*. Ed. Paulette Levy. Mexico City: Universidad Nacional Autónoma de México (UNAM). 349-402. Estudios sobre lenguas americanas.
- Capistrán Garza, Alejandra. 2015. *Multiple Object Constructions in P'orhépecha: Argument Realization and Valence-Affecting Morphology*. Leiden: Brill. Brill's Studies in the Indigenous Languages of the Americas 9.
- Cardinaletti, Anna. 2004. "Toward a Cartography of Subject Positions." In *The Structure of CP and IP*. Ed. Luigi Rizzi. New York: Oxford University Press. 115-165.
- Carnie, Andrew. 2000. "On the Definition of X<sup>0</sup> and XP." *Syntax* 3.2: 59-106.
- Carstens, Vicki and Michael Diercks. 2013. "Parameterizing Case and Activity: Hyper-raising in Bantu." In *Proceedings of NELS 40*. Ed. Seda Kan, Claire Moore-Cantwell, and Robert Staubs. Amherst: GLSA. 99-118.
- Chamoreau, Claudine. 2007. "Looking for a new participant. The Purepecha passive." *Studies in Voice and Transitivity (Estudios de voz y transitividad)*. Ed. Zarina Estrada Fernández, Søren Wichmann, Claudine Chamoreau, and Albert Álvarez González. Munich: LINCOM Europa. 127-145.
- Chomsky, Noam. 1970. "Remarks on Nominalization." In *Readings in English Transformational Grammar*, ed. Roderick A. Jacobs and Peter S. Rosenbaum. Waltham, MA: Ginn.
- Chomsky, Noam. 1993. "A Minimalist Program for Linguistic Theory." In *The view from Building 20: Essays in Linguistics in Honor of Sylvain Bromberger*, ed. Kenneth Hale and Samuel Jay Keyser. Cambridge, MA: MIT Press. 1-52.
- Chomsky, Noam. 1995a. *The Minimalist Program*. Cambridge, MA: MIT Press.

- Chomsky, Noam. 1995b. “Bare Phrase Structure.” In *Evolution and Revolution in Linguistic Theory: Studies in Honor of Carlos P. Otero*. Eds. Héctor Campos and Paula Kempchinsky. Washington, D.C.: Georgetown University Press. 51-109.
- Chomsky, Noam. 2000. “Minimalist inquiries: the framework.” In *Step by Step: Essays on Minimalist Syntax in Honor of H. Lasnik*. Ed. Roger Martin, David Michaels, Juan Uriagereka. Cambridge: MIT Press. 89-155.
- Chomsky, Noam. 2001. “Derivation by Phase.” In *Ken Hale: A Life in Language*. Ed. Michael Kenstowicz. Cambridge, MA: MIT Press. 1-52.
- Chomsky, Noam. 2004. “Beyond Explanatory Adequacy.” In *The Cartography of Syntactic Structures, Vol. 3. Structures and Beyond*. Ed. Adriana Belletti. Oxford: Oxford University Press. 104-31.
- Chomsky, Noam. 2008. “On Phases.” In *Foundational Issues in Linguistic Theory: Essays in Honor of Jean-Roger Vergnaud*. Ed. Robert Freidin, Carlos Peregrín Otero, and Maria Luisa Zubizarreta. Cambridge: MIT Press. 133-166.
- Chomsky, Noam. 2013. “Problems of projection.” *Lingua* 130: 33-49.
- Chomsky, Noam. 2015. “Problems of projection: Extensions.” In *Structures, Strategies and Beyond: Studies in honour of Adriana Belletti*, eds. Elisa Di Domenico, Cornelia Hamann, and Simona Matteini. Amsterdam/Philadelphia: John Benjamins. 3-16.
- Chomsky, Noam. 2016. “Puzzles about Phases.” In *Linguistic Variation: Structure and Interpretation. Contributions in Honor of M. Rita Manzini*, ed. Ludovico Franco, Paolo Lorusso, and Giulia Bellucci. Berlin: De Gruyter.
- Clem, Emily. 2018. “Amahuaca ergative as agreement with multiple heads.” Ms., University of California, Berkeley. Available online at <http://linguistics.berkeley.edu/~eclem/clem-2017-amahuaca-ergative-ms.pdf>.
- Cinque, Guglielmo. 1999. *Adverbs and Functional Heads: A Cross-Linguistic Perspective*. New York: Oxford University Press.
- Collins, Chris, and Edward Stabler. 2016. “A Formalization of Minimalist Syntax.” *Syntax* 19.1: 43-78.
- Collins, Chris. 2017. “Merge(X,Y) = {X,Y}.” In *Labels and Roots*. Ed. Leah Bauke, Andreas Blümel, and Erich Groat. De Gruyter Mouton.

- Collins, Chris, and Erich Groat. 2018. "Distinguishing Copies and Repetitions." Ms. Available online at <http://ling.auf.net/lingbuzz/003809>.
- Compton, Richard, and Christine Pittman. 2010. "Word-formation by phase in Inuit." *Lingua* 120: 2167-2192.
- Culicover, Peter and Kenneth Wexler. 1977. "Some syntactic implications of a theory of language learnability." In *Formal Syntax*. Ed. Peter Culicover, Thomas Wasow, and Adrian Akmajian. New York: Academic Press. 7-60.
- Danckaert, Lieven. To appear. "Subject Placement in the History of Latin." *Catalan Journal of Linguistics*. Available online at <http://ling.auf.net/lingbuzz/003481>.
- Deal, Amy Rose. 2017. "Covert hyperraising to object." *Proceedings of NELS 47*, ed. Andrew Lamont and Katerina Tetzloff. Available online at <http://ling.auf.net/lingbuzz/003517>.
- Desai, Mansi. 2017a. "Gujarati: Word Order and Agreement." Ms., University of California, Santa Cruz.
- Desai, Mansi. 2017b. "Negation in Gujarati." Handout from Syntax & Semantics Circle (S-Circle), University of California, Santa Cruz.
- Devine, A. M., and Laurence D. Stephens. 2006. *Latin Word Order: Structured Meaning and Information*. Oxford: Oxford University Press.
- Diesing, Molly. 1998. "Light verbs and the syntax of aspect in Yiddish." *The Journal of Comparative Germanic Linguistics* 1.2: 119-156.
- Doetjes, Jenny. 1992. "Rightward floating quantifiers float to the left." *The Linguistic Review* 9: 313-332.
- Embick, David, and Rolf Noyer. 2001. "Movement Operations after Syntax." *Linguistic Inquiry* 32.4: 555-595.
- Epstein, Samuel David, Acrisio Pires, and T. Daniel Seely. 2005. "EPP in T: More Controversial Subjects." *Syntax* 8.1: 65-80.
- Erlewine, Michael Yoshitaka. To appear. "Extraction and licensing in Toba Batak." *Language*. Manuscript available online at <http://ling.auf.net/lingbuzz/003261>.
- Ernst, Thomas. 2002. *The Syntax of Adjuncts*. Cambridge, UK: Cambridge University Press.

- Fitzpatrick, Justin Michael. 2006. *The Syntactic and Semantic Roots of Floating Quantification*. Diss. MIT.
- Flinn, Gallagher. 2017. "Georgian stem formants and nominalization." In *Proceedings of the Linguistic Society of America*, Vol. 2. Ed. Patrick Farrell. 47:1-13.
- Fong, Suzana. 2017a. "A raising analysis of accusative subjects in Mongolian." Ms., MIT. Available online at (<https://suzanafong.files.wordpress.com/2017/12/mongolian-accusative-subjects.pdf>).
- Fong, Suzana. 2017b. "A featural and edge-based analysis of hyper-raising." Ms., MIT.
- Fong, Suzana. 2018. "Featural definition of syntactic positions: Evidence from hyper-raising." *Proceedings of the Linguistic Society of America*, Vol. 3. Ed. Patrick Farrell. 2:1-15.
- Foster, Mary LeCron. 1969. *The Tarascan Language*. Berkeley: University of California.
- Fox, Danny. 1999. "Reconstruction, Binding Theory, and the Interpretation of Chains." *Linguistic Inquiry* 30.2: 157-196.
- Freidin, Robert. 2016. "Chomsky's linguistics: The goals of the generative enterprise." Review of *Chomsky's linguistics*, ed. Peter Graff and Coppe van Urk. *Language* 92.3: 671-723.
- Friedrich, Paul. 1970. "Shape in Grammar." *Language* 46.2, Part 1: 379-407.
- Giusti, Giuliana. 1990. "Floating Quantifiers, Scrambling, and Configurationality." *Linguistic Inquiry* 21.4: 633-41.
- Goodall, Grant. 1993. "SPEC of IP and SPEC of CP in Spanish *wh*-questions." In *Linguistic Perspectives on the Romance Languages: Selected Papers from the XXI Linguistic Symposium on Romance Languages*. Ed. William J. Ashby, Marianne Mithun, Giorgio Perissinotto, and Eduardo Raposo. Amsterdam: John Benjamins Publishing. 199-209.
- Goodall, Grant. 2001. "The EPP in Spanish." In *Objects and other Subjects: Grammatical Functions, Functional Categories and Configurationality*, eds. William D. Davies and Stanley Dubinsky. Dordrecht: Kluwer Academic Publishers. 193-223. Studies in Natural Language & Linguistic Theory.

Goto, Nobu. 2017a. “How to Label *There*-Constructions.” *English Literature, Regional Branches Combined Issue XII*, ed. Tohoku Branch of the English Literary Society of Japan, 1-12. The Tohoku Branch of the English Literary Society of Japan, Japan.

Goto, Nobu. 2017b. “Eliminating the Strong/Weak Parameter on T.” In *Proceedings of GLOW in Asia XI*, Vol. 2, ed. Michael Yoshitaka Erlewine. MIT Working Papers in Linguistics #85. Cambridge, MA: MIT Working Papers in Linguistics. 57-71.

Graf, Thomas. 2018. “Why movement comes for free once you have adjunction.” Ms., SUNY Stony Brook. Available online at <http://ling.auf.net/lingbuzz/003943>.

Gribanova, Vera. 2013. “Verb-stranding verb phrase ellipsis and the structure of the Russian verbal complex.” *Natural Language and Linguistic Theory* 31: 91-136.

Gribanova, Vera. 2018. “On the interaction between syntax and postsyntax in Uzbek (non-)verbal predicate formation.” Handout from Syntax & Semantics Circle (S-Circle), University of California, Santa Cruz.

Gribanova, Vera, and Boris Harizanov. To appear. “Whither head movement?” *Natural Language and Linguistic Theory*. Pre-publication version available at <http://ling.auf.net/lingbuzz/003960>.

Grohmann, Kleanthes K., John Drury, and Juan Carlos Castillo. 2000. “No More EPP.” In *WCCFL 19: Proceedings of the 19<sup>th</sup> West Coast Conference on Formal Linguistics*. Eds. Roger Billerey and Brook Danielle Lillehaugen. Somerville, MA: Cascadilla Press. 153-166.

Haider, Hubert. 2003. “V-clustering and clause union: Causes and effects.” In *Verb Constructions in German and Dutch*. Ed. Pieter A.M. Seuren and Gerard Kempen. Amsterdam: John Benjamins Publishing. 91-126.

Haider, Hubert. 2010. *The Syntax of German*. New York: Cambridge University Press.

Halpert, Claire, and Jochen Zeller. 2015. “Right dislocation and raising-to-object in Zulu.” *The Linguistic Review* 32.3: 475-513.

Halpert, Claire. 2016. “Raising Parameters.” In *Proceedings of WCCFL 33*. Ed. Kyeongmin Kim, Pocholo Umbal, Trevor Block, Queenie Chang, Tanie Cheng, Kelli Finney, Mara Katz, Sophie Nickel-Thompson, and Lisa Shorten. Somerville, MA: Cascadilla Proceedings Project. 186-195.

Halpert, Claire. 2018. “Raising, unphased.” *Natural Language and Linguistic Theory*. Online First.



- Hamilton, Michael David. 2015. "Phrase structure in Mi'gmaq: A configurational account of a 'non-configurational' language." *Lingua* 167: 19-40.
- Hammerly, Christopher. 2018. "A verb raising analysis of the Ojibwe VOS/VSO alternation." Handout from Syntax & Semantics Circle (S-Circle), University of California, Santa Cruz.
- Hankamer, Jorge. 2011. "Auxiliaries and Negation in English." *Representing Language: Essays in Honor of Judith Aissen*. Ed. Rodrigo Gutiérrez-Bravo, Line Mikkelsen, and Eric Potsdam. Santa Cruz, CA: Linguistics Research Center, 121-35.
- Harwood, William. 2015. "Being progressive is just a phase: celebrating the uniqueness of progressive aspect under a phase-based analysis." *Natural Language and Linguistic Theory* 33: 523-73.
- Haugen, Jason D. To appear. "Configurationality in Classical Nahuatl." In *Proceedings of the 20th Workshop on Structure and Constituency in Languages of the Americas*. Vancouver: UBCWPL. Available online at <http://ling.auf.net/lingbuzz/002453>.
- Harley, Heidi. 2008. "The bipartite structure of verbs cross-linguistically (or: Why Mary can't exhibit John her paintings)." In *Conferências do V Congresso Internacional da Associação Brasileira de Linguística*. Ed. Thaïs Cristófaró Silva and Heliana Mello. Belo Horizonte, Brazil: ABRALIN and FALE/UMFG. 45-84. Available online at <http://ling.auf.net/lingbuzz/000435>.
- Heck, Fabian, and Gereon Müller. 2007. "Extremely Local Optimization." In *Proceedings of WECOL 26*. Ed. Erin Bainbridge and Brian Agbayani. Fresno, CA: California State University. 170-183.
- Hedding, Andrew. 2017. "The Expression of Polarity in Somali." Ms., University of California, Santa Cruz.
- Henry, Alison. 2012. "Phase Edges, Quantifier Float and the Nature of (Micro-) Variation." *Iberia* 4.1: 23-39.
- Heim, Irene, and Angelika Kratzer. 1998. *Semantics in Generative Grammar*. Malden, MA: Blackwell. Blackwell Textbooks in Linguistics.
- Höhle, Tilman N. 1992. "Über Verum-Fokus im Deutschen." *Informationsstruktur und Grammatik*. Ed. Joachim Jacobs. Opladen: Westdeutscher Verlag. 112-41.

- Holmberg, Anders, Michelle Sheehan, and Jenneke van der Wal. 2016. "Movement from the double object construction is not fully symmetrical." Ms., Newcastle University/University of Cambridge, Anglia Ruskin University, and Harvard University. Available online at <http://ling.auf.net/lingbuzz/003075>.
- Hornstein, Norbert. 1999. "Movement and Control." *Linguistic Inquiry* 30.1: 69-96.
- Hornstein, Norbert, and Jairo Nunes. 2008. "Adjunction, Labeling, and Bare Phrase Structure." *Biolinguistics* 2.1: 57-86.
- Huddleston, Rodney, and Geoffrey K. Pullum, *et al.* *The Cambridge Grammar of the English Language (CGEL)*. Cambridge: Cambridge University Press.
- Ingason, Anton Karl, and Jim Wood. 2017. "Clause-Bounded Movement: Stylistic Fronting and Phase Theory." *Linguistic Inquiry* 48.3: 529-541.
- Janke, Vikki, and Ad Neeleman. 2012. "Ascending and Descending VPs in English." *Linguistic Inquiry* 43.2: 151-190.
- Jayaseelan, K.A. 2008. "Bare Phrase Structure and Specifier-less Syntax." *Biolinguistics* 2.1: 87-106.
- Johnson, Kyle. 1991. "Object Positions." *Natural Language and Linguistic Theory* 9: 577-636.
- Jurka, Johannes. 2013. "Subject islands in German revisited." *Experimental Syntax and Island Effects*. Ed. Jon Sprouse and Norbert Hornstein. Cambridge, UK: Cambridge University Press. 265-85.
- Kalivoda, Nick. 2015. "Distinguishing doubled clitics and pronominal arguments in Teotitlán del Valle Zapotec." Ms., University of California, Santa Cruz.
- Kalivoda, Nick, and Erik Zyman. 2018. "XP- and X<sup>0</sup>-movement in the Latin Verb: Evidence from Mirroring and Anti-Mirroring." Handout from the 92<sup>nd</sup> Annual Meeting of the Linguistic Society of America (LSA 2018), Salt Lake City, UT.
- Kirk, Allison. 2012. "Word Order and Information Structure in New Testament Greek." Diss. Universiteit Leiden.
- Kiss, Katalin É. 2002. "The EPP in a Topic-Prominent Language." In *Subjects, Expletives, and the EPP*. Ed. Peter Svenonius. New York: Oxford University Press. 107-124.

- Knochenhauer, Andrew G. 2016. "Unbounded Dependencies and Specifier Competition in Varieties of Spanish." Undergraduate senior thesis, University of California, Santa Cruz.
- Ko, Heejeong. 2007. "Asymmetries in Scrambling and Cyclic Linearization." *Linguistic Inquiry* 38.1: 49-83.
- Koopman, Hilda, and Dominique Sportiche. 1991. "The position of subjects." *Lingua* 85: 221-258.
- Kratzer, Angelika. 1996. "Severing the External Argument from Its Verb." *Phrase Structure and the Lexicon*. Ed. Johan Rooryck and Laurie Zaring. Vol. 33. Dordrecht: Kluwer Academic. 109-37. Studies in Natural Language and Linguistic Theory.
- Krejci, Bonnie, and Adam Tallman. 2015. "Chácobo Verb Splitting and the *vP* Shell." Paper presented at the 20<sup>th</sup> Workshop on Structure and Constituency in Languages of the Americas, Tucson, AZ.
- Laka, Itziar. 1990. *Negation in Syntax: On the Nature of Functional Categories and Projections*. Diss. MIT.
- Landau, Idan. 2007. "EPP Extensions." *Linguistic Inquiry* 38.3: 485-523.
- Larson, B. 2015. "Minimal search as a restriction on Merge." *Lingua* 156: 57-69.
- Larson, Richard K. 1988. "On the Double Object Construction." *Linguistic Inquiry* 19.3: 335-91.
- Larson, Richard K. 1990. "Double Objects Revisited: Reply to Jackendoff." *Linguistic Inquiry* 21.4: 589-632.
- Larson, Richard K. 2017. "On 'Dative Idioms' in English." *Linguistic Inquiry* 48.3: 389-426.
- Lasnik, Howard. 1995. "Case and Expletives Revisited: On Greed and Other Human Failings." *Linguistic Inquiry* 26: 615-33.
- Lasnik, Howard. 2003. "Last resort and attract F." In *Minimalist Investigations in Linguistic Theory*. London: Routledge. 22-41.
- Lebowski, Zach. 2016. "Ought and Negation." Ms., University of California, Santa Cruz.

- Legate, Julie Anne. 2003. "Some Interface Properties of the Phase." *Linguistic Inquiry* 34.3: 506-516.
- Legate, Julie Anne. 2014. *Voice and v: Lessons from Acehnese*. Cambridge, MA: MIT Press.
- Levin, Beth, and Malka Rappaport Hovav. 1995. *Unaccusativity: At the Syntax-Lexical Semantics Interface*. Cambridge, MA: MIT.
- Lizárraga Navarro, Glenda. 2013. "Clíticos de foco en purépecha." *Cuadernos de Lingüística de El Colegio de México* 1: 235-75. Available online at <http://cuadernoslinguistica.colmex.mx/images/PDF/Volumen1/LIZARRAGA.pdf>.
- Maling, Joan M. 1976. "Notes on Quantifier-Postposing." *Linguistic Inquiry* 7.4: 708-18.
- Marantz, Alec. 1997. "No Escape from Syntax: Don't Try Morphological Analysis in the Privacy of Your Own Lexicon." *University of Pennsylvania Working Papers in Linguistics* 4.2, Proceedings of the 21st Annual Penn Linguistics Colloquium. 201-225.
- Marantz, Alec. 2013. "Verbal argument structure: Events and participants." *Lingua* 130: 152-168.
- Martins, Ana Maria, and Jairo Nunes. 2010. "Apparent Hyper-raising in Brazilian Portuguese: Agreement with Topics across a Finite CP." In *The Complementizer Phase: Subjects and Operators*. Ed. E. Phoevos Panagiotidis. Oxford: Oxford University Press. 143-163.
- McCloskey, James. 1997. "Subjecthood and subject positions." In *Elements of Grammar: A Handbook of Generative Syntax*. Ed. Liliane Haegeman. Dordrecht: Kluwer. 197-235.
- McCloskey, James. 2000. "Quantifier Float and *Wh*-Movement in an Irish English." *Linguistic Inquiry* 31.1: 57-84.
- McCloskey, James. 2001. "The morphosyntax of WH-extraction in Irish." *Journal of Linguistics* 37.1: 67-100.
- McCloskey, Jim. 2017. "Object positions (in Irish)." In *A Schrift to Fest Kyle Johnson*. Eds. Nicholas LaCara, Keir Moulton, and Anne-Michelle Tessier. Available online at [http://scholarworks.umass.edu/linguist\\_oapubs/1/](http://scholarworks.umass.edu/linguist_oapubs/1/).

- McFadden, Thomas. 2003. "Adventures in Resolving Redundancy: Case vs. the EPP." *University of Pennsylvania Working Papers in Linguistics* 9.1: *Proceedings of the 26th Annual Penn Linguistics Colloquium*. 137-150.
- McGarry, Lauren. 2016. "VS word order and presentational constructions in Russian." Ms., University of California, Santa Cruz.
- Medina Pérez, Alberto. 2006. *Guía Lingüística del Idioma P'urhépecha*. Morelia, Michoacán, Mexico: Universidad Michoacana de San Nicolás de Hidalgo.
- Mendoza, Martha. 2007. "Derivational Resources in P'urhepecha: Morphological Complexity and Verb Formation." *Acta Linguistica Hungarica* 54.2: 157-72.
- Merchant, Jason. 1996. "Object scrambling and quantifier float in German." *Proceedings of NELS 26*. Ed. Kiyomi Kusumoto. Graduate Linguistic Student Association, UMass Amherst. 179-193.
- Merchant, Jason. 2018. "Roots don't select, categorial heads do: lexical-selection of PPs may vary by category." Ms., University of Chicago. Available online at (<http://ling.auf.net/lingbuzz/003930>).
- Mitchell, Erika. 2006. "The morpho-syntax of negation and the positions of NegP in the Finno-Ugric languages." *Lingua* 116: 228-244.
- Miyagawa, Shigeru, and Takae Tsujioka. 2004. "Argument Structure and Ditransitive Verbs in Japanese." *Journal of East Asian Linguistics* 13: 1-38.
- Müller, Gereon. 2017. "Structure removal: An argument for feature-driven Merge." *Glossa* 2(1): 28. 1-35.
- Nevins, Andrew. 2004. "Derivations without the Activity Condition." In *Perspectives on Phases: MIT Working Papers in Linguistics* 49, ed. Martha McGinnis and Norvin Richards. Cambridge, MA: MITWPL. 283-306.
- Newman, Elise. 2016. "Shanghainese: the Case of the Lonely DP." Undergraduate thesis, MIT.
- Nunes, Jairo. 2016. "On the locus and licensing of edge features." Ms., University of São Paulo. Available online at ([http://www.researchgate.net/publication/310156524\\_On\\_the\\_locus\\_and\\_licensing\\_of\\_edge\\_features](http://www.researchgate.net/publication/310156524_On_the_locus_and_licensing_of_edge_features)).

- Obata, Miki, and Samuel David Epstein. 2008. "Deducing Improper Movement from Phase-Based C-to-T Phi Transfer: Feature-Splitting Internal Merge." In *Proceedings of WCCFL 27*. Ed. Natasha Abner and Jason Bishop. Somerville, MA: Cascadilla Proceedings Project. 353-360.
- Ostrove, Jason. 2015. "Allomorphy and the Irish Verbal Complex." Ms., University of California, Santa Cruz. Available online at <https://people.ucsc.edu/~jostrove/QP1.pdf>.
- Ostrove, Jason. 2016a. "Non-Uniform Case Assignment in Scottish Gaelic." Handout from Arizona Linguistics Circle, University of Arizona, Tucson. Available online at <http://people.ucsc.edu/~jostrove/alc10.pdf>.
- Ostrove, Jason. 2016b. "Predicate Complexes in San Martín Peras Mixtec." Handout from Morphology Reading Group (MRG), University of California, Santa Cruz.
- Ostrove, Jason. 2017a. "Getting the Pieces Together: Predication and Wordhood in San Martín Peras Mixtec." Ms., University of California, Santa Cruz.
- Ostrove, Jason. 2017b. "WH-Movement in San Martín Peras Mixtec." Handout from the Workshop on the Languages of Meso-America (WLMA), University of California, Santa Cruz.
- Ostrove, Jason. 2018. "Stretching, spanning, and linear adjacency in Vocabulary Insertion." *Natural Language and Linguistic Theory*. Online First.
- Ostrove, Jason. Submitted. "Linear adjacency and case morphology in Scottish Gaelic." Ms., University of California, Santa Cruz.
- Ott, Dennis. 2010. "Grammaticality, interfaces, and UG." In *Exploring Crash-Proof Grammars*, ed. Michael Putnam. Amsterdam: John Benjamins. 89-104.
- Ott, Dennis. 2015. "Symmetric Merge and Local Instability: Evidence from Split Topics." *Syntax* 18: 157-200.
- Perlmutter, David M. 1978. "Impersonal Passives and the Unaccusative Hypothesis." In *Proceedings of the Fourth Annual Meeting of the Berkeley Linguistics Society*. Berkeley Linguistics Society, University of California, Berkeley. 157-189.
- Pesetsky, David. 2000. *Phrasal Movement and Its Kin*. Cambridge, MA: MIT Press.
- Petersen, Carolina, and Arhonto Terzi. To appear. "Hyperraising and locality: a view from Brazilian Portuguese and Greek." *Proceedings of CLS 50*.

- Phillips, Colin. 2003. "Linear Order and Constituency." *Linguistic Inquiry* 34.1: 37-90.
- Pietraszko, Asia. 2018. "The distribution of  $\phi$ -probes in the inflectional structure." In *Proceedings of the Linguistic Society of America*, Vol. 3. Ed. Patrick Farrell. 59:1-15.
- Pollock, Jean-Yves. 1989. "Verb Movement, Universal Grammar, and the Structure of IP." *Linguistic Inquiry* 20.3: 365-424.
- Poole, Ethan. 2016. "Deconstructing subjecthood." Ms., UMass Amherst. Available online at <http://ling.auf.net/lingbuzz/003197>.
- Postal, Paul M. 1974. *On Raising*. Cambridge, MA: MIT Press.
- Richards, Marc. 2017. "Problems of 'Problems of Projection': Breaking a conceptual tie." Position paper presented at Generative Syntax 2017: Questions, Crossroads, and Challenges. Universitat Autònoma de Barcelona, Spain. Available online at <http://gensyn17.wixsite.com/gensyn17/discussion>.
- Richards, Norvin. 1997. *What Moves Where When in Which Language?* Diss. MIT.
- Rizzi, Luigi. 1990. *Relativized Minimality*. Cambridge, MA: MIT Press.
- Rizzi, Luigi. 1982. *Issues in Italian Syntax*. Dordrecht: Foris.
- Rizzi, Luigi. 1997. "The Fine Structure of the Left Periphery." *Elements of Grammar: A Handbook of Generative Syntax*. Ed. Liliane Haegeman. Dordrecht: Kluwer. 281-337.
- Rizzi, Luigi. 2001. "Relativized Minimality Effects." In *The Handbook of Contemporary Syntactic Theory*, ed. Mark R. Baltin and Chris Collins. Oxford: Wiley-Blackwell. 89-110.
- Rizzi, Luigi. 2015. "Notes on labeling and subject positions." In *Structures, Strategies and Beyond: Studies in honour of Adriana Belletti*, eds. Elisa Di Domenico, Cornelia Hamann, and Simona Matteini. Amsterdam/Philadelphia: John Benjamins. 17-46.
- Salzmann, Martin. To appear. "Prolepsis." In *The Companion to Syntax, 2nd Edition*. Ed. Martin Everaert and Henk van Riemsdijk. Wiley-Blackwell.
- Safir, Ken. To appear. "The A-/A'-distinction as an epiphenomenon." *Linguistic Inquiry*. Manuscript available at <http://ling.auf.net/lingbuzz/002798>.
- Samko, Bern. 2016. *Syntax and Information Structure: The Grammar of English Inversions*. Diss. University of California, Santa Cruz.

- Servidio, Emilio. 2009. "A puzzle on auxiliary omission and focalization in English: evidence for cartography." *Snippets* 19: 21-22.
- Shima, Etsuro. 2009. "A Preference for Move over Merge." *Linguistic Inquiry* 31.2: 375-385.
- Shlonsky, Ur. 1991. "Quantifiers as functional heads: A study of Quantifier Float in Hebrew." *Lingua* 84: 159-80.
- Smith, Ryan Walter. 2015. "A Labeling Approach to Constraints on Coordinate Structure Syntax." Ms., University of Arizona. Available online at <http://ryanwaltersmith.wixsite.com/home/papers>.
- Sportiche, Dominique. 1988. "A Theory of Floating Quantifiers and Its Corollaries for Constituent Structure." *Linguistic Inquiry* 19.3: 425-449.
- Svenonius, Peter. 2002. "Subject Positions and the Placement of Adverbials." In *Subjects, Expletives, and the EPP*. Ed. Peter Svenonius. New York: Oxford University Press. 201-242.
- Stockwell, Richard. 2016. "Labelling in Syntax." *Cambridge Occasional Papers in Linguistics* 9.5: 130-155. Available online at <http://www.ling.cam.ac.uk/COFIL/papers/9-05-stockwell.pdf>.
- Takano, Yuji. 2003. "How Antisymmetric is Syntax?" *Linguistic Inquiry* 34.3: 516-526.
- Tanaka, Hidekazu. 2002. "Raising to Object out of CP." *Linguistic Inquiry* 33.4: 637-652.
- Tescari Neto, Aquiles. 2012. "Floating Quantifiers and Higher Adverbs as Scope-Inducing Elements." Talk handout. 24 September. Università Ca' Foscari, Venice.
- Tescari Neto, Aquiles. 2013. *On Verb Movement in Brazilian Portuguese: A Cartographic Study*. Diss. Università Ca' Foscari Venezia.
- Torrego, Esther. 1996. "On Quantifier Float in Control Clauses." *Linguistic Inquiry* 27.1: 111-126.
- Travis, Lisa. 1984. *Parameters and Effects of Word Order Variation*. Diss. MIT.
- Tucker, Matthew Alan. 2013. *Building Verbs in Maltese*. Diss. University of California, Santa Cruz.



- van Urk, Coppe. 2015. *A uniform syntax for phrasal movement: A case study of Dinka Bor*. Diss. MIT.
- van Urk, Coppe, and Norvin Richards. 2015. "Two Components of Long-Distance Extraction: Successive Cyclicity in Dinka." *Linguistic Inquiry* 46.1: 113-155.
- Vázquez-Rojas Maldonado, Violeta. 2011. "Case Marking and Semantic Incorporation in Tarascan." *Proceedings of SULA 5: Semantics of Under-Represented Languages in the Americas*. Ed. Suzi Lima. UMOP (UMass Occasional Papers in Linguistics). Vol. 41.
- Vázquez Rojas Maldonado, Violeta. 2012. *The Syntax and Semantics of Purépecha Noun Phrases and the Mass/Count Distinction*. Diss. NYU.
- Vázquez Rojas Maldonado, Violeta. 2013. "Estudios descriptivos del purépecha. Estudio introductorio." *Cuadernos de lingüística de El Colegio de México* 1: 7-25.
- Vergnaud, Jean-Roger. 1977 [2008]. "Letter to Howard Lasnik and Noam Chomsky on 'Filters and Control,' April 17, 1977." *Foundational Issues in Linguistic Theory: Essays in Honor of Jean-Roger Vergnaud*. Ed. Robert Freidin, Carlos P. Otero, and Maria Luisa Zubizarreta. Cambridge, MA: MIT Press. 3-15.
- Villavicencio Zarza, Frida. 2006. *P'orhépecha kaso sirátahenkwa: desarrollo del sistema de casos del purépecha*. Mexico City: Centro de Investigaciones y Estudios Superiores en Antropología Social (CIESAS): El Colegio de México (Publicaciones de la Casa Chata).
- Vincent, Jake. 2017. "D-raising in Chamorro relative clauses and other A' constructions." M.A. thesis, University of California, Santa Cruz. Available online at [http://people.ucsc.edu/~jwvincen/documents/jake\\_vincent\\_ma.pdf](http://people.ucsc.edu/~jwvincen/documents/jake_vincent_ma.pdf).
- Vincent, Jake. 2018. "Sentential negation and negative concord licensing in Chamorro." Ms., University of California, Santa Cruz.
- Wares, Alan C. 1974. "Tarascan Verb Inflection." SIL-Mexico Workpapers 1: 93-100. *Ethnologue, Languages of the World*. SIL International. Web. [http://www.ethnologue.com/show\\_work.asp?id=12626](http://www.ethnologue.com/show_work.asp?id=12626).
- Werthen, Lydia. 2018. "Wh-Continuation: A neglected puzzle." Poster presented at Linguistics at Santa Cruz (LASC) 2018, University of California, Santa Cruz.
- Wexler, Kenneth and Peter Culicover. 1980. *Formal Principles of Language Acquisition*. Cambridge, MA: MIT Press.

Yatabe, Shuichi. 2010. "Association of floated quantifiers with expressions other than the local grammatical subjects in John Updike's *Rabbit, Run*." *Snippets* 22: 14-15. Available online at <http://www.ledonline.it/snippets/allegati/snippets22005.pdf>.

Zanuttini, Raffaella. 1997. *Negation and Clausal Structure: A Comparative Study of Romance Languages*. New York: Oxford University Press.

Zubizarreta, Maria Luisa. 1998. *Prosody, Focus, and Word Order*. Cambridge, MA: MIT Press.

Zyman, Erik. 2012. *Two Investigations of Adverbs and Clause Structure in English*. Senior thesis, Princeton University. Available online at [http://people.ucsc.edu/~ezyman/adverbs\\_clause\\_structure.pdf](http://people.ucsc.edu/~ezyman/adverbs_clause_structure.pdf).