

# Lawrence Berkeley National Laboratory

## LBL Publications

### Title

The Electron-Ring Accelerator Program at Berkeley

### Permalink

<https://escholarship.org/uc/item/5qt7t547>

### Authors

Peterson, J M

Chupp, W W

Garren, A A

et al.

### Publication Date

1970-10-01

### Copyright Information

This work is made available under the terms of a Creative Commons Attribution License, available at <https://creativecommons.org/licenses/by/4.0/>

Presented at the 2nd National  
Conference on Particle Accelerators,  
Moscow, USSR (November 11-18, 1970)

UCRL-20150  
Preprint *e.2*

LAWRENCE  
RADIATION LABORATORY

LIBRARY AND  
DOCUMENTS SECTION

THE ELECTRON-RING ACCELERATOR PROGRAM AT  
BERKELEY

J. M. Peterson, W. W. Chupp, A. A. Garren,  
D. Keefe, G. R. Lambertson, L. J. Laslett,  
W. A. Perkins, and A. M. Sessler

October 20, 1970

AEC Contract No. W-7405-eng-48

**TWO-WEEK LOAN COPY**

*This is a Library Circulating Copy  
which may be borrowed for two weeks.  
For a personal retention copy, call  
Tech. Info. Division, Ext. 5545*

*26*  
LAWRENCE RADIATION LABORATORY  
UNIVERSITY of CALIFORNIA BERKELEY *e.2*

UCRL-20150

## **DISCLAIMER**

This document was prepared as an account of work sponsored by the United States Government. While this document is believed to contain correct information, neither the United States Government nor any agency thereof, nor the Regents of the University of California, nor any of their employees, makes any warranty, express or implied, or assumes any legal responsibility for the accuracy, completeness, or usefulness of any information, apparatus, product, or process disclosed, or represents that its use would not infringe privately owned rights. Reference herein to any specific commercial product, process, or service by its trade name, trademark, manufacturer, or otherwise, does not necessarily constitute or imply its endorsement, recommendation, or favoring by the United States Government or any agency thereof, or the Regents of the University of California. The views and opinions of authors expressed herein do not necessarily state or reflect those of the United States Government or any agency thereof or the Regents of the University of California.

The Electron-Ring Accelerator Program at Berkeley\*

J.M. Peterson, W.W. Chupp, A.A. Garren, D. Keefe,  
G.R. Lambertson, L.J. Laslett, W.A. Perkins  
and A.M. Sessler

20 October 1970

Lawrence Radiation Laboratory  
University of California  
Berkeley, California

I Introduction

Early in 1968 a research group was set up at the Lawrence Radiation Laboratory to investigate the exciting new concept of accelerating ions by means of relativistic electron rings, which had been introduced and developed by Veksler, Sarantsev, and other workers at Dubna.<sup>1</sup> The initial work of our group was reported at the first USSR National Conference on Particle Accelerators in 1968. In this report I shall review the subsequent progress and the present program.

II Experiment for Forming Intense Rings

The aim of our first major experiment was simply to form and compress electron rings of high intensity. We were fortunate in

---

\* Research supported by the U.S. Atomic Energy Commission

<sup>1</sup> V.I. Veksler, V.P. Sarantsev, A.G. Bonch-Osmolovsky, G.V. Dolbilov, G.A. Ivanov, I.N. Ivanov, M.L. Iovnovitch, I.V. Kozhukhov, S.B. Kusnetsov, V.G. Makhan'kov, E.A. Perel'shtein, V.P. Rashevsky, K.A. Reshetnikova, N.B. Rubin, S.B. Rubin, P.I. Ryl'tsev, O.I. Yarkovoy, Cambridge Electron Accelerator Report No. CEAL-2000, 1967, p. 289.

having available a high-intensity source of relativistic electrons, namely the Astron 3.5 MeV, 400 ampere linear induction accelerator at LRL-Livermore.

The apparatus in this experiment,<sup>2</sup> called Compressor 2, is shown in the first figure, in which both radial and axial cross sections are illustrated. A "weak-focussing" magnetic guide field is provided by three pairs of pulsed coils situated outside a ceramic vacuum chamber. The three pairs of magnet coils are pulsed sequentially, the outermost pair serving to accept the 3.5-MeV injected beam at a radius of 19 cm and to accelerate and compress it to a radius at which the next set of coils can continue the compression, progressing in this manner until the beam reaches a radius of 3.5 cm and an energy of 18 MeV. The second figure illustrates the time behavior of the ring radius, the kinetic energy, the magnetic field, and the magnetic index,  $n \left( = \frac{R}{B_z} \frac{dB_z}{dR} \right)$ , at the position of the ring during the 500 microsecond compression cycle.

The magnetic index,  $n$ , was the critical parameter in this experiment because of resonant beam instabilities. Generally, a beam can become unstable when its radial and axial betatron frequencies,  $Q_r$  and  $Q_z$  (betatron oscillations per revolution), have an integral relationship  $aQ_r + bQ_z = c$ , where  $a$ ,  $b$ , and  $c$  are small integers and are related to the shape of the magnetic perturbation that drives the instability. Since the betatron frequencies  $Q_r$  and  $Q_z$  are determined by  $n$ , namely  $Q_r^2 = 1-n$  and  $Q_z^2 = n$ , it is clear that at certain values of  $n$  (e.g.,  $5/9$ ,  $4/9$ ,  $9/25$ ,  $1/4$ ,  $1/5$ ,  $1/9$ , ...) beam resonances

<sup>2</sup> D. Keefe, G.R. Lambertson, L.J. Laslett, W.A. Perkins, J.M. Peterson, A.M. Sessler, R.W. Allison, Jr., W.W. Chupp, A.U. Luccio, and J.B. Rechen, Phys. Rev. Letters, 22, 558 (1969).

are possible and can cause large growth in beam size if the right magnetic perturbation or non-linearity is present and if the resonance is crossed sufficiently slowly. In the Compressor 2 experiment it was found necessary to modify the n-trajectory of just the initial, large-radius portion of the compression cycle (where the magnetic perturbations are the largest) before a satisfactory compression could be achieved. After this modification the captured beam was compressed essentially without loss. The intensity of the ring was about  $4 \times 10^{12}$  electrons and seemed to be limited by the injector rather than by any mechanism in the compressor. We observed no important intensity effects, aside from a helpful self-trapping mechanism, which occurred at incident beam currents greater than about 50 or 75 amperes. Furthermore, the compressed ring was stable for several milliseconds, being limited only by the decay of the magnetic field, which eventually brought it to the condition  $Q_r = 1$ , at which point the beam became unstable and was lost. The effects of ion focussing also were observed. By means of a fast acting valve, a short puff of gas was admitted to the chamber, which served to load the ring with ions. It was very apparent that the ion loading brought the beam to the  $Q_r = 1$  resonance at an earlier time.

At a compression energy of 18 MeV the synchrotron light from an electron ring is very bright to the eye and can be photographed to show the spatial distribution within the ring. Figure 3 shows such a synchrotron-light photograph. Such measurements showed that the density distribution was Gaussian and gave minor ring radii of 1.6 and 2.3 mm

(rms), which were in agreement with independent probe measurements. From the intensity and the geometrical data we calculate a peak electric field of 12 MV per meter, which already is a level of field strength that begins to be of interest for accelerator application. Furthermore, we were encouraged to find that such an intensity could be achieved without great difficulty and without barriers to higher intensities becoming apparent.

### III Experiment for Accelerating Ions

Our next effort was an experiment for accelerating an electron ring loaded with ions. In this experiment we wanted to form similar rings, load them with a few per cent of hydrogen ions, and accelerate them to a few MeV by magnetic acceleration over a distance of half a meter. The apparatus for this experiment, called Compressor 3, is illustrated in Figure 4. The design here differed from that of Compressor 2 in two respects: (1) coil 3 was developed into a solenoid, the long side of which was the accelerating region for the ring and (2) coil 1 was elaborated to minimize the variation of the magnetic index  $n$  over the first few centimeters of compression.

Our greatest concern in the design of Compressor 3 was the problem of extracting the compressed ring from its magnetic well and starting it down the accelerating solenoid, where the magnetic field is essentially constant. Additional focussing must be supplied here to avoid both (1) axial spreading of the ring ( $Q_z = 0$ ) and (2) radial blow-up as  $Q_r$  approaches 1.0. Positive focussing in each direction is supplied by

the positive ions being accelerated, but these forces are relatively weak for ion loading of only a few per cent. Image focussing by a "squirrel-cage" conducting cylinder<sup>3</sup> is more effective and also more satisfactory in that it raises the axial tune  $Q_z$  but lowers the radial tune  $Q_r$ , thus avoiding the  $Q_r = 1$  resonance.

This acceleration experiment was not a success because we could not form satisfactory rings in Compressor 3. As a result we did not get a chance even to try acceleration of a loaded ring of good quality in the period available to us at the Astron accelerator. We had two difficulties, the first of which was a pronounced negative-mass effect. As the intensity of the injected beam was increased to, say, 150 amperes, the radial width of the ring increased corresponding to an energy spread of about 10%, which greatly diluted the electron density in the ring. This large negative-mass effect was due to the unexpectedly narrow energy spread in the beam from the Astron injector, which had been completely rebuilt in the period between our two experiments. Whereas the instantaneous energy spread of the injector had been about 0.5% in the Compressor 2 experiment, the new injector had no more than 0.2%. The spread was measured by using the Compressor 3 as a magnetic energy analyzer. Since the negative-mass threshold varies as  $(\Delta p/p)^2$ , this measurement indicated that the Compressor-3 situation had a much smaller threshold for this instability.

Our second difficulty in the Compressor-3 experiment was an axial blow-up and loss of most of the beam because of single-particle resonances. The principal loss occurred at  $n = 0.5$  (where  $Q_r - Q_z = 0$ ).

---

<sup>3</sup> G.V. Dolbilov, et al, Proceedings of the VII International Conference on High Energy Accelerators, Yerevan, USSR, 1969 (to be published).



The coil system was flexible enough to permit injection below  $n = 0.5$ , but when this was tried, resonances at  $n = 9/25$  and  $n = 1/4$  also caused excessive beam loss. These resonances were present also in Compressor 2 but were less troublesome there because the shape of magnetic field was different.

#### IV Present Program

These instabilities encountered in the Compressor 3 experiment are now understood well enough that we have designed with some confidence modifications for avoiding these troubles. For avoiding the negative-mass instability we shall first try a tapered foil in the incident beam line to provide sufficient instantaneous energy spread. For avoiding the single-particle resonance instabilities, we have shaped the magnetic field so as to reduce the second and third radial derivatives of the magnetic field ( $d^2B_z/dR^2$  and  $d^3B_z/dR^3$ ), which drive the  $n = 0.5$  resonance, and similarly we have reduced the azimuthal magnetic perturbations that drive the  $n = 9/25$  and  $n = 1/4$  resonances. We are testing these design features in a new compressor experiment that has just started. We plan to test the extraction and acceleration of electron rings loaded with ions later this winter.

#### V New Injector Facility

In order to carry out our ERA developmental program in a more systematic and orderly fashion, we have been building in Berkeley over

the past several months a new injector accelerator. It is a linear induction accelerator, similar in principle to the Astron injector except that it has a shorter pulse length (30 to 40 nanoseconds) and lower repetition rate (1 Hertz), which permit a simpler and less expensive design. The energy will be 4 MeV, and the nominal peak current is 500 amperes. The design is modular, consisting of 17 induction cavities driven by 40-nanosecond pulses from Blumlein pulse-forming lines. Each cavity provides 0.25 MV across its gap. Figure 5 shows a typical cavity. The induction cores here are ferrite rather than tape-wound metal ribbon used heretofore. These cavities serve not only to make up an injector accelerator but also as models of the type of cavities that we visualize as useful for electric acceleration of electron rings in a high-energy proton accelerator. I shall speak more about this concept later.

The electron gun of our new accelerator, shown in Figure 6, consists of five of these cavities stacked close together and coupled by means of a central conducting rod that terminates at the fifth cavity and carries the emitting cathode. The cathode voltage thus is the sum of the voltages of the five cavities, which is 1.25 MV.

This accelerator has now been assembled and successfully tested up to the 2 MeV point, and it is presently being used in compressor experiments. Only field-emission types of cathodes have been used thus far, although the geometry of the electron gun is compatible with the use of thermionic cathodes as well. Field-emission types have been used initially because of their greater simplicity, and thus far they seem satisfactory.

Consistent peak currents of 1000 amperes or more are easily obtained, and the cathode lifetime is acceptable (greater than  $2 \times 10^5$  pulses). Furthermore, the brightness of the beam is adequate for electron-ring formation. The instantaneous energy spread has not yet been measured precisely; it is known only to be less than 0.5%.

The physical layout of this injector and the experimental facility is shown in Figure 7. Apparatus for the formation and acceleration of electron rings is being prepared for installation in the experimental hall at the end of the injector enclosure.

#### VI Future Possibilities for ERA

For the future we are still optimistic that the electron-ring accelerator will prove to be successful, both for medium-energy heavy-ion acceleration and for high-energy proton accelerators. We have been greatly encouraged by the results of the electron-ring group under Sarantsev<sup>4</sup> at Dubna. Our own analyses of the technical and economic aspects of the problem have also been encouraging.

We recently made a study of the feasibility of a 60 to 100 GeV proton-type electron-ring accelerator.<sup>5,6</sup> This machine consisted of a compressor, a 320-meter section of electric acceleration, and a final 160-meter section of magnetic-expansion acceleration. Figure 8 illustrates the two types of accelerating sections.

The electric acceleration column consists of a series of linear

---

<sup>4</sup> V.P. Sarantsev, Proceedings of the VII International Conference on High Energy Accelerators, Yerevan, USSR, 1969 (to be published).

<sup>5</sup> ERA Group at LRL, "Conceptual Studies for New Technology Proton Accelerators (50-100 GeV)", LRL Internal Report ERAN-108, April 1970 (unpublished).

<sup>6</sup> C. Bovet and C. Pellegrini, "A Study on the Choice of Parameters for a High Energy Electron Ring Accelerator", LRL Report UCRL-19892, June 1970.

induction cavities like those in our injection accelerator shown in a previous slide. The average external accelerating field supplied by the cavities is 5 MV per meter. The solenoidal guide field of 30 kg is provided by superconducting coils that are interspersed between the cavities. Although the radius of the electron ring is only of the order of 2 or 3 cm, a relatively large bore radius of 19 cm is provided in the electric cavities to keep down the electromagnetic energy loss due to the interaction between the electrons and the accelerating structure. Since this electromagnetic loss increases as the square of the number of electrons in the ring, this effect limits the number of electrons, the limit in our situation being 1 to  $3 \times 10^{13}$  electrons per ring. It also prevents the use of a focussing image cylinder, which in an electric column could at best occur only intermittently and thus would greatly increase the electromagnetic loss. Another result of this electromagnetic loss is an axial defocussing effect on the electrons in the ring; however, a recent study<sup>7</sup> has shown that this effect is small and does not impose an important constraint on the parameters or performance of an electron-ring accelerator.

In this example, the electron ring has a maximum electric field of 500 MeV/meter and is loaded typically with 1/2% of protons. The protons gain energy from electric acceleration at the average rate of 125 MeV/meter, thus gaining a total of about 40 GeV in the 320 meter length of the electric column. In the electric column the average accelerating rate for the protons is maintained at only one quarter of

---

<sup>7</sup> E. Keil, C. Pellegrini, and A.M. Sessler, "Diffraction Radiation Defocussing of an Electron Ring", LRL Report UCRL-20069, Oct. 1970.

the maximum electric field at the ring in order that polarization effects within the ring not become severe. Since in the electric column the integrity of the electron-ion ring is maintained only through ion focussing, there is the great danger that the system can become unstable if the centers of the positive and negative charges become too much separated. A self-consistent solution of this problem has not yet been found.

The last section of the accelerator, a magnetic-acceleration column 150 meters in length, is simply a slightly tapered, superconducting solenoid. In it the proton energy increases by a factor of about 2 entering at 40 GeV and reaching about 80 GeV at the end. In this magnetic column the protons are allowed to gain energy at a rate of one half the maximum electric field of the ring (rather than  $1/4$  as in the electric column) because here the focussing of the ring system is dominated by the forces from an image cylinder, so that polarization of the ions and electrons does not threaten the integrity of the ring.

The constraints put on the parameters of the electron rings in this study were quite severe. In addition to the radiation-loss limitation imposed by the ring-cavity interaction already mentioned, ring stability was required throughout the whole process of ring formation and acceleration. The number of electrons in the ring was kept below the thresholds for the negative-mass instability, the resistive-wall instability, and the transverse incoherent space-charge effect. With all these constraints, plus that of achieving 80-GeV protons in a total length of 480 meters, the range of possible compressor

designs is quite limited. One interesting solution to the problem of compressor design, suggested by Pellegrini,<sup>8</sup> utilizes shrinking of the ring dimensions by the mechanism of synchrotron radiation. This radiation-compression process has the disadvantage of requiring a radiation period on the order of milliseconds. However, other more straightforward compressor designs also are possible. One typical set of compressor parameters is

Injection energy	8 MeV
Injection radius	50 or 100 cm
Final energy	12 MeV
Final Radius	2 or 3 cm
Final minor radius	0.1 cm
Momentum spread, initial	0.4 to 1.0%
Momentum spread, final	0.7 to 1.0%
Number of electrons	1.5 to $3 \times 10^{13}$

Although in my talk I have characterized this electron-ring accelerator as an 80-GeV machine, one should realize that in this type of device the actual output energy is a strong function of the amount of ion loading and of the detailed properties of the electron ring. For a fixed set of hardware in the electric and magnetic columns, the output energy could be 100 GeV at an average intensity of  $5 \times 10^{12}$

---

<sup>8</sup> C. Pellegrini, "Synchrotron Radiation and Ring Formation in the Electron Ring Accelerator", LRL Report UCRL-19815, May 1970.

protons per second (assuming a 100-Hz repetition rate) but is limited to 60 GeV at an intensity of  $2 \times 10^{13}$  protons per second (assuming optimum operation in each case).

The cost of such an 80-GeV accelerator also was estimated, based on our experience in building superconducting magnets, linear induction accelerators, and conventional accelerator components. The result of this cost study was the estimate that, for proton machines in the high-energy range, an electron-ring accelerator could be built at a cost that is considerably less than that for a conventional synchrotron.

Heavy-ion acceleration by electron rings is, of course, considerably simpler than high-energy proton acceleration. A heavy-ion accelerator would consist of a compressor and a short magnetic-expansion column and thus would be small, relatively simple, and not limited by the electromagnetic loss encountered in an electric-acceleration column.

We conclude from these considerations that electron-ring technology shows great promise for the future of nuclear physics and that its development should be pursued with vigor.

Many people have participated in this ERA program at LRL Berkeley. Among them are:

E.J. Lofgren	A. Entis	E.C. Hartwig	W.W. Salsig
J.B. Rechen	L. Smith	A. Faltens	R.T. Avery
R.W. Allison	A.U. Luccio	H.D. Lancaster	H.P. Hernandez
D. George	C. Pellegrini	W.R. Baker	J.R. Meneghetti
	C. Bovet	F. Voelker	
	A. Nakach	R.G. Nemetz	
	J.M. Hauptman	C.D. Pike	

Figure Captions

- Figure 1 - Cross-section views of the Compressor 2 apparatus.
- Figure 2 - Variation of parameters during the compression cycle. Upper curves: radius of the ring and electron kinetic energy. Lower curves: the magnetic index,  $n$  (right ordinate), and the magnetic field at the ring (left ordinate).
- Figure 3 - Observations of the electron ring. (a) Microwave and x-ray signals when the ring was destroyed by a resonance about 40 microseconds after injection. (b) Similar traces after the  $n$ -trajectory was modified to avoid resonances when the ring was at the larger radii. The beam loss at 6 milliseconds is probably due to a  $Q_r = 1$  resonance encountered because of the long time decay of the magnetic field. (c) Photograph of the synchrotron light from a compressed ring. Exposure time was 0.5 microsecond. The structure within the image of the spot is due to structure within the camera.
- Figure 4 - Cross section view of the Compressor 3 apparatus.
- Figure 5 - Cross section view of a cavity of the linear induction accelerator.
- Figure 6 - Drawing of the five-cavity electron gun.
- Figure 7 - Drawing of the linear induction accelerator and electron-ring experimental area.
- Figure 8 - Drawings of sections of the electric-acceleration column and of the magnetic-acceleration column.



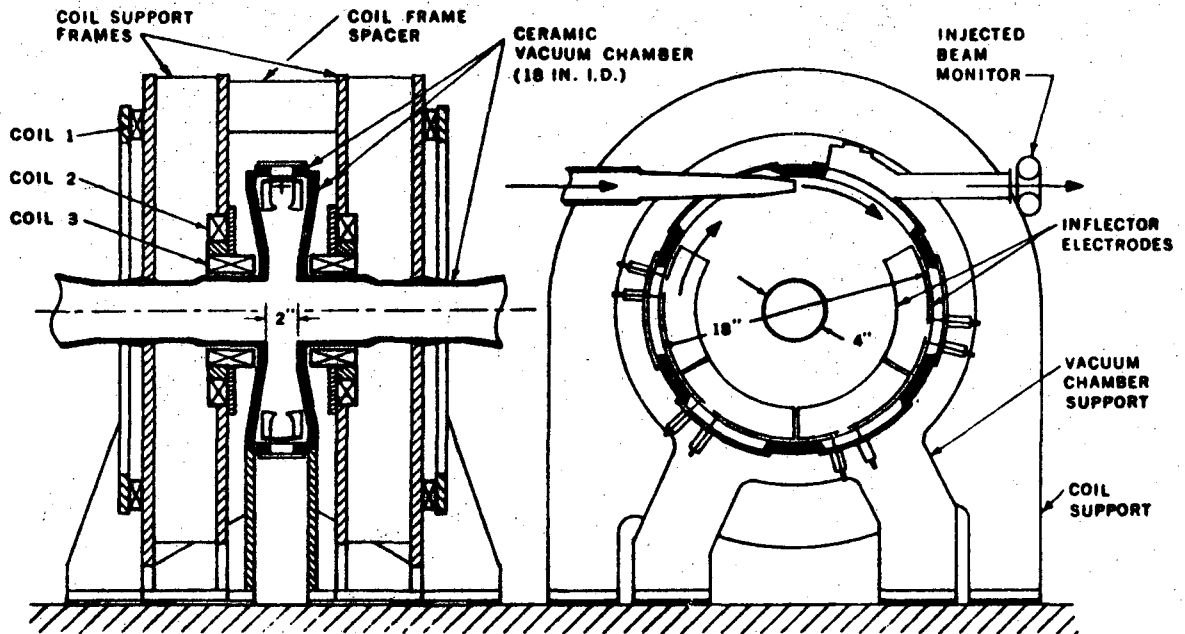

ELECTRON RING ACCELERATOR - COMPRESSOR II

IBL 689-4921

Figure 1

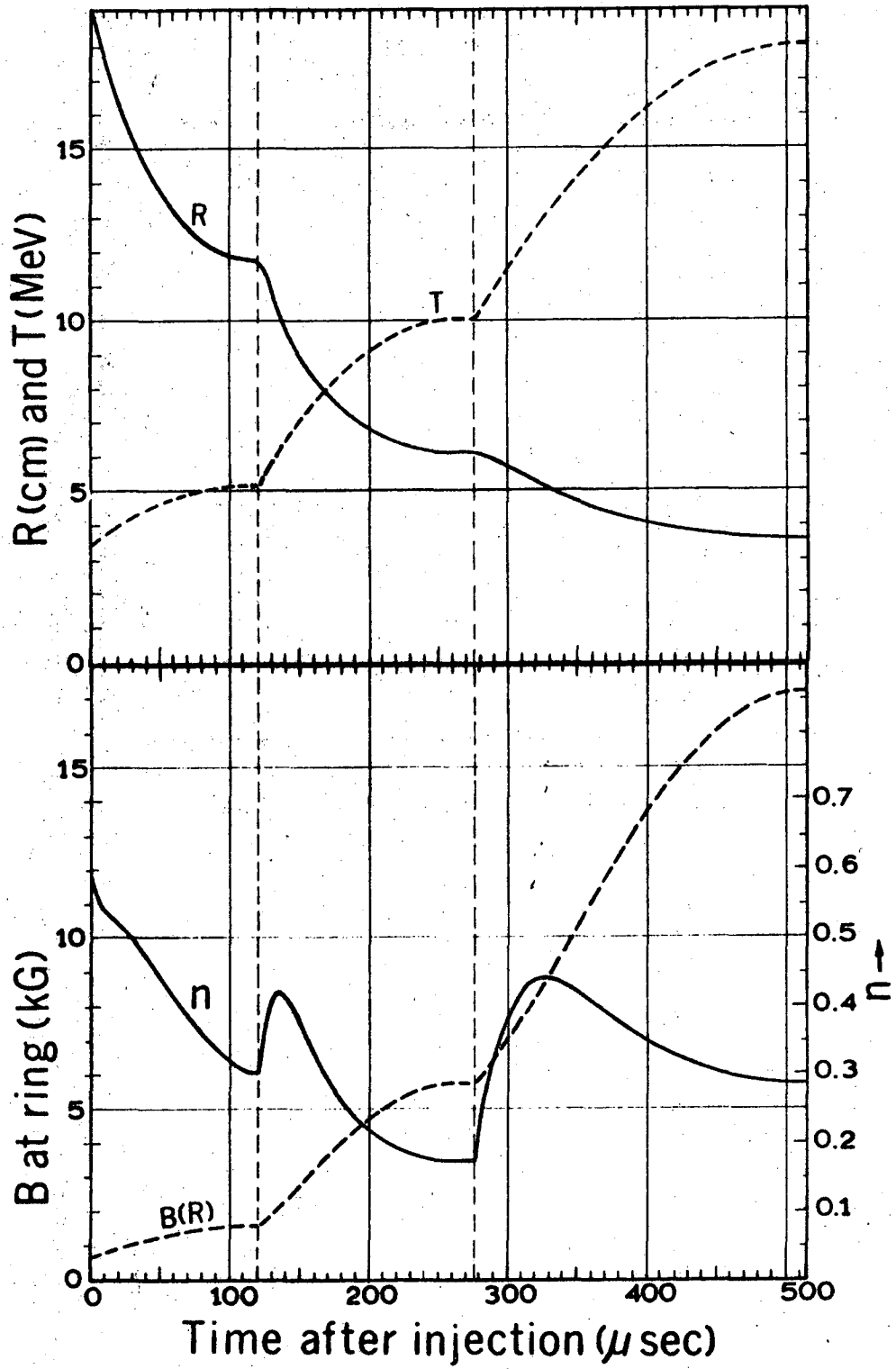

XBL 6812-6462

Figure 2

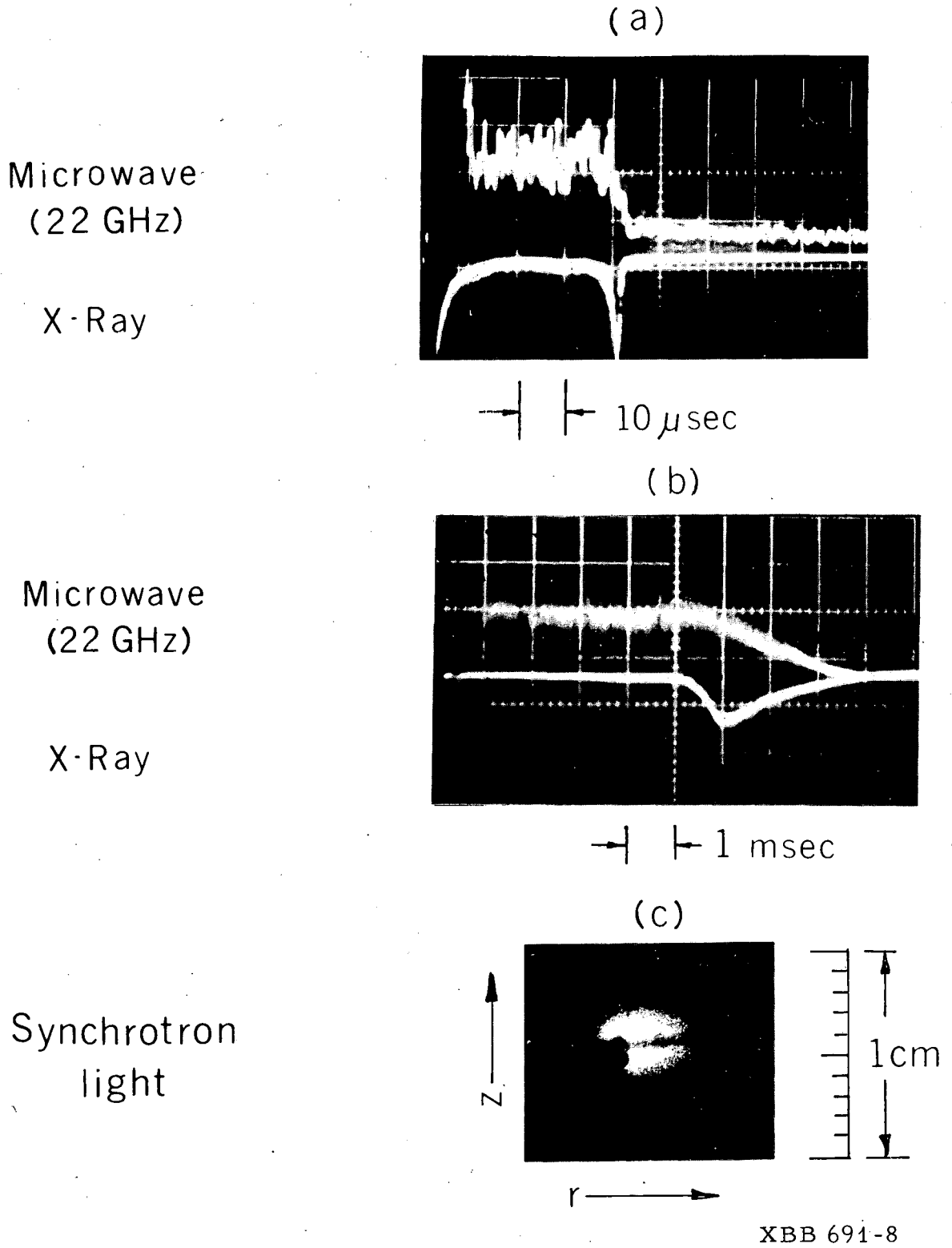

Figure 3

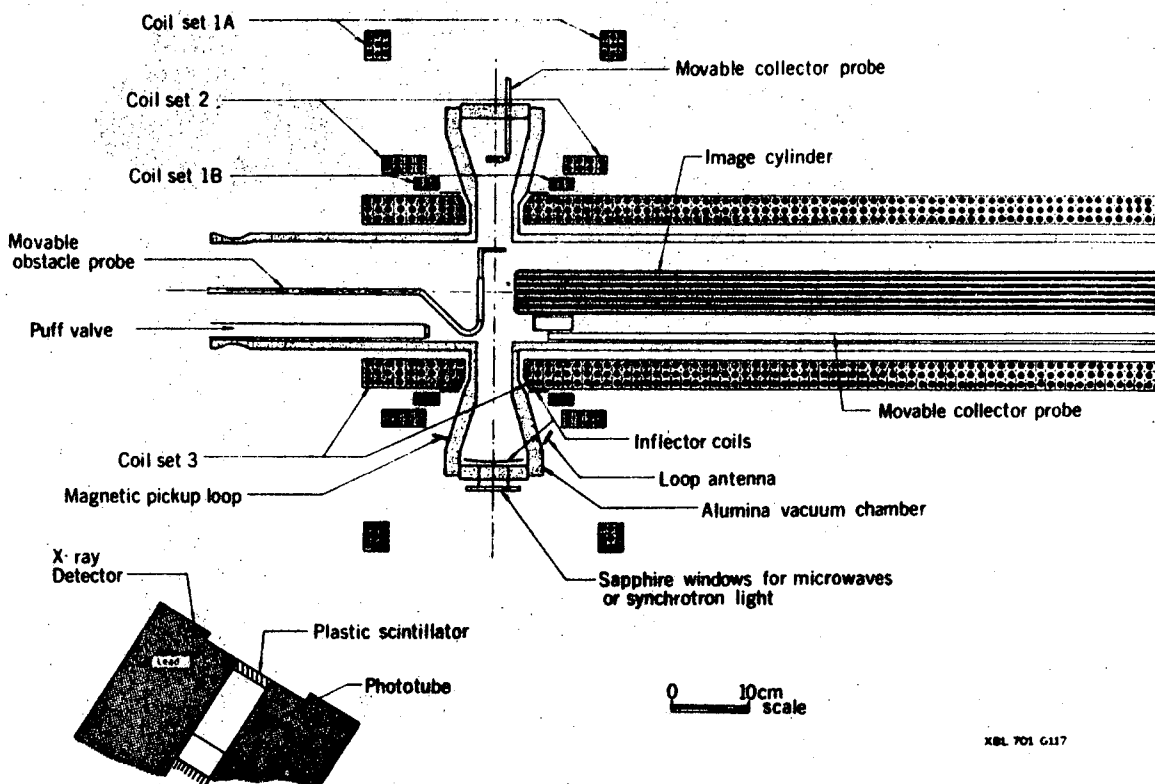
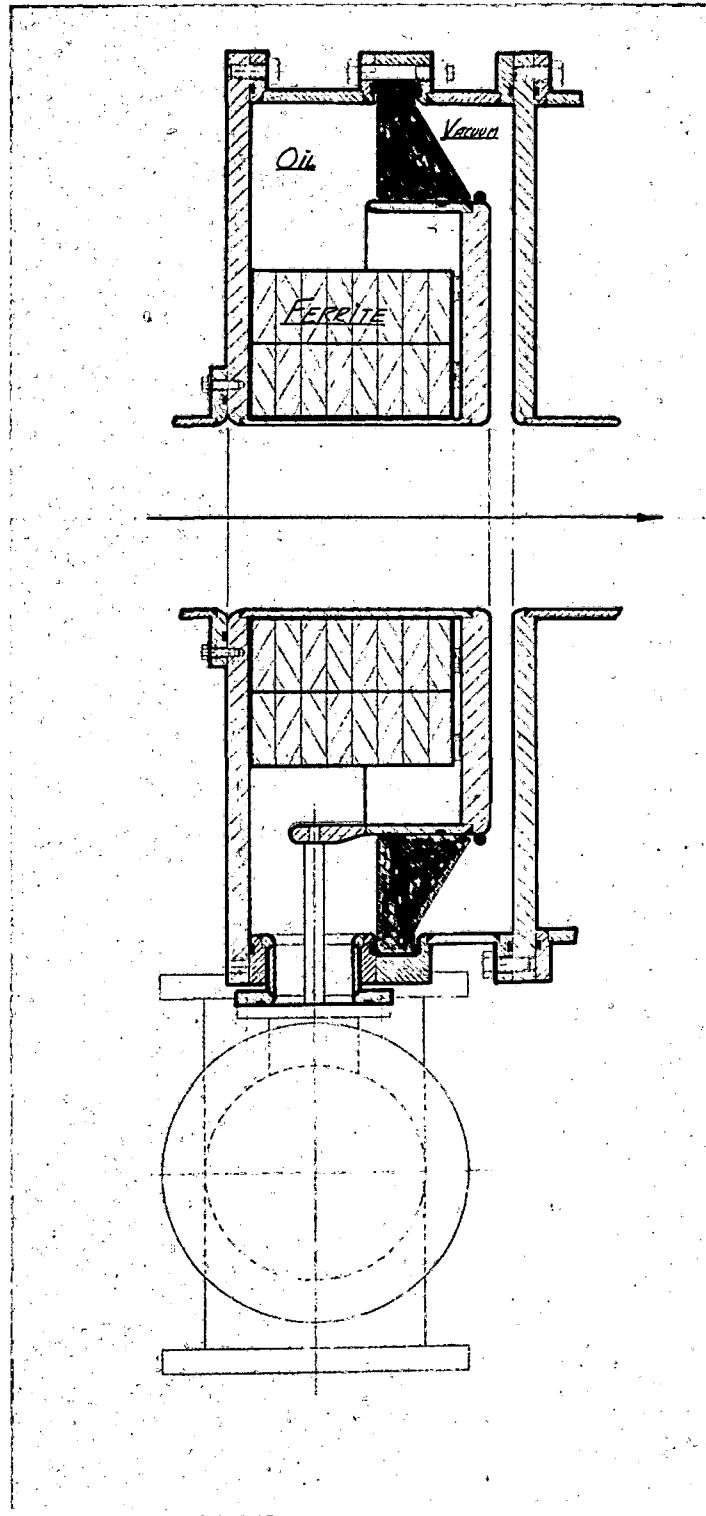
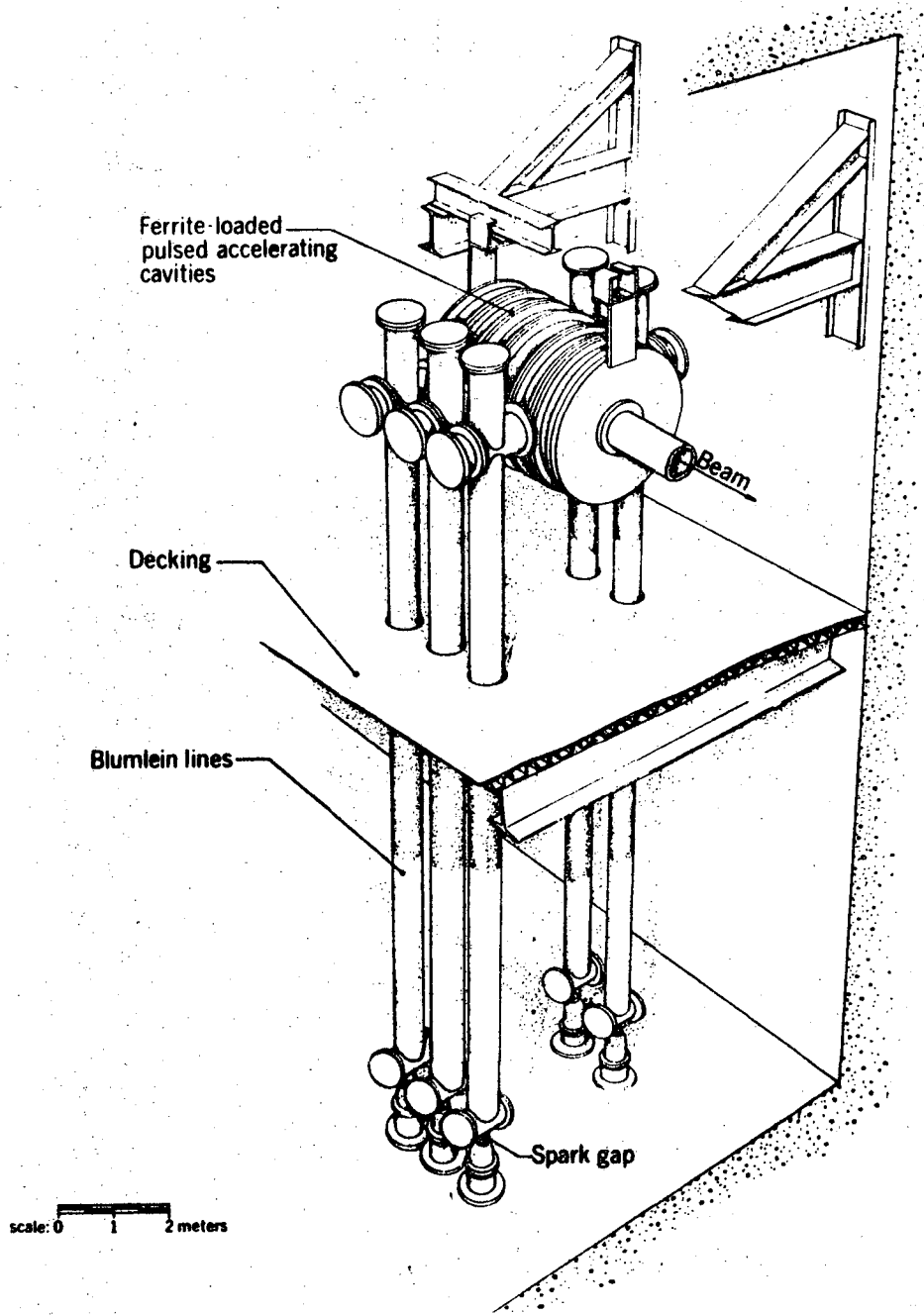

Figure 4



CBB 701-318

Figure 5



1.25 MeV Electron Induction-gun

XBL 698 4872

Figure 6

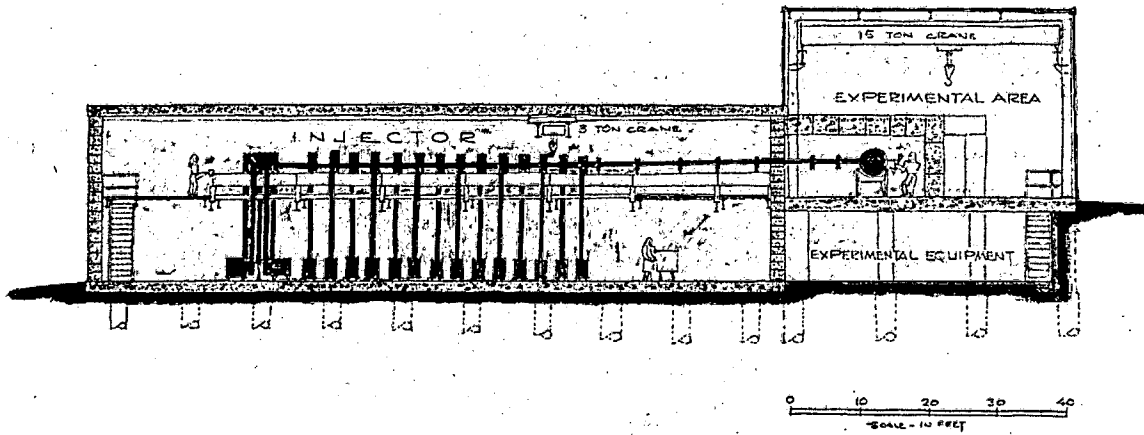

ACCELERATOR DEVELOPMENT FACILITY  
SECTION THRU INJECTOR TUNNEL AND EXPERIMENTAL AREA

XBC 701-409

Figure 7

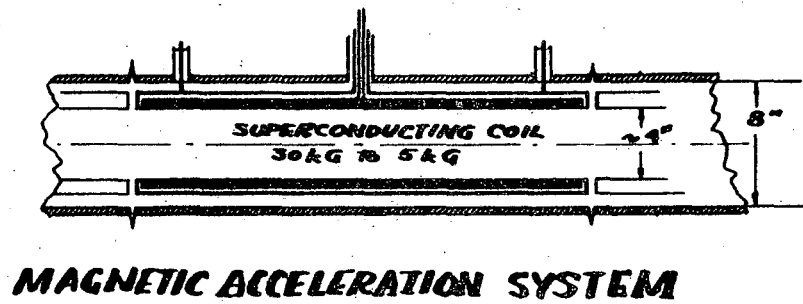
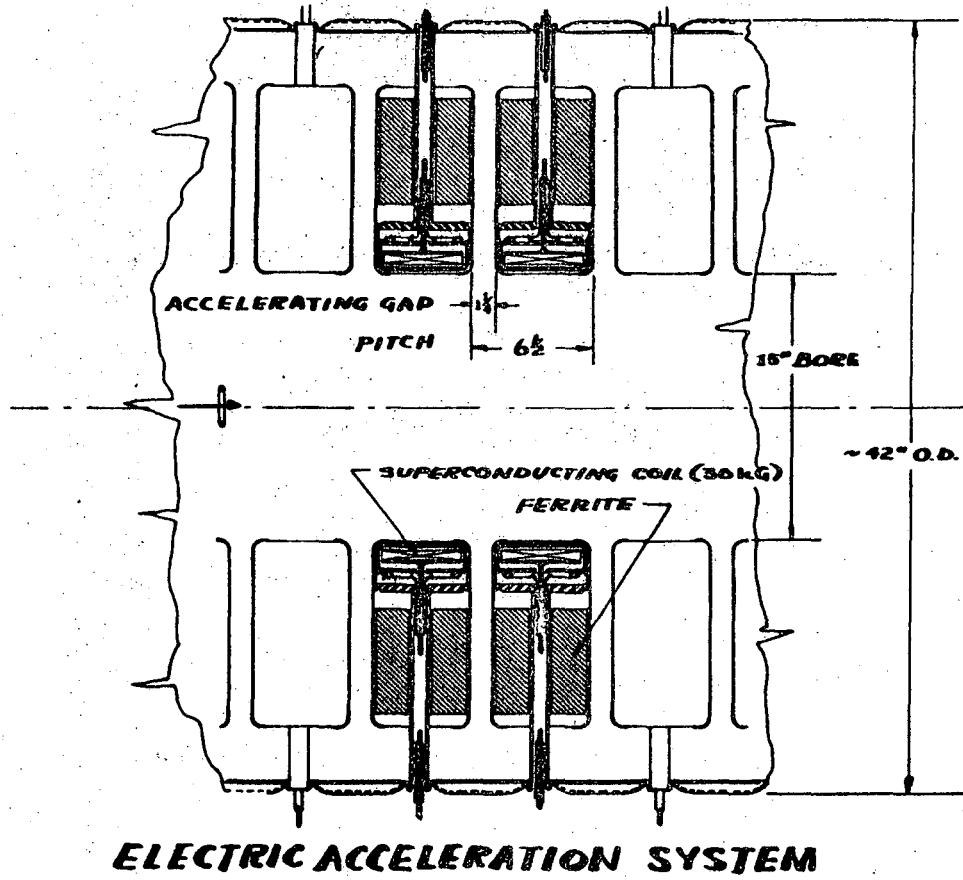

XBL 703 6164

Figure 8



LEGAL NOTICE

*This report was prepared as an account of Government sponsored work. Neither the United States, nor the Commission, nor any person acting on behalf of the Commission:*

- A. Makes any warranty or representation, expressed or implied, with respect to the accuracy, completeness, or usefulness of the information contained in this report, or that the use of any information, apparatus, method, or process disclosed in this report may not infringe privately owned rights; or*
- B. Assumes any liabilities with respect to the use of, or for damages resulting from the use of any information, apparatus, method, or process disclosed in this report.*

*As used in the above, "person acting on behalf of the Commission" includes any employee or contractor of the Commission, or employee of such contractor, to the extent that such employee or contractor of the Commission, or employee of such contractor prepares, disseminates, or provides access to, any information pursuant to his employment or contract with the Commission, or his employment with such contractor.*

TECHNICAL INFORMATION DIVISION  
LAWRENCE RADIATION LABORATORY  
UNIVERSITY OF CALIFORNIA  
BERKELEY, CALIFORNIA 94720

CP-07  
17A