

Lawrence Berkeley National Laboratory

Recent Work

Title

The ALS Gun Electronics System

Permalink

<https://escholarship.org/uc/item/5t21c4cb>

Author

Lo, C.C.

Publication Date

1993-05-12



Lawrence Berkeley Laboratory

UNIVERSITY OF CALIFORNIA

Accelerator & Fusion Research Division

Presented at the IEEE Particle Accelerator Conference,
Washington, D.C., May 17-20, 1993, and to be published
in the Proceedings

The ALS Gun Electronics System

C.C. Lo

May 1993

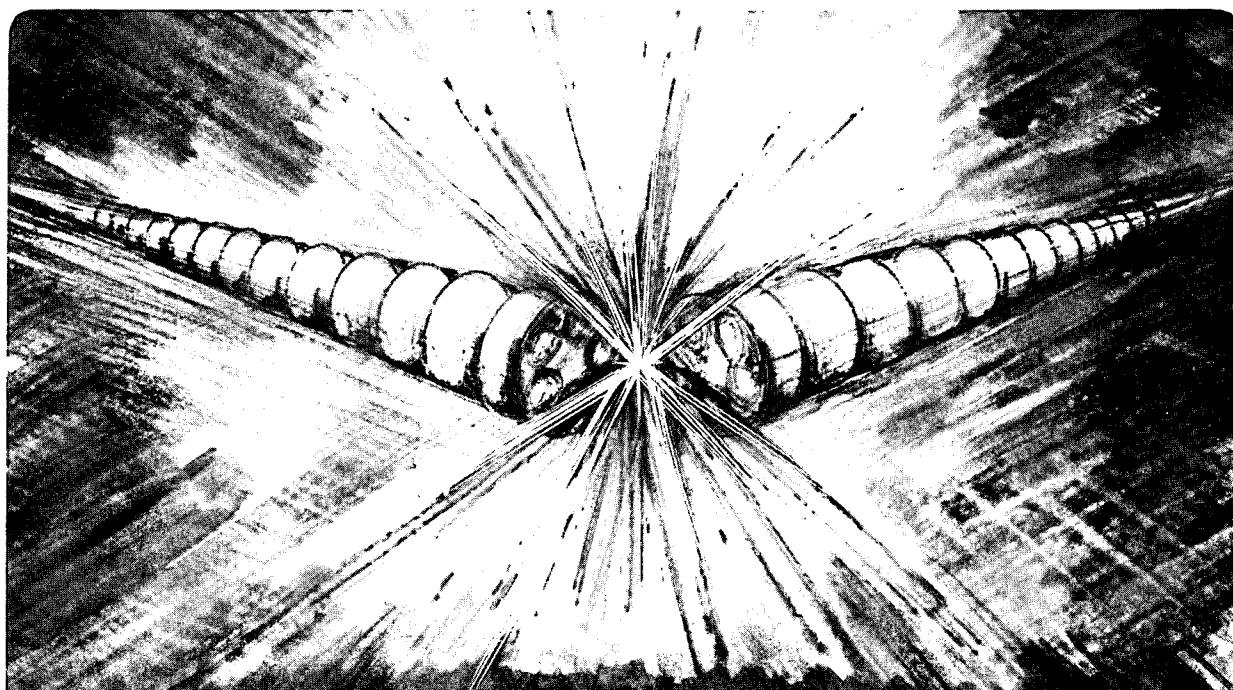

REFERENCE COPY |
Does Not |
Circulate |

Bldg. 50 Library.

LBL-33189

Copy 1

DISCLAIMER

This document was prepared as an account of work sponsored by the United States Government. While this document is believed to contain correct information, neither the United States Government nor any agency thereof, nor the Regents of the University of California, nor any of their employees, makes any warranty, express or implied, or assumes any legal responsibility for the accuracy, completeness, or usefulness of any information, apparatus, product, or process disclosed, or represents that its use would not infringe privately owned rights. Reference herein to any specific commercial product, process, or service by its trade name, trademark, manufacturer, or otherwise, does not necessarily constitute or imply its endorsement, recommendation, or favoring by the United States Government or any agency thereof, or the Regents of the University of California. The views and opinions of authors expressed herein do not necessarily state or reflect those of the United States Government or any agency thereof or the Regents of the University of California.

LBL-33189
UC-410
LSGN-104

THE ALS GUN ELECTRONICS SYSTEM

C.C. LO

ACCELERATOR and FUSION RESEARCH DIVISION
Lawrence Berkeley Laboratory
University of California
Berkeley, CA 94720

MAY 1993

This work was supported by the Director, Office of Energy Research, Office of Basic Energy Sciences, Materials Sciences Division, of the U.S. Department of Energy under Contract No. DE-AC03-76SF00098.

The ALS Gun Electronics System*

C.C. Lo
Lawrence Berkeley Laboratory, University of California
1 Cyclotron Road, Berkeley, CA 94720 USA

Abstract

The ALS Gun Electronics system has been designed to accommodate the gun with a custom made socket and a high speed electronics circuit which is capable of producing single and multiple electron bunches with time jitters measured at better than 50 PS. The system generates the gated RF signal at ground level before sending it up to the 120 KV-biased gun deck via a fiber optic cable. The current pulse width as a function of grid bias, using an Eimac 8847A planar triode simulating an electron gun, was measured to show the relationship between the two parameters.

I. INTRODUCTION

The ALS Electron gun[1] is a grid cathode assembly, HEY-171 made by Varian, Eimac Division. The cathode is the dispenser type with 1 square cm area capable of producing 1.5 amp peak current. The gun socket was designed and assembled with commercially available components with a grounded grid configuration. The grounding of the grid is implemented using eight chip capacitors arranged in a circular configuration. The cathode is driven by a gated burst of 125 MHz sinusoidal voltage whose amplitude is adjustable to control the cathode current pulse amplitude. Best efforts were made to match the gun socket to a 50 ohm transmission line which carries the 125 MHz drive signal from the power amplifier to the gun cathode.

A small portion of this signal is sent back out through a coaxial cable for monitoring purpose.

Since low time jitter performance is required, all electronic circuits in the system utilize Emitter Coupled Logic (ECL) devices. The start and stop timing pulses from the ALS Timing System[2] are also ECL signals. The 125 MHz RF is derived from the 500 MHz master clock, and it is the same signal used by the timing system.

II. SYSTEM OPERATION

Figure 1 shows a block diagram of the gun electronics system. The transmitter receives its 125 MHz signal from a divider whose 500 MHz input signal comes from the master oscillator. The 125 MHz signal is amplified, shaped and translated into a ECL level signal. Part of this is used to trigger a one shot which generates a logic level which indicates that RF is present. This signal is used to enable a D Flip Flop which serves as an edge detector for the start and stop pulses. The pulses generated by this stage have a width of 300 ns which is longer than the longest gate required. Without RF signal this stage is disabled and no output pulses can be generated.

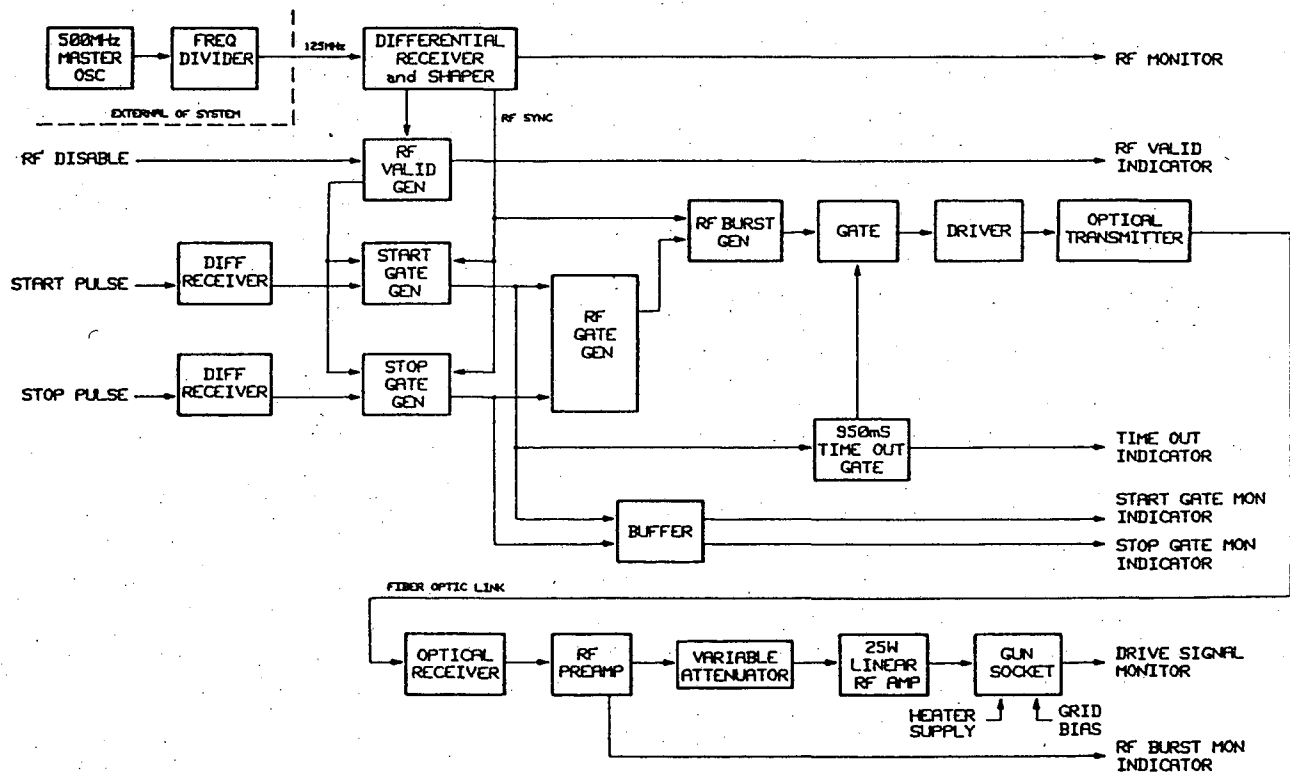

Figure 1. Block diagram of the ALS gun electronics system.

XBL-934-533

*This work was supported by the Director, Office of Energy Research, Office of the Basic Energy Sciences, Materials Sciences Division of the U.S. Department of Energy, under Contract No. DE-AC03-76SF00098.

The edge synchronized start and stop pulses are used to generate a gate whose width is determined by the time between the leading edges of the start and stop pulses from the ALS Timing System. A coincident circuit which follows generates a burst of 125 MHz RF signal with this gate. In the mean time the trailing edge of the 300 ns start pulse starts a 950 ms time out gate which is used to disable the RF gate generator for that duration of time. When this gate is activated via a jumper on the circuit board, there is a 950 ms dead time after one burst of gun pulses. This is used to safeguard the gun from being accidentally pulsed more than once per second from external sources.

The output from the RF gate is amplified and used to drive an optical transmitter which operates at the wavelength of 820nm. A fiber optic cable transmits the optical signal to a RF optical receiver on the high voltage deck. The output from the optical receiver is amplified and filtered before it is used to drive a 25 watts wide band RF amplifier whose output in turn drives the gun cathode. The grid bias control for the gun is also optically coupled to the high voltage deck and the bias level can be set and read back via fiber optical cable.

An external RF shut down control has been implemented to accommodate various operating requirements. The system will accept an external differential TTL logic level signal and shut down the RF gate generator. No signal will be generated to drive the cathode under this condition.

III. CURRENT PULSE WIDTH

An Eimac tube, 8847A[4], was used to simulate an electron gun for the current pulse width measurement. A toroidal transformer was used to monitor the current pulse width and amplitude when various bias levels were applied to the grid under certain drive conditions. Using a 50V peak, 125 MHz sinusoidal drive signal, the measured transfer functions of the current pulse width and amplitude versus the grid bias is given in Figure 2. The anode voltage was set at +400V for this measurement, at which point V_g (see below) was -5V. Although this measurement cannot represent the actual ALS gun performance, it does show the bias can be used to lower the current pulse width with a reduction in pulse current amplitude. The deviation of the measured pulse widths at high bias voltages could be partly due to measurement instrumentation bandwidth limitation.

The current pulse width generated by a sinusoidal drive signal with a triode whose grid is biased beyond cutoff can be represented by the following expression:

$$T_w = \frac{90 - \sin^{-1}((V_b - V_g + V_p) / 2V_p)}{180 f}$$

- where
- T_w = Output current pulse width at FWHM
 - $-V_b$ = Grid bias
 - $-V_g$ = Bias voltage at which the triode starts to conduct at the operating electric field gradient
 - $-V_p$ = Drive signal peak voltage
 - f = Frequency of drive signal in Hertz

Figure 2 also shows the limitation of this mode of operation. Other limiting parameters in the supporting system

also enter the picture when higher current pulse amplitude and narrower current pulse width are required. Different schemes of generating a higher amplitude and narrower current pulse width may be necessary if such requirement should exceed the capability of the present system. Figure 3 shows a typical pulse train produced by the ALS electron gun as monitored by a Wall Current Monitor[3].

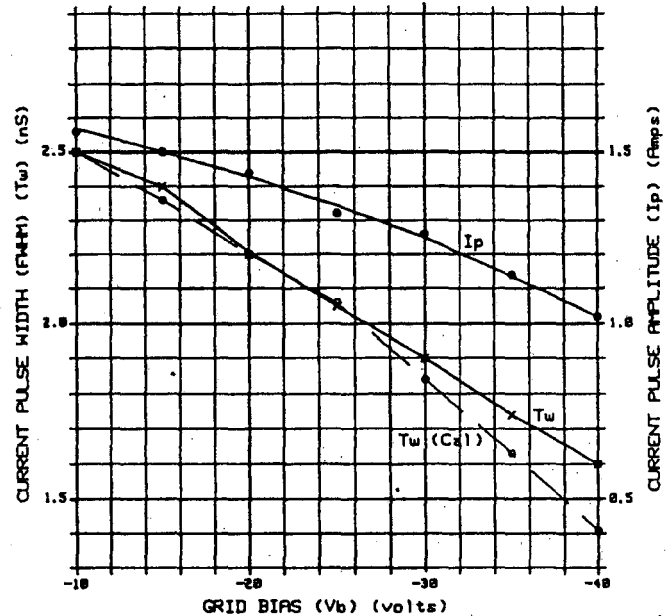

Figure 2. Current pulse width and amplitude vs grid bias.

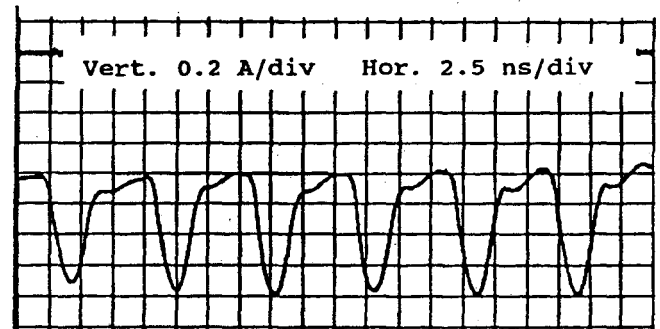

Figure 3. ALS gun pulses as monitored by the Wall Current Monitor.

IV. CONCLUSION

The Gun Electronics System was developed to provide the ALS with single or multiple electron bunches with low time jitter performance. ECL devices are used in all timing and logic circuits to ensure low time jitter for the electron bunches. The time jitter has been measured at better than 50 ps FWHM with available instruments on hand. The processing of most signals on the ground end helps reduce the power requirement at the high voltage deck, and also reduces the optical component count of the system. The system has been operating for many months without any problem. Further work on

pulse amplitude may be needed if such parameters are desired in future operations.

V. ACKNOWLEDGMENT

This work was funded by the director, Office of Energy Research, Office of Basic Energy Sciences, Material Science Division of the U.S. Department of Energy under Contract No. DE-AC03-76SF00098 with Lawrence Berkeley Laboratory. Reference to a company or a product name does not imply approval or recommendation of the product by the University of California or the U.S. Department of Energy to the exclusion of others that may be suitable.

VI. REFERENCES

- [1] Hermosa Electronics, Instruction Book For LBL Electron Gun.
- [2] M. Fahmie, Design of the Advanced Light Source Timing System. To be presented in this Conference.
- [3] J. Hinkson, Performance of Advanced Light Source Particle Beam Diagnostics. To be presented in this Conference.
- [4] Brian Taylor, Private communication.

LAWRENCE BERKELEY LABORATORY
UNIVERSITY OF CALIFORNIA
TECHNICAL INFORMATION DEPARTMENT
BERKELEY, CALIFORNIA 94720