

# Lawrence Berkeley National Laboratory

## Lawrence Berkeley National Laboratory

### **Title**

CERTS: Consortium for Electric Reliability Technology Solutions -  
Research Highlights

### **Permalink**

<https://escholarship.org/uc/item/5x17s9sk>

### **Author**

Eto, Joseph

### **Publication Date**

2003-07-30

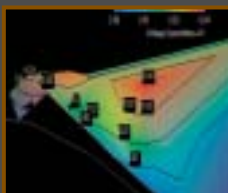

# CERTS

CONSORTIUM FOR ELECTRIC RELIABILITY TECHNOLOGY SOLUTIONS



RESEARCH

HIGHLIGHTS

2003



**THE U.S. ELECTRICITY GRID TODAY** The U.S. electric power system is in the midst of a fundamental transition from a centrally planned and utility-controlled structure to one that will depend on competitive market forces for investment, operations, and reliability management. Electricity system operators are being challenged to maintain the reliability of the grid and support economic transfers of power as the industry's structure changes and market rules evolve. Meanwhile, the U.S. economy depends more than ever on reliable and high-quality electricity supplies. New technologies are needed to prevent major outages such as those experienced on the Western grid on August 10, 1996, which left 12 million people without electricity for up to eight hours and cost an estimated \$2 billion.

The Consortium for Electric Reliability Technology Solutions (CERTS) was formed in 1999 to research, develop, and disseminate new methods, tools, and technologies to protect and enhance the reliability of the U.S. electric power system and functioning of a competitive electricity market. CERTS is currently conducting research for the U.S. Department of Energy (DOE) Transmission Reliability Program and for the California Energy Commission (CEC) Public Interest Energy Research (PIER) Program. The members of CERTS include the Electric Power Group, Lawrence Berkeley National Laboratory, Oak Ridge National Laboratory, Pacific Northwest National Laboratory, the National Science Foundation's Power Systems Engineering Research Center, and Sandia National Laboratories.

## **CERTS' ROLE:**

Historically, the U.S. electric power industry was vertically integrated, and utilities were responsible for system planning, operations, and reliability management. As the nation moves to a competitive market structure, these functions have been disaggregated, and no single entity is responsible for reliability management. As a result, new tools, technologies, systems, and management processes are needed to manage the reliability of the electricity grid.

However, a number of simultaneous trends prevent electricity market participants from pursuing development of these reliability tools: utilities are preoccupied with restructuring their businesses, research funding has declined, and the formation of Independent System Operators (ISOs) and Regional Transmission Organizations (RTOs) to operate the grid means that control of transmission assets is separate from ownership of these assets; at the same time, business uncertainty, and changing regulatory policies have created a climate in which needed investment for transmission infrastructure and tools for reliability management has dried up. To address the resulting emerging gaps in reliability R&D, CERTS has undertaken much-needed public interest research on reliability technologies for the electricity grid.

## **CERTS' VISION:**

- Transform the electricity grid into an intelligent network that can sense and respond automatically to changing flows of power and emerging problems;
- Enhance reliability management through market mechanisms, including transparency of real-time information on the status of the grid;
- Empower customers to manage their energy use and reliability needs in response to real-time market price signals; and
- Seamlessly integrate distributed technologies—including those for generation, storage, controls, and communications—to support the reliability needs of both the grid and individual customers.

CERTS is developing technology solutions that support competitive markets while protecting the public interest in reliable electricity service. CERTS' electricity reliability research covers five areas:

**Real-Time Grid Reliability Management**—developing tools and technologies that help monitor and operate the power system reliably in a competitive electricity market and laying the groundwork for the transition to a smart, switchable network that can anticipate and respond automatically to emerging problems. Current work focuses on prototyping and demonstrating real-time reliability management tools, developing system security management tools, and conducting applied research on advanced measurement technologies and controls.

**Reliability and Markets**—performing science-based analysis and demonstrations of options for increasing the effectiveness of market-based approaches for managing reliability. Current work focuses on evaluating market designs for reliability management using theoretical and experimental economics approaches, assessing the market's impact on the reliability of grid operations, and developing monitoring tools to detect market problems as they emerge.

**Distributed Energy Resources Integration**—developing tools and techniques to maintain and enhance the reliability of electricity service through a cost-effective, decentralized electricity system based on high penetrations of distributed energy resources (DER) (small, autonomous energy-generation, storage, and load control resources typically located at customers' premises). Current work focuses on developing tools and data and conducting field tests of an advanced system integration, protection, and control concept called the CERTS Microgrid. The CERTS Microgrid concept is a new approach to integrating large numbers of small (less than one-megawatt) DER into clusters that present themselves as controllable loads to the surrounding electricity system and thus do not require central dispatch by a system operator.

**Load as a Resource**—performing analysis and demonstrations to enable meaningful participation of load in competitive electricity markets, including experimental economics analysis of the effect of price-responsive load in reducing market prices and price volatility, assessments of emerging demand-response programs and technologies for enabling customer participation in electricity markets, and demonstrations of the use of load to provide ancillary services (notably spinning reserve).

**Reliability Technology Issues and Needs Assessment**—monitoring and identifying technology trends and emerging gaps in electricity system reliability research and development (R&D) to anticipate what R&D efforts are in the public interest to enable the grid of the future.

# Real-Time Grid Reliability Management

CERTS Real-Time Grid Reliability Management research focuses on developing and prototyping software tools that will ultimately enable the electricity grid to function as a smart, automatic, switchable network. These tools are envisioned to:

- Improve understanding of the impacts of competitive market forces on management of system reliability;
- Provide real-time data and support information that will enable operators to quickly grasp and analyze system status and respond effectively;
- Allow operators to measure, monitor, assess, and predict the performance of the system and the behavior of market participants;
- Allow rapid incorporation of the latest sensing, data communication, visualization, and algorithmic technologies.

CERTS' work in this area is based on the recognition that past, off-line, engineering-based modeling and analysis of system performance are no longer adequate because markets—rather than centralized engineering decision making—now determine how the transmission system is used.

As a result, tools are needed to identify, in real time, critical resource deficiencies that could endanger system reliability, as well as to reliably and efficiently match customer demands with supplies of electricity. CERTS is identifying, prototyping, demonstrating, and disseminating software that will:

- Measure key system operating and market parameters (frequency, voltage, congestion, market power);
- Monitor and graphically represent system performance—i.e., how far the system is from the “edge”;
- Track, identify, and save data on abnormal operating patterns; and
- Predict system response in near-real time, by means of simulations and “what-if” analysis.

Using this software, operators will be able to rapidly and intuitively assess system health and vulnerabilities in real time and undertake corrective actions.

## KEY ACCOMPLISHMENTS:

- CERTS Area Control Error (ACE)-Frequency Real-Time Monitoring System
- CERTS Control Area and Supplier's Performance for Automatic Generation Control and Frequency Response Services System
- CERTS VAR-Voltage Management Tool
- CERTS Monitoring Applications based on Synchronized Phasor Measurements

## PROJECT HIGHLIGHT: CERTS VAR-Voltage Management Tool

The CERTS VAR-Voltage Management Tool substitutes a visual, bird's-eye view of the overall health of the grid for difficult-to-read tables of voltages at each monitoring point within the electricity system. By mining, analyzing, and presenting operational data in an easy-to-understand visual format, this tool addresses a key problem facing operators today—data overload—and enables them to effectively and reliably maintain safe operating margins.

This tool gives reliability coordinators and system operators immediate access to information on system voltages over a wide area, and, more importantly, reactive reserve margins at critical grid locations. The tool provides sensitivity calculations, distances from voltage collapse, remedial action options, and geographically oriented visual displays. Had it been available at the time, the VAR-Voltage Management Tool would have been instrumental in alerting operators to dangerously low reactive reserve margins in the summer of 1996 and might have prevented the resulting widespread power outages that crippled the West Coast.

The tool has been installed at both the Folsom and Alhambra California Independent System Operator (CAISO) control centers.

“Since the market began, no central dispatcher determines how generation will be dispatched, therefore anticipating and planning for all possible contingencies has become much more difficult for system operators. Real-time operating tools, like the CERTS VAR-Voltage Management Tool, are needed to quickly detect early warning signals and then maneuver the system to safer operating regions, long before significant reliability threats can arise.”

Terry Winter,  
CEO of CAISO

*Voltages (and voltage reserves) across the entire western interconnection are presented visually using different colors to indicate high (green), normal (blue), and low (red) voltage conditions. Diagnostic analysis of observed conditions to determine their severity and effectiveness of different options to address them are integrated directly into the displays.*

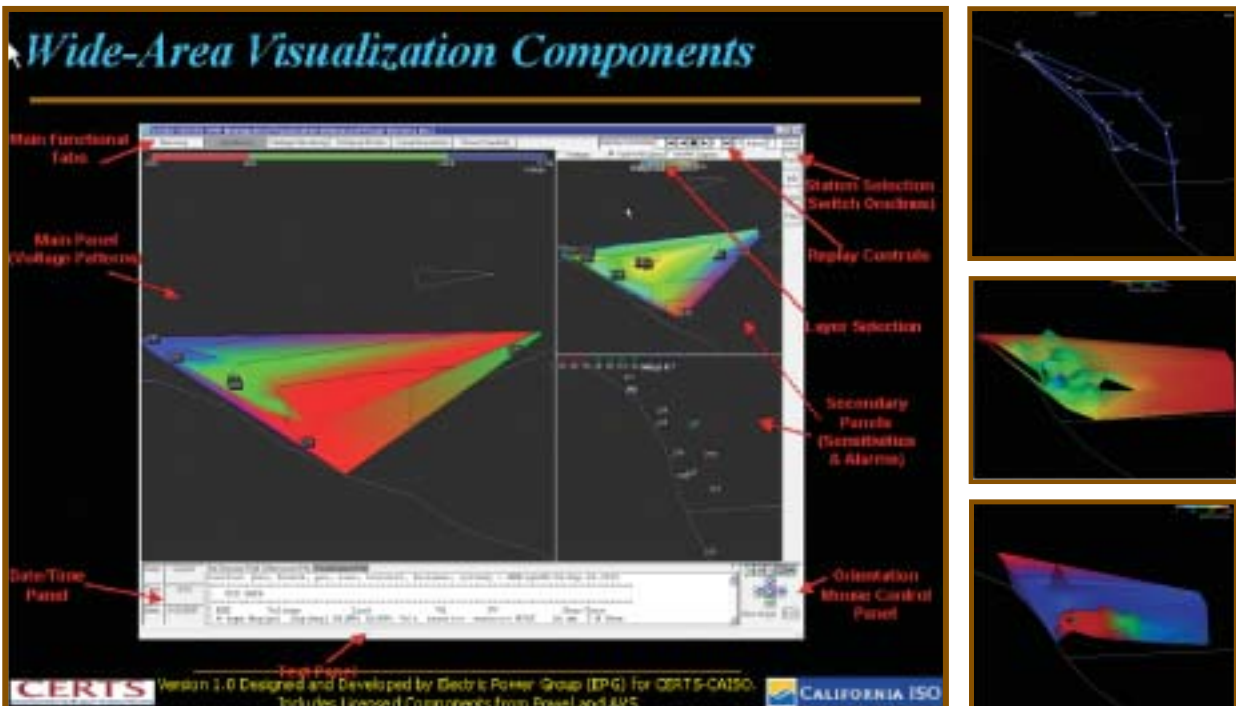



## PROJECT HIGHLIGHT: CERTS ACE-Frequency Real-Time Monitoring System

Reliability Coordinators throughout the nation are now using a new real-time monitoring tool developed by CERTS for the North American Electric Reliability Council (NERC)<sup>1</sup>. The CERTS Area Control Error (ACE) Frequency Real-Time Monitoring System allows Reliability Coordinators to monitor compliance with NERC rules designed to ensure the reliable supply of electricity. Until this tool was introduced, months of data analysis were required to determine the causes of rule violations that threatened reliability, so corrective action was not possible until it was too late. Now, however, the ACE Frequency Real-Time Monitoring System immediately alerts Reliability Coordinators to conditions that threaten reliability so that there is time to work with out-of-compliance control areas to correct impending problems in real time, reducing the chances of unplanned blackouts.

The ACE tool uses data visualization techniques to assess compliance with NERC reliability rules for the 143 control areas in North America. The tool relies on data generated every four seconds by all control areas and creates a real-time visual display of the entire power grid. This display immediately alerts NERC Reliability Coordinators to emerging frequency abnormalities within an interconnection and can pinpoint the control areas causing the violations. Armed with this information, coordinators can initiate corrective actions within minutes to prevent further degradation of system reliability.

CERTS released the tool to all 23 NERC Reliability Coordinators and selected control areas in the fall of 2002. Four special training sessions were conducted in each region of the country in November and December 2002, hosted by the Midwest ISO, the New York ISO (NYISO), Southern Company, and CAISO.

<sup>1</sup>Under the auspices of NERC, Reliability Coordinators monitor and coordinate reliability management among multiple control areas. There are 23 Reliability Coordinators throughout the Western and Eastern Interconnections. CAISO is one of the three Reliability Coordinators in the Western Interconnection.

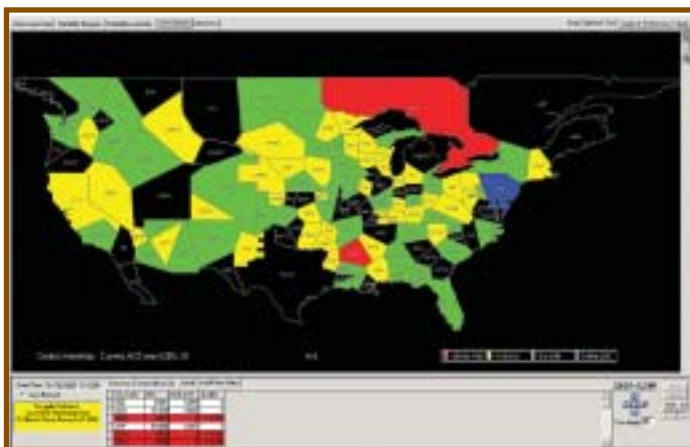

“The CERTS ACE tool provides us with a means to measure system performance against NERC reliability standards.”

Michehl Gent,  
CEO of the North  
American Electric  
Reliability Council

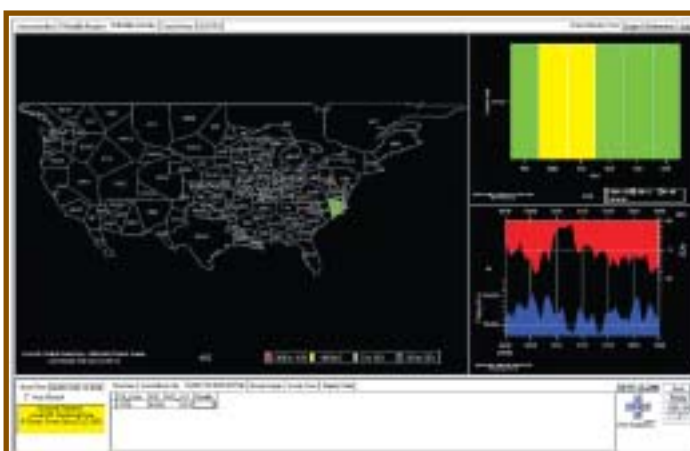

Visual displays allow NERC Reliability Coordinators to pin-point interconnections, reliability regions, or control areas that are over-generating (green) or under-generating (red) in real time. Tracking displays record and present the information over time to enable corrective actions for persistent excursions from agreed upon limits.

## PROJECT HIGHLIGHT: CERTS Synchronized Phasor Measurement Tools

CERTS is researching the deployment of next-generation, real-time grid monitoring system and control applications. One major development in this area is phasor measurement technology. Current grid-monitoring technologies take snapshots of the state of the system every four seconds. However, transient phenomena that threaten reliability can occur during much briefer time intervals because the North American AC system operates at 60 cycles per second. Phasor technologies take measurements many times per second, recording the exact shape of the 60-cycle wave form. Use of phasor measurement technology over wide areas is critical to supporting reliable regional and inter-regional electricity transfers.

CERTS has integrated and delivered three software applications based on phasor measurements. Operation support engineers at the California ISO (CAISO) are using these applications to study grid disturbances and calibrate system models that are used to develop guidelines for real-time operations, in coordination with the Western Electricity Coordinating Council.

In addition, phasor data collected by the Bonneville Power Administration, Southern California Edison, and Pacific Gas and Electric Company are being transferred to a CAISO data concentrator for use in prototype real-time monitoring workstations that are being built by CERTS for CAISO dispatchers. Data sharing of this type is essential to support the wide-area reliability management needs of the western U.S.

By utilizing the new monitoring workstations developed by CERTS, CAISO is pioneering the first-ever, real-time application of phasor technology. The new workstations provide phasor data in real time so that grid operators can form a more accurate picture of the actual health of the grid than has been possible with previous monitoring techniques. Use of real-time phasor data will allow operators to verify that their systems remain within safety margins.

There is growing recognition that phasor technology is needed to support reliable transfers of power across the Eastern Interconnection as well. DOE is currently working with eastern ISOs to demonstrate region-wide sharing of real-time information from phasor measurement technologies.



*Far left: Phasor measurements are time-stamped using the geosynchronous satellite positioning system so that measurements from across the interconnection can be precisely aligned for comparison against one another.*

*Near upper left: Prototype display of phasor measurements taken at critical locations across the interconnection.*

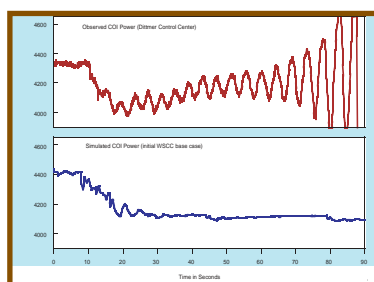

*Near bottom left: Comparison of predicted conditions prior to August 10, 1996 blackout (lower panel) and conditions actually recorded by phasor technologies (upper panel) showed that the planning models were not able to accurately capture underlying causes of the blackout.*

# Reliability and Markets

CERTS' objective in the area of Reliability and Markets is to conduct science-based research to understand how to design (as well as test and monitor) fair and transparent markets that will efficiently provide reliable electricity to consumers. As an impartial third party, CERTS can make technically sound investigations based on consistent economic principles, including investigations of market operations to understand current market events (e.g., price spikes) and analysis of the likely effects of proposed market design changes. Deepening the understanding of market operations will both decrease the need to interfere with the market (e.g., through price caps) and provide guidance to support operating decisions that improve reliability and market performance.

CERTS is developing a comprehensive set of integrated market/engineering design principles and tools for a restructured electricity industry. Development of these principles and tools relies on:

- Theoretical analysis, focusing on modeling and employing techniques of operations research, systems analysis, microeconomics, stochastic modeling, game theory, and auction theory.
- Empirical analysis, focusing on gathering and interpreting empirical data and on estimating and validating theoretical models, using econometric methods, financial engineering approaches, statistical analysis, and data mining.
- Computational methods, employing numerical approaches and agent-based models to simulate and forecast market outcomes and using realistic modeling of the electric power system in conjunction with behavioral models of economic agents that control various aspects of the system and interact in the marketplace.
- Experimental economics approaches, employing controlled laboratory experiments with live and artificial agents to explore decision patterns under alternative rules and system conditions and to test behavioral assumptions on which such rules are based.

## KEY ACCOMPLISHMENTS:

- Collaboration with NYISO on market design enhancements.
- Developed PowerWeb Experimental Economics Platform.
- Provided input to “Blue Ribbon” Panel on California Power Exchange.

“It is our responsibility as regulators to ensure that wholesale electricity market designs are thoroughly tested before they are implemented and that they are rigorously monitored to ensure they serve the public interest in electricity reliability and market efficiency.”

Marsha Smith,  
Idaho Public Utilities Commission,  
Chair of National Association of  
Regulatory Utility Commissioners,  
Electricity Committee

## PROJECT HIGHLIGHT: PowerWeb Experimental Economics Platform

The institutional structure that has resulted from deregulation of the U.S. electricity industry is highly decentralized. The result is that, in effect, a number of market experiments are now being conducted throughout the country. Unfortunately, the consequences of deficiencies in these new markets are expensive for many participants (e.g., California). By contrast, experimental economics is an inexpensive framework for testing the performance of deregulated markets in controlled settings without the severe economic costs to the public of real-world market failures.

Participants in experimental markets are paid real money in proportion to how well they do at making profits. This framework is extremely effective in getting participants to search for and exploit weaknesses in the market. These experiments make it relatively easy to identify why markets do not perform well, opening up the potential for designing (and testing) new market structures that will work better.

The experimental economics platform developed by CERTS to test markets, PowerWeb, is relatively small compared to a typical network for one of today's ISO markets. However, PowerWeb simulates a full alternating current (AC) network and is able to capture many of the complex issues unique to electric power. In particular, this tool makes it possible to design experiments that focus on one specific feature of a market to determine how that feature affects market performance.

CERTS has been using PowerWeb to test market designs during the past three years and is working closely with NYISO staff to conduct experiments that can provide insight on specific market design issues currently being addressed by NYISO. The focus of these efforts has been to test:

- The performance of day-ahead/balancing markets in terms of economic efficiency and reliability (i.e., the ability to respond to unexpected load fluctuations);
- Alternative market structures for ancillary services (reserves and voltage support);
- The effects of demand response on market performance; and
- Mechanisms for mitigating the price-spike behavior that has been seen in all functioning markets to date.

*At the end of each round of an experimental market auction, offers are arranged from lowest to highest. Market clearing price is set based on the last accepted offer (blue horizontal line). Each participant submits offers for multiple generators (all the same color). Offers can exceed actual operating costs for each unit (lighter shaded, lower portion of each offer).*

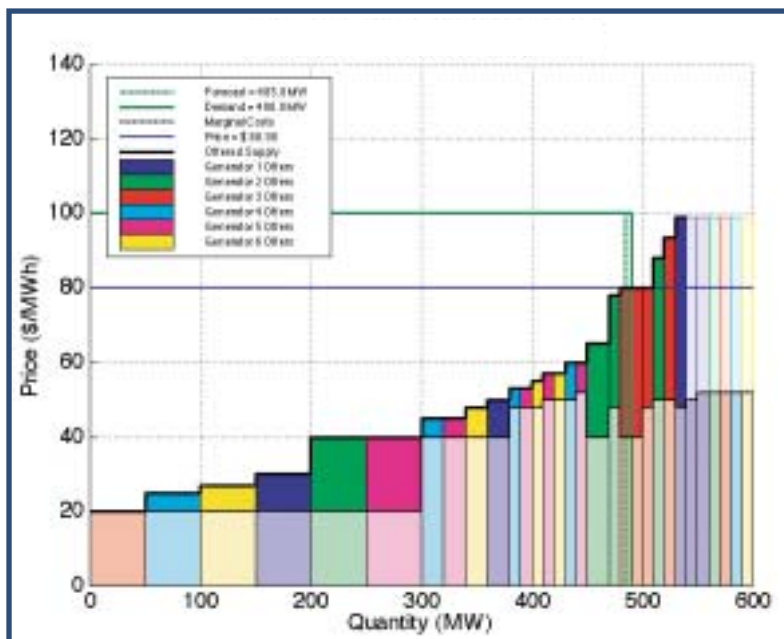

*Accepted offers must first be deemed feasible, given the configuration and physical capabilities of the underlying electricity network.*

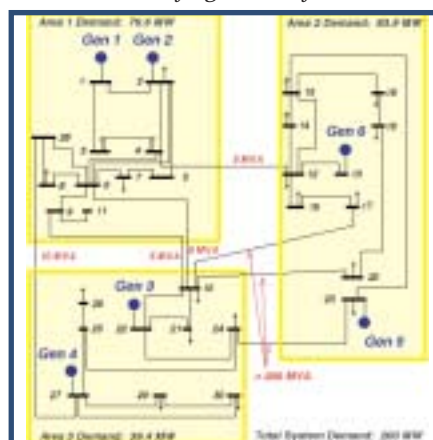

# Distributed Energy Resources (DER) Integration

DER are autonomous generating, storage, and load control technologies that are typically located at customer premises and operated for the customer's benefit. They include microturbines, fuel cells, photovoltaic systems, and traditional internal combustion engines. CERTS is evaluating how these resources, when deployed in large numbers, affect and could be modified to enhance electricity grid reliability.

Large-scale market adoption of DER raises important issues about DER's impact on the grid's reliability. Specific areas that must be addressed include: control and dispatch strategies for DER; strategies to ensure the safety and protection of the grid; and the role of power electronic interfaces in connecting DER to the grid. Assessing grid reliability impacts requires a systems approach.

A central concept in this research area is the microgrid, an interconnected network of DER that can function connected to or separate from the electricity grid. CERTS is investigating optimal microgrid designs, including the power electronics necessary to connect microgrids effectively to the power grid; conducting field tests of microgrid operation; and assessing the system reliability services that microgrids might provide.

## KEY ACCOMPLISHMENTS:

- Prepared white paper on CERTS Microgrid concept.
- Conducted industry workshop on microgrids for CEC PIER.
- Developed power-flow analysis tool tailored to support design of microgrids and help address distribution and in-plant electrical design and operation problems created by integration of DER.
- Developed customer-adoption model to optimize DER sizing and technology selection decisions and operational strategies, especially for DER involving combined heat and power applications.

“The DOE/CEC PIER collaboration is the best I have seen in leveraging Federal and State funds to transfer technology into the field to benefit both our interests. The Consortium for Electric Reliability Technology Solutions with its unique national and California representation continues to play a large part in this technology transfer, and I expect our collaboration to produce further successes.”

Philip Overholt,  
Program Manager  
for the U.S. DOE Transmission  
Reliability Program

## PROJECT HIGHLIGHT: The CERTS Microgrid

CERTS' DER research is organized around the microgrid concept. A microgrid involves large numbers of small DER (less than one-megawatt each) located on the low-voltage distribution system. At the heart of CERTS' microgrid concept is the notion of a flexible, controllable interface between the microgrid and the wider power system. This interface can isolate the microgrid's internal electrical operations from those of the surrounding distribution system while maintaining the economic connection between the two. The conditions and quality of service within the microgrid are determined by the needs of the customers involved; flows across the interface between the microgrid and the distribution system are determined by the needs of the wider power system.

The CERTS Microgrid concept recognizes that the nation's electricity grid cannot economically deliver the increased reliability and power quality now required for certain uses of electricity. DER solutions are needed that can meet the twin goals of delivering more reliable service to specific customers and enhancing the performance of the interconnected grid.

Microgrids could improve the reliability of power delivery and reduce the cost of maintaining the wider power system. CERTS is working under the premise that microgrids will become a reality in the next 20 years and is pursuing research to enable application of microgrids in an electrically, economically, and environmentally sound manner. Toward this end, CERTS is developing data on the dynamic performance of microsources (e.g., microturbines) in a laboratory at the University of California, Irvine; creating new modeling tools and collecting relevant data to study microgrids; and planning microgrid field demonstrations. In 2004, CERTS will demonstrate a full-scale microgrid utilizing three or more microsources.

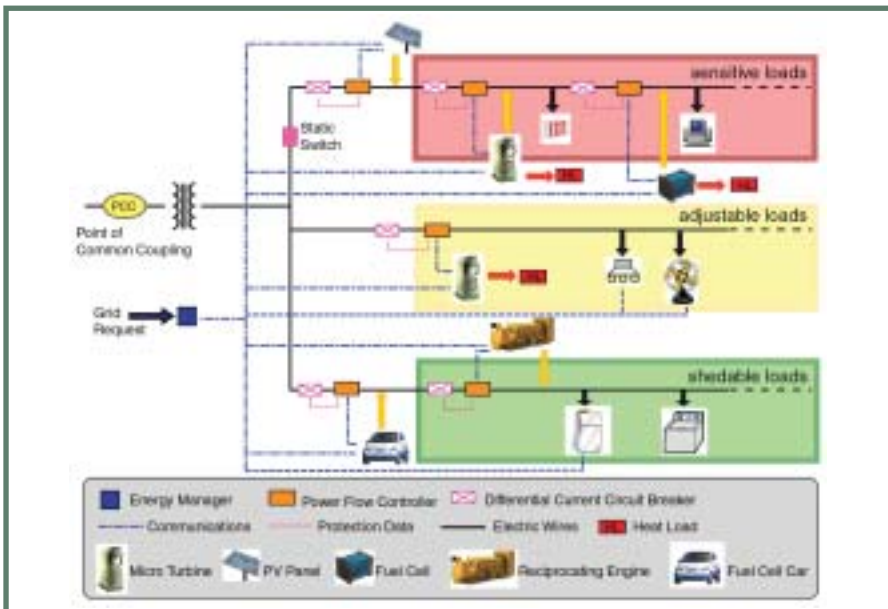

*A static switch instantly isolates a portion of the microgrid from the utility whenever there is a disturbance on the utility side in order to allow sensitive or critical loads within the microgrid to continue operating, supplied solely by distributed energy resources within the microgrid.*

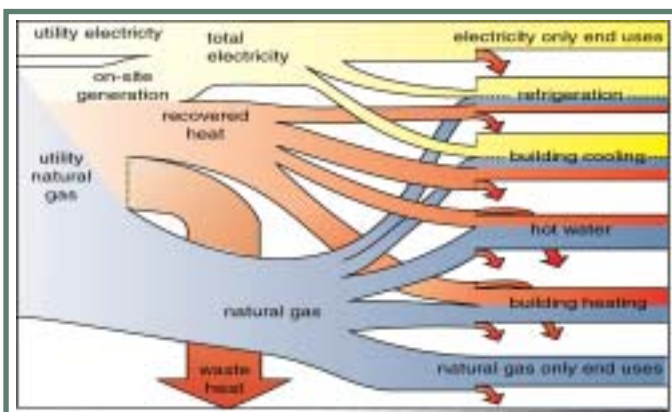

*Co-locating distributed energy resources with electrical and thermal loads within the microgrid is essential for realizing the full energy-efficiency potential of distributed energy resources through recovery and application of waste heat from electricity generation to building end-uses.*

# Load as a Reliability Resource

CERTS is working to accelerate meaningful opportunities for customers to participate voluntarily in competitive electricity markets. Studies focus on determining the effect on market efficiency of customer participation (demand response) and on demonstrating advanced demand-response technologies and strategies that will improve the reliability of the grid.

The components of this research include:

- Assessing the effectiveness of current ISO and utility programs designed to elicit demand response;
- Demonstrating price-responsive load control to provide ancillary services;
- Developing the technologies that enable price-responsive loads to participate effectively in energy markets—for example, sophisticated metering, communication, and control technologies that notify customers of load curtailments or high prices; tools that report near-real-time load data; and automatic controls to implement load responses.

Among the objectives of this research is the demonstration that loads such as municipal water-pumping systems and residential air conditioners, which have natural short-term energy storage capacity, can provide spinning reserve to the electricity system.

## KEY ACCOMPLISHMENTS:

- Demonstrating that large pumping loads can provide spinning reserve.
- Demonstrating that residential air conditioners can provide spinning reserve.
- Evaluated New York ISO demand response programs.
- Contributions to the design of ISO New England demand response programs.

“The NYISO is committed to implementing a variety of price-responsive load programs and to evaluating and refining them to ensure that they contribute to the overall performance of New York’s electricity markets. The evaluation of 2002 program experience will guide future program refinements.”

David Lawrence,  
Manager of Product  
Development at  
NYISO

## PROJECT HIGHLIGHT: NYISO Price-Responsive Load Program Evaluation

*How have markets performed in eliciting demand response? Is the response sufficient to improve market performance? If not, what else is needed?* CERTS is addressing these questions, in partnership with key stakeholders, by conducting market assessments of selected demand-response programs targeted to medium and large commercial and industrial customers. The objective is to evaluate key technologies that enable demand response; identify “best practices” among program administrators, contractors/aggregators, and end users; and analyze the technical, market, and institutional barriers that affect how widespread participation by large customer loads is likely to be in key regional electricity markets.

NYISO, in conjunction with the New York Public Service Commission, the New York State Energy Research and Development Authority, and regulated and unregulated load-serving entities and retail service providers, has implemented two large statewide demand-response programs. In partnership with these parties, CERTS is evaluating the effect that enabling technology has on customer demand reduction.

The analysis and results from these studies are being used to: identify major technical, market, and institutional barriers that inhibit widespread participation by different types of commercial and industrial customers in emergency and economic demand-response programs; prioritize additional R&D activities that could accelerate development of enabling technologies; and identify key issues that policymakers need to address to facilitate the long-run sustainability of demand-response service and technology providers.

*In New York's Day-Ahead Demand Response Program, customers or aggregators offer loads into the New York ISO's day-ahead market (upper curve). Depending on the prices offered, some of the loads get scheduled to displace generation (lower curve).*

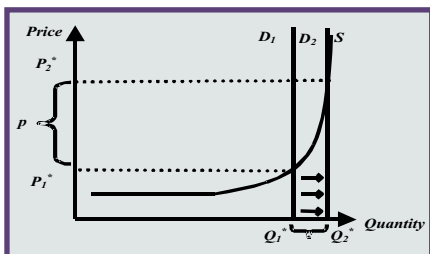
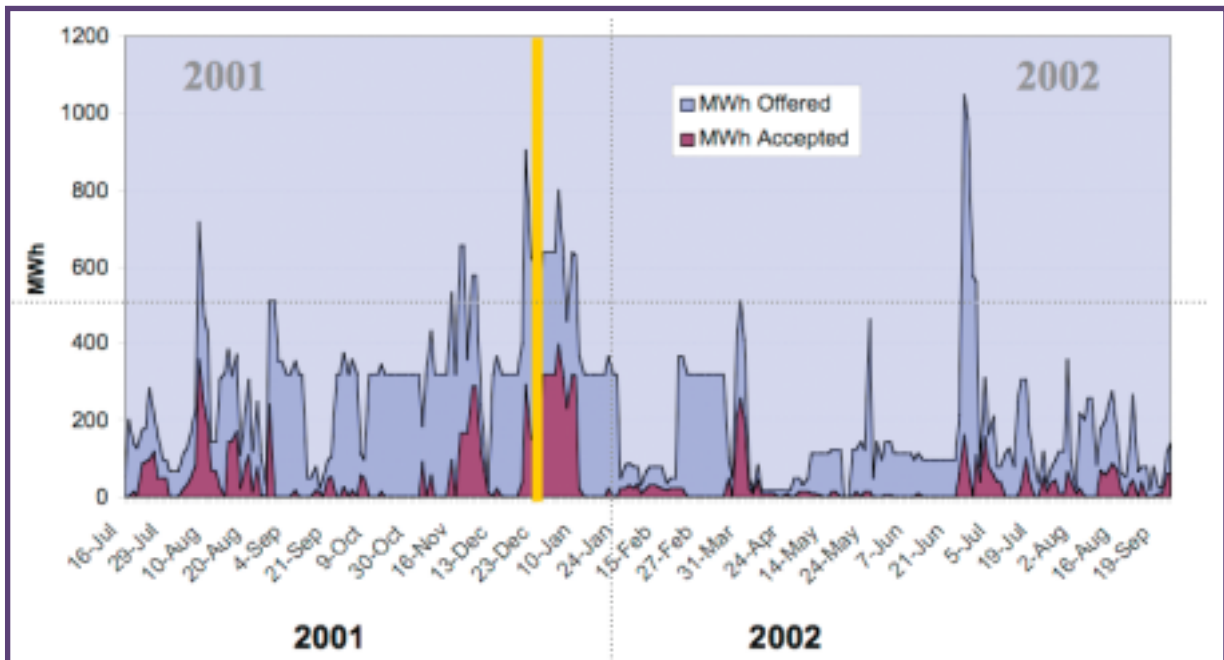

*Wholesale markets today serve inelastic (vertical) demands with increasingly expensive generation.*

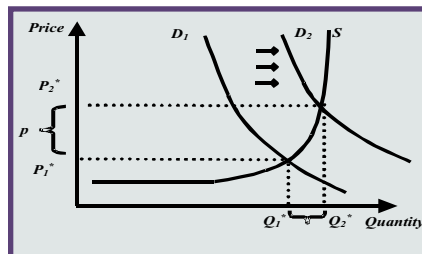

*Increasing demand elasticity lowers the cost of meeting loads, reduces frequency of high price spikes, and reduces ability of generators to exert market power.*



CERTS research on reliability technologies and needs has several objectives. It pinpoints emerging critical concerns that affect electric power system reliability, identifies technology R&D areas related to these critical issues, and facilitates planning for federal participation in this R&D. The issues studied by CERTS are public interest electricity reliability issues that are unlikely to be pursued by other participants in the electricity industry; they include:

- Determining the current health of the national electricity transmission grid and identifying strategies to address grid reliability;
- Developing effective real-time measures of electricity grid reliability and wholesale market efficiency;
- Assessing current bottlenecks in the national electricity transmission system and finding effective strategies to mitigate them;
- Testing a national program that monitors the quality and reliability of power supplied by the U.S. electricity grid as well as the economic impact of power outages; and
- Identifying technology needed for a future, smart, switchable electricity grid.

#### KEY ACCOMPLISHMENTS:

- Prepared *Grid of the Future* white papers in support of federal R&D planning.
- Completed study of the economic value of reliability.
- Participated in Secretary of Energy's Power Outage Study Team.
- Provided technical support for DOE's *National Transmission Grid Study*.

"The technical support provided by CERTS to DOE's *National Transmission Grid Study* was an enormous factor contributing to the *Study's* 51 recommendations to help modernize the U.S. electric transmission system to meet the needs of our 21st century economy."

Jimmy Glotfelty,  
U.S. DOE Office of  
Electric Transmission and  
Distribution

## PROJECT HIGHLIGHT: The National Transmission Grid Study

During the past 10 years, competition has been introduced into wholesale electricity markets with the goal of reducing costs to consumers. Today, wholesale electricity sales save consumers nearly \$13 billion annually. However, the nation's outdated transmission system was not designed to support today's competitive, regional electricity markets. Investment in the transmission system has not kept pace with the growth in generation and the increasing demand for electricity. Transmission bottlenecks threaten reliability and cost consumers hundreds of millions of dollars each year.

In May 2001, the National Energy Policy directed DOE to study the benefits of establishing a national electricity grid and to identify transmission bottlenecks and measures to remove them. DOE enlisted CERTS to provide technical support to the *National Transmission Grid Study*.

For this work, CERTS:

- Supported DOE's extensive, open, public-input process.
- Organized and prepared six issue papers from teams of nationally recognized experts on:
  - Transmission system operation and interconnection
  - Reliability management and oversight
  - Alternative business models for transmission ownership and operation
  - Transmission planning and the need for new capacity
  - Transmission siting and permitting
  - Advanced transmission technologies.
- Provided technical input and production support for the *National Transmission Grid Study*.
- Managed an independent analysis of U.S. electricity markets and identification of transmission system bottlenecks using DOE's Policy Office Electricity Modeling System.

Study documents can be downloaded from: <http://www.ntgs.doe.gov>

Since completion of the study, DOE has continued to rely on CERTS for technical support in carrying out study recommendations for federal action to identify and address transmission bottlenecks that affect the national interest.



The National Transmission Grid Study was published by Department of Energy in May, 2002.



DOE's National Transmission Grid Study made 51 recommendations on ways to facilitate investment in the Nation's transmission infrastructure to improve reliability and reduce electricity costs to consumers.

## Management Steering Committee

### **Vikram S. Budhraj, Chair**

Electric Power Group, LLC  
201 South Lake Avenue, Suite 400  
Pasadena, CA 91101  
Tel: (626) 685-2015  
Fax: (626) 685-2039  
budhraj@electricpowergroup.com

### **Marilyn Brown**

Oak Ridge National Laboratory  
P.O. Box 2008  
Oak Ridge, TN 37831  
Tel: (865) 576-8152  
Fax: (865) 574-7572  
brownma@ornl.gov

### **Carl Imhoff**

Pacific Northwest National Laboratory  
P.O. Box 999, MS K5-02  
Richland, WA 99352  
Tel: (509) 375-4328  
Fax: (509) 375-3970  
Carl.Imhoff@pnl.gov

### **Mark D. Levine, Vice-Chair**

Lawrence Berkeley National Laboratory  
1 Cyclotron Road, MS 90-3027D  
Berkeley, CA 94720  
Tel: (510) 486-5238  
Fax: (510) 486-5454  
mdlevine@lbl.gov

### **Marjorie Tatro**

Sandia National Laboratories  
1515 Eubank, SE, MS 0704  
Albuquerque, NM 87123  
Tel: (505) 844-3154  
Fax: (505) 284-5406  
mltatro@sandia.gov

### **Robert J. Thomas**

Power Systems Engineering Research Center  
Cornell University  
428 Phillips Hall  
Ithaca, NY 14853  
Tel: (607) 255-5083  
Fax: (607) 549-9812  
rjt1@cornell.edu

## Program Office

### **Joseph Eto, Manager**

Lawrence Berkeley National Laboratory  
1 Cyclotron Road, MS 90-4000  
Berkeley, CA 94720  
Tel: (510) 486-7284  
Fax: (510) 486-6996  
jheto@lbl.gov

## Industry Advisory Board Members

### **Paul Barber**

Barber Energy

### **Terry Boston**

Executive Vice President  
Tennessee Valley Authority

### **Rick A. Bowen**

Executive Vice President  
Dynergy

### **Vikram S. Budhraj**

President  
Electric Power Group

### **Jose Delgado, P.E.**

President and CEO  
American Transmission Company

### **Michel R. Gent**

President  
North American Electric Reliability Council

### **Glenn Files**

Senior Vice President  
American Electric Power

### **William Museler**

President and CEO  
New York Independent System Operator

### **Bruce A. Renz**

President, Renz Consulting LLC  
Consultant to American Electric Power

### **Marsha H. Smith**

Commissioner  
Idaho Public Utilities Commission

### **John D. Wiley**

Chancellor  
University of Wisconsin

### **Terry M Winter**

Chief Executive Officer  
California Independent System Operator

## Research Sponsors

Office of Electric Transmission and Distribution,  
U.S. Department of Energy



Public Interest Energy Research,  
California Energy Commission



## Research Partners

American Electric Power



North American Electric Reliability Council



Bonneville Power Administration



Northern Power



California ISO



Softswitching Technologies



ISO New England



Southern California Edison



Long Island Power Authority



Tennessee Valley Authority



New York ISO



This work was supported by the Assistant Secretary for Energy Efficiency and Renewable Energy of the U.S. Department of Energy, under Contract No. DE-AC03-76SF00098 and the California Energy Commission, Public Interest Energy Research Program, under Contract No. 400-99-012.

LBNL-52592