

Lawrence Berkeley National Laboratory

Recent Work

Title

GUIDELINES FOR INFILTRATION REDUCTIONS IN LIGHT-FRAME STRUCTURES

Permalink

<https://escholarship.org/uc/item/5xz995hq>

Authors

Diamond, R.C.
Grimsrud, D.T.

Publication Date

1981-09-01

c.2



Lawrence Berkeley Laboratory

UNIVERSITY OF CALIFORNIA

ENERGY & ENVIRONMENT DIVISION

Presented at the Forest Products Research Society,
"Performance of Light-Frame Structures", Denver,
CO, September 22-24, 1981

GUIDELINES FOR INFILTRATION REDUCTIONS
IN LIGHT-FRAME STRUCTURES

R.C. Diamond and D.T. Grimsrud

September 1981

RECEIVED
LAWRENCE
BERKELEY LABORATORY

OCT 2 1981

LIBRARY AND
DOCUMENTS SEC.

TWO-WEEK LOAN COPY

This is a Library Circulating Copy
which may be borrowed for two weeks.
For a personal retention copy, call
Tech. Info. Division, Ext. 6782

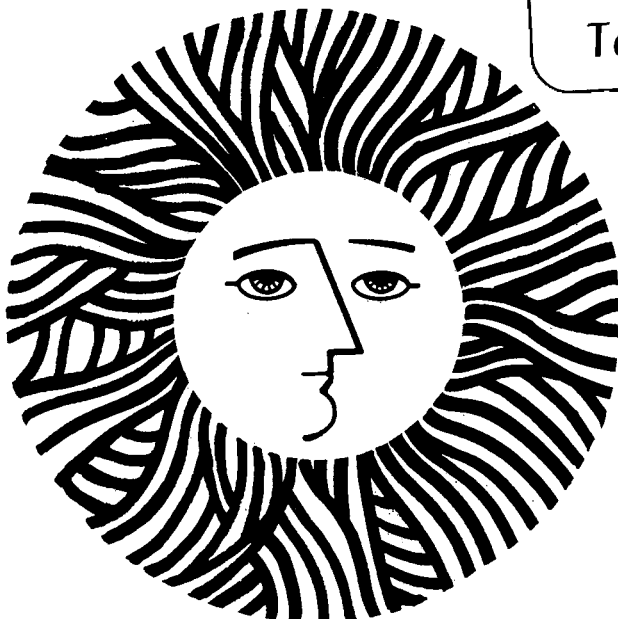

LBL-13231

c.2

DISCLAIMER

This document was prepared as an account of work sponsored by the United States Government. While this document is believed to contain correct information, neither the United States Government nor any agency thereof, nor the Regents of the University of California, nor any of their employees, makes any warranty, express or implied, or assumes any legal responsibility for the accuracy, completeness, or usefulness of any information, apparatus, product, or process disclosed, or represents that its use would not infringe privately owned rights. Reference herein to any specific commercial product, process, or service by its trade name, trademark, manufacturer, or otherwise, does not necessarily constitute or imply its endorsement, recommendation, or favoring by the United States Government or any agency thereof, or the Regents of the University of California. The views and opinions of authors expressed herein do not necessarily state or reflect those of the United States Government or any agency thereof or the Regents of the University of California.

Guidelines for Infiltration Reductions
in Light-Frame Structures

R.C. Diamond and D.T. Grimsrud
Energy and Environment Division
Lawrence Berkeley Laboratory
University of California
Berkeley, CA 94720

Abstract

Interest in reducing infiltration, i.e., the uncontrolled leakage of air into buildings, has intensified as energy costs increase. Reducing infiltration has other benefits as well as reducing energy use in buildings. Thermal comfort increases, noise transmission through the building envelope decreases, and moisture problems caused by convection of water vapor through leakage sites are reduced. In this paper we review field measurements of infiltration and techniques that designers and builders are currently using to reduce air leakage in residences. Since infiltration is generally the only source of ventilation air in residences we also discuss the relationship between tight buildings and indoor air quality.

The work described in this report was funded by the Assistant Secretary for Conservation and Solar Applications, Office of Buildings and Community Systems, Buildings Division of the U.S. Department of Energy under contract No. W-7405-Eng-48.

This manuscript was printed from originals provided by the author.

Introduction

The primary purpose of this paper is to provide home builders and others working in the building industry with an authoritative source of information for reducing infiltration in new construction. Specific construction techniques aimed at reducing infiltration are preceded by a commentary on the rationale and benefits of tighter house construction and a summary of the current tightness levels of the U.S. housing stock, based on a 300-house survey of infiltration measurements. Two case studies of energy-efficient houses are looked at both for the details of their construction and for the air quality in the finished houses. Finally, we provide a set of drawing details that illustrate specific techniques for reducing infiltration.

What is a Tight House?

The chief characteristic of a "tight" house is that it differentiates between infiltration and ventilation. Infiltration is the wind- and temperature- driven leakage of outside air through cracks and other openings in the shell of the house. Ventilation is the controlled exchange of inside/outside air necessary for maintaining indoor air quality, including removing odors from household activities, providing combustion air for furnaces, and carrying out excess moisture. In conventionally built houses, the air needed for ventilation is provided in a haphazard fashion by infiltration. In tightly built houses, where infiltration has been reduced to improve their energy-efficiency, other strategies are employed for ventilation.

Why Build Tighter Houses?

Because infiltration is a major source of thermal inefficiency in homes (accounting for 20-40 percent of all heat transfer through the building shell) reducing infiltration is a necessary step in reducing heating and cooling costs. Even in new construction where the thermal integrity of the structure has been improved by increasing the level of insulation, the potential for further energy savings from reducing

convective losses due to infiltration are substantial. In addition to making a house more energy-efficient, reducing infiltration results in a more comfortable house because it reduces drafts and noise levels inside--outside noises enter through the same leaks and cracks as infiltrating air. In northern parts of the country where humidity levels are often quite low in winter, tighter houses will maintain comfort conditions without the use of a humidifier. Tighter houses, however, will not guarantee lower energy bills. People ultimately determine how much energy is used in a house, but a tighter house will make it easier to use less energy.

Consumer demand for energy-efficient houses is at an all-time high, and buyers are increasingly aware of the energy features they want (1). Incentives for builders in some areas are available in the form of tax credits and utility financing. In California, builders have the option of claiming up to 40% of the cost of certain energy features through tax credits, or they can pass these on to the first buyer. Northern California utilities use a point system as a financial incentive to builders to include energy-conserving features in new construction. When active solar systems are installed it is particularly important that infiltration first be reduced, for by decreasing fuel needs, the size and cost of the system can be lowered. Nationally, a reduction of residential infiltration rates by 25% would significantly reduce peak-power requirements; the minimum savings to utilities would be of the order of 10-15 million kilowatts or, in terms of investment in power plants, a savings of \$10-15 billion.

How Tight is the Current Building Stock?

Tightness values for U.S. houses are often cited in the range of 1 to 2 air changes per hour (ach). For example, in a 1500 ft² house with 8-ft ceilings, 1 ach means 12,000 ft³ of air (about half a ton) leak into the house each hour. The first measurements of air infiltration in U.S. houses were taken in the late fifties from two houses in Illinois where the average infiltration rate was reported to be 0.62 ach (2). A recent survey of over 200 houses in the U.S. and Canada gives an average

infiltration rate for the five winter heating months, November through March, of 0.66 ach (3). While this survey is biased because of the high number of energy-efficient houses in the sample, i.e., houses that are of better than average construction quality, nevertheless, a value under 1 ach is clearly attainable through the use of conventional building construction practices.

How is Infiltration Measured?

Two basic techniques were used to measure air infiltration in U.S. houses. One technique is to release a small amount of tracer gas (a gas not normally present) into the house and to measure its concentration several times over a period of a few hours. The infiltration rate is then calculated from the rate at which the tracer gas is diluted by the infiltrating air. This measurement reflects whatever wind and temperature conditions are present at the time of the measurement. In the other technique, a large fan is installed in a doorway or window to blow air through the house at different indoor-outdoor pressure differences (fan speeds). Plotting the air flow through the house at the different pressures provides a leakage curve for the house that is independent of weather conditions. This leakage curve is used to calculate the leakage area of the house (a quantity that approximates the total area of openings in the shell) within the pressure range where infiltration normally occurs. In addition, fan pressurization allows individual leaks to be located by holding smoke sticks near suspected leakage areas while the house is pressurized. This simple procedure can also serve as a check for construction quality in determining if a house meets a targeted level of tightness. Builders in Sweden are required to make pressurization measurements to show their houses have a maximum leakage rate that corresponds to about 0.3 ach (4). Because occupants in a number of these houses experienced air quality problems and excessive humidity levels, the Swedish standard is currently under review. The new standards are likely to require mechanical ventilation or some method of air purification if infiltration is below 0.5 ach. (These control strategies are discussed later in the paper.)

What Makes a Tight House Tight?

The techniques for controlling infiltration have traditionally been to plug holes and cracks, weatherstrip, and generally pay attention to the quality of construction. In recent years, new materials for tightening house construction are being employed: foam plastic sealants that can be squirted into a crack like shaving cream where it expands slightly to ensure a tight seal; plastic sheeting instead of paper or foil insulation backing as a vapor barrier; and devices and techniques such as sill plate mastic; outside combustion air intakes for furnaces, water heaters, and fireplaces; duct taping; and exhaust vents with tightly closing dampers.

The single common factor among low-energy houses is the quality of work; that is, the attention to detail during construction. Not only must strict procedures be followed at each step during construction, but the proper sequence of steps must be maintained. For example, there is no reason for the carpenters to seal every crack during rough framing if the electricians and plumbers will later cut holes to accommodate their fixtures. In a recent LBL survey of 24 new houses in the San Francisco Bay area, we found that the careful application of a foam sealant to caulk all gaps in the rough framing did not reduce air leakage in the finished house because it was applied only once during the construction process (5). As examples of houses where air leakage was effectively reduced because of builders' attention to detail, we present two case studies--one, a dozen houses built by Modena Homes in Eugene, Oregon, and the other, fifty homes built by Ryan Homes in Rochester, New York.

Case Study: Modena Homes, Eugene, Oregon

In the spring of 1981, a four-man team from LBL performed air infiltration and air quality measurements on a group of 12 energy-efficient houses in Eugene, Oregon. These all-electric houses ranged in size from 900 to 1600 ft² and were built in 1976-1979 at prices comparable to others in the area. Nine of the twelve met the energy-efficient building standard set by the Eugene Water and Electric Board (6). These

standards apply to the type and installation of windows and doors, floors, walls, ceilings, placement and sizing of heating and cooling systems, installation of humidifiers, combustion air supply to fireplaces and wood stoves, plumbing, electrical systems, type of appliances, and building color. Insulation levels and weatherstripping were specified, and each house was thoroughly inspected at critical stages during construction to ensure compliance.

Several of the energy-conserving techniques used in these houses were originally developed for the Arkansas-style home (7), and included such specific features as magnetic weatherstripping on all exterior doors, furnace ducts inside the conditioned space, dehumidifiers, caulked plumbing penetrations, and continuous vapor barriers. The floor vapor barrier was a continuous 6-mil polyethylene sheet placed on top of the tongue-and-groove decking and below the floor underlayment. The ceiling vapor barrier was placed underneath the ceiling joists before the gypsum board was installed. A twelve-inch wide polyethylene strip was stapled over the top plate of each interior wall intersecting the ceiling vapor barrier. The weight of the ceiling insulation holds the plastic strip against the ceiling vapor barrier. The wall vapor barrier was stapled to the exterior wall framing and lapped over the floor and ceiling vapor barriers.

The finished houses were, on the average, more than 50% tighter than standard construction in a sample of 35 California houses (8). The calculated infiltration rate was 0.29 ach for the winter heating season, and 0.26 ach for the year. We concluded that the different leakage areas from one house to another were due to minor differences in the way they were constructed, and not to identifiable features common to all twelve houses. While smoke stick tests uncovered leaks in electric outlets, light switches, baseboards, windows and door framing, and mantelpieces, none could be considered excessively leaky.

In four of the twelve houses, the group measured indoor concentrations of radon, formaldehyde, and nitrogen dioxide. Radon levels were found to be insignificant. Nitrogen dioxide concentrations were low in all four houses, although levels in the two houses where occupants

smoked were slightly higher by comparison to the two houses without smokers. Moderately elevated formaldehyde levels were found in all four houses. Furniture and/or building materials are believed to be the source of this pollutant (9).

Case Study: Ryan Homes, Rochester, New York

In the spring and summer of 1980, fifty houses in Rochester, New York were tested for air leakage by two-man teams of students from Rochester Institute of Technology trained by LBL staff. Ten of the houses were subsequently tested for air quality by a group from LBL. The houses range in size from 995 to 2800 ft² (excluding basement), and were built in 1973-1980 at prices comparable to others in the area.

The houses built before 1976 had complete weatherstripping, but no vapor barriers, no sealant at wall joints and sole plates, little or no sealing of plumbing and electrical penetrations, and little quality control. The post-1976 houses were built to meet the specifications of Ryan Homes' "Standard Energy Package," which calls for vapor barriers in the walls, gasket material used at the foundation/sill plate junction, wind barrier paper used around ring joists, aluminum and wood windows set in a bed of caulk between the nailing flange and sheathing material with a 4" strip of wind barrier paper covering the nailing flange around the entire window perimeter, and outlet boxes and all holes for wire penetrations sealed with caulk. There were no vapor barriers or recessed light fixtures in the ceiling. Rigorous quality control was maintained in this group of 38 houses.

The specific leakage area in the post-1976 houses was 25% less than that of the pre-1976 houses. The average infiltration rate during the heating season was 0.73 ach for the pre-1976 houses and 0.52 ach for the post-1976 houses.

Ten of the houses were measured for indoor pollutants and relative humidity. The pollutants measured were formaldehyde, other aldehydes, radon, nitrogen dioxide, and particulates. Increases in indoor air pollutants were found to be negligible, even in houses where occupants

smoked. We concluded from this study that air quality does not deteriorate in tight houses as long as no major pollutant sources are present. (10).

Can a House be Too Tight?

Builders of tight houses must address the potential problems of controlling moisture, ensuring indoor air quality, and providing air for combustion appliances and fireplaces, each of which is discussed below.

Moisture Control

Over a 24 hour period, a family of four produces 20-30 pounds of water. About half of this is from moisture exhaled from the body, the rest is from cooking, bathing, laundry, and house plants. In winter, the interior surfaces of wall materials may become cold enough to cause water vapor to condense and accumulate in the framing and building materials. Ultimately, this may lead to deterioration of the wall materials, and will reduce the performance of most types of insulation. The installation of vapor barriers will prevent the flow of moisture-laden air into the structure. Tight houses will have higher moisture levels inside because of reduced infiltration levels and because common building materials--lumber, gypsum board, and concrete-- have high initial moisture content. Dehumidifiers are quite effective in removing excess moisture from the air. They can be placed wherever moisture is a problem, and can be used as needed. Dehumidifiers are standard features in new construction in some areas of the country (11). Spot ventilation, described in the next section on pollutant control, is another effective method for removing excess moisture.

Indoor Air Quality

All houses have some degree of indoor air pollution. People generate carbon dioxide, moisture, odors, and microbes through normal living processes. Other more important sources of indoor air pollution are combustion appliances (gas stoves, forced-air furnaces, unvented space heaters), building materials (glues, panels, insulation), furnishings (particularly with particleboard) and soil under and around houses. Among the pollutants commonly found indoors are carbon monoxide, nitrogen dioxide, formaldehyde, radon, and respirable (fine) particles.

The important point to remember is that while there are numerous sources of indoor air pollution, they are not all present in all houses. While infiltration rates in houses can vary by a factor of 10, the amount of pollutants produced can vary by a factor of 1000 from one home to another (12). It is this variation in source strength, rather than the difference in ventilation or air exchange rate, that is the dominant factor accounting for differences in indoor pollutant concentrations in U.S. residences. In houses that do have air quality problems, the pollutant source should be controlled regardless of the infiltration rate. Strategies for controlling indoor pollutants are:

Spot ventilation. This type of ventilation uses exhaust fans and is appropriate for pollution sources that are confined to a particular location (bathroom) or appliance (gas stove). Exhaust fans are used only while pollutants are being emitted (a few hours a day for a gas range hood), and they reduce the movement of pollutants into the rest of the house.

Windows. In mild weather, when heating and cooling systems are turned off, opening windows can provide adequate ventilation without wasting energy. Like exhaust fans, opening a window in the bathroom while showering or in the kitchen while cooking provides local ventilation; however, open windows are less effective than exhaust fans and allow pollutants to diffuse through the house.

Whole-house fans. In warm weather or warm climate zones, a whole-house fan can cool and ventilate the house much less expensively than an air conditioner. A whole-house fan is usually set into the ceiling or in a window where it exhausts warm house air. Such fans produce comfortable conditions in houses even when the outside temperature is above 80 °F. In winter, the fan should be removed from the window or sealed with a cover.

Mechanical ventilation with air-to-air heat exchangers. Another type of mechanical ventilation system -- not yet common in U.S. residences -- employs an air-to-air heat exchanger which, in winter, pre-heats the cold incoming (outside) air by transferring heat from the warm outgoing (inside) air such that 50-80% of the energy normally lost in the exhaust air is recovered. (This process works in reverse in the summer air-conditioning season.) In houses that have been tightened, such a system can be used very effectively to flush out indoor pollutants, without greatly sacrificing the energy-efficiency of the house.

A mechanical ventilation system with an air-to-air heat exchanger can be installed in a number of ways: in walls or windows, or as part of a central air system. Wall- and window-mounted units are the easiest to install. Unless there is good air movement throughout the house, however, a heat exchanger may ventilate only the room in which it is installed. Two or more may be required for a large house. Estimated cost is about \$250 per unit without installation. This type of installation resembles that of a window air conditioner. Some mechanical ventilation systems with heat exchangers intended to ventilate the entire house, are installed as part of the central air system. Installation costs vary widely depending on the amount of duct work to be installed. The estimated cost is between \$250 and \$800 without duct work.

Pollutant Filters. Filtering the air is another mechanism for reducing air pollution levels indoors. Pollutants such as radon daughters attach themselves to dust particles and other air impurities. For such pollutants, filtering the air is equivalent to removing the pollutant. Many appliances incorporate filters (e.g., furnaces and air conditioners often use fiberglass filters for particle removal and range hoods have

metal mesh filters for grease removal). These filters need to be cleaned or changed regularly in order to maintain their effectiveness. For the smaller, more harmful particles and for various other indoor air pollutants, many commercial filtration systems are available. Those described below are stand-alone units that can be found in most large appliance stores.

Electronic air filters. Electronic air filters, often called electrostatic precipitators, are very efficient at removing particles from the air. They are especially useful in homes where occupants smoke and combustion appliances are used. A typical unit is approximately 2 ft³ and can be placed anywhere in the house.

Fiber filters. Particle filtering units using high-efficiency fiber filters also remove particles from the air and are used much the same as electrostatic precipitators. While somewhat cheaper than electronic air filters, these units require more maintenance and are not as efficient.

Charcoal filters. Charcoal filters are usually incorporated in the above units but also can be purchased as free-standing units. Previously designed for removing indoor odors, they are also effective in removing carbon monoxide, formaldehyde, and certain organic chemicals common to houses.

Combustion Air

Tight houses should have some provision for supplying outside air to fuel-burning appliances. The furnace room should be sealed from the rest of the house with outside air ducted in. Local building codes and appliance manufacturer's specifications should be consulted for details.

Techniques for Reducing Infiltration:

The techniques described here have been chosen because they do not represent radical departures from current building practice. Several are already standard building practice in some parts of the country; others are recommended by building associations and product manufacturers.

Acknowledgment

The work described in this report was funded by the Assistant Secretary for Conservation and Solar Applications, Office of Buildings and Community Systems, Buildings Division of the U.S. Department of Energy under contract No. W-7405-Eng-48.

References

1. A recent survey by Professional Builder revealed that 80% of home buyers would pay \$600 more at the time of construction to cut heating and cooling bills by \$100 a year.
2. Bahnfleth, D.R., Moseley, T.D., and Harris, W.S. 1957. Measurement of infiltration in two residences, ASHRAE Trans. 63: 439-452.
3. Grimsrud, D.T., et al. 1981. A construction quality standard for air leakage in residential buildings. Lawrence Berkeley Laboratory (University of California) report, LBL-9416.
4. Svensk Bygnorm 1975, Statens Planverks Forfattningssamling, Liber Tryck Publications (Stockholm, Sweden, 1978), PFS 1978:1, 3rd ed.
5. Krinkel, D.L., LBL, (private communication, August, 1981)
6. Eugene Water and Electric Board, December, 1976. Energy efficient building standards. Eugene, Oregon.

7. Owens-Corning Fiberglas Corp. August, 1976. Energy saving homes: The Arkansas story, Pub. No. 4-BL-6958-D.
8. Grimsrud, D.T., et al, op cit.
9. Lipschutz, R.D., et al. 1981. Infiltration and indoor air quality in energy efficient houses in Eugene, Oregon. Lawrence Berkeley Laboratory (University of California) report, LBL-12924.
10. Offerman, F.J., LBL, (private communication, August, 1981)
11. Eugene Water and Electric Board, op cit.
12. Nero, A.V. Jr. January 17, 1981. Statement on indoor air quality presented to the California Energy Commission, Sacramento, CA.

Bibliography

1. California Energy Commission. 1980. Passive Solar Handbook. Sacramento, CA.
2. Central Mortgage and Housing Corp. 1977. The Conservation of Energy in Housing. Ottawa, Ontario. Canada.
3. Energy Research Development Corp. 1980. Energy Efficient Housing--A Prairie Approach. Saskatoon, Saskatchewan. Canada.
4. NAHB Research Foundation, Inc. 1979. Insulation Manual--Homes Apartments, 2nd ed. Rockville, MD.

5. Office of Technology Assessment. 1979. Residential Energy Conservation. Washington, D.C.
6. Oregon State Home Builders Assoc. 1981. Structural Energy Efficiency in Homes. Salem, OR.
7. Owens-Corning Fiberglas Corp. 1978. Guide to Constructing an Energy Efficient Home. Toledo, OH.
8. Ryan Homes. 1979 Specifications for Standard Energy Package. Pittsburgh, PA.

DETAILS

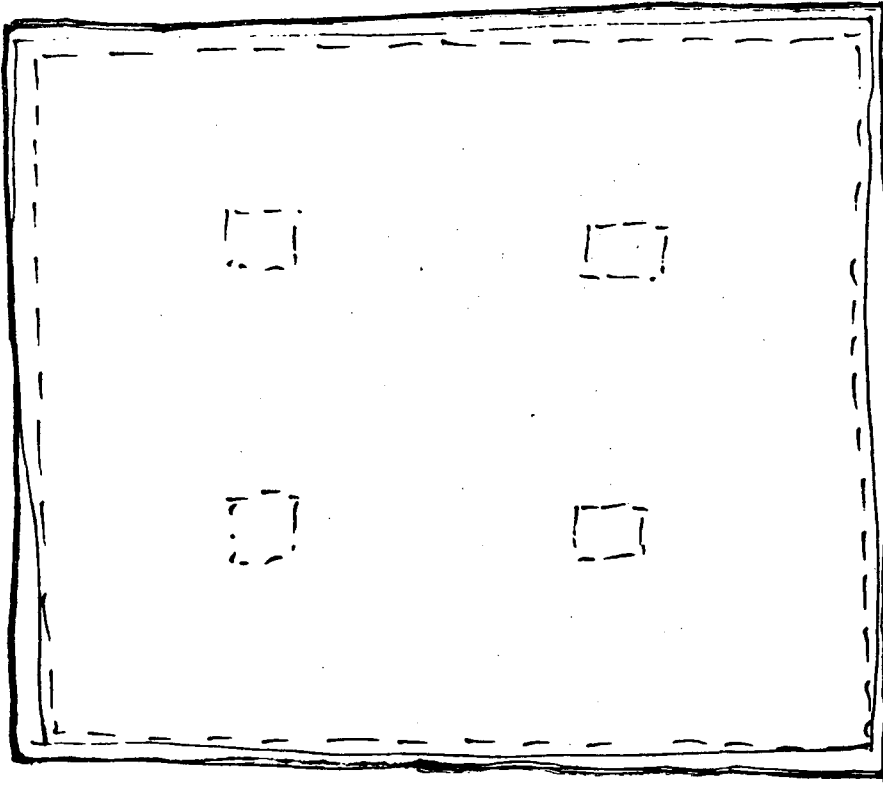

1

FOUNDATIONS

Detail 1: Foundations. Foundation slab or walls should be level, foundation diagonals equal, and corners square to reduce the potential for cracks and openings in the framing members which they support. This practice will avoid many subsequent construction problems and reduce infiltration.

DETAILS

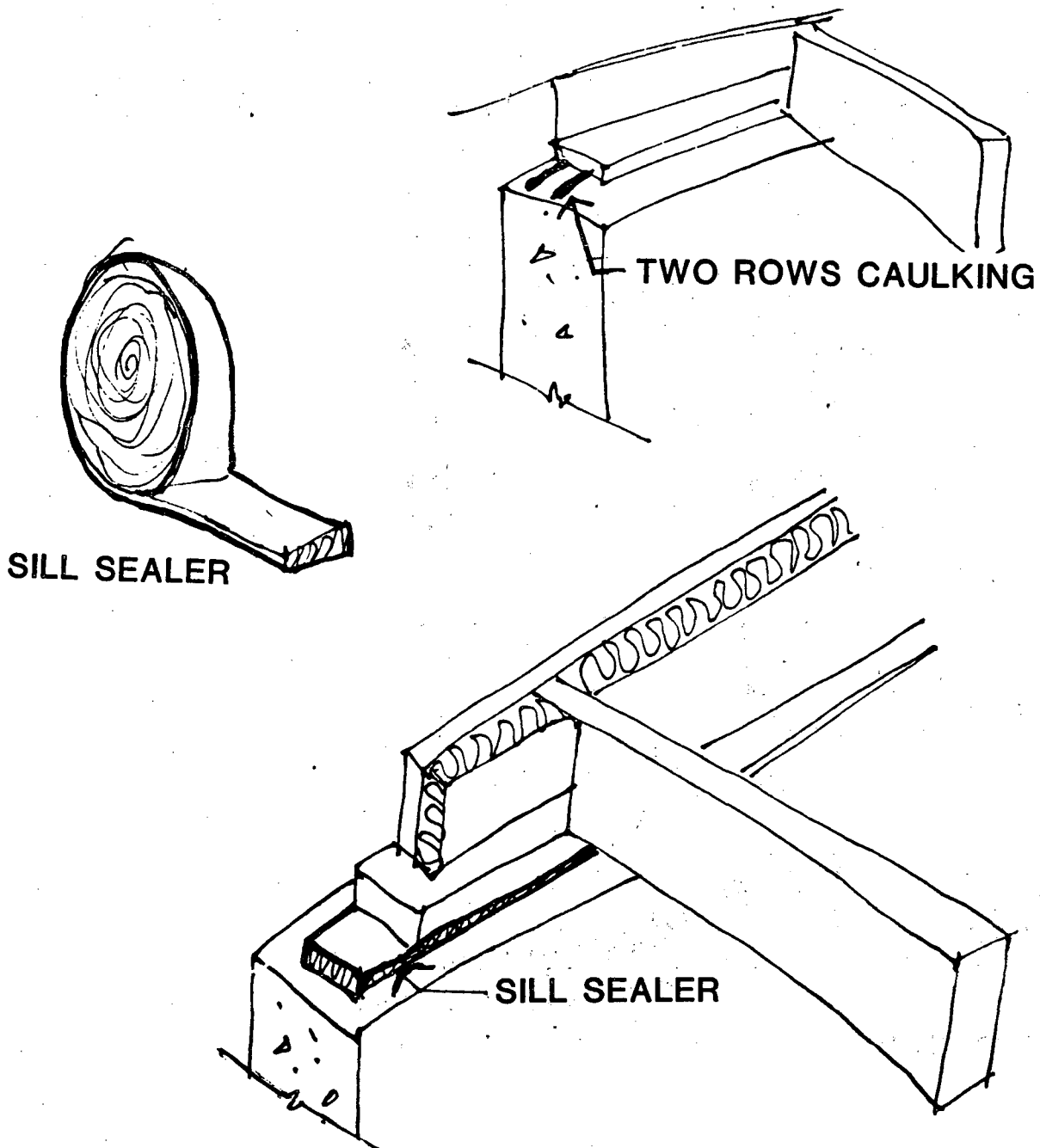

2

SILL SEALER

Detail 2: Sill Sealer. The interface between the top of the concrete foundation wall and the wood sill plate is a major source of air leakage. Sill sealer, a fiberglass strip about an inch thick, is unrolled on top of the foundation wall and temporarily taped in place, as necessary. A second technique is to set the sill plate on two beads of caulk to ensure a tight seal.

DETAILS

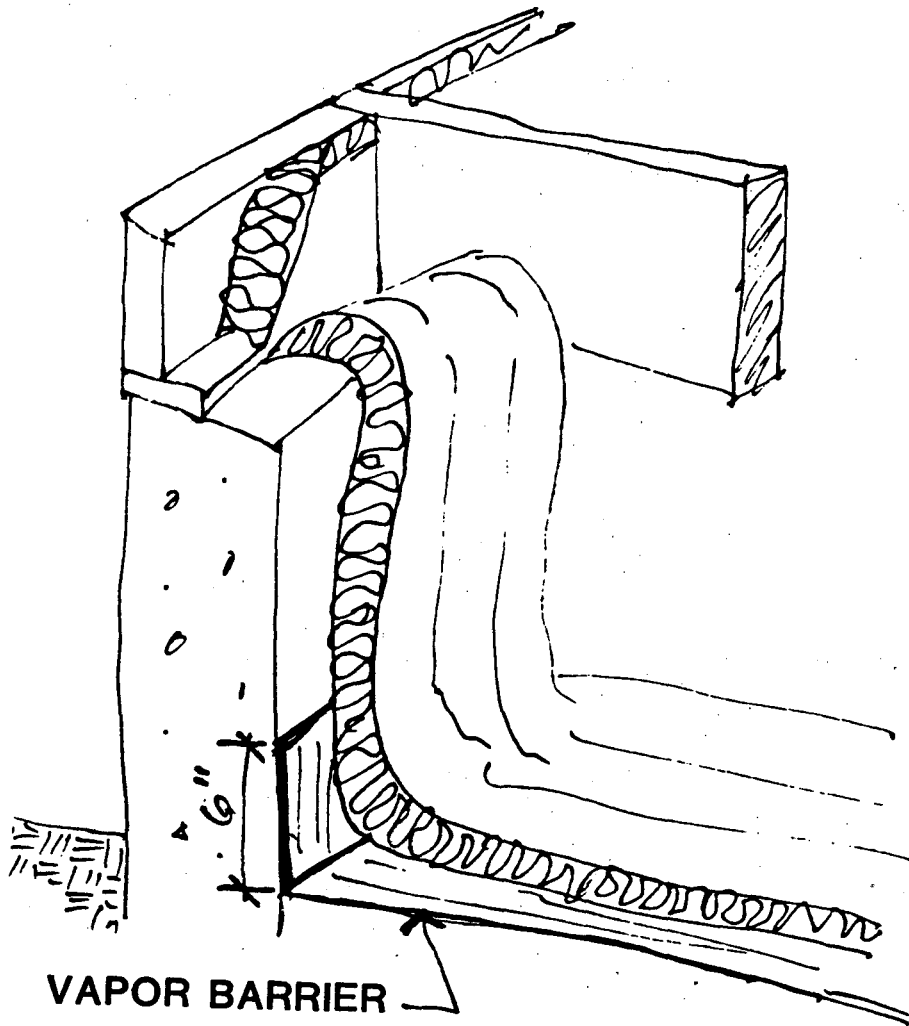

3

CRAWLSPACES

Detail 3: Unvented Crawlspace. Unvented crawlspaces should have a polyethylene vapor barrier on the ground with sheets overlapping by at least 12 inches and with taped seams. The vapor barrier should extend six inches up the perimeter walls and be securely taped. (Perimeter wall and band joists all need to be insulated.)

DETAILS

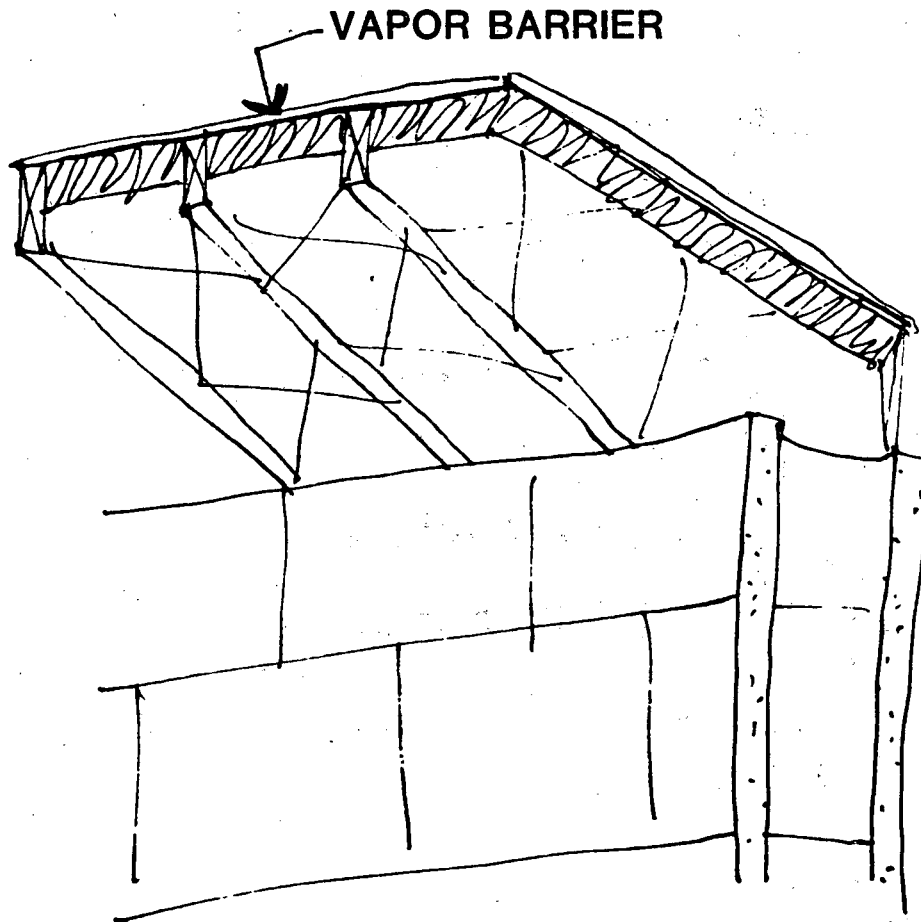

4

CRAWLSPACES

Detail 4: Vented Crawlspace. Vented crawlspaces can have batt-insulation installed between the floor joists, supported by wire laced back and forth on nails hammered into the underside of the joists. The vapor barrier goes on top of the insulation under the subflooring.

DETAILS

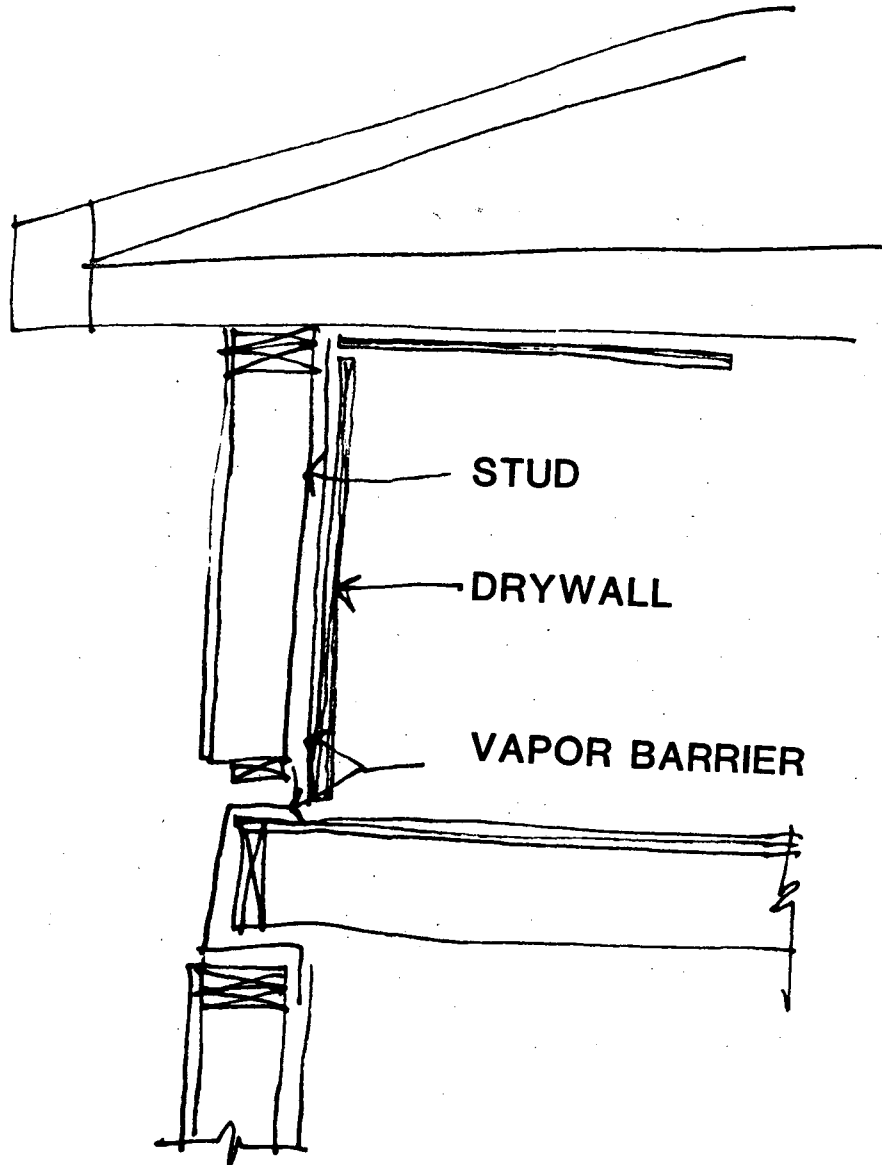

5

WALLS

Detail 5: Walls. All walls should have a polyethylene vapor barrier that extends 2" into the floor deck and into the underside of the floor joists or rafters above. Any openings or tears in the polyethylene must be repaired with tape. Wind barrier paper can be used on the outside of the band joists between floors.

DETAILS

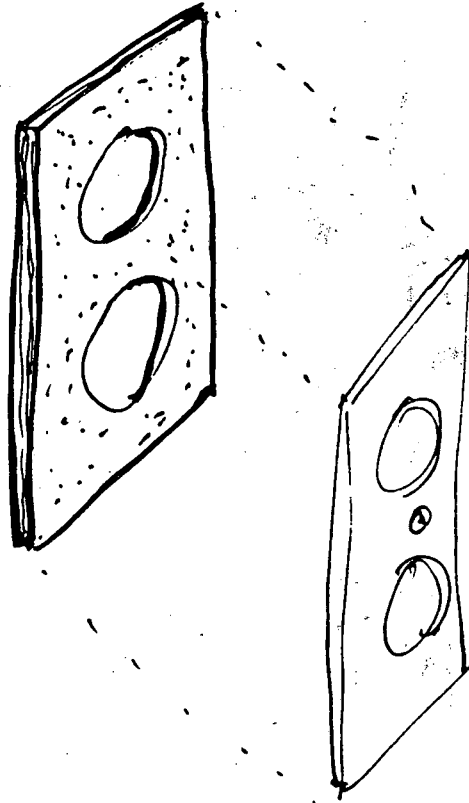

6

OUTLETS

Detail 6: Outlets/ Wiring. Foam gaskets can be installed behind outlet plates. Penetrations in exterior walls for electrical service can be minimized by bringing all the wiring in at one point.

DETAILS

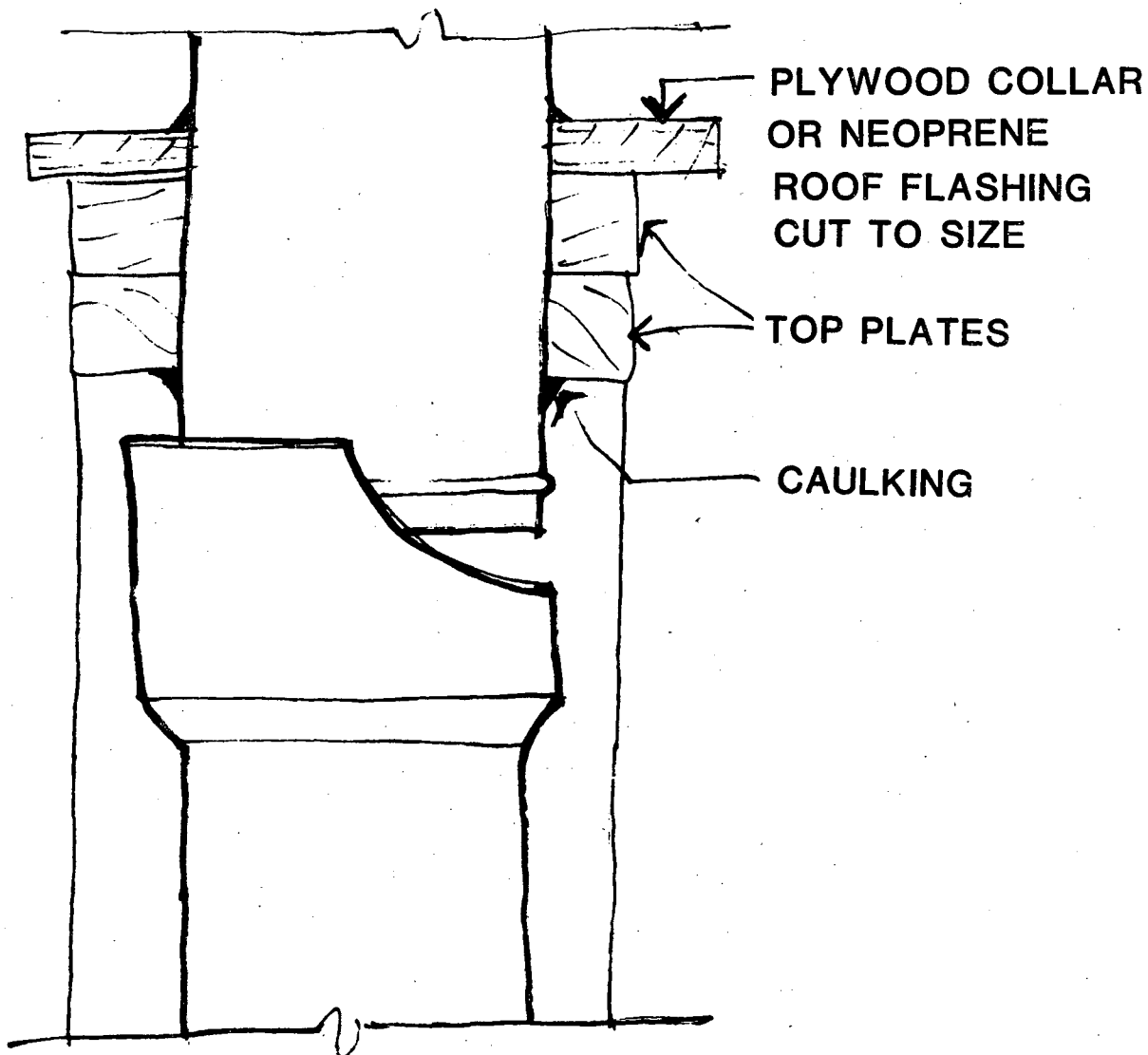

7

PLUMBING

Detail 7: Plumbing. Plumbing in exterior walls should be eliminated wherever the design will allow. Plumbing for sinks that are installed on exterior walls should run under the cabinet with the drain pipe rather than in the exterior wall cavity. Plumbing penetrations through the wall should be caulked or sealed with foam sealant. Holes cut for pipes to pass through the ceiling into the attic can act as paths for air leakage; these leaks often extend from the basement all the way to the attic. They can be sealed by stuffing fiberglass insulation in the openings around the pipes.

DETAILS

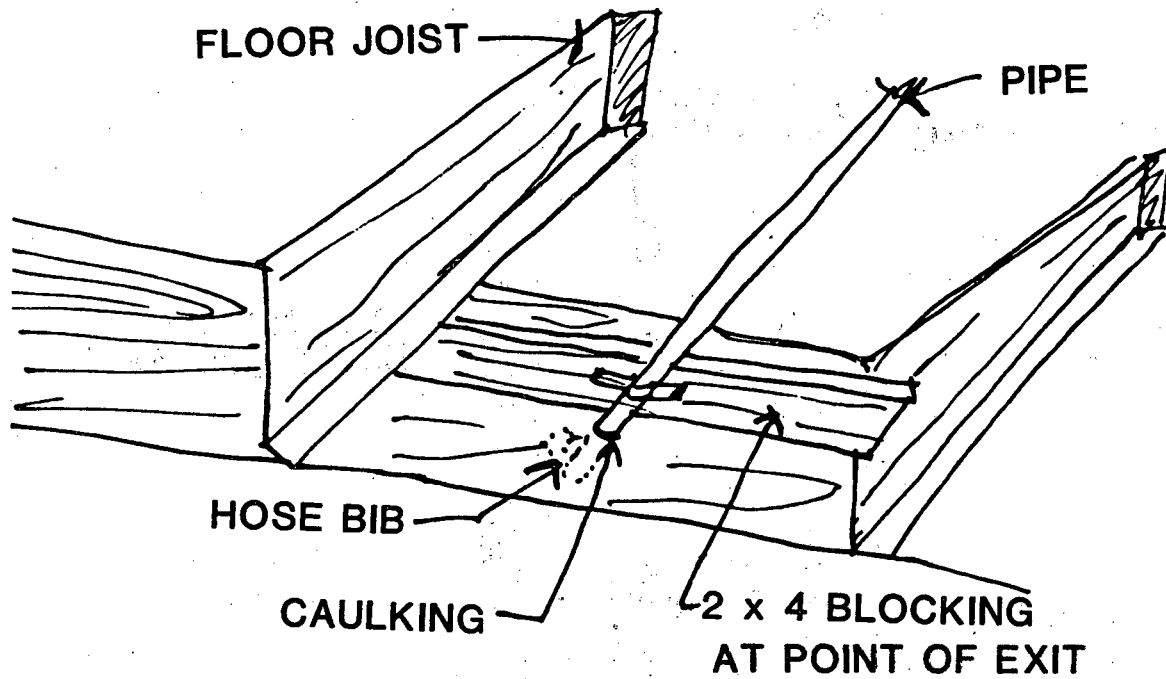

8

HOSE BIBS

Detail 8: Hose Bibs. Where pipes penetrate exterior walls, as in hose bibs, the pipe should be secured to a 2 x 4 blocking to prevent wearing at the point of exit. This joint should also be caulked.

DETAILS

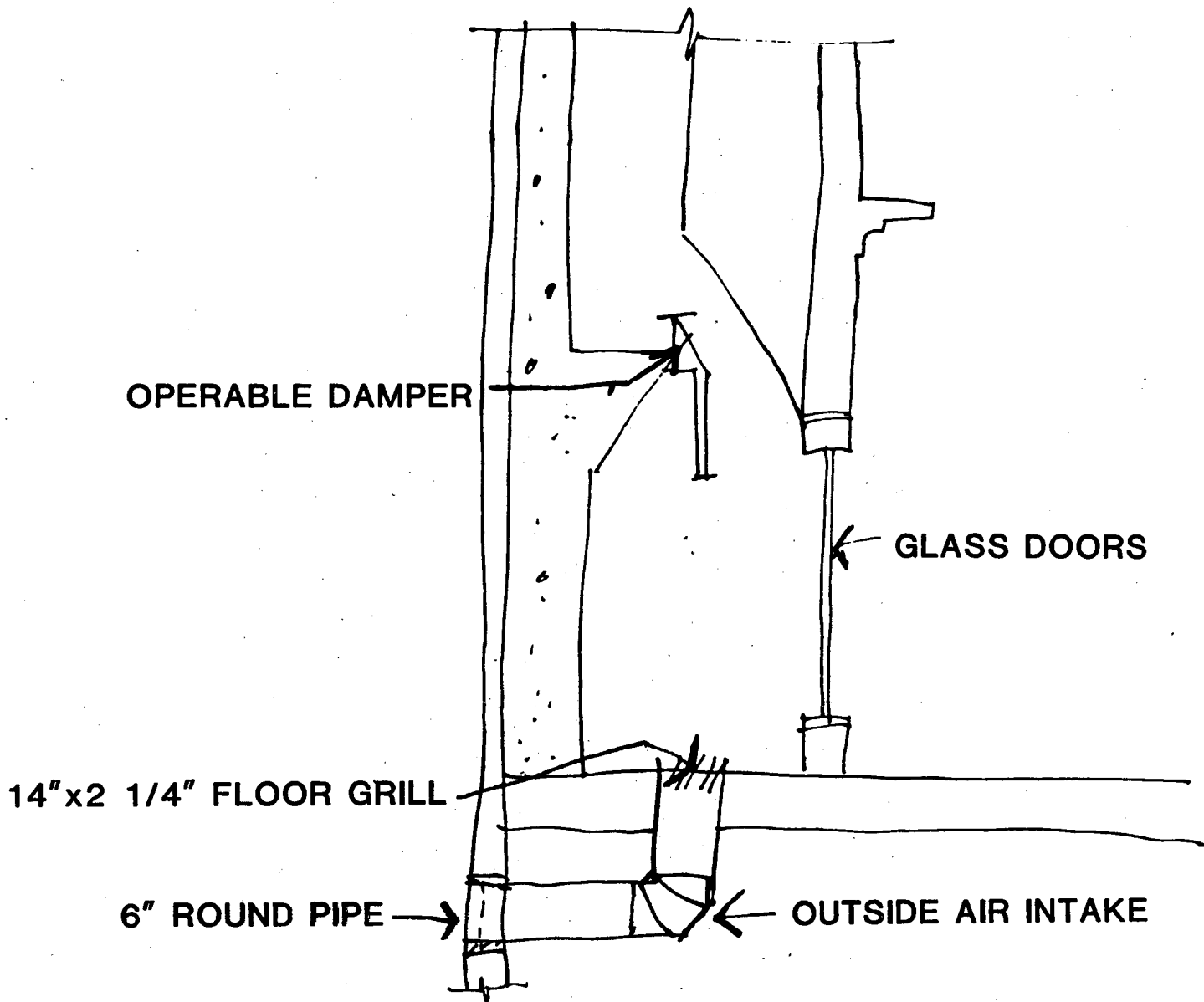

9

FIREPLACES

Detail 9: Fireplaces. Fireplaces are major sources of air leakage. Glass doors will help reduce infiltration whether or not a fire is burning. An outside air intake ducted from below with a tight sealing damper will help reduce drafts in the house. All joints where the fireplace penetrates finish material in exterior walls, floors, and ceilings should be caulked.

DETAILS

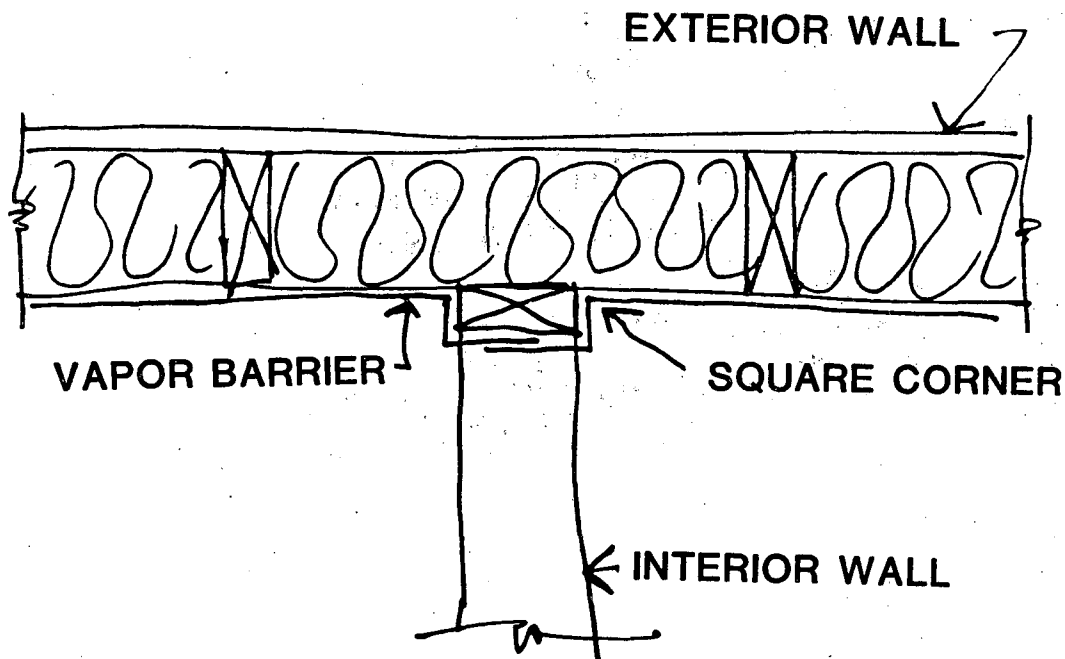

10

INTERIOR WALLS

Detail 10: Interior Walls. As shown in the drawing, the vapor barrier wraps around the face of the end stud in an interior wall. Provide a sharp fold at the corner for the drywall installation. Back-up clips can also be used instead of the traditional wood blocking to allow continuous insulation in the exterior wall.

DETAILS

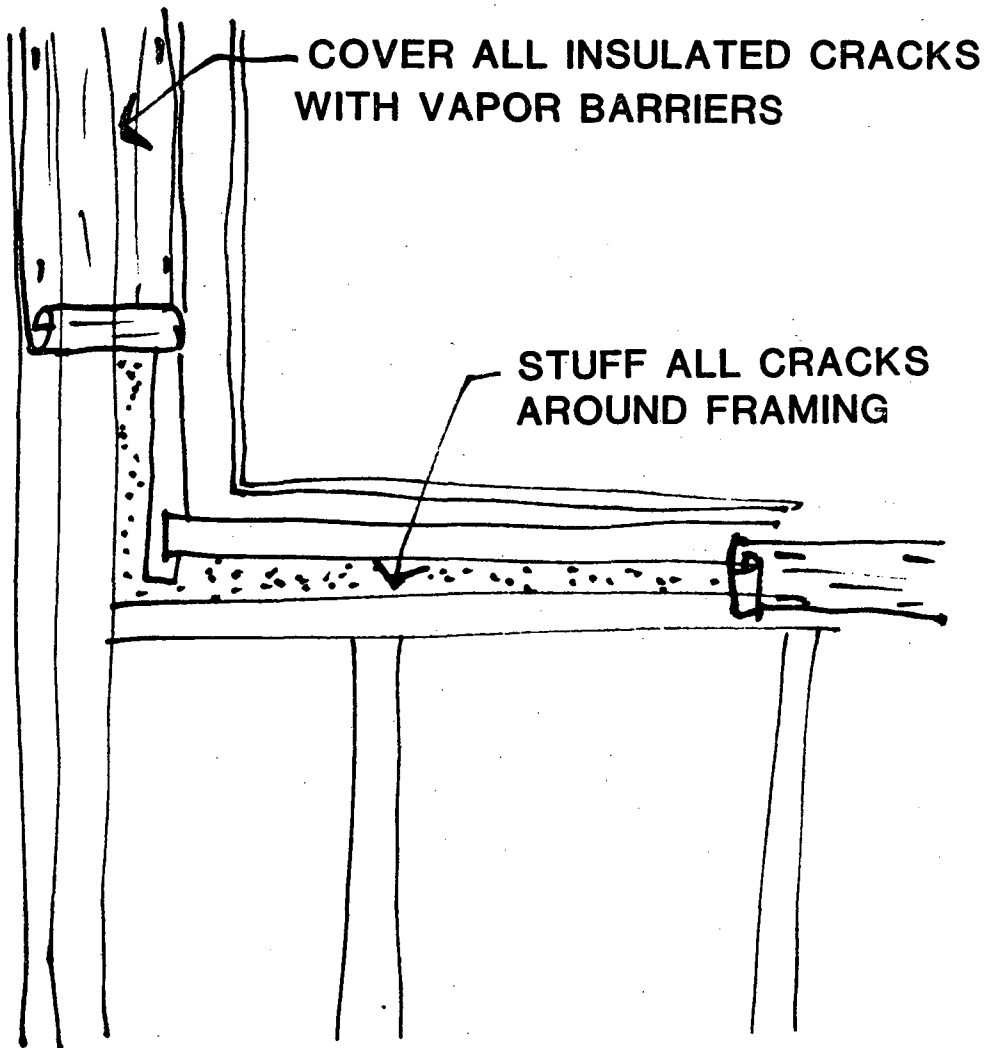

11

WINDOWS

Detail 11: Windows. Both the type of window and its installation play an important part in ensuring air tightness. Windows vary from the very leaky jalousie type, the moderately leaky double-hung type, to the casement and awning (or hopper) type, which are among the tightest. Proper installation calls for setting the window in a bed of caulk between the nailing flange and sheathing material. Any spaces around the frame should be filled with fiberglass insulation or foam sealant. Again, the wall vapor barrier should seal all the way around the perimeter of the window.

DETAILS

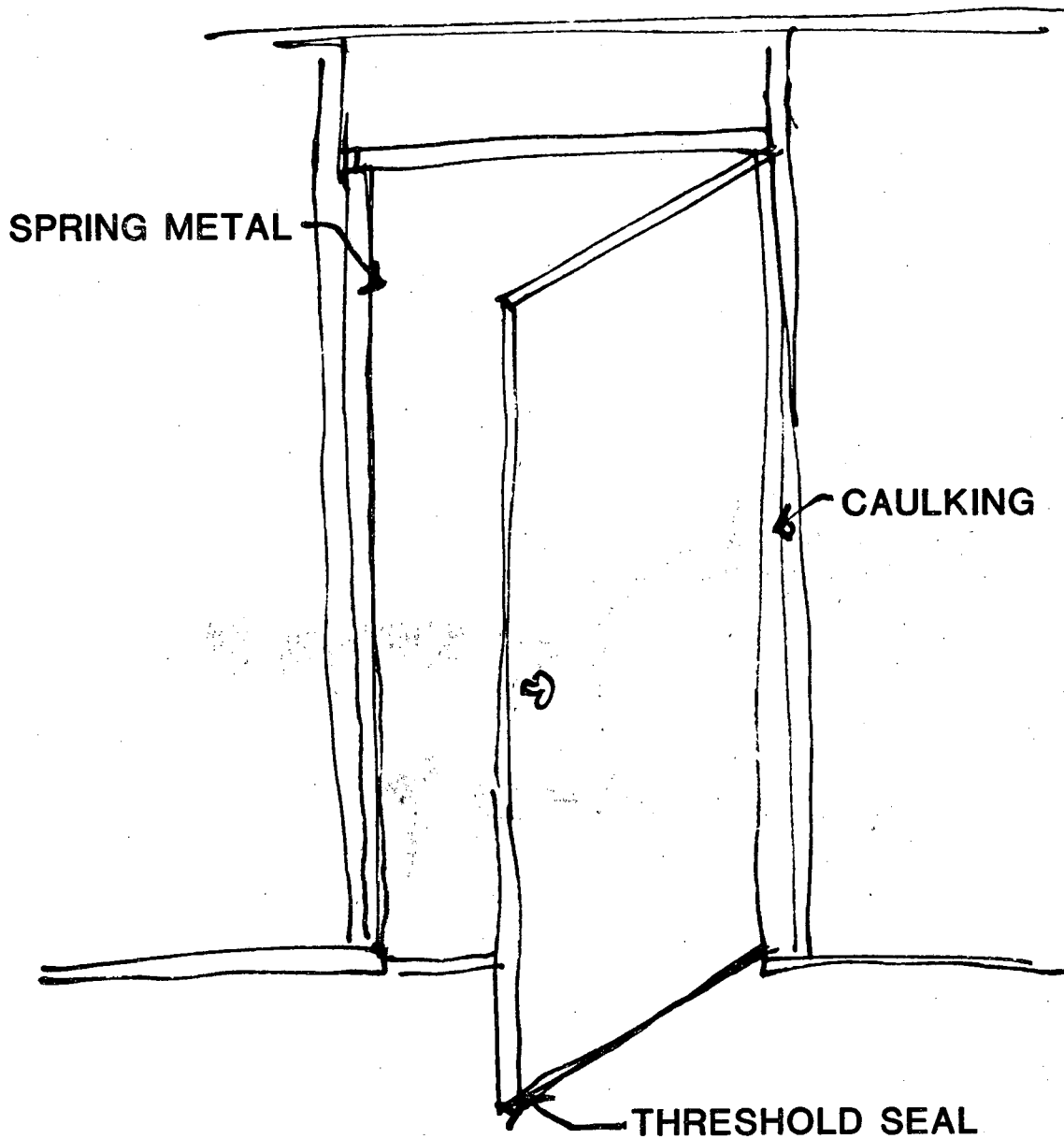

12

DOORS

Detail 12: Doors. Door framing should also have all spaces filled with insulation and sealed with the wall vapor barrier. Weatherstripping and sill thresholds are nearly standard practice; improved insulated doors have magnetic weather seals.

DETAILS

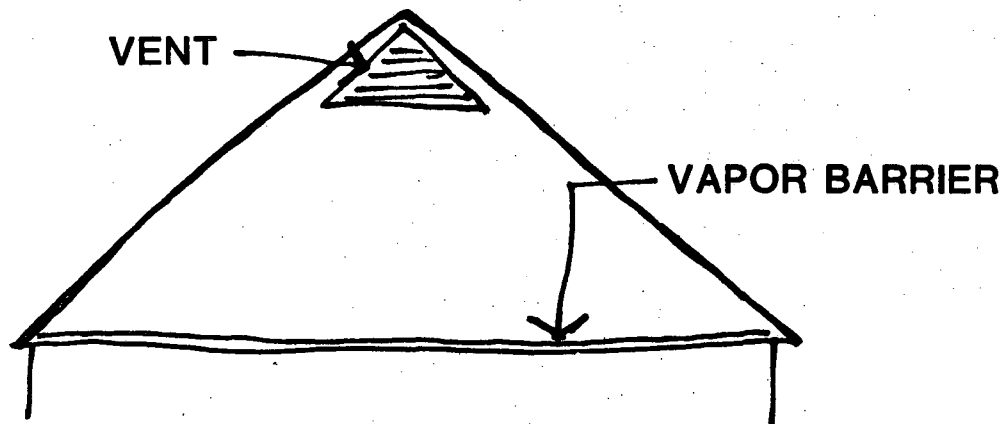

13

CEILING

Detail 13: Ceiling. In ventilated attic spaces a ceiling vapor barrier may not be necessary, for ventilation should be adequate to eliminate excess moisture without damaging the insulation. In flat or cathedral ceilings, however, it is difficult to provide ventilation, and vapor barriers should be installed.

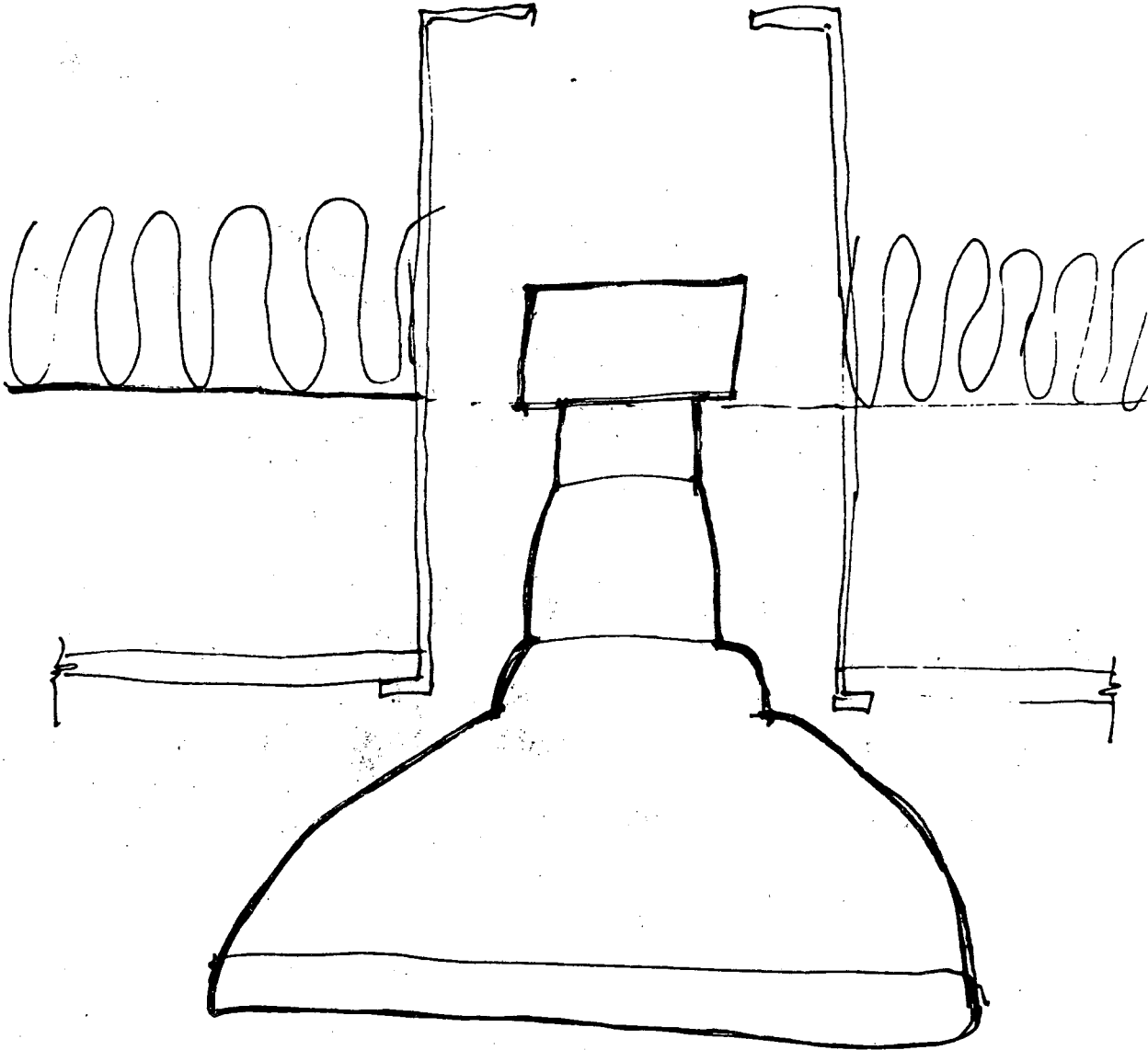

14

LIGHTING

Detail 14: Lighting. Avoid recessed or "bullet" lamps that penetrate into non-conditioned spaces such as attics. They cannot be insulated and can be large sources of air infiltration.

DETAILS

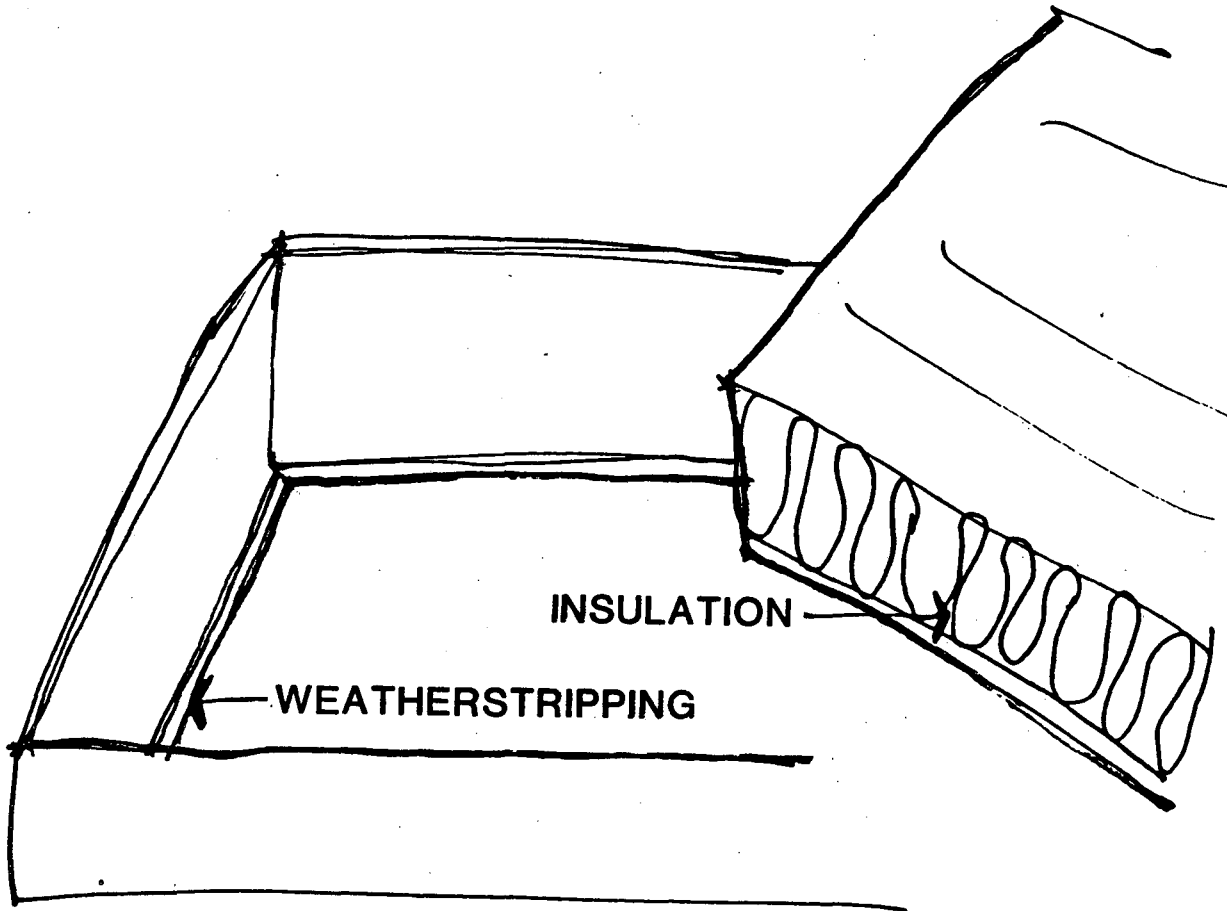

15

ATTIC ACCESS

Detail 15: Attic Access. Weatherstripping the access door to the attic reduces the warm air rising from the living area. This area is often overlooked because the leak is of warm air to the attic and is not felt by the occupants. (The back of the panel should be insulated at the same level as the rest of the ceiling.)

DETAILS

DO NOT VENT DIRECTLY
INTO ATTIC SPACE

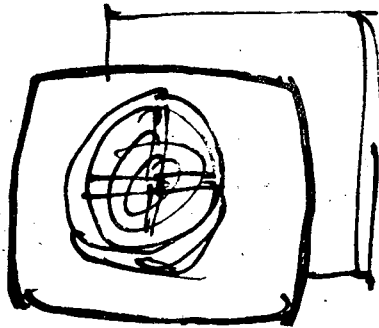
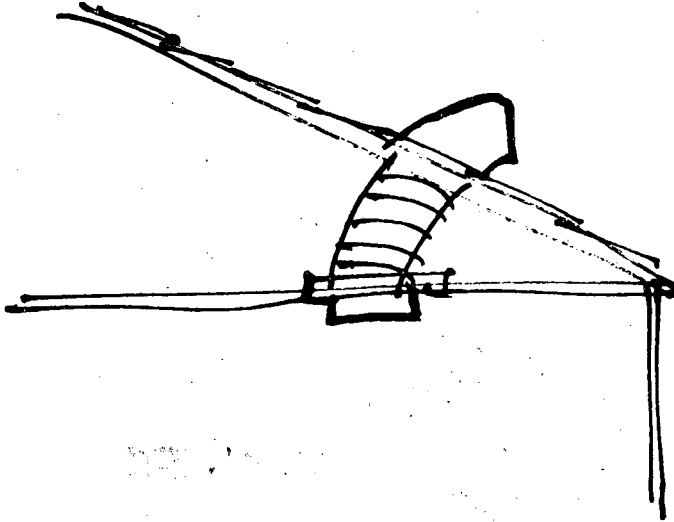

KITCHEN FAN

16

VENTS

Detail 16: Vents. Bathroom and kitchen vents that rely on gravity to seal often get stuck open because of corrosion, jamming, or wind pressure. Models should be selected that have a means of positive closure.

DETAILS

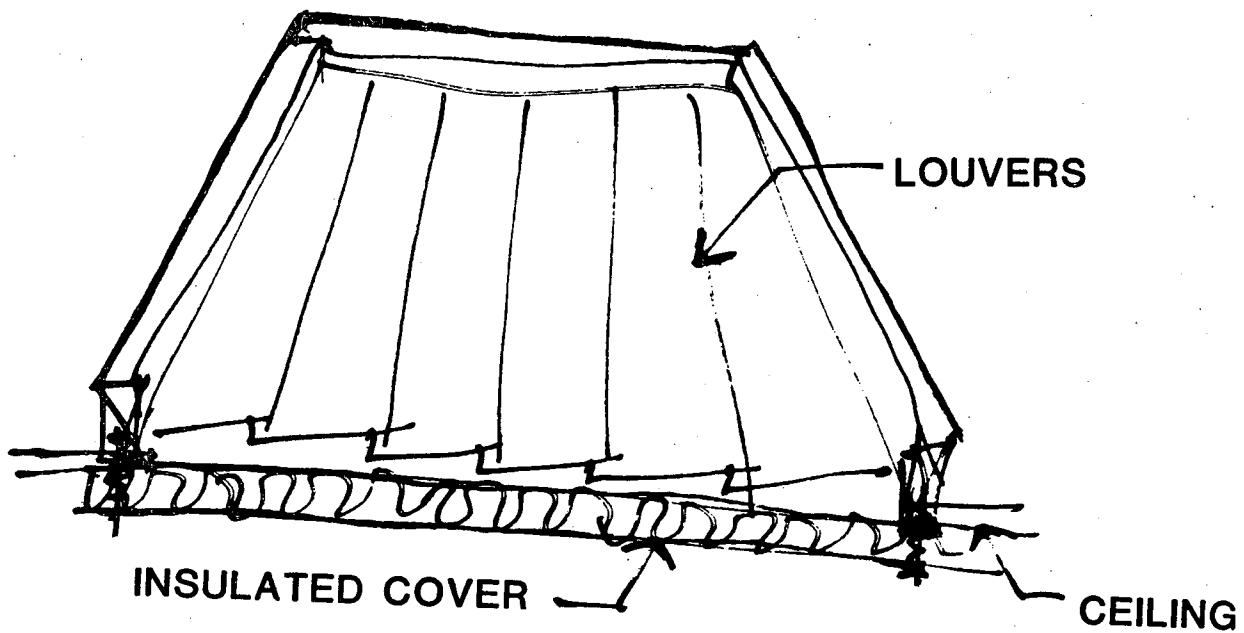

17 WHOLE-HOUSE FAN

Detail 17: Whole-House Fan/ Air Conditioner. Whole-house fans and window-mounted air conditioners are large openings to the outside. Window units should either be removed in winter, or covered securely. An insulated cover can be attached over the louvers of ceiling-mounted whole-house fans from the attic side of the fan.

DETAILS

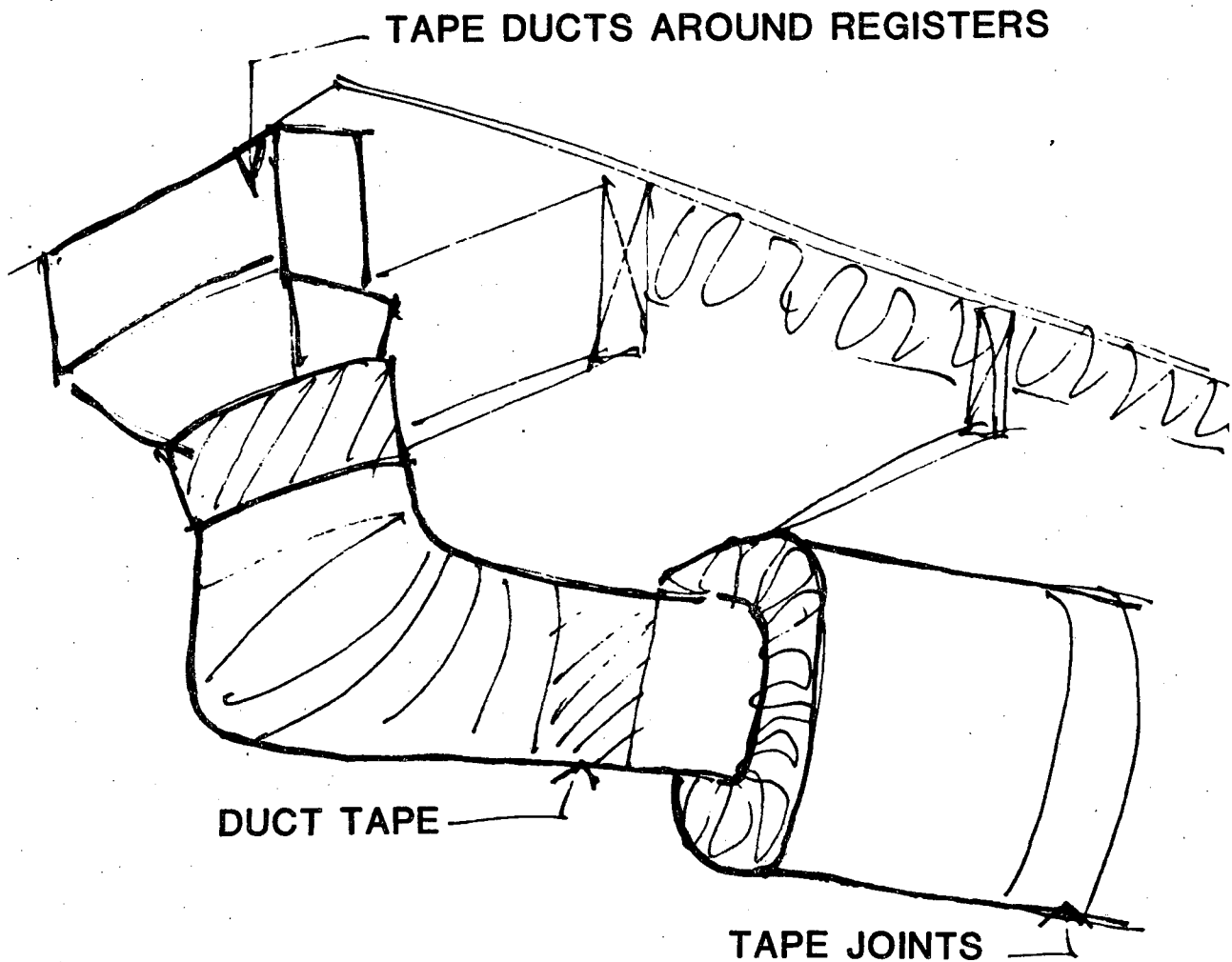

18

DUCTS

Detail 18: Ducts. Ducts can account for as much as 15% of the total house leakage. Leakage commonly occurs when ducts are not taped and/or when they do not sit properly on the mounting flanges of the registers. Duct leakage is especially critical when the ducts pass through unconditioned space, and there is a direct path for air from the furnace (or air conditioner) to the outside.

This report was done with support from the Department of Energy. Any conclusions or opinions expressed in this report represent solely those of the author(s) and not necessarily those of The Regents of the University of California, the Lawrence Berkeley Laboratory or the Department of Energy.

Reference to a company or product name does not imply approval or recommendation of the product by the University of California or the U.S. Department of Energy to the exclusion of others that may be suitable.

TECHNICAL INFORMATION DEPARTMENT
LAWRENCE BERKELEY LABORATORY
UNIVERSITY OF CALIFORNIA
BERKELEY, CALIFORNIA 94720