

**UCLA**

**UCLA Electronic Theses and Dissertations**

**Title**

Digitizing Conservation: incorporating digital technologies for the reconstruction and loss compensation of archaeological ceramics

**Permalink**

<https://escholarship.org/uc/item/5z099288>

**Author**

Burgess, Morgan Lyn

**Publication Date**

2018

Peer reviewed|Thesis/dissertation

UNIVERSITY OF CALIFORNIA

Los Angeles

Digitizing Conservation: incorporating digital technologies to the reconstruction and loss  
compensation of archaeological ceramics

A thesis submitted for the partial satisfaction of the requirements for the degree of Master of  
Arts in Conservation of Archaeological and Ethnographic Materials

by

Morgan Lyn Burgess

2018

© Copyright by

Morgan Burgess

2018

## ABSTRACT OF THE THESIS

Digitizing Conservation: incorporating digital technologies to the reconstruction and loss  
compensation of archaeological ceramics

by

Morgan Lyn Burgess

Master of Arts in Conservation of Archaeological and Ethnographic Materials

University of California, Los Angeles, 2018

Professor Christian Jean Mar Fischer, Co-Chair

Professor Willemina Z. Wendrich, Co-Chair

This research looks at the ways in which digital technologies have been applied to the study, display, and conservation of cultural heritage objects. The experimental methodology is informed by existing applications of these technologies and sequentially applies data acquisition techniques, three-dimensional digital modeling, and three-dimensional printing as an approach to the conservation of a fragmented and incomplete ceramic vessel. Triangulation laser scanning and structured light scanning were used to generate a digital mesh and computer-aided design model for each sherd. MeshLab and Blender software programs were used to digitally reconstruct the ceramic fragments. The loss within the digitally reconstructed ceramic body was filled in Blender and 3D printed in a polylactic acid plastic filament. This proposed process was performed by a non-specialist in digital techniques but yielded promising results. The experimental process can be used a platform from which to build on the applications of digital techniques in the conservation of cultural heritage objects.

The thesis of Morgan Burgess is pending approval from Chris Johanson.

Chris Johanson

Christian Jean Mar Fischer, Committee Co-Chair

Willemina Z. Wendrich, Committee Co-Chair

University of California, Los Angeles

2018

I would first and foremost like to thank my advisor and committee co-chair, Professor Christian Fischer, for his continued support of my research and his patience as I stretched beyond my comfort zone and tested technologies and methods new to me. Secondly, I would like to thank my committee members: Professors Willeke Wendrich (co-chair) and Chris Johanson, the department of the Conservation of Archaeological and Ethnographic Materials: Professors Ioanna Kakoulli, Ellen Pearlstein, and David Scott (since retired), and Conservation Specialist & Lecturer Vanessa Muros. A special thank you to my classmates, all of whom have impacted me personally and professionally; to Deidre Whitmore of the Digital Lab at the Cotsen Institute of Archaeology, Doug Daniels from the Digital Humanities Lab, and Walker Riley from the University of Texas at Austin for their respective assistance in my experimental process. And, finally, thank you to my family and partner for their undying love and support.

## TABLE OF CONTENTS

<b>1. INTRODUCTION</b>	<b>1</b>
<b>2. RESEARCH SCOPE AND OBJECTIVES</b>	<b>2</b>
<b>3. 3D TECHNOLOGIES AND HOW THEY WORK</b>	<b>3</b>
<b>3.1 Data Acquisition</b>	<b>3</b>
3.1.1 Structure from Motion	4
3.1.2 Laser Scanning	5
3.1.3 Structured Light Scanning	6
<b>3.2 The Generation of a 3D Model</b>	<b>7</b>
<b>3.3 3D Printing &amp; Manufacturing</b>	<b>8</b>
<b>4. 3D DIGITAL TECHNOLOGIES IN CULTURAL HERITAGE DISCIPLINES</b>	<b>11</b>
<b>4.1 Museums and Education</b>	<b>11</b>
<b>4.2 Advantages of Digital Models in Archaeology &amp; Art History</b>	<b>14</b>
4.2.1 Remote Access to Cultural Heritage Sites and Objects	14
4.2.2 Digital Restoration as an Art Historical Tool	15
<b>4.3 Digital Technologies in Conservation</b>	<b>18</b>
4.3.1 Digital Reconstruction of Fragmented Objects	18
4.3.2 3D Printing to Assist Display and Treatment	24
<b>5. MATERIALS, METHODS, &amp; TECHNOLOGIES</b>	<b>27</b>
<b>5.1 3D Data Acquisition</b>	<b>30</b>
5.1.1 3D Laser Scanning	30
5.1.2 Structured Light Scanning	31
<b>5.3 Digital Reconstruction</b>	<b>33</b>
<b>5.4 3D Printing</b>	<b>33</b>
<b>6. RESULTS</b>	<b>34</b>
<b>6.1 Data Acquisition</b>	<b>34</b>
<b>6.2 Digital Reconstruction</b>	<b>38</b>
6.2.1 Reassembling Fragments in MeshLab	38
6.2.2 Reassembling Fragments in Blender	39

<b>6.3 3D Printing</b>	<b>44</b>
<b>6.4 Conservation Applications and Challenges</b>	<b>44</b>
<b>7. CONCLUSIONS</b>	<b>47</b>
<b>BIBLIOGRAPHY</b>	<b>49</b>



## 1. Introduction

Since the advent of the digital era, the application of new digital technologies within cultural heritage related fields has proven beneficial for the continued study, exhibition, preservation, and conservation of cultural heritage objects. One needs to look no further than digital photography to see the positive impact new technologies can have in cultural heritage related fields; digital photography has facilitated easier file sharing, increased access to information, and the accurate display of condition, environment, and conservation treatment(s). With the rapid development of new digital three-dimensional (3D) technologies, 3D models have the potential to compound on the scholarly impact of 2D files (Scopigno, Callieri, et al. 2011). Digital technologies continue to grow in popularity as they become more accessible and user-friendly, therefore innovations in their use and application are continually expanding. As a result, digital models of cultural heritage objects have become a valuable tool in museum studies and display, archaeological and art historical study, and conservation (Berndt and Carlos 2000; Pintus, et al. 2014; Guidi, Beraldin and Atzeni 2004; Scopigno, Callieri, et al. 2011). Such technological advancements have made it possible for the procurement and storage of digital 3D files even on personal computers and laptops – though entirely dependent on the processing capabilities of the respective computer, thus the use of large 3D files have become a viable option for individuals as well as institutions (Pieraccini, Guidi and Atzeni 2001).

An investigation into the applications of digital technologies in cultural heritage fields has revealed substantial differences due to the varied requirements and desired outcomes of each respective project. Approaches to digitization differ in three core areas: data acquisition, processing software and procedures, and 3D printing. Three-dimensional models can be generated with everything from a series of 2D files and the right software to high-tech laser scanning equipment. Digital models can be viewed in numerous software programs ranging from freely available open-source shareware to expensive proprietary software subscriptions.

Once created, a 3D model can be printed in (with) various materials. Differences in technology do not necessarily have a great impact on the outcome of a project. However, understanding the processes and variability of data acquisition, digital modeling, and 3D printing methods is crucial in making decisions regarding their respective applications to a new project.

## 2. Research Scope and Objectives

The overarching goal of this project was to assess the ability of current digital technologies, data acquisition, model generation and modeling, and 3D printing, to assist in the treatment of an incomplete and fragmented ceramic object by a typical conservator who is a non-specialist in the imaging and computer science fields. Many 3D capture, reconstruction, and reproduction approaches involve the use of sophisticated and expensive equipment and collaboration with computer scientists to write specific code and algorithms, neither of which are necessarily available to the average conservation lab nor applied to the routine treatment of ceramics.

The initial phase of the project involved a detailed overview of recent applications of 3D technologies and applications in order to provide an overview of the field. Information regarding how digital models are created was broken down into three categories: data acquisition, digital processing, and 3D printing. The different approaches were then evaluated to determine which were most applicable to the conservation of a fragmented and incomplete ceramic, specifically focusing on the reassembly and loss compensation of a terracotta pot. This project investigated two techniques of three-dimensional data acquisition (laser scanning and handheld structured light scanning), two free, open-source modeling programs (MeshLab and Blender), and 3D printing with a fused deposition modeling 3D printer. The goal was to create a step-by-step process to digitally tackle reconstruction and loss compensation that could easily (relatively speaking) be applied by a conservator without an in-depth understanding of digital technologies.

### 3. 3D Technologies and How They Work

The sheer amount of difference in the application of digital technologies amongst projects that utilize 3D digital models of cultural heritage objects is overwhelming as those respective applications vary based on the requirements and desired outcomes of any given project and the research specifications of the user. A researcher's choice of technology and method is dependent upon many factors such as budget, the size of an object or site, the required level of detail, and the materiality of an object and affect the choices involved in selecting appropriate methods in the following ways:

1. Budget: 3D acquisition technology and computer processors differ in cost and these choices can ultimately affect the resolution and fidelity of a 3D model.
2. Size and shape: this can range from a small singular artifact to a large archaeological site with multiple features.
3. Detail and resolution: the accuracy of a 3D model and the level of surface detail is dependent upon the project requirements and will greatly impact file size.
4. Materiality: the same technique applied to a reflective surface and a matte surface will yield very different results.

These four factors are paramount in determining how 3D models will be acquired and the applications necessary for post-processing. "Budget" is listed first since it singularly affects which technologies a team/researcher can use. The following three factors more specifically determine the data acquisition method. Further processing of the acquired models is, again, dependent on the research specifications and desired outcomes.

#### 3.1 Data Acquisition

The generation of a 3D model involves the accurate capture of an object's geometry. Regardless of technology type, this process requires a light source and a sensor or detector. The current popular methods of generating 3D models are split into two broad categories: passive and active. In each and every approach that falls within these two categories, the objective is the accurate calculation of points detected on the surface of an object to generate a point cloud from which a 3D model can be constructed (Soile, et al. 2013; Guidi, Beraldin and Atzeni 2004). Passive methods use diffuse or ambient light to capture a series of 2D images

which are overlaid at discrete concurrent points to create a three-dimensional model; active methods project light(s) onto the surface of an object and a sensor(s) measures the deformations in the projected light (Jecić and Drvar 2003).

The most frequently used data acquisition methods for the generation of digital 3D models of cultural heritage are structure from motion (SfM), laser scanning, and structured light scanning. These methods tend to create the most accurate digital meshes for close range applications and the scanning of singular objects of moderate size (Jecić and Drvar 2003). Structure from Motion is a *passive* method; it does not actively project light onto an object but uses diffuse light, 2D capture. SfM software matches pixels from the 2D images to create a point cloud where each point is defined by x, y, and z coordinates. Color and texture information is layered onto the point cloud to complete the 3D model. Alternatively, laser scanning and structured light scanning are *active* methods; they project a light source onto the surface of an object and a sensor detects and measures the distortions in the projected light caused by the object (Evgenikou and Georgopoulos 2015; Guidi, Beraldin and Atzeni 2004).

### 3.1.1 Structure from Motion

Structure from Motion (SfM) is a photometric imaging technique that uses indirect, diffuse light and 2D image capture which can be accomplished with a standard digital single-lens reflex (DSLR) camera or even with a phone's camera. Images are obtained from all (desired) angles of an object in such a way that the images overlap significantly to ensure accurate point matching. In general, a higher image resolution, a larger set of images, and more importantly, images in which all features are in focus will increase the accuracy of the digital 3D model (Guidi, Beraldin and Atzeni 2004). Once captured, the images can be imported into various software programs ranging from open source free shareware to professional packages like Photoscan from AgiSoft that are designed to generate digital 3D models from the imported 2D images (Barreau, et al. 2014). A unique advantage of SfM is the (relatively) low-cost of the entire the process. No other additional technology is required from a camera, a computer, and

the appropriate software. However, the fidelity of the digital model to the physical object is subject to the quality of the two-dimensional images and the processing software.

### 3.1.2 Laser Scanning

Range data, or laser scanning data acquisition methods largely depend on the material being scanned. Long-range and close-range laser scanning systems are inherently different. Long-range, or time-of-flight, systems send pulses of light and a sensor detects the time the projected beam of light travels to reach a surface and is then deflected back (Remondino 2011). The surface is then mapped by calculating the distance the projected light traveled from the speed of light, a constant and known value. Additionally, long-range, like aerial time-of-flight scanning (LiDAR), is often applied to large-scale projects like capturing an archaeological site. In these systems, the laser source and sensor(s) are not in fixed positions as they are commonly flown overhead. Close-range terrestrial scanners make use of stationary, or fixed position lasers and detectors. This requires the object to change position so that the laser can capture different fields of view (Bernardini, et al. 2002; Jecić and Drvar 2003; Remondino 2011). They are most often chosen for smaller-scale projects, like scanning individual objects. Close-range laser scanning systems project a continuous beam of light onto a surface and calculate the deformations in the projected light based on principles of triangulation as the position of the laser and sensor are constant (Figure 1). This difference between long-range and close

scanning makes the systems involved in processing the acquired data inherently different (Remondino 2011).

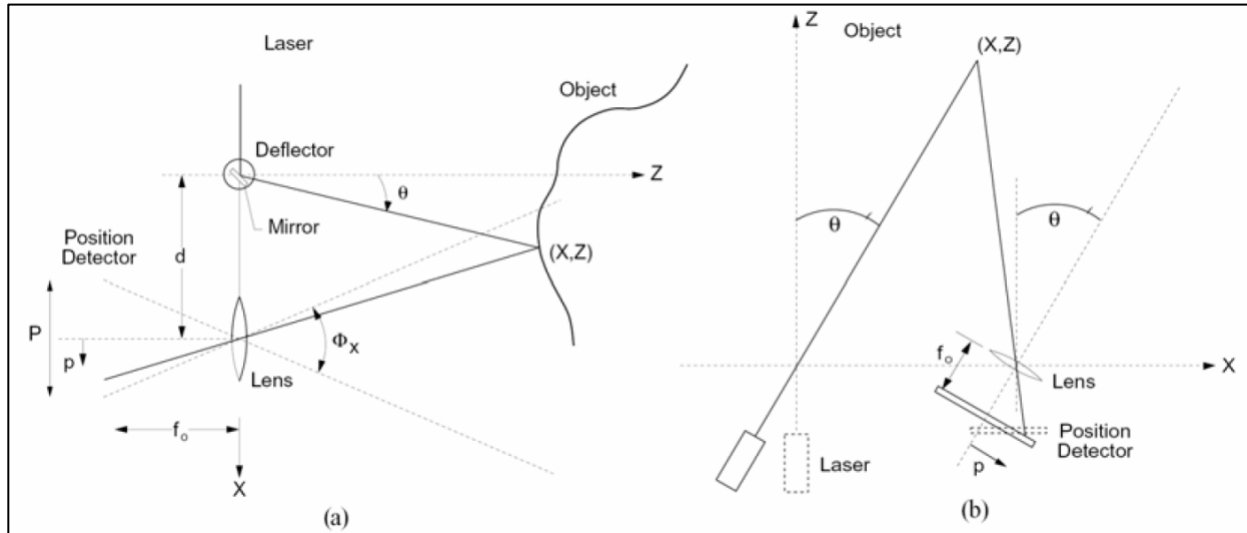

Figure 1: Examples of stationary and mobile laser scanning. A) Schematic of a stationary laser scanner and detector in fixed position and the object on a rotating stage. The laser beam is deflected, hits the object and the reflected light passes through a lens. In this example, the laser and detector are in a fixed position and the object is on a rotating stage. B) Schematic of a mobile system in which the laser and detector move concurrently, thus  $\theta$  is a known and fixed value. For both (a) and (b) triangulation principles can be applied from the known, fixed angles to determine the surface geometry of the target object. Image courtesy of Jecić and Drvar (2003).

### 3.1.3 Structured Light Scanning

Structured light, or “white light”, scanners project patterned light from a visible light source onto the surface of an object and a sensor detects the deformations in the pattern caused by the object (Counts, Averett and Gartski 2016). These projected patterns can either be a fringe light pattern or a coded light pattern; fringe light scanners capture data through several projections of light and need to be kept fixed and still whereas coded light scanners can be handheld and mobile (D. Brown 2012). The position of the light source and sensor are fixed relative to each other, thus, just like triangulation laser scanners, the deformations in the projected light caused by the surface of the object being scanned are triangulated. Advantages of using a Structured Light Scanner are speed and precision. These scanners capture an entire field of view which simultaneously decreases the scanning time and allows for the redundant capture of points

which can increase the fidelity of the resulting 3D model (Soile, et al. 2013). However, they are not as accurate as a quality 3D laser scanner (D. Brown 2012).

### 3.2 The Generation of a 3D Model

Proprietary software inputs the data points collected by data acquisition techniques into three-dimensional space, these points form a dense point cloud. The points are connected to form a digital mesh and surface texture and color information are incorporated to form a CAD (computer-aided design) model (Díaz-Marin, et al. 2015). The meshes created in any 3D data acquisition technique do sometimes require post-processing. Newly acquired meshes and/or complete CAD models often require “cleaning”, that is the removal of unwanted surface information. Inevitably, some of the surface information immediately surrounding round the scanned object are picked up, measured, and included as part of the generated 3D model, resulting in background noise (Evgenikou and Georgopoulos 2015). This noise needs to be cleaned manually using a “trim” option which is standard in most 3D acquisition and modeling software.

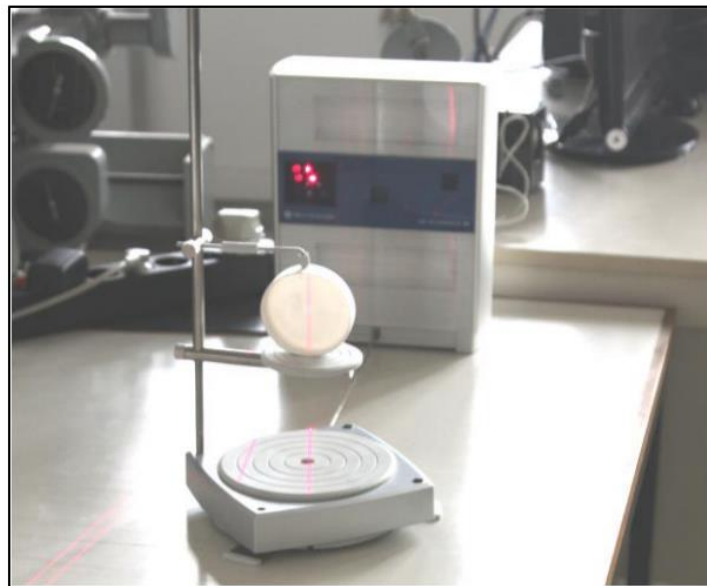

*Figure 2:* The Next Engine Scanner captures the surface geometry of the object held in place by the rotating stage. The scanner inevitably detects and triangulates the portions of the rotating stage which are within the same range as the object. These points are then manually trimmed in the proprietary ScanStudio Software. Image courtesy of Evgenikou and Georgopoulos (2015).

In cases where multiple scans of a single object are performed, the acquired information and generated digital meshes are aligned and merged to create a single 3D model. These steps are often accomplished in software which is proprietary to the technology involved in the data acquisition. Once digital 3D models are “cleaned” than further digital manipulation and modeling can take place. The reconstruction of multiple and separate meshes can be accomplished by a computer algorithm, user-activation (human manipulation), or a hybrid of the two. Algorithms and hybrid approaches are the most commonly cited methods.

### 3.3 3D Printing & Manufacturing

Three-dimensional printing and manufacturing, often referred to as rapid prototyping or digital fabrication, requires a digital file which creates a kind of three-dimensional map where the printers operate along x, y, and z axes. Methods of rapid prototyping are split between subtractive and additive techniques. Subtractive milling has been successfully employed since the 1980s while additive methods are more recent technological developments (Scopigno, Cignoni, et al. 2014). Subtractive milling describes methods in which a digital shape is carved out of a block of material by a computer numerical controlled (CNC) milling tool. While these processes are beneficial in that one machine has the ability to carve from numerous material types, the size of the milling tool has substantial effects on the outcome of the replica, especially if it is a replica of a geometrically complex object (Scopigno, Cignoni, et al. 2014). Additionally, these machines produce significant amounts of waste in the process of carving.

Additive methods of rapid prototyping have seen a surge in application, specifically in the private, or individual, sector as 3D printers are commercially available at a relatively low cost (Neumüller, et al. 2014). Through recent advances in technology, additive processes have expanded on the material possibilities of prints; objects can be printed in metal, paper pulp, ceramic, gypsum, among others; this variability of printing in different materials is, of course, an important consideration for the conservation of cultural heritage objects (Arbace, et al. 2013).



The most common techniques are fused deposition modelling, granular materials binding, and photopolymerization printing (Scopigno, Cignoni, et al. 2014).

3D printing by fused deposition modelling refers to the process of heating a thermoplastic filament and the deposition of the heated plastic in very fine layers. Substantial drawbacks to this method within cultural heritage fields are the textured surface (Figure 3) which require additional, manual labor to smooth the surface and remove the printed scaffolding required to support overhanging elements (Scopigno, Cignoni, et al. 2014; Chua, Chou and Wong 1998). Despite any issues with textured surfaces and the inclusion of scaffolding, FDM printers are among the most affordable at this time. Printing by photopolymerization involves the deposition of liquid resin which is then exposed to an ultraviolet light source. Much like fused deposition modelling this process proceeds layer by layer to create a complete object and requires a printed scaffold to support overhanging areas of the print and is limited in compatible printing materials (Scopigno, Cignoni, et al. 2014).

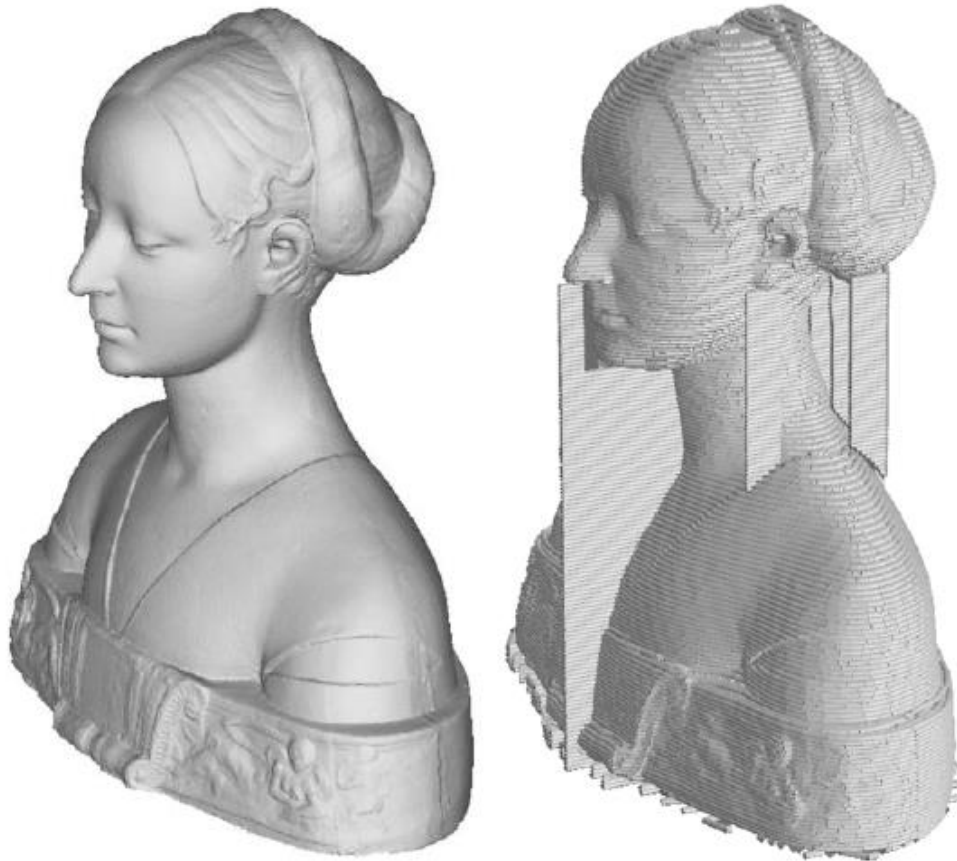

*Figure 3:* The left shows a digital model of an object to be printed, the right shows a digital approximation of the appearance of a print generated by fuse deposition modelling. The printing model shows the scaffolding that will be printed to assist in printing overhanging areas like the chin, nose, ears, and hair. Image courtesy of Scopigno, Cignoni, et al. (2014).

Granular materials binding refers to the additive technique of applying a liquid adhesive via an inkjet printer to a layer of fine powder (i.e. gypsum, chalk, clay) which gradually builds into a complete model. Arbace et al. (2013) state that this is the most popular printing method within cultural heritage fields as it offers a desired aesthetic finish for conservation treatments of materials like ceramic and stone which often use materials like plaster for filling losses. Additionally, dry pigments can be added to the powdered material to make colored prints, a desirable trait in conservation.

#### 4. 3D Digital Technologies in Cultural Heritage Disciplines

There is a myriad of ways in which scholars have used 3D digital files; it has been an active and a constantly evolving field of research for twenty to thirty years (Pintus, et al. 2014). Digital models have been used in efforts to display, document, monitor, study, and reconstruct cultural heritage objects (Guidi, Beraldin and Atzeni 2004). The benefits of 3D digital files are numerous, including but not limited to: enhanced learning through multisensory experiences (Neumüller, et al. 2014; Scopigno, Callieri, et al. 2011; Soile, et al. 2013), remote access to cultural heritage materials (Guidi, Beraldin and Atzeni 2004), virtual restoration (Díaz-Marin, et al. 2015; Fowles, et al. 2003; Geary 2004; Pires, et al. 2006), and the treatment of fragmented objects (Arbace, et al. 2013; Brown, et al. 2012; Collins, et al. 2014; Counts, Averett and Gartski 2016; Sanchez-Belenguer and Vendrell-Vidal 2014).

##### 4.1 Museums and Education

Digital models and 3D printed replicas have the potential to greatly impact museum visits by enhancing the experience of visitors by offering multi-sensory encounters with cultural heritage objects. Used as educational tools, digital models can offer more individually engaging experiences with a wider audience, specifically with the vision impaired, children, and the elderly (Neumüller, et al. 2014). Digitally enhanced exhibition through virtual and/or augmented realities prompt the visitor to engage with the digital material, this subsequently drives the visitor to curate their own personal learning experiences, engaging with the materials they are specifically interested in. 3D printed replicas provide visitors the opportunity to handle accurate

representations of artifacts enhancing the interaction of visitors with displayed objects

(Neumüller, et al. 2014; Scopigno, Cignoni, et al. 2014; Soile, et al. 2013).



*Figure 4:* Vision impaired adults learn about a work of art, specifically a two-dimensional painting, by handling a 3D printed interpretation of the scene. The incorporation of multi-sensory educational materials offers a more inclusive learning experience. Image courtesy of Neumüller, et al. (2014).

Displays of digital three-dimensional models that make use of augmented reality, virtual reality, and/or video game technology can offer context to an artifact or groups of artifacts that would otherwise be displayed with an information placard. The addition of digital technologies in displays can give museum visitors rare insight into excavation processes and important sites and can create virtual exhibitions for those unable to visit museums. These types of immersive 3D visualizations provide a more engaging experience than standard two-dimensional presentations (Bruno, et al. 2010). Figure 5 shows the use of video game technology as a way to engage the public with archaeological materials in a platform that offers context (the archaeological site) to the excavated materials.



*Figure 5:* Here, a monitor and console are depicted in a gallery space. The user is prompted to select between two different archaeological sites. The program has a preset introductory video that then switches to a virtual reality interface. The user can select different objects associated with the site and manipulate them using the console. Here, a lekythos, dish, and table are visible in the environment from which they were excavated. Image courtesy of Bruno, Bruno and De Sensi (2010).

By interacting with the cultural heritage objects, even indirectly via a digital platform, an individual has a more personal experience engaging with the material and will carry the educational information involved with that experience (Neumüller, et al. 2014).

3D printed replicas of art objects can be readily handled by young children and school groups allowing a more active learning experience and the addition of another sensory input (Bruno, et al. 2010; Neumüller, et al. 2014; Soile, et al. 2013). The use of printed replicas also offers vision impaired museum goers the opportunity to better understand the shapes and sizes of fragile or rare objects (Figure 4) (Smithsonian Exhibits 2017). The use of digital models can also extend beyond the museum environs; recently, the Smithsonian has offered free,

downloadable models of artifacts from their collections which are ready for 3D printing (<https://3d.si.edu/explorer/kneeling-winged-monster#downloads>).

## 4.2 Advantages of Digital Models in Archaeology & Art History

3D digital models have already and continue to impact the study of cultural heritage objects and sites. Scopigno, Callieri, et al. (2011) go so far as to imply the future impact of 3D digital technologies as parallel to that of 2D photographic capture in the early twentieth century. Like a digital photograph, once captured, a 3D digital model exists so long as the file remains uncorrupted and can be shared across disciplines, i.e., the same digital file can be shared between an archaeologist, an historian, and a conservator. Each can use the digital model to further their research.

### 4.2.1 Remote Access to Cultural Heritage Sites and Objects

The ability to remotely view, manipulate, compare, and measure cultural heritage sites and objects allows for the continued study of those materials year-round rather than limiting research to excavation seasons and traveling or references to 2D images and drawings. The generation of high fidelity 3D models have allowed scholars to remotely study and obtain precise measurements of objects for their research (Soile, et al. 2013). The ability to precisely measure 3D models allows for the comparison of object typologies and the size of objects and sites. This is particularly beneficial to archaeologists whose work and excavated materials are international. Figure 6 demonstrates how archaeologists can reference excavated trenches at different stages which is not only important as a way to remotely access the material, but to reference earlier stages in the destructive process of excavation.

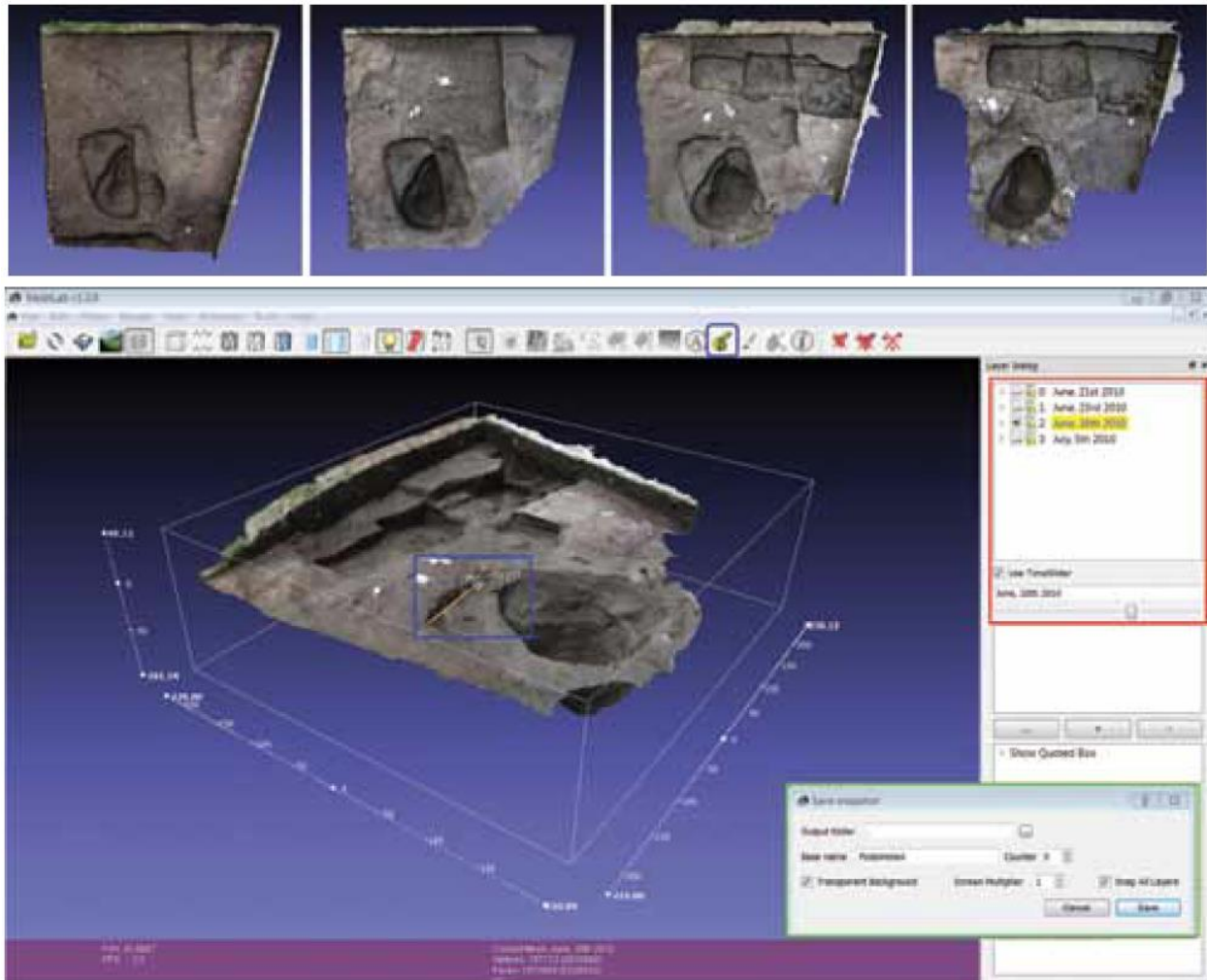

Figure 6: This series of snapshots taken from the MeshLab interface depict an archaeological trench at different stages of excavation. Models such as these offer archaeologists the opportunity to go back and view different stages of the destructive excavation process, input artifact information in its original context, and catalogue this information for future research. Image courtesy of Scopigno, Callieri, et al. (2011).

#### 4.2.2 Digital Restoration as an Art Historical Tool

Digitization of cultural heritage materials have created, and continue to create, innovative ways in which scholars can study materials and make adjustments to enhance visual interpretation based on analytical data. Historical replicas of ancient statues based on trace amounts of color and design are not uncommon (i.e. the Trojan archer) and exist as a means to show the highly decorated surfaces of seemingly plain objects. However, these models are time consuming to create by hand and involve casting large amounts of plaster and precise painting.

Digital restoration is faster, can be easily edited or redone, and offers a different visual perception of the artifact (Figure 7).



*Figure 7: A grave stele c. 380-370 B.C.E. from the Staatliche Antikensammlungen and Glyptothek in Munich, Germany under normal, diffuse light (left), as seen with ultraviolet-induced visible fluorescence (right), and a historical reproduction by Vinzenz Brinkmann and Ulrike Koch-Brinkmann, based on the design visible under UV light. Image courtesy of Reed (2007).*

In a study by Geary (2004), conservators examined the surfaces of a polychrome painted terracotta. The sculpture, a depiction of Saint Christopher in the Victoria & Albert Museum collections, did not look as richly colored and decorated as it would have been upon its creation. The surface was weathered, dirty, and discolored. However, cross-sections of the painted surfaces were taken and examined to determine the pigments used in the original



painting and revealed the remnants of vibrant colors. The conservators were able to digitally apply these colors to the associated areas on a digital 3D model of the sculpture, thus creating a historical rendering informed by the technical analysis of original pigments (Geary 2004). This historical rendering enabled scholars to view the sculpture as it was historically intended.

Similarly, Fowles, et al. (2003) used digital techniques to posit the original surface and decoration elements of a Japanese wooden Buddha rather than removing any paint layers. As is typical with similar polychrome wooden sculptures, there are centuries worth of paint layers and design elements covering the original surface. A digital approach to the recreation of the original surface maintained the religious and spiritual significance of the additional layers.



*Figure 8:* The Buddha on the left is a digital model of the most current decoration. The figure on the right is a digital reproduction of what the original sculpture may have looked like based on comparative materials. Image courtesy of Fowles, et al. (2003).

Studies such as this illustrate how analytical data can be used to enhance digital 3D models and elevate the historical perception of original surfaces. This notion of visual

enhancement could be applied to any artifact as a method of visualizing lost surfaces and decoration without the physical addition of paints.

### 4.3 Digital Technologies in Conservation

3D digital technologies in conservation are relatively new, yet despite their perhaps novice status, the ways in which they have been employed have proved successful. Digital models have offered conservators the ability to digitally restore worn or missing surfaces (Figure 7), to reconstruct fragmented objects (Figure 12Figure 13), and to use 3D printing as a tool for the display and treatment of objects (Figure 14Figure 15Figure 16Figure 17). These projects offer a glimpse into the possible application of digital modelling and 3D printing in the conservation of cultural heritage objects.

#### 4.3.1 Digital Reconstruction of Fragmented Objects

Digital modeling processes vary according to how they will be used; the software and steps in creating virtual reality and interactive experiences is different from the methods necessary in reconstructing fragmented objects. The digital modeling processes for reconstruction described in the surveyed literature can be categorized by their functionality

between fully automated/algorithmic systems, or a human-computer hybrid where a conservator confirms or rejects suggestions created by an algorithm (Collins, et al. 2014).

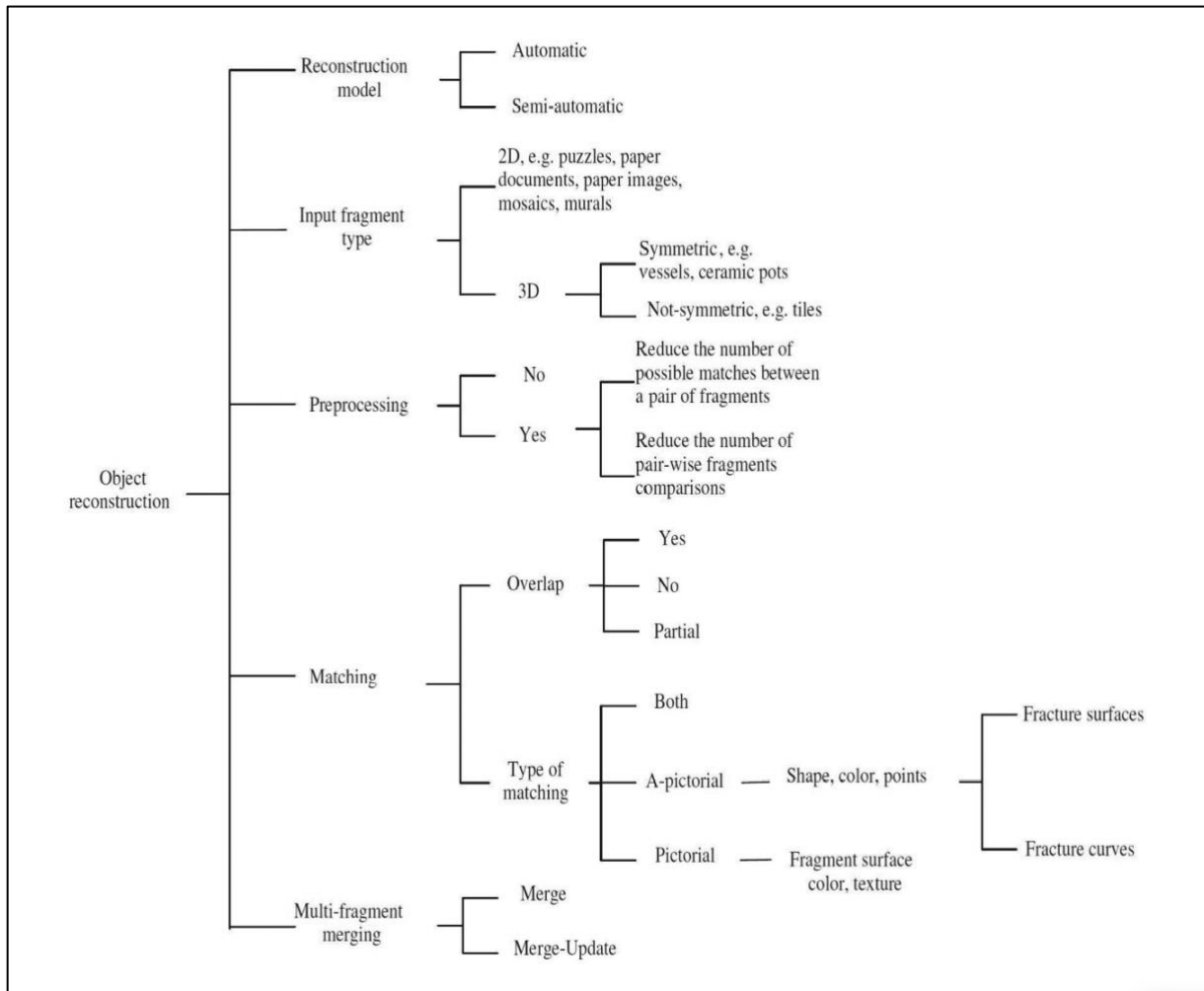
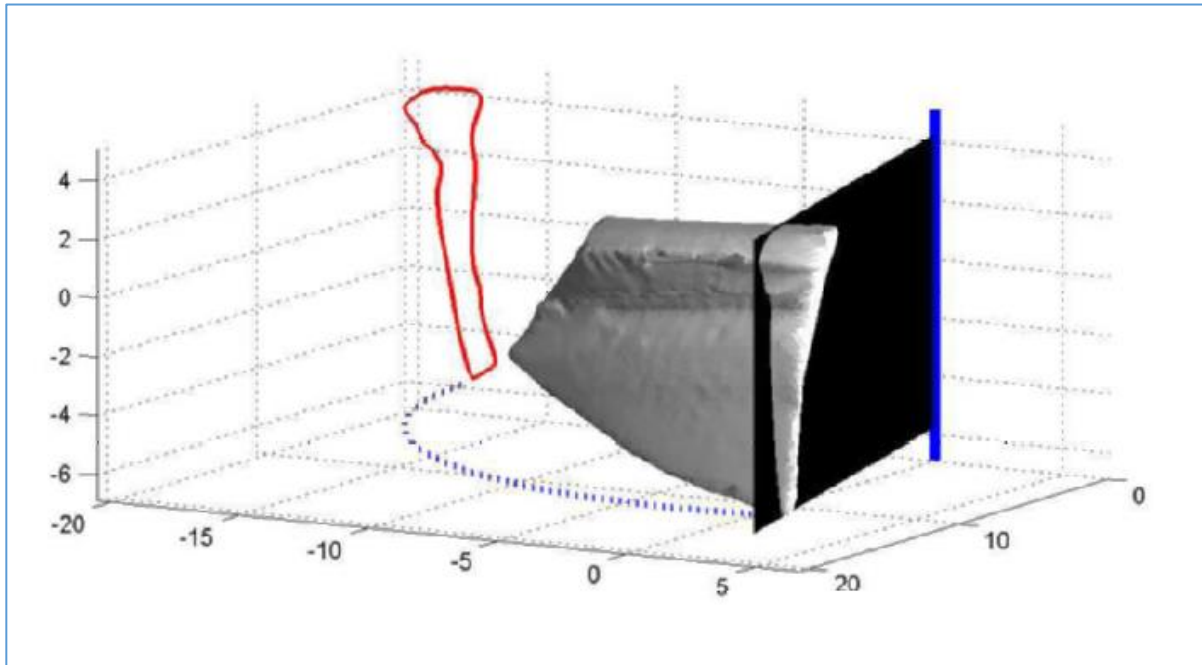

Figure 9: This image reveals the consideration for the creation of an accurate digital model. Each section is broken into smaller subsections, detailing the variables often attributed to characteristics of an object such as the differences between 2D and 3D modeling processes, symmetrical and asymmetrical objects, and matching protocol. Image courtesy of Tsamoura, Nikolaidis and Pitas (2012).

### Effects of Geometry on Reconstruction

For the reconstruction of three-dimensional fragmented materials, there are several important factors to consider: Is the object axially symmetrical (i.e. vessel/pot) or asymmetrical (i.e. figural); are there substantial gaps or losses; and how eroded are the break edges? Matching algorithms are written to account for the presence of axial symmetry or to analyze the surface geometry of fragments from asymmetrical objects. For fragments of axially symmetrical

shape, the curve can be used as an identifying location estimator (Kampel and Sablatnig 2003; Willis and Cooper 2004; Pires, et al. 2006).



*Figure 10:* Digital reconstruction of axially symmetrical objects makes use of the regular and predictable geometry of the piece. This process makes use of similar principle to technical illustration which uses a diameter measured from intact fragments of vessel rims. Image courtesy of Kampel and Sablatnig (2003).

Alignment methods based on axial symmetry and the inherent geometrical assumptions therein cannot be applied to asymmetrical objects. Automated methods for asymmetrical objects must analyze the geometry and topography of all break edges, interior and exterior (Huang, et al. 2006; Willis and Cooper 2008). Pieces containing an exterior surface will have a carved or manufactured surface edge that can facilitate its placement within the context of the object as a whole. Interior fragments have no discernible characteristics; all sides of an interior fragment are broken edges (Huang, et al. 2006). It is important to note that asymmetrical objects can be hollow, partially hollow, or solid and there are substantial differences in the geometry of hollow and solid sculpture. Fragments associated with hollow asymmetrical objects may retain a largely unmodified original surface (the interior) even if exterior surface features are lost. In contrast,

fragments from solid asymmetrical objects will likely include both exterior and interior surface fragments where the interior surface fragments have no artificial or manufactured edge.

### Automated Reconstruction

Algorithms and computer code based around geometric principles have been specifically written and applied to find matches between fragments by examining surface features and decoration, by measuring the edge curves and geometry of fractures, and by extracting the surface geometry of all faces of three-dimensional fragments. Automatic, that is, unassisted and computer-driven, reconstruction is particularly difficult as each fragment has a random number of break surfaces, thus a very large number of possible matches to explore (Huang, et al. 2006). Therefore, the goal of most automated systems is to ascertain some matches within a larger puzzle, reducing the man-hours of the conservator or archaeologist (Willis and Cooper 2008). To reduce the complexity of the problem, automated matching systems consider global and local registrations of fragments: a fragment's global registration accounts for the surface features and the geometry of curves, its local registration looks more specifically at the geometry of break edges or singular features to locate possible matches. Thus, an effective automated matching program for a fragmented ceramic vessel would consider the global registration and geometry of the curve of the fragments, and the local geometry of the break edges.

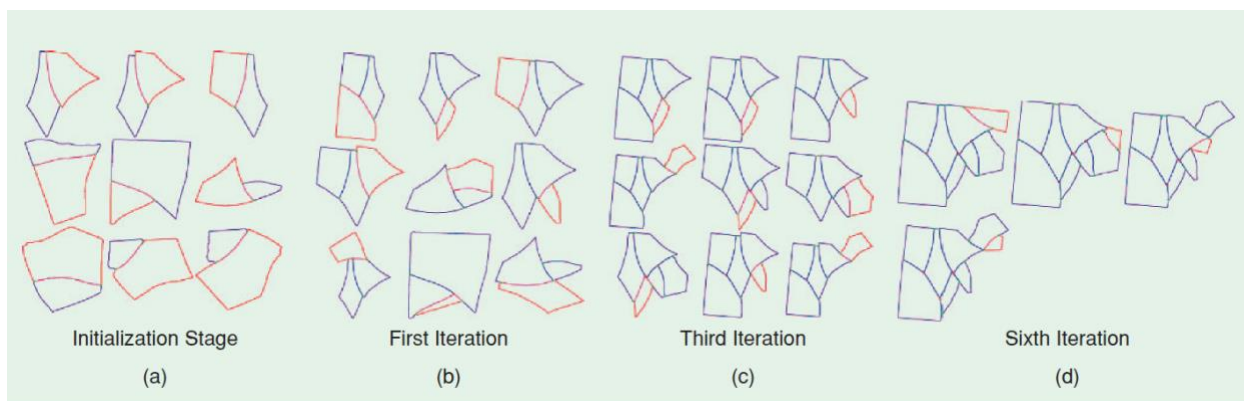

*Figure 11:* Fragment pairs of a ceramic tile are used to illustrate the different starting points in an automated reconstruction based on the global registration of the fragments. Image courtesy of Willis and Cooper (2008).

Successful matching algorithms account for the size of each fragment and the surface geometry of broken and unbroken edges to then assign a location relative to other analyzed fragments. However, archaeological fragments present a set of unique variables in that edges of fragments are often altered through breakage and erosion during burial. This alone, presents a significant issue in the application of algorithmic matching as the absence of neighboring points prevents a precise alignment, especially if there are no discerning surface features or decoration.

### *Semi-Automated (User- Computer Hybrid) Reconstruction*

Successful digital reconstruction projects discuss the combined efforts of computer scientists who have written specific matching algorithms and conservators whose expertise is applied to the computer-generated matching suggestions. These hybrid computer algorithm/user activation methods allow conservators to ultimately make decisions on the matches generated by the computer, making use of the conservator's training and expertise (Arbace, et al. 2013; Collins, et al. 2014). Project approaches that combine the piece-matching capabilities of computer algorithms and the expertise of trained conservators have shown great promise (Adan, et al. 2012; Arbace, et al. 2013; Collins, et al. 2014; Brown, et al. 2012; Kampel and Sablatnig 2003; Pires, et al. 2006; Willis and Cooper 2004). These projects utilize computer algorithms to suggest matches between fragments and a user either confirms or rejects the proposed match (Figure 12Figure 13). Kampel and Sablatnig (2003), Willis and Cooper (2004), and Pires et. Al (2006) describe human-computer hybrid methodologies that specifically make use of the axial symmetry of ceramic vessels.

Computer algorithmic approaches to reconstruction automate the fragment matching processes which is especially useful for large objects broken into hundreds of pieces. These computer programs make use of geometric theorems to match curves in three-dimensional space (Pintus, et al. 2014; Willis and Cooper 2008). An algorithm written with the purpose of

reassembling fragmented artifacts from 3D digital models of the separate fragments was developed in an effort to maximize computing efficiency and minimize human input (Huang, et al. 2006). Arbace, et al. (2013), Collins, et al. (2014), and Brown, et al. (2012) detail their use of semi-automated systems to digitally recompose fragmented materials. A system analyzes scanned materials and suggests matches based on the geometry and surface features of the fragments. A user must verify the matches suggested by the computer, utilizing the expertise and experience of the conservator. In their efforts to find joins amongst thousands of Roman fresco fragments, Brown, et al. (2012) developed a program that detected 6103 possible matches and ended up with seventeen confirmed matches. Though the confirmed matches comprise less than one percent of the proposed matches, they report that it took the researchers only a few hours to go through all of the joins proposed by the computer compared to the days it would likely have taken to do so by hand.

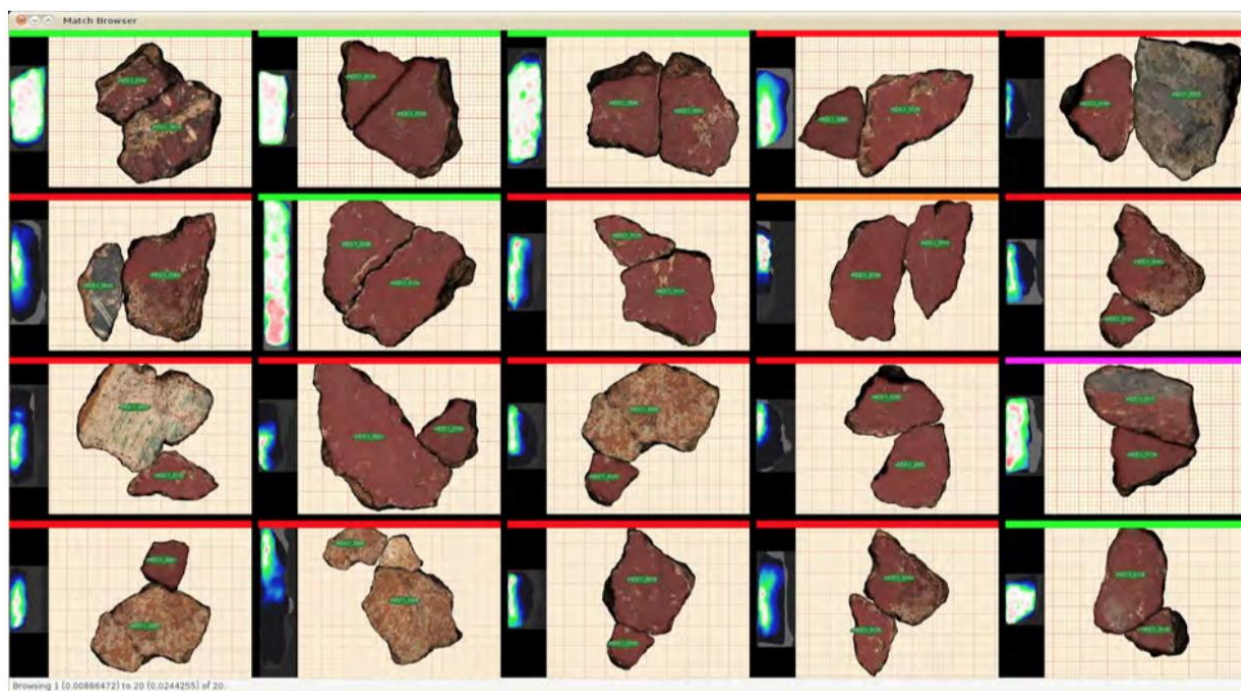

*Figure 12:* Results from a match browsing application. The program generates potential matches from the imported scans which are displayed as thumbnails in batches of twenty. A user then confirms or rejects the generated matches which are marked green for confirmed matches, orange for possible matches, and red for rejected matches. All conflicting matches are automatically marked purple. To the left of each possible match is a heat map colored cross section of the join, true matches have a mostly white cross section due to the tightness or accuracy of the proposed join. Image courtesy of Brown, et al. 2012.

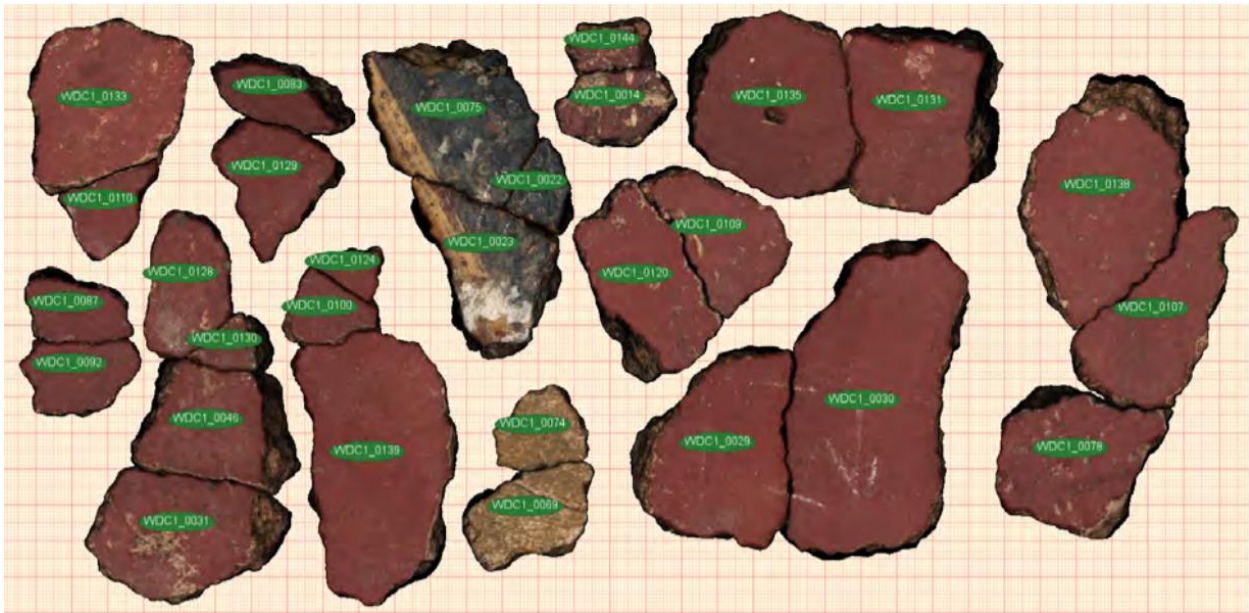

Figure 13: Brown, et al. uses their scanning software to find seventeen matches among twenty-nine fragments. Image courtesy of Brown, et al. 2012.

In a ceramic reconstruction project undertaken in 2013, conservators applied 3D modeling to create an innovative approach to the reconstruction and conservation treatment of a fragmented terracotta statue which was damaged by an earthquake in 2009 (Arbace, et al. 2013). Because of the substantial losses and surface irregularity of adjoining fragments, a computer automated matching approach could not efficiently match the twenty four fragments. They employed a system of imaging matched pairs held in place by the conservator which offered enough geometric data to digitally align the fragments.

#### 4.3.2 3D Printing to Assist Display and Treatment

Museum curatorial and exhibition staff have been able to create custom mounts and storage for collection materials using digital modeling and 3D printing; digitally sculpting a support from a 3D model allows the user to follow the specific surface geometry of an object without handling the object itself. In a project undertaken by the Smithsonian exhibit staff, a digital model of a fragile object was obtained by laser scanning, a custom mount was created from the 3D model, and both the mount components and a replica of the object were printed. The mount pieces



were put together and any necessary reshaping and adjustments were performed by fitting the mount against the object replica. This allowed the cultural object to be adequately supported while on display but left relatively unhandled during the production of its custom support (Smithsonian Exhibits 2017).

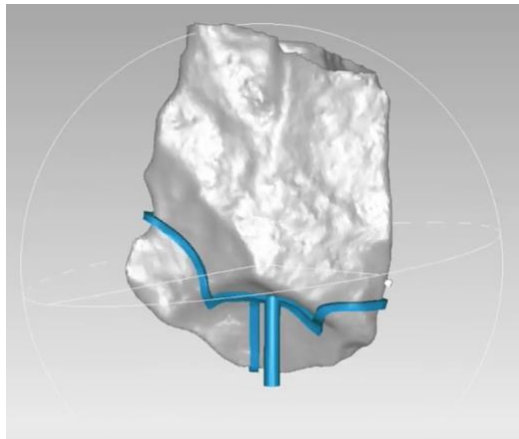

*Figure 14:* The support (in blue) was created in a CAD software onto the digital model of the object. Image captured from and courtesy of Smithsonian Exhibits.



*Figure 15:* The modeled support was printed and then used to facilitate the display of the object. Image captured from and courtesy of Smithsonian Exhibits.

3D modeling and printing to reconstruct and treat objects has been successfully employed by Arbace, et al. (2013) and Barreau, et al. (2014); each project details their use of creating custom supports by 3D computer modeling and 3D printing. The green, pink and purple details in Figure 16 show the digitally modeled areas which were produced by the granular

materials binding method of rapid prototyping. These printed supports were customized to support the large fragmented terracotta sculpture (Arbace, et al. 2013).

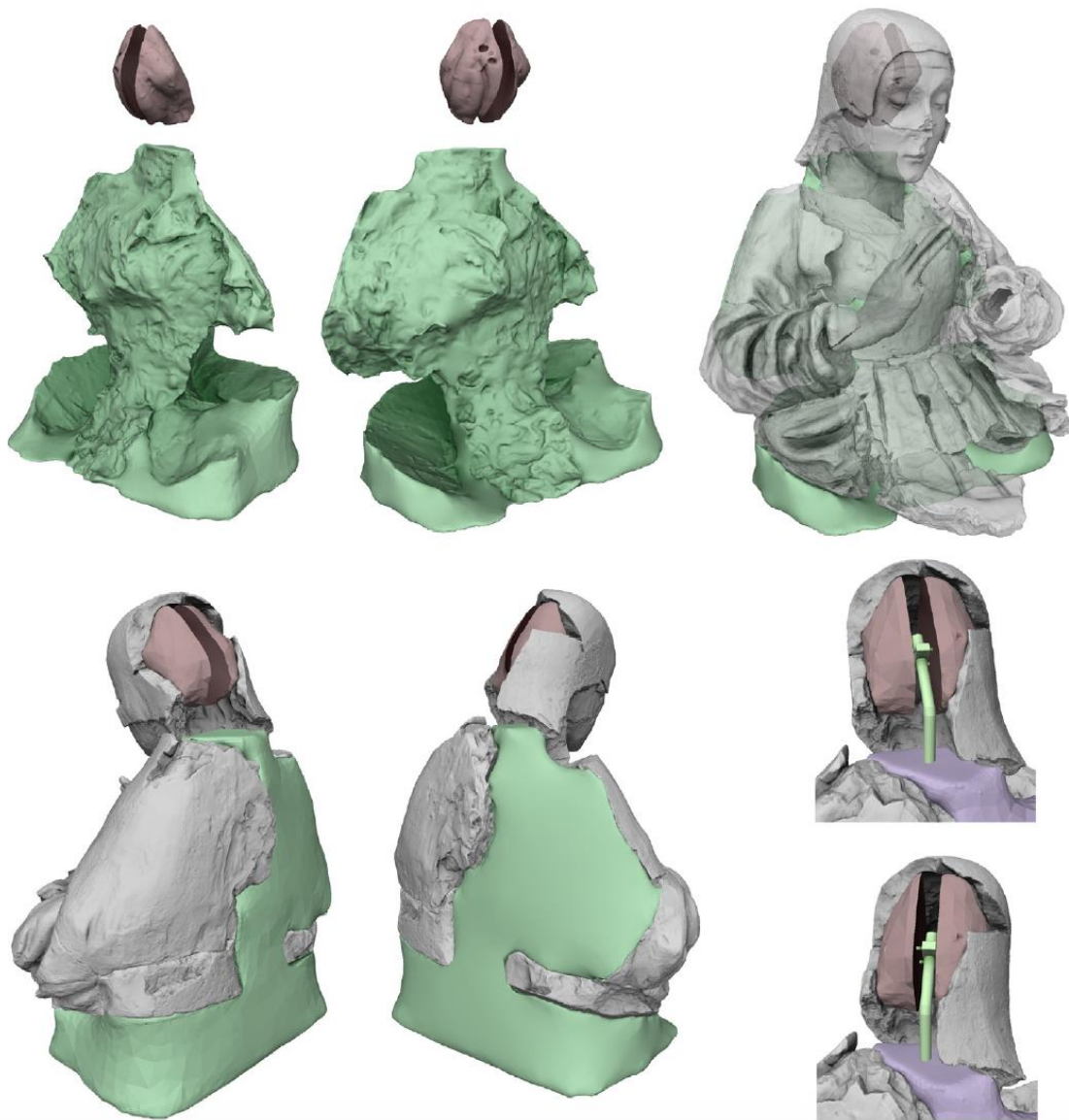

*Figure 16:* This series of images details the 3D modelled areas (in color) which were produced by rapid prototyping to provide the necessary structural support for the reconstruction and treatment of the fragmented terracotta. Image courtesy of Arbace, et al. (2013).

Barreau, et al. (2014) created a custom support for an archaeological ceramic with significant losses (Figure 17). The support was digitalled modelled in MeshLab by extrapolating an approximate volume and shape from the existing fragments. It was printed in an acrylonitrile butadiene styrene plastic with a fused deposition modelling 3D printer and was printed in two

parts as the size limitations of the printer prevented printing the model in its entirety (Barreau, et al. 2014).



*Figure 17:* The images in the top row show the modelled support and fragments in digital space. The support (bottom left) is printed in an ABS plastic and the fragments fit within the indented spaces (bottom right). Image courtesy of Barreau, et al. (2014).

## 5. Materials, Methods, & Technologies

### Materials

Two identical, modern low-fired ceramic pots were purchased for the experiment. The first was left intact as an extra in case of substantial breakage and for comparison and future experimentation (Figure 18). The second pot was broken by lining it with a polyethylene bag, packing the bag full of glass beads, and lightly tapping the ceramic with a hammer. This process resulted in eight fragments: five rim sherds, two base sherds, and one body sherd. The body sherd was left out of the digital reconstruction to represent a loss (Figure 19). The ceramic pot is approximately 9.3 centimeters tall with a 12-centimeter diameter. It should be noted that the

two base sherds broke in several places while in transit during the experimental process. They were adhered together for the purposes of this experiment and can be seen in Figure 19.



*Figure 18:* The ceramic vessel acquired for the purposes of this experiment prior to breakage.



*Figure 19:* The ceramic pot was broken into eight sherds. The circled body sherd was left out of the digital reconstruction to represent a loss.

## Methods and Technologies

The scanning technologies used to obtain 3D scans and the 3D printer for this project were available through the Digital Lab in the Cotsen Institute of Archaeology and the Digital Humanities Lab at the University of California Los Angeles. The chosen 3D modeling programs are available as free internet downloads. User-activated digital reconstruction from generated digital models of each sherd and 3D printing from that digital modeling process were used for the subsequent physical reconstruction and conservation treatment of the ceramic vessel.

### 5.1 3D Data Acquisition

Digital models of the ceramic sherds were generated first using a NextEngine™ laser scanner, a table top triangulation scanner, in the Digital Lab at the Cotsen Institute of Archaeology and an Artec Space Spider, a handheld structured light scanner at the Digital Humanities Lab at the University of California at Los Angeles. The first technique, laser scanning, used a laser line to scan the object while the second, structured light scanning, relied on the projection of patterned and coded light.

#### 5.1.1 3D Laser Scanning

The eight sherds were scanned three times with a table-top Next Engine 3D triangulation scanner to obtain topographic and texture information on all sides. This scanner projects a vertical laser line onto the surface of the object which moves on a rotating stage (Figure 2 & Figure 20). The detector picks up the reflected light and the geometry of the surface is determined from triangulation principles. The position of the laser and the camera are fixed, and the distance of the object to the laser is a measured and known value, the laser, sensor, and object form a triangle allowing for the accurate triangulation of collected points and the generation of a digital 3D model, detailed in Figure 1 (a). The sherds were placed at a distance of about eleven inches from the scanner and held in place on the rotating stage. The longest scan for each sherd was performed on the sherd orientation in which the most surface area

information would be collected; the rotating table was programmed to spin 360 degrees and the laser scanner captured information throughout the full rotation (Figure 20).

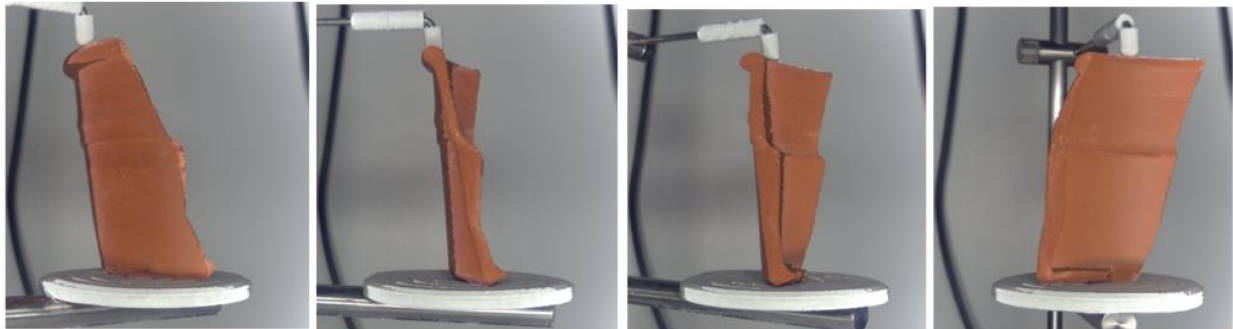

Figure 20: These images were captured during a scan with the Next Engine\* Laser Scanner. A digital camera captures 2D images of the object being scanned and uses those photographs to generate the color and surface texture for the 3D model. Here a rim/body sherd is held in place by the rotating stage moving 360 degrees to capture the most surface area possible. Later, scans of the rim and base surfaces, which are concealed due to the position and stage, were captured and aligned through user-activated point matching in ScanStudio (a proprietary software for the scanner).

The other two scans were performed over a 180 degrees rotation to capture data of the ‘top’ and ‘bottom’ or edges of the sherd which were not accessible in the first scan. These three corresponding scans per sherd were individually trimmed of excess “noise” as the rotating stage and additional supports were often captured by the laser scanner. The three scans were then aligned using a point-match system wherein a minimum of three points were chosen on the most comprehensive scan and the same points were chosen on the scans of the ‘top’ and ‘bottom’ of the sherd. The ScanStudio software *Align* function merged the scans based on the position of the user-set points. Once the three scans were merged, final trimming and finishing were performed. The 3D models were then exported as Object (\*.obj) files.

### 5.1.2 Structured Light Scanning

For this scanning methods, the handheld Space Spider scanner from Artec was used to collect 3D data. The scanner has six blue LED light sources and five camera detectors which capture surface information at eight frames per second, the user sees the generation of the 3D model in real time which helps ensure the handheld device is maintaining the optimum distance from the object.



Figure 21: The Artec Space Spider handheld structured light scanner. Image courtesy of product website: <https://www.artec3d.com/portable-3d-scanners>

The collected data is input into a proprietary software which generates a live model. The program has an automated alignment function to merge multiple “scans” of the same object from different angles. However, the automated function is not one hundred percent reliable unless there are very specific surface features and textures. This often requires the user to align multiple scans. Generating the 3D models for all eight of the sherds took approximately three hours which gives the Artec Space Spider a great advantage over the Next Engine Scanner regarding speed.



### 5.3 Digital Reconstruction

MeshLab and Blender were chosen to digitally reconstruct the fragmented and incomplete ceramic. They are both open source and are available as free internet downloads. Most of MeshLab and Blender's functions require an in depth understanding of computer modeling jargon that a new user without a background in modeling software would find overwhelming. Gaining an understanding of and achieving a certain comfort level using these programs required substantial blocks of time dedicated to watching video tutorials, trial and error, and consultation with individuals more experienced with each program.

### 5.4 3D Printing

The digital file created from the generation of new mesh to fill the loss was saved as an \*.stl file in order to be compatible with a LulzBot Taz 6 3D printer. A polylactic acid (PLA) biodegradable thermoplastic was chosen for its affordability and low percent shrinkage; in order to create an accurate fill for the ceramic, minimal shrinkage was required, and different filaments shrink as they cure to varying extents.



Figure 22: The LulzBot Taz 6 fused deposition 3D printer. Image courtesy of product website: <https://www.lulzbot.com/store/printers/lulzbot-taz-6#&qid=2&pid=1>

## 6. Results

The ceramic sherds were each scanned successfully, making use of two different data acquisition techniques. The digital reconstruction of the fragments was accomplished through a completely user-driven approach and tested in two different open-source sharewares. New mesh was modeled in Blender that occupied the void within the ceramic body. The new modeled mesh was printed in polylactic acid (PLA), a biodegradable thermoplastic. This 3D print was cast in a two-part silicon rubber so that the shape could be replicated in a more conservation-friendly material. The new fill can be used in the conservation treatment of the ceramic.

### 6.1 Data Acquisition

Scanning with the Next Engine Scanner took a very long time. Each 360° scan took approximately eighty-two minutes while the 180° scans took about thirty-five minutes. This amounted to a minimum of one hundred and fifty-two minutes or two and a half hours of scanning per sherd.

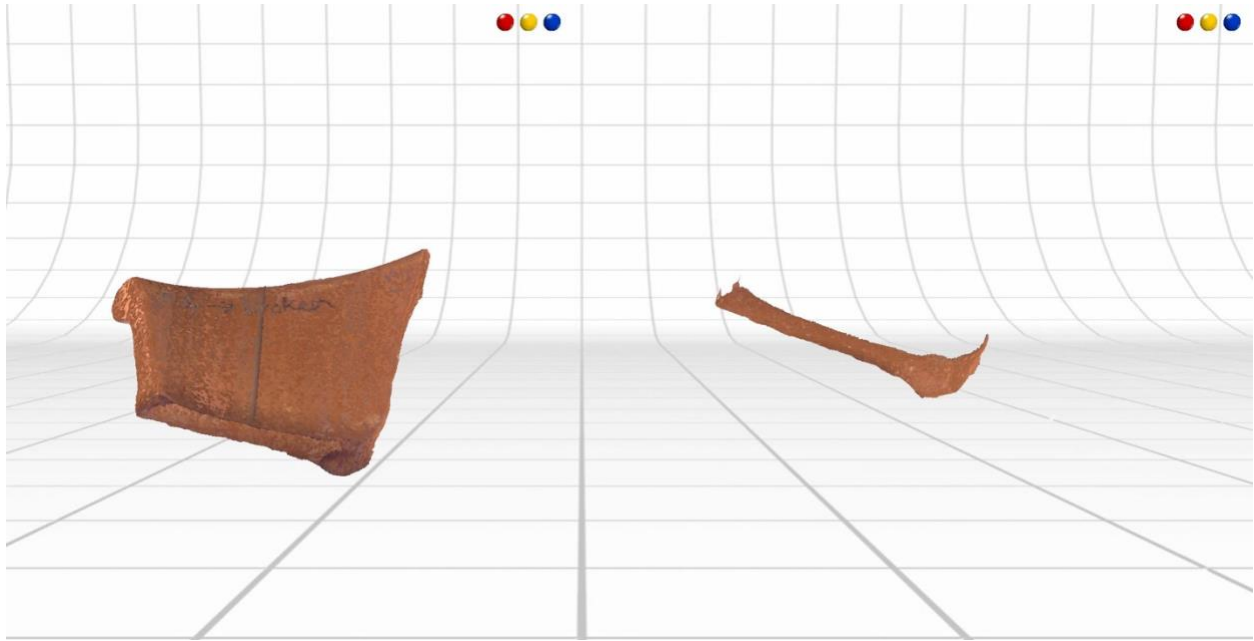

Figure 23: ScanStudio™ Software showing two scans prior to joining. The scan on the left shows the 360-degree scan of the sherd, while the scan on the right shows one of the two corresponding 180-degree scans which captured the bottom edge of the sherd.

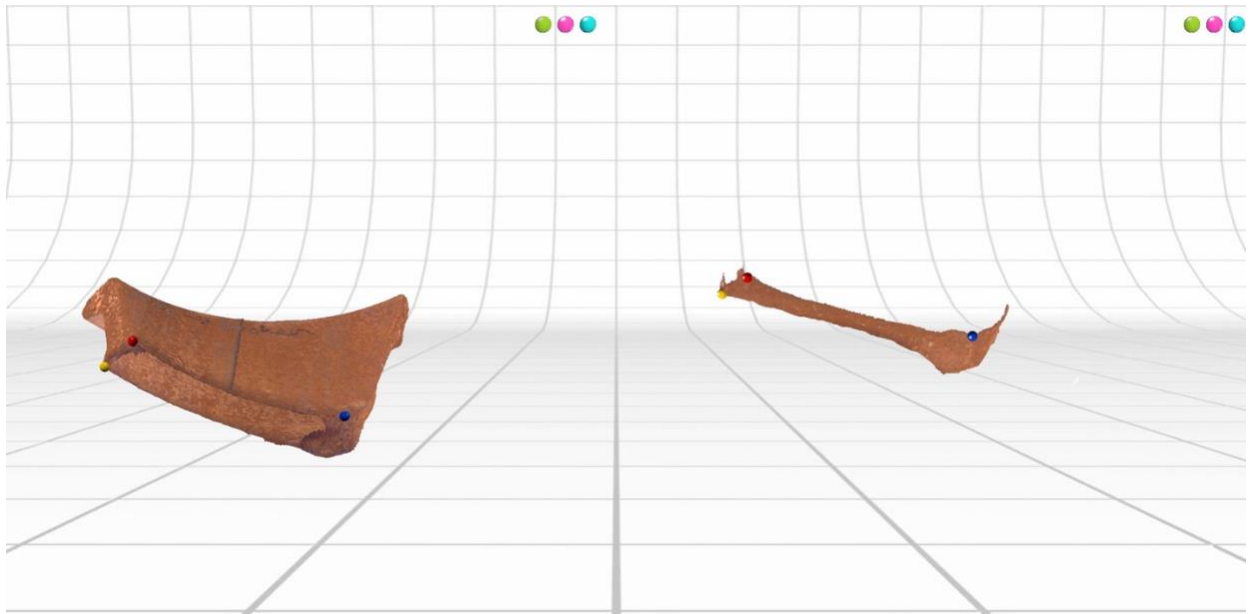

Figure 24: These images, captured from the ScanStudio Software, show the more comprehensive scan of the sherd on the left, and a scan done to capture an edge geometry on the right. The first image was captured prior to setting the color markers. The second image shows the yellow, red, and blue dots which indicate areas selected by the user and will align the scans according to the corresponding color points. Three points of correspondence are required for the software to align the scans though more points can be chosen which can be seen in the second image where the green, pink, and cyan points are present.

Once the three scans per sherd were complete, the point clouds needed to be cleaned and merged to create a complete 3D model. This was done using the *Trim* and *Align* functions in ScanStudio, a proprietary software available with the NextEngine laser scanner. The *Trim* function was used to eliminate the parts of the rotating stand that were picked up by the scanner and the *Align* function was used to merge the three corresponding scans into a single mesh. However, a test print showed that, on occasion, the complimentary smaller scans registered as interior space, not exterior surface, which resulted in several holes in the print.

The three-dimensional \*.obj files exported from ScanStudio were all extremely large files, ranging from 61.8 to 665.7 megabytes (MB) (Table 1). Each file was opened in MeshLab where they were individually decimated using the *Quadric Edge Collapse Decimation (with texture)* function under the “Remeshing, Simplification and Reconstruction” title found in the “Filters” toolbar tab. Each file was decimated by a factor of .25 – .50 to decrease file size; this was a necessary step so that each sherd could be easily manipulated in digital space. The decimated files were then saved and exported as separate \*.obj files from the original. This allowed the original files and the decimated files to be saved separately in case any problems occurred with either. However, the files could not be decimated to an easily usable size without compromising the accuracy of the digital models.

The models generated by the Artec Space Spider are substantially smaller files; they ranged from 2.5 to 33.7 MB (Table 1). They did not require decimation prior to alignment. They were easily imported into MeshLab and Blender whereas the NextEngine models required a few minutes to load. Additionally, once in the software, there was no lag time for the user manipulation of the Artec Space Spider models in either of the software programs.











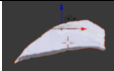



NextEngine Laser Scanner					Artec Space Spider			
3D model	Exported File Size (megabytes MB)	Decimated File size (megabytes MB)	Decimated Mesh Vertices	Decimated Mesh Faces	3D Model	File Size	Mesh Vertices	Mesh Faces
	61.8	24.8	113,737	212,870		2.5	20,674	41,349
	315.5	126.7	548,769	1,027,473		13.2	99,823	199,646
	539.7	212.4	897,901	1,735,237		23.7	171,315	342,626
	665.7	262.2	1,096,574	2,131,278		30.1	215,632	431,260
	242	97	415,292	799,945		8.8	66,830	133,656
	96.8	23.5	109,166	200,306		9.2	69,947	139,890
	835	333.8	1,385,240	2,670,764		33.7	240,184	480,364
	629.4	248.5	1,048,763	2,015,766		33.4	237,884	475,764

Table 1: The table below highlights the differences between the two data acquisitions methods used in this project. The 3D models generated by the Next Engine Laser Scanner were substantially larger files, even after decimation. This made the manipulation of the Next Engine models much more cumbersome to manipulate in the modeling software programs. Alternatively, the 3D models generated by the Artec Space Spider were much smaller, but still maintained a high resolution capturing the geometry of the broken edges.

## 6.2 Digital Reconstruction

Reconstruction of the ceramic sherds was tested in MeshLab and Blender. The first attempts at reconstruction were performed using the models generated by the NextEngine laser scanner in MeshLab. However, the files generated from the laser scanner were too large to be manageable on a personal laptop computer and decimation to reduce the file sizes to a workable level resulted in an over-simplification of the break edges and loss of break edge surface geometry. Digital models generated by the Artec Space Spider were more manageable files. Opening these files in MeshLab and Blender was a much quicker process and they did not require the additional steps of decimation.

### 6.2.1 Reassembling Fragments in MeshLab

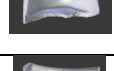
Reconstruction in MeshLab did not result in a complete model of the ceramic vessel, and subsequently was not able to offer the opportunity of creating a new mesh for loss compensation. The base sherds were successfully joined together and most of the rim and body sherds were successfully joined, though not to the base sherds; this process created two large files, one which required further decimation as the file size was 1.82 gigabytes. Until this decimation was completed, the file was too large and caused issues trying to select matching points between the model of the body and the model of the base. To begin, two decimated \*.obj files of adjoining sherds were imported into MeshLab. Using *Align*, one sherd was glued in place and the other was selected for point-based gluing. This selection opens a pop-up window where the two meshes may be manipulated individually and the user is prompted to select four corresponding points on each sherd. After successfully selecting four corresponding points, the user may then apply *Align*. The program will align the sherds according to the chosen points in the original MeshLab window. Once aligned, the two meshes should be selected by right clicking the files names visible in the box on the right and selecting the *Flatten Visible Layers* option. This function merges the two separate files into a single mesh (at which point, the

texture is lost; however, for this project the loss of texture is not important). The aligned sherds can then be manipulated and saved as a single mesh.

Upon joining four body and rim fragments into a single mesh and the two base sherds into a single mesh the file size drastically increased. At this point, these two meshes have not been successfully merged, nor does it appear feasible. Whether the file size is too large or there is another problem is unclear, however the user seems to reach a stalemate after four or five sherds are merged.

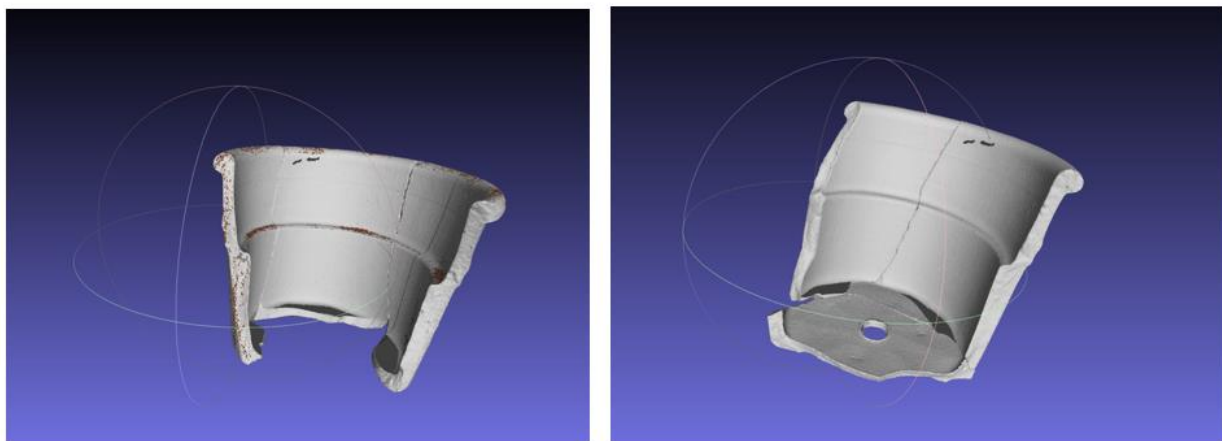

*Figure 25:* The screenshots above show three successfully merged sherds on the left and four merged sherds on the right. This was accomplished using the user-activated piece matching systems in MeshLab.

### 6.2.2 Reassembling Fragments in Blender

Blender allows for the increased and individual control of each sherd in three-dimensional space. The \*.obj files obtained from the Artec Space Spider were imported into Blender one at a time. At the top right of the program window there is a box showing all of the file names that have been imported. Each sherd can be manipulated independently along an x, y, and z axis, this process is substantially easier with a computer mouse. To move each sherd, the user should be operating in “Object” mode, a setting that can be chosen at the bottom of the window. Once two sherds are aligned, the meshes can be merged by selecting the two corresponding files from the list at the top right corner and applying a Boolean Modifier. This

appears as a small wrench  icon, which prompts a drop-down window with the option to “Add Modifier”, sequentially select “Generate > Boolean > Operation > Union” from the drop-down menus that appear. This joins the two separate models into a single mesh. These operations were repeated until the entire ceramic was aligned and merged. However, it was found that merging the individual models of sherds was a somewhat unnecessary step; once aligned in space, the fragments will not move unless further manipulated by the user.



*Figure 26: The digital reassembly of the ceramic sherds and the loss within the ceramic body.*

To generate a mesh that occupied the loss within the ceramic body, a plane was made by selecting “Plane” under the “Creation” tab on the left toolbar. A single point was left to begin and “Snapping” was selected by clicking the magnet icon at the bottom toolbar along with



“Faces”, this ensures the vertex of the new plane will *snap* to the nearest existing object, the existing object mesh. Points were selected along the break edges to create the custom plane. First, points along the break edges’ exterior surfaces were selected. This created a custom loop that conformed to the break edge. A point from the exterior loop was duplicated and moved to the interior edge with the keyboard shortcut “Shift + D” which was used as a starting point to create a loop that conformed to the interior break edges. It is important that there are the same number of selected points on the exterior and interior loops; this number is visible at the top of the screen. “Bridge” was selected from the “LoopTools” section in the left toolbar which bridged the space along the fracture surfaces between the loops, effectively generating the boundaries of a new cylinder. The edges of the new mesh will be more detailed and accurate with more selected points along each loop. The exterior and interior loops were then individually selected and extruded.



*Figure 27:* The new cylinder is extruded on the interior and exterior (visible here on the exterior). From this point, the mesh for the “new sherd” is cut out by overlapping an existing sherd and applying a Boolean Modifier.

From this point, one of the larger sherds which occupies space that is axially symmetrical to the loss was duplicated (Shift + D). A pivot point was selected as close to the center as possible. The duplicated sherd was rotated using the selected pivot point so that it overlapped the new extruded cylinder. ‘Normals’ were reset with the keyboard shortcut “Ctrl + N”. The ‘3D Print Toolbox’ was selected under ‘User Settings’; ‘Distorted’ was then selected from the 3D Print tab on the left-hand toolbar; this breaks the mesh into triangles instead of squares so there are no flat faces. A Boolean modifier is applied by selecting Add Modifier > Boolean > Intersect. This left a new mesh that fit within the loss of the ceramic body of the digital reconstruction. There are slight differences between the created mesh (Figure 28) and

the mesh acquired from scanning the existing ceramic sherd (Figure 29). These differences could be attributed to an error in the data acquisition, modeling, or reconstructing phases of the experimental process. Additionally, there may be some variability in the accuracy of the print depending on the material the digital file is printed in.

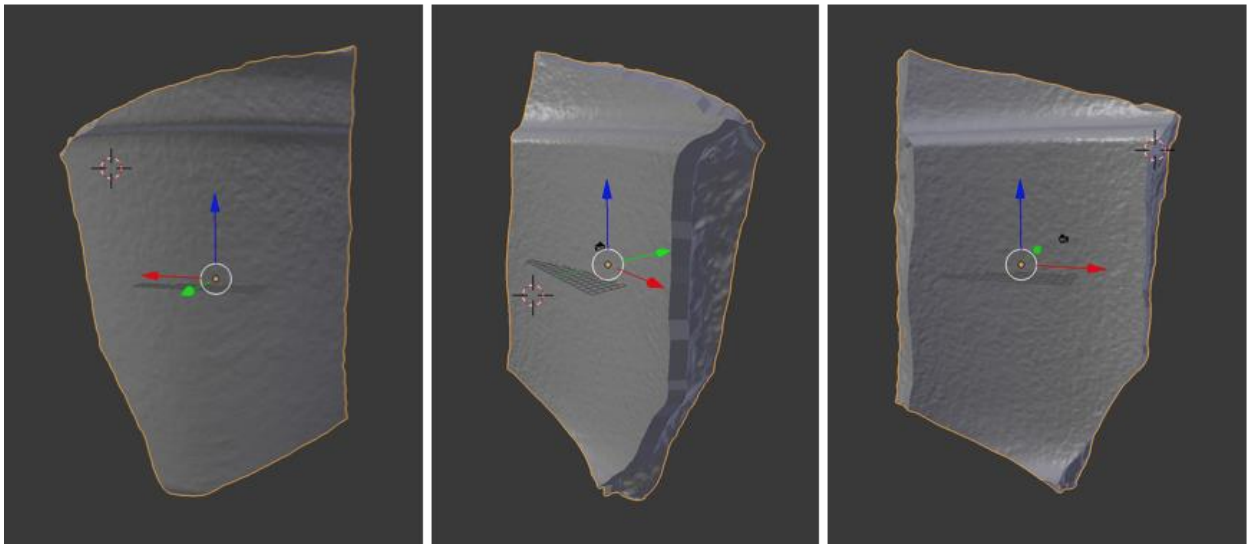

Figure 28: The new mesh is seen here from three different viewpoints. It has been isolated from the reconstructed ceramic and saved as an \*.stl file in order to be printed.

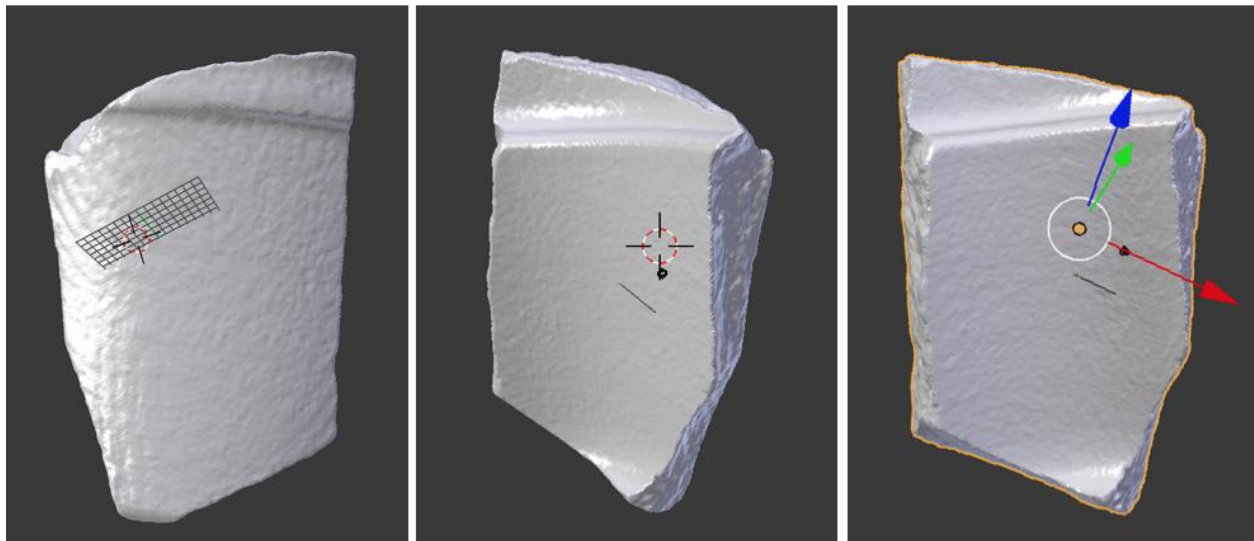

Figure 29: The scanned sherd compared to the modelled sherd (Figure 28) from three different angles. There are some minor differences in geometry of the edges, but the overall shape, and incorporation of detail from the original materials in the digitally modelled sherd is clear.

### 6.3 3D Printing

The new mesh was printed in polylactic acid (PLA) a biodegradable thermoplastic with a LulzBot Taz 6 printer. The printer is a fused deposition modelling 3D printer; it heats the filament and deposits it in fine layers. As a result, the surface of the 3D printed form is not perfectly smooth, nor does it fit perfectly with the neighboring ceramic sherds (Figure 30).



*Figure 30:* The print is aligned with neighboring sherds. It is clear that it is not a perfect fit: gaps can be seen along the join, though it fits better against the sherd in the image on the right.

### 6.4 Conservation Applications and Challenges

Incorporating the 3D printed sherd into the physical reconstruction of the ceramic was not an effective approach as it was not a perfect fit and would subsequently cause shifts amongst all of the joints. The longevity of polylactic acid plastic is unknown regarding conservation and may not align with conservators' archival materials restrictions. To solve this, the printed sherd was cast in a two-part silicon rubber material. Tinted plaster was poured into the silicon mold so that the loss compensation of the ceramic vessel could be accomplished with a conservation-friendly material (Figure 32). The silicon rubber mold and, subsequently, the plaster picked up the textured surface of the printed sherd. Unlike the PLA plastic, the plaster can be easily sanded

and shaped to create a smooth surface and flush joins; the PLA plastic cannot be easily processed to facilitate a better fit.



*Figure 31:* The digitally modelled and 3D printed body sherd did not fit well with the corresponding rim sherd, specifically at a point of overlap (highlighted in yellow). The ill-fitting nature along this edge made it impossible to include in the reconstruction.



*Figure 32:* The printed sherd was cast in a two-part silicon rubber. This mold was then used to cast the shape of the 3D print in a tinted plaster. The plaster sherd is a closer color match to the ceramic substrate and can be easily sanded and carved as needed to provide the best fit possible for the accurate reconstruction of the ceramic. Here, the lines captured from the printed form are evident on the plaster cast in addition to a seam from the two halves of the silicon mold.

There are several factors to consider regarding the application of this process to archaeological ceramics that this experiment does not account for, namely, that the test material was not an archaeological ceramic; it was even and symmetrical and the break edges were fresh and well-fitting. The modelling processes described were successful by exploiting the near perfect axial symmetry of the ceramic vessel. Archaeological ceramic vessels were formed through coil construction, slab construction, and wheel-finished coil construction – none of which result in perfectly symmetrical pieces. Though, any issues that may arise from this could be avoided by careful manipulation of the digital sherds into the best placement possible. Secondly, archaeological ceramics do not necessarily have clean break edges due to weathering during burial. The effects of this remain to be tested, but smooth edges could easily assist the process as 3D printed pieces do not have to adhere to small details in break topography or could detract from the process as digital modelling could be more difficult in the increased presence of gaps.

## 7. Conclusions

Digital technologies in cultural heritage fields are likely to become a much more regularly used; it is therefore necessary to consider the benefits of these techniques in conservation. Though the everyday applications of 3D data acquisition, modeling, and printing in conservation are hardly commonplace, this experiment proves that they can be used by a non-specialist. The technologies and methods put forth in this process can be applied to different materials and can easily be altered to better accommodate another object's needs. The Artec Space Spider was best suited for the needs of this project; it was faster than the Next Engine laser scanner, the models created from the acquired points were of a high (enough) resolution, and the digital models were much smaller which made using them much more feasible on a personal computer. The reconstruction of the ceramic and the creation of new mesh were successfully performed in Blender. The process required practice and patience for the user to become familiar with the software. Modeling irregular shapes, or losses on asymmetrical objects cannot be done using this process, though it is undoubtedly possible using the same software. The 3D print, while not a perfect fit, was a useful tool in creating a fill suitable for the conservation of the ceramic.

This experiment was conducted as a 'proof-of-process' procedure in using digital technologies as part of a standard conservation treatment specifically addressing reconstruction and loss compensation, and it yielded promising results. Perhaps more importantly, this project was approached from the standpoint of a conservator without a computer science background; no specific algorithms were written or attempted for automated reconstruction. Most of the referenced studies had the benefit of computer scientists for such reasons and whose expertise expedited each respective process. This is not a realistic expectation for the average conservation treatment. Rather, an entirely user-activated system for reconstruction and modeling was established as a way to test the abilities of the conservator and the usability of modeling software as an approach to the treatment of a regular ceramic vessel. By outlining, in

detail, the specific modelling functions used in the digital reconstruction and the creation of new mesh for a fragmented and incomplete ceramic vessel this experimental process can be used as a platform from which to expand and build on digital procedures in conservation.



## Bibliography

- Adan, A., A. Salamanca, and P. Merchan. 2012. "A Hybrid Human-Computer Approach for Recovering Incomplete Cultural Heritage Pieces." *Computers & Graphics* 36 (1): 1-15.
- Arbace, Lucia, Elisabetta Sonnino, Marco Callieri, Matteo Dellepiane, Matteo Fabbri, Antonio Iaccarino Idelson, and Roberto Scopigno. 2013. "Innovative Uses of 3D Digital Technologiesto Assist the Restoration of a Fragmented Terracotta Statue." *Journal of Cultural Heritage* 14 (4): 332-345.
- Barreau, J-B., T. Nicolas, G. Bruniaux, E. Petit, Q. Petit, Y. Bernard, R.Gaugne, and V. Gouranton. 2014. "Photogrammetry Based Study of Ceramics Fragments." *International Journal of Heritage in the Digital Era* 3 (4): 643-656.
- Bernardini, F., H. Rushmeier, I.M. Martin, J. Mittleman, and G. Taubin. 2002. "Building a Digital Model of Michelangelo's Florentine Pieta." *IEEE Computer Graphics and Applications* 22 (1): 59-67.
- Berndt, E., and J. Carlos. 2000. "Cultural Heritage in the Mature Era of Computer Graphics." *IEEE Computer Graphics and Applications* 20 (1): 36-37.
- Brown, Benedict, Lara Laken, Philip Dutre, Luc Van Gool, Szymon Rusinkiewicz, and Time Weyrich. 2012. "Tools For Virtual Reassembly of Fresco Fragments." *International Journal of Heritage in the Digital Era* 313-330.
- Bruno, F., S. Bruno, G. De Sensi, M.L. Luchi, S. Mancuso, and M. Muzzupappa. 2010. "From 3D Reconstruction to Virtual Reality: A Complete Methodology for Digital Archaeological Exhibition." *Journal of Cultural Heritage* 11 (1): 42-49.
- Callieri, M., P. Cignoni, M. Dellapiane, G. Ranzuglia, and R. Scopino. 2011. "Processing a Complex Architectural Sampling with MeshLab: The Case of Piazza Della Signoria." 3D-ARCH.
- Carrozzino, M., and M. Bergamasco. 2010. "Beyond Virtual Museums: Experiencing Immersive Virtual Reality in Real Museums." *Journal of Cultural Heritage* 11 (4): 452-458.
- Chandrakar, A., Y. Zhang, F. Laroche, and A. Bernard. 2017. "Physical Assembly Sequence Optimisation for Developing an Integrated 3D Reconstruction Method." *Virtual and Physical Prototyping* 173-190.
- Chua, C. K., S. M. Chou, and T. S. Wong. 1998. "A Study of the State-of-the-Art Rapid Prototyping Technologies." *The International Journal of Advanced Manufacturing Technology* 146-152.
- Cignoni, P., M. Callieri, M. Corsini, M. Dellepiane, F. Ganovelli, and G. Ranzuglia. 2008. "MeshLab: An Open-source Mesh Processing Tool." Eurographics Italian Chapter Conference.

- Cignoni, P., M. Corsini, M. Dellepiane, G. Ranzuglia, M. Vergauven, and L. Van Gool. 2008. "MeshLab and Arc3D: Photo-reconstruction and Processing 3D Meshes." Open Digital Cultural Heritage Systems Conference.
- Cohen, Fernand, Zexi Liu, and Taslidere Ezgi. 2013. "Virtual Reconstruction of Archaeological Vessels Using Expert Priors and Intrinsic Differential Geometry Information." *Computers & Graphics* 41-53.
- Collins, Tim, Sandra I. Woolley, Luis Hernandez Munoz, Andrew Lewis, Eugene Ch'ng, and Erlend Gehlken. 2014. "Computer Assisted Reconstruction of Virtual Fragmented Cuneiform Tablets." *Virtual System & Multimedia*. Hong Kong: IEEE. 70-77.
- Counts, Derek B., Erin Walcek Averett, and Kevin Gartski. 2016. "A fragmented past: (re)constructing antiquity through 3D artefact modelling and customised structured light scanning at Athienou-Malloura, Cyprus." *Antiquity* 206-218.
- Dellepiane, Matteo, Marco Callieri, Massimiliano Corsini, and Roberto Scopigno. 2012. "Using 3D Models for Study and Restoration of Cultural Heritage Artifacts." In *Digital Imaging for Cultural Heritage Preservation*, edited by Filippo Stanco, Sebastiano Battiato and Giovanni Gallo, 37-68. CRC Press, Taylor & Francis Group.
- Díaz-Marin, Carmen, Eduardo Vendrell-Vidal, Elvira Aura-Castro, Andrea F. Abate, Carlos Sánchez-Belenguer, and Fabio Narducci. 2015. "Virtual Reconstruction and Representation of an Archaeological Terracotta Statue." *Digital Heritage (IEEE)* 2: 699-702.
- Earl, G., K. Martinez, and T. Malzbender. 2010. "Archaeological Application of Polynomial Texture Mapping: Analysis, Conservation and Representation." *Journal of Archaeological Science* 37 (8): 2040-2050.
- Elston, M. 1990. "Technical and Aesthetic Consideration in the Conservation of Ancient Ceramics and Terracotta Objects in the J. Paul Getty Museum: Five Case Studies." *Studies in Conservation* 35 (2): 69-80.
- Etre, K., and A. Hight. 2016. "Technology from 2,000 Years Ago and Today; Using 3D Printing and Scanning to Reconstruct a Kylix by the Potter Euphronios." Edited by Lynn Grant, Molly Gleeson and Nina Owzcarek. Philadelphia, PA: University of Pennsylvania Museum of Archaeology and Anthropology.
- Evgenikou, V., and A. Georgopoulos. 2015. "Investigating 3D Reconstruction Methods for Small Artifacts." *The International Archives of the Photogrammetry, Remote Sensing and Spatial Information Sciences* 101-108.
- Geary, Angela. 2004. "Three-dimensional virtual restoration applied to polychrome sculpture." *The Conservator* 28 (1): 20-34.
- Gomes, L., O.R.P. Bellon, and L. Silva. 2014. "3D Reconstruction Methods for Digital Preservation of Cultural Heritage: A Survey." *Pattern Recognition Letters* 3-14.

- Graham, C. A., K. G. Akoglu, A. W. Lassen, and S. Simon. 2017. "Epic Dimensions: A Comparative Analysis of 3D Acquisition Methods." *International Archives of the Photogrammetry, Remote Sensing and Spatial Information Sciences*.
- Guidi, Gabriele, J-A. Beraldin, and C. Atzeni. 2004. "High-Accuracy 3-D Modeling of Cultural Heritage: The Digitizing of Donatello's "Maddalena"." *IEEE Transactions on Image Processing* 13 (3): 370-380.
- Huang, Q.X., S. Flöry, N. Gelfand, M. Hofer, and H. Pottmann. 2006. "Reassembling Fractured Objects by Geometric Matching." *ACM Transactions on Graphics (TOG)* 25 (3): 569-578.
- Jecić, Stjepan, and Nenad Drvar. 2003. "The Assessment of Structured Light and Laser Scanning Methods in 3D Shape Measurements." *4th International Congress of Croatian Society of Mechanics*. Bizovac, Croatia. 237-244.
- Kampel, M., and R. Sablatnig. 2004. *3D Puzzling of Archaeological Fragments*. Vol. 2, in *Proceedings of 9th Computer Vision Winter Workshop*. Slovenian Pattern Recognition Society.
- Kampel, Martin, and Robert Sablatnig. 2003. "Virtual Reconstruction of Broken and Unbroken Pottery." Fourth International Conference on 3-D Imaging and Modeling.
- Kersten, T. P., H. J. Przybilla, M. Lindstaedt, F. Tschirschwitz, and M. Misgaiski-Hass. 2016. "Comparative Geometrical Investigations of Hand-held Scanning Systems." *Int. Soc. Photogram. Remote Sens.*
- Kleber, F., and R. Sablatnig. 2009. "A Survey of Techniques for Document and Archaeology Artifact Reconstruction." *International Conference in Document Analysis and Recognition*.
- Koutsoudis, A., G. Pavlidis, F. Arnaoutoglou, D. Tsiafakis, and C. Chamzas. 2009. "A Tool for Generating 3D Models of Ancient Greek Pottery." *Journal of Cultural Heritage* 10 (2): 281-295.
- Levoy, M., K. Pulli, B. Curless, S. Rusinkiewicz, D. Koller, L. Pereira, M. Ginzton, et al. 2000. "The Digital Michelangelo Project: 3D Scanning of Large Statues." *Proceedings of the 27th Annual Conference on Computer Graphics and Interactive Techniques*. ACM Press/Addison-Wesley Publishing Co. 131-144.
- Mellado, N., P. Reuter, and C. Schlick. 2010. "Semi-Automatic Geometry-driven Reassembly of Fractured Archaeological Objects." *VAST 2010: The 11th International Symposium on Virtual Reality, Archaeology and Cultural Heritage*.
- Morcillo, J. M., F. Schaaf, R. H. Schneider, and C. Y. Robertson-von Trotha. 2017. "Authenticity Through VR-based Documentation of Cultural Heritage. A theoretical approach based on conservation and documentation practices." *Virtual Archaeology Review* 35-43.
- Neumuller, M., A. Reichinger, F. Rist, and C. Kern. 2014. "3D Printing for Cultural Heritage: Preservation, Accessibility, Research and Education." In *3D Research Challenges in*

- Cultural Heritage: A Roadmap in Digital Heritage Preservation*, by Marinos Ioannides and Ewald Quak, 119-134. Springer-Verlag Berlin Heidelberg.
- Pavlidis, George, Anestis Koutsoudis, Fotis Arnaoutoglou, Vassilios Tsioukas, and Christodoulos Chamzas. 2007. "Methods for 3D Digitization of Cultural Heritage." *Journal of Cultural Heritage* 8 (1): 93-98.
- Pieraccini, Massimiliano, Gabriele Guidi, and Carlo Atzeni. 2001. "3D Digitizing of Cultural Heritage." *Journal of Cultural Heritage* 2: 63-70.
- Pintus, R., K. Pal, Y. Yang, T. Gobbetti, and H.E. Rushmeier. 2014. "Geometric Analysis in Cultural Heritage." *GCH* 117-133.
- Pires, H., P. Ortiz, P. Marques, and H. Sanchez. 2006. "Close-range Laser Scanning Applied to Archaeological Artifacts Documentation. Virtual Reconstruction of an XVIth Century Ceramic Pot." Edited by M. Ioannides, D. Arnold, F. Niccolucci and K. Mania. *The 7th International Symposium on Virtual Reality, Archaeology and Cultural Heritage VAST*.
- Ravanelli, Roberta, Martina Di Rita, Andrea Nascetti, Mattia Crespi, Lorenzo Nigro, Daria Montanari, and Federica Spagnoli. 2017. "Penguin 3.0 - Capturing Small Finds in 3D." *Mediterranean Archaeology and Archaeometry* 17 (2): 49-56.
- Reed, Christopher. 2007. "Dazzlers: Ancient Reborn in Bright Array." *Harvard Magazine*. Harvard University, November-December.
- Sanchez-Belenguer, Carlos, and Eduardo Vendrell-Vidal. 2014. "An Efficient Technique to Recompose Archaeological Artifacts from Fragments." Virtual Systems & Multimedia (VSMM) International Conference.
- Scopigno, R., M. Callieri, P. Cignoni, M. Corsini, M. Dellepiane, F. Ponchio, and G. Ranzuglia. 2011. "3D Models for Cultural Heritage: Beyond Plain Visualization." *Computer* 48-55.
- Scopigno, R., P. Cignoni, N. Pietroni, M. Callieri, and M. Dellepiane. 2014. "Digital Fabrication Techniques for Cultural Heritage (STAR)." In *Eurographics Workshop on Graphics and Cultural Heritage*. The Eurographics Association.
- Shäfer, A., G. Bock, J. Sanday, and H. Leitte. 2015. "Virtually Reassembling Angkor-style Khmer Temples." *Digital Applications in Archaeology and Cultural Heritage* 2-11.
- Smithsonian Exhibits. 2017. *Making a 3D Printed Object Mount*. Accessed May 8, 2017. [https://www.si.edu/object/yt\\_Yi89d2CUvYM](https://www.si.edu/object/yt_Yi89d2CUvYM).
- Soile, S., K. Adam, C. Ioannidis, and A. Georgopoulos. 2013. "Accurate 3D Textured Models of Vessels for the Improvement of the Educational Tools of a Museum." *ISPRS-International Archives of the Photogrammetry, Remote Sensing and Spatial Information Sciences* 1 (1): 211-217.
- Soler, F., F. J. Melero, and M. V. Luzón. 2017. "A Complete 3D Information System for Cultural Heritage Documentation." *Journal of Cultural Heritage* 49-57.

- Stanco, F., S. Battiato, and G. Gallo, . 2011. *Digital Imaging ofr Cultural Heritage Preservation: Analysis, Restoration, and Reconstruction of Ancient Artworks*. CRC Press.
- Themistocleous, K., M. Ioannides, A. Aganiou, and D. G. Hadiimitsis. 2015. "The Methodology of Documenting Cultural Heritage Sites Using Photogrammetry, UAV, and 3D Printing Techniques: the case study of Asinou Church in Cyprus." *Third International Conference on Remote Sensing and Geoinformation of the Environment*. International Society for Optics and Photonics.
- Tsamoura, Efthymia, Nikos Nikolaidis, and Ioannis Pitas. 2012. "Digital Reconstruction and Mosaicing of Cultural Artifacts." In *Digital Imaging for Cultural Heritage Preservation: Analysis, Restoration, and Reconstruction of Ancient Artworks*, edited by Filippo Stanco, Sebastiano Battiato and Giovanni Gallo, 353-384. CRC Press, Taylor & Francis Group.
- Tsiafaki, D., A. Koutsoudis, F. Arnaoutoglou, and N. Michailidou. 2015. "Virtual Reassembly and Completion of a fragmentary Drinking Vessel." *Virtual Archaeology Review* (Universita Politècnica de València) 67-76.
- Willis, A., and D. Cooper. 2004. "Bayesian Assembly of 3-D Axially Symmetric Shapes from Fragments." *Computer Vision and Pattern Recognition*. 82-89.
- Willis, A.R., and D.B. Cooper. 2008. "Computational Reconstruction of Ancient Artifacts." *IEEE Signal Processing Magazine* 25 (4): 65-83.
- Zheng, S. Y., R. Y. Huang, J. Li, and Z. Wang. 2014. "Reassembling 3D Thing Fragments of Unknown Geometry in Cultural Heritage." *ISPRS Annals of the Photogrammetry, Remote Sensing and Spatial Information Sciences* 393.