

# Lawrence Berkeley National Laboratory

## Recent Work

### Title

APPLICATIONS OF A SIMPLIFIED MODEL FOR PREDICTING AIR FLOWS IN MULTIZONE STRUCTURES

### Permalink

<https://escholarship.org/uc/item/6093n7jr>

### Authors

Haugen, T.  
Feustel, H.E.

### Publication Date

1987-07-01



# Lawrence Berkeley Laboratory

UNIVERSITY OF CALIFORNIA

## APPLIED SCIENCE DIVISION

RECEIVED  
LAWRENCE  
BERKELEY LABORATORY

JAN 3 1989

LIBRARY AND  
DOCUMENTS SECTION

### Applications of a Simplified Model for Predicting Air Flows in Multizone Structures

T. Haugen and H.E. Feustel

July 1987

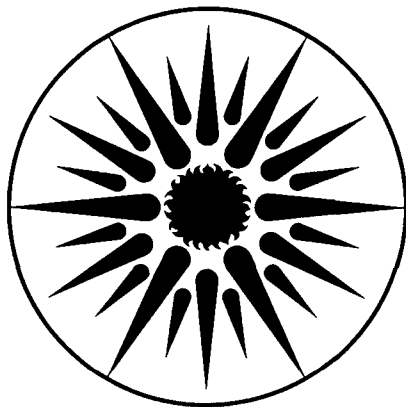

APPLIED SCIENCE  
DIVISION

LBL-23035  
c.2

## **DISCLAIMER**

This document was prepared as an account of work sponsored by the United States Government. While this document is believed to contain correct information, neither the United States Government nor any agency thereof, nor the Regents of the University of California, nor any of their employees, makes any warranty, express or implied, or assumes any legal responsibility for the accuracy, completeness, or usefulness of any information, apparatus, product, or process disclosed, or represents that its use would not infringe privately owned rights. Reference herein to any specific commercial product, process, or service by its trade name, trademark, manufacturer, or otherwise, does not necessarily constitute or imply its endorsement, recommendation, or favoring by the United States Government or any agency thereof, or the Regents of the University of California. The views and opinions of authors expressed herein do not necessarily state or reflect those of the United States Government or any agency thereof or the Regents of the University of California.

APPLICATIONS OF A SIMPLIFIED MODEL FOR  
PREDICTING AIR FLOWS IN MULTIZONE STRUCTURES

Tore Haugen

Norwegian Institute of Technology  
Trondheim - NTH, Norway

Helmut E. Feustel

Applied Science Division  
Lawrence Berkeley Laboratory  
1 Cyclotron Road  
Berkeley, California 94720

July 1987

**APPLICATIONS OF A SIMPLIFIED MODEL FOR  
PREDICTING AIR FLOWS IN MULTIZONE STRUCTURES**

Tore Haugen  
Norwegian Institute of Technology  
Trondheim-NTH, Norway

Helmut E. Feustel  
Lawrence Berkeley Laboratory  
Berkeley, CA 94720, U.S.A.

**Abstract**

A simplified pocket calculator model has been developed which can simulate the air flow distribution in multizone structures. The model is based on lumped parameters and includes several assumptions to simplify the description of air flow due to wind and stack effect and their superimposition. This paper gives a brief overview of the model and describes several applications. Results for simulation runs using the simplified model are compared with results obtained from a mainframe based research tool. The examples show that the simplified method can be used to predict air mass flows within reasonable accuracy for different types of buildings. We are able to calculate air flows due to wind or stack effect within a few percent difference from results calculated with a detailed model. We might expect larger differences when superimposing flows caused by different effects.

---

This work was supported by the Assistant Secretary for Conservation and Renewable Energy, Office of Building Energy Research and Development, Building Systems Division of the U.S. Department of Energy under Contract No. DE-AC03-76SF00098 and the Royal Norwegian Council for Scientific and Industrial Research under Contract No. BA7002.18414.

## Table of Symbols

$c_k$	pressure coefficient for surface element $k$ [-]
$c_{lee}$	pressure coefficient on leeward side [-]
$c_{wind}$	pressure coefficient on windward side [-]
$dz$	height gradient [m]
$f_{in}$	iteration damping factor [-]
$g$	acceleration of gravity [ $m/s^2$ ]
$h$	height of the building [m]
$j$	number of considered story [-]
$i$	iteration step [-]
$k$	number of stories [-]
$lee$	leeward side
$luv$	windward side
$n$	exponent of the pressure difference [-]
$p$	pressure [Pa]
$p_0$	atmospheric pressure [Pa]
$p_{dyn}$	dynamic pressure in the undisturbed flow [Pa]
$p_{in}$	inside pressure [Pa]
$p_k$	pressure at surface element $k$ [Pa]
$p_{out}$	outside pressure [Pa]
$\Delta p_{stack}$	pressure difference due to stack [Pa]
$\Delta p_{tot}$	pressure difference due to stack and wind action [Pa]
$\Delta p_{wind}$	pressure difference due to wind [Pa]
$sign$	sign of the following expression [-]
$t_{in}; t_{out}$	temperature inside; outside [ $^{\circ}C$ ]
$v$	wind speed [m/s]
$x, y, z$	coordinates [m]
$z_n$	neutral pressure level [m]
$z_0$	reference height for wind velocity measurements [m]
$D$	air permeability of the building component [ $m^3/h Pa^n$ ]
$D_{lee}$	air permeability of the leeward side of the building envelope [ $m^3/h Pa^n$ ]
$D_{res}$	resultant permeability [ $m^3/h Pa^n$ ]
$D_{shaft}$	air permeability from the story to the shaft [ $m^3/h Pa^n$ ]
$D_{total}$	air permeability of the total building envelope [ $m^3/h Pa^n$ ]
$Q$	air flow through a building component [ $m^3/h$ ]

$Q_{tot}$	superimposition of flows [ $m^3/h$ ]
$Q_{wind}$	air flow due to wind [ $m^3/h$ ]
$Q_{stack}$	air flow due to temperature differences [ $m^3/h$ ]
$T_{in}; T_{out}$	temperature inside; outside [ $K$ ]
$\alpha$	exponent [-]; value depends on terrain roughness
$\phi$	wind direction [ $^\circ$ ]
$\rho_{out}$	density of the outside air [ $kg/m^3$ ]
$\rho_{in}$	density of the inside air [ $kg/m^3$ ]

## 1. INTRODUCTION

Awareness of the air flow pattern in a building is particularly important when determining indoor air quality problems for the different zones in a building, smoke distribution during a fire, and space conditioning loads for calculating energy consumption. The correct sizing of necessary space conditioning equipment is also dependent upon accurate air flow information.

Infiltration is the pressure driven, uncontrolled flow of air through openings in the building envelope. Pressure differences are caused either by wind action, stack action or mechanical ventilation systems. Wind flows produce a pressure field around the building. Pressure differences between different location of the building envelope force air flows inside the structure. Temperature differences between the outside and inside of a building create air density differences that cause pressure gradients. Buoyancy forces try to eliminate these differences, causing a vertical stream of air inside the building depending.

A number of computer programs have been developed to calculate infiltration-related energy losses and the resultant air flow distribution in buildings [1]. Mainframe computers are the standard hardware used to host models designed to solve the set of nonlinear equations created by air flow patterns through building components. If the true complexity of air flows brought about by climatic variables is to be properly treated in multizone buildings, extensive information regarding flow characteristics and pressure distribution inside and outside the building is essential. To reduce the necessary input data required by detailed infiltration models, researchers have developed a variety of simplified models. Most of these models, including the one developed at the Lawrence Berkeley Laboratory [2], simulate infiltration associated with single-cell structures. (Air flow in a building that can be described as one fully-mixed space without any internal flow restrictions and no pressure gradients in the horizontal direction can also be calculated by using single-cell infiltration models.)

A high percentage of existing buildings, however, have floor plans that characterize them more accurately as multizone structures. Detailed infiltration models usually describe buildings as an interlaced grid of flow paths. In this system, the joints are the zones of the building, and the connections between the joints simulate the flow paths. The grid points outside the building mark the boundary conditions for wind pressure.

The duct system in buildings with mechanical ventilation systems, can be treated as another interior flow path, the fan being an additional source of pressure difference. The fan increases the pressure level between two joints according to the characteristic curve of the fan.

Due to the nonlinear dependency of the flow on the pressure difference, the pressure distribution is generally calculated in several iterations. For detailed multizone infiltration models describing buildings with complicated floor plans and solving the resulting set of nonlinear equations, a computer with a large storage capacity is needed. Although multizone models exist, the vast majority are 1) not readily available to the end user and 2) written as research tools requiring inordinate amounts of input data to describe the external pressure distribution and air permeability distribution of the building [1]. Furthermore, to determine the impact of infiltration and air flow patterns within buildings, engineers and architects need a simplified multizone infiltration model.



Therefore, LBL has developed a simplified model, categorizing buildings on the basis of their ratio of air permeability [3]. In this paper, applications of such a model are shown. Results for simulation runs using the simplified model are compared with results obtained from a mainframe based research tool.

<b>Table 1: Comparison of modeling strategies</b>		
Model	Advantage	Disadvantage
single-cell	easy to handle, requires few input data, provides reasonable accuracy	simulates only single cell structures; i.e., no internal flows or partitions
detailed	useful for larger buildings, measures internal flows, has good accuracy	requires extensive input and mainframe computer
simplified multizone	very useful for larger buildings, measures internal flows, is easy to use, requires reduced input, can be calculated on pocket calculator	reduced accuracy

## 2. SIMPLIFICATION

### 2.1 Overview

To simplify the calculation procedure, we adopted the following measures:

- 1) define a set of lumped parameters to describe the permeability distribution of the building
- 2) use a single exponent for the pressure distribution
- 3) use an average air density to calculate the infiltrating and exfiltrating air flows
- 4) calculate the wind- and stack-driven air flows separately
- 5) use superimposition to combine the air flows.

### 2.2 Resultant Permeability

The pressure drop along the crack length can be expressed in terms of friction and resistances. The air flow through building components is usually described by the empirical power-law equation

$$Q = D (p_1 - p_2)^n \quad (1)$$

A buildings effective air permeability for infiltration is often a combination of air permeabilities arranged in series and/or in parallel. For permeabilities having the same flow exponent, parallel permeabilities can be easily added, whereas those in a series arrangement have to be calculated as follows:

$$Q = D_{res} \left\{ (p_1 - p_2) + (p_2 - p_3) + \dots + (p_{k-1} - p_k) \right\}^n \quad (2)$$

$$Q = D_1 (p_1 - p_2)^n = D_2 (p_2 - p_3)^n = D_{k-1} (p_{k-1} - p_k)^n \quad (3)$$

$$D_{res} = \left\{ D_1^{-1/n} + D_2^{-1/n} + \dots + D_{k-1}^{-1/n} \right\}^{-n} \quad (4)$$

Figure 1 illustrates resultant air permeability for two resistances in a series arrangement with exponent  $n=2/3$ .

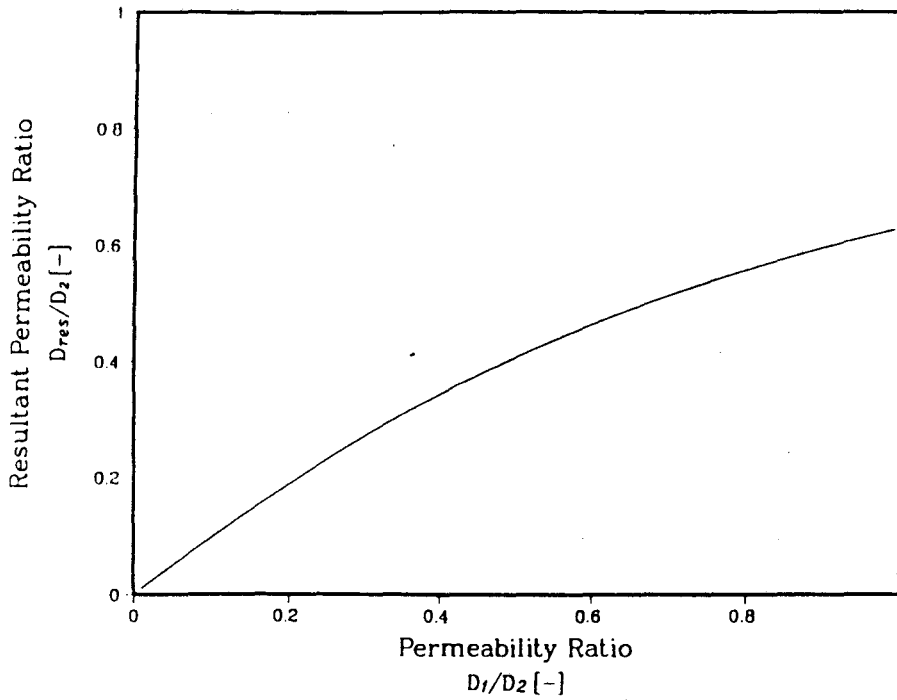

Fig. 1: Resultant permeability ratio versus permeability ratio

### 2.3 Superimposition of Flows

Air flows caused by separate mechanisms (such as wind and thermal buoyancy) are not additive because the flow rates are not linearly proportional to the pressure differences. To calculate the flows, superimposing the pressures is required.

$$Q_{tot} = D (\Delta p_{tot})^n \quad (5)$$

$$Q_{tot} \approx D (\Delta p_{wind, horizontal} + \Delta p_{wind, vertical} + \Delta p_{stack})^n \quad (6)$$

$$Q_{tot} \approx (Q_{wind,horizontal}^{1/n} + Q_{wind,vertical}^{1/n} + Q_{stack}^{1/n})^n \quad (7)$$

Because each mechanism may force the air to flow in a different direction, the superimposition of flows for each facade and story is expressed as:

$$Q_{tot} = \text{sign}(Q_{wind,horizontal} + Q_{wind,vertical} + Q_{stack}) \times \left| \left[ \text{sign}(Q_{wind,horizontal}) | Q_{wind,horizontal} |^{1/n} + \text{sign}(Q_{wind,vertical}) | Q_{wind,vertical} |^{1/n} + \text{sign}(Q_{stack}) | Q_{stack} |^{1/n} \right] \right|^n \quad (8)$$

Figure 2.1 and 2.2 show that both driving forces for natural ventilation can be calculated separately and superimposed to obtain the total natural ventilation.

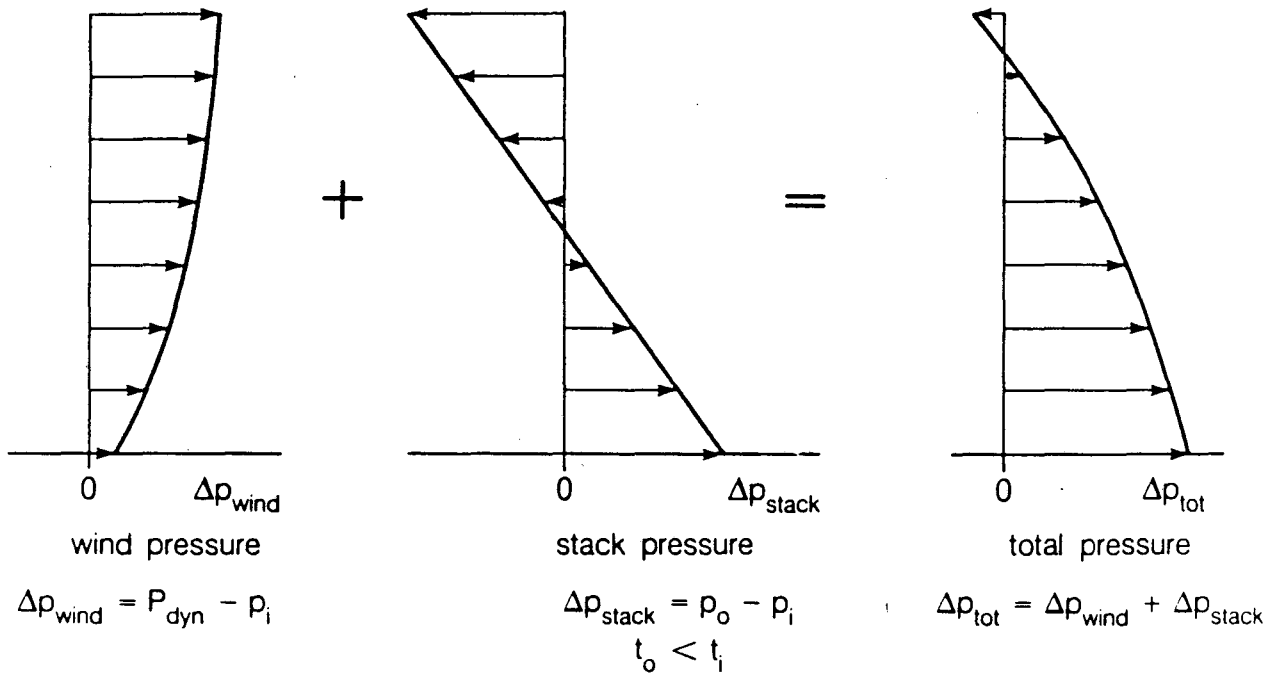

Fig. 2.1: Superposition of pressures for the windward side

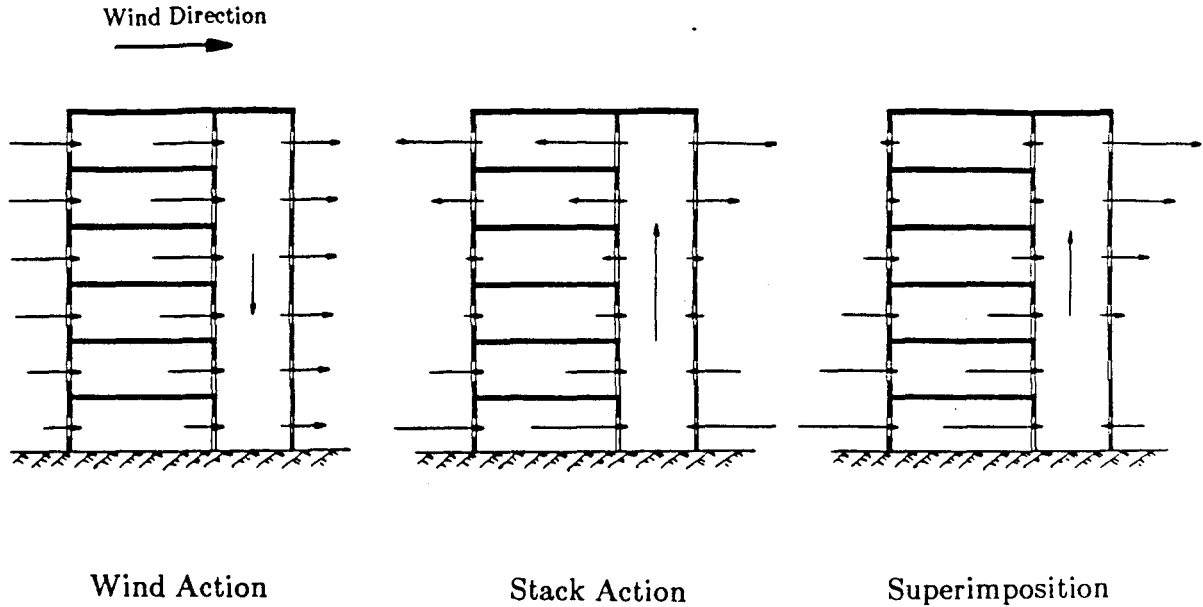

Fig. 2.2: Air flow pattern in multi-story building

## 2.4 Lumped Parameters

Several lumped parameters reflecting the different permeability distributions of the building's envelope have been found to describe the air flow distribution inside a building [3]. Krischer and Beck [4] used the following parameter to describe the envelope permeability ratio ( $epr$ ) of the whole building:

$$epr(\phi) = \frac{D_{lee, envelope}}{D_{total, envelope}} \quad (9)$$

The influence of the envelope permeability ratio on the resultant permeability of a structure and its infiltration is shown in Fig. 3. Due to the fact that the value of the resultant permeability is governed by the smallest permeability in a series arrangement, the infiltration rate for a given permeability of the total envelope reaches its maximum at an envelope permeability ratio of 0.5 (typical row house). Therefore, for buildings with the same overall leakage, but an uneven distribution of the air permeabilities between the leeward and the windward side, the infiltration will be smaller. The wind-driven infiltration under steady-state conditions will be zero if all air permeability is located on either side.

Another parameter to further differentiate construction types was obtained from the German standard for calculating heat loss in buildings, DIN 4701 [5]. Based on this parameter we introduced the ratio of the permeabilities from one floor to another, and the overall permeability of the building envelope. Equation 10 describes the vertical permeability ratio ( $vpr$ ) for a whole building of any given construction type.

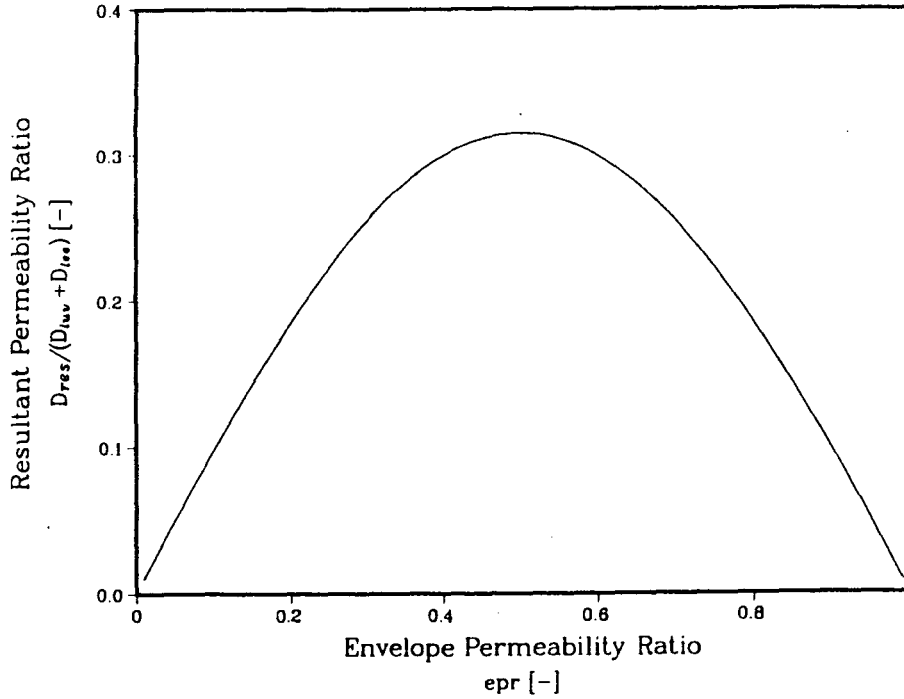

Fig. 3: Resultant permeability ratio versus envelope permeability ratio

$$vpr = \frac{D_{shaft}}{D_{total, envelope} + D_{shaft}} \quad (10)$$

With regard to thermal pressure distribution, two extremes exist — *story-type buildings* with no permeability between floors ( $vpr = 0$ ), and *shaft-type buildings* with no air-flow resistance between the different stories ( $vpr = 1$ ). The vertical permeability ratio for real houses is somewhere between these theoretical limits.

To describe the air-flow distribution for the different zones at the story level, we defined two additional lumped parameters. It was determined [3], that the internal air flows due to wind at the story level are directly dependent upon the ratios of the resultant permeabilities of the different zones. These are defined as the combination of all flow paths (parallel and series arrangements) from this zone to either the windward or leeward side of the building. The resultant permeability ratio ( $rpr$ ) is the ratio of the resultant permeability of the downstream side to all resultant permeabilities of this particular zone. The permeability ratio contains all information given by the outside permeability ratio together with all the flow paths not directly leading to the outside of the building.

$$rpr(\phi) = \frac{D_{res, zone, lee}}{D_{res, zone, total}} \quad (11)$$

The majority of the permeabilities have to be shared by different flow paths. Calculating the resulting permeability ratio for the internal flows may require an iteration procedure. To determine the initial value for the iteration process the outside permeability ratio ( $opr$ ) of the zone can be used. It describes the cross-ventilation of the zone, where cross-ventilation is the portion of the total air flow that exfiltrates the same zone it infiltrates.

Therefore, no permeabilities between internal zones have to be taken into consideration.

$$opr(\phi) = \frac{D_{zone,lee,outside\ envelope}}{D_{zone,outside\ envelope}} \quad (12)$$

## 2.5 Air Flow Compensation

Besides the determination of the permeability distribution and the pressure field around the building, the most difficult aspect of calculating wind-driven infiltration is the determination of the inside pressure distribution of the building. Different wind speeds in different heights also cause air flows through the shafts of a building. Majority of the time air flows due to stack action travel upwards ( $t_{in} > t_{out}$ ), but wind forces an air flow from the top to the bottom of the building.

Because the air-flow through the shaft due to wind action and thermal buoyancy causes no significant friction loss in the shaft, it can be assumed to have no pressure gradient inside the shaft itself.

$$0 = \sum_{j=1}^k \left\{ p_{in,j} - p_{shaft} \right\}^n \approx \sum_{j=1}^k \left\{ p_{in,j} - p_{shaft} \right\} \quad (13)$$

$$p_{shaft} = \frac{1}{k} \sum_{j=1}^k p_{in,j} \quad (14)$$

For this calculation, the inside pressures of story-type buildings may be used. The high pressures at the top of the building cause a downstream of infiltrated air in the shaft. This air is released into the lower levels of the building. This has a most significant effect for the flow distribution in houses having small *epr*-values.

For buildings having a flow resistance between the shaft and the floor landing, the following empirical equation gives the approximate value for the pressure of the landing as a function of the building's height above ground and the building type [6].

$$p_{in}(z, epr, 0 < vpr < 1) = p_{shaft} + \frac{\left\{ p_{in}(z=h, epr, vpr=0) - p_{shaft} \right\}}{h/2} (1 - vpr^n) (z - h/2) \quad (15)$$

For shaft type buildings the pressure of the landing becomes the shaft pressure itself.

### 3. CALCULATION PROCEDURE

#### 3.1 Air Flows sharing Air Permeabilities

The portion of air permeability used by different flow paths can be determined by splitting the single permeability by the same ratio as the parallel permeabilities belonging to these flow paths. A single permeability on the windward side of the building, which is used by flow paths through two different permeabilities on the leeward side can be calculated as follows:

$$D_{wind,1} = D_{wind,total} \frac{D_{res,lee,1}}{D_{res,lee,1} + D_{res,lee,2}} \quad (16)$$

The combination of permeabilities are, for the most part, not as simple as the above example. The resultant air permeability of a flow path may be a combination of series and parallel arrangements passing through a series of different zones. Therefore, the resultant permeabilities of the leeward side ( $D_{res,lee,1}; D_{res,lee,2}$ ) might not be determined yet. The share of the windward side permeability related to  $D_{res,lee,k,l}$  can be calculated by taking the leeward permeabilities of the considered zone and the  $rpr$ -differences into account.

$$D_{wind,k,l} = D_{wind,total} \frac{(rpr_k - rpr_l) D_{lee,k,l}}{\sum_{j=1}^n [(rpr_j - rpr_l) D_{lee,j,l}]} \quad (17)$$

The value of the resultant permeability ratio for the windward side of the building is defined as  $rpr = 0.0$  whereas the value for the leeward side becomes  $rpr = 1.0$ . Using these values, resultant permeability ratio differences between inside and outside can be calculated. The calculation becomes more time consuming if the air flow direction of one or more flow paths is different from that assumed by using the  $opr$ -values. In this case, part of the leeward flow path is not yet determined as it goes through different zones. Consequently, the portion of this additional leeward flow path is generally quite small compared to the direct flow through the zone. In most cases it is negligible. The main reason for the wrong initial direction on this particular flow is missing information on internal flow paths at the starting point. Usually, this occurs only in zones with  $opr$ -values lower than 0.5. The calculation procedure indicates the wrong flow direction normally after one or two iteration steps by producing negative results for some of the  $rpr$ -differences.

In order to prevent the iteration procedure from diverging, the newly calculated values should be accepted with caution. For further calculations, these values should be weighted by a factor which expresses the uncertainty of the results of the determined iteration step. Several tests have shown that

$$f_{in} = \frac{i}{i+1} \quad (18)$$

where the iteration step  $i$ , is a reasonable damping factor.

### 3.2 Pressure Distribution

Wind pressure is one of two main driving forces for natural ventilation. The pressure distribution around a building is usually described by dimensionless pressure coefficients -- the ratio of the surface pressure and the dynamic pressure in the undisturbed flow pattern:

$$c_k(x, y, z, \phi) = \frac{p_k(x, y, z) - p_0(z)}{p_{dyn}(z)} \quad (19)$$

with

$$p_{dyn}(z) = \frac{1}{2} \rho_{out} v^2(z) \quad (20)$$

The vertical profile of the wind speed in the atmospheric boundary layer is primarily dependent upon the roughness of the surface surrounding the building. The wind speed increases with the increasing height above ground. The wind velocity profile can be calculated by a power law expression.

$$\frac{v(z)}{v(z_0)} = \left\{ \frac{z}{z_0} \right\}^\alpha \quad (21)$$

Temperature differences between the outside and inside air create air density differences that cause pressure gradients. The stack-effect pressure gradient depends only upon temperature differences and the vertical dimension of the structure. The effect deals with the weight difference of the two adjacent columns of air. Buoyancy forces try to even out these differences, causing an overpressure at the top of the warm column of air, and an underpressure at the bottom. The value of pressure differences in high rise buildings located in cold climates can easily exceed those caused by wind effects. The theoretical value of the pressure difference depends on the gradient and distance of the neutral pressure level ( $z_n$ ). This is defined as the height on the building facade where, under calm conditions, no pressure difference exists between inside and outside. The vertical permeability distribution of the envelope determines the location of the  $z_n$ . For only one opening or for an extremely large opening relative to others, the neutral pressure level is at or near the center of the opening. For openings uniformly distributed vertically, the neutral pressure level is at almost midheight of the enclosure. Locating the neutral pressure level for simple enclosures with openings of known air flow characteristics are rather straightforward. For two openings separated by a known vertical height  $H$ , it can be found by the equation [7]

$$z_n = \frac{H}{1 + [(A_1/A_2)^2 (T_{in}/T_{out})]} \quad (22)$$



The stack effect (or thermal buoyancy) can be calculated by

$$(p_{in} - p_{out})_{stack} = g (\rho_{out} - \rho_{in}) (z - z_n). \quad (23)$$

### 3.3 Calculating Air Flows

Air flows due to the different effects have to be calculated separately. Wind induced flows can be calculated by multiplying each resultant permeability with the pressure difference between the windward and leeward side at a given height to the power of n.

$$Q_{wind,1} = D_{res,wind,1} [p(z)_{windward,1} - p(z)_{leeward,1}]^n \quad (24)$$

Flows caused by stack effect and the vertical flow in shaft type buildings can be calculated by multiplying the resultant permeability between the shaft and the outside of a building by the pressure difference between the shaft and the outside at the considered level above ground to the power of n.

$$Q_{stack,1} = D_{res,stack,1} |p(z)_{shaft} - p(z)_{out}|^n \quad (25)$$

## 4. USE OF THE SIMPLIFIED MODEL

### 4.1 General

In this section is shown the use and the accuracy of the simplified model. This model calculates the air flows for each zone in different buildings ranging from a single family building, to multistory apartment buildings. The model has been tested for different distribution of permeabilities, different outdoor temperatures, wind speeds and wind directions. All calculations with the simplified model are compared for accuracy with the results from a detailed multizone model [1,6] using the same kind of input for the permeabilities and weather conditions. The simplified model can be used with only a pocket calculator. Our first example is intended to illustrate a way for users not yet familiar with this method.

### 4.2 Boundary Conditions

The boundary conditions used in all examples and for calculations with both the simplified and the detailed mathematical model are given below:

outdoor temperature ( $t_{out}$ )	+5 °C and -10 °C
inside temperature ( $t_{in}$ )	20 °C
height of stories	3 m
wind speed at reference height ( $v_o$ )	4 and 8 m/s
wind direction perpendicular to windward side	
reference height for wind speed measurements ( $z_o$ )	10 m

exponent for vertical wind profile ( $\alpha$ )	1/3 *
exponent for pressure differences ( $n$ )	2/3
pressure coefficient windward side ( $c_{wind}$ )	1.
pressure coefficient leeward side ( $c_{lee}$ )	-0.3
air permeability of building components ( $D$ )	(see floor plans)

### 4.3 Example of a Calculation Procedure

The calculation procedure for a simple floor plan has been shown in a previous paper [6]. In order to get a complete overview of the use of the model, all the necessary steps for a calculation of a more complex building will be shown here. The building (Brunsbuettler Damm, Berlin) was built in 1965. An open staircase connects the 8 stories, containing 3 flats per floor. One of the flats has only windows to one side of the building. The main facade with the open stair (exterior wall as part of staircase) faces east.

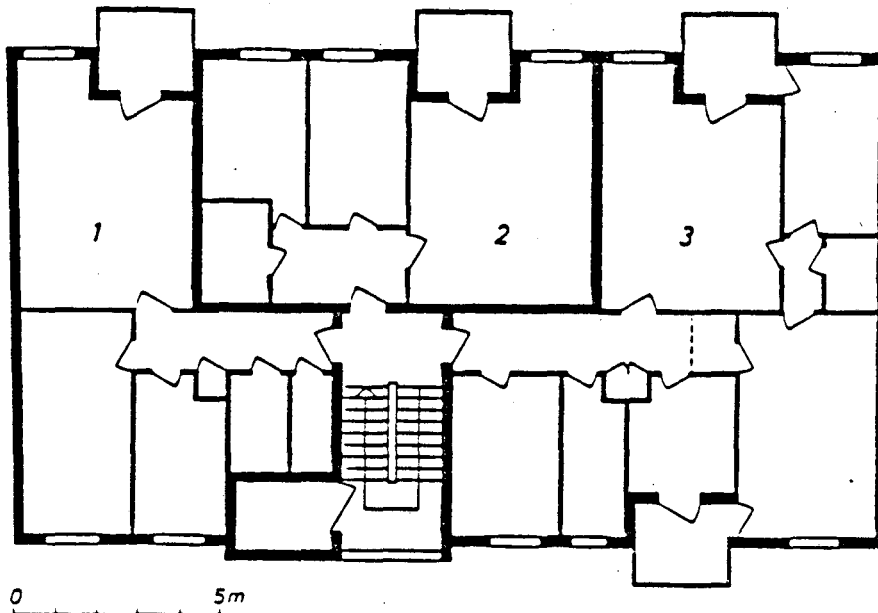

Fig. 4: Floor plan Brunsbuettler Damm 37

\* For details on wind profile see [4].

### 4.3.1 Infiltration - different zones

The calculation of the infiltration for different zones is more intricate, and will be shown step by step. The different permeabilities are shown in Fig. 5.1. As the flow paths and flow directions could be different for infiltration caused by wind and stack effect, one will have to calculate these flows separately and then superimpose them according to Equation 7 to get the final result.

**Table 4.1: Calculation Procedure Iteration step: Initial**

DESCRIPTION	#	FLAT # 1	FLAT # 2	FLAT # 3	STAIR (#4)
$D_{stair}$	1	---	---	---	---
$D_{door}$	2	18.	18.	18.	---
$D_{res:\#1,\#2}$	3	---	---	---	---
$D_{wind}$	4	4.3	---	19.6	20.
$D_{lee}$	5	8.6	11.6	17.1	---
$D_{lee, stair}$	6	---	---	---	---
$D_{res:\#2,\#6}$	7	---	---	---	---
$D_{res:\#3,\#6}$	8	---	---	---	---
$D_{res:\#4,(\#5-\#6)}$	9	---	---	---	---
opr $\frac{\#5}{\#3+\#4+\#5}$	10	.667	1.000	.466	0.000
opr-difference	11	.667	1.000	.466	---
share of $D_{stair}$	12	6.3	9.4	4.4	---

Iteration step : #1

DESCRIPTION	#	FLAT # 1	FLAT # 2	FLAT # 3	STAIR (#4)
$D_{stair}$	1	6.3	9.4	4.4	---
$D_{door}$	2	18.	18.	18.	---
$D_{res:\#1,\#2}$	3	5.52	7.58	4.05	---
$D_{wind}$	4	4.3	---	19.6	20.
$D_{lee}$	5	8.6	11.6	17.1	8.
$D_{lee, stair}$	6	4.83	11.6	2.93	---
$D_{res:\#2,\#6}$	7	4.43	8.79	2.81	---
$D_{res:\#3,\#6}$	8	---	---	---	---
$D_{res:\#4,(\#5-\#6)}$	9	---	---	---	---
rpr $\frac{\#5}{\#3+\#4+\#5}$	10	0.55	0.75	0.44	0.29
rpr-difference	11	0.26	0.46	0.15	---
share of $D_{stair}$	12	6.0	10.6	3.5	---

*Windeffect - story type building*

Considering the building first as a story type building with no connection between the different floors ( $vpr=0.0$ ). The first step is to find the flow paths for each story, keeping in mind, that air flows from zones with low rpr-values to those with high rpr-values.

The flow paths for the given building using  $opr$ -values as initial values for the resultant permeability ratio are illustrated in Fig. 5.1. The  $opr$ -values are 0.667 for flat 1, 1.0 for flat 2, 0.446 for flat 3 and 0.0 for the staircase (number 4). This is the initial step; for each next iteration step one will have to follow the procedure below. The calculated values are weighted by a iteration factor  $f_{in}$ , which expresses the uncertainty of the the result of the determined iteration step (Equation 18).

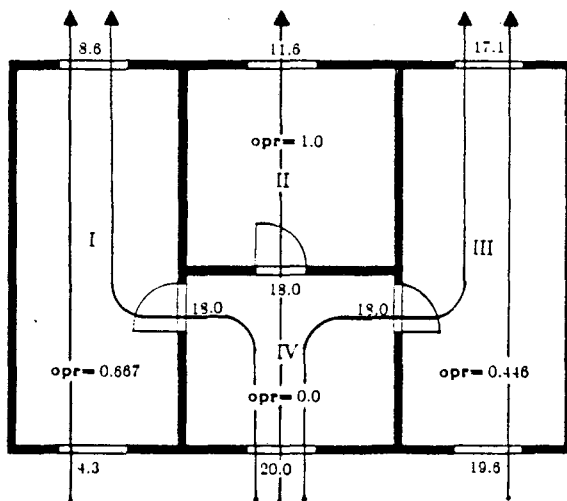

Fig. 5.1: Initial step - Assumed flow paths

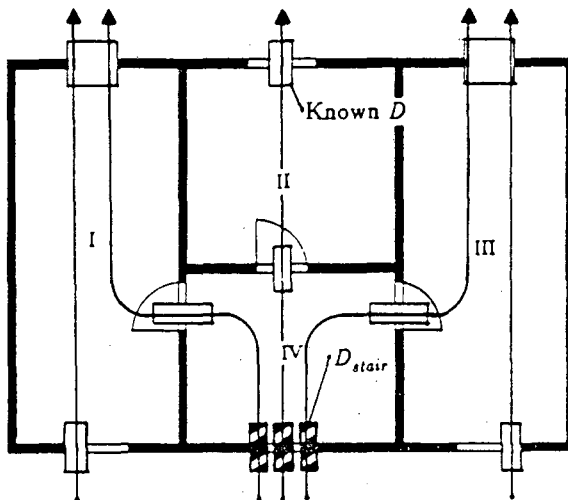

Fig. 5.2: Step #1 - Finding  $D_{stair}$

The numbers given in the following description relate to the steps in Table 4.1 and Figs. 5.2 - 5.5.

1.  $D_{stair}$  for each flat is given as the share of the windward permeability in the staircase.
2. Initial value; no changes.
3.  $D_{res}$  as the resultant of  $D_{stair}$  and  $D_{door}$  for each flat. This value can be found by using the table of resultant permeabilities for two permeabilities in a series arrangement (Appendix I).
4. Initial value; no changes.
5. Initial values; except for  $D_{lee}$  staircase, which equals the sum of  $D_{res:\#2,\#6}$  for flat 1, 2 and 3 multiplied with the damping factor  $f_{in}$  (here 0.5 for  $i=1$ ).
6.  $D_{lee,stair}$  is the share of the flat's leeward permeability  $D_{lee}$  belonging to the flow path including  $D_{res}$ . It is found by splitting the permeability by the same ratio as the parallel permeabilities (Equation 16).
7.  $D_{res:\#2,\#6}$  is the resultant permeability of the leeward flow path of the staircase.
8.  $D_{res:\#3,\#6}$  is the resultant permeability of the flow path through the staircase to leeward side of the flat. These are only necessary at the last iteration step for calculation of the

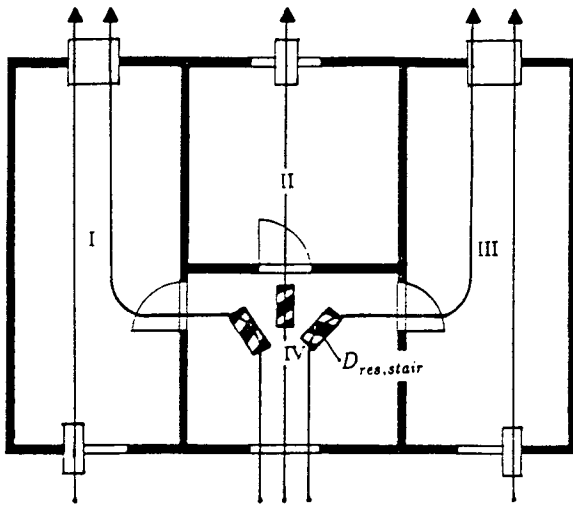

Fig. 5.3: Step #3 - Finding  $D_{res}$  for  $D_{stair}$  and  $D_{door}$

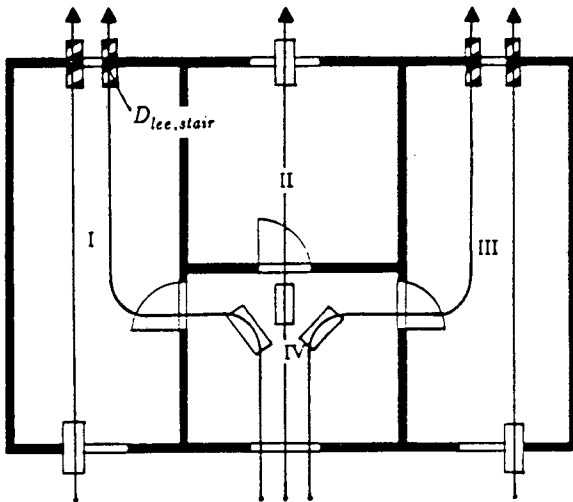

Fig. 5.4: Step #6 - Splitting  $D_{lee}$  to find  $D_{lee,stair}$

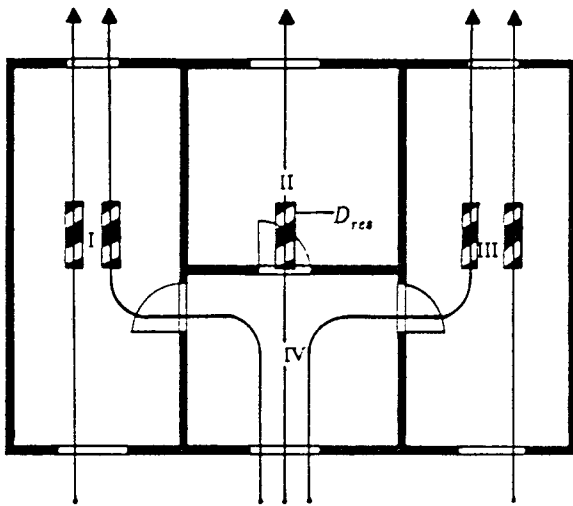

Fig. 5.5: Step #8, #9 - Finding  $D_{res}$  for all flows

air flow, and are therefore not calculated at each iteration.

9.  $D_{res:\#4,(\#5-\#6)}$  is the resultant permeability of the through flow from the windward to the leeward side of the flat. These are also only necessary to find at the final iteration.

10. New  $rpr$ -values are calculated in order to continue with the next iteration step.  $D_{res}$  values are always multiplied by the iteration factor  $f_{in}$ .

11.  $Rpr$ -differences are the differences between  $rpr$ -values for the stair and the flats. They are used to find  $D_{stair}$  for the next iteration step.

12. Share of  $D_{stair}$  is found by dividing  $D_{wind}$  for the stair by the sum of  $rpr$ -differences from step 11, and multiply by the  $rpr$ -difference for the flat. This value will also be the value for  $D_{stair}$  (#1) in the next iteration step.

The detailed result for the second and third iteration step is shown in Appendix II. The differences in the air mass flow for the different flow paths are very small for this building. The only exception is the flow through the door of flat 3. But even if the mass flow for this path changes about 50% with 5 iteration steps, the change of the total flow for the flat 3 is only 2.5%.

Therefore, if the total air flow per zone is more important than the air flow for a particular flow path, the first iteration step gives a reasonable result. If, however, the values for a particular flow path is important, the number of iteration steps is determined by the smallest  $rpr$ -difference between zones.

### *Wind effect - shaft type building*

The pressure in the shaft due to wind is dependent on the wind pressure profile, which causes high pressures in the upper flats and low pressures in the lower flats. The high pressures at the top of the building cause a downstream of infiltrated air in the shaft. This air is released into the the lower levels of the building, so that the pressure differences between the staircase and the flats becomes very small and even negative. Because of no significant friction loss in the shaft, it can be assumed, to have no pressure gradient inside the shaft itself. We can determine the shaft pressure by averaging the pressure in the staircase for the story type building (Equation 14).

### *Stack effect - shaft type building*

The difference in thermal pressures for a given temperature difference under calm conditions is a linear function of the distance of the height above ground from the neutral pressure level (Equation 22).

$D_{res}(z)$  is the resultant permeability calculated for the arrangement of permeabilities in series or parallel between the zone where the stack pressure occurs (here the stair shaft) and the outdoor.

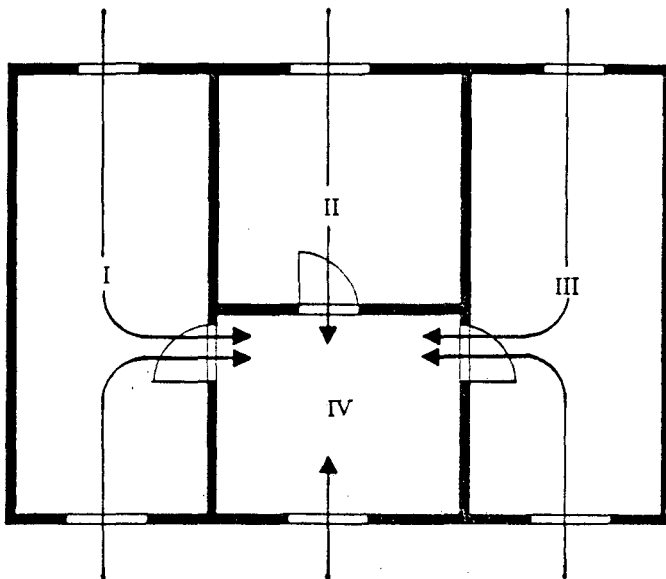

**Fig. 5.6:** Flowpaths below  $n_z$  due to stackeffect

Figure 5.6 shows the flow paths and the permeabilities for the first floor (will be opposite for floors above  $z_n$ ). The resultant permeabilities again can be found using the table for two permeabilities in a series arrangement (Appendix I).

### 4.3.2 Resulting air flows

The air flows due to different effects are calculated separately using Eq. 24 and 25 with  $n = 2/3$ . Table 4.2 shows air mass flows calculated with the simplified model for the following cases: *wind effect - story type building*; *wind effect shaft type building*; *stack effect*; *stack- and wind effect* for the first floor in a shaft type building. The detailed model has been used to calculate the mass flows for the same effects.

model / case	Flat 1			Flat 2	Flat 3		
	wind	lee	door	door	wind	lee	door
<i>Simplified:</i>							
wind (story)	18.4	-40.5	22.1	44.5	76.2	-86.7	10.4
wind (shaft)	16.9	-43.3	28.6	48.9	73.4	-89.1	25.9
stack	23.9	47.9	-71.8	-67.9	61.0	53.3	-114.2
stack + wind	32.7	13.0	-59.3	-36.4	107.0	-58.8	-106.5
<i>Detailed:</i>							
wind (story)	18.5	-40.2	21.8	44.6	76.4	-85.2	8.8
wind (shaft)	16.4	-43.3	26.9	48.9	69.5	-89.5	20.3
stack	24.1	48.3	-72.4	-68.0	58.2	50.8	-109.0
stack + wind	35.1	14.6	-49.7	-32.8	126.9	-41.7	-85.2

The results of the simplified model are very close to those of the detailed model for flows caused by a single effect. Differences for flows caused by either wind or stack effect are in absolute values only a few percent. For the flow through the door in flat 3 the difference 18% for the *wind(story)* case, mainly because of its low absolute value.

The major differences appear for a situation with flows caused by both wind- and stack effect. The differences are up to 20% for flows through flat 1 (case: stack + wind), and up to 40% for flat 3. This is, if we express the differences as percent of a single flow. If we express the difference between the two methods as the difference for a single flow path in relation to the total airflow through one zone, the maximum difference for flows through flat 3 is 16.8%. As this is a more correct way of expressing the percentages for situation with very low air mass flows, this calculation procedure will be used in the following. To get reasonable results for the total mass flow through a zone and to find correct flow directions is very important.

Table 4.2 also shows that the superposition changes the mass balance for the zone. For each zone the sum of mass flows should by definition equal zero; as is the case for both wind and stack effect separately. After superimposing the flows, the mass flow balances are either positive or negative. This is due to the simplification procedure.

We have tried another approach, where we only superimpose two of the flows (here flow through windward and leeward side) through a zone with 3 different flows, and then in the finale step find the third mass flow from a mass flow balance of zero. But overall results are not better.

### 4.3.3 Changing outdoor temperature any wind speed

A building might be more or less dependent on either wind or stack effect. Table 4.3 shows the differences between the two methods for both wind and stack effect with varying outdoor temperature and wind speed.

<b>Table 4.3:</b> Air mass flows for the 1th floor [kg/h], Variable temperature and wind speed, Wind perpendicular to facade, Stack + wind effect, 5th iteration step							
$v_o$ $t_{out}$	Flat 1			Flat 2	Flat 3		
	wind	lee	door	door	wind	lee	door
<i>Simplified:</i>							
4 m/s, +5 °C	24.2	-21.3	-28.6	11.7	85.8	-68.8	-60.1
4 m/s, -10 °C	32.7	13.0	-59.3	-36.4	107.0	-58.8	-106.5
8 m/s, +5 °C	45.5	-91.1	40.8	97.7	184.1	-200.8	-23.1
8 m/s, -10 °C	54.0	-86.9	2.0	86.8	207.9	-206.8	-78.7
<i>Detailed:</i>							
4 m/s, +5 °C	26.3	-17.1	-9.21	15.8	99.7	-57.0	-42.7
4 m/s, -10 °C	35.1	14.6	-49.7	-32.8	126.9	-41.7	-85.2
8 m/s, +5 °C	46.2	-91.2	45.0	100.0	192.8	-195.0	2.2
8 m/s, -10 °C	55.9	-85.9	30.0	91.6	230.0	-190.2	-39.8
<i>Difference %</i>							
4 m/s, +5 °C	-8.0	16.0	73.7	-26.0	-14.0	11.8	17.4
4 m/s, -10 °C	-4.0	3.2	19.3	11.0	15.7	13.5	16.8
8 m/s, +5 °C	-1.1	-0.1	-4.6	-2.3	-4.5	3.0	13.1
8 m/s, -10 °C	-2.2	1.2	-32.6	-5.3	-9.6	7.2	16.9

Table 4.3 shows, that the flow directions calculated by the simplified model are correct with one exception. For a situation with 4 m/s wind speed and +5 °C the maximum difference between the simplified and detailed method is 73.7%, while a situation with 8 m/s and +5 °C gives a maximum difference of 13.1% (not the same flow path). This does not mean that the simplified method is more correct for high wind speeds. If we had a situation with wind effect only, we would observe the same percent differences between the simplified and the detailed method for both 4 and 8 m/s. The differences is an effect of the superposition and there is no general trend depending on either wind speed or temperature differences.



#### 4.3.4 Number of iteration steps

In a calculation made by hand only, the time spent is nearly proportional with the number of iteration steps. Table 4.2 is based on a calculation procedure with 5 iteration steps. If we consider more or less iteration steps, as shown in Table 4.4, this does not change the picture dramatically.

	Flat 1			Flat 2	Flat 3		
	wind	lee	door	door	wind	lee	door
<b>wind (story)</b>							
<i>simplified</i>							
1. step	18.0	-41.2	23.2	40.8	73.5	-88.7	15.2
3. step	18.3	-40.7	22.4	43.7	75.5	-87.2	11.7
6. step	18.4	-40.4	22.0	44.8	76.5	-86.5	10.0
10. step	18.5	-40.3	21.8	45.3	76.9	-86.1	9.2
15. step	18.5	-40.4	22.0	45.3	77.7	-86.0	8.9
<i>detailed</i>	18.5	-40.2	21.8	44.6	76.4	-85.2	8.8
<b>wind + stack</b>							
<i>simplified</i>							
1. step	32.5	12.0	-58.9	-40.5	104.9	-61.1	-104.9
3. step	32.7	12.7	-59.2	-37.3	106.5	-59.4	-105.9
6. step	32.7	13.1	-59.4	-36.0	107.2	-58.6	-106.2
10. step	32.8	13.3	-59.5	-35.4	107.6	-58.1	-106.4
15. step	32.7	13.1	-59.4	-35.4	107.7	-58.0	-106.5
<i>detailed</i>	35.1	14.6	-49.7	-32.8	126.9	-41.7	-85.2

If we increase the number of iteration steps to fifteen the differences for the air flows caused by wind on a story type building are less than two percent. By increasing the number of iterations the approach becomes better and better. This is not clearly the result if we consider flows caused both by wind and stack effect. Increasing the number of iteration steps has no significant effect. The reason is, as mentioned above, the errors incorporated by superimposing flows. In many cases a few iteration steps will be sufficient.

#### 4.3.5 Overall infiltration due to wind

For some applications it might be sufficient to estimate the overall infiltration rate for a building, without determining the individual flow paths. The infiltration rate due to wind for the whole building can be calculated using the permeabilities shown in Fig. 5.1. Each story is hereby treated as a single-zone building.

The envelope permeability ratio  $epr$  is given by:

$$epr = \frac{D_{lee, envelope}}{D_{total, envelope}} = \frac{37.3}{81.2} = 0.459$$

The overall infiltration rate due to wind can be calculated using Fig. 3 and the resultant permeabilities listed in Appendix I. For the first story of a story-type building at wind speeds 4 m/s and a pressure distribution according to Krischer and Beck [4], we calculate an infiltration rate of 133  $m^3/h$ . This value is only 3.8% higher than the value calculated with a detailed infiltration program taking the internal partitions into consideration. The overall infiltration rate for the same house calculated as a shaft-type building is only 0.3% lower than the calculated rate for the story-type building (Table 4.5).

case	simplified model	detailed model	difference in %
1st floor, story-type	133	128	3.8
8th floor, story-type	185	183	1.1
total build., story-type	1205	1175	2.6
total build., shaft-type	1205	1172	2.8

#### 4.3.6 Other permeabilities - flow directions

What happens if one initially guess the wrong flow direction? Will this show up directly in a hand calculation? Suppose the leeward permeability in flat 3 is zero (with the same wind direction etc.), then we will have an airflow going from the windward side of flat 3 through the staircase, through flat 1 and flat 2 and out on the leeward side of flat 1 and flat 2. The leeward permeability for the staircase will increase during the iteration process. The resultant permeabilities are found using Equation 17.

No permeability on the leeward side of flat 3 is an extreme case, and it is obvious, that the flow then will go from the flat to the staircase. We often have situations with flow directions that are not obvious. For example, the permeability on the leeward side of flat 3 decreases from the initial value of 17.1, then at some point we will observe that the rpr-difference (rpr-value flat 3 minus rpr-value staircase) becomes negative. The airflow will then go in the other direction. The new flow directions are shown in Fig. 5.7.

A detailed study of this phenomena is presented in Table 4.6, where calculations with the simplified model are compared with those from the detailed model. All calculations with the simplified model are done with 5 iteration steps. Further studies have shown, that five iteration steps are sufficient after the change of air flow direction. If we are

mostly concerned about the overall flow for each flat, a calculation with 5 steps or less will be usually sufficient.

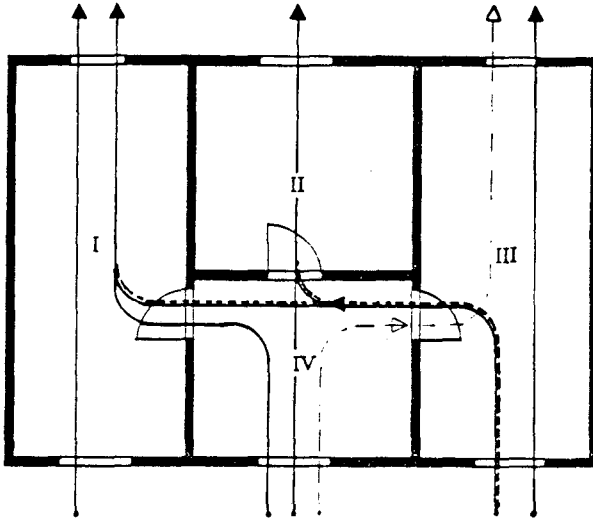

Fig. 5.7: Air flows - leeward permeability of flat 3  $< 12.0 [m^3/(hPa^n)]$

Table 4.6: Air mass flows - variable permeability $D_{lee}$ , flat 3 (1th floor) [kg/h], $v_a = 4 \text{ m/s}$ , $t_{out} = -10^\circ\text{C}$ , Wind perpendicular to facade, Story type building							
	wind	Flat 1 lee	door	Flat 2 door	wind	Flat 3 lee	door
<i>simplified</i>							
$D_{lee} = 18$	18.4	-40.5	22.1	44.5	76.2	-86.7	10.4
$= 13$	17.9	-41.5	23.6	45.9	67.0	-71.0	4.0
$= 12$	17.8	-41.7	24.0	46.3	64.4	-66.7	2.3
$= 11$	17.6	-42.0	24.4	46.7	61.8	-62.3	.5
$= 10$	17.5	-42.2	24.7	46.9	58.9	-57.7	-1.1
$= 9$	17.4	-42.5	25.1	47.3	55.9	-53.0	-2.9
$= 1$	15.4	-45.9	30.5	52.0	29.1	-9.8	-22.3
<i>detailed</i>							
$D_{lee} = 18$	18.5	-40.2	21.8	44.6	76.4	-85.2	8.8
$= 13$	17.7	-41.4	23.7	46.2	68.5	-68.5	0.1
$= 12$	17.5	-41.7	24.2	46.7	66.6	-64.0	-2.5
$= 11$	17.3	-42.0	24.7	47.1	64.4	-59.5	-4.9
$= 10$	17.1	-42.3	25.2	47.5	62.0	-54.9	-7.1
$= 9$	16.9	-42.6	25.7	47.9	59.5	-50.1	-9.4
$= 1$	15.5	-44.7	29.2	50.8	32.9	-6.3	-26.6

The most common reason for guessing the direction of a particular flow wrong, is lack of information on internal flow paths at the beginning of the iteration procedure. Usually, this occurs only in zones with opr-values lower than 0.5. The calculation procedure would then indicate the wrong directions after one or two steps.

Using the simplified model, Table 4.6 shows, that the air flow through the door of flat 3 changes direction at values for  $D_{lee}$  between 10 and 11. This corresponds to values between 12 and 13 if the detailed model is used. As the leeward permeability decreases, the air flows through the doors and leeward side of flat 2 and 3 increase.

#### 4.3.7 Wind parallel to facade

Until now we only have been handling wind perpendicular to the main facade (west). To show how to calculate air flows for wind flowing parallel to the main facade, the permeability distribution has been changed as indicated on Fig. 5.8. The permeability value for each of the three flats has been kept the same. The possible flow paths for a story type building is shown in Fig. 5.8.

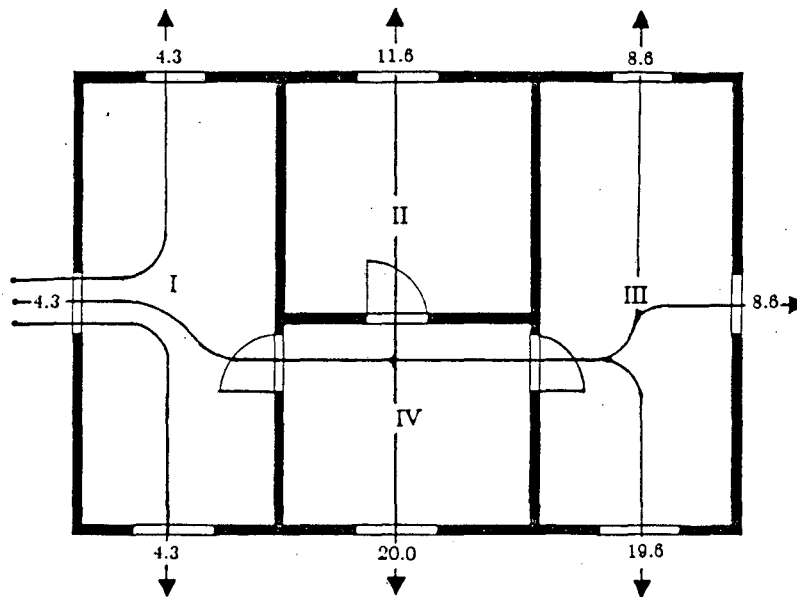

Fig. 5.8: Flow paths - wind parallel to the facade

The main problem is to find the resultant permeabilities for the flow paths going from flat 1 through the other zones. As we use the same  $c_{lee} = -0.3$  for all sides of the building except the windward side, this is a rather straight forward job:

- 1) - summarize the leeward permeabilities in zone III, and find  $D_{res,III}$  for  $D_{door,III}$  and  $\sum D_{lee,III}$ .

- 2) - find  $D_{res,II}$  for  $D_{door,II}$  and  $D_{lee,II}$ .
- 3) - summarize  $D_{res,III}$ ,  $D_{res,II}$  and  $D_{lee,IV}$ ; and find  $D_{res,II,III,IV}$  for  $D_{door,I}$  and  $\sum D_{res,II}, D_{res,III}, D_{res,IV}$ .
- 4) - split  $D_{wind,I}$  in relation to  $D_{res,II,III,IV}$ ,  $D_{lee,I,south}$  and  $D_{lee,I,north}$ .
- 5) - find  $D_{res}$  for the part of  $D_{wind,I}$  and the respective  $D_{lee,I,north}$ ,  $D_{lee,I,south}$  and  $D_{res,II,III,IV}$ .

This calculation does not involve an iteration procedure, so the correlation between the simplified and the detailed model for either wind or stack effect is good. But as in previous examples, the superimposition of different flows causes an error.

#### 4.4 Other Examples

Calculations are made for a series of different buildings ranging from a single family building to multistory buildings. The results from these calculations confirms the main results presented in detail for the Brunsbuettler building. But there is some differences regarding the modeling of air flows in different zones.

##### 4.4.1 Single family building

This house was chosen at random from a journal [8] presenting 275 new home designs. We consider this house to be a good example of a single family building in the U.S. The floor area is  $145 \text{ m}^2$  in the first floor and  $55 \text{ m}^2$  for the second floor. The first story with its great room, dining room, family room and kitchen is open to the staircase. Only the master bedroom and the utility/garage are separated by doors. There are no windows or doors on the short side walls of the building. The different permeabilities used in the calculations (see Fig. 7), are stipulated by using the ASHRAE Handbook of Fundamentals [2].

##### 4.4.1.1 Modeling

The main difference from the previous case is that both floors differ in size, design and permeabilities. Therefore,

- The zone including the staircase will include all rooms on the first floor except the master bedroom, utility room and garage. This "stair" zone has openings on both windward and leeward side at the first floor but, no openings on the second floor.
- The natural pressure level  $z_n$  is found using Equ. 22.
- Due to the lack of openings on the short sidewalls, there will be no air flows caused by wind parallel to the facade.



**FARMHOUSE FLAVOR IN AN ECONOMICAL HOME**

**PLAN NO. D10G8576** Once inside this home you'll be impressed with its warm cheery fireplace. From the great room you can gain access to the greenhouse and the spacious deck area. The master bedroom has its own fireplace, bath and huge walk-in closet. Upstairs are two more bedrooms and another full bath. Total living area: first floor 1454 sq ft., second floor 544 sq ft., and the greenhouse 125 sq ft.

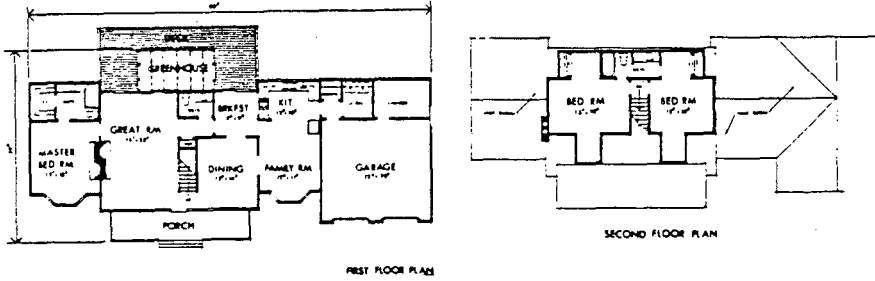

**Fig. 6:** Two-story single family building

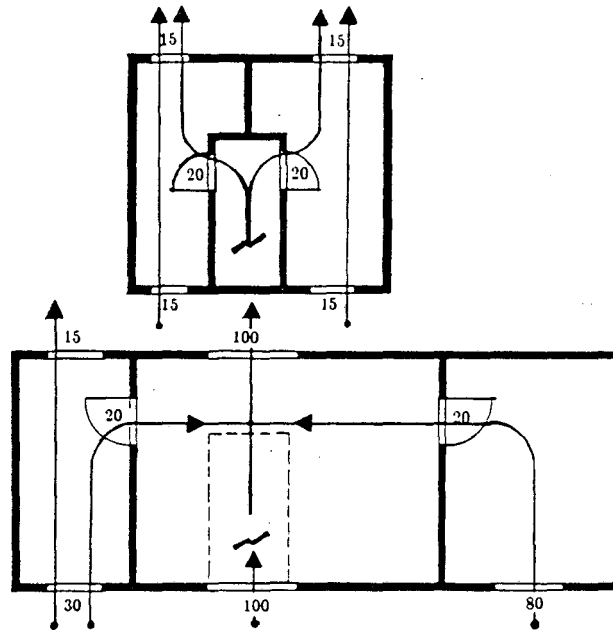

**Fig. 7:** Assumed flow paths - 1. iteration step

The building is divided in five zones; in the first floor the staircase together with living room, dining room and kitchen is one zone, master bedroom with the attached bath form one zone, and the and garage and utility room form another zone. In the second story, the stair is part of the staircase zone in the first floor, and each bedroom with bath forms another zone. As we assume uniform wind speed up to ten meters above the ground, there will be no downward airflow in the staircase due to wind effect (i.e. no difference between air flows for the story and the shaft type building). Possible flow paths

are shown in Fig. 7.

#### 4.4.1.2 Results - comments

The air mass flows due to wind and stack effect for  $v_o = 4$  m/s and  $t_{out} = -10$  °C and wind perpendicular to main facade are shown in Table 5.

Location	Simplified	Detailed	% difference
Zone 1 - Master bedroom			
windward	91.9	95.7	-4.0
lee	-82.0	-76.2	6.1
door	9.9	19.5	-10.0
Zone 2 - Living room			
windward	407.1	358.1	12.8
lee	-419.5	-383.0	9.5
door	12.4	24.9	-3.3
Zone 3 - Garage			
windward	66.6	63.6	4.7
lee	--	--	--
door	66.6	63.6	4.7
Zone 4 & 5 Bedroom			
windward	43.0	47.4	-5.8
lee	-83.8	-76.5	9.5
door	40.8	40.8	0.0

The differences are reasonable and well within acceptable limits. The results shown in Table 5 assume that the doors between the different zones are closed.

#### 4.4.2 Small multifamily building

This building is a three-story apartment building with a central fire wall built in Chicago in the 1920s [9]. The arrangement of apartments is similar to a lot of buildings from this period, with symmetrical floor plans having a common entry hall and a central stair in front, and separate balconies and outside stairs in back. The leakage areas were assumed to be evenly distributed for the different stories, and Fig. 9 shows the distribution of permeabilities and assumed flow paths.



Fig. 8: Three stories building, plan and elevation (Bosworth, Chicago)

#### 4.4.2.1 Modeling

The Bosworth building is not a simple square box; the front has oriel windows and the back of the building has closed balconies and outside stairs. Our models get rather complicated if we want to model all this in detail, so we have made the simplification shown in Fig. 9. The building is reduced to a square box; we use the same pressure coefficients for all leaks on one main sides. In the case with wind perpendicular to the street facade we assume a uniform wind pressure distribution over the whole facade. In order to compare the results of the two models, these simplifications were also done for calculations with the detailed model.

As described before the same permeabilities have been used for all floors. The leakage area between the two flats on each floor is taken into account, but not vertical leaks between flats on different floors. Due to identical permeabilities for the two flats on each floor, there will be the same pressures in flats on the same floor, both for stack effect and wind perpendicular to the facade. In one case of wind parallel to the main facade (from west), the pressures will be different in the two flats. This will cause an air flow directly from flat 1 to flat 2.



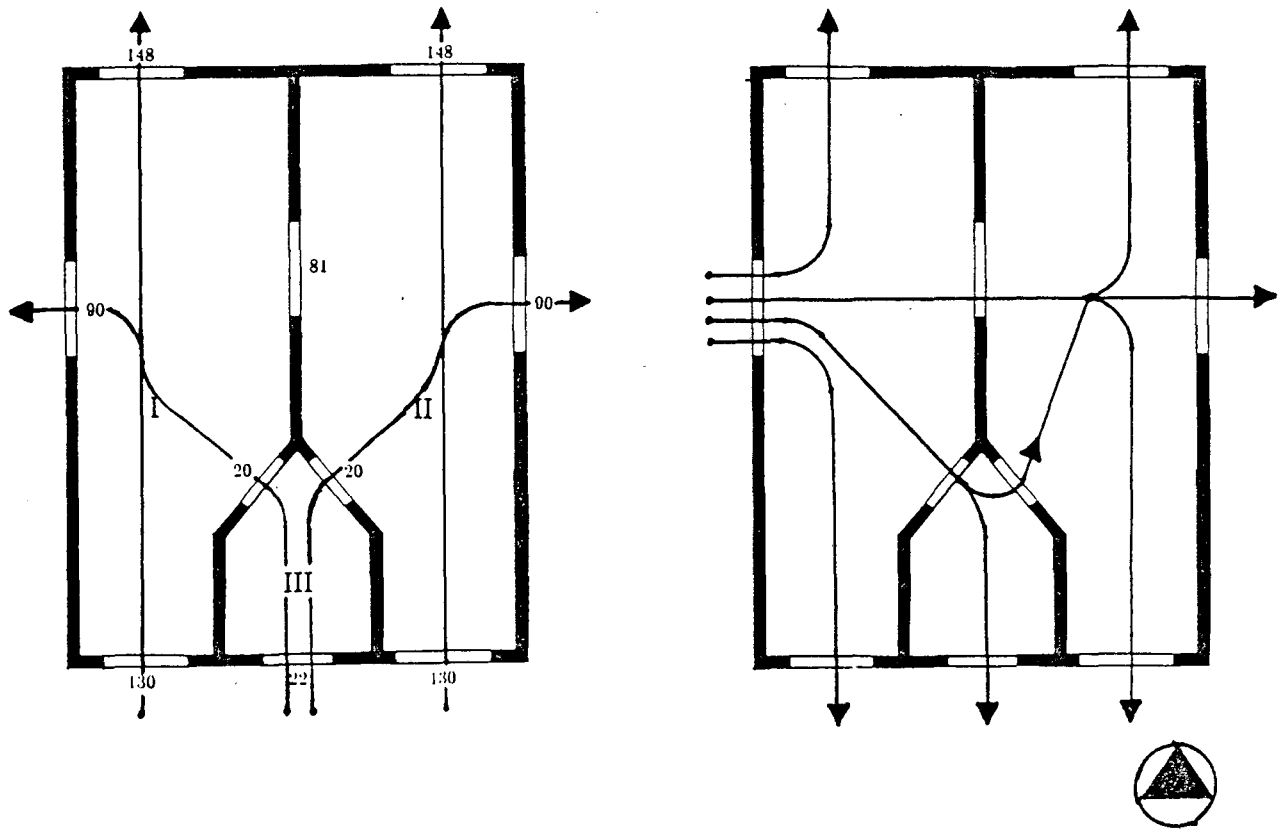

Fig. 9: Assumed flow paths for wind from south and west

#### 4.4.2.2 Results - comments

Table 6 shows air mass flows due to wind and stack effect for wind flows perpendicular to the main facade, whereas Table 7 shows air mass flows for wind parallel to the main facade. Total air mass flow due to wind and stack from the simplified and the detailed model as well as the differences between them, are presented in each table.

Table 6: Air mass flow due to wind and stack, $v_a=4m/s$ , $t_{out} = -10^\circ C$ , Wind perpendicular to facade				
Story	Lobby	Flat 1=Flat 2		
		Wind	Lee	Door
<i>Simplified</i>				
1	137.3	733.8	-674.0	-34.0
2	98.3	731.0	-681.2	49.1
3	48.7	728.2	-688.5	92.3
<i>Detailed</i>				
1	131.5	751.1	-736.3	-14.8
2	88.9	728.8	-782.2	53.4
3	35.9	732.7	-822.2	89.5
<i>Difference %</i>				
1	4.4	-2.3	-8.3	2.6
2	8.8	.3	-12.9	-0.5
3	7.2	-.4	-16.3	0.4

Table 7: Air mass flow due to wind and stack, $v_a=4m/s$ , $t_{out} = -10^\circ C$ , Wind parallel to facade							
Story	Lobby	Wind	Flat 1		Wall	Flat 2	
			Lee	Door		Lee	Door
<i>Simplified</i>							
1	63.8	601.0	-441.6	-77.2	118.7	-98.2	98.2
2	-13.6	599.2	-452.9	-26.4	118.7	-132.0	132.0
3	-71.1	597.4	-463.9	55.0	118.7	-161.9	161.9
<i>Detailed</i>							
1	70.1	619.6	-427.6	-70.5	121.5	-64.5	-57.1
2	-18.6	613.1	-463.0	-24.9	125.3	-138.7	-13.4
3	-75.7	615.8	-527.1	48.9	137.5	-203.5	66.0
<i>Difference %</i>							
1	-3.0	-3.0	2.3	1.1	-2.3	27.7	4.7
2	-9.0	-2.3	-1.7	0.2	-5.3	-4.8	0.5
3	-2.4	-3.0	-10.3	1.0	-13.7	-20.4	3.1

Tables 6 and 7 show that the flow directions are the same for all flows calculated either with the simplified or the detailed model. The high permeabilities for windows compared with those for the doors, makes the air flows through the flats more dominated by wind forces than the stack effect.

For wind perpendicular to the facade we find rather small differences between the models in mass flows going through the flats. The difference for the staircase is for the third floor 35.7%, but this is mainly caused by low mass flows in the staircase compared to mass flows through the flats. Assuming no adjacent buildings, the air mass flows through flat 2 are very low for wind from west (parallel to the main facade). This causes differences up 50%. Air flows coming in from the windward side of flat 1 (west) will mainly leave this zone through the leeward sides. Only a small air flow is transferred to the adjacent flat.

#### 4.5 Large multifamily buildings

The large apartment building contains 4 flats on each of the eight floors. We have studied different situations; a) the staircase has one wall with openings to the outside (called: open staircase), and b) the staircase has no exterior wall (closed staircase). Permeabilities for the different zones are shown on the respective simplified floor plans.

Compared to the building at Brunsbuettler Damm we have a building with openings to all 4 sides. For wind perpendicular to the main facade (from south), there are no main differences in the air flows between the two models. As the pressure coefficient is the same for all leeward sides, the parallel permeabilities can be added. Flow paths through flat 1 and 4 will either go directly from the windward to the leeward side (on west or east side) or from windward side to the stair and from there to the leeward side of the flats. Flows through flat 2 and 3 will always go from stair zone to leeward side. The flows for the leeward side of each zone are calculated separately, but are presented as the total leeward

flow for each zone in Table 8 and Table 9.

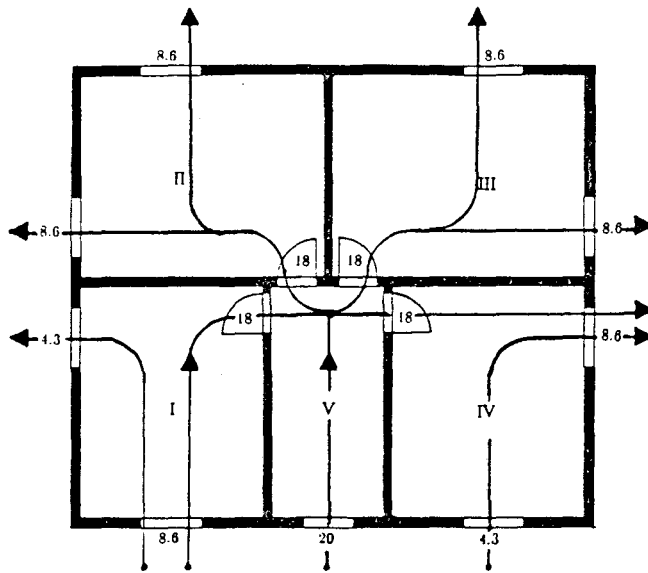

Fig. 10: Principal sketch - 4 flats / open staircase

**Table 8:** Air mass flow due to wind and stack, Wind perpendicular to facade,  $v_a = 4 \text{ m/s}$ ,  $t_{out} = -10^\circ\text{C}$ , Open staircase (Flat 2 and 3 similar)

Story	Lobby	Flat 1			Flat 2,3		Flat 4	
		Wind	Lee	Door	Lee	Wind	Lee	Door
<i>Simpl.</i>								
1	206.7	64.2	4.7	-75.8	65.5	36.0	25.4	-69.4
2	180.3	55.9	-8.3	-61.5	45.1	32.1	9.9	-54.4
3	151.9	46.9	-15.0	-45.4	18.0	28.0	-16.2	-36.8
4	121.7	37.3	-21.0	-25.1	-29.9	23.8	-30.8	-11.8
5	94.6	28.5	-28.9	16.4	60.4	21.0	-46.7	30.3
6	61.9	17.8	-35.6	40.5	83.9	17.7	-59.9	51.8
7	13.1	-2.0	-41.6	58.6	104.3	14.1	-71.9	69.3
8	74.2	-18.9	-47.1	74.2	122.6	9.7	-82.2	84.7
<i>Detal.</i>								
1	200	68	4	-72	50	37	21	-58
2	170	60	-7	-53	26	33	3	-36
3	138	51	-13	-38	-20	29	-18	-11
4	104	41	-19	-22	-46	23	-34	11
5	80	34	-26	-8	-66	20	-47	27
6	51	23	-32	9	-84	17	-58	41
7	-3	13	-38	25	-100	14	-68	54
8	-47	-1	-42	43	-116	11	-77	66

If the staircase has no direct permeabilities to the outdoor (Fig. 11), we will experience less pressure differences between the flats and the staircase, and therefore lower air flows. Table 9. gives the air flows for the same outdoor temperature and wind speed as shown in Table 8. The calculation does not include any flow resistance between the shaft and the floor landing.

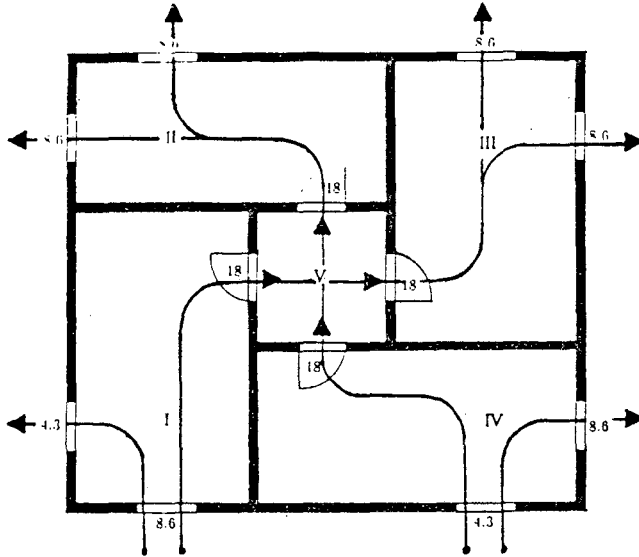

Fig. 11: Principal sketch - 4 flats / closed staircase

Table 9: Air mass flow due to wind and stack, Wind perpendicular to facade $v_w = 4 \text{ m/s}$ , $t_{out} = -10^\circ\text{C}$ , Closed staircase								
Story	Lobby	Wind	Flat 1		Flat 2,3 Lee	Wind	Flat 4	
			Lee	Door			Lee	Door
<i>Simplified</i>								
1	-	58.1	37.5	-70.3	73.4	49.0	35.6	-66.4
2	-	49.3	33.7	-55.3	54.4	39.3	31.6	-50.9
3	-	39.7	29.7	-38.0	31.2	28.3	27.4	-32.6
4	-	29.5	26.0	-15.6	-13.8	14.8	23.5	-5.1
5	-	21.5	25.0	20.4	-41.8	-7.9	21.9	28.3
6	-	11.0	23.7	39.4	-62.2	-21.9	20.1	46.2
7	-	-9.3	22.2	54.6	-79.6	-32.4	18.0	61.2
8	-	-20.8	20.4	68.0	-95.4	-41.4	15.6	74.6

For wind direction perpendicular to the main facade (from west), flat 1 and 2 will have a windward side, flat 3 and 4 together with the lobby will completely be on the leeward side.

## 5. SUMMARY

Buildings are classified into different categories based on their air permeability distribution. This is helpful in reducing the input data and limiting the different cases that might occur. For the simplification procedure we assume equal flow pattern for all permeabilities. Resultant permeabilities can be calculated for permeabilities in series and parallel arrangement. We can superimpose flows caused by different physical phenomena.

The examples show that the simplified method can be used to predict air mass flows within reasonable accuracy for different types of buildings. We are able to calculate air flows due to wind or stack effect within a few percent difference from results calculated with a detailed model. We might expect larger differences when superimposing flows caused by different effects. The best results are for superimposition of flows which have the same direction.

In all examples have we:

- 1) - calculated the flows for the story-type building
- 2) - calculated vertical flows due to wind
- 3) - calculated the flows due to thermal buoyancy
- 4) - superimposed the different flows

If the total air flow per zone is more important than the air flow for a particular flow path, the first few iteration steps already give a reasonable result. However, if the value for a particular flow path is important, the number of necessary steps is determined by the smallest rpr-differences.

In situations where the air flow direction is different from that assumed by using the opr-values, the share of the windward side permeability related to the resultant leeward permeability can be calculated by taking the leeward permeabilities of the considered zone and the rpr-value differences into account.

Iteration procedures are only necessary, if one can not calculate the rpr-differences for different zones immediately, and has to start using the opr-values. For the flows caused by stack effect and by vertical wind forces, the resultant permeabilities can be calculated for permeabilities in series and parallel arrangement directly. No iteration process is necessary.

Two important parameters -- the pressure field around the building and the permeability distribution of the external and internal building components -- are only roughly estimated. Both of these parameters must be determined for proper evaluation and application of models. With the growing proliferation of wind tunnel studies, it may soon be possible to predict the pressure field around a building. The need remains, however, for a multizone pressurization method capable of yielding necessary information about a building's air permeability distribution. Until both input parameters can be determined, all multizone infiltration models will be handicapped.

## 6. ACKNOWLEDGEMENTS

This work was supported by the Assistant Secretary for Conservation and Renewable Energy, Office of Building Energy Research and Development, Building Systems Division of the U.S. Department of Energy under Contract No. DE-AC03-76SF00098 and the Royal Norwegian Council for Scientific and Industrial Research under Contract No. BA7002.18414.

## 7. REFERENCES

- [1] Feustel, H.E. and Kendon, V.M.:  
Infiltration Models for Multicellular Structures - A Literature Survey  
Lawrence Berkeley Laboratory, Report No. LBL 17588, (1985).
- [2] Sherman, M.H.:  
Air Infiltration in Buildings  
Lawrence Berkeley Laboratory, Report No. LBL 10712, (1980).
- [3] Feustel, H.E. and M.H. Sherman:  
A simplified Model for predicting air flow in multizone structures"  
Lawrence Berkeley Laboratory, Report No. 22325, (1987)
- [4] Krischer, O. and Beck, H.:  
"Die Durchlueftung von Raeumen durch Windangriff und der  
Waermebedarf fuer die Lueftung"  
VDI-Berichte, Vol. 18, 1957, 29-59.
- [5] Deutsches Institut fuer Normung. DIN 4701:  
"Regeln fuer die Berechnung des Waermebedarfs von Gebaeuden"  
Beuth Vertrieb Berlin, (1983).
- [6] Feustel, H.E.:  
Development of a simplified multizone infiltration model.  
Lawrence Berkeley Laboratory, LBL-Report No. 19095, (1985)
- [7] ASHRAE Handbook of Fundamentals  
1985.
- [8] Harris Publications, Inc:  
"Best Value Home Plans"  
Volume 5 Number 2, (Summer 1986).
- [9] Diamond, R.C., Modera, M.P. and Feustel, H.E.;  
"Ventilation and Occupant Behaviour in Two Apartment Buildings"  
*Proceedings of the 7th AIVC Conference, Stratford, England (1986).*

**Appendix I:**  
 Resultant Permeability for two Permeabilities in Series Arrangement (Common Exponent = 2/3)

$D_{small}/D_{large}$	$D_{res}/D_{large}$	$D_{small}/D_{large}$	$D_{res}/D_{large}$	$D_{small}/D_{large}$	$D_{res}/D_{large}$
1.0000	0.6299	0.7336	0.5300	0.4672	0.3884
0.9946	0.6283	0.7283	0.5276	0.4619	0.3850
0.9893	0.6266	0.7229	0.5252	0.4565	0.3816
0.9840	0.6249	0.7176	0.5228	0.4512	0.3782
0.9787	0.6231	0.7123	0.5204	0.4459	0.3748
0.9733	0.6214	0.7069	0.5180	0.4406	0.3713
0.9680	0.6197	0.7016	0.5155	0.4352	0.3678
0.9627	0.6179	0.6963	0.5130	0.4299	0.3643
0.9574	0.6161	0.6910	0.5105	0.4246	0.3608
0.9520	0.6144	0.6856	0.5080	0.4192	0.3572
0.9467	0.6126	0.6803	0.5055	0.4139	0.3536
0.9414	0.6108	0.6750	0.5030	0.4086	0.3500
0.9360	0.6090	0.6697	0.5004	0.4033	0.3464
0.9307	0.6071	0.6643	0.4978	0.3979	0.3427
0.9254	0.6053	0.6590	0.4952	0.3926	0.3390
0.9201	0.6035	0.6537	0.4926	0.3873	0.3353
0.9147	0.6016	0.6483	0.4900	0.3820	0.3316
0.9094	0.5997	0.6430	0.4873	0.3766	0.3279
0.9041	0.5978	0.6377	0.4846	0.3713	0.3241
0.8987	0.5959	0.6324	0.4819	0.3660	0.3203
0.8934	0.5940	0.6270	0.4792	0.3606	0.3164
0.8881	0.5921	0.6217	0.4765	0.3553	0.3126
0.8828	0.5901	0.6164	0.4738	0.3500	0.3087
0.8774	0.5882	0.6110	0.4710	0.3447	0.3048
0.8721	0.5862	0.6057	0.4682	0.3393	0.3009
0.8668	0.5842	0.6004	0.4654	0.3340	0.2969
0.8615	0.5822	0.5951	0.4626	0.3287	0.2929
0.8561	0.5802	0.5897	0.4597	0.3233	0.2889
0.8508	0.5782	0.5844	0.4568	0.3180	0.2849
0.8455	0.5762	0.5791	0.4540	0.3127	0.2808
0.8401	0.5741	0.5738	0.4510	0.3074	0.2767
0.8348	0.5721	0.5684	0.4481	0.3020	0.2726
0.8295	0.5700	0.5631	0.4452	0.2967	0.2685
0.8242	0.5679	0.5578	0.4422	0.2914	0.2643
0.8188	0.5658	0.5524	0.4392	0.2861	0.2601
0.8135	0.5637	0.5471	0.4362	0.2807	0.2559
0.8082	0.5615	0.5418	0.4332	0.2754	0.2517
0.8028	0.5594	0.5365	0.4301	0.2701	0.2474
0.7975	0.5572	0.5311	0.4270	0.2647	0.2431
0.7922	0.5550	0.5258	0.4239	0.2594	0.2388
0.7869	0.5528	0.5205	0.4208	0.2541	0.2345
0.7815	0.5506	0.5151	0.4177	0.2488	0.2301
0.7762	0.5484	0.5098	0.4145	0.2434	0.2257
0.7709	0.5462	0.5045	0.4113	0.2381	0.2213
0.7656	0.5439	0.4992	0.4081	0.2328	0.2168
0.7602	0.5416	0.4938	0.4049	0.2274	0.2123
0.7549	0.5393	0.4885	0.4016	0.2221	0.2078
0.7496	0.5370	0.4832	0.3983	0.2168	0.2033
0.7442	0.5347	0.4779	0.3950	0.2115	0.1988
0.7389	0.5324	0.4725	0.3917	0.2061	0.1942

## Appendix II

Iteration step : #2

DESCRIPTION	#	FLAT # 1	FLAT # 2	FLAT # 3	STAIR (#4)
$D_{stair}$	1	6.0	10.6	3.5	---
$D_{door}$	2	18.	18.	18.	---
$D_{res:\#1,\#2}$	3	5.32	8.28	3.27	---
$D_{wind}$	4	4.3	---	19.6	20.
$D_{lee}$	5	8.6	11.6	17.1	10.35
$D_{lee, stair}$	6	4.78	11.6	2.44	---
$D_{res:\#2,\#6}$	7	4.37	8.79	2.36	---
$D_{res:\#3,\#6}$	8	---	---	---	---
$D_{res:\#4,(\#5-\#6)}$	9	---	---	---	---
$rpr \frac{\#5}{\#3+\#4+\#5}$	10	0.52	0.68	0.44	0.34
rpr-difference	11	0.18	0.34	0.10	---
share of $D_{stair}$	12	5.8	11.0	3.3	---

Iteration step : #3

DESCRIPTION	#	FLAT # 1	FLAT # 2	FLAT # 3	STAIR (#4)
$D_{stair}$	1	5.8	11.0	3.2	---
$D_{door}$	2	18.	18.	18.	---
$D_{res:\#1,\#2}$	3	5.19	8.48	3.05	---
$D_{wind}$	4	4.3	---	19.6	20.
$D_{lee}$	5	8.6	11.6	17.1	11.5
$D_{lee, stair}$	6	4.7	11.6	2.3	---
$D_{res:\#2,\#6}$	7	4.3	8.79	2.3	---
$D_{res:\#3,\#6}$	8	3.1	6.1	1.7	---
$D_{res:\#4,(\#5-\#6)}$	9	2.6	---	10.6	---
$rpr \frac{\#5}{\#3+\#4+\#5}$	10	0.51	0.65	0.44	0.37
rpr-difference	11	0.14	0.28	0.07	---
share of $D_{stair}$	12	5.7	11.4	2.9	---



*LAWRENCE BERKELEY LABORATORY  
TECHNICAL INFORMATION DEPARTMENT  
UNIVERSITY OF CALIFORNIA  
BERKELEY, CALIFORNIA 94720*