

Lawrence Berkeley National Laboratory

LBL Publications

Title

Advanced Light Source Master Oscillator

Permalink

<https://escholarship.org/uc/item/61s9r5fb>

Authors

Lo, C C

Taylor, B

Baptiste, K

Publication Date

1989-03-01



Lawrence Berkeley Laboratory

UNIVERSITY OF CALIFORNIA

Accelerator & Fusion Research Division

Presented at the 1989 IEEE Particle Accelerator Conference,
Chicago, IL, March 20-23, 1989, and to be published in
the Proceedings

Advanced Light Source Master Oscillator

C.C. Lo, B. Taylor, and K. Baptiste

March 1989

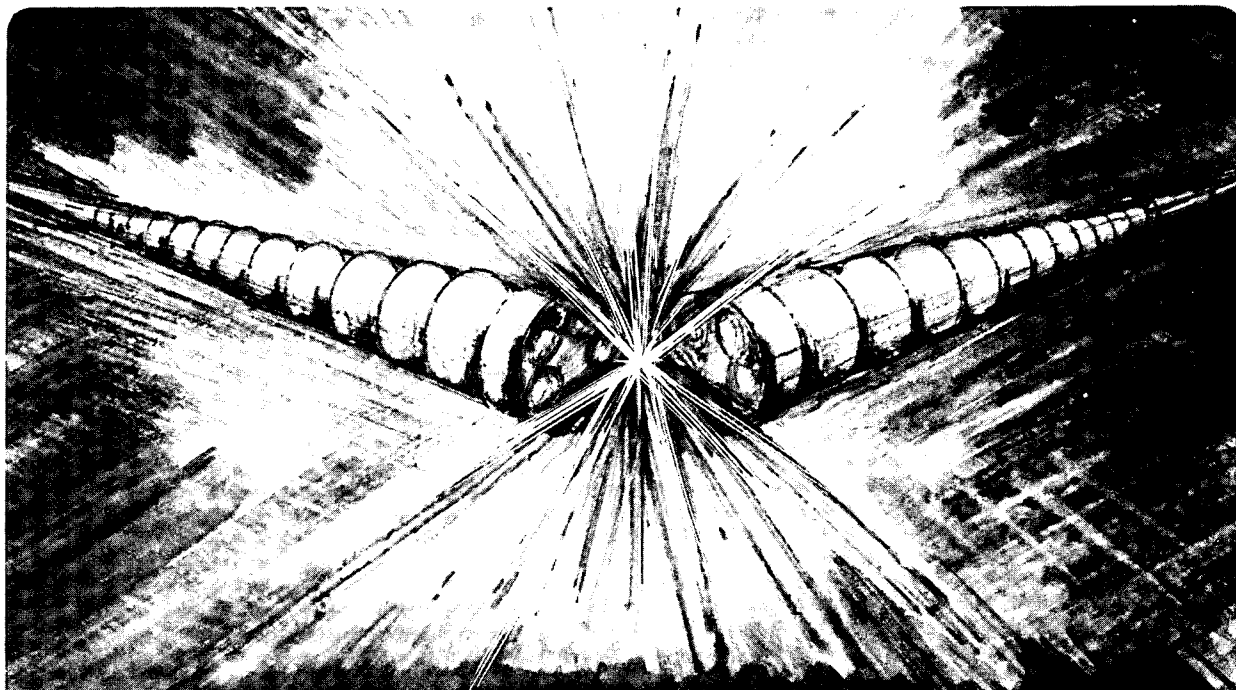

1 LOAN COPY 1
1 CIRCULATES 1
1 FOR 2 WEEKS 1

Bldg. 50 Library.
COPY 2

LBL-25974

DISCLAIMER

This document was prepared as an account of work sponsored by the United States Government. While this document is believed to contain correct information, neither the United States Government nor any agency thereof, nor the Regents of the University of California, nor any of their employees, makes any warranty, express or implied, or assumes any legal responsibility for the accuracy, completeness, or usefulness of any information, apparatus, product, or process disclosed, or represents that its use would not infringe privately owned rights. Reference herein to any specific commercial product, process, or service by its trade name, trademark, manufacturer, or otherwise, does not necessarily constitute or imply its endorsement, recommendation, or favoring by the United States Government or any agency thereof, or the Regents of the University of California. The views and opinions of authors expressed herein do not necessarily state or reflect those of the United States Government or any agency thereof or the Regents of the University of California.

C.C. Lo, B. Taylor and K. Baptiste

Lawrence Berkeley Laboratory
University of California
Berkeley, California 94720 U.S.A.

ABSTRACT

The Master Oscillator of the Advanced Light Source operates at a frequency of 499.654 MHz which is the 328th harmonic of the storage ring. The oscillator is capable of providing up to a maximum of ± 500 KHz frequency deviation for various experimental purposes. Provisions for external signal injection as well as using an external signal source have been designed into the unit. A power distribution system has also been included to provide signals for various parts of the ALS machine and user requirements. The Master Oscillator is made up with modules housed in a Euro chassis.

INTRODUCTION

The Master Oscillator of the Advanced Light Source provides the heart beat of all RF and timing devices for the entire machine. It also provides the synchronous signals required for time resolved experiments. The signal outputs also provide drive for the electron gun pulsing system, the linac subharmonic bunchers(1), the S band buncher, the S Band Accelerator Guides(2) and the Rf cavities of the booster and storage ring(3). The signal of the oscillator is also amplified and distributed to various parts of the machine via distribution amplifiers which will be covered at a later part of this report.

Although frequency accuracy and stability are some of the most important characteristics of the oscillator, frequency flexibility is a useful feature to facilitate various physics investigations. As a last resort small frequency changes of the oscillator could be used to correct mean tolerance errors in the storage ring circumference. The ring radius is related to the master oscillator frequency by the following expression:

$$R = (nc)/(2\pi Fc)$$

where n = harmonic number
c = speed of light
Fc = oscillator center frequency

it follows that

$$\Delta R = (nc/2\pi) \times [(Fc - Fd)/(FcFd)]$$

where ΔR = incremental change of the Storage Ring radius.

Fd = deviated oscillator frequency

For a change of ± 100 KHz in frequency the Ring radius could change an amount of ± 0.626 cm with Fc being 500 MHz. With a frequency deviation of ± 500 KHz the ring radius correspondingly could change an amount of ± 3.129 cm. However the extremes of this range could render the RF cavities out of normal operating range. The most critical component however are the Linac Accelerator Guides whose sole frequency tuning control is via the temperature of the water system.

SYSTEM ORGANIZATION

Figure 1 shows the block diagram of the Master Oscillator. There are two independent crystal oscillators in the system. One is a Temperature Compensated Crystal Oscillator (TCXO); the other one is an Oven Controlled Linear Voltage Controlled Crystal Oscillator (OC/VCXO). The two oscillators serve as two of the three alternative signal sources; the other being an optional external signal source. The option of injecting an external signal to mix with the Voltage Controlled Oscillator is provided via the 10 dB directional coupler in the signal path between the OC/VCXO and the signal source selection switch. The output signal from the switch is then amplified and fanned out for driving up to nine signal distribution amplifiers whose outputs are used for the Linac RF system, the Booster and Storage Ring RF systems as well as other instrumentation and experimental needs. The RF signal and states of operations of the Master Oscillator are monitored by the ALS Control System via the Intelligent Local Controller (ILC)(4). Frequency sweep control is either local or by the ALS Control System through the ILC.

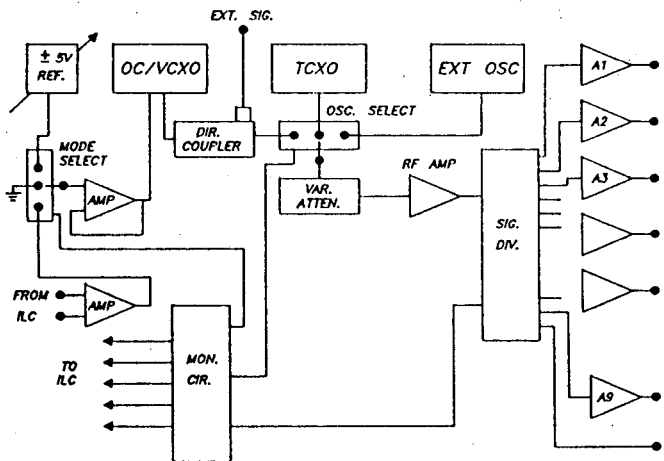

Fig. 1 Block diagram of the Master Oscillator

THE OSCILLATORS

The normal operating signal frequency is provided by the Temperature Controlled Crystal Oscillator (TCXO) whose center frequency can be adjusted mechanically through a range of approximately ±5KHz. However if the oscillator has to operate at either extreme ends one may lose the ability of long term aging compensation. Hence if the operating center frequency has to be changed by more than a few KHz, another TCXO with the proper center frequency should be used. The mechanical adjustment resolution is approximately 50 Hz. The stability of the TCXO is specified at ± 2x10⁻⁷ through the temperature range of 0 - 50°C. Aging and phase noise are specified at 1x10⁻⁸ per day and -112 dBc/Hz at 1 KHz offset respectively.

The Oven Controlled Linear Voltage Controlled Crystal Oscillator (OC/VCXO) is used to provide a signal with much larger frequency range. The frequency adjustment is made by $\pm 5V$ control voltage. This voltage is either provided by a local stable voltage source which has a temperature coefficient of 5ppm per $^{\circ}C$ or via the Intelligent Local Controller which provides a control voltage through a 14 bit DAC with $\pm 10V$ output. This translates into a resolution of 61 Hz/bit. The maximum range of frequency adjustment is ± 500 KHz. The present circuit only allows ± 100 KHz adjustment with the same 61 Hz/bit resolution. The full 1 MHz range can be implemented by changing a voltage divider at the output of the stable voltage source and the gain of the differential amplifier which accepts the DAC voltage from the ILC. Figure 2 is a plot of the output frequency variation of the OC/VCXO as a function of control voltage. The stability of the OC/VCXO is specified at ± 1.5 KHz through the temperature range of 0 - 50 $^{\circ}C$. The phase noise is specified at -85 dBc/Hz at 1 KHz offset.

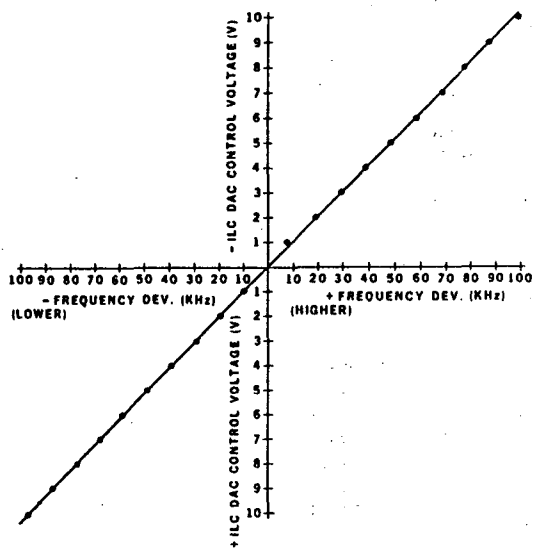

Fig. 2 Output frequency variation of the VCXO as a function of control voltage

It is noteworthy to mention at this point that the dc supplies for both the TCXO and the OC/VCXO oscillators should be low noise power sources. Linear dc power supplies are preferred to switching supplies which normally operate in the frequency range of 20KHz to 120 KHz. The fundamental and harmonics of these frequencies may fall close to the Synchrotron and orbit frequencies of particle accelerators. Sidebands of these frequencies even at low level could generate significant voltages in RF cavities. Experience has shown that these spurious voltages can cause instabilities in accelerators. Often the only evidence is a degradation of beam lifetime. These interfering sidebands, if present, should be at least 55 dB below the operating center frequencies of accelerators.

THE SIGNAL DISTRIBUTION AMPLIFIERS

The RF signal distribution amplifiers are constructed with Motorola's MHW709-3 thin film hybrid amplifier modules which are capable of producing over 10 watts of power with a maximum operating frequency of 512 MHz. The amplifiers are operated on 12.5V DC and prefer a drive power of not less than 21 dBm. The gain is adjustable by varying the voltage supply (V_c) to the first stage. Figure 3 shows a typical

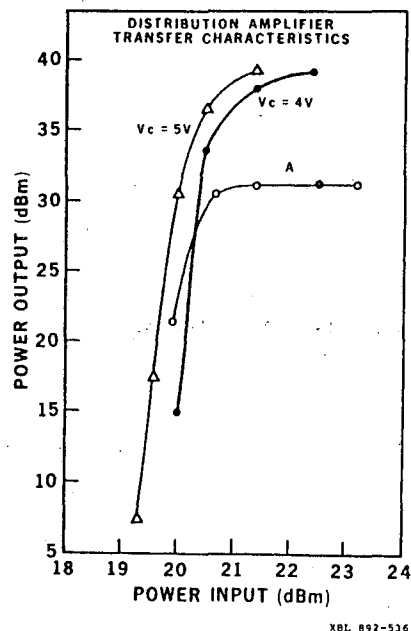

Fig. 3 Power transfer functions of the signal distribution amplifier

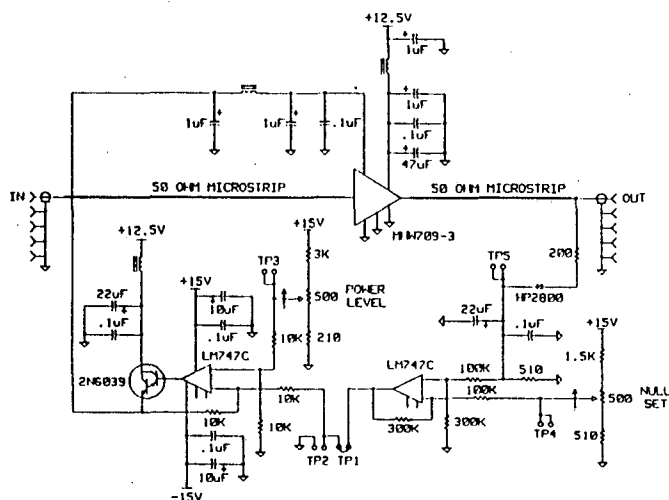

Fig. 4 Schematic diagram of the signal distribution amplifier

amplifier's power transfer functions. To prevent excessive power output excursions an automatic level control (ALC) loop is included to hold the output power level constant despite of changes in ambient temperature and input power level. Curve A in Fig. 3 shows the transfer function with the ALC loop in operation. Figure 4 is a schematic diagram of the signal distribution amplifier. The amplifier module is bolted to a block of copper which in turn is bolted to the case of the amplifier metal housing for heat dissipation purpose. Figure 5 is the output spectrum of an amplifier with an input drive of 21 dBm and producing an output of 33 dBm. Figure 6 shows the sidebands in the output spectrum of the master oscillator with an external 100 KHz signal injected through the 10 dB directional coupler.

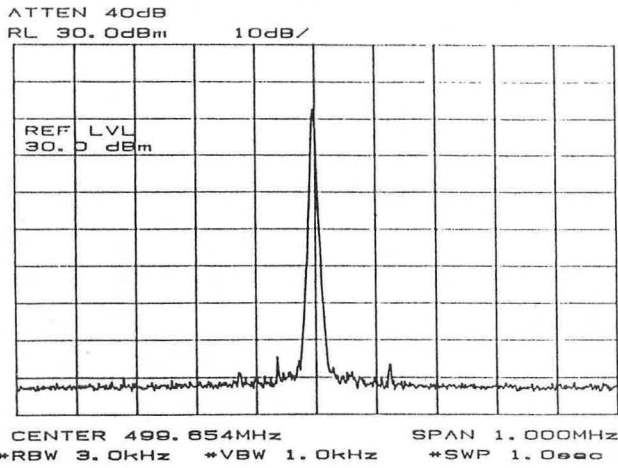

Fig. 5 Typical signal output spectrum of the Master Oscillator

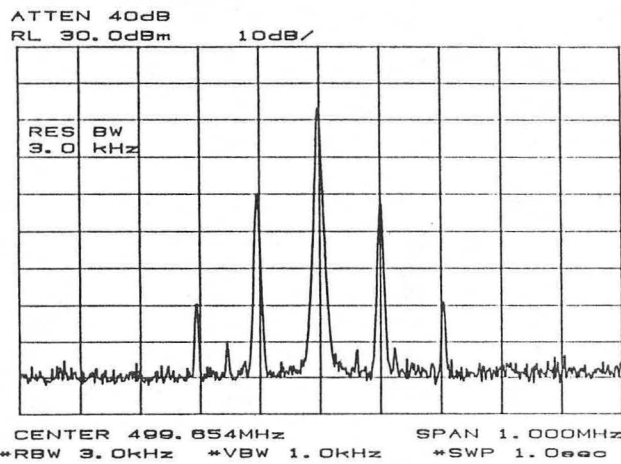
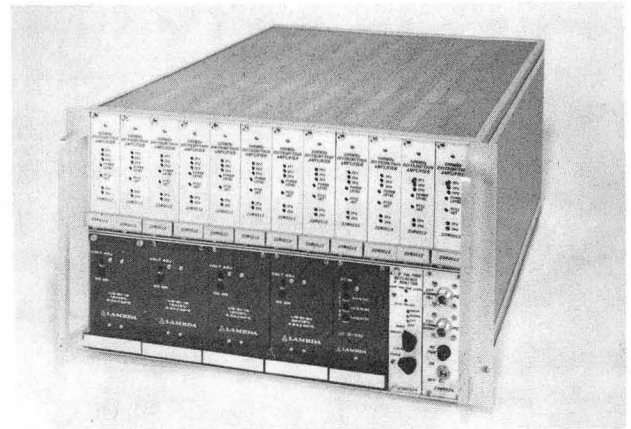

Fig. 6 Typical signal output spectrum of the Master Oscillator with a 100 KHz external signal injection

SYSTEM PACKAGING

The modular construction concept was used through out the Master Oscillator. A 19" x 10.5" x 21" Euro chassis was used for housing all the different modules. Figure 7 is a photograph of the Master Oscillator. The power supplies are located in the bottom row with the exceptions of the two right most modules which are the general control units. The distribution amplifiers are located on the upper row. The RF amplifiers, oscillators, the directional coupler and power splitters are mounted on two pedestals located in the rear part of the chassis. Outputs of the amplifiers and power divider are all located in the rear panel. External signal source and external signal injection inputs are located in the front panel of one of the two general control modules in the lower front row.



CBB892-1290

Fig. 7 Photograph of the Master Oscillator

CONCLUSIONS

The design, performance and construction of the ALS Master Oscillator have been presented. We believe that adequate flexibilities have been designed into the system for the start up and tune up of ALS. The modular design enables future operating requirements to be implemented should it be necessary.

ACKNOWLEDGMENTS

This work was funded by the Director, Office of Energy Research, Office of Basic Energy Sciences, Material Science Division of the U.S. Department of Energy under Contract No. DE-AC03-76SF00098 with Lawrence Berkeley Laboratory. Reference to a company or a product name does not imply approval or recommendation of the product by the University of California or the U.S. Department of Energy to the exclusion of others that may be suitable.

REFERENCES

1. C.C. Lo, B. Taylor, H. Lancaster and J. Guigli, Advanced Light Source Linac Subharmonic Buncher Cavities. To be presented in this conference.
2. B. Taylor, H. Lancaster and H. Hoag, Engineering Design Of The Injector Linac For The Advanced Light Source (ALS). Presented at the Linear Accelerator Conference, Oct. 3-7, 1988.
3. B. Taylor, K. Baptiste, H. Lancaster and C.C. Lo, Advanced Light Source Storage Ring RF System. To be presented in this conference.
4. S. Magyary et al, Advanced Light Source Control System. To be presented in this conference.

LAWRENCE BERKELEY LABORATORY
TECHNICAL INFORMATION DEPARTMENT
1 CYCLOTRON ROAD
BERKELEY, CALIFORNIA 94720