

Lawrence Berkeley National Laboratory

Lawrence Berkeley National Laboratory

Title

Bio-Organic Chemistry Quarterly Report

Permalink

<https://escholarship.org/uc/item/67r5v45d>

Author

Various

Publication Date

1961-10-17

00101703377

UCRL 9900

UNIVERSITY OF
CALIFORNIA

Ernest O. Lawrence

*Radiation
Laboratory*

BIO-ORGANIC CHEMISTRY QUARTERLY REPORT
June through August 1961

TWO-WEEK LOAN COPY

**This is a Library Circulating Copy
which may be borrowed for two weeks.
For a personal retention copy, call
Tech. Info. Division, Ext. 5545**

U 0 1 0 1 / 0 0 0 0 0

Research and Development

UCRL-9900
UC-4 Chemistry
TID-4500 (16th Ed.)

UNIVERSITY OF CALIFORNIA
Lawrence Radiation Laboratory
Berkeley, California
Contract No. W-7405-eng-48

BIO-ORGANIC CHEMISTRY QUARTERLY REPORT
June through August 1961
October 17, 1961

BIO-ORGANIC CHEMISTRY QUARTERLY REPORT

June through August 1961

Contents

1.	Absorption Spectra of Spinach Chloroplast Fragments and the Stability of the Pigments (Sauer)	1
2.	Photosynthetic and ESR Behavior of a <u>Chlamydomonas reinhardi</u> Mutant During Chlorophyll Synthesis (Androes, Biggins, and Singleton)	12
3.	ESR Studies of Chromatophores From <u>Rhodospirillum rubrum</u> (Androes and Singleton)	17
4.	A Study of Light-Catalyzed Oxygen Transport in Photosynthesis. Part I (Shneour)	21
5.	A Study of Light-Catalyzed Hydrogen Transport Under Photosynthetic Condition. Part II. (Shneour)	26
6.	Further Studies on the Formation of Methylphosphate by Treatment of $P^{32}O_4$ -Fed Spinach Chloroplasts with Methanol (Ullrich)	30
7.	The Nucleic Acid Content of <u>Spinacea oleracea</u> Chloroplasts (Biggins and Park)	39
8.	Paper Chromatography of Nucleic Acid Constituents (Ponnampereuma)	45
9.	Primordial Organic Chemistry: Evidence for Production of Purines and Pyrimidines From Simple Gases by Electron Irradiation (Palm and Calvin)	51
10.	Electron Irradiation of Aqueous Solutions of HCN (Palm and Calvin)	65
11.	Radiation Chemistry of Crystalline Choline Chloride (Smith and Lemmon)	72
12.	The Radiation Decomposition of Guanine (Ponnampereuma and Lemmon)	80
13.	Formamido Pyrimidines from Adenine (Ponnampereuma and Lemmon)	81
14.	Complexes of Sulfur Acids with Electron Acceptors (Hammond)	84
15.	The Diethyl Phosphonate-Trinitrobenzene Complex (Hammond)	86

*Preceding Quarterly Reports: UCRL-9772, UCRL-9652

BIO-ORGANIC CHEMISTRY QUARTERLY REPORT

June through August 1961

M. Calvin, Director

Lawrence Radiation Laboratory and Department of Chemistry

University of California, Berkeley, California

October 17, 1961

1. ABSORPTION SPECTRA OF SPINACH CHLOROPLAST FRAGMENTS
AND THE STABILITY OF THE PIGMENTS

Kenneth Sauer*

Absorption spectra whose shape can be attributed solely to the nature of the pigments present have been obtained for spinach chloroplast fragments. The measurements were made in a standard recording spectrophotometer without the use of opal glass, integrating spheres, or other special devices, and without requiring adjustment of the refractive index of the suspending medium.

The procedure described by Park and Pon¹ for the sonic rupture of spinach chloroplasts, followed by differential centrifugation of the fragments, produces suspensions which exhibit negligible light scattering. Furthermore, the pigment molecules present in these fragments give evidence of being in their *in vivo* environment. The studies by Rabideau, French, and Holt² showed that the sonic treatment of chloroplasts does not shift the pigment absorption band maxima from their positions *in vivo*. The present study confirms this observation and extends it to include much smaller particles than those studied previously. Furthermore, the isolated fragments of the pigmented chloroplast lamellae retain a high activity for the evolution of oxygen by the Hill reaction using potassium ferricyanide and ferric oxalate³ or 2,6-dichlorophenolindophenol⁴ and are capable of carbon dioxide fixation when the supernatant liquid from the ultracentrifugation is present as well.¹ The separated lamellae fragments also show electric birefringence (Kerr effect) and electric dichroism,⁵ the latter in particular arguing for some degree of orientation of the pigment molecules with respect to one another.

* U. S. Public Health Service Fellow, 1960-1962.

1. R. B. Park and N. G. Pon, *J. Mol. Biol.* 3, 1 (1961).
2. G. S. Rabideau, C. S. French, and A. S. Holt, *Am. J. Botany* 33, 769 (1946).
3. C. S. French, A. S. Holt, R. Powell, and M. L. Anson, *Science* 103, 505 (1946).
4. Roderic B. Park and Ulrich Heber (Lawrence Radiation Laboratory), private communication.
5. Kenneth Sauer (Lawrence Radiation Laboratory), unpublished results.

Experimental Procedure

Chloroplast lamellae fragments were prepared essentially by the procedure of Park and Pon.¹ In brief, chloroplasts isolated from the homogenate of spinach leaves were sonically ruptured at 9 kc/sec for 90 sec. The sonicated suspension was centrifuged at 35,000 g (maximum value) for 10 minutes, and the precipitate, containing the largest pieces, was discarded. The supernatant was then centrifuged at 145,000 g for 20 minutes, giving rise to a supernatant containing "small fragments" and a precipitate containing "large fragments." The latter was resuspended in water or buffer (as noted in the text), was sonicated a second time, and then recentrifuged to give a suspension of small fragments relatively free of fraction-1 protein (carboxydismutase) and other small molecules. All operations were carried out at or near 0°C, as far as possible. The three types of preparations studied will be referred to as small fragments, large fragments, and twice-sonicated fragments, respectively.

Spectra were recorded on a Cary Model 11 or Model 14 spectrophotometer. The samples were contained in matched 1-cm quartz cuvettes. Appropriate base-line corrections were made in order that an accurate representation of the scattering of the samples be indicated by the spectra shown in the accompanying figures.

Absorption Spectra

A typical spectrum of sonicated chloroplast fragments is shown in Fig. 1, along with the spectrum of an acetone extract from these fragments. Casual inspection of the spectrum of the fragment suspension indicates that the sample exhibits very little turbidity (light scattering). The best quantitative measure of turbidity is the ratio of the apparent absorbency in the far red beyond 735 m μ to the absorbency of the red maximum at 678 m μ . In this work this ratio is less than 0.01. Rabinowitch⁶ also considers the ratio of absorbency at the minimum in the green (at 555 m μ here) to that of the red maximum as a measure of scattering, and reports the ratio of the absorbency in the violet (at 437 m μ here) to that at the red maximum as constituting a significant ratio in the spectra. A summary of these ratios for the best spectra of chloroplasts and *Chlorella* published to date is given in Table I. It is interesting to note that the use of an opalescent plate diffuser,⁷ although it greatly sharpens the spectra of strongly scattering samples, still gives a relatively high apparent absorbency in the far red. The two spectra noted in Table I that have been previously reported to give the lowest scattering in the far red have other limitations associated with them. In the first case, the suspension of pigment-protein complex clarified by digitonin studied by Smith¹⁰ gives a spectrum which is appreciably distorted and shifted from that of the unclarified

6. E. I. Rabinowitch, *Photosynthesis*, vol. II, part I (Interscience Publishers, Inc., New York, 1951).

7. K. Shibata, A. A. Benson, and M. Calvin, *Biochim. Biophys. Acta* 15, 461 (1954).

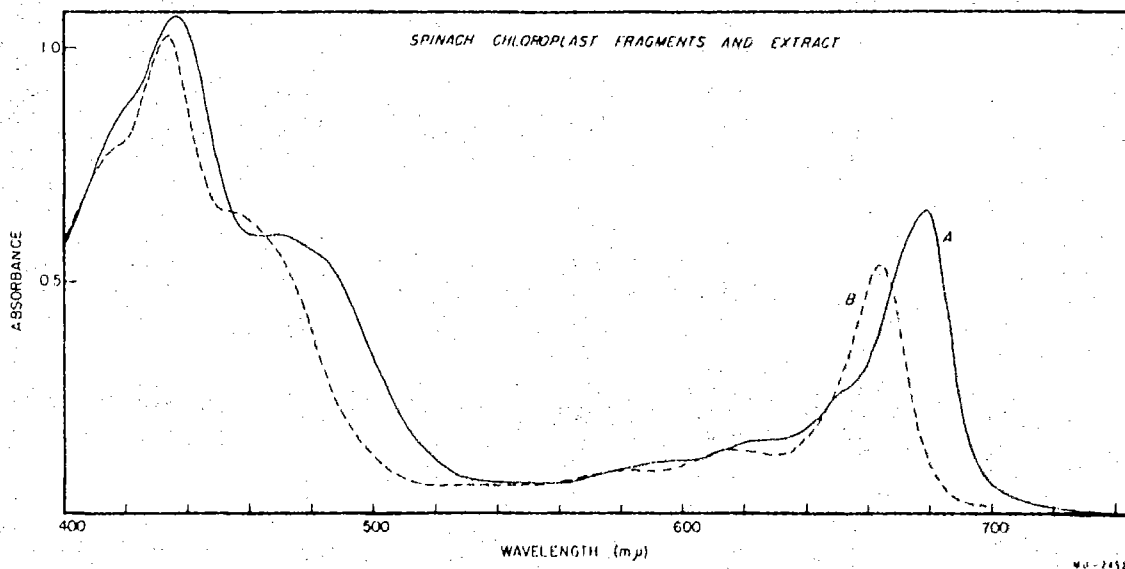

Fig. 1. Absorption spectrum of a spinach chloroplast fragment suspension and extract: A (solid curve), suspension of twice-sonicated fragments in 10^{-2} M aqueous phosphate buffer, pH 7.4, freshly prepared; B (dashed curve), acetone extract from sonicated fragments, freshly prepared -- spectrum furnished by Roderic B. Park.

Table I. Absorbance ratios for chloroplast pigments in aqueous spinach and *Chlorella* suspensions.

(Absorbencies at the violet maximum, the green minimum, the red maximum, and in the far red beyond 720 m μ)

System	Method	Reference	A(green)	A(violet)	A(far red)
			A(red)	A(red)	A(red)
<i>Chlorella</i> (+ protein)	Transmission (refractive index adjusted)	8. Barer (1955)	0.59	1.36	0.4
<i>Chlorella</i>	Transmission	9. Emerson, Lewis (1941)	0.28	1.40	0.2
<i>Chlorella</i>	Opalescent plate	7. Shibata, Benson, Calvin (1954)	0.24	1.33	0.17
Spinach (protein-pigment suspension)	Transmission	10. Smith (1941)	0.254	1.62	1.10
Spinach (protein-pigment suspension with digitonin)	Transmission	10. Smith (1941)	0.132	1.60	0.034
Spinach sonicate	Transmission	2. Rabideau, French, Holt (1946)	0.28	1.90	0.086
Spinach sonicate	Integrating sphere	2. Rabideau, French, Holt (1946)	0.18	1.14	Small (<0.03)
Spinach sonicate (lamellae fragments only)	Transmission	This study	0.103 \pm .005	1.63 \pm .02	<0.01

8. R. Barer, *Science* 121, 709 (1955).

9. R. Emerson and C. M. Lewis, Gibson Island A. A. A. S. Symposium on Photosynthesis (unpublished); see Reference 6, p. 708.

10. E. L. Smith, *J. Gen. Physiol* 24, 565 (1941).

suspension, and the system is criticized by the author as not representing the true pigment spectrum of the *in vivo* system. In the second case, the measurement by Rabideau, French, and Holt⁴ on sonicated material by use of an integrating sphere detector is more truly representative of the *in vivo* situation. The instrument used, however, suffers from rather limited spectral resolution and is not a device that is readily available to most laboratories. The study reported herein yields the lowest relative values for absorbency in the far red or at the green minimum thus far reported, with the exception of pigment extracts in organic solvents. The ultracentrifugation at higher accelerations has clearly produced suspensions of much smaller particles than those obtained earlier by Rabideau, French, and Holt. The supernatant liquid resulting from centrifugation of the chloroplast sonicate at 145,000 g has been examined with the electron microscope¹ and appears to consist of particles containing 1 to 10 of the oblate spheres mentioned by Park and Pon¹ as constituting units of the chloroplast lamellar structures. The particles in the solution of small fragments studied here will then be sheets 100 Å thick and 200 to 1,000 Å in diameter. The large fragments will average somewhat greater in diameter, but not as large as 10,000 Å, which particles Park and Pon have shown to be precipitated between 5,000 and 10,000 g. Thus, the particles studied are seen to be comparable to or less than the wave length of light used in the measurements, and little turbidity is to be expected in the resulting suspensions.

The maximum of the red absorption band for the spectrum of the fragments shown in Fig. 1 occurs at 678.51.5 m μ . This is in excellent agreement with the value of 678.2 m μ given by Rabideau, French, and Holt⁴ for the larger fragments they studied and in general for the *in vivo* spectra summarized by Rabinowitch.⁶ In some cases in the study presented here values as high as 680.5 m μ were obtained from different spinach samples freshly prepared. The wave length of the maximum was, however, independent of the particle size for the preparations studied from a single sample of spinach. The acetone extract has its corresponding maximum at 663 m μ . Also observable in the spectrum of the fragments in Fig. 1 are pronounced shoulders at about 650, 625, and 590 m μ . The maximum in the blue occurs in the range 436 to 438 m μ , depending on the sample, and shoulders are evident at 415, 470, and 485 m μ . Further discussions of some of these features are included among the observed effects of aging the samples.

It is believed that the spectra reported here, as typified in Fig. 1, are appreciably better than any previously reported for higher plant material essentially in its *in vivo* environment.

Aging and Bleaching

Samples of chloroplast lamellar fragments prepared at or near 0°C by the procedure of Park and Pon were then stored in air at 2°C for periods of up to 2 weeks or more. Figure 2 shows spectra, taken at intervals, of separate portions of a single suspension of twice-sonicated fragments kept in the dark at 2°C. During the first two days there is no measurable change (less than 0.5%) in absorbency at 678.5 m μ , indicating that no significant bleaching (oxidation) of chlorophylla occurs during this interval. The recorded spectra of the fresh and of the 2-day-old samples were absolutely superimposed from 500 to 750 m μ . Below 500 m μ , however, the absorbency is seen to have

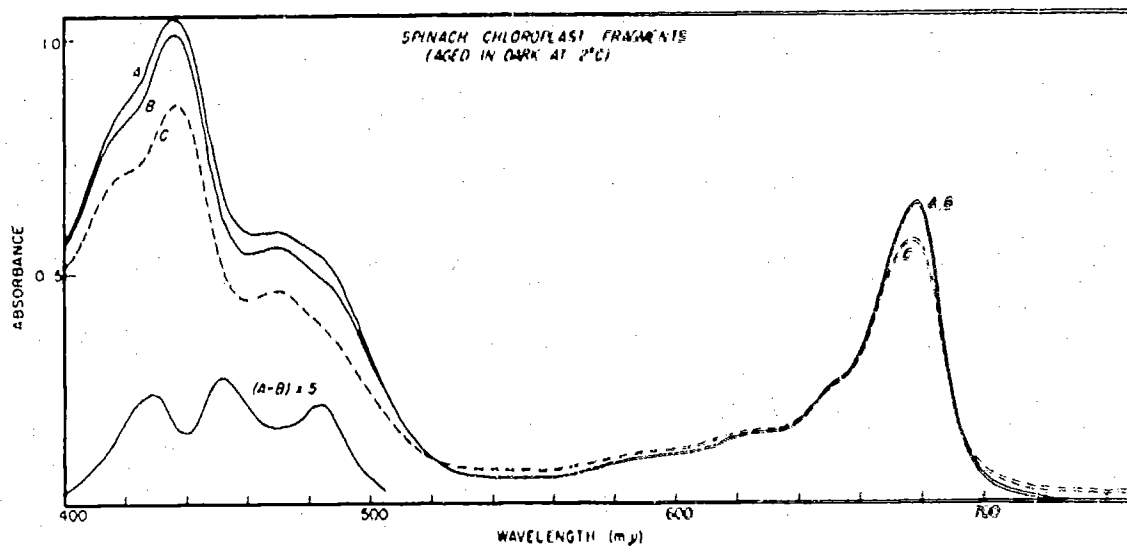

Fig. 2. Aging of chloroplast fragment suspension in the dark in air at 2°C: twice-sonicated fragments suspended in 10^{-2} M aqueous phosphate buffer, pH 7.4. Curve A: fresh sample immediately after preparation; Curve B: stored 2 days in dark at 2°C; Curve C: stored 2 weeks in dark at 2°C. Curve A-B: absorbency difference between curves A and B, multiplied 5 times.

decreased (by as much as 7%) in the 2-day-old sample. The substance responsible for this absorbency decrease is best characterized by subtracting the spectrum of the aged suspension from that of the fresh one. The resulting difference spectrum, also shown in Fig. 2, has maxima at 430, 452, and 485 m μ and is quite characteristic of carotenoid absorption.¹¹ The spectrum representing the two-week old material shows further bleaching including, now, that of the chlorophyll a. In addition, the 2-week-old sample has become somewhat turbid, as evidenced by the increase in apparent absorbency in the relatively transparent regions of the spectrum. It is significant to note that the shoulder in the spectrum of the fresh fragments at about 485 m μ has virtually disappeared in the 2-week-old material, whereas the one at 470 m μ has become relatively more pronounced. This indicates that the substances absorbing in the "carotenoid region" of the spectrum are not similarly affected by air oxidation. Barer has suggested that chlorophyll b may be responsible for some of the absorption in this region,⁸ which may account for the present observation of the relative stability of the material responsible for absorption at 470 m μ . The spectrum of chlorophyll b in ethyl ether exhibits principal maxima at about 453 and 642 m μ .⁶ The long-wave-length absorption maximum in the spectrum of the fragments is shifted to about 650 m μ , and the short-wave-length band would also be expected to be shifted comparably toward longer wave lengths. Such is the case with chlorophyll a, for which both bands are much more prominent in the spectrum. The tentative assignment of the absorption at 470 m μ in the spectrum of the fragments to chlorophyll b is therefore not unreasonable.

In a similar experiment, in which twice-sonicated fragments were suspended in 5×10^{-5} M phosphate buffer at pH 7.4 and aged at 2°C in the dark, essentially identical results were obtained.

The effect of light on the bleaching process is illustrated in Fig. 3. A sample of twice-sonicated fragments, suspended in 5×10^{-5} M phosphate buffer, pH 7.4, was placed directly in front of two 15-watt fluorescent lamps in a cold room at 2°C. The spectra show the pronounced acceleration of the bleaching process caused by light. The change in the shape of the spectrum indicates that the different components are changing at different rates. In particular, the shoulder at 485 m μ is seen to have virtually disappeared after the first day of illumination. The absorption maximum in the red shifts progressively to shorter wave lengths--a phenomenon that has been observed in previous studies of photobleaching.¹²

During the 3-day interval no increase in turbidity of the suspension, as measured by the apparent absorbency in the near infrared, is observed.

In all the experiments discussed thus far the wave length of maximum absorption in the red occurred at $678 \pm .5$ m μ in the freshly prepared suspensions. In several other preparations, however, the initial maximum occurred at 680.5 m μ . In one series of experiments with such a sample stored in weak

11. P. Karrer and E. Jucker, Carotenoids (Elsevier Publishing Co., New York, 1950); J. W. Porter, Arch. Biochem. Biophys. **45**, 291 (1953).

12. J. S. Brown and C. S. French, Plant Physiol. **34**, 305 (1959).

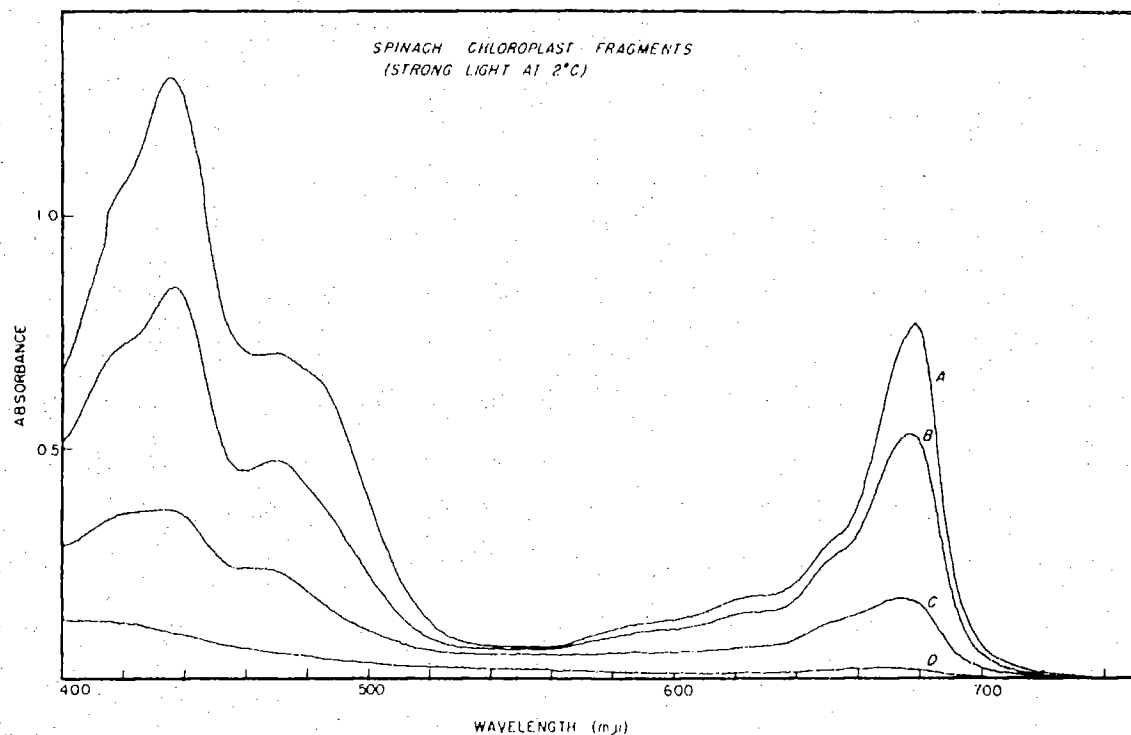

Fig. 3. Bleaching of chloroplast fragment suspension in strong light in air at 20°C; twice-sonicated fragments suspended in 5×10^{-5} M phosphate buffer, pH 7.4. Curve A: fresh sample immediately after preparation; Curves B, C, and D after 1, 2, and 3 days of illumination, respectively.

illumination (ambient room light) at 20°C, the progress of the bleaching was followed spectrophotometrically. After 16 hours the absorbency at the maximum of the red band was unchanged; however, the position of the maximum had shifted from 680.5 to 678.5 m μ . The difference between the two spectra is plotted in Fig. 4. The curve suggests that a component with maximum absorption near 687 m μ is disappearing and one with a maximum near 668 m μ is forming. Such a shift would be expected if a chlorophyll *a* aggregate or chlorophyll *a*-protein complex of some sort were breaking up to form monomeric chlorophyll. It is interesting to note that similar absorption shifts and difference spectra were noted by Shibata.¹³ It may be, therefore, that this shift in Fig. 4 is due to the presence of a small amount of Shibata's C 684 which gets converted to C 673 subsequent to the preparation procedure. The lack of agreement in wave-length maxima may arise from distortion in the difference spectrum in the present system resulting from spectral overlap of the absorptions of the components and partly from errors in subtracting curves which do not differ very greatly. During the same 16-hour interval a bleaching in the blue was observed and the difference spectrum shows it to have the same general shape and absorption maxima as the corresponding curve in Fig. 2, indicating that only carotenoids are undergoing bleaching during this interval. Subsequent aging produced a family of curves analogous to those in Fig. 3. The shift from 680.5 to 678.5 m μ , which had also been observed in several other previous cases, could not be repeated with subsequent preparations, all of which showed the absorption maximum initially at 678.5 m μ and began bleaching without any prior or associated marked shift in wave length. It is not known at present whether the variation in the maximum absorption of the red band of freshly prepared spinach chloroplast fragments is a consequence of variations in the spinach used or of the preparation procedure.

Conclusions

The ability to produce aqueous suspensions of small fragments of spinach chloroplast lamellae now permits accurate determination of the absorption spectra of plant leaf pigments essentially in their natural environment. At the same time the clarity and relative stability of such suspensions allows observation of detailed features and changes in the spectra of the solutions which could not be easily followed for scattering suspensions or systems in which settling is a problem. Nonscattering preparations have obvious advantages for studies of phosphorescence, luminescence, absorption transients, quantum yields, or other optical phenomena in which scattering and settling are often major complicating factors. One must, of course, remain aware that these fragments are not chloroplasts *in vivo*; however, it seems that they are capable of efficiently carrying out quantum-conversion processes identical with those occurring in the intact chloroplast.

13. K. Shibata, J. Biochem. (Japan) 44, 147 (1957).

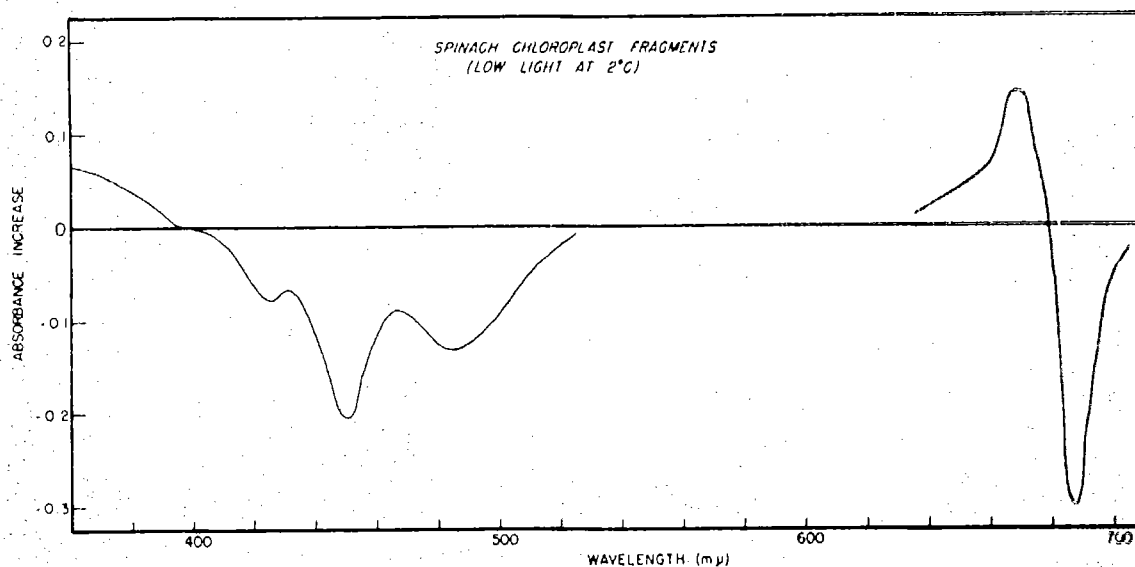

Fig. 4. Bleaching of chloroplast fragment suspension in low light at 2°C: small fragments in 5×10^{-5} M phosphate buffer, pH 7.4; increase in absorbency resulting in a freshly prepared suspension standing for 16 hours in ambient room light at 2°C.

The well-known protective effect of colored carotenoids toward the photosynthetic apparatus¹⁴ may be a result of the greater susceptibility of colored carotenoids than of chlorophyll to oxidation, either in the dark or in the light. The evidence of this study indicates that one or more colored carotenoids absorbing at 430, 450 to 455, and 485 to 490 m μ are irreversibly bleached to colorless or weakly colored products in the first stage of aging of chloroplast lamellae. This occurs, in part, before any bleaching of chlorophyll a, and probably of chlorophyll b, has taken place. It is quite likely that the bleaching is a consequence of air oxidation of the carotenoids and that this oxidation occurs much more rapidly in the presence of light. It would appear that the phenomenon is not simply a question of the chlorophyll's being oxidized simultaneously at a slower rate; the data definitely indicate that a certain fraction of the carotenoid is bleached before any of the chlorophyll is. Thus the former appears to exert a protective action toward the latter. The spectra also show that when the chlorophyll does begin to bleach there still remains a shoulder at 485 to 490 m μ , although it is appreciably reduced from that present initially. This shoulder eventually disappears completely before the chlorophyll bleaching has progressed very far. It appears, therefore, that part of the material responsible for absorption at 485 to 490 m μ does not confer protection against chlorophyll oxidation.

That the absorption at 470 m μ does not decrease nearly so rapidly as that at 485 to 490 m μ suggests a distinctly different origin for the two bands. This can be explained if either the 470-m μ band is due to chlorophyll b, which does not bleach initially as measured by its absorption at 650 m μ , or it is due to a colored carotenoid which is less readily oxidized than the one responsible for absorption at 485 to 490 m μ . The former explanation is held to be the more likely.

The author wishes to thank Dr. Roderic B. Park for furnishing most of the preparations of the chloroplast fragments and for very helpful discussions concerning the nature of the particles contained.

14. M. Griffiths, W. R. Sistrom, G. Cohen-Bazire, and R. Y. Stanier, *Nature* 176, 1211 (1955); G. Cohen-Bazire and R. Y. Stanier, *Nature* 181, 250 (1958).

2. PHOTOSYNTHETIC AND ESR BEHAVIOR OF A CHLAMYDOMONAS REINHARDI MUTANT DURING CHLOROPHYLL SYNTHESIS

G. M. Androes, J. Biggins, and M. F. Singleton

Introduction

Light-induced free radicals have been observed in many photosynthetic systems, but their role in quantum conversion and their function in natural photosynthesis are unknown. Light does not induce ESR (electron spin resonance) signals in etiolated leaves.¹ Similarly, a dark-grown nonchlorophyllous mutant of Chlamydomonas reinhardi* yields no photoinduced spin signal. However, this yellow, dark-grown mutant produces chlorophyll in the light and simultaneously develops photo-induced ESR signals. During greening, chlorophylls a and b are produced in about equal quantities over a period of 15 hours, by which time maximum pigment concentration is reached. An investigation was carried out on the relationship of photosynthetic activity and production of photo-induced free radicals to the amount of chlorophyll present in the greening organism.

Procedure

Cultures of the mutant were grown heterotrophically in six 1-liter flasks over periods of 8 to 14 days in the dark (three experiments). When the cultures were dense enough to provide the samples needed, the first flask was harvested at zero time and the remaining five flasks were exposed to uniform light of 700 ft-c (foot candles). These remaining cultures were harvested at 3-hour intervals. The following determinations were made on each sample:

- a. chlorophyll a and b concentration,
- b. rate of O₂ evolution,
- c. rate of C¹⁴O₂ fixation,
- d. equilibrium photo-induced ESR signal amplitude.

For all measurements the light intensities used were more than sufficient to light-saturate the samples. (See data from the third experiment in Table II.)

a. For the chlorophyll determinations 0.02 ml wet-pack cells were extracted with 5.0 ml 80 % aqueous acetone. The residue was removed by centrifugation and the optical density of the extract was measured at 700, 645, and 663 mμ. Chlorophyll content was calculated by the following formula.²

* Supplied by Dr. Ruth Sager.

1. B. Commoner, J. Townsend, and G. E. Pake, *Nature* 174, 689 (1954).
2. D. I. Arnon, *Plant Physiol.* 24, 1 (1949).

For D_{λ} = optical density with 1-cm-light-path cuvette at wave length λ ,

$$(D_{663} - D_{700}) 8.02 + (D_{645} - D_{700}) 20.2$$

= mg chlorophyll a + b per liter of 80% acetone extract.

The maximum chlorophyll content attained was 2.7 mg chlorophyll/ml wet-pack cells.

b. The O_2 evolution experiment was conducted in Warburg manometers each with 0.03 ml wet-pack cells diluted to 3.0 ml with bicarbonate buffer at pH 8.6. The sample was equilibrated at 23°C at light intensity of 5000 ft-c for 5 min, after which oxygen evolution was measured over a period of 30 min. The derived rates were corrected for respiration. The maximum rate of O_2 evolution attained was 3.2×10^3 μ l O_2 per mg chlorophyll per hr for the sample harvested at 12 hr.

c. In the $C^{14}O_2$ fixation experiment 0.03 ml wet-pack cells was suspended in 1.0 ml bicarbonate buffer at pH 8.6. After 5 min pre-illumination, 1.0 μ M $NaHC^{14}O_3$ (15 μ C) was added and the sample was illuminated for 2 min more at 5,000 ft-c and 23°C. The cells were killed with 4.0 ml cold methanol (absolute), resulting in an 80% aqueous methanol mixture. This mixture was left standing overnight at room temperature. Next day the cells were extracted twice with 80% methanol, twice with 20% methanol, and twice with water to remove the soluble fraction. The extracts were combined and evaporated under vacuum, followed by dilution to 0.05 ml with 20% methanol. A 10- λ aliquot was acidified and dried on a planchette and the total radioactive count measured. The extract was analyzed by two-dimensional chromatography, using 250- λ aliquots of the extracts on Whatman 4 paper and developing with phenol-water and butanol-propionic acid-water solvents. The chromatogram of the first sample, harvested at time zero, showed radioactive products indicative of dark CO_2 fixation into organic acids. All the subsequent samples, starting at 3 hr, showed a typical light CO_2 fixation pattern, the sugar phosphates and diphosphates being predominantly labeled.

d. The ESR measurements were performed on samples that were as concentrated as possible. The last four samples were dense suspensions of about 0.3 ml wet-pack cells plus several drops of culture media. On the other hand, the cultures harvested at zero time and at 3 hr had to be diluted by 2.5 times their wet-pack volume to fill the sample cell. All incident light was absorbed by the last four preparations, while about 90% of the incident light was absorbed by the first two. White light of intensities of 7,500 ft-c or more was used. This was more than sufficient to light-saturate the ESR signal. The maximum signal observed was 4.5 in. (noise \approx 0.3 in.) on the 12-hr sample with 10 gauss modulation amplitude and 3-sec instrument time constant. This signal is the composite of two overlapping lines which instrument sensitivity prevented our resolving in such young cultures. There was no observable change in the line shape or width during greening.

Our results are plotted in Fig. 5. The equilibrium ESR amplitude, the rate of $C^{14}O_2$ fixation, and the rate of O_2 evolution are all normalized so that the maximum value observed in each variable is equal to unity. These are plotted against chlorophyll a + b content, also normalized to unity at maximum value.

Table II. Compilation of results from Experiment 3 on various parameters during greening of a mutant of *Chlamydomonas reinhardi*. The ESR signal amplitude, the rate of $C^{14}O_2$ fixation, the rate of O_2 evolution, and the chlorophyll content are all normalized so that the maximum value observed in each variable is equal to unity.

Time in light (hr)	Ml. of wet-pack cells per liter of culture	ESR signal amplitude	O_2 evolution rate	O_2 fixation rate	Chlorophyll (a + b) content
0	0.32	0	0	0.14	0.06
3	0.37	0	0.28	0.36	0.08
6	0.51	0.19	0.85	0.59	0.20
9	0.45	0.41	0.83	1.00	0.79
12	0.64	1.00	1.00	0.96	0.83
15	0.56	0.95	0.46	0.84	1.00
32	----	----	0.88	----	0.84

Discussion

The data indicate:

1. An ESR signal grows in as the chlorophyll content of the culture increases.
2. The relationship between chlorophyll content and ESR amplitude is not linear, the major part of the ESR signal amplitude increase coming during synthesis of the last 20% of the chlorophyll.
3. The rate of photosynthesis, as measured by either the rate of O_2 evolution or the rate of $C^{14}O_2$ fixation, is maximal long before the ESR amplitude starts its steepest rise.

The amount of chlorophyll in the cell appears to limit the rate of photosynthesis up to a certain point. This would suggest that when the concentration of light-absorbing pigments passes a certain level, their energy-absorbing ability no longer limits the rate of O_2 evolution and CO_2 fixation, but some other process then becomes limiting. This may be represented schematically as follows:

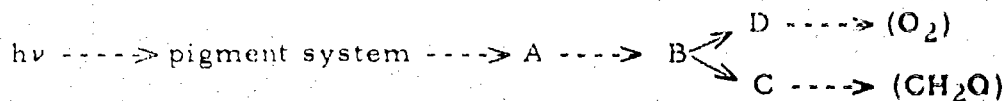

As the energy-absorbing power of the pigment system increases some follow-up step, such as $A \text{ ----} \rightarrow B$, becomes rate-limiting. This allows pools of A, etc., and excited pigment molecules to build up. In this view the radicals would then be in any or all of these pools.

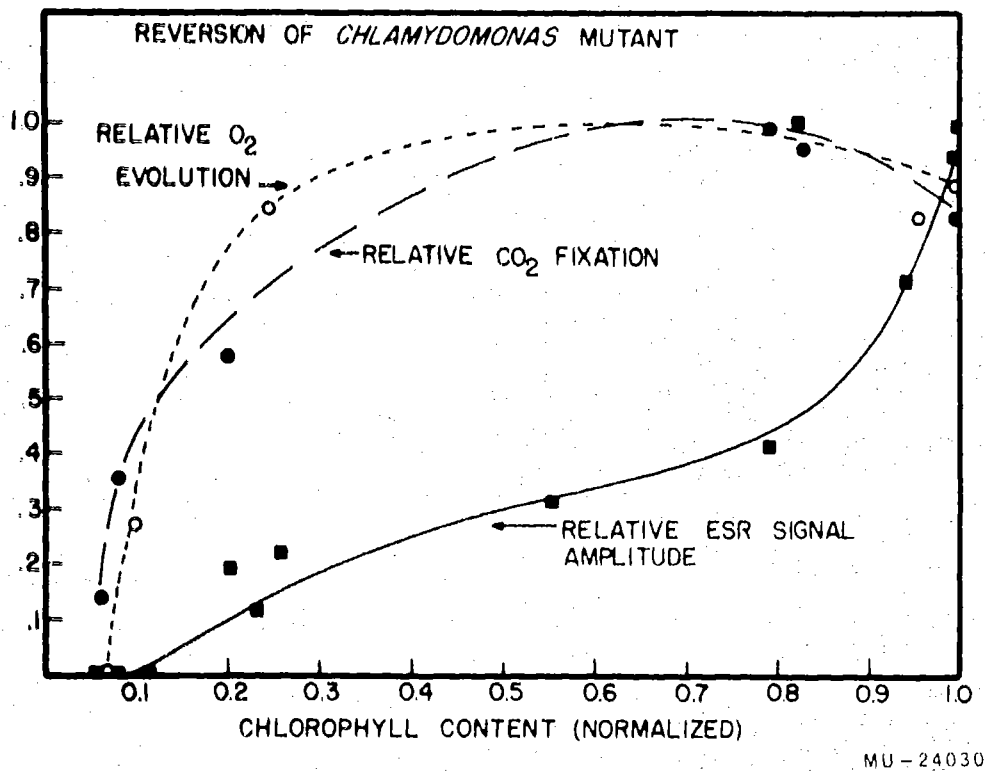

Fig. 5. The ESR amplitude, O₂ evolution rate, and C¹⁴O₂ fixation rate as functions of chlorophyll (a+b) content during the greening of a yellow mutant of Chlamydomonas reinhardi.

The steepest rise of signal amplitude as the last chlorophyll is synthesized suggests also that the highest efficiency for spin production is dependent upon the completion of some structural element containing chlorophyll.

We plan to repeat this experiment on Chlamydomonas reinhardtii in the near future.

1. ESR STUDIES OF CHROMATOPHORES FROM RHODOSPIRILLUM RUBRUM

G. M. Androes and M. F. Singleton

Introduction

The ESR (electron spin resonance) behavior of a red photosynthetic bacterium Rhodospirillum rubrum has been studied previously.¹ It was expected that further information could be obtained by using isolated chromatophores rather than whole cells. Chromatophores are small spherical particles approximately 1,000 Å in diameter and contain all the photosynthetic pigments. These particles perform both cyclic photophosphorylation and photo-oxidation reactions in light.

Procedure

Chromatophores were prepared from Rhodospirillum rubrum cultures which varied in age from 5 to 17 days.² After harvesting, the cells were resuspended in 0.1 M potassium glycolglycine buffer, pH 7.5. The following separation scheme was carried out at approx 0°C:

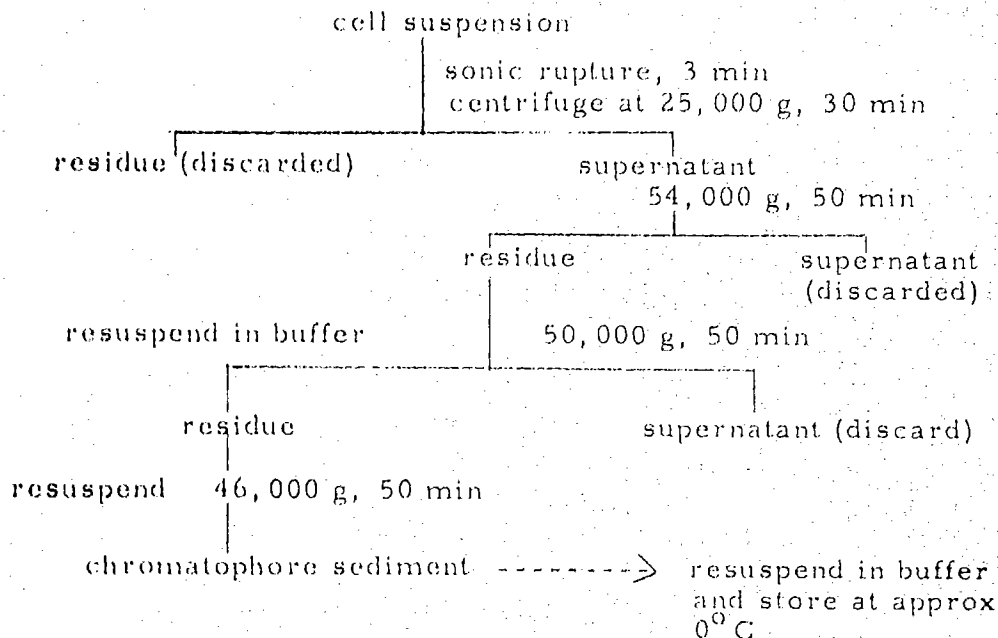

The optical density of the resuspended chromatophores was 1.6 at 880 mμ with a 1-cm cuvette path length. This measurement was made on chromatophores at 1/12 the concentration used for the ESR determinations.

1. P. Sogo, M. Jost, and M. Calvin, Radiation Research, Suppl. 1, 511 (1959).
2. A. W. Frenkel and D. D. Hickman, J. Biophys. Biochem. Cytology 6, 285 (1959).

Also, in the ESR measurements the effective path length of the sample was only 0.025 cm. Thus, the o.d. recorded in Fig. 6 represents a sample of the same thickness, but of greater concentration by a factor of 3.3 than that used in the ESR determinations. The chromatophore sample appeared only slightly colored in the ESR aqueous sample cell and most of the light used for inducing free radicals could pass through the cell. This helped eliminate the self-absorption effects observed in samples of the whole bacteria, which were infinitely thick compared with the distance of active light penetration.³

The action spectrum of equilibrium ESR signal amplitude was measured as a function of wave length of incident light. Monochromatic light from 600 to 1,000 m μ was used at intensities of 1.2×10^{15} and 1.2×10^{16} quanta/sec (Fig. 6).

Chromatophores were also prepared in a D₂O potassium glycyglycine buffer following the procedure described above, and the ESR photosignal appeared to be identical to that in the H₂O-buffer sample. In white light the widths were approximately 12 gauss from peak to peak with 1.25 gauss modulation amplitude. The light saturation curves were the same shape, and the rise and decay times of the signals appeared to be the same as in the H₂O-buffered sample.

Discussion

Although the chromatophores' ESR signal is nearly identical with the whole bacteria's signal, there are some interesting differences. Rise and decay times of the signal in the chromatophores are somewhat altered from those in the whole cell. This might be expected, since the terminations of the energy-transfer system have been removed. This would explain why for the chromatophores at room temperature the decay scheme contains a fast and a slow component, whereas the whole cell in aqueous suspension has only a single fast component.

Another interesting difference is that of the action spectra. In the action spectra made on thick suspension of whole bacteria, the maximum was shifted to the long-wave-length side of the chlorophyll absorption maximum because of self-absorption.³ However, the slightly colored chromatophore sample has its peak at the absorption maximum of the bacteriochlorophyll and, although there are probably still some self-absorption effects, this is nearer the true situation. Thus, it is evident that bacteriochlorophyll is the principal pigment responsible for spin production.

The study of chromatophores in D₂O buffer was suggested by an experiment of Commoner's in which he used Chlorella cultured in a 99.9% D₂O growth medium. The ESR resonances observed in these Chlorella were significantly narrowed by the substitution of D for H.⁴ If the width of

3. P. Sogo, L. Carter, and M. Calvin, Free Radicals in Biological Systems (Academic Press, Inc., New York, 1961), p. 311.
4. B. Commoner, Light and Life (Johns Hopkins Press, Baltimore, 1961), p. 356.

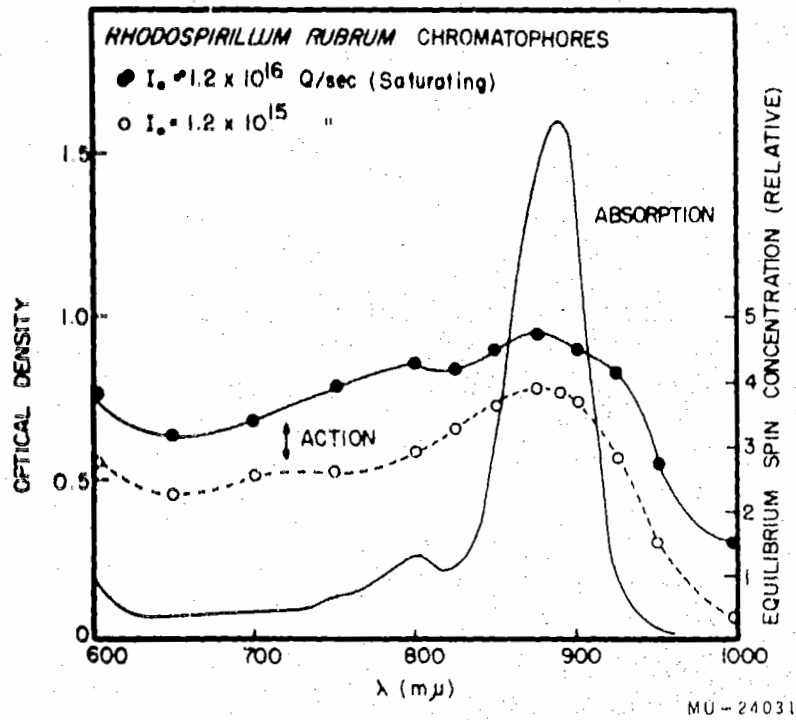

Fig. 6. Action spectrum of Rhodospirillum rubrum chromatophores.

resonance in chromatophores were in part due to neighboring H atoms, then preparing the samples in D_2O might exchange some of these H's for D's, and a change in line width would result. However, no change of ESR signal was observed in D_2O , meaning that if the line width is in part contributed by neighboring H's, these H's are not easily exchangeable.

4. A STUDY OF LIGHT-CATALYZED OXYGEN TRANSPORT IN PHOTOSYNTHESIS*

Elie A. Shneour

Most of the fruitful research on the redox reactions of photosynthesis has centered on the reducing moiety resulting from the photolysis of water. By contrast, our knowledge of the pathway of the oxidant is practically non-existent. The major stumbling block has been the lack of an adequate analytical tool. There exist no suitable radioactive oxygen isotopes. The stable isotopes, oxygen 17 and 18, require mass spectrographic analysis which is, at best, a cumbersome technique. Nuclear activation of O^{18} appears to be the most promising approach to this problem. This paper presents results obtained by means of the nuclear activation reaction $O^{18}(p,n)F^{18}$ of xanthophylls from spinach leaf chloroplasts treated with H_2O^{18} .

Pioneering work on an oxygen-transport function of xanthophylls[†] was carried out in this Laboratory by Dorough and Calvin¹ and elsewhere by Sapozhnikov and Lopatkin.² Although this evidence adduced by mass spectrographic analysis of O^{18} and by balance experiments respectively was equivocal, the mechanism suggested by Dorough and Calvin has now received substantial support (Fig. 7, $\textcircled{1}$).

Reaction I has been shown to take place in the dark in leaves of Elodea canadensis. Lutein is converted to its epoxide, violaxanthin^{3,4} (Fig. 7, $\textcircled{2}$).

Reaction II: Whether or not rearrangement of the epoxide to the furan occurs in vivo has not been determined. The furan isomer of violaxanthin, however, is well known. This beautiful golden yellow pigment, auroxanthin (Fig. 7, $\textcircled{3}$), is found associated with violaxanthin in the blossoms of Viola tricolor.⁵ Auroxanthin can also be produced in vitro by treatment of violaxanthin with dilute acid.⁶

* This work was done during the author's tenure of an Advanced Fellowship from the American Heart Association.

† The term "xanthophyll" is defined here as all C_{40} carotenoids containing oxygen.

1. G. D. Dorough and M. Calvin, J. Am. Chem. Soc. 73, 2362 (1951).
2. D. I. Sapozhnikov and A. B. Lopatkin, Dokl. Acad. Nauk S. S. S. R. 72, 413 (1950).
3. D. I. Sapozhnikov et al., Doklady Akad. Nauk S. S. S. R. 113, 2 (1957).
4. D. I. Sapozhnikov and N. V. Bazhanova, Doklady Acad. Nauk S. S. S. R. 120, 5 (1958).
5. P. Karrer and J. Rutschmann, Helv. Chim. Acta 25, 1624 (1942).
6. P. Karrer and E. Jucker, Helv. Chim. Acta 28, 300 (1945).

Fogelstrom-Fineman et al.¹⁰ Several experiments were necessary to obtain optimum activation. This was achieved finally by a proton bombardment at 4 ± 1 Mev and 2 ± 1 μ a for 10 min. Results are shown in Table III.

Table III. $O^{18}(p,n)F^{18}$ activation analysis of O^{18} in xanthophylls (expressed in counts/min $\times 10^{-3}$).

	Time elapsed after bombardment (hr)						
	2.5	3.5	4.5	6.5	7.5	9.0	18.0
Dark	72.4	56.0	40.7	20.5	14.4	8.3	0
1 min. Light	131.8	120.7	101.3	64.0	48.0	29.6	0
15 min. Light	81.3	62.3	46.5	24.0	17.3	10.2	0

Table IV. Extrapolated F^{18} radioactivity (at time zero) (in counts/min).

Dark	1.48×10^5
1 min Light	3.40×10^5
15 min Light	1.80×10^5

Extrapolation to zero time gave the initial F^{18} activities as shown in Table IV. The number of O^{18} atoms in each experiment was estimated by making the following assumptions:

- The efficiency of counting is 50 %.
- No O^{18} has been lost by thermal decomposition of the sample during the bombardment.

c. All O^{18} has been converted to F^{18} .

Then $\lambda F^{18} = 0.693/1.8 \text{ hr} = 0.385 \text{ hr}^{-1}$.

Since $I = I_0 e^{-\lambda t} = n = n_0 e^{-\lambda t}$, then $\frac{-dn}{dt} = \lambda n$.

For dark sample, $dn/dt_0 = 1.78 \times 10^7/\text{hr}$,

for 1 min illumination, $dn/dt_0 = 4.08 \times 10^7 \text{ d/hr}$,

for 15 min illumination $dn/dt_0 = 2.16 \times 10^7 \text{ d/hr}$.

10. I. Fogelstrom-Fineman, O. Holm-Hansen, B. M. Tolbert, and M. Calvin, Intern. J. Appl. Radiation and Isotopes 2, 280 (1957).

4. A STUDY OF LIGHT-CATALYZED OXYGEN TRANSPORT IN PHOTOSYNTHESIS*

Elie A. Shneour

Most of the fruitful research on the redox reactions of photosynthesis has centered on the reducing moiety resulting from the photolysis of water. By contrast, our knowledge of the pathway of the oxidant is practically nonexistent. The major stumbling block has been the lack of an adequate analytical tool. There exist no suitable radioactive oxygen isotopes. The stable isotopes, oxygen 17 and 18, require mass spectrographic analysis which is, at best, a cumbersome technique. Nuclear activation of O^{18} appears to be the most promising approach to this problem. This paper presents results obtained by means of the nuclear activation reaction $O^{18}(p, n)F^{18}$ of xanthophylls from spinach leaf chloroplasts treated with H_2O^{18} .

Pioneering work on an oxygen-transport function of xanthophylls[†] was carried out in this Laboratory by Dorough and Calvin¹ and elsewhere by Sapozhnikov and Lopatkin.² Although this evidence adduced by mass spectrographic analysis of O^{18} and by balance experiments respectively was equivocal, the mechanism suggested by Dorough and Calvin has now received substantial support (Fig. 7, (1)).

Reaction I has been shown to take place in the dark in leaves of Elodea canadensis. Lutein is converted to its epoxide, violaxanthin^{3,4} (Fig. 7, (2)).

Reaction II: Whether or not rearrangement of the epoxide to the furan occurs in vivo has not been determined. The furan isomer of violaxanthin, however, is well known. This beautiful golden yellow pigment, auroxanthin (Fig. 7, (3)), is found associated with violaxanthin in the blossoms of Viola tricolor.⁵ Auroxanthin can also be produced in vitro by treatment of violaxanthin with dilute acid.⁶

* This work was done during the author's tenure of an Advanced Fellowship from the American Heart Association.

† The term "xanthophyll" is defined here as all C₄₀ carotenoids containing oxygen.

1. G. D. Dorough and M. Calvin, J. Am. Chem. Soc. 73, 2362 (1951).
2. D. I. Sapozhnikov and A. B. Lopatkin, Dokl. Acad. Nauk S.S.S.R. 72, 413 (1950).
3. D. I. Sapozhnikov et al., Doklady Akad. Nauk S.S.S.R. 113, 2 (1957).
4. D. I. Sapozhnikov and N. V. Bazhanova, Doklady Acad. Nauk S.S.S.R. 120, 5 (1958).
5. P. Karrer and J. Rutschmann, Helv. Chim. Acta 25, 1624 (1942).
6. P. Karrer and E. Jucker, Helv. Chim. Acta 28, 300 (1945).

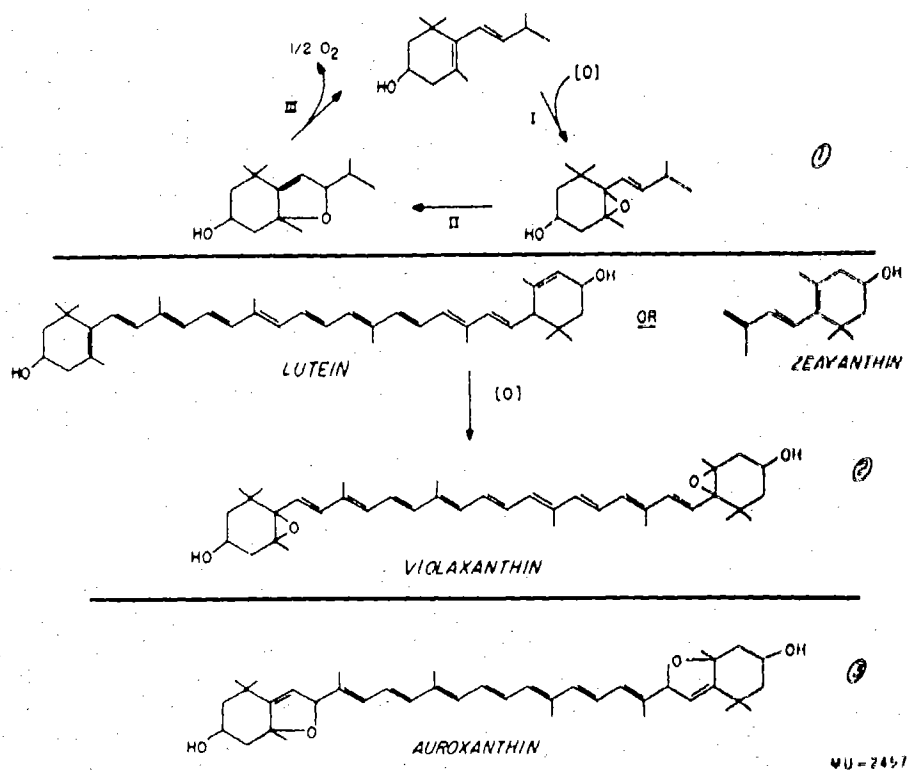

Fig. 7. Proposed oxygen transport mechanisms in xanthophylls.

Reaction III has been shown to be light-catalyzed in leaves of *Elodea canadensis*.^{3,4} The dark Reaction I is suppressed under anaerobiosis⁴ or upon addition of the inhibitor hydroxylamine, but these conditions have no effect upon light Reaction III.⁷

Warburg et al. have reported on their discovery of a labile carotenoid oxygenase enzyme system in *Chlorella* which is active in the dark and inhibited by light,⁸ thus adding further support to the concept of carotenoid involvement in oxygen transport.

Experimental Procedure

These experiments were carried out with the Hill-reaction active fragmented chloroplast fractions of *Spinacea oleracea*, prepared according to Park et al.⁹ One-half-ml aliquots of this fraction (containing 16 mg chlorophyll per liter and having a Hill activity of 211 $\mu\text{M O}_2$ evolved per hr per mg chlorophyll) were added to H_2O^{18} containing 20% O^{18} . (It should be noted here that the method of fractionation used to enrich water with O^{18} causes a concomitantly much greater enrichment of deuterium. Analysis of the H_2O^{18} used is reported as follows: 20% O^{18} , 0.7% O^{17} , 67% D, and 6 counts/min per mM T. Thus a potentially serious multiple isotope effect may be obscuring results. The ideal solution would be to synthesize O^{18} -enriched water with O_2^{18} and H_2).

Each such aliquot containing a final O^{18} concentration of 10% was flushed with O_2 -free argon gas and sealed in the dark. All experimental samples were exposed to H_2O^{18} for exactly 15 min at 20°C. Tube I was allowed to stand in complete darkness. Tube II was exposed to 10,000 ft-c incandescent illumination for 1 min. Tube III was exposed to the same illumination for 15 min.

At the end of the 15-min period, the xanthophyll fractions were rapidly extracted, then isolated according to the procedures described in paper 5 of this report.

The combined xanthophylls of bands I to IV from each tube were plated as 1-cm-diameter spots on reactor-grade tantalum plates and exposed to a proton flux in the Crocker 60-inch cyclotron, according to the procedure of

7. D. I. Sapochnikov et al., Doklady Acad. Nauk S.S.S.R. Engl. Transl., p. 219 (1959).
8. Von O. Warburg et al., Z. Naturforsch. 13b, 437 (1958).
9. R. B. Park, N. G. Pon, K. P. Louwrier, and M. Calvin, Biochem. et Biophys. Acta 42, 27 (1960).

Fogelstrom-Fineman et al.¹⁰ Several experiments were necessary to obtain optimum activation. This was achieved finally by a proton bombardment at 4 ± 1 Mev and 2 ± 1 μ a for 10 min. Results are shown in Table III.

Table III. $O^{18}(p,n)F^{18}$ activation analysis of O^{18} in xanthophylls. (expressed in counts/min $\times 10^{-3}$).

	Time elapsed after bombardment (hr)						
	2.5	3.5	4.5	6.5	7.5	9.0	18.0
Dark	72.4	56.0	40.7	20.5	14.4	8.3	0
1 min. Light	131.8	120.7	101.3	64.0	48.0	29.6	0
15 min. Light	81.3	62.3	46.5	24.0	17.3	10.2	0

Table IV. Extrapolated F^{18} radioactivity (at time zero) (in counts/min).

Dark	1.48×10^5
1 min Light	3.40×10^5
15 min Light	1.80×10^5

Extrapolation to zero time gave the initial F^{18} activities as shown in Table IV. The number of O^{18} atoms in each experiment was estimated by making the following assumptions:

- The efficiency of counting is 50 %.
- No O^{18} has been lost by thermal decomposition of the sample during the bombardment.
- All O^{18} has been converted to F^{18} .

Then $\lambda F^{18} = 0.693/1.8 \text{ hr} = 0.385 \text{ hr}^{-1}$.

Since $I = I_0 e^{-\lambda t} = n = n_0 e^{-\lambda t}$, then $\frac{-dn}{dt} = \lambda n$.

For dark sample, $dn/dt_0 = 1.78 \times 10^7/\text{hr}$,

for 1 min illumination, $dn/dt_0 = 4.08 \times 10^7 \text{ d/hr}$,

for 15 min illumination $dn/dt_0 = 2.16 \times 10^7 \text{ d/hr}$.

10. I. Fogelstrom-Fineman, O. Holm-Hansen, B. M. Tolbert, and M. Calvin, Intern. J. Appl. Radiation and Isotopes 2, 280 (1957).

Expressed in moles, these results are:

for dark sample, 7.67×10^{-17} M O^{18} ;

for 1 min illumination, 1.76×10^{-16} M O^{18} ;

for 15 min illumination, 9.32×10^{-17} M O^{18} .

Each sample was estimated to contain on the order of .01 micromole xanthophylls. The enormous discrepancy between this value and the calculated amount of activated O^{18} is immediately apparent. It is probable that assumptions b and c are not valid. In addition, the technical problem of proton beam homogeneity and flux control has not been solved. The results here are confirmed, however, by a recent paper of Sapozhnikov et al.¹¹ Although no quantitative significance can be ascribed to these findings, it now appears likely that xanthophylls are associated with an oxygen-linked function in photosynthesis.

11. D. I. Sapozhnikov et al., *Botan. Zhur.* 46, 673 (1961).

5. A STUDY OF LIGHT-CATALYZED HYDROGEN TRANSPORT UNDER PHOTOSYNTHETIC CONDITIONS.

PART II. CAROTENOIDS CONTAINING HYDROXYL GROUPS*

Elic A. Shneour

Carotenoids are intimately associated with the photosynthetic apparatus of green plants, algae, and photosynthetic bacteria. Yet no clear-cut function for these ubiquitous substances has been found. The possibility that the carotenoids might be involved in hydrogen transport has been the object of these studies. In Part I, evidence was presented to preclude such a role for hydrocarbon carotenoids in model systems and in chloroplasts of spinach leaves.¹ In this second part, the major hydroxyl-containing carotenoids (hereinafter referred to as xanthophylls) of green plants, lutein and zeaxanthin, are considered in the role of hydrogen carriers in photosynthesis. These investigations were also carried out with tritium oxide as the substrate. They are therefore subject to the same limitations described earlier. Additional limitations are imposed on the study of the xanthophylls by these techniques: Although lutein (3, 3' dihydroxyl derivative of α -carotene) and zeaxanthin (3, 3' dihydroxyl derivative of β -carotene) occur mostly in the free state, their dipalmitic esters are sufficiently important² to require saponification in order to recover a reproducibly high fraction of these xanthophylls for tritium assay and characterization (Fig. 8). Saponification, on the other hand, may cause tritium-hydrogen exchange during isolation procedures. This problem has been circumvented to some extent by comparisons between saponified and unsaponified extracts.

Experimental Procedure

Both nonbiological and spinach chloroplast systems were used for these studies. Authentic samples of highly purified xanthophylls necessary for characterization of pigments were kindly provided by Dr. H. H. Strain, Argonne National Laboratory, and by Dr. J. H. C. Smith, Carnegie Institution of Washington. Experiments were carried out with active fragmented chloroplast fractions from Spinacea oleracea treated with tritium oxide and illuminated as reported earlier.¹ Xanthophylls were then chromatographed on kieselguhr-treated paper and developed with 3% isopropanol in petroleum ether. They yielded five major bands, as follows:

* This work was done during the author's tenure of an Advanced Fellowship from the American Heart Association.

1. E. A. Shneour, in Bio-Organic Chemistry Quarterly Report UCRL-9652, April 1961, 99-104.
2. P. Karrer and E. Jucker, Carotenoide (Verlag Birkoüser A. G., Basel, 1948).

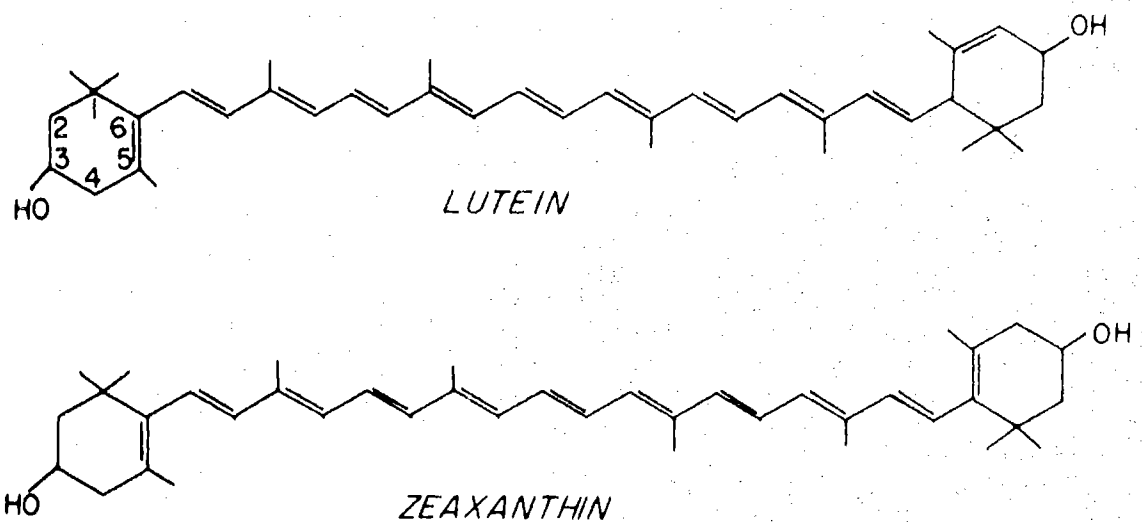

MU - 24569

Fig. 8. Comparison of lutein and zeaxanthin.

Band I (origin)	Chlorophylls, some highly oxidized xanthophylls
Band II	Xanthophyll mixture, including neoxanthin, flavoxanthin, and violaxanthin
Band III	Zeaxanthin
Band IV	Lutein
Band V	Xanthophyll mixture, mostly cryptoxanthin

These bands were eluted directly into separate 20-ml counting flasks containing 10 ml scintillation solution #2, and assayed in a Packard Automatic Tri-Carb Scintillation counter, after chlorine water bleaching.³ Except for the isolation of xanthophylls, all procedures were identical to those described in Part I of these studies.

A. Isolation of Xanthophylls from Pyridine or Dioxane Model Systems

At the conclusion of the experiments, the contents of each sample tube was dumped into 10 ml of NaCl-saturated water. Several 1-ml fractions of peroxide-free diethyl ether were then added and stirred to extract the lipoids. The ether extracts (epiphase) were then washed free of tritium oxide by shaking with several successive fractions of NaCl-saturated water until no radioactivity remained in the aqueous phase (hypophase). Since purified xanthophylls were used for the model system, no saponification was carried out. The washed ether extract was dried with anhydrous sodium sulfate, filtered, and distilled off in vacuo at 30°C. The residue was redissolved in a small amount of an ethyl ether-ethanol (1:1) mixture and chromatographed on Schleicher & Schuell Paper No. 287 according to the procedure described by Jensen & Jensen.⁴ No significant radioactivity associated with the xanthophylls was found under the conditions used for these experiments.

B. Isolation of Xanthophylls from Spinach-Leaf Chloroplasts

At the conclusion of the experiments, the contents of each sample tube was transferred to 1.0 ml of an acetone-methanol (7:2) mixture. Two ml peroxide-free ethyl ether was added with stirring, followed by 10 ml NaCl-saturated aqueous solution. Several 2.0-ml ether fractions were used to extract the aqueous phase. The combined ether extracts were washed with NaCl-saturated solution until no radioactivity remained in the aqueous phase. The ether extract was distilled off in vacuo. To the residue, 0.1 ml water and 1.0 ml of a 5 M methanolic KOH solution were added with stirring, and the mixture was allowed to stand at room temperature for 5 min in darkness and under an argon atmosphere. Two ml of peroxide-free diethyl ether was then added, followed by 10 ml NaCl-saturated water. The ether extract was collected and added to a second 2.0-ml ether extract. The combined ether extracts were washed free of alkali with successive 10-ml portions of NaCl-saturated water. The ether extract was then dried with anhydrous sodium

3. E. A. Shneour, in Bio-Organic Chemistry Quarterly Report UCRL-9652, April 1961, 105.

4. A. Jensen and S. L. Jensen, Acta Chim. Scand. 13, 1863 (1959).

sulfate, filtered, and distilled off in vacuo at 30^oC. The residue was redissolved and chromatographed as described above. The chromatograms do not show a Band I after complete saponification. Bands II through V were eluted, bleached, and assayed for radioactivity. Results are shown in Table V. It can be seen that no significant radioactivity appears associated with the xanthophylls.

The over-all conclusion, therefore, is that both the hydrocarbon and hydroxylated carotenoids do not participate in hydrogen transfer processes in photosynthesis.

Table V. Spinach leaf sonicated chloroplast fraction in 0.01 M phosphate, pH = 7.2. Trichlorophenol endophenol Hill activity: 218 μ M O₂ evolved per hr per mg chlorophyll; 23.0 mg chlorophyll per liter. Each flask contained 0.1 ml T₂O (109 mC T₂O per ml). Final specific activity: 1.97 μ C/ μ M.

	Counts per minute		
	Total	Less background	Plus internal standard
Background	43	0	--
Internal standard	8486	8443	--
Band 2, dark	46	3	8150
illuminated	45	2	7784
Band 3, dark	51	8	7703
illuminated	62	19	7874
Band 4, dark	51	8	7977
illuminated	43	0	7671
Band 5, dark	61	19	7973
illuminated	47	5	7787

6. FURTHER STUDIES ON THE FORMATION OF METHYL PHOSPHATE
BY TREATMENT OF $P^{32}O_4$ -FED SPINACH CHLOROPLASTS
WITH METHANOL

Johannes Ullrich*

"Killing" sonically fragmented spinach chloroplasts with 80 % methanol after incubation with $P^{32}O_4$ at pH 8 produces monomethyl phosphate. Tyszkiewicz assumed that this compound is formed in a nonenzymic reaction by a still unknown phosphate donor of enzymic origin, because she was able to get some methyl phosphate even after killing the samples by short boiling and adding the methanol later.^{1, 2, 3} She also assumed a relation between formation of methyl phosphate and the presence of some cofactors, ADP, and light.

Based on these hypotheses, her experiments have now been repeated, varied, and extended, sometimes under completely different conditions. Some of the first results thereof have been given in a preliminary report⁴ and are pointed out more completely in this paper, together with new results.

General Experimental Procedures

The conditions of the isolation procedure for the spinach chloroplasts were changed to give a higher yield. Five hundred g of fresh, completely turgid spinach leaves without the major part of the midrib were cut into 0.5-cm strips at 0° and homogenized for 30 sec in 1 liter of a precooled solution of 0.5 M sucrose, 0.1 M tris (hydroxymethyl)-aminomethane, and 0.01 M ethylenediaminetetraacetic acid (sodium salt), adjusted to pH = 8.1 by addition of HCl. After being squeezed through 12 layers of commercial cheesecloth, the suspension was centrifuged for 5 min at 200 g to remove all the larger particles. Then the chloroplasts were spun down from the supernatant by centrifugation for 15 min at 1,000 g. They were resuspended in 100 ml of a solution of 0.5 M sucrose, 0.002 M tris, and 0.0002 M EDTA, adjusted to pH = 8.1 as previously described, and centrifuged for 30 min again at 1,000 g. The precipitate was resuspended in 10^{-3} M tris buffer of pH = 8.1 to give a total volume of 40 to 50 ml of a solution still containing a considerable quantity of sucrose. In most cases, the suspension was sonicated for 90 sec in a Raytheon sonicator. All these operations were carried out at temperatures very near to 0°.

The chlorophyll content of the suspension was determined by light-absorption measurement in 80 % acetone at 663 and 645 m μ or at 652 m μ . In

*NATO Fellow from University of Bonn, Bonn, Germany, 1961-62.

1. Edwige Tyszkiewicz, in Bio-Organic Chemistry Quarterly Report, UCRL-9519, Jan. 1961, p. 58.
2. Edwige Tyszkiewicz, in Bio-Organic Chemistry Quarterly Report, UCRL-9652, April 1961, p. 117.
3. E. Tyszkiewicz, G. Gingras, and M. Calvin, Biochim. Biophys. Acta 50, 376-377 (1961).
4. Johannes Ullrich, in Bio-Organic Chemistry Quarterly Report, UCRL-9772, June 1961, p. 95.

general, the suspension contained between 1.3 and 2.0 mg chlorophyll per ml. The pH of the newly sonicated mixture was about 7.5 to 7.7. During storage at 0°, it went down progressively, sometimes as far as pH 3.0 within 2 weeks. When the suspension was stored frozen, pH changes did not occur.

If not stated otherwise, the feeding and killing experiments were carried out in small screw-cap vials with 0.1 ml of the $P^{32}O_4$ (at least 1 μC of P^{32}) solution, adjusted to pH = 8.1 with HCl and NaOH (containing 10^{-4} M $P^{31}O_4$ as carrier, metal ions, and cofactors only if specially mentioned), 0.4 ml of the chloroplast suspension, and 2.0 ml of organic solvent as "killing agent." The time between the addition of the chloroplast suspension to the phosphate solution and "killing" with the organic solvent is called "incubation time." During this time the samples were shaken in a water bath at 20 to 25° and illuminated intensely by a set of fluorescent lamps. To make the incubation time zero, the organic solvent was added before the chloroplast suspension, and there was no special shaking and illumination. Between 1/10 and 1/5 of the final sample (solution and precipitate together) was put on the origin of a 57 x 46-cm Whatman No. 4 paper. The chromatogram was run in the first dimension (lengthwise on the paper) for 14 hr with a mixture of 1.2 g EDTA, 100 ml conc. NH_3 solution, 1,450 ml water, and 2,520 ml isobutyric acid. In the second dimension it was run for about 20 hr with a freshly prepared mixture of 1,800 ml propionic acid, 3,750 ml n-butanol, and 2,453 ml water. After drying, the chromatograms were radioautographed for several days, in general with double-coated x-ray film. Subsequently the spots on the chromatograms were counted.

Experimental Details and Results

1. Variation of the incubation time from 0 through a few minutes up to 5 hr resulted in a more or less rapid build-up and turnover of the several organic phosphates usually involved in photosynthesis and some side reactions, but the yield of methyl phosphate, when the sample was "killed" with methanol, turned out to be completely independent of the incubation time (even if it is 0); the sample had only to have been stored long enough (several days) before it was put on the paper.

2. Treatment of the chloroplast suspension with methanol up to a few days before the addition of the $P^{32}O_4$ substrate only slowly decreased the quantity of methyl phosphate formed. "Killing" the mixture with acetone and adding methanol up to some days later did not appreciably affect the formation of methyl phosphate. However, when the mixture was killed with acetone and then dried by an air flow at room temperature, addition of methanol did not result in any formation of methyl phosphate. Freeze-dried chloroplasts, on the contrary, still form methyl phosphate, when fed with $P^{32}O_4$ and killed with methanol.⁵ Storage of the chloroplast suspension for some days at 0° cut down the formation of all the phosphates of photosynthetic origin, but scarcely affected the yield of methyl phosphate. Frozen stored chloroplast suspensions lost their photosynthetic phosphorylation activity more slowly. Chloroplasts not ruptured by sonication kept their activity longer than sonicated

5. Ulrich Heber (Lawrence Radiation Laboratory), private communication, July 1961.

suspensions. It never was possible to get any formation of methyl phosphate by use of a boiled or even briefly heated chloroplast suspension or by replacement of the enzyme only with 10^{-3} M tris buffer of pH = 8.1. Exclusion of light during the incubation cut down the formation of most of the photosynthetic phosphates, but did not affect the yield of methyl phosphate. In no case has it been possible to get methyl phosphate by adding the methanol to a sample previously heated in boiling water, even when the heating was limited to half a minute.

3. Some experimental results showed that the amount of methyl phosphate depended on conditions of storage of the completed mixture before the chromatography. This led to investigation of the speed of methyl phosphate formation after the addition of the methanol to the reaction mixture. A larger sample (without incubation) was mixed and divided into two parts. One of them was stored at room temperature, the other one heated in an oven to a temperature somewhat below the boiling point of methanol (about 55°). After definite times, samples of both parts of the mixture were put on chromatograms. Figures 9 and 10 show the results of this experiment. At room temperature, the yield of methyl phosphate increased up to 2 days and then leveled off. The heated sample, on the other hand, stopped after a short time, probably when it reached the killing temperature, and no longer formed methyl phosphate. The experiment has to be repeated with immediate heating; in this case no formation of methyl phosphate should be expected.

When following the pH changes in the chloroplast suspension for 2 weeks at 0°C , I found that there was a considerable decrease in pH, from about pH 8 down to pH 3. It was expected that similar pH changes would take place in the mixture containing the "killing agent." Measurements of a number of samples showed, however, that the pH of the killed samples never did fall below 7.4. So there was no possibility that an acid catalysis might be responsible for the formation of the methyl phosphate.

4. To get some idea what part or kind of compound in the chloroplast system is performing the phosphorylation of the methanol, unsonicated and sonicated chloroplast suspensions were fractionated by centrifugation for 1 hr at 80,000 g. The precipitate was resuspended in 10^{-3} M tris buffer of pH = 8.1 to give the original volume. In addition, some "recombinate" was prepared by reunification of the precipitate with the supernatant (both fractions homogenized together). Eight different suspensions were used for comparison:

- I. Unsonicated whole mixture
- II. Sonicated whole mixture
- III. Unsonicated precipitate
- IV. Sonicated precipitate
- V. Unsonicated supernatant (nearly free of chlorophyll)
- VI. Sonicated supernatant (containing only a little chlorophyll)
- VII. Unsonicated recombinate
- VIII. Sonicated recombinate

In the usual experiment, they all formed considerable quantities of methyl phosphate except No. V, which gave only a very low yield. A quantitative

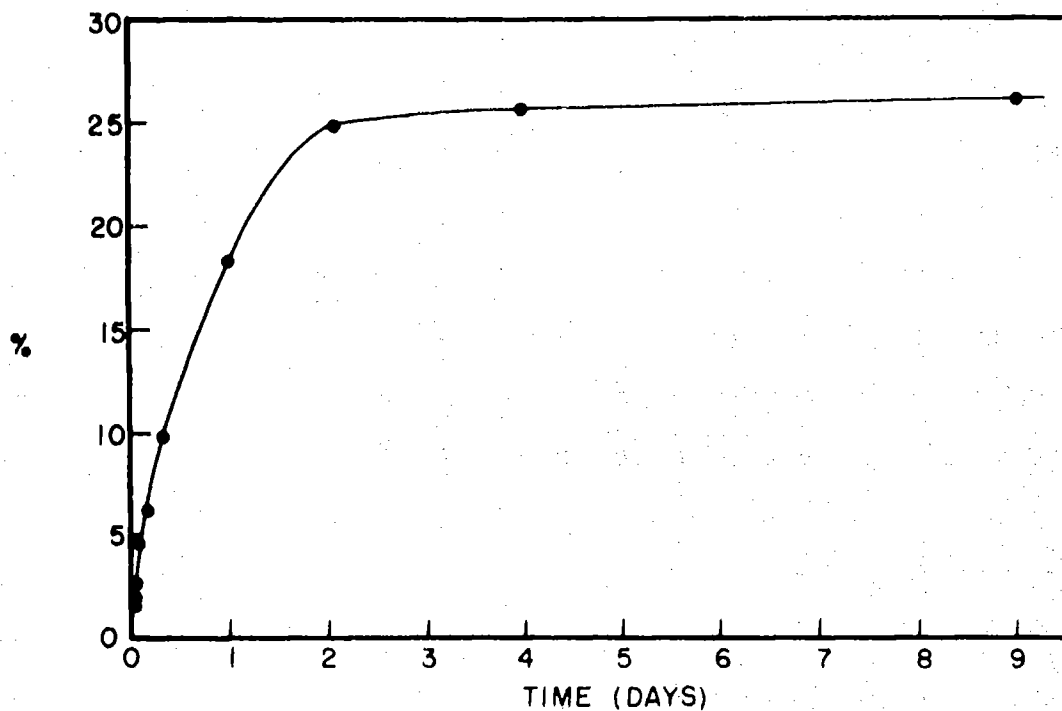

MU-24571

Fig. 9. Yield of methyl phosphate formed by sonicated chloroplast suspension (0.4 ml) after addition to a mixture of methanol (2.0 ml) and $P^{32}O_4$ solution (0.1 ml) without carrier phosphate at 25°C.

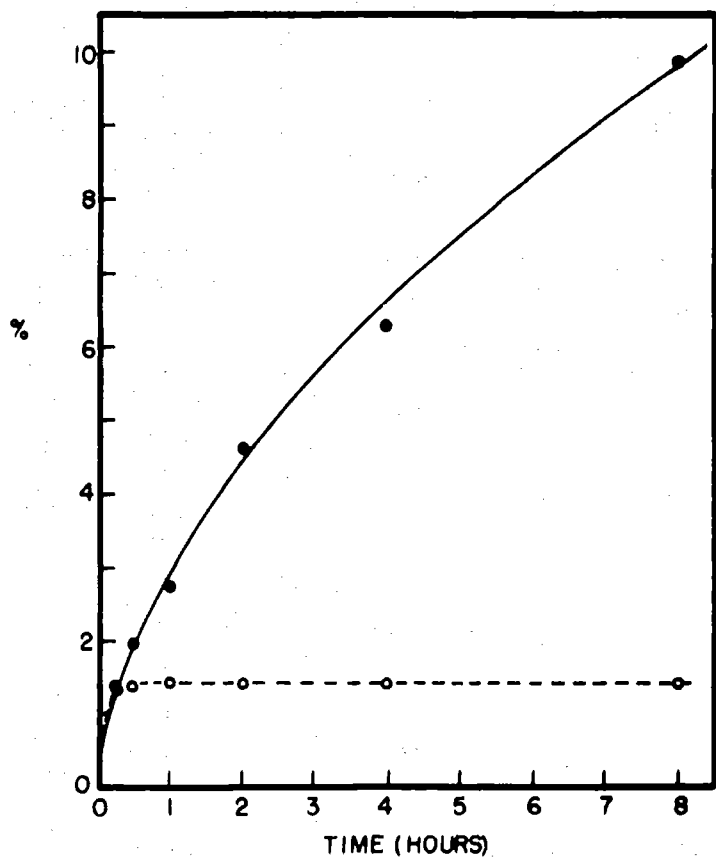

MU-24572

Fig. 10. Solid curve: enlarged beginning of the curve in Fig. 9; dashed curve: yield of methyl phosphate formed by a mixture identical to that in Fig. 9, but heated in an oven to 55°C. The heating started slowly, therefore some methyl phosphate could be formed before the enzyme stopped working.

comparison is difficult, because the samples were not stored for the same time and not allowed to react completely (the facts pointed out before in No. 3 were still unknown, when these experiments were performed).

5. It was of interest to find out whether other compounds with alcoholic hydroxyl groups would also be phosphorylated in similar experiments. Tyszkiewicz already found that ethanol reacts in the same way, but with somewhat lower yield, to form methyl phosphate, and she tried also, but unsuccessfully, *n*-propanol and *n*-butanol.³

Because of the limited solubility of higher alcohols in water, it was necessary to use mixtures of acetone with the alcohol in order to get comparable results. First a series of methanol-acetone mixtures was tried out. The results are shown in Fig. 11. For the alcohol comparison series, mixtures of 50% alcohol and 50% acetone (measured by volume) were chosen. Figure 12 shows the results: the yield of *n*-alkylphosphates decreases with the number of C atoms in the alkyl residue. Secondary alcohols react much more slowly than primary ones; tertiary butanol gave nearly no reaction.

The chromatograms of these samples had to be run for a shorter time, so that the solvent front did not approach the edge of the paper, because the higher alkyl phosphates run very close to the solvent front in both dimensions. Ethyl, *n*-propyl, and *n*-butyl phosphates were identified by cochromatography with commercial samples, and there cannot be any doubt about the identity of the other compounds.

In some orientation experiments, ethylene glycol, glycerin, D-glucose, and D-fructose were tested in low concentrations mixed with the usual amount of acetone. Only the two sugars gave spots running with the same R_F values as the corresponding sugar phosphates; the yield was 1.6% for glucose, 4.8% for fructose. The cochromatography of the spots is not yet accomplished. When ADP was contained in the acetone-killed mixture, no formation of ATP could ever be found.

6. A number of experiments designed to isolate the previously postulated phosphate donor, which should form methyl phosphate when treated with methanol, were unsuccessful.

A freshly prepared acetone-killed sample (incubation time = 0) was run in only one dimension with a modified solvent system in which the ammonia (which was thought to be destructive for compounds like the expected phosphate donor) was replaced by an equimolar quantity of trimethylamine. Two small new spots appeared on the chromatogram, not present in the simultaneously run methanol-killed mixture, but it was impossible to make these spots or any other part of the chromatogram react with methanol to form methyl phosphate, even when the still wet chromatogram was cut into strips and the strips were treated with the alcohol.

The same sample, without intermediate drying on the paper, that could have destroyed the donor in the chromatography experiment, was electrophoretically separated on paper in 0.01 M tris buffer of pH = 8.1 for 3 hr at 1,500 v (current ascending from 9 to 22 ma during the experiment). A small spot not occurring in the methanol-killed sample, in addition to the big phosphate spot, was obtained. However, treatment of the still wet paper, cut into strips, with methanol yielded no methyl phosphate.

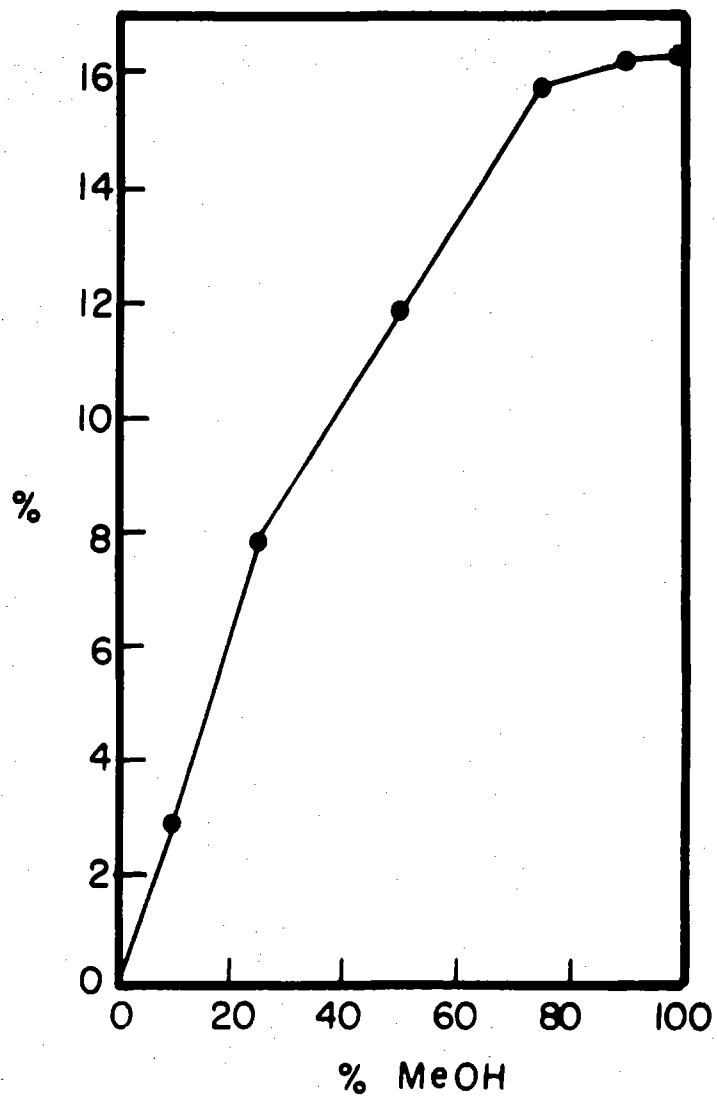

MU - 24573

Fig. 11. Yield of methyl phosphate in mixtures of methanol and acetone after 24 hours at 25°. No incubation.

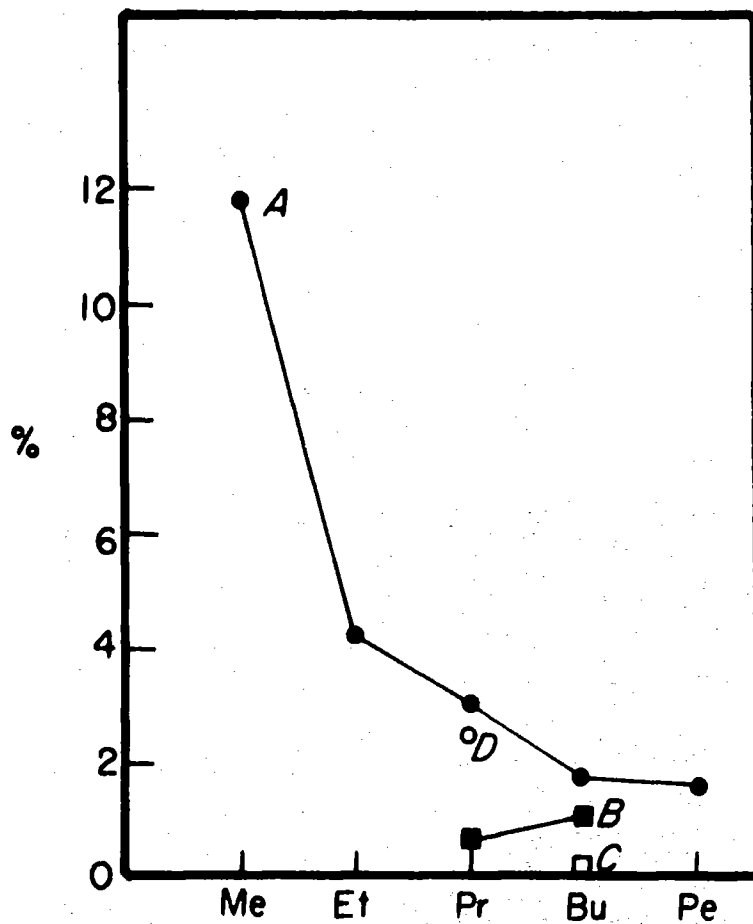

MU - 24574

Fig. 12. Yield of alkyl phosphates after treatment with 1:1 mixtures of alcohol and acetone for 16 hours at 25°. No incubation. A, primary alcohols; B, secondary alcohols; C, tertiary butanol; D, allyl alcohol.

Discussion of the Results

The experiments, especially those mentioned under No. 3 in the experimental part, show that the working hypothesis of E. Tyszkiewicz, which assumes that there is a phosphate donor formed by enzymic synthesis which gives alkyl phosphates in a nonenzymic reaction, is untenable.

It seems much more probable that some protein in the chloroplast system, apparently a phosphatase, catalyzes the exchange of phosphate between the alcohol and the water contained in the samples to give an equilibrium which can only be accomplished by strong acid or by an active enzyme.

This explanation of the data is supported by a rough calculation of the changes in free energy in this reaction, based on the often approached or even exceeded yield of 20% methyl phosphate:

At pH = 7.5, the back reaction can roughly be given by the equation

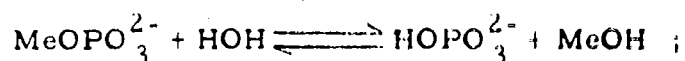

$$K = \frac{[\text{HOPO}_3^{2-}] \cdot [\text{MeOH}]}{[\text{MeOPO}_3^{2-}] \cdot [\text{HOH}]} = 7.14 ;$$

$$\Delta F = - RT \ln K = 1.986 \times 298 \times 2.303 \times 0.853 = - 1.16 \text{ kcal.}$$

In esters of phosphoric acid ΔF of the hydrolysis is in general between -3 and -5 kcal. The calculated value in the investigated reaction is of the same order of magnitude, although it still includes large errors caused by nonincorporation of the additional ions in the solution and by the high concentration, whereas the equation applies only to very dilute solutions. So the ΔF seems to approach the usual values for alkyl phosphates quite well.

In future experiments an attempt will be made to approach the supposed equilibrium from the other side, starting with labeled methyl phosphate in methanol-water mixtures. Tyszkiewicz has already mentioned some experiments on the hydrolysis of methyl phosphate by sonicated chloroplasts. If it is possible to approach the equilibrium from both sides, an intermediate high-energy phosphate donor cannot be involved in the formation of the methyl phosphate by the chloroplasts.

An important and surprising result of all this investigation will then be the extremely high stability of the phosphatase catalyzing the reaction, which is still active in mixtures containing 80% alcohol or acetone at room temperature for several days.

7. THE NUCLEIC ACID CONTENT OF SPINACEA OLERACEA CHLOROPLASTS

John Biggins and Roderic B. Park

INTRODUCTION

Several workers have analyzed the chloroplasts of higher plants for polynucleotide content.¹⁻⁹ However, there is considerable quantitative disagreement in the results, probably owing to the methods employed. These methods include (a) cytochemical procedures which depend upon the specific staining of ribonucleic acid (RNA) and deoxyribonucleic acid (DNA) in the chloroplasts of intact cells, and (b) the chemical analysis of RNA and DNA in chloroplasts isolated in aqueous media.

The amounts of nucleic acid reported in chloroplasts using cytochemical procedures are at the lower limit of the methods' sensitivity. This lack of sensitivity is circumvented by direct chemical analysis of isolated chloroplasts for RNA and DNA, but in this procedure artifacts are introduced owing to contamination of the plastids by other cell fragments during isolation from the cellular homogenate.¹⁰ Additional anomalies may also arise owing to the loss of compounds from chloroplasts during their isolation from aqueous systems.¹¹

This paper reports the chemical estimation of RNA and DNA in spinach chloroplasts isolated by a nonaqueous density technique. This technique yields uncontaminated plastid preparations, minimizes enzymatic degradation of the polynucleotides, and prevents the loss of polar metabolites from the chloroplast.

1. J. H. McClenden, *Am. J. Botany* 39, 275 (1952).
2. M. Holden, *Biochem. J.* 51, 433 (1952).
3. W. D. Cooper and H. S. Loring, *J. Biol. Chem.* 228, 813 (1957).
4. A. T. Jagendorf, *Plant Physiol.* 30, 138 (1955).
5. Y. Chiba and K. Sugahara, *Arch. Biochem. Biophys* 71, 367 (1957).
6. R. Spiekermann, *Protoplasma* 48, 303 (1957).
7. V. C. Littau, *Am. J. Botany* 45, 45 (1958).
8. H. Metzner, *Biol. Zentr.* 71, 257 (1952).
9. Y. Chiba, *Cytologia (Tokyo)* 16, 259 (1951).
10. S. Granick, in *The Cell*, Vol. II, Ed. Brochet & Mirsky (Academic Press, Inc., New York and London, 1961), Chapter 7.
11. H. Heber, *Ber. deut. botan. Ges.* 70, 371 (1957).

Materials and Methods

1. Chloroplast isolation

Spinach (purchased fresh from a local market) was washed thoroughly and the midribs removed. Surplus water was removed from the leaves by blotting and they were frozen in liquid nitrogen. After freezing, the leaves were placed in a desiccator precooled to -10°C , and the whole evacuated for 3 to 4 days until the leaves were dry. The temperature was gradually increased to 0°C . A flow diagram of subsequent operations carried out at 0°C is presented below.

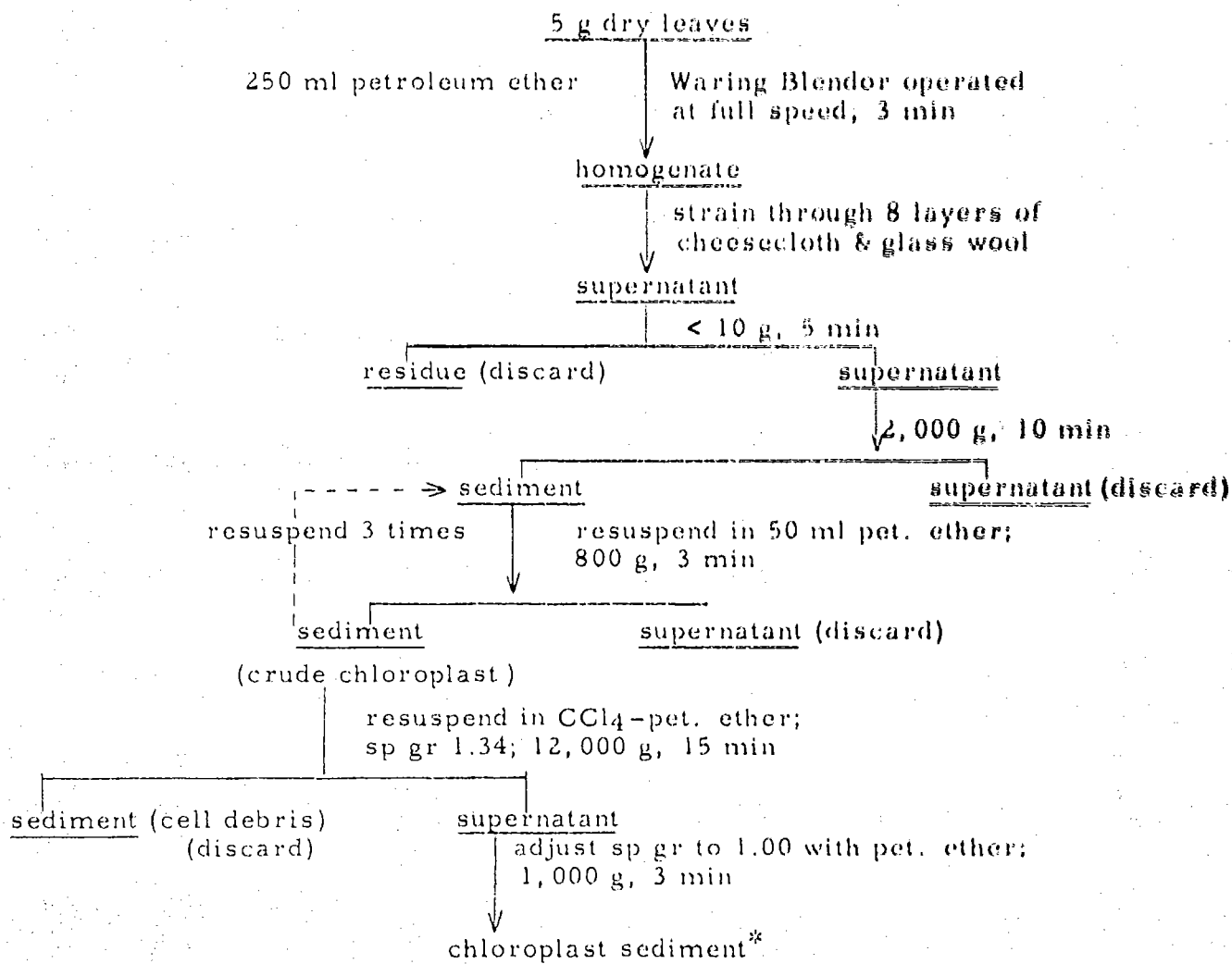

* (purity checked cytochemically by staining with methyl green)

Nonaqueous chloroplast isolation procedure;
modification of methods by Heber and Stocking (Ref 12).

2. Chemical techniques

Nucleic acids were estimated by the Smillie-Krotkov¹³ modifications of the Schmidt-Thannhauser procedures. When these modifications were used the maximum sensitivity was

0.05 mg DNA/ml by the diphenylamine reaction for deoxyribose;¹⁴

25 µg ribose/ml by the orcinol reaction;¹⁵

0.006 mg P/ml;¹⁶

0.001 mg polynucleotide per ml by ultraviolet absorption at 260 mµ.

Standard DNA (Sigma Chem. Co.) was depolymerized under identical conditions to those employed for chloroplast nucleic acids. A Cary Model R-14 recording spectrophotometer was used for all spectrophotometric measurements, using 1-cm cells.

The procedure can be summarized.

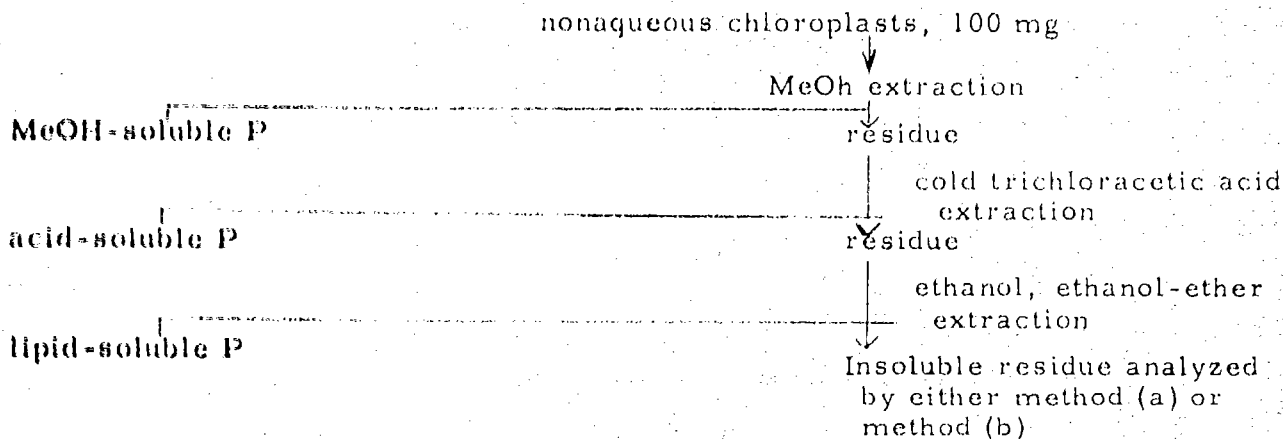

13. R. M. Smillie and G. Krotkov, *Can. J. Botany* **38**, 31 (1960).

14. K. Burton, *Biochem. J.* **62**, 315 (1956).

15. R. Markham, in *Methods of Plant Analysis*, Ed. Paech & Tracey, Vol. 4 (Springer-Verlag, Berlin, 1955), p. 246.

16. R. J. L. Allen, *Biochem. J.* **34**, 858 (1940).

(a) insoluble residue from 100 mg chloroplasts

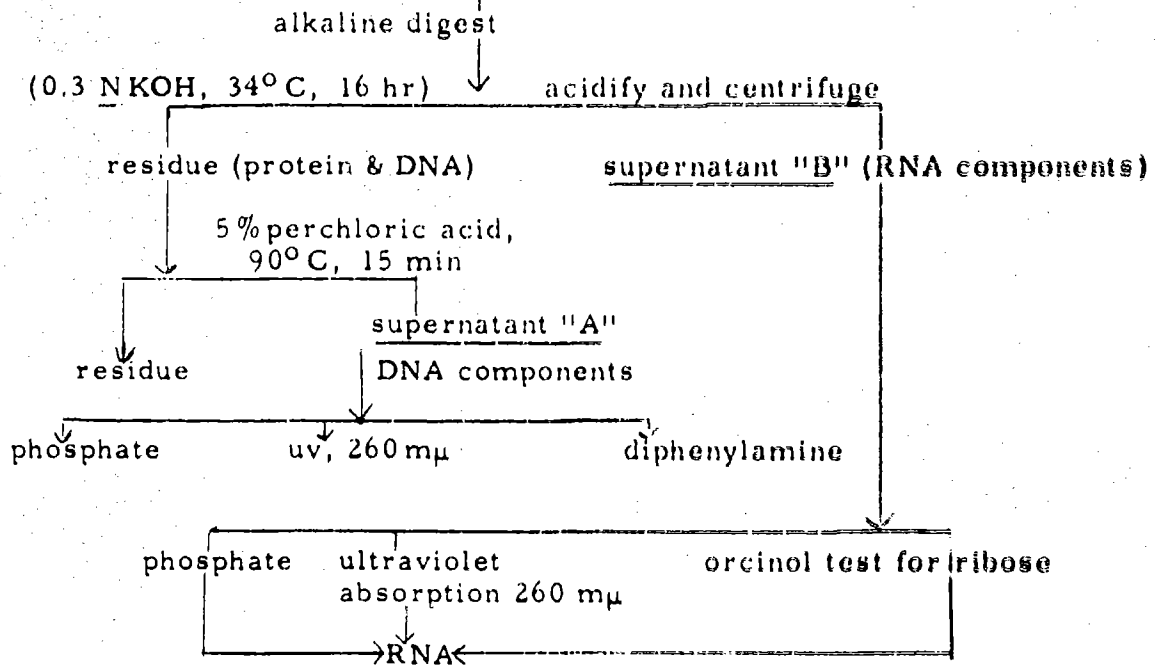

(b) insoluble residue from 100 mg chloroplasts

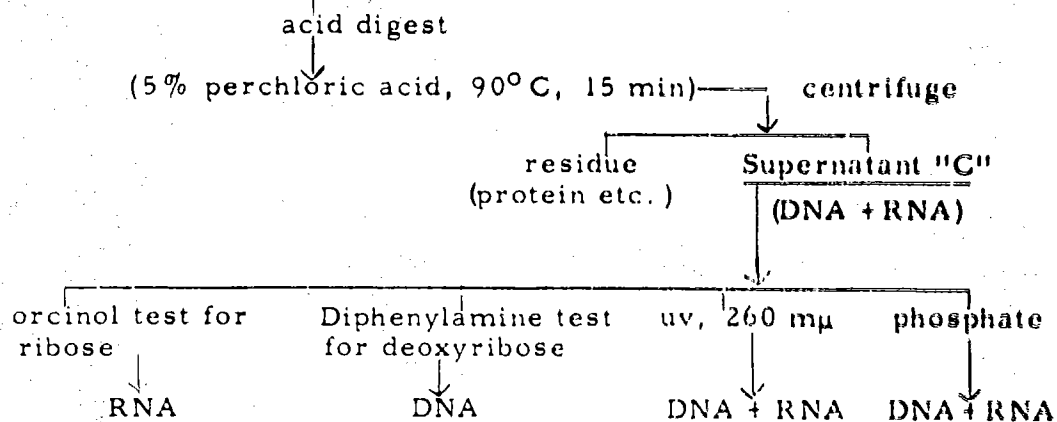

Results and Discussion

Analysis of 100 mg freeze-dried chloroplasts gave the following results.

Milligrams polynucleotide/100 mg chloroplasts, determined by various methods.

Solution	Method			
	uv, 260 mμ-- estimates bases	Diphenylamine test-- estimates deoxyribose	Orcinol test-- estimates ribose	Phosphate estimate
Supernatant A	0.795 (DNA)	0.37 (DNA)	0	0.41 (DNA)
Supernatant B	7.49 (RNA)	0	7.10 (RNA)	7.62 (RNA)
Supernatant C	7.95 (DNA + RNA)	0.1 (DNA)	7.8 (RNA)	8.1 (DNA + RNA)
C - B - A	0.56 (DNA)	--	--	0.48 (DNA)

These data show that the dry chloroplast is 0.5% DNA and 7.5% RNA by weight.

The value obtained for the RNA content of chloroplasts is considerably higher than that reported previously (2-4%),^{1, 2, 3} This is probably due to differences in the chloroplast isolation procedure employed. It is likely that RNA is leached from chloroplasts isolated from aqueous cellular homogenates, whereas this is minimized by using nonaqueous isolations.

The value obtained for the DNA content of chloroplasts is in agreement with previous reports.^{3, 5} The replication between the values obtained by analysis of deoxyribose and phosphate is good. The high value obtained from ultraviolet absorption at 260 mμ (in supernatant A) suggests interference by some hydrolysis product other than nucleotides.

Purity of the chloroplast preparations was checked by phase microscopy after staining with methylgreen. Contamination of the plastids by nuclear fragments was not detected by this method.

Summary

RNA and DNA were estimated in Spinacea oleracea chloroplasts isolated by a nonaqueous density technique.

Preparations were free of nuclear contamination, and preliminary data show that the DNA and RNA content of the dry chloroplasts is 0.5% and 7.5% (by weight), respectively.

The value we obtained for the RNA content of chloroplasts is higher than that previously reported by a factor of two, and it is likely that this result is due to our method of plastid preparation. The nonaqueous isolation technique minimized loss of RNA from the chloroplast. Thus the RNA content of these chloroplasts probably approximates the in vivo level.

5. PAPER CHROMATOGRAPHY OF NUCLEIC ACID CONSTITUENTS

Cyril Ponnampерuma

More than eighty solvent systems have been described for the separation of nucleic acid components by paper chromatography.¹ Several of these, which showed distinct advantages over the others, were investigated by us earlier.² Isobutyric acid-ammonia-EDTA³ in one dimension and butanol-propionic acid-water in the other⁴ were selected as the solvent systems for the separation of the radiation decomposition products of C¹⁴-labeled nucleotides.

In our recent work,⁵ however, we used propanol-ammonia-water⁶ in the first dimension instead of isobutyric acid-ammonia-EDTA. The propanol-ammonia-water system had several advantages over the other. Well-defined spots were obtained for all purine and pyrimidine bases, nucleosides, and nucleotides. The rate of flow of solvent was much faster. The unpleasantness of working with the evil-smelling isobutyric acid, the odor of which is evident from chromatographic papers even after the papers are dry, was eliminated.

The R_f values for the series of compounds tested with the two systems, propanol-ammonia-water and butanol-propionic acid-water, are listed in Table VI. The relative positions of the compounds in a two-dimensional chromatogram are shown in Figs. 13, 14, and 15.

The RNA bases, nucleosides, and nucleotides were obtained from the National Biochemicals Corp., Cleveland, Ohio. The deoxy compounds were supplied by Schwarz BioResearch, Inc., Mount Vernon, N. Y. The formamidopyrimidines were a gift of Dr. G. B. Brown of the Sloan-Kettering Institute for Cancer Research, New York.

The butanol-propionic acid solvent was prepared by mixing equal parts of butanol saturated with water and 60% propionic acid. The mixture was prepared immediately before use. The propanol-ammonia solvent consisted of n-propanol mixed with a solution containing 75% of 0.880 N ammonium hydroxide. Here, again, the two liquids were mixed just prior to use.

1. E. Chargaff and J. N. Davidson, Eds., The Nucleic Acids (Academic Press, Inc., New York, 1955), Vol. 1, p. 250.
2. C. Ponnampерuma, R. M. Lemmon, and F. H. Woeller; in Bio-Organic Chemistry Quarterly Report, UCRL-9408, Sept. 1960, p. 9.
3. H. A. Krebs and R. Hems, Biochim. Biophys. Acta 12, 173 (1953).
4. Murray Goodman, The Separation and Characterization of Phosphorylated Compounds from Green Plants (Ph. D. Thesis), UCRL-1961, Sept. 1952, p. 57.
5. C. Ponnampерuma, R. M. Lemmon, E. L. Bennett, and M. Calvin, Science 134, 113 (1961).
6. E. L. Bennett, Biochim. et Biophys. Acta 11, 487 (1953).

The solutions of the nucleic acid components contained 1 $\mu\text{g}/\mu\text{l}$. The xanthine and guanine, which are poorly soluble in water, were dissolved in 10% formic acid.

The chromatograms were run for 3 hr at an average temperature of 27°C. In both systems the solvent front had run approximately 50 cm from the origin.

Table VI. R_f values of purine and pyrimidine bases, nucleosides, and nucleotides in two solvent systems

Compound	Solvent system	
	Propanol-ammonia-water	Butanol-propionic acid-water
Adenine	0.64	0.79
Cytosine	0.62	0.60
Guanine	0.37	0.55
Hypoxanthine	0.55	0.58
Thymine	0.75	0.74
Uracil	0.63	0.63
Xanthine	0.41	0.50
Adenosine	0.65	0.63
Cytidine	0.60	0.46
Guanosine	0.36	0.37
Inosine	0.52	0.40
Uridine	0.54	0.47
Xanthosine	0.43	0.32
Deoxyadenosine	0.78	0.70
Deoxycytidine	0.75	0.60
Deoxyguanosine	0.59	0.50
Deoxyinosine	0.70	0.49
Deoxyuridine	0.73	0.58
Thymidine	0.76	0.73
Adenylic acid 2'	0.34	0.24
Adenylic acid 3'	0.35	0.25
Adenylic acid 5'	0.29	0.19
Cytidylic acid	0.22	0.19
Guanlylic acid	0.11	0.16
Inosinic acid	0.24	0.10
Uridylic acid	0.17	0.18
Deoxyadenylic acid	0.39	0.26
Deoxycytidylic acid	0.35	0.24
Deoxyguanlylic acid	0.22	0.17
Deoxyuridylic acid	0.35	0.17
4-Amino-5-imidazole carboxamide	0.64	0.66
4-Amino-5-formamido-6-hydroxy-pyrimidine	0.36	0.36
4, 6-Diamino-5-formamidopyrimidine	0.49	0.53
2, 4-Diamino-5-formamido-6-hydroxy-pyrimidine	0.21	0.30
2, 4, 5-Triamino-5-formamido-pyrimidine	0.22	0.37
4, 5, 6-Triaminopyrimidine sulfate	0.57	0.67

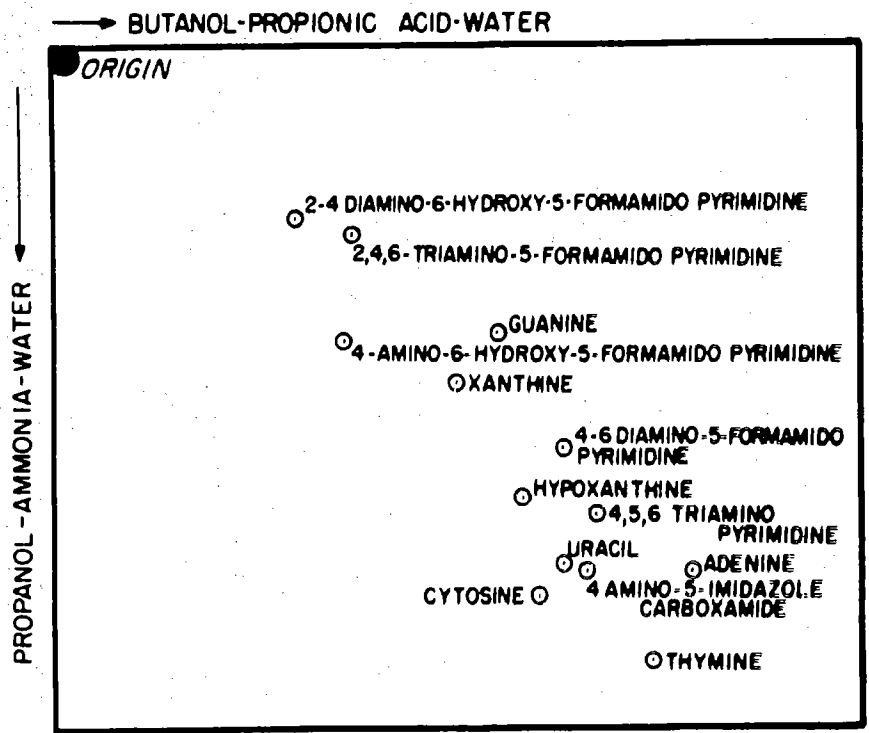

MU-2494R

Fig. 13. Two-dimensional chromatogram, purines and pyrimidines.

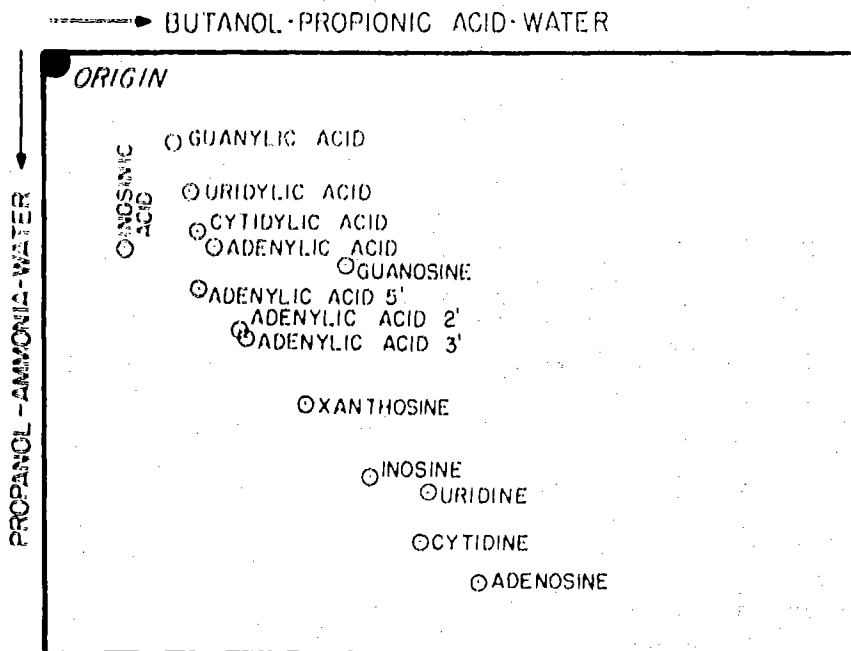

MU-24549

Fig. 14. Two-dimensional chromatogram, ribose nucleosides and nucleotides.

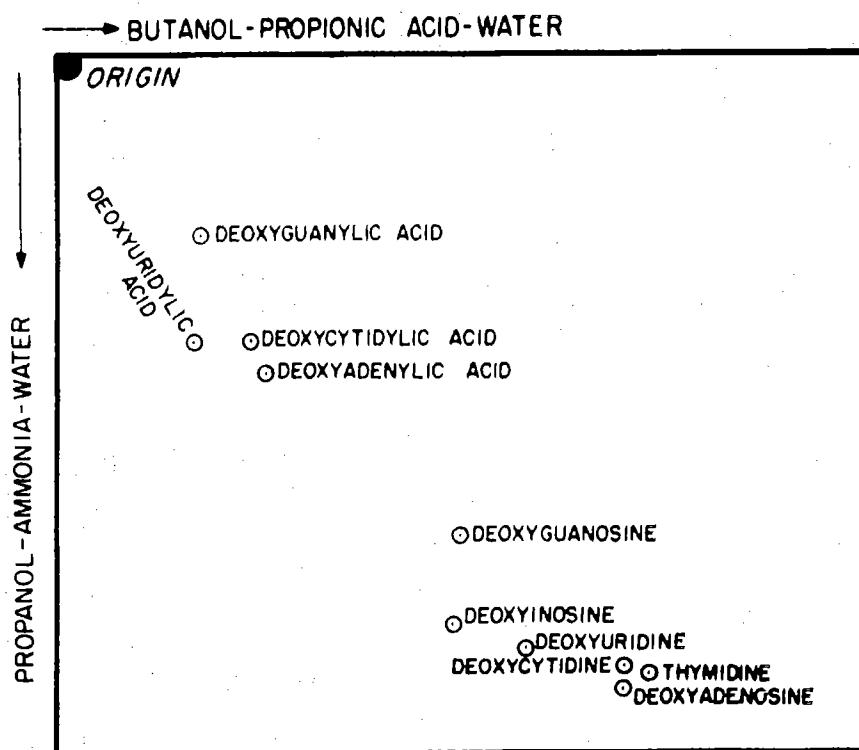

MU - 24550

Fig. 15. Two-dimensional chromatogram, deoxyribose nucleosides and nucleotides.

9. PRIMORDIAL ORGANIC CHEMISTRY: EVIDENCE FOR PRODUCTION OF
PURINES AND PYRIMIDINES FROM SIMPLE GASES
BY ELECTRON IRRADIATION

Christof Palm and Melvin Calvin

Introduction

Miller and Urey in 1953 were able to synthesize amino acids by electric discharge in a gaseous mixture of CH_4 , H_2 , and NH_3 over liquid water.¹ It was presumed that these conditions simulated the primitive terrestrial atmosphere. Since then, various workers have attempted to produce components of nucleic acids under similar or other primitive conditions.²⁻⁶ Evidence is now presented that heterocyclic bases--namely, cytosine, thymine, adenine, and 4-aminimidazole-5-carboxamide (perhaps also uracil and guanine)--can be found in an electron-irradiated mixture of CH_4 , NH_3 , H_2 , and H_2O .

During the progress of this work, two simple syntheses of bases that occur in nucleic acids have been reported. Oró heated concentrated aqueous solutions of NH_4CN for extended periods of time and found adenine and 4-aminimidazole-5-carboxamide.³ S. W. Fox heated malic acid and urea together with polyphosphoric acid and could separate uracil.⁶ This synthesis, however, using sulfuric acid as the condensing agent, has long been known.⁷

It is very suggestive that syntheses of the same kind occur upon irradiation of primitive gas mixtures over water. Indeed, the formation of both HCN and traces of urea in electric discharges has been reported.⁴ Larger amounts of urea in addition to HCN are formed in electron irradiation.⁸ Yet an extraordinarily high number of compounds and reactions compete in these mixtures, and evidence has to be provided that synthesis of complex heterocyclic bases does indeed take place in such systems.

In order to test the possibility of formation of heterocyclic bases--i. e., purines and pyrimidines as found in nucleic acids--we have chosen a

1. S. L. Miller, *J. Am. Chem. Soc.* **77**, 2351 (1955).
2. S. L. Miller, in *Intern. Union of Biochemistry Symp. Ser. Vol. 1, The Origin of Life on the Earth* (Pergamon Press, London, 1960), 126.
3. J. Oró, *Biochem. Biophys. Research Commun.*, **2**, 407 (1960).
4. J. Oró and A. P. Kimball, *Arch. Biochem. Biophys.* **94**, 217 (1961).
5. S. W. Fox, T. E. Johnson, and A. Vegotsky, *Science* **124**, 923 (1956).
6. S. W. Fox and K. Harada, *Science* **133**, 1923 (1961).
7. D. Davidson and O. Baudisch, *J. Am. Chem. Soc.* **48**, 2379 (1926).
8. C. Palm and M. Calvin, *Primordial Organic Chemistry. I. Compounds Resulting from Electron Irradiation of C^{14}H_4* , *J. Am. Chem. Soc.* (in press).

system of simple gases, CH_4 , H_2 , and NH_3 over liquid water. The energy to activate the gases was delivered by 5-Mev electrons shot into the sealed system by a linear accelerator.*

Two kinds of potentially promoting compounds were added in various experiments with this primitive system.

(a) to imitate possible mineral surface action, an iron-magnesium silicate, olivine $[(\text{MgFe})_2\text{SiO}_4]$, was added as a powder.

(b) To simulate the influence phosphorus compounds might have had in evolution, a polymer phosphate (NH_4PO_3) and phosphine (PH_3 , P_2H_6) were added.

It must be emphasized that the high dose rates necessary to achieve synthesis in reasonable times may also be highly destructive of the initially synthesized compounds. Time and energy rates alone set limits on drawing a close comparison between these experiments and chemical evolution under truly primitive conditions, either in the past history of the earth or at present in extraterrestrial environments.

Experiments and Analytical Methods

Since the general experimental and analytical methods have been described in sufficient detail elsewhere,⁸ Table VII reproduces data only on irradiated mixtures that were fully or partly examined for purines and pyrimidines.

As a rather sensitive tool, we made use of ultraviolet spectroscopy in several runs in order to search for pseudoaromatic heterocyclic bases. Except for a generally increasing absorption below 4,000 Å, no specific absorption could be seen which could have been unequivocally due to a heterocyclic system. Also, subsequent examination of more specific fractions from an ion-exchange column and simultaneously prepared paper chromatograms revealed no specific uv absorption. Since 4 to 5 mg of organic material is formed in one run, not more than 0.1% of it can be in the form of any single uv-absorbing compounds. The more sensitive tracer methods with carbon-14 were therefore explored next.

At this time, Oro and co-workers reported the formation of adenine and 4-aminoimidazole-5-carboxamide upon heating a concentrated aqueous solution of NH_4CN .³ In a preliminary attempt we found by means of paper

* The linear accelerator was maintained and operated by Mr. William Everette of the Lawrence Radiation Laboratory. We would like to express our thanks to him for his cooperation.

Table VII. Composition of irradiated gas mixtures and conversion data*†

	Experiment No.					
	M26	M28	M30	M22	M27	M31
CH ₄ pressure (cm Hg)	25.55	35.45	32.45	30.6	38	28.2
C ¹⁴ activity (mC)	0.89	2.34	4.31	1.16	2.705	4.71
H ₂ pressure (cm Hg)	4	1.9	4.15	0.2	2.2	2.
NH ₃ pressure (cm Hg)	20	20	20	20	18	20
H ₂ O (ml liquid)	20	20	18	13	18.4	
Olivine (g)	1.3	1.35				
(NH ₄ PO ₃) (mg)				100	100	
PH ₃ pressure (cm Hg)			3.4	2.8	1.03	
Temperature of H ₂ O (°C)	80	80	80	80	80	80
Time of irradiation (hr)	4	2	2	2	2	2
Total energy absorbed (ergs)	2 × 10 ¹¹	10 ¹¹	10 ¹¹	10 ¹¹	10 ¹¹	10 ¹¹
Activity in aqueous phase, after irradiation (μC)	47	27.1	49.3	33	33.5	68.5
Conversion from original C ¹⁴ H ₄ (%)	5.28	1.16	1.14	2.84	1.24	1.45

* Arranged according to the phosphine content.

† The volume of the irradiation flask was 810 ml.

chromatography of the basic fraction from run M22 that adenine and 4-aminoimidazole-5-carboxamide carried 0.03% and 0.02% respectively of the activity with them. The solvent systems used in sequence for this separation were (a) phenol-water (1470:604), (b) butanol-propionic acid-water (375:180:245), (c) repetition with butanol-propionic acid-water, and (d) propanol-ammonia-water (6:3:1). The radioautograph of the final chromatogram after 15 weeks' exposure is shown in Fig. 16.

The following method of dilution analysis was then used in an attempt to evaluate the amounts of adenine, guanine, thymine, and cytosine in runs M27 and M28. Aliquot amounts (10 ml) of these reaction mixtures were evaporated and passed through cation- and anion-exchange resins (25 cc of Dowex-50 and Dowex-1, respectively).

One hundred mg each of adenine, guanine, and cytosine were added to the cold evaporated residue of the 3 N HCl eluate from the Dowex-50 column. It was dissolved in dilute sulfuric acid, precipitated with AgNO_3 , filtered, then the filtrate made alkaline with Ba(OH)_2 , and filtered again. From the respective silver salts, the bases were extracted with HCl, then precipitated as either the free base, guanine, or the picrates of adenine and cytosine.

Cyanide and thymine were separated in a similar manner from the acid fraction. One hundred mg of thymine and 123.5 mg of KCN were used for dilution. Thymine was separated from its silver salt by H_2S .

The bases were recrystallized three times, then purified further by ion-exchange chromatography. This was done on a Dowex-50-X2 column with HCOONH_4 at pH 4, following the method of Crampton et al.⁹ The column was modified to have an i. d. of 1.5 cm and a height of 60 cm and was operated at 25°C. Five to 8 mg of each of the four bases and their respective picrates could be handled in one run.

Carbon-14 was counted after each step of the purification. The samples were counted as C^{14}O_2 after combustion, by use of liquid scintillation techniques. The specific activities that resulted after ion-exchange chromatography, as well as the respective fractions of converted CH_4 , are shown in Table VIII. Also included are the G values.

The specific activities had shown only a slight decrease between the last recrystallization and the ion-exchange purification. Therefore these values had been considered as likely. Yet it will be seen that the activities might still not be entirely due to the bases examined, and thus may be too high.

9. C. F. Crampton, A. M. Frankel, M. Benson, and A. Wade, *Analyt. Biochem.* 1, 249 (1960).

M 22
PURINES
PYRIMIDINES
(EXPOSED 107
DAYS)



g. PROPANOL - NH₂OH

4-AMINO-5-IMIDAZOL-
CARBOXAMIDE

ADENINE

ZN-2951

Fig. 16. Chromatogram of adenine and 4-aminoimidazole-5-carboxamide added to the basic fraction of M22. The dotted lines indicate the ultra-violet absorption of the carrier bases on the paper.

Table VIII. Production of CN^- , adenine, guanine, thymine, and cytosine

Experiment Number	CN^-	Adenine	Guanine	Thymine	Cytosine
M28 Specific activity (dpm/mg)	2540	104.3	12.6	13.7	123.4
Fraction of converted C^{14}H_4	2.14×10^{-2}	3.47×10^{-4}	4.19×10^{-5}	4.56×10^{-5}	4.10×10^{-4}
G	4.02×10^{-3}	1.3×10^{-5}	1.9×10^{-6}	1.7×10^{-6}	1.9×10^{-5}
M27 Specific activity (dpm/mg)	605	84.4	12.5	24.2	103.7
Fraction of converted C^{14}H_4	3.95×10^{-3}	2.19×10^{-4}	3.23×10^{-5}	6.27×10^{-5}	2.69×10^{-4}
G	8.02×10^{-4}	8.9×10^{-6}	1.3×10^{-6}	2.5×10^{-5}	1.4×10^{-5}

Calculations from the dilution analysis had indicated that the radioactivity yields should generally allow radioautography of these compounds. Two different attempts have been made in this direction:

- (a) by means of paper cochromatography alone (M26), and
- (b) by ion-exchange cochromatography combined with subsequent paper cochromatography (M27, M30, and M31).

The reaction solution of M26 containing 32.9 μC was evaporated down after 80 γ thymine, 120 γ adenine, 100 γ cytosine, and 20 γ guanine had been added. It was then spotted onto two Whatman No. 3 MM papers and chromatographed in the solvents (a) *n*-propanol-ammonia and (b) butanol-propionic acid-water. With the uv absorption as a guide, the added compounds were cut out, eluted, and run separately, each in (c) isopropanol-formic acid-H₂O (170:41:39), (d) butanol-ammonia (saturated). Again the uv-absorbing spots were eluted and now run ascending parallel on a single sheet in (e) isopropanol-HCl-H₂O (170:41:39).¹⁰ The radioautograph after 8 weeks' exposure (Fig. 17) shows carbon-14 coincidence with cytosine and adenine, and possibly with thymine. Guanine cannot be judged owing to too much streaking.

On the second attempt to achieve radioautographs of presumed purines and pyrimidines, aliquots of the whole reaction mixtures of runs M27, M30, and M31 were fractionated by ion-exchange chromatography. The procedure is the same as used for purification in the above described dilution analysis and is fully reported in the general methods of the previous paper.⁸ Two hundred γ each of thymine, cytosine, and adenine and 40 γ of guanine were initially added to 6.96 μC of M27. Cytosine and adenine (380 γ each), 500 γ of thymine, and 40 γ of guanine were added to 25.2 μC of M30. The same carriers as M30 with the addition of 400 γ of uracil and 320 γ of 4-aminoimidazole-5-carboxamide were added to 54.7 μC of M31. The evaporated and concentrated mixtures were then chromatographed on ion-exchange columns.

Figure 18 demonstrates the possibility of separating the aforementioned bases detected by their absorption at 2,600 Å. The C¹⁴ distribution of run M31 is superimposed on the same diagram.

The bases were then recovered by evaporating the respective fractions and subliming the excess ammonium formate in vacuo (0.1 MM) at 50 to 60°C (ir lamp). The residues were taken up in dilute HCl and spotted on Whatman No. 4 filter paper for two-dimensional chromatography in the solvent pair (a) propanol-ammonia-water, and (b) butanol-propionic acid-water. The chromatogram of the recovered thymine from the ion-exchange chromatographic fractionation of M31 is shown in Fig. 19 in order to indicate how complex these fractions still are, although from the diagram in Fig. 18 their separation

10. A survey of these solvent systems is given in H. Vinner, *Z. physiol. Chem.* 322, 122 (1960).

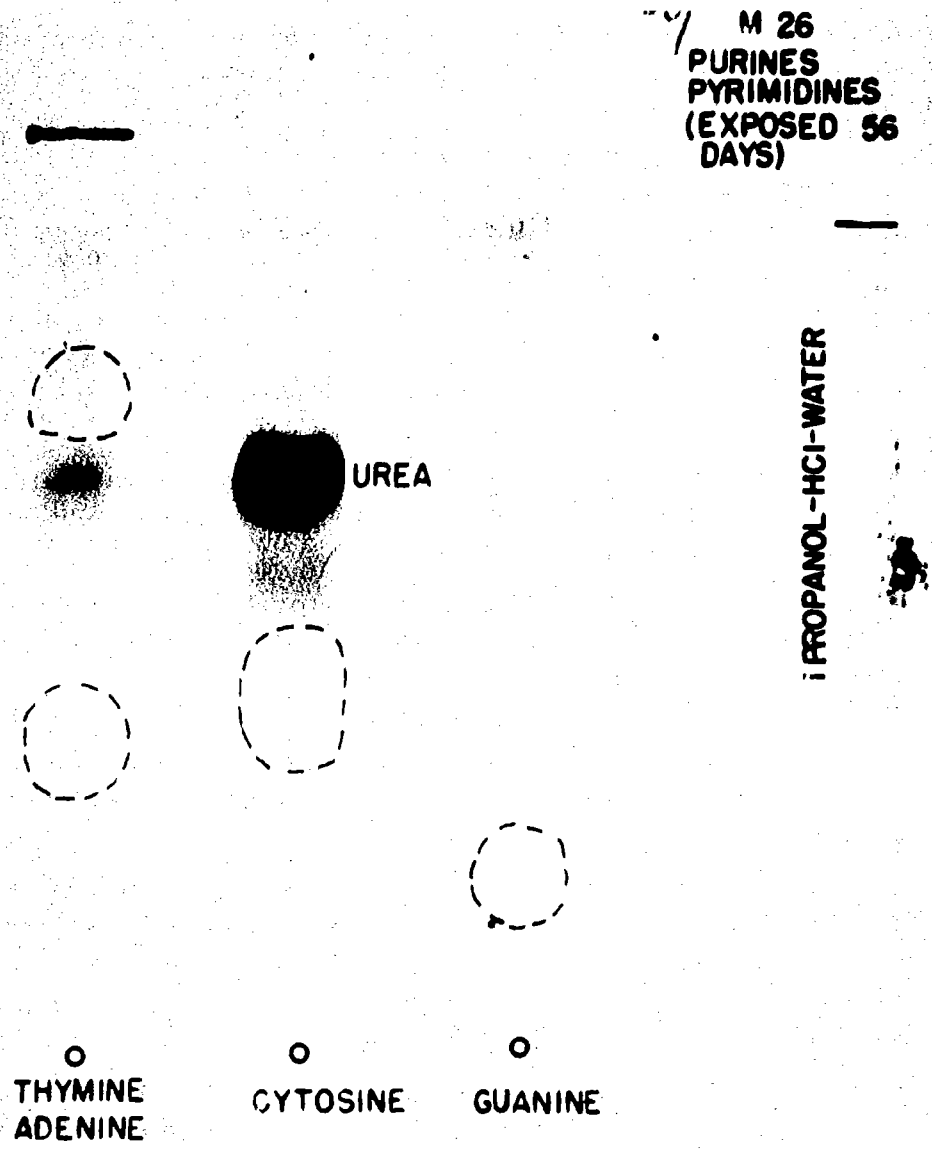

Fig. 17. Chromatogram of purines and pyrimidines in M26. The dotted lines indicate the ultraviolet absorption of the carriers on the paper.

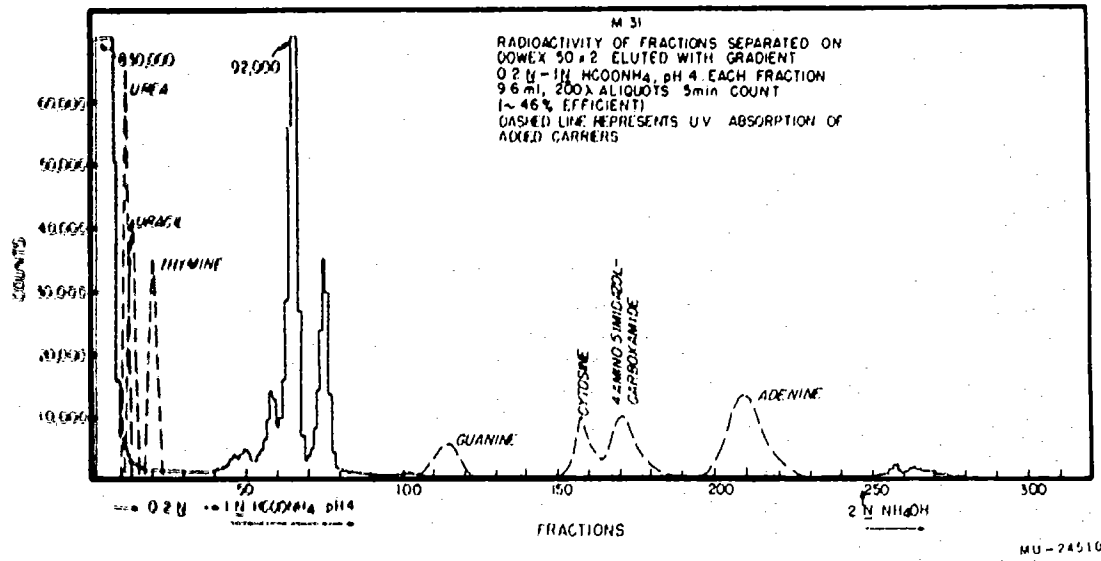

Fig. 18. Diagram of ion-exchange chromatography of M31.

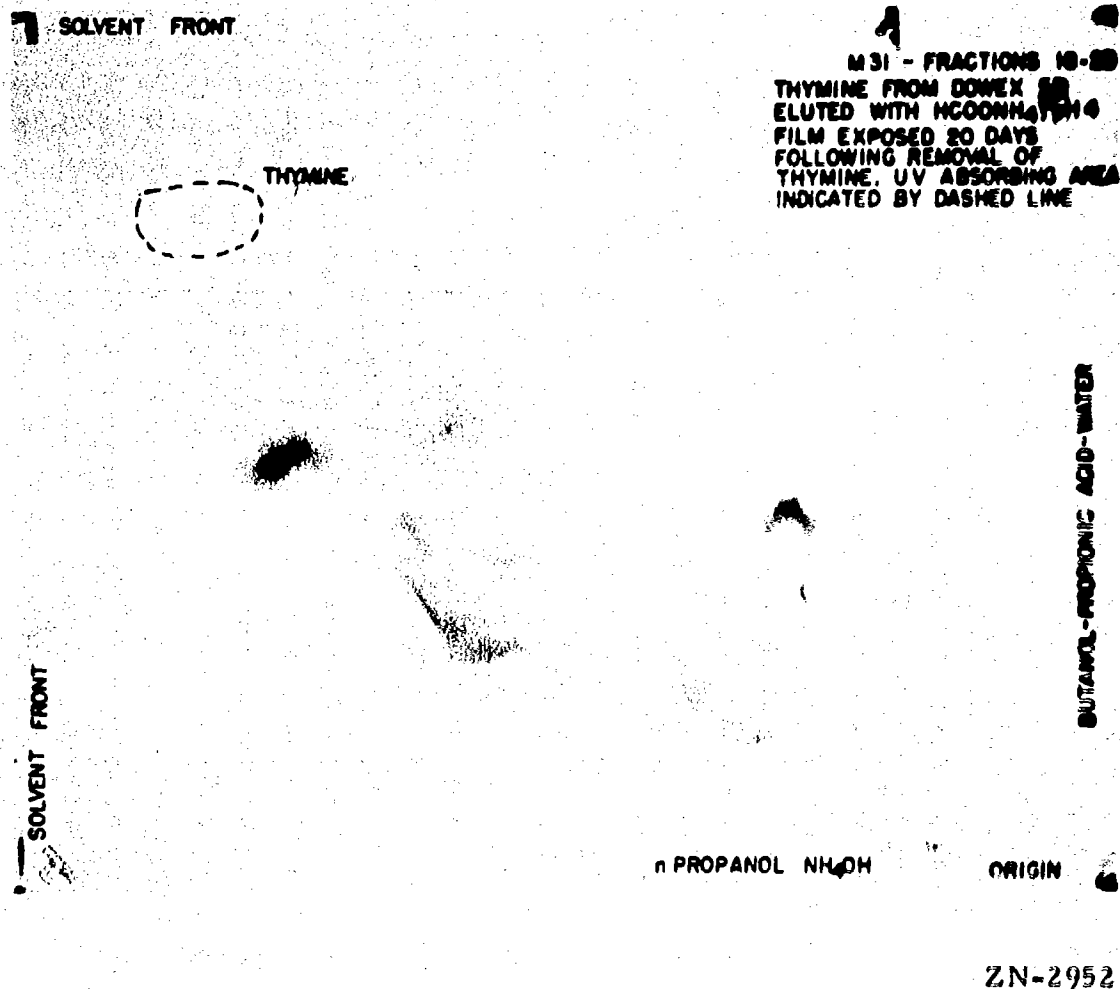

Fig. 19. M31 thymine fraction from Dowex-50 by ion-exchange cochromatography. Film exposed 20 days following removal of thymine; uv-absorbing area indicated by dotted line. This chromatogram demonstrates the complexity of the thymine fraction from ion-exchange chromatography.

appears very distinct. The uv-absorbing bases were eluted immediately from the respective paper chromatograms and spotted separately on one sheet for joint final parallel ascending chromatography with isopropanol-HCl-H₂O.

The respective radioautographs are shown in Fig. 20. Only thymine and adenine are included from run M27, as the two other bases could not be recovered owing to a mechanical failure in the fraction collector.

Thymine seems to be present in M27; adenine cannot be estimated because of streaking. In M30, thymine streaked, but adenine and cytosine seemed to coincide with small activity maxima. Guanine is negative. The final chromatogram of M31 could be exposed for radioautography for only 3 weeks. Thymine and 4-aminoimidazole-5-carboxamide appear to be present. Uracil, cytosine, adenine, and guanine cannot be seen.

The efficiency of carrying the bases through all procedures has been checked by evaluating the extinction in the ultraviolet for eluates of the spots on the final ascending chromatograms. It is generally below 50%. Thymine was 19.5% in M27. For M30, the efficiency was adenine 37%, cytosine 14.6%; thymine 30.8%, guanine 20%. For M31, it was adenine 27.1%, cytosine 7.8%, thymine 30.6%, uracil 27%, and 4-aminoimidazole-5-carboxamide 21%.

At the time of the uv measurement it was possible to determine the radioactivity in the eluates. Subsequently the formation in fractions of total converted C¹⁴ could be calculated. These values are included in Table IX. They are certainly too high for the thymine in M30 and 4-aminoimidazole-5-carboxamide in M31, since other compounds were eluted at the same time.

Results

In Table IX are summarized all the results involving added carrier bases. The question marks indicate dubious cases in which streaking of activity did not permit clear pictures. No marks appear for those cases in which no search was made.

It should be noted that the quantitative yield as estimated in Table IX is lower than that estimated in Table VIII. For this reason we refrain from quantitative estimates of possible yields in geologic time. However, it appears that the synthesis of heterocyclic bases of biological interest by these simple processes from primordial starting materials is possible, and may be included in discussions of chemical evolution.¹¹

11. M. Calvin, Chemical Evolution, Condon Lectures, Oregon State Board of Higher Education, Eugene, Oregon, 1961 (in press).

Examination of the products formed by other energy sources, such as ultraviolet radiation and electric discharge, is under way.

Table IX. Identification of products formed on the irradiation of methane-ammonia-hydrogen-water systems

Composition	Uracil	Thymine	Guanine	Cytosine	Imidazole	Adenine
<u>Experiment M26</u> CH ₄ , NH ₃ , H ₂ , H ₂ O, Olivine		+	?	+		+
<u>Experiment M30</u> CH ₄ , NH ₃ , H ₂ , H ₂ O		?	?	4.8 X 10 ⁻⁶		7.7 X 10 ⁻⁵
<u>Experiment M22</u> CH ₄ , H ₂ , NH ₃ , H ₂ O, (NH ₄ PO ₃), PH ₃					+	+
<u>Experiment M27</u> CH ₄ , H ₂ , NH ₃ , H ₂ O, NH ₄ PO ₃ , PH ₃						1.17 X 10 ⁻⁵ ?
<u>Experiment M31</u> CH ₄ , H ₂ , NH ₃ , H ₂ O, PH ₃	--	+	?	--	+	--
		7.4 X 10 ⁻⁶	1.6 X 10 ⁻⁶		9.9 X 10 ⁻⁶	

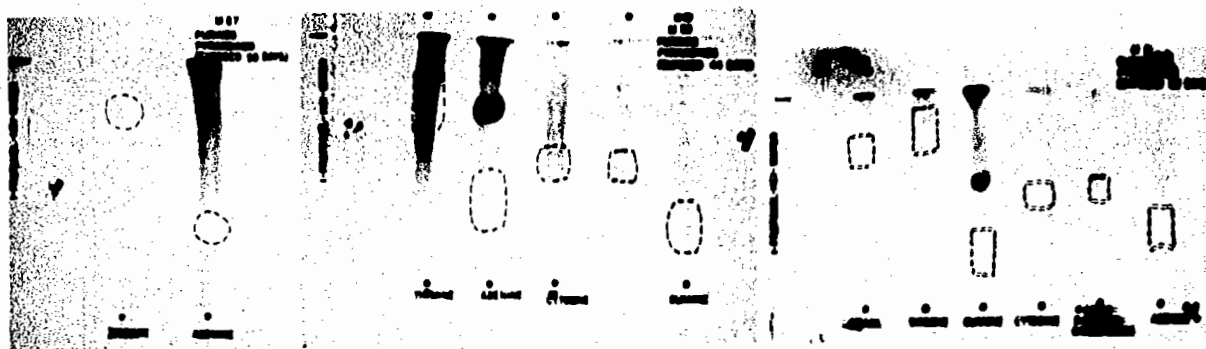

ZN-2954

Fig. 20. Radioautographs of final chromatograms of M27, M30, and M31. The dotted lines indicate added carrier.

10. ELECTRON IRRADIATION OF AQUEOUS SOLUTIONS OF HCN

Christof Palm and Melvin Calvin

In the course of electron irradiations of mixtures of simple gases (CH_4 , H_2 , NH_3) over liquid water¹ it became of interest to obtain a general idea how HCN would react under similar conditions. HCN is obtained under widely varied conditions from mixtures of CH_4 and nitrogenous gases like NH_3 or N_2 which have been subjected to electric discharge.^{2, 3} Its presence could also be confirmed during our investigations of electron irradiation of simple gases.⁴ HCN has been found in comets,⁵ and there is evidence that it is widely distributed in primitive systems.

In view of these factors and, at the same time, the high free energy of HCN, it must be considered a possible key compound in primordial chemistry, i. e., chemical evolution.

Reactions of HCN under simulated primitive terrestrial conditions have been studied by Oró.^{6, 7} These experiments have involved heating concentrated aqueous solutions of NH_4CN for extended periods of time. Amino acids and a few heterocyclic bases (adenine and 4-aminoimidazole-5-carboxamide) were identified. We have undertaken a study of the reactions of HCN and H_2O under either ultraviolet or electron irradiation to further understand its role in chemical evolution.

Experimental Procedure

In order to allow use of tracer methods, C^{14} -labeled HCN was employed in these experiments. HC^{14}N was obtained by gently reacting 1:2 H_2SO_4 with commercially obtained KC^{14}N . The irradiation flask is shown in Fig. 21. The thin-wall (0.1 mm) target cell has an extension volume to avoid overpressure on accidental heating during the irradiation. In general, the system is kept at room temperature by an air stream during the irradiations. HCN and water were condensed into the flask after it had been flushed several times with nitrogen. Before the flask was sealed for irradiation, nitrogen was allowed to bubble in until a pressure of 60 cm Hg was reached (20°C). The amounts and activities involved were 2 to 3 ml H_2O , and 1.86 μmole KC^{14}N (73 μC), which made the starting material 0.81 M in HCN.

1. C. Palm and M. Calvin, Primordial Organic Chemistry. I. Compounds Resulting from Electron Irradiation of C^{14}H_4 , J. Am. Chem. Soc. (in press).
2. S. Takahashi, Kogyokayaku Zasshi 64, 447 (1961).
3. S. L. Miller, J. Am. Chem. Soc. 77, 2351 (1955).
4. Christof Palm and Melvin Calvin, in Bio-Organic Chemistry Quarterly Report, UCRL-9519, Jan. 1961, p. 30.
5. J. Oró, Nature 190, 389 (1961).
6. J. Oró and A. P. Kimball, Arch. Biochem. Biophys. (in press).
7. J. Oró and S. Kamat, Nature 190, 442 (1961).

The target cell was then irradiated for 2 hr with 5-Mev electrons from a linear accelerator. The total dose rate absorbed was calculated to be on the order of 10^{10} ergs. After irradiation, the aqueous phase is clear, and the pH has changed from 5 to 8. It can easily be seen by Nessler reagent that NH_4^+ has been formed; this explains the alkaline pH value.

The radioactivity of aliquots of the reaction solution was determined by direct liquid scintillation counting and also, after spotting, by paper chromatography. Whereas the direct counting indicates the C^{14} activity introduced, the residual activity on the paper was taken as the converted fraction. Possible traces of NH_4CN were disregarded in this case. The converted fraction then amounts to 29% of the starting HC^{14}N .

Radioautographs of the chromatograms of the crude reaction mixture, using two solvent systems [phenol-water and butanol-propionic acid-water (designated BP), and propanol-ammonia and butanol-propionic acid-water (designated PA)] are shown in Figs. 22 and 23. Some amino acids and heterocyclic bases were added as carriers for the respective chromatography. Their final positions are indicated. Two major compounds (17.8% and 13.5%) are apparent.

Since the formation of urea was considered possible, urea was co-chromatographed with eluates from both spots. The radioactivity of the compound with higher R_f coincided in two solvents (PA and BP) with urea and is therefore taken as this base. The second major active spot is as yet unidentified. Evidence from cochromatography of several amino acids points to the formation of glycine, alanine, and aspartic acid. As yet, no further confirmation has been made.

The uv-absorbing spots from the added carrier bases were cut out and eluates from them rechromatographed for further separation in isopropanol-hydrochloric acid-water. Figure 24 represents the corresponding chromatogram. The ultraviolet absorption on the paper and the respective bases are indicated. Only with thymine and uracil does radioactivity coincide with an added carrier, yet at least most of the activity in the uracil area comes from urea in the original chromatogram. Confirmation of this identification without still further fractionation is obviously impossible. On the other hand, no negative statements can be made, since calculations that consider the starting activity on the paper and the exposure time indicate that only compounds which contained 1 part per 1,000 or more of the activity on the origin of the chromatogram would be revealed.

Discussion

A parallel experiment, heating comparable molarities and activities of aqueous HC^{14}N at 90°C for 5 days under nitrogen atmosphere, indicated no formation (less than 1 part in 10^4) of higher organic material. Also, care had been taken to avoid bacterial contamination. Therefore the radiation effect is very distinct. So far, no comparable experiment has been done by heating $\text{NH}_4\text{C}^{14}\text{N}$ under nitrogen atmosphere in order to confirm Oró's experiments.

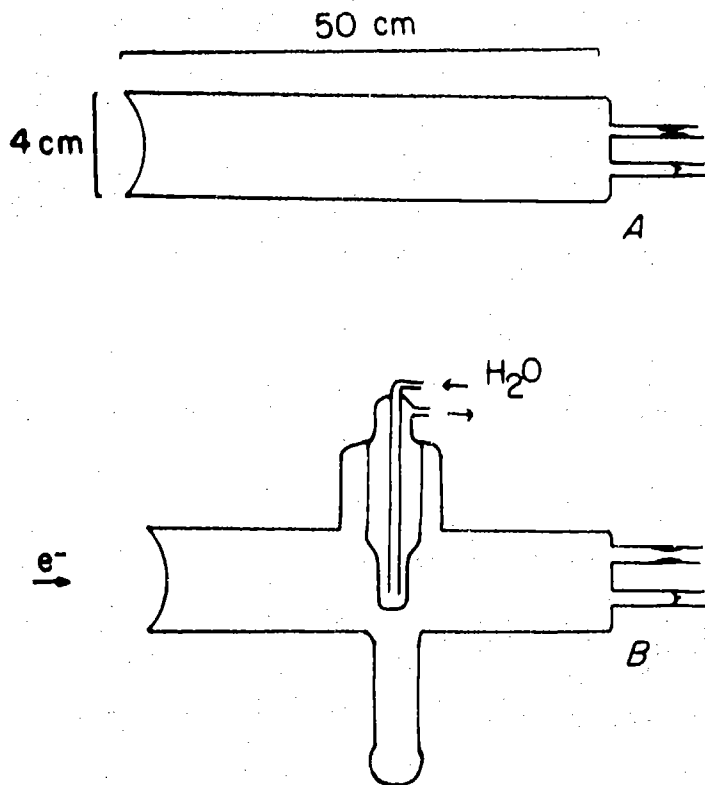

MU - 22274

Fig. 21. Irradiation flask.

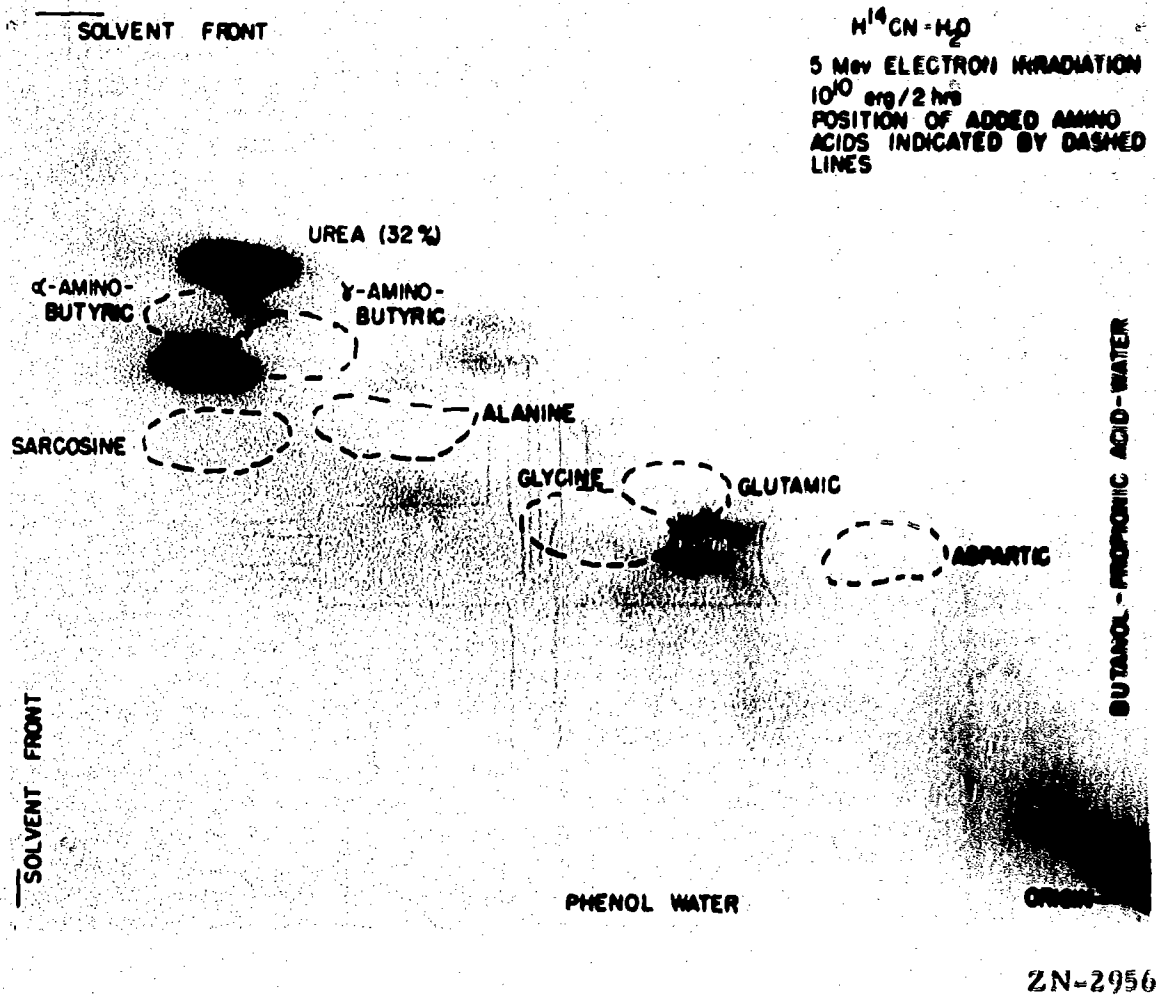

Fig. 22. Chromatogram of crude reaction mixture. Amino acids added before chromatography.

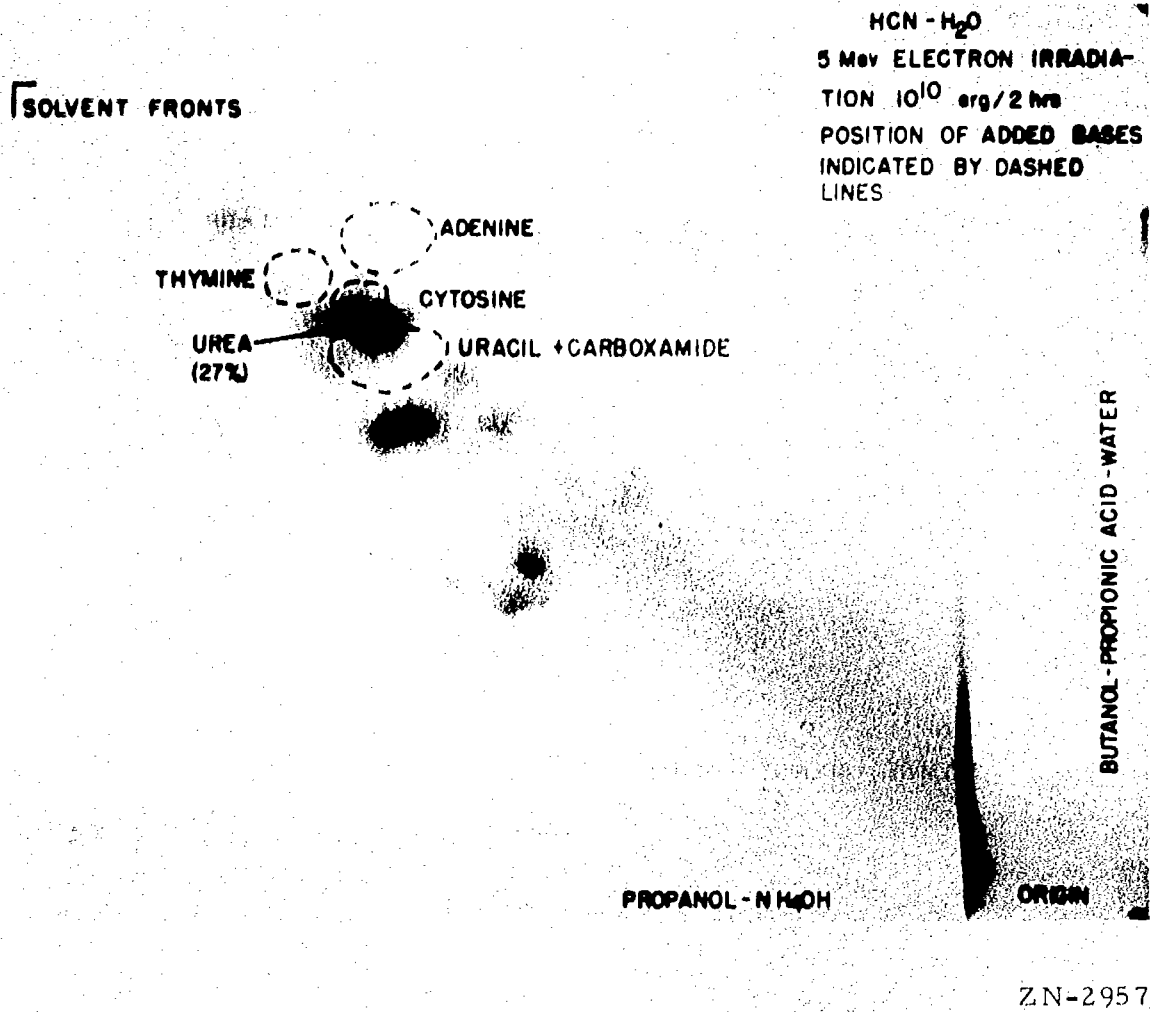
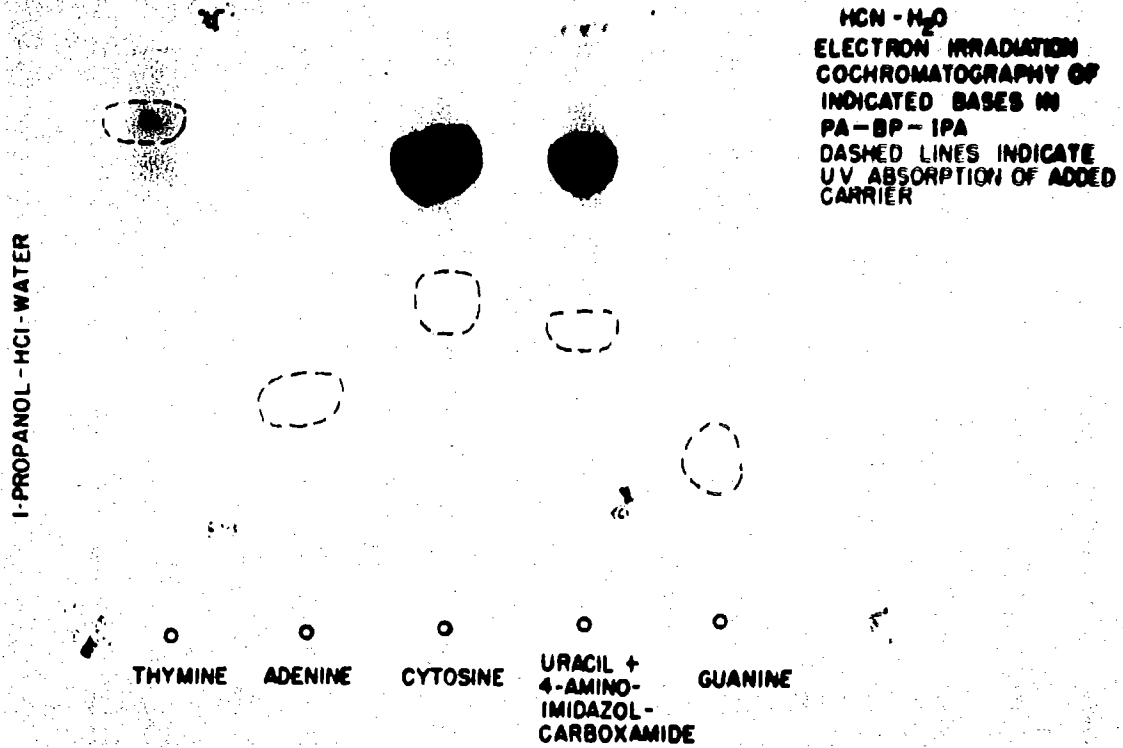

Fig. 23. Chromatogram of crude reaction mixture. Purine and pyrimidine bases added before chromatography.



ZN-2955

Fig. 24. Final ascending chromatogram of added purines and pyrimidines.

It must be kept in mind that in electron irradiation the differences between HCN and NH_4CN are very small; obviously, some NH_4^+ is formed rapidly upon bombardment.

The formation of urea in these experiments is not surprising. A reaction involving HCN and OH radicals of H_2O_2 has already been considered for its formation from CH_4 , NH_3 , and water upon electron irradiation.¹ The direct irradiation of water is well known to yield enough OH \cdot or H_2O_2 for the formation of HOCN in this experiment. Also, the formation of urea is only a repetition of Wohler's 1828 urea synthesis, since NH_4^+ was found in sufficient amounts after irradiation.

11. RADIATION CHEMISTRY OF CRYSTALLINE CHOLINE CHLORIDE

Margaret A. Smith and Richard M. Lemmon

Introduction

For some time the mechanism by which ionizing radiation decomposes crystalline choline chloride into acetaldehyde and trimethylamine has been under investigation in this Laboratory.¹ Recent work has been directed toward establishing the movement of hydrogen atoms during this decomposition by examining the products obtained from irradiation of $[(\text{CH}_3)_3\text{NCH}_2\text{CD}_2\text{OH}]^+\text{Cl}^-$ and $[(\text{CH}_3)_3\text{NCH}_2\text{CH}_2\text{OD}]^+\text{Cl}^-$. Also, attempts have been made to determine whether the decomposition is an inter- or intramolecular process by investigating the deuterium composition of the acetaldehyde obtained from the irradiation of a mixture of undeuterated and O-methylene-deuterated choline chloride. The following is a report of progress made in these investigations.

Experimental Procedures

Preparation of Deuterated Choline Chlorides

$[(\text{CH}_3)_3\text{NCH}_2\text{CD}_2\text{OH}]^+\text{Cl}^-$ was prepared, as previously described, by LiAlD_4 reduction of the ethyl ester of N, N-dimethylglycine to deuterated N, N-dimethylaminoethanol followed by quaternization with methyl iodide and subsequent conversion of the resulting deuterated choline iodide to the chloride.² The purity of the O-methylene-deuterated choline thus prepared was determined by C and H analysis and NMR spectroscopy. The NMR spectrum obtained was identical to that previously gotten for deuterated choline in which the O-methylene proton contribution was missing and the N-methylene line was sharpened by the elimination of hyperfine interactions.²

$[(\text{CH}_3)_3\text{NCH}_2\text{CH}_2\text{OD}]^+\text{Cl}^-$ was prepared by dissolving undeuterated choline chloride in a large excess of 99% D_2O . This solution was evaporated to dryness and the deuterated compound was recrystallized from N, N-dimethylformamide. Previous to using this solvent for recrystallization, it was established by NMR spectroscopy that the hydrogen atom of the solvent would not exchange with D_2O . The purity of the hydroxyl-deuterated choline was determined by C and H analysis. It was not possible to obtain a check of the purity by NMR spectroscopy, since no suitable solvent for this purpose could be found.

Purification of Evolved Acetaldehyde and Trimethylamine

Initially the acetaldehyde from irradiated choline chloride samples was isolated by dissolving the sample in 0.1 N H_2SO_4 , refluxing this solution, and sweeping the evolved acetaldehyde into a cold trap with a helium stream.

1. Margaret A. Smith and Richard M. Lemmon, in Bio-Organic Chemistry Quarterly Report, UCRL-9208, June 1960, p. 27.
2. Robert O. Lindblom, Electron-Spin-Resonance and Chemical Studies of Radiation Damage of Choline Chloride and some of its Analogs (Thesis), UCRL-8910, October 19, 1959, pp. 31-34.

The acetaldehyde was then transferred into an evacuated flask and its mass spectrum taken. However, it was found that when acetaldehyde is vaporized from an acidic D_2O solution its subsequent mass spectrum shows that considerable deuterium is exchanged into the molecule. Consequently this method of isolating acetaldehyde was abandoned. It was then decided to attempt to separate acetaldehyde from trimethylamine and any other radiation-decomposition products by vapor-phase chromatography (VPC). A 10-foot dimethylsulfolane column was found to be suitable in pilot experiments using mixtures of reagent acetaldehyde and trimethylamine and material from irradiated undeuterated choline chloride. The experimental procedure and chromatographic results are described below.

The irradiated choline chloride sample is cooled to -119° in an ethyl bromide slush, opened, quickly attached to an evacuated line, and the volatile products vacuum-distilled into a trap suitable for introducing the sample into the vapor-phase chromatograph. The sample is then processed on dimethylsulfolane at room temperature, with helium as a carrier gas at a flow rate of 50 to 90 cc/min. A VPC trace typical of those obtained for both deuterated and undeuterated choline samples is reproduced in Fig. 25. As may be seen, the acetaldehyde is cleanly separated from several minor products (the nature of which is discussed in detail later). It was first thought that one of these small components seen in the VPC trace was trimethylamine, but further investigation revealed that the amine is produced in the radiation decomposition as the hydrochloride salt, and not even a trace appears in the acetaldehyde fraction. Consequently the trimethylamine is obtained by adding strong NaOH solution to the irradiated choline chloride sample from which the acetaldehyde fraction has been removed. The evolved amine is then swept with helium or nitrogen into a cold trap and processed on dimethylsulfolane under the same conditions as used for acetaldehyde. A typical trimethylamine VPC trace is reproduced in Fig. 26. As is seen, no other products except a trace of acetaldehyde have been detected in this fraction.

Mass Spectra of Trimethylamine and Acetaldehyde from Deuterated Choline

By use of the above procedure pure trimethylamine samples from irradiated O-methylene-deuterated, hydroxyl-deuterated, and undeuterated choline chloride have been obtained and their mass spectra compared with the spectrum given for trimethylamine in the American Petroleum Institute Catalog of Mass Spectral Data. The results are presented in Table X.

These results demonstrate that no deuterium is present in trimethylamine obtained from either O-methylene- or hydroxyl-deuterated choline chloride.

The mass spectral data for acetaldehyde are presented in Table XI. Unfortunately, the results are much less certain than those obtained for trimethylamine. Furthermore, interpretation of these results is made somewhat more difficult by variations in the general experimental procedures and conditions described above.

In the first experiments with acetaldehyde samples from undeuterated and O-methylene-deuterated choline chlorides, methane was used as a carrier gas for the vapor-phase chromatography. Since it was difficult to get a stable

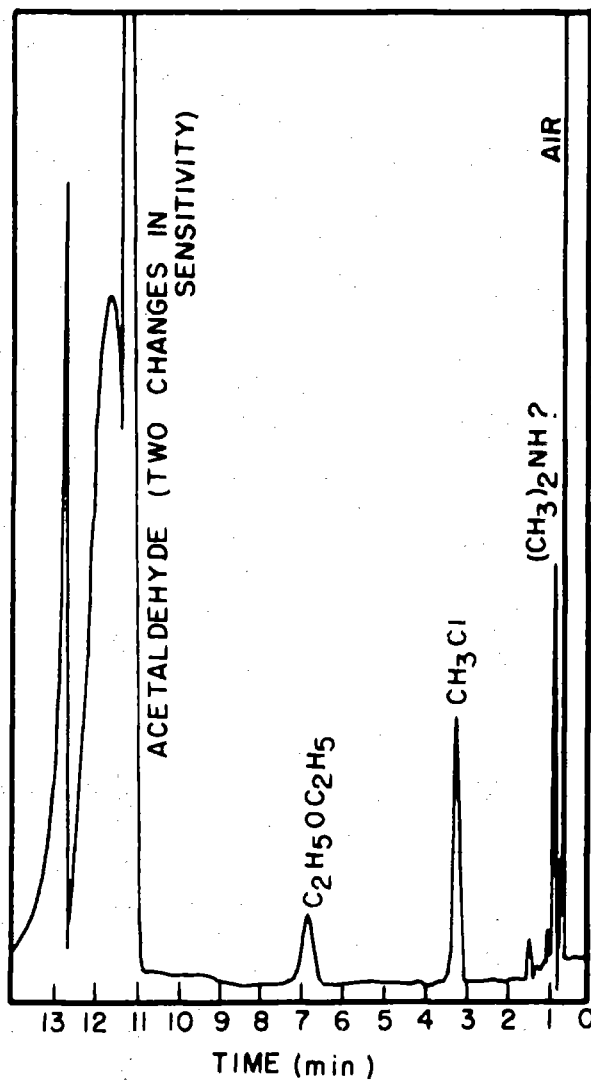

MU-24560

Fig. 25. Mass trace from chromatography of acetaldehyde fraction on dimethylsulfolane. Carrier gas: He, flow rate: 90 cc/min; T = 21°.

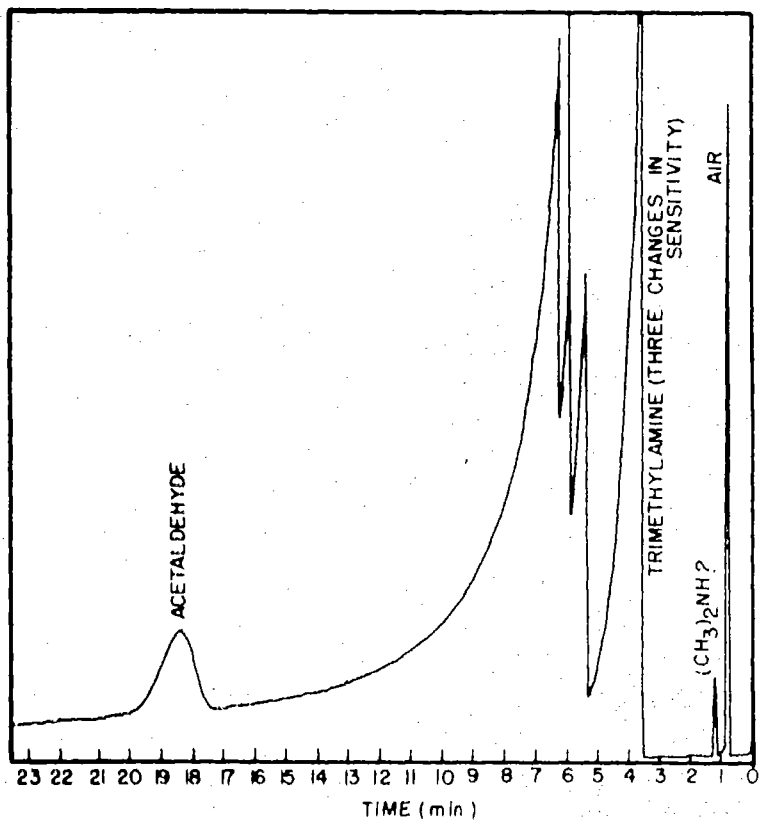

Fig. 26. Mass trace from chromatography of trimethylamine fraction on dimethylsulfolane. Carrier gas: He; flow rate: 60 cc/min; T = 20°.

Table X. Mass spectral data for trimethylamine.

Source of (CH ₃) ₃ N	m/e	Relative intensity at 68 v	Relative intensity at 70 v
[(CH ₃) ₃ NCH ₂ CD ₂ OH] ⁺ Cl ⁻	58	100.00	
	59	47.73	
	60	1.87	
[(CH ₃) ₃ NCH ₂ CH ₂ OD] ⁺ Cl ⁻	58	100.00	
	59	45.74	
	60	1.34	
[(CH ₃) ₃ NCH ₂ CH ₂ OH] ⁺ Cl ⁻	58	100.00	
	59	46.55	
	60	1.52	
Data from API catalog	58		100.00
	59		38.70
	60		1.31

base line on the VPC with methane, helium was used as the carrier gas in the next set of experiments. This change produced no pronounced variation in the mass spectral results. The acetaldehyde from undeuterated choline chloride had in both cases (3a and 3b shown in Table XI) a mass spectrum quite comparable to that given in the Catalog of Mass Spectral Data (1) and to that obtained for reagent acetaldehyde in this Laboratory (2). The acetaldehyde from O-methylene-deuterated choline chloride in both cases (4a and 4b) gave major mass peaks at 46 and 30, clearly indicating a structure of CH₂DCDO.

At this time, it was decided to confirm this result for acetaldehyde from O-methylene-deuterated choline chloride by NMR spectroscopy. For this purpose, a relatively large amount of acetaldehyde is required. Consequently, a large-scale synthesis of the O-methylene-deuterated choline chloride was run. After acceptable results had been obtained from C and H analysis and NMR spectroscopy, the material was irradiated and the decomposition products processed by VPC with helium as a carrier gas. The bulk of the acetaldehyde gotten was mixed with an approximately equal amount of benzene, and the NMR spectrum of this mixture was taken. The remaining acetaldehyde was mixed with CO₂, in order to confirm the mass assignments made previously, and the mass spectrum of this mixture taken (4b'). This

Table VI. Mass spectral data for selected 20-sec. irradiated samples.

m/e	1. Data from API at 75°	2. Percent of total ion at 75°	3. Acetamide from N ₂ O ₂ CH ₃ CO ₂ CH ₃	4. Acetamide from N ₂ O ₂ CH ₃ CO ₂ CH ₃	5. Acetamide from N ₂ O ₂ CH ₃ CO ₂ CH ₃
29	100.00	100.00	100.00	100.00	100.00
30	1.14	1.14	1.14	1.14	1.14
43	20.70	20.70	20.70	20.70	20.70
44	45.70	45.70	45.70	45.70	45.70
45	1.24	1.24	1.24	1.24	1.24
46	0.10	0.10	0.10	0.10	0.10

- a. CH₄ carrier gas used, VPC line contaminated
- b. He carrier gas used, VPC line contaminated
- c. He carrier gas used, VPC line not contaminated
1. First O-methylene-deuterated choline chloride preparation
2. Second O-methylene-deuterated choline chloride preparation; sample mixed with CO₂ in container previous mass assignments
3. Second O-methylene-deuterated choline chloride preparation recovered from earlier irradiation
4. Third O-methylene-deuterated choline chloride preparation

Table VI. Mass spectral data for a series of deuterated chloroethane derivatives. (continued)

m/e	1. Data from API catalog Ref. 76	2. Reagent grade Acetate Ref. 76	3. Acetate from $(CH_3)_2NCH_2CH_2OH$ Ref. 76		4. Acetate from $(CH_3)_2NCH_2CD_2OH$ Ref. 76		5. Acetate from $(CH_3)_2NCH_2CD_2CD_2OH$ Ref. 76
			a	b	a	b	
29	100.00	100.00	100.00	100.00	100.00	100.00	100.00
30	1.14	1.15	1.15	1.15	1.15	1.15	1.15
43	26.70	30.55	30.66	30.66	30.66	30.66	30.66
44	45.70	38.35	38.11	38.11	38.11	38.11	38.11
45	1.24	1.80	1.82	1.82	1.82	1.82	1.82
46	0.10	0.12	0.13	0.13	0.13	0.13	0.13

- a. CH_4 carrier gas used; CPC line contaminated
- b. He carrier gas used; CPC line contaminated
- c. He carrier gas used; CPC line box contaminated
- 1. First O-methylene-deuterated choline chloride preparation
- 2. Second O-methylene-deuterated choline chloride preparation; sample mixed with EO₂ to confirm previous mass assignments
- 3. Second O-methylene-deuterated choline chloride preparation recovered from ether irradiation
- 4. Third O-methylene-deuterated choline chloride preparation

mass spectrum showed major peaks from acetaldehyde at masses 45 and 30 with some enhancement of mass 46, indicating a mixture of CH_3CDO and CH_2DCDO . The NMR spectrum, rather than the single peak expected from CH_2DCDO , consisted of a doublet, one peak of which was approximately three times the size of the other.

Two factors were suspected to have been responsible for these discordant results. Perhaps the synthesis had failed to yield choline chloride completely deuterated in the O-methylene position, although the elemental and NMR analysis indicated complete deuteration, or the products had been contaminated during the chromatography. The irradiated sample was recovered, purified by several recrystallizations, and another C and H analysis and NMR spectrum obtained. These having again indicated complete deuteration in the O-methylene position, the VPC was checked for contamination. Material giving a large number of mass peaks ranging from mass 20 to mass 60 was found when the helium stream from the VPC was run through a trap cooled in liquid nitrogen. The source of this contamination was eventually found to be impurities from the methane used as a carrier gas, which had been absorbed on the Tygon tubing connecting the chromatograph with the tanks of carrier gases. Consequently, a separate line used only for helium was installed. When we used this line and a new dimethylsulfolane column, we found that the effluent helium stream was essentially free of material condensable at liquid nitrogen temperature.

The contamination having been removed, acetaldehyde samples from undeuterated choline chloride and a small portion of the recovered O-methylene-deuterated choline chloride were processed. The sample from the undeuterated material gave a mass spectrum comparable to all the results previously obtained (3c). However, the acetaldehyde from the O-methylene-deuterated material again gave a spectrum showing major peaks at masses 45 and 30 with some enhancement of mass 46 (4c). This disagreement with the earlier results for O-methylene-deuterated choline chloride could not, however, be attributed to the VPC contamination of the acetaldehyde obtained in the previous experiments since, as indicated above, acetaldehyde from undeuterated choline chloride gave the same spectrum whether processed through the contaminated or clean system.

Therefore, despite the excellent C and H and NMR data obtained for the material from the second synthesis, it was decided to prepare a third batch of O-methylene-deuterated choline chloride. Again, satisfactory elemental and NMR analyses were obtained. The acetaldehyde from radiation decomposition again gave major peaks at masses 45 and 30 with some enhancement of mass 46 (4c).

Attempts are currently being made to resolve these conflicting results by more directly determining the amount of deuterium in the methyl group of the acetaldehyde. As reported by Blacet and Heldman, this methyl group may be isolated as methyl iodide from the photolysis of acetaldehyde in the presence of iodine.³ The methyl iodide can then be examined mass spectrometrically for the presence of deuterium. Several preliminary experiments with reagent acetaldehyde have been made. Difficulties have been encountered

3. F. E. Blacet and J. D. Heldman, J. Am. Chem. Soc. 64, 889 (1942).

in isolating mass spectrometrically pure methyl iodide from the reaction mixture. Side products which cochromatograph with the methyl iodide on both silicone and dimethylsulfolane columns have been observed. It is hoped that these contaminants can be removed by chromatography on Apiezon. If so, an acetaldehyde sample from O-methylene-deuterated choline chloride will be photolyzed and the mass spectrum of the methyl iodide examined.

Only one mass spectrum for acetaldehyde from irradiated $\{(\text{CH}_3)_3\text{NCH}_2\text{CH}_2\text{OD}\}^+\text{Cl}^-$ has been taken (5). This spectrum has an enhanced mass-45 peak and may be tentatively said to corroborate that set of results which indicates that O-methylene-deuterated choline chloride yields on radiation decomposition a mixture of CH_3CDO and CH_2DCDO . However, no firm conclusions about hydroxyl-deuterated choline can be drawn until more data have been obtained.

Equimolar mixtures of $\{(\text{CH}_3)_3\text{NCH}_2\text{CH}_2\text{OH}\}^+\text{Cl}^-$ and $\{(\text{CH}_3)_3\text{NCH}_2\text{CD}_2\text{OH}\}^+\text{Cl}^-$ have been irradiated and the mass spectra of the acetaldehyde samples produced taken in order to ascertain whether the decomposition is an inter- or intramolecular process. However, no interpretation of these spectra can be made until the mass spectrometric results from the pure O-methylene-deuterated material are certain.

Minor Radiation Decomposition Products from Choline Chloride

As was seen in Fig. 25 above, a few minor products were detected when acetaldehyde samples from the radiation decomposition of both deuterated and undeuterated choline chlorides were chromatographed on dimethylsulfolane. That material which, at a flow rate of 90 cc/min, comes off the column within the first 2 min has been trapped and rechromatographed on dimethylsulfolane at a much slower flow rate. The component peaks have been trapped individually and their mass spectra taken. Only one component appeared consistently, and it has been tentatively identified as dimethylamine. The peak that appears about 3 min after injection in Fig. 25 has been definitely identified as methyl chloride. The peak appearing 7 min after injection was found to be ethyl ether. However, choline chloride is usually recrystallized from an alcohol-ether mixture. Since this peak was not seen when the choline chloride had been recrystallized from N,N-dimethylformamide, it is very likely that it results from ether occluded in the crystals. Whether this is indeed occluded ether will be determined by examining for radioactivity the ether peak from a sample of choline chloride labeled with carbon-14 in the O-methylene position. Trimethylamine and acetaldehyde, however, remain the only major products of the radiation decomposition of choline chloride. Methyl chloride, the only other product definitely identified, appears in amounts representing not more than 1% of the acetaldehyde produced.

12. THE RADIATION DECOMPOSITION OF GUANINE

Cyril Ponnampereuma and Richard M. Lemmon

In a previous report we described the action of ionizing radiation on guanine-2-C¹⁴ and guanine-8-C¹⁴.¹ The more ready formation of volatile C¹⁴ products from guanine-8-C¹⁴ indicates the greater sensitivity of the imidazole ring of the purine system to destruction by irradiation.

Further experiments have been performed to learn what types of products are formed when guanine-2-C¹⁴ is irradiated at a dose level of 10⁶ to 10⁷ rads. As with adenine,² two general types of effects were observed. In one instance the purine ring is preserved. In the other, either the imidazole ring or the pyrimidine ring undergoes fission.

Guanine-2-C¹⁴ sulfate, with a specific activity of 9.2 µC/mg, was obtained from the Southern Research Institute, Birmingham, Alabama. A 0.02% solution was used for the irradiation. The methods of irradiation, paper chromatography, and radioautography were the same as those described in our earlier work.³

One hundred microliters of guanine-2-C¹⁴ solution irradiated at 2 × 10⁶ rads was cochromatographed in two dimensions with 25 µg of each of the following nonradioactive compounds: adenine, hypoxanthine, xanthine, uracil, 4-amino-5-imidazole carboxamide, 4,6-diamino-5-formamidopyrimidine, 4-amino-6-hydroxy-5-formamidopyrimidine, 2,4,6-diamino-5-formamidopyrimidine, and 2,4-diamino-6-hydroxy-5-formamidopyrimidine. The unlabeled materials were detected by means of their uv absorption. Darkening of the x-ray film corresponding to the uv-absorbing areas was found for the first seven compounds listed.

As uracil and 4-amino-5-imidazole carboxamide have R_f values very close to each other in both the solvent systems used, these two compounds could not be distinguished from each other.

Cochromatography in at least two other solvent systems will be necessary before we can be certain that the seven compounds listed above are formed when an aqueous solution of guanine is irradiated.

1. Cyril Ponnampereuma and Richard M. Lemmon, in *Bio-Organic Chemistry Quarterly Report UCRL-9772*, June 1961, p 70.
2. Cyril Ponnampereuma and Richard M. Lemmon, in *Bio-Organic Chemistry Quarterly Report, UCRL-9652*, April 1961, p. 50.
3. C. Ponnampereuma, R. M. Lemmon, E. L. Bennett, and M. Calvin, *Science* 134, 113 (1961).

13. FORMAMIDO PYRIMIDINES FROM ADENINE

Cyril Ponnamperuma and Richard M. Lemmon

Among the effects of ionizing radiation on aqueous solutions of adenine is the opening of the imidazole ring to give rise to formamidopyrimidines.^{1,2} Hems observed the formation of 4-amino-5-formamido riboside when aqueous guanylic acid was irradiated.³ In our study of the γ -ray decomposition of aqueous solutions of adenine we have identified the 4-amino-6-hydroxy-5-formamidopyrimidine and the 4,6-diamino-5-formamidopyrimidine.²

The 4-amino-6-hydroxy-5-formamido compound was produced in very small yield, about 0.5% being formed (from 0.1% adenine solutions) at 2×10^6 rads. The compound probably arises from hypoxanthine that is formed during the irradiation. The 4,6-diamino-5-formamidopyrimidine was produced in greater yield, about 10% conversion taking place at the same dose level.

Figure 27 is a two-dimensional chromatogram of adenine-2-C¹⁴ irradiated at 2×10^6 rads. Compound A has been identified as the 4,6-diamino-5-formamido compound. This is presumably formed by the fission of the C-8-to-N-9 bond in adenine. If the ring opening took place by the fission of the N-7-to-C-8 bond, the 5,6-diamino-4-formamido compound might also be formed.¹

Although several methods are available for the preparation of 4,6-diamino-5-formamidopyrimidine,^{4,5,6} the 5,6-diamino-4-formamido compound has, to our knowledge, not been reported in the literature. Any attempt at formylation of 4,5,6-triaminopyrimidine has resulted in the formation of the 5-formamido compound.

To find out whether Compound B was an isomer of A, three lines of approach were open to us: (a) synthesis of the 4-formamido compound for cochromatography with B; (b) cyclization of B to see whether it gives adenine; and (c) hydrolysis of B to 4,5,6-triaminopyrimidine (a commercially available compound).

Formylation of the 4,5,6-triaminopyrimidine after protection of the position 5 by a reagent such as the carbobenzoxy group should give us the 4-formamido compound. But any attempt at removal of the protecting group would also result in the loss of the labile -CHO group. The approach through synthesis does not seem very hopeful.

1. Cyril Ponnamperuma and Richard M. Lemmon, in Bio-Organic Chemistry Quarterly Report, UCRL-9652, April 1961, p. 50.
2. Cyril Ponnamperuma and Richard M. Lemmon, in Bio-Organic Chemistry Quarterly Report, UCRL-9772, June 1961, p. 70.
3. G. Hems, *Nature* 181, 1721 (1958).
4. L. F. Cavalieri and A. Bendich, *J. Am. Chem. Soc.* 72, 2593 (1950).
5. L. F. Cavalieri and A. Bendich, *J. Am. Chem. Soc.* 71, 533 (1949).
6. V. M. Cook and H. M. Kalckar, *J. Chem. Soc.* 1950, 1030.

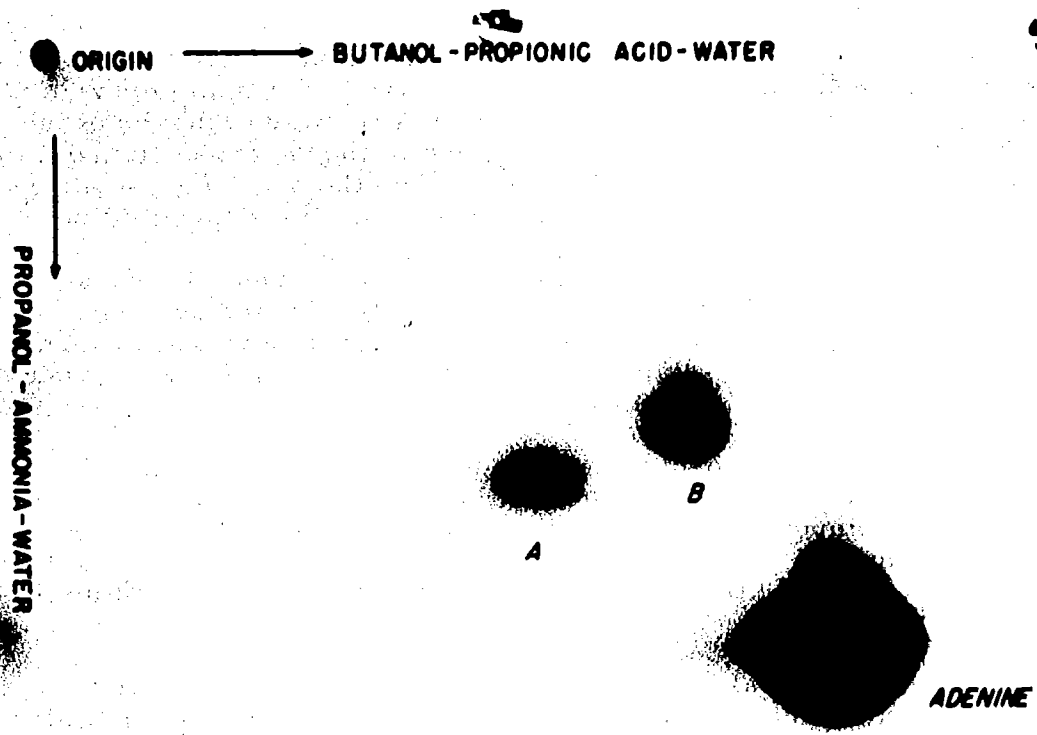

ZN-2953

Fig. 27. Paper chromatogram of products from irradiation of adenine-2-C¹⁴.
Compound A: 4,5-diamino-5-formamidopyrimidine;
Compound B: 5,6-diamino-4-formamidopyrimidine (tentative identification).

4, 5, 6-diamino-5-formamidopyrimidine cyclizes readily to adenine.^{6, 7} If compound B were the isomer of A it should also cyclize back to adenine. In one experiment the spots A + B, from a chromatogram of adenine-2-C¹⁴ irradiated at 2×10^6 rads, were eluted with water. The eluates were evaporated to dryness in vacuo and were each dissolved in 0.5 ml of formamide. The solutions were heated in sealed tubes for 2.5 hr at 170°C. The chromatography of the products indicated that about 40% of A was converted to adenine. In B about 10% conversion took place. In both A and B none of the original material was found at the end of the reaction. From B several other products were formed during the cyclization. However, both A and B do yield adenine upon heating.

In a second experiment, 0.1 mg of unlabeled 4, 6-diamino-5-formamidopyrimidine⁶ was hydrolyzed with 250 λ of 1 N HCl at 100 to 110° for 1 hour. The product had the same R_f values as 4, 5, 6-triaminopyrimidine. Compounds A and B eluted from a chromatogram of adenine-2-C¹⁴ irradiated at 2×10^6 rads were hydrolyzed under similar conditions. The product analysis indicated that A yielded about 50% 4, 5, 6-triaminopyrimidine. From B, however, a uv-absorbing material was formed which did not have the R_f values corresponding to 4, 5, 6-triaminopyrimidine.

The result of the cyclization experiment would appear to indicate that B was 5, 6-diamino-4-formamidopyrimidine, while the result of the hydrolysis experiment remains inconclusive. Further investigation of this problem is under way.

7. L. F. Cavalieri and G. B. Brown, J. Am. Chem. Soc. 71, 533 (1949).

14. COMPLEXES OF SULFUR ACIDS WITH ELECTRON ACCEPTORS

P. R. Hammond

Continuing the work described in a previous report,¹ a number of sulfur acids were investigated with electron acceptors in the presence of bases. Color reactions were again observed and they are recorded in Table XII. Abbreviations are the same as listed in the previous report, and a new abbreviation, Tr, indicates transient coloration (duration a few seconds).

1. P. R. Hammond, in Bio-Organic Chemistry Quarterly Report, UCRL-9772, June 1961, p. 48.

Table XII. Colors of sulfur acids with electron acceptors and base.

Sulfur acid	1	2	3	4	5	6	7	8	9
C + TEA dioxan	R-Br*	Tr-R-Br*	Tr-Br*	R	R	R	D-Br*	D-Br	R-Br
B + TEA dioxan	Br*	Tr-Br*	Tr-Br*	R	R	R-Br	Br*	Br	P
TCE + Py ethanol	R-Br	Tr-R-Br	Tr-R-Br	-	-	Y	Y	-	-
TNB + TEA ethanol	D-R*	D-R*	D-R*	D-R*	D-R*	-	0	-	0-Br
TNM + Py ethanol	0	R-0	R-0	L-0	-	-	-	-	-

Compounds used are (1) n-dodecyl mercaptan, (2) m-toluenethiol, (3) α -benzenethiol, (4) α -mercaptoacetanilide, (5) α -mercapto-N-2-naphthylacetamide, (6) 2-mercaptobenzoxazole, (7) 2-mercaptobenzothiazole, (8) 2-mercapto-6-nitrobenzothiazole, (9) 2-mercapto-4-phenylthiazole.

15. THE DIETHYL PHOSPHONATE-TRINITROBENZENE COMPLEX

P. R. Hammond

This complex, described in a previous report,¹ was studied in absolute alcohol in the presence of tertiary bases. The spectrum obtained was independent of the base although the rate of color production varied with the strength of the base in water. The growth of the 559-m μ peak is a close approximation to the relation

$$\frac{dD}{dt} = k_1 + C \exp(-k_2 t),$$

where the constants k_1 , k_2 , and C together with literature values for the base dissociation constants in water are shown in Table XIII.

Table XIII. Reaction of diethyl phosphonate ($10^{-2}M$) and trinitrobenzene ($10^{-2}M$) catalyzed by bases ($10^{-2}M$) at 27°C.

Run	$10^2 k_1$ (min ⁻¹)	$10^2 k_2$ (min ⁻¹)	$10^2 C$ (min ⁻¹)	$10^5 K_B$
1	27	130	85	64
2	13	60	38	67
3	1.5	11	12	7.4
4	1.5	9.4	4.1	1.0
5	0.49	10	1.9	26

The bases used are 1—triethylamine, 2—tri-n-butylamine, 3—trimethylamine, 4—dimethylbenzylamine, 5—triisobutylamine.

1. P. R. Hammond, in Bio-Organic Chemistry Quarterly Report, UCRL-9772, June 1961, p. 33.

This report was prepared as an account of Government sponsored work. Neither the United States, nor the Commission, nor any person acting on behalf of the Commission:

- A. Makes any warranty or representation, expressed or implied, with respect to the accuracy, completeness, or usefulness of the information contained in this report, or that the use of any information, apparatus, method, or process disclosed in this report may not infringe privately owned rights; or
- B. Assumes any liabilities with respect to the use of, or for damages resulting from the use of any information, apparatus, method, or process disclosed in this report.

As used in the above, "person acting on behalf of the Commission" includes any employee or contractor of the Commission, or employee of such contractor, to the extent that such employee or contractor of the Commission, or employee of such contractor prepares, disseminates, or provides access to, any information pursuant to his employment or contract with the Commission, or his employment with such contractor.